



America's Finest City

THE CITY OF SAN DIEGO



Assessment Engineer's Report

BLACK MOUNTAIN RANCH NORTH MAINTENANCE ASSESSMENT DISTRICT

Annual Update for Fiscal Year 2017

under the provisions of the

**San Diego Maintenance Assessment District Procedural Ordinance
of the San Diego Municipal Code**

Prepared For

City of San Diego, California

Prepared By

EFS Engineering, Inc.

P.O. Box 22370

San Diego, CA 92192-2370

(858) 752-3490

June 2016

CITY OF SAN DIEGO

Mayor

Kevin Faulconer

City Council Members

Sherri Lightner
District 1 (Council President)

Lorie Zapf
District 2

Todd Gloria
District 3

Myrtle Cole
District 4

Mark Kersey
District 5

Chris Cate
District 6

Scott Sherman
District 7

David Alvarez
District 8

Marti Emerald
District 9 (Council President Pro Tem)

City Attorney

Jan Goldsmith

Chief Operating Officer

Scott Chadwick

City Clerk

Elizabeth Maland

Independent Budget Analyst

Andrea Tevlin

City Engineer

James Nagelvoort

Assessment Engineer

EFS Engineering, Inc.

Table of Contents

Assessment Engineer’s Report
Black Mountain Ranch North Maintenance Assessment District

Preamble1
Executive Summary2
Background3
District Proceedings for Fiscal Year 20173
 Bond Declaration3
District Boundary3
Project Description4
Separation of General and Special Benefits4
 City Standard5
 External Benefits5
Cost Estimate6
 Estimated Costs6
 Annual Cost-Indexing6
Method of Apportionment7
 Estimated Benefit of Improvements7
 Camino Del Sur & Paseo Del Sur7
 Other Collector & Neighborhood Streets8
 Apportionment Methodology8
 Equivalent Benefit Units (EBUs)8
 Land Use Factor8
 Unit Assessment Rates10
 Sample Calculations11
Summary Results13

EXHIBITS

- Exhibit A: Boundary Map
- Exhibit B: Estimated Annual Expense, Revenues & Reserves
- Exhibit C: Assessment Roll

Assessment Engineer's Report Black Mountain Ranch North Maintenance Assessment District

Preamble

Pursuant to the provisions of the "San Diego Maintenance Assessment District Procedural Ordinance" (being Division 2, Article 5, Chapter VI of the San Diego Municipal Code), applicable provisions of "Proposition 218" (being Article XIID of the California Constitution), and provisions of the "Proposition 218 Omnibus Implementation Act" (being California Senate Bill 919) (the aforementioned provisions are hereinafter referred to collectively as "Assessment Law"), and in accordance with the Resolution of Intention, being Resolution No. _____, adopted by the CITY COUNCIL OF THE CITY OF SAN DIEGO, COUNTY OF SAN DIEGO, STATE OF CALIFORNIA, in connection with the proceedings for the BLACK MOUNTAIN RANCH NORTH MAINTENANCE ASSESSMENT DISTRICT (hereinafter referred to as "District"), EFS ENGINEERING, INC., as Assessment Engineer to the City of San Diego for these proceedings, submits herewith this report for the District as required by Assessment Law.

PRELIMINARY APPROVAL BY THE CITY COUNCIL OF THE CITY OF SAN DIEGO, COUNTY OF SAN DIEGO, CALIFORNIA, ON THE _____ DAY OF _____, 2016.

Elizabeth Maland, CITY CLERK
CITY OF SAN DIEGO
STATE OF CALIFORNIA

FINAL APPROVAL BY THE CITY COUNCIL OF THE CITY OF SAN DIEGO, COUNTY OF SAN DIEGO, CALIFORNIA, ON THE _____ DAY OF _____, 2016.

Elizabeth Maland, CITY CLERK
CITY OF SAN DIEGO
STATE OF CALIFORNIA

Executive Summary

Project: Black Mountain Ranch North
Maintenance Assessment District

Apportionment Method: Equivalent Benefit Unit (EBU)

	FY 2016	FY 2017 ⁽¹⁾	Maximum ⁽²⁾ Authorized
Total Parcels Assessed:	2,195	2,389	--
Total Estimated Assessment:	\$0.00	\$0.00	--
Total Number of EBUs:	5,749.73	5,102.21	--
<i>Zone A</i>	1,583.04	594.27	--
<i>Zone B</i>	12.00	12.00	--
<i>Zone C</i>	58.00	58.00	--
<i>Zone D</i>	618.83	618.83	--
<i>Zone E</i>	575.24	575.24	--
<i>Zone F</i>	1,360.59	1,811.44	--
<i>Zone G</i>	635.32	644.43	--
<i>Zone H</i>	906.71	788.00	--
Assessment per EBU:			
<i>Zone A</i>	\$0.00	\$0.00	\$17.16 ⁽³⁾
<i>Zone B</i>	\$0.00	\$0.00	\$276.91 ⁽³⁾
<i>Zone C</i>	\$0.00	\$0.00	\$45.25 ⁽³⁾
<i>Zone D</i>	\$0.00	\$0.00	\$213.48 ⁽³⁾
<i>Zone E</i>	\$0.00	\$0.00	\$163.05 ⁽³⁾
<i>Zone F</i>	\$0.00	\$0.00	\$47.75 ⁽³⁾
<i>Zone G</i>	\$0.00	\$0.00	\$57.13 ⁽³⁾
<i>Zone H</i>	\$0.00	\$0.00	\$33.82 ⁽³⁾

⁽¹⁾ FY 2017 is the City's Fiscal Year 2017, which begins July 1, 2016 and ends June 30, 2017. Total Parcels Assessed, Total Estimated Assessment, and Total Number of EBUs may vary from prior fiscal year values due to parcel changes and/or land use re-classifications.

⁽²⁾ Maximum authorized annual amounts subject to cost-indexing provisions as set forth in this Assessment Engineer's Report.

⁽³⁾ Prior fiscal year's maximum authorized annual assessment increased by cost-indexing factor of 5.45.

Annual Cost-Indexing:

The maximum authorized assessment rate has been increased based on the approved annual cost-indexing provisions.

Bonds:

No bonds will be issued in connection with this District.

Background

Black Mountain Ranch – “Subarea 1” of the City of San Diego (City) North City Future Urbanizing Area – is located east of Fairbanks Ranch and north of Torrey Highlands. The purpose of the Black Mountain Ranch North Maintenance Assessment District (District) is to fund annual maintenance of identified lighting improvements within the northern portion of Subarea 1. The City retained Boyle Engineering Corporation to prepare an Assessment Engineer’s Report for Fiscal Year 2007 and beyond. The Assessment Engineer’s Report was approved and assessments confirmed in Fiscal Year 2007.

District Proceedings for Fiscal Year 2017

This District is authorized and administered under the provisions of the “San Diego Maintenance Assessment District Procedural Ordinance” (being Division 2, Article 5, Chapter VI of the San Diego Municipal Code), applicable provisions of “Proposition 218” (being Article XIII D of the California Constitution), and provisions of the “Proposition 218 Omnibus Implementation Act” (being California Senate Bill 919) (the aforementioned provisions are hereinafter referred to collectively as “Assessment Law”). This report has been prepared in compliance with Assessment Law.

The purpose of the proposed proceedings and this Assessment Engineer’s Report is to update the District budget and assessments for Fiscal Year 2017, and authorize the continued levy of assessments for the life of the District. The Fiscal Year 2017 assessments proposed within this Assessment Engineer’s Report are equal to or less than the maximum authorized assessment. Therefore, the vote requirements of Section 4 of Article XIII D do not apply to these proceedings.

A public hearing will be scheduled where public testimony will be heard by the Council, and the Council may, at its discretion, adopt a resolution ordering the levy of assessments for the life of the District, and collection of the Fiscal Year 2017 proposed assessments.

Bond Declaration

No bonds will be issued in connection with this District.

District Boundary

The boundary of the District generally coincides with the northern portion of Black Mountain Ranch, areas which receive direct and immediate access from the improvement corridors. For benefit apportionment purposes, the District has been divided into eight zones

(denoted as “A,” “B,” “C,” “D,” “E,” “F,” “G” and “H”) as shown in **Exhibit A**.

The Boundary Map and Assessment Diagram for the District are on file in the Maintenance Assessment Districts section of the Park and Recreation Department of the City of San Diego, and by reference are made a part of this report. The Boundary Map and Assessment Diagram for the District are available for public inspection during normal business hours. A reduced copy of the Boundary Map is included as **Exhibit A**.

Project Description

The proposed assessments will be used to fund defined improvements and activities within the District. The activities include maintenance and servicing of identified street lighting improvements (i.e., decorative acorn style and cobra style fixtures). The District improvements are generally located as shown in **Figure 1**. For additional detail as to location and type of improvements, please refer to the engineering plans and specifications on file with the City Park and Recreation Department. The improvements include, but are not limited to, the following: poles, fixtures, bulbs, conduits, and other appurtenant facilities required to provide such lighting service. Activities include, but are not limited to, the furnishing services and materials necessary for the ordinary and usual operation, preservation, repair, and rehabilitation of the District improvements.

The proposed assessments may be used to construct and/or maintain additional improvements of like character and nature within the District to the extent that such improvements are consistent with the current apportionment methodology.

The engineering drawings for the improvements to be maintained by the District are on file at Map and Records in the Development Services Department. The improvements and services provided by the District will be maintained in accordance with specifications and contracts on file with the Park and Recreation Department. These documents are available for public inspection during normal business hours.

Separation of General and Special Benefits

The identified improvements and activities provide benefits to the parcels located within the District. Some of these benefits are “special benefits,” benefits that are above and beyond the City’s standard level of service, and exclusive of those “general benefits” provided to the public at large or properties located outside the District. Under

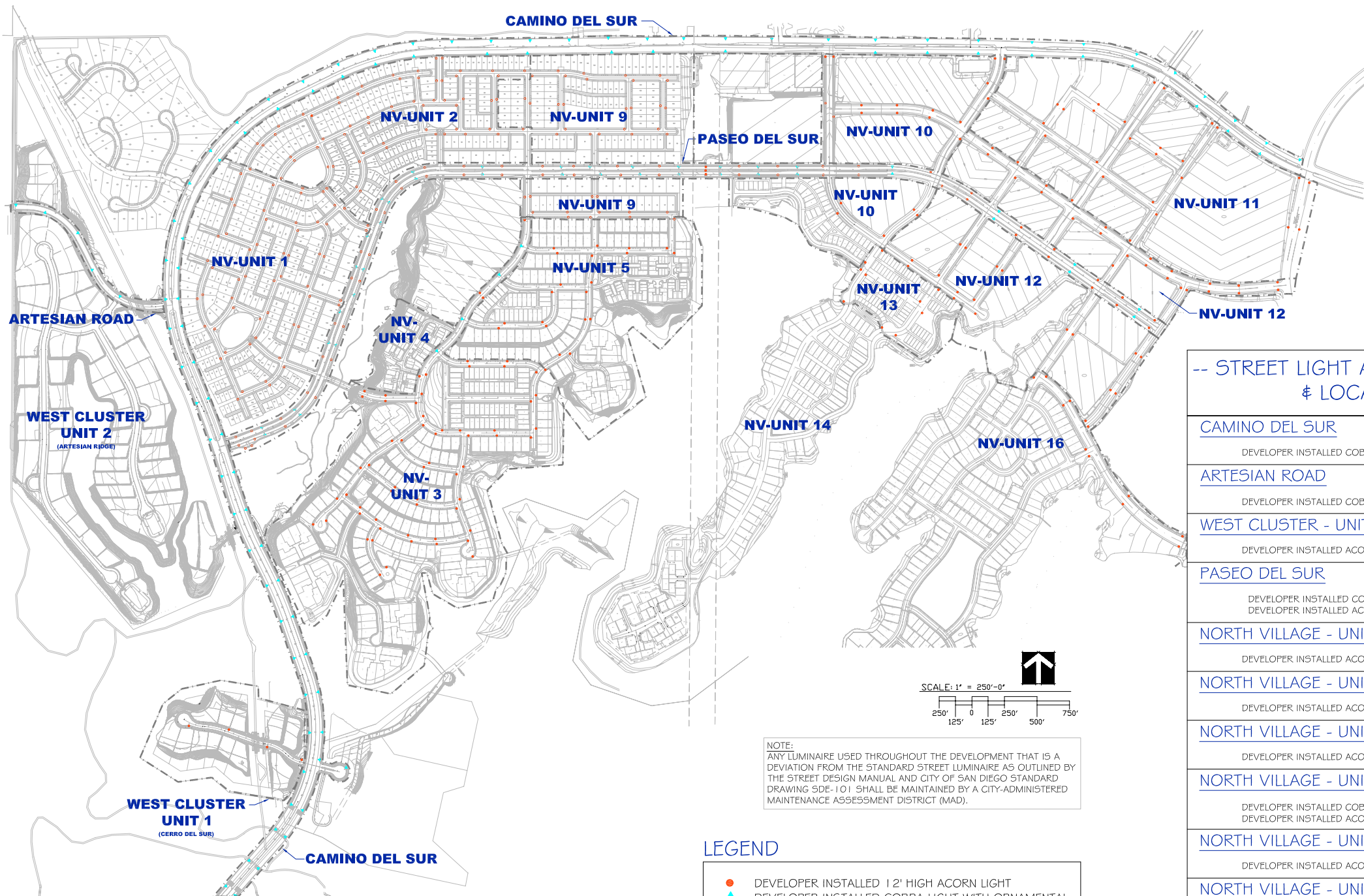

NOTE:
 ANY LUMINAIRE USED THROUGHOUT THE DEVELOPMENT THAT IS A DEVIATION FROM THE STANDARD STREET LUMINAIRE AS OUTLINED BY THE STREET DESIGN MANUAL AND CITY OF SAN DIEGO STANDARD DRAWING SDE-101 SHALL BE MAINTAINED BY A CITY-ADMINISTERED MAINTENANCE ASSESSMENT DISTRICT (MAD).

LEGEND

- DEVELOPER INSTALLED 12' HIGH ACORN LIGHT
- ▲ DEVELOPER INSTALLED COBRA LIGHT WITH ORNAMENTAL BASE

-- STREET LIGHT ANALYSIS BY STYLE & LOCATION --

CAMINO DEL SUR	(TM-40-0529)
DEVELOPER INSTALLED COBRA LIGHTS = 91	
ARTESIAN ROAD	
DEVELOPER INSTALLED COBRA LIGHTS = 5	
WEST CLUSTER - UNIT 1 - (CERRO DEL SUR)	TM-40-0529
DEVELOPER INSTALLED ACORN LIGHTS = 4	
PASEO DEL SUR	(TM-40-0528)
DEVELOPER INSTALLED COBRA LIGHTS = 40 DEVELOPER INSTALLED ACORN LIGHTS = 61	
NORTH VILLAGE - UNIT 1	(TM-40-0528)
DEVELOPER INSTALLED ACORN LIGHTS = 57	
NORTH VILLAGE - UNIT 2	(TM-40-0528)
DEVELOPER INSTALLED ACORN LIGHTS = 58	
NORTH VILLAGE - UNIT 9	(TM-40-0528)
DEVELOPER INSTALLED ACORN LIGHTS = 37	
NORTH VILLAGE - UNIT 3	(TM-40-0528)
DEVELOPER INSTALLED COBRA LIGHTS = 4 DEVELOPER INSTALLED ACORN LIGHTS = 62	
NORTH VILLAGE - UNIT 5	(TM-40-0528)
DEVELOPER INSTALLED ACORN LIGHTS = 21	
NORTH VILLAGE - UNIT 10	(TM-40-0528)
DEVELOPER INSTALLED ACORN LIGHTS = 19	
NORTH VILLAGE - UNIT 11	(TM-40-0528)
DEVELOPER INSTALLED ACORN LIGHTS = 27	
NORTH VILLAGE - UNIT 12	(TM-40-0528)
DEVELOPER INSTALLED ACORN LIGHTS = 41	
NORTH VILLAGE - UNIT 13	(TM-40-0528)
DEVELOPER INSTALLED ACORN LIGHTS = 12	
NORTH VILLAGE - UNIT 16	(TM-40-0528)
DEVELOPER INSTALLED ACORN LIGHTS = 10	

LIGHTING DETAILS AND AESTHETICS



DEL SUR - STREET LIGHTS & SIGNAGE

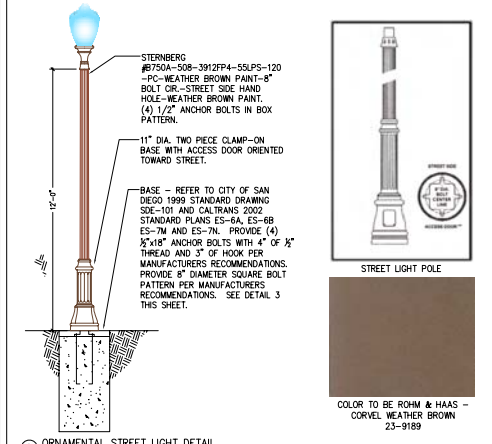

1 ORNAMENTAL STREET LIGHT DETAIL NOT TO SCALE

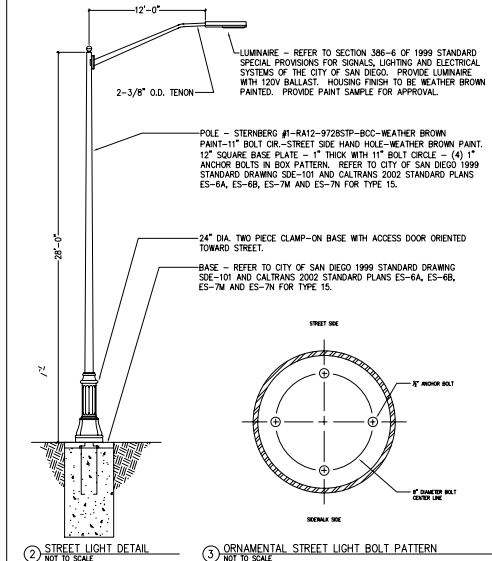

2 STREET LIGHT DETAIL NOT TO SCALE

3 ORNAMENTAL STREET LIGHT BOLT PATTERN NOT TO SCALE

DEL SUR - PUBLIC STREET LIGHT EXHIBIT



CLIENT: Black Mountain Ranch LLC
CONSULTANT: Wimmer Yamada and Caughey
DATE: February 24, 2006

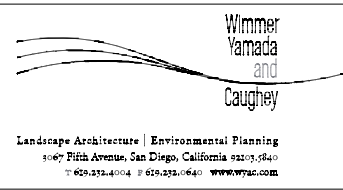

Assessment Law, only “special benefits” are assessable. As such, isolation and quantification of the “special benefits” associated with the improvements and activities are paramount, and illustrated in the following equations:

$$\text{Special Benefits} = \text{Total Benefits} - \text{General Benefits}$$

$$\text{General Benefits} = \text{City Standard} + \text{External Benefits}$$

$$\text{Special Benefits} = \text{Total Benefits} - [\text{City Standard} + \text{External Benefits}]$$

In these equations, “Total Benefits” refers to the cost of providing the total benefits of the improvements and activities; “City Standard” represents the cost of providing the City’s standard level of service; and “External Benefits” refers to the cost of those additional benefits accruing to the public at large or properties located outside the District. In order to isolate the “Special Benefits,” it is necessary to quantify the amount of “General Benefits” associated with the improvements and activities.

City Standard

As a “general benefit” (not funded by assessments), the District will continue to receive the standard level of service provided to the public at large under City-funded and administered programs for maintenance and servicing of public facilities and improvements (e.g., medians, open space, street lights, street trees, sidewalks, parks, etc.), including street sweeping and graffiti removal on public property. Consistent with City policy for the public at large, the City will contribute for lighting maintenance and energy costs an amount equivalent to that used for City minimum required streetlights (see *City Council Policy 200-18* for lighting standards). These levels of service, reviewed and adjusted annually by the City, are “general benefits” administered by the District. **Table 1** provides a summary of lighting fixtures by zone, and a quantification of those fixtures in excess of the City standard.

External Benefits

Assessment Law prohibits levying assessments to pay for “general benefits” conferred to the public at large or properties located outside the District. Based on a review of the spatial limits of the District and the improvements and activities, it has been determined that the improvements and activities have the potential to confer benefits to others outside the District.

It is estimated as much as 1.2% of the total benefit (in excess of the City standard) may accrue to the public at large or properties located outside the District (with an estimated 0.0% accruing directly to properties located outside the District, and the remaining 1.2% accruing to the general public as indirect/incidental beneficiaries passing through the District or utilizing District-provided amenities). The estimated costs associated with these “general benefits” have been quantified and will not be funded by assessment.

TABLE 1: Lighting Fixture Count by Zone

	ZONE								Total
	A ⁽¹⁾	B	C	D	E	F	G	H	
Total Fixture Count									
■ Acorn Style	61	4	0	140	95	65	28	18	411
■ Cobra Style	131	0	5	0	4	0	0	0	140
Total:	192	4	5	140	99	65	28	18	551
City Standard Fixture Count ⁽²⁾									
■ Acorn Style	26	4	0	72	48	48	14	9	221
■ Cobra Style	131	0	5	0	4	0	0	0	140
Total	157	4	5	72	52	48	14	9	361
Fixtures In Excess of City Standard ⁽³⁾									
■ Acorn Style	35	0	0	68	47	17	14	9	190
■ Cobra Style	0	0	0	0	0	0	0	0	0
Total	35	0	0	68	47	17	14	9	190

⁽¹⁾ Overlay lighting fixtures (located along Camino Del Sur and Paseo Del Sur).

⁽²⁾ Acorn style fixture count for “general benefit” energy contribution purposes only. Maintenance of acorn style light fixtures is entirely a “special benefit.”

⁽³⁾ Identified based on standard street light spacing requirements.

Cost Estimate

Estimated Costs

Estimated Fiscal Year 2017 annual expenses, revenues, reserves, and assessments (provided by the City) are included as **Exhibit B** hereto.

Annual Cost-Indexing

With the passage of Proposition 218, any proposed increase in assessments must be placed for approval before the property owners by a mail ballot and a public hearing process, similar to these proceedings. A majority of ballots received must be affirmative for the City Council to confirm and levy the increased assessments. For small assessment districts or districts with relatively low dollar assessments, the cost of an engineer’s report, balloting, and the public hearing

process can potentially exceed the total cost of the increase. These incidental costs of the proceedings can be added to the assessments, resulting in even higher assessments.

Indexing assessments annually to the San Diego Consumer Price Index for Urban Consumers (SDCPI-U) plus 3%, as approved by the District property owners in Fiscal Year 2007, allows for minor increases for normal maintenance and operating cost escalation without incurring the costs of the Proposition 218 ballot proceedings. Any significant change in the assessment initiated by an increase in service provided or other significant changes to the District would still require the Proposition 218 proceedings and property owner approval.

The maximum authorized assessment established in the Fiscal Year 2007 proceedings are authorized to be indexed (increased or decreased) annually by the factor published in the SDCPI-U plus 3%. The annual change in second half SDCPI-U values, as compiled by the *U.S. Bureau of Labor Statistics* (see www.bls.gov), for the prior year period was from 265.039 to 271.526 (a 2.45% increase). In accordance with the approved cost-indexing provisions, the maximum authorized assessment rates contained within this Assessment Engineer's Report have been increased by 5.45%.

Method of Apportionment

Estimated Benefit of Improvements

The Community Design Element of the *Black Mountain Ranch Subarea Plan* (Subarea Plan) and the general policy recommendations found in the City's *Progress Guide & General Plan* (General Plan) establish several goals and guidelines for the planned development of the community. The District improvements and activities are consistent with these goals. The City's General Plan and Subarea Plan support the establishment of community-based improvement and maintenance districts, such as this District, to fund enhanced improvements and activities.

Camino Del Sur & Paseo Del Sur

Collectively, Camino Del Sur and Paseo Del Sur make up the backbone street network for the community. These streets serve as the primary access routes for inter-community and intra-community trips, serving all parcels within the community. All parcels within the District benefit from the aesthetic enhancement of these streets and the enhanced community image provided by District improvements and activities. As such, all parcels within

the District have been assessed for the improvements and activities on Camino Del Sur and Paseo Del Sur. The assessment costs associated with these improvements and activities (common to all parcels) are termed “overlay” costs.

Other Collector & Neighborhood Streets

The other collector and neighborhood streets serve as the primary access routes to and from the backbone street system, serving parcels within a specific area. Only those parcels served by such collector and neighborhood streets benefit from their enhancement. Consistent with this concept, the District has been divided into eight zones as shown in **Exhibit A**. The assessment costs associated with improvements and activities located along the other collector and neighborhood streets are termed “zone” costs.

Apportionment Methodology

The total cost associated with District improvement and activities will be assessed proportionally to the parcels in the District based on Equivalent Benefit Units (EBUs). The total assessment for a given parcel is equal to the parcel’s total EBUs multiplied by the Unit Assessment Rate (unique to the zone in which parcel is situated) as shown in the following equation:

$\text{Total Assessment} = \text{Total EBUs} \times \text{Unit Assessment Rate}$
--

Equivalent Benefit Units (EBUs)

EBUs for each parcel have been determined as a function of parcel area or number of residential units and a Land Use Factor, as shown in the following equation:

$\text{EBUs} = (\text{Acres or Units}) \times \text{Land Use Factor}$

Parcels determined to receive no benefit from District improvements and activities have been assigned zero (0) EBUs.

Land Use Factor

Since the proposed District improvements and activities are primarily associated with the Transportation Element of City’s General Plan and Community Plan, trip generation rates for various land use categories (as previously established by the City’s Transportation Planning Section) have been used as the primary

basis for the development of Land Use Factors. While these trip generation rates address vehicular trips, they are also considered to approximately reflect relative trip generation for other modes of transportation (e.g., pedestrian trips, bicycle trips, etc.), and are considered the best available information for these other transportation modes.

Trip generation rates provide the required nexus and basis for assigning relative proportionality of potential benefit to the various land use/zoning classifications (as defined by the City’s Municipal Code) within the District. Land use/zoning classifications have been grouped with averaged trip generation rates assigned to establish the Land Use Factors as shown in **Table 2**.

TABLE 2: Land Use Factors

Land Use/Zoning	Code	Land Use Factor ⁽¹⁾
Residential – Single Family (detached)	SFD	1.0 per dwelling unit
Residential – Condominium	CND	0.7 per dwelling unit
Residential – Multi-Family & Apartment	MFR	0.7 per dwelling unit
Commercial – Office & Retail	COM	45.0 per acre
Educational – Primary & Secondary	EPS	5.0 per acre
Fire/Police Station	FPS	15.0 per acre
Golf Course	GLF	0.80 per acre
Hotel	HTL	15.0 per acre
Industrial & Institutional	IND	15.0 per acre
Open Space (designated)	OSP	0 per acre
Park – Developed	PKD	5.0 per acre
Park – Undeveloped	PKU	0.5 per acre
Recreational Facility	REC	3.0 per acre
Street/Roadway	STR	0 per acre
Transit Station	TRN	30.0 per acre
Street/Roadway	STR	0 per acre
Undevelopable	UND	0 per acre
Utility Facility	UTL	3.0 per acre

⁽¹⁾ Proportional to trip generation rates contained in the City of San Diego *Trip Generation Manual* (May 2003).

Designated open space serves primarily to preserve natural landscape and habitat. While access for study and passive recreation is often permitted, these activities are allowed only to the extent they are consistent with the primary purpose of natural preservation. Since this land is essentially “unused” in the customary terms of land use (which relate to human use and development), the trip generation rate is zero. Therefore, the designated open space itself receives no benefit from the District improvements and activities and has been assigned a Land Use

Factor of zero.

While those traveling the streets and roadways visually enjoy the enhanced District improvements and activities, the actual benefit accrues to the lands at the origins and destinations of their trips, not to the lands of the streets and roadways, themselves. Accordingly, the Streets/Roadways category receives no benefit and has been assigned a Land Use Factor of zero.

The Recreational Facility category includes those parcels that consist primarily of concentrated facilities, such as swimming pools, gymnasiums, racquetball clubs, etc. Recreational facilities of a more dispersed nature (e.g., parks, golf courses, etc.) have been categorized separately.

Unit Assessment Rates

As previously mentioned, all parcels have been assessed for the District improvements and activities located along Camino Del Sur and Paseo Del Sur. The assessment costs associated with these improvements and activities (common to all parcels) are termed “overlay” costs. Parcels within each zone have been assessed for the improvements and activities on the collector and neighborhood streets serving their respective zone. The assessment costs associated with these improvements and activities are termed “zone” costs.

The total “overlay” costs have been apportioned to each parcel in proportion to the parcel’s estimated EBUs relative to the total of all District EBUs. The total “zone” costs have been apportioned to each parcel in proportion to the parcel’s estimated EBUs relative to the total of all EBUs within the zone.

The Unit Assessment Rate (rate per EBU) is equal to the sum of the “overlay” unit rate and the “zone” unit rate as shown in the following equation:

$\text{Unit Assessment Rate} = \text{Overlay Unit Rate} + \text{Zone Unit Rate}$
--

Table 3 summarizes the Fiscal Year 2017 and maximum authorized unit assessment rates.

TABLE 3: Fiscal Year 2017 & Maximum Authorized Unit Assessment Rates

	Unit Assessment Rate by Zone							
	A	B	C	D	E	F	G	H
Fiscal Year 2017 ⁽¹⁾								
Overlay Unit Rate	\$0.00	\$0.00	\$0.00	\$0.00	\$0.00	\$0.00	\$0.00	\$0.00
Zone Unit Rate	\$0.00	\$0.00	\$0.00	\$0.00	\$0.00	\$0.00	\$0.00	\$0.00
Unit Assessment Rate	\$0.00	\$0.00	\$0.00	\$0.00	\$0.00	\$0.00	\$0.00	\$0.00
Maximum Authorized ⁽²⁾⁽³⁾								
Unit Assessment Rate	\$17.16	\$276.91	\$45.21	\$213.48	\$163.05	\$47.75	\$57.13	\$33.82

⁽¹⁾ Fiscal Year 2017 begins July 1, 2016 and ends June 30, 2017.

⁽²⁾ Prior fiscal year's maximum authorized annual assessment increased by cost-indexing factor of 5.45

⁽³⁾ Subject to cost-indexing provisions set forth in this Assessment Engineer's Report.

Sample Calculations

As described above, the number of Equivalent Benefit Units (EBUs) assigned to each parcel in the District has been calculated based on each parcel's land use and the identified apportionment factors, as shown in the following equation:

$\text{EBUs} = (\text{Acres or Units}) \times \text{Land Use Factor}$

Shown below are sample EBU calculations for several common land uses found in the District.

- **1 Single-Family Residence**
EBUs = 1 unit x 1.00 = 1.00 EBUs
- **1 Condominium**
EBUs = 1 unit x 0.70 = 0.70 EBUs
- **10-unit Apartment Complex**
EBUs = 10 units x 0.70 = 7.00 EBUs
- **½-acre Commercial Property**
EBUs = 0.50 acres x 45.00 = 22.50 EBUs

The total assessment for each parcel in the District is based on the calculated EBUs for the parcel and the applicable unit assessment rate for the zone in which the parcel is located, as shown in the following equation:

$$\text{Total Assessment} = \text{Total EBUs} \times \text{Unit Assessment Rate}$$

Based on the above formula, the EBUs, unit assessment rate, and total assessment calculated for each property, can be found in the Assessment Roll (**Exhibit C**).

Summary Results

The District Boundary is presented in **Exhibit A**.

An estimate of the costs of the improvements and activities provided by the District is included as **Exhibit B** to this report.

The assessment methodology utilized is as described in the text of this report. Based on this methodology, the EBUs and Fiscal Year 2017 District assessment for each parcel were calculated and are shown in the Assessment Roll (**Exhibit C**).

Each lot or parcel of land within the District has been identified by unique County Assessor's Parcel Number on the Assessment Roll and the Boundary Map and Assessment Diagram referenced herein. The net assessment for each parcel for Fiscal Year 2017 can be found on the Assessment Roll.

This report has been prepared and respectfully submitted by:



Eugene F. Shank

Eugene F. Shank, PE

C 52792

Sharon F. Risse

Sharon F. Risse

I, _____, as CITY CLERK of the CITY OF SAN DIEGO, COUNTY OF SAN DIEGO, CALIFORNIA, do hereby certify that the Assessment as shown on the Assessment Roll, together with the Assessment Diagram, both of which are incorporated into this report, were filed in my office on the ____ day of _____, 2016.

Elizabeth Maland, CITY CLERK
CITY OF SAN DIEGO
STATE OF CALIFORNIA

I, _____, as CITY CLERK of the CITY OF SAN DIEGO, COUNTY OF SAN DIEGO, CALIFORNIA, do hereby certify that the foregoing Assessment, together with the Assessment Diagram incorporated into this report, was approved and confirmed by the CITY COUNCIL of said City on the ____ day of _____, 2016.

Elizabeth Maland, CITY CLERK
CITY OF SAN DIEGO
STATE OF CALIFORNIA

EXHIBIT A



BOUNDARY MAP & ASSESSMENT DIAGRAM

FILED IN THE OFFICE OF THE CITY CLERK OF THE CITY OF SAN DIEGO, STATE OF CALIFORNIA, THIS ____ DAY OF _____, 2006.

ELIZABETH MALAND, CITY CLERK
CITY OF SAN DIEGO
STATE OF CALIFORNIA

PREPARED BY:
BOYLE ENGINEERING CORPORATION
7807 Conroy Court, Suite 200, San Diego, California 92111 (659) 268-8080

I HEREBY CERTIFY THAT THE WITHIN MAP SHOWING PROPOSED BOUNDARIES OF THE BLACK MOUNTAIN RANCH NORTH MAINTENANCE ASSESSMENT DISTRICT, CITY OF SAN DIEGO, STATE OF CALIFORNIA, WAS APPROVED BY THE CITY COUNCIL AT A REGULAR MEETING THEREOF, HELD ON THE ____ DAY OF _____, 2006, BY ITS RESOLUTION NO. _____.

ELIZABETH MALAND, CITY CLERK
CITY OF SAN DIEGO
STATE OF CALIFORNIA

AN ASSESSMENT WAS LEVIED BY THE CITY COUNCIL OF THE CITY OF SAN DIEGO ON THE LOTS, PIECES, AND PARCELS OF LAND SHOWN ON THIS ASSESSMENT DIAGRAM, SAID ASSESSMENT WAS LEVIED ON THE ____ DAY OF _____, 2006; SAID ASSESSMENT DIAGRAM AND THE ASSESSMENT ROLL WERE RECORDED IN THE OFFICE OF THE SUPERINTENDENT OF STREETS OF THE CITY OF SAN DIEGO, STATE OF CALIFORNIA ON THE ____ DAY OF _____, 2006. REFERENCE IS MADE TO THE ASSESSMENT ROLL RECORDED IN THE OFFICE OF THE SUPERINTENDENT OF STREETS FOR THE EXACT AMOUNT OF EACH ASSESSMENT LEVIED AGAINST EACH PARCEL OF LAND SHOWN ON THIS ASSESSMENT DIAGRAM.

LEGEND:

- District Boundary
- - - Zone Boundary
- Parcel Line

NOTE:
FOR A DETAILED DESCRIPTION OF THE LINES AND DIMENSIONS OF LOTS OR PARCELS SHOWN ON THIS MAP, REFER TO THE COUNTY ASSESSOR'S MAPS WHICH SHALL GOVERN WITH RESPECT TO ALL DETAILS CONCERNING THE LINES AND DIMENSIONS OF SUCH LOTS OR PARCELS.

REFER TO THE ENGINEER'S REPORT AND REFERENCED DOCUMENTS, INCORPORATED HEREIN BY REFERENCE, FOR LOCATION AND TYPE OF IMPROVEMENTS.



CITY OF
SAN DIEGO

BLACK MOUNTAIN RANCH NORTH MAINTENANCE ASSESSMENT DISTRICT

EXHIBIT B

EXHIBIT B

Park and Recreation Department - Open Space Division
Maintenance Assessment Districts Program
Summary of Fiscal Year 2017 (07-01-16 to 06-30-17) Budget

**Black Mountain Ranch North Maintenance Assessment District
Fund 200089**

	FY 2015 Unaudited Actuals	FY 2016 Estimate	FY 2017 Proposed
<u>District Expenses</u>			
Street Division Maintenance Charges	\$ -	\$ 30,250.00	\$ 33,275.00
Electrician/Lighting Inspector	\$ -	\$ 40,838.00	\$ 44,922.00
Special Districts Administration	\$ 10,998.00	\$ 11,217.96	\$ 11,442.00
Vehicle Usage & Assignment	\$ 777.00	\$ 815.85	\$ 857.00
.10 FTE Grounds Maintenance Manager - Contract Administrator (Total Labor & Fringe)	\$ 11,577.00	\$ 11,808.54	\$ 12,045.00
Subtotal Supplies and Services	\$ 23,352.00	\$ 94,930.35	\$ 102,541.00
Utilities: Energy - Special District Street Lighting	\$ -	\$ -	\$ -
Subtotal Utilities	\$ -	\$ -	\$ -
TOTAL EXPENSE	\$ 23,352.00	\$ 94,930.35	\$ 102,541.00
<u>District Revenues</u>			
Special Assessments	\$ -	\$ -	\$ -
Interest Earnings	\$ 3,794.34	\$ 2,900.00	\$ 2,400.00
Street Light Damage (1600 Cmo Del Sur - File #65034/Nazif)	\$ 3,413.70	\$ -	\$ -
General Benefit Offset, 1.2%	\$ 1,055.72	\$ 124.47	\$ - ⁽¹⁾
TOTAL REVENUE	\$ 8,263.76	\$ 3,024.47	\$ 2,400.00
<u>District Reserves</u>			
Beginning Fund Balance	\$ 693,280.55	\$ 678,451.40	\$ 586,545.52
Change in Fund Balance	\$ (14,829.15)	\$ (91,905.88)	\$ (100,141.00)
Year End Operating Reserves	\$ 678,451.40	\$ 586,545.52	\$ 486,404.52

⁽¹⁾ General Benefit Offset contribution adjusted for prior year overpayments.

EXHIBIT C

EXHIBIT C - Assessment Roll (Fiscal Year 2017)
Black Mountain Ranch North Maintenance Assessment District

Parcel Number	Acres/ Units ⁽¹⁾	Land Use Code ⁽²⁾	Zone	Land Use Factor ⁽²⁾	Total EBUs	Unit Cost (\$/Ebu)	FY 2017 ⁽³⁾ Assessment	Owner Name
267 150 07 00	2.52	STR	A	0.00	0.00	\$0.00	\$0.00	Black Mountain Ranch L L C
267 150 13 00	7.17	OSP	A	0.00	0.00	\$0.00	\$0.00	Black Mountain Ranch L L C
267 150 30 00	65.46	OSP	A	0.00	0.00	\$0.00	\$0.00	Black Mountain Ranch L L C
267 150 32 00	0.05	OSP	C	0.00	0.00	\$0.00	\$0.00	Black Mountain Ranch L L C
267 150 36 00	0.68	UTL	A	3.00	2.04	\$0.00	\$0.00	City Of San Diego
267 150 39 00	286.46	GLF	A	0.80	229.17	\$0.00	\$0.00	Black Mountain Ranch L L C
267 231 01 00	1.00	SFD	D	1.00	1.00	\$0.00	\$0.00	Dohring Arjay&Leeann
267 231 02 00	1.00	SFD	D	1.00	1.00	\$0.00	\$0.00	Wallace Paul A&Shelley L
267 231 03 00	1.00	SFD	D	1.00	1.00	\$0.00	\$0.00	Kotta Kishore K&Devaki Uma
267 231 04 00	1.00	SFD	D	1.00	1.00	\$0.00	\$0.00	Shanmugam Sengoutouwane&Veerasamy Kavitha
267 231 05 00	1.00	SFD	D	1.00	1.00	\$0.00	\$0.00	Spelta John J&Claire Y
267 231 06 00	1.00	SFD	D	1.00	1.00	\$0.00	\$0.00	Lee Bryan
267 231 07 00	1.00	SFD	D	1.00	1.00	\$0.00	\$0.00	Nelson Robert L Jr&Rhea R
267 231 08 00	1.00	SFD	D	1.00	1.00	\$0.00	\$0.00	Smurlo Daniel&Albana Family 2014 Trust
267 231 09 00	1.00	SFD	D	1.00	1.00	\$0.00	\$0.00	Escobedo Family Trust 06-18-15
267 231 10 01	1.00	SFD	D	1.00	1.00	\$0.00	\$0.00	Latourette Sherrie T Revocable 2009 Trust 09-11-09 Et Al
267 231 10 02	1.00	SFD	D	1.00	1.00	\$0.00	\$0.00	Itakura Nobuyasu&Pham Mai Thi
267 231 11 01	1.00	SFD	D	1.00	1.00	\$0.00	\$0.00	Ding Victor&Chen Zoe Living Trust 05-02-15
267 231 11 02	1.00	SFD	D	1.00	1.00	\$0.00	\$0.00	Cooper Jack A
267 231 12 01	1.00	SFD	D	1.00	1.00	\$0.00	\$0.00	Sea Island Investment Trust 03-20-14
267 231 12 02	1.00	SFD	D	1.00	1.00	\$0.00	\$0.00	Challagulla Ravikanth&Samala Abhigna
267 231 13 01	1.00	SFD	D	1.00	1.00	\$0.00	\$0.00	Montanari Michael S
267 231 13 02	1.00	SFD	D	1.00	1.00	\$0.00	\$0.00	Becker Gregory F&Pamela J
267 231 14 01	1.00	SFD	D	1.00	1.00	\$0.00	\$0.00	Reist Troy K&Veronica L
267 231 14 02	1.00	SFD	D	1.00	1.00	\$0.00	\$0.00	Cassel Jordan&Erica L
267 231 15 01	1.00	SFD	D	1.00	1.00	\$0.00	\$0.00	Shin John H&Rayna N
267 231 15 02	1.00	SFD	D	1.00	1.00	\$0.00	\$0.00	Toman Jeremy P&Jeeyon J
267 231 16 01	1.00	SFD	D	1.00	1.00	\$0.00	\$0.00	Langford Living Trust 07-08-13
267 231 16 02	1.00	SFD	D	1.00	1.00	\$0.00	\$0.00	Darugar Mustafa&Chandio Aliya
267 231 17 00	0.28	STR	D	0.00	0.00	\$0.00	\$0.00	Standard Pacific Corp
267 231 18 00	1.00	SFD	D	1.00	1.00	\$0.00	\$0.00	Power Michael E&Megan
267 231 19 00	1.00	SFD	D	1.00	1.00	\$0.00	\$0.00	Ganz Andrew N
267 231 20 00	1.00	SFD	D	1.00	1.00	\$0.00	\$0.00	Srinivasan Mayur&Bhandarkar Saritha
267 231 21 00	1.00	SFD	D	1.00	1.00	\$0.00	\$0.00	Young Family Trust 03-31-09
267 231 22 00	1.00	SFD	D	1.00	1.00	\$0.00	\$0.00	Warren Robert O&Bethany D
267 231 23 00	1.00	SFD	D	1.00	1.00	\$0.00	\$0.00	Kumar Atin&Bhatnagar Meghna
267 231 24 00	1.00	SFD	D	1.00	1.00	\$0.00	\$0.00	Patrawala Family Trust 04-23-07
267 231 25 00	1.00	SFD	D	1.00	1.00	\$0.00	\$0.00	Palmer-Jeffery Richard&Marie
267 231 26 00	1.00	SFD	D	1.00	1.00	\$0.00	\$0.00	Coronel Edwin&Karoline
267 231 27 00	1.00	SFD	D	1.00	1.00	\$0.00	\$0.00	Mikolajewski Peter J Tr&Mikolajewski Sandra M Tr
267 231 28 00	1.00	SFD	D	1.00	1.00	\$0.00	\$0.00	Kumar Praveen&Ratna
267 231 29 00	1.00	SFD	D	1.00	1.00	\$0.00	\$0.00	Gilding Jerome A&Trina L
267 231 30 00	1.00	SFD	D	1.00	1.00	\$0.00	\$0.00	Levy Brian C
267 231 31 00	1.00	SFD	D	1.00	1.00	\$0.00	\$0.00	Painter Tyler&Jessica 2010 Trust 09-17-10
267 231 32 00	1.00	SFD	D	1.00	1.00	\$0.00	\$0.00	Sadagopan Vijaykrishna&Ravichandran Divya
267 231 33 00	1.00	SFD	D	1.00	1.00	\$0.00	\$0.00	Le Thuy D&Le-Pham Van T
267 231 34 00	1.00	SFD	D	1.00	1.00	\$0.00	\$0.00	Kerrin Stephen&Erica
267 231 35 00	1.00	SFD	D	1.00	1.00	\$0.00	\$0.00	Puorro Gerard E Jr&Elizabeth T
267 231 36 00	1.00	SFD	D	1.00	1.00	\$0.00	\$0.00	Nguyen Van Tuyet
267 231 37 00	1.00	SFD	D	1.00	1.00	\$0.00	\$0.00	Patibandla Suresh Babu&Sowmya SriIatha
267 231 38 00	1.00	SFD	D	1.00	1.00	\$0.00	\$0.00	Walther Family Trust 08-08-11
267 231 39 00	1.00	SFD	D	1.00	1.00	\$0.00	\$0.00	Chang Su Hwau&Sami Y
267 231 40 00	1.00	SFD	D	1.00	1.00	\$0.00	\$0.00	Mcgibbons Jennifer M
267 231 41 00	1.00	SFD	D	1.00	1.00	\$0.00	\$0.00	Nabbi Family Trust 09-12-13
267 231 42 00	1.00	SFD	D	1.00	1.00	\$0.00	\$0.00	Tagulao Michael T
267 231 43 00	1.00	SFD	D	1.00	1.00	\$0.00	\$0.00	Massire Christian
267 231 44 00	1.00	SFD	D	1.00	1.00	\$0.00	\$0.00	Turner David W&Rosemary E
267 231 45 00	1.00	SFD	D	1.00	1.00	\$0.00	\$0.00	Jones Wilbur G&Galli-Tognota Vittoria
267 231 46 00	1.00	SFD	D	1.00	1.00	\$0.00	\$0.00	Pun Ka Shun Carson&Wong Mong Chit

EXHIBIT C - Assessment Roll (Fiscal Year 2017)
Black Mountain Ranch North Maintenance Assessment District

Parcel Number	Acres/ Units ⁽¹⁾	Land Use Code ⁽²⁾	Zone	Land Use Factor ⁽²⁾	Total EBUs	Unit Cost (\$/EUBU)	FY 2017 ⁽³⁾ Assessment	Owner Name
267 231 47 00	1.00	SFD	D	1.00	1.00	\$0.00	\$0.00	Dahl Daniel J&Tesa T
267 231 48 00	1.00	SFD	D	1.00	1.00	\$0.00	\$0.00	Jagoliner Family Trust 11-12-15
267 231 49 00	1.00	SFD	D	1.00	1.00	\$0.00	\$0.00	Sarralde Juan P
267 231 50 00	1.00	SFD	D	1.00	1.00	\$0.00	\$0.00	Dao Thao
267 231 51 00	1.00	SFD	D	1.00	1.00	\$0.00	\$0.00	Wong Michael H&Lee Mimi A
267 231 52 00	1.00	SFD	D	1.00	1.00	\$0.00	\$0.00	Ashton Matthew J&Kimberly W
267 231 53 00	1.00	SFD	D	1.00	1.00	\$0.00	\$0.00	Lown Ryan D&Megan S
267 231 54 00	0.02	OSP	D	0.00	0.00	\$0.00	\$0.00	Del Sur Community Assn
267 231 55 00	0.18	STR	D	0.00	0.00	\$0.00	\$0.00	Del Sur Community Assn
267 231 56 00	0.02	OSP	D	0.00	0.00	\$0.00	\$0.00	Del Sur Community Assn
267 231 57 00	0.97	PKU	D	0.50	0.49	\$0.00	\$0.00	Black Mountain Ranch L L C
267 232 01 00	1.00	SFD	D	1.00	1.00	\$0.00	\$0.00	Burnett Nathan J&Erika L
267 232 02 00	1.00	SFD	D	1.00	1.00	\$0.00	\$0.00	Galan Marcos C Iii&Victoria D
267 232 03 00	1.00	SFD	D	1.00	1.00	\$0.00	\$0.00	Okeefe Thomas P Iii&Shalane
267 232 04 00	1.00	SFD	D	1.00	1.00	\$0.00	\$0.00	Chakravarthula Prashanth&Ganjam Anitha
267 232 05 00	1.00	SFD	D	1.00	1.00	\$0.00	\$0.00	Dempster Joseph M&Erin B
267 232 06 00	1.00	SFD	D	1.00	1.00	\$0.00	\$0.00	Dennison Family 2003 Trust 06-26-03
267 232 07 00	1.00	SFD	D	1.00	1.00	\$0.00	\$0.00	Styles Andrew G&Masako K
267 232 08 00	1.00	SFD	D	1.00	1.00	\$0.00	\$0.00	Charoen Don&Erin J
267 232 09 00	1.00	SFD	D	1.00	1.00	\$0.00	\$0.00	Endicott Eric&Heather
267 232 10 00	1.00	SFD	D	1.00	1.00	\$0.00	\$0.00	Light Dion W&Elizabeth C
267 232 11 00	1.00	SFD	D	1.00	1.00	\$0.00	\$0.00	Connelly Jeffy J Sr&Fabiana S
267 232 12 00	1.00	SFD	D	1.00	1.00	\$0.00	\$0.00	Arora Monica
267 232 13 00	1.00	SFD	D	1.00	1.00	\$0.00	\$0.00	Concord Living Trust 12-23-15
267 232 14 00	1.00	SFD	D	1.00	1.00	\$0.00	\$0.00	Hurvitz Aaron D&Lindsey
267 232 15 00	1.00	SFD	D	1.00	1.00	\$0.00	\$0.00	Desai Preyas&Sheth Bishwa
267 232 16 00	1.00	SFD	D	1.00	1.00	\$0.00	\$0.00	Pinderski Eric&Soukahn
267 232 17 00	1.00	SFD	D	1.00	1.00	\$0.00	\$0.00	Cressman William S&Juliana A
267 232 18 00	1.00	SFD	D	1.00	1.00	\$0.00	\$0.00	Rajakumar Chandramohan&Gaffoor Sharifa B
267 232 19 00	1.00	SFD	D	1.00	1.00	\$0.00	\$0.00	Vartak Aniket&Kalra Ashmeet
267 232 20 00	1.00	SFD	D	1.00	1.00	\$0.00	\$0.00	Yu Ning
267 232 21 00	1.00	SFD	D	1.00	1.00	\$0.00	\$0.00	Maeda Yu G&Summer F
267 232 22 00	1.00	SFD	D	1.00	1.00	\$0.00	\$0.00	Federhart Shelley A
267 232 23 00	1.00	SFD	D	1.00	1.00	\$0.00	\$0.00	Brahmbhatt Shardul K
267 232 24 00	1.00	SFD	D	1.00	1.00	\$0.00	\$0.00	Coleman Patrick J&Michelle M
267 232 25 00	1.00	SFD	D	1.00	1.00	\$0.00	\$0.00	Siedeman G D Trust No 3 06-30-11
267 232 26 00	1.00	SFD	D	1.00	1.00	\$0.00	\$0.00	Fonss Christian P Jr Trust 11-06-09
267 232 27 00	1.00	SFD	D	1.00	1.00	\$0.00	\$0.00	Rupp Ted P&Karla C
267 232 28 00	1.00	SFD	D	1.00	1.00	\$0.00	\$0.00	Payumo Elaine
267 232 29 00	1.00	SFD	D	1.00	1.00	\$0.00	\$0.00	Sooy Kevin A
267 232 30 00	1.00	SFD	D	1.00	1.00	\$0.00	\$0.00	Giampaoli Justin&Mirabelle
267 232 31 00	1.00	SFD	D	1.00	1.00	\$0.00	\$0.00	Johnson Jeffrey F&Lisa B
267 232 32 00	1.00	SFD	D	1.00	1.00	\$0.00	\$0.00	Barrera Marcos&Kirsten
267 232 33 00	1.00	SFD	D	1.00	1.00	\$0.00	\$0.00	Monenschein Holger&Stephanie
267 232 34 00	1.00	SFD	D	1.00	1.00	\$0.00	\$0.00	Mogul Homyar C&Pervin
267 232 35 00	1.00	SFD	D	1.00	1.00	\$0.00	\$0.00	Ramirez Alfredo R&Courtney M
267 232 36 00	1.00	SFD	D	1.00	1.00	\$0.00	\$0.00	Hassanzadeh Basir&Parwana
267 232 37 00	1.00	SFD	D	1.00	1.00	\$0.00	\$0.00	Aroonlap Paiboon&Juthamas T
267 232 38 00	1.00	SFD	D	1.00	1.00	\$0.00	\$0.00	Faulk Maria C
267 232 39 00	1.00	SFD	D	1.00	1.00	\$0.00	\$0.00	Lorenzen Jonathan J&Kari A
267 232 40 00	1.00	SFD	D	1.00	1.00	\$0.00	\$0.00	Kline Brent C&Kelly K Family Trust
267 232 41 00	1.00	SFD	D	1.00	1.00	\$0.00	\$0.00	Dennison Family 2003 Trust 06-26-03
267 232 42 00	1.00	SFD	D	1.00	1.00	\$0.00	\$0.00	Peyser Gregory R&Whitney S
267 232 43 00	1.00	SFD	D	1.00	1.00	\$0.00	\$0.00	Michtchenko Rouslan V&Dmitrieva Olga K
267 232 44 00	1.00	SFD	D	1.00	1.00	\$0.00	\$0.00	Lennick Paul&Nariman
267 232 45 00	1.00	SFD	D	1.00	1.00	\$0.00	\$0.00	Singer Robert L Jr&Amy N
267 232 46 00	1.00	SFD	D	1.00	1.00	\$0.00	\$0.00	Cheng Wei&Wang Wei
267 232 47 00	1.00	SFD	D	1.00	1.00	\$0.00	\$0.00	Murphy Thomas&Patricia Trust 12-03-01
267 232 48 00	1.00	SFD	D	1.00	1.00	\$0.00	\$0.00	Milner Christy

EXHIBIT C - Assessment Roll (Fiscal Year 2017)
Black Mountain Ranch North Maintenance Assessment District

Parcel Number	Acres/ Units ⁽¹⁾	Land Use Code ⁽²⁾	Zone	Land Use Factor ⁽²⁾	Total EBUs	Unit Cost (\$/EUBU)	FY 2017 ⁽³⁾ Assessment	Owner Name
267 232 49 00	1.00	SFD	D	1.00	1.00	\$0.00	\$0.00	Brittain Grant
267 232 50 00	1.00	SFD	D	1.00	1.00	\$0.00	\$0.00	Frost Andrew J&Allegra D
267 232 51 00	1.00	SFD	D	1.00	1.00	\$0.00	\$0.00	Gillespie Donald S&Kimberly H
267 232 52 00	1.00	SFD	D	1.00	1.00	\$0.00	\$0.00	Ladow Kenneth G&Britney C
267 232 53 00	1.00	SFD	D	1.00	1.00	\$0.00	\$0.00	Childs Tracie L
267 232 54 00	1.00	SFD	D	1.00	1.00	\$0.00	\$0.00	Desai Shiv R
267 232 55 00	1.00	SFD	D	1.00	1.00	\$0.00	\$0.00	Fontes Kellie A
267 232 56 00	1.00	SFD	D	1.00	1.00	\$0.00	\$0.00	Cheng Wesley
267 232 57 00	1.00	SFD	D	1.00	1.00	\$0.00	\$0.00	Khurana Varun&Atica
267 232 58 00	1.00	SFD	D	1.00	1.00	\$0.00	\$0.00	Hamatanga Sipho Fred&Petrina M
267 232 59 00	1.00	SFD	D	1.00	1.00	\$0.00	\$0.00	Sutter Cameron&Nedic Ivana
267 232 60 00	1.00	SFD	D	1.00	1.00	\$0.00	\$0.00	Shah Tejash&Sethia Nisha
267 232 61 00	1.00	SFD	D	1.00	1.00	\$0.00	\$0.00	Lee Ho Sang&Soon Ae
267 232 62 00	1.00	SFD	D	1.00	1.00	\$0.00	\$0.00	Ouk Jonathan Chan&Shu Chi Liu
267 232 63 00	1.00	SFD	D	1.00	1.00	\$0.00	\$0.00	Biele Chris&Kelly
267 232 64 00	1.00	SFD	D	1.00	1.00	\$0.00	\$0.00	Filoteo Manuel G&Rufina S
267 232 65 00	1.00	SFD	D	1.00	1.00	\$0.00	\$0.00	Ramkumar Vasanth K&Vandhana Smruthi
267 232 66 00	1.00	SFD	D	1.00	1.00	\$0.00	\$0.00	Efe Baris&Neslihan
267 232 67 00	1.00	SFD	D	1.00	1.00	\$0.00	\$0.00	Chou Weilin&Chi Annie
267 232 68 00	1.00	SFD	D	1.00	1.00	\$0.00	\$0.00	Shen Zancong&Yao Hongtao
267 232 69 00	1.00	SFD	D	1.00	1.00	\$0.00	\$0.00	Patrick William J&Kristin A
267 232 70 00	1.00	SFD	D	1.00	1.00	\$0.00	\$0.00	Picklesimer Francis L&Carey E
267 232 71 00	1.00	SFD	D	1.00	1.00	\$0.00	\$0.00	Spatz Steven D
267 232 72 00	1.00	SFD	D	1.00	1.00	\$0.00	\$0.00	Rubino Anthony&Rebecca M
267 232 73 00	1.00	SFD	D	1.00	1.00	\$0.00	\$0.00	Allen Anthony L
267 232 74 00	1.00	SFD	D	1.00	1.00	\$0.00	\$0.00	Cleveland Amy K
267 232 75 00	1.00	SFD	D	1.00	1.00	\$0.00	\$0.00	Purdie Bruce C
267 232 76 00	1.00	SFD	D	1.00	1.00	\$0.00	\$0.00	Pandurangam Venkatesh B C&Canchi Kavitha
267 232 77 00	1.00	SFD	D	1.00	1.00	\$0.00	\$0.00	Ou Victor&Maria L
267 232 78 00	1.00	SFD	D	1.00	1.00	\$0.00	\$0.00	Byres David B&Toshie I
267 232 79 00	1.00	SFD	D	1.00	1.00	\$0.00	\$0.00	Cote Randa
267 232 80 00	1.00	SFD	D	1.00	1.00	\$0.00	\$0.00	Padilla Jeffrey&Christine M
267 232 81 00	1.00	SFD	D	1.00	1.00	\$0.00	\$0.00	Gangapuram Jaipal&Reddygari Sreelakshmi
267 232 82 00	1.00	SFD	D	1.00	1.00	\$0.00	\$0.00	Chung Tony&Eileen
267 232 83 00	1.00	SFD	D	1.00	1.00	\$0.00	\$0.00	Juenger Family 2015 Trust 05-28-15
267 232 84 00	1.00	SFD	D	1.00	1.00	\$0.00	\$0.00	Lee Austin&Kara
267 232 85 00	0.23	STR	D	0.00	0.00	\$0.00	\$0.00	Del Sur Community Assn
267 232 86 00	0.24	STR	D	0.00	0.00	\$0.00	\$0.00	Black Mountain Ranch L L C
267 232 87 00	0.07	STR	D	0.00	0.00	\$0.00	\$0.00	Del Sur Community Assn
267 232 88 00	0.07	STR	D	0.00	0.00	\$0.00	\$0.00	Del Sur Community Assn
267 232 89 00	0.34	STR	D	0.00	0.00	\$0.00	\$0.00	Black Mountain Ranch L L C
267 232 90 00	0.69	OSP	D	0.00	0.00	\$0.00	\$0.00	Black Mountain Ranch L L C
267 232 91 00	0.29	OSP	D	0.00	0.00	\$0.00	\$0.00	Black Mountain Ranch L L C
267 240 01 00	1.00	SFD	D	1.00	1.00	\$0.00	\$0.00	McLoughlin Trust 09-16-10
267 240 02 00	1.00	SFD	D	1.00	1.00	\$0.00	\$0.00	Miller Blake D&Jeryl A Revocable Trust 04-12-99
267 240 03 00	1.00	SFD	D	1.00	1.00	\$0.00	\$0.00	Lynn J Peter&Vitale Lisa D
267 240 04 00	1.00	SFD	D	1.00	1.00	\$0.00	\$0.00	Nguyen Hoang T&Bichvan T
267 240 05 00	1.00	SFD	D	1.00	1.00	\$0.00	\$0.00	Duck Kevin M&Jamie M
267 240 06 00	1.00	SFD	D	1.00	1.00	\$0.00	\$0.00	Pham Alexa Kim Phuong Thi
267 240 07 00	1.00	SFD	D	1.00	1.00	\$0.00	\$0.00	Covell Gretchen E S
267 240 08 00	1.00	SFD	D	1.00	1.00	\$0.00	\$0.00	Valle Vincent R&Guthrie Heather D
267 240 09 00	1.00	SFD	D	1.00	1.00	\$0.00	\$0.00	Rhoades Jason
267 240 10 00	1.00	SFD	D	1.00	1.00	\$0.00	\$0.00	Garceau Gregory S&Jennifer A
267 240 11 00	1.00	SFD	D	1.00	1.00	\$0.00	\$0.00	Lin Lisa Chia
267 240 12 00	1.00	SFD	D	1.00	1.00	\$0.00	\$0.00	Singer Living Trust 02-15-94
267 240 13 00	1.00	SFD	D	1.00	1.00	\$0.00	\$0.00	Crossland Richard&Diferdinando Dana M
267 240 14 00	1.00	SFD	D	1.00	1.00	\$0.00	\$0.00	Segal Alexander&Dina B
267 240 15 00	1.00	SFD	D	1.00	1.00	\$0.00	\$0.00	Zhu Genjiang&Gao Li
267 240 16 00	1.00	SFD	D	1.00	1.00	\$0.00	\$0.00	Feist Raymond E

EXHIBIT C - Assessment Roll (Fiscal Year 2017)
Black Mountain Ranch North Maintenance Assessment District

Parcel Number	Acres/ Units ⁽¹⁾	Land Use Code ⁽²⁾	Zone	Land Use Factor ⁽²⁾	Total EBUs	Unit Cost (\$/EUBU)	FY 2017 ⁽³⁾ Assessment	Owner Name
267 240 17 00	1.00	SFD	D	1.00	1.00	\$0.00	\$0.00	Balisky Bertha
267 240 18 00	1.00	SFD	D	1.00	1.00	\$0.00	\$0.00	Smith Franklin Dean&Catherine Ann Preciso
267 240 19 00	1.00	SFD	D	1.00	1.00	\$0.00	\$0.00	Pham Khai&Truong Tram Q
267 240 20 00	1.00	SFD	D	1.00	1.00	\$0.00	\$0.00	Wisniewski Trust 09-01-10
267 240 21 00	1.00	SFD	D	1.00	1.00	\$0.00	\$0.00	Himmelstein Family Trust 08-15-05
267 240 22 00	1.00	SFD	D	1.00	1.00	\$0.00	\$0.00	Fernandez-Lim Paz
267 240 23 00	1.00	SFD	D	1.00	1.00	\$0.00	\$0.00	Klotzkin Philip A&Jennifer L 2014 Family Trust
267 240 24 00	1.00	SFD	D	1.00	1.00	\$0.00	\$0.00	Borst Family Trust 12-10-13
267 240 25 00	1.00	SFD	D	1.00	1.00	\$0.00	\$0.00	Mccrary Ryan P&Dana S
267 240 26 00	1.00	SFD	D	1.00	1.00	\$0.00	\$0.00	Bustamante Living Trust 08-26-11
267 240 27 00	1.00	SFD	D	1.00	1.00	\$0.00	\$0.00	Kloberdanz James E&Danielle Y 2009 Trust 05-19-09
267 240 28 00	1.00	SFD	D	1.00	1.00	\$0.00	\$0.00	Sheils Brigette P
267 240 29 00	1.00	SFD	D	1.00	1.00	\$0.00	\$0.00	Hawkins David&Vidya
267 240 30 00	1.00	SFD	D	1.00	1.00	\$0.00	\$0.00	Nagaraj Sundaram&Prabhakar Aparna
267 240 31 00	1.00	SFD	D	1.00	1.00	\$0.00	\$0.00	Stainer Derek G&Laura J
267 240 32 00	1.00	SFD	D	1.00	1.00	\$0.00	\$0.00	Gilmore Lucas&Stewart Amy
267 240 33 00	1.00	SFD	D	1.00	1.00	\$0.00	\$0.00	Packer Harvey L&Cheryl A
267 240 34 00	1.00	SFD	D	1.00	1.00	\$0.00	\$0.00	Henderson Chester&Melissa
267 240 35 00	1.00	SFD	D	1.00	1.00	\$0.00	\$0.00	Vondyl Trust 02-11-04
267 240 36 00	1.00	SFD	D	1.00	1.00	\$0.00	\$0.00	Waterman Patrick B II&Janelle R
267 240 37 00	1.00	SFD	D	1.00	1.00	\$0.00	\$0.00	Mcneal Trust 04-26-10
267 240 38 00	1.00	SFD	D	1.00	1.00	\$0.00	\$0.00	Hsu Cathy 2003 Trust 06-26-03
267 240 39 00	1.00	SFD	D	1.00	1.00	\$0.00	\$0.00	Hartung Nicole A&Robert M
267 240 40 00	1.00	SFD	D	1.00	1.00	\$0.00	\$0.00	Siwabessy Randolph P&Mangindin Angelica P Revocable 2013 Tr
267 240 41 00	1.00	SFD	D	1.00	1.00	\$0.00	\$0.00	McNulty David J&Glenn-McNulty Jenny L
267 240 42 00	0.20	STR	D	0.00	0.00	\$0.00	\$0.00	Del Sur Community Assn
267 240 43 00	0.20	STR	D	0.00	0.00	\$0.00	\$0.00	Del Sur Community Assn
267 240 44 00	0.14	STR	D	0.00	0.00	\$0.00	\$0.00	Del Sur Community Assn
267 241 01 00	1.00	SFD	D	1.00	1.00	\$0.00	\$0.00	Pinderski Eric&Soukahn
267 241 02 00	1.00	SFD	D	1.00	1.00	\$0.00	\$0.00	Aquino Mona V G
267 241 03 00	1.00	SFD	D	1.00	1.00	\$0.00	\$0.00	White Roger R
267 241 04 00	1.00	SFD	D	1.00	1.00	\$0.00	\$0.00	Fullerton Timothy D&Szonn Sabine C
267 241 05 00	1.00	SFD	D	1.00	1.00	\$0.00	\$0.00	Willard Richard S
267 241 06 00	1.00	SFD	D	1.00	1.00	\$0.00	\$0.00	Schoellerman Family Trust 02-16-05
267 241 07 00	1.00	SFD	D	1.00	1.00	\$0.00	\$0.00	Stratagem Investment Group L L C
267 241 08 00	1.00	SFD	D	1.00	1.00	\$0.00	\$0.00	Mahboubi Vafa&Yount Susan L
267 241 09 00	1.00	SFD	D	1.00	1.00	\$0.00	\$0.00	Rowbottom Moorjani Trust 08-08-11
267 241 10 00	1.00	SFD	D	1.00	1.00	\$0.00	\$0.00	Avedesian Family Trust 05-19-08
267 241 11 00	1.00	SFD	D	1.00	1.00	\$0.00	\$0.00	Olson Christopher&Megan
267 241 12 00	1.00	SFD	D	1.00	1.00	\$0.00	\$0.00	Weeks Joshua&Elizabeth
267 241 13 00	1.00	SFD	D	1.00	1.00	\$0.00	\$0.00	Manuel Caridad F
267 241 14 00	1.00	SFD	D	1.00	1.00	\$0.00	\$0.00	Zhou Wei&Xi Rong
267 241 15 00	1.00	SFD	D	1.00	1.00	\$0.00	\$0.00	Vaddula Ramakoti&Rajitha
267 241 16 00	1.00	SFD	D	1.00	1.00	\$0.00	\$0.00	Alexander Scott&Debbie
267 241 17 00	1.00	SFD	D	1.00	1.00	\$0.00	\$0.00	Samiee Kevan T&Nystrom Eleanor K
267 241 18 00	1.00	SFD	D	1.00	1.00	\$0.00	\$0.00	Domingo Family Trust 12-05-05
267 241 19 00	1.00	SFD	D	1.00	1.00	\$0.00	\$0.00	Do Jason Q&Ailoon H
267 241 20 00	1.00	SFD	D	1.00	1.00	\$0.00	\$0.00	Johnson Jeralyn Delia
267 241 21 00	1.00	SFD	D	1.00	1.00	\$0.00	\$0.00	Culligan Joseph P&Kimberly A
267 241 22 00	1.00	SFD	D	1.00	1.00	\$0.00	\$0.00	Krishnamurthi Sai N&Mahalingam Aarthi
267 241 23 00	1.00	SFD	D	1.00	1.00	\$0.00	\$0.00	Hallock Samuel H&Wasserman-Hallock Lindsay C
267 241 24 00	1.00	SFD	D	1.00	1.00	\$0.00	\$0.00	Aoshima Revocable Living 2010 Trust 08-09-10
267 241 25 00	1.00	SFD	D	1.00	1.00	\$0.00	\$0.00	Shelton Jeffrey S&Quan Uyen Ngoc
267 241 26 00	1.00	SFD	D	1.00	1.00	\$0.00	\$0.00	Kim Lae-Hoon&Lee Su Na
267 241 27 00	1.00	SFD	D	1.00	1.00	\$0.00	\$0.00	Ramos Tryna M
267 241 28 00	1.00	SFD	D	1.00	1.00	\$0.00	\$0.00	Svetina Marko&Tsurska Olena A
267 241 29 00	1.00	SFD	D	1.00	1.00	\$0.00	\$0.00	Munoz Jose
267 241 30 00	1.00	SFD	D	1.00	1.00	\$0.00	\$0.00	Trytek Susan E
267 241 31 00	1.00	SFD	D	1.00	1.00	\$0.00	\$0.00	Molocznik Trust 05-13-13

EXHIBIT C - Assessment Roll (Fiscal Year 2017)
Black Mountain Ranch North Maintenance Assessment District

Parcel Number	Acres/ Units ⁽¹⁾	Land Use Code ⁽²⁾	Zone	Land Use Factor ⁽²⁾	Total EBUs	Unit Cost (\$/EUBU)	FY 2017 ⁽³⁾ Assessment	Owner Name
267 241 32 00	1.00	SFD	D	1.00	1.00	\$0.00	\$0.00	Gouvis Peter&Heather
267 241 33 00	1.00	SFD	D	1.00	1.00	\$0.00	\$0.00	Delonge Mary J Trust 11-16-02
267 241 34 00	1.00	SFD	D	1.00	1.00	\$0.00	\$0.00	Hewitt F&J Family Trust 11-21-90
267 241 35 00	1.00	SFD	D	1.00	1.00	\$0.00	\$0.00	Sundel Samuel&Martha
267 241 36 00	1.00	SFD	D	1.00	1.00	\$0.00	\$0.00	Chen Ricky Z
267 241 37 00	1.00	SFD	D	1.00	1.00	\$0.00	\$0.00	Hazlehurst Michael&Amy
267 241 38 00	1.00	SFD	D	1.00	1.00	\$0.00	\$0.00	Edrosolo Arnie J G&Rachel A F
267 241 39 00	1.00	SFD	D	1.00	1.00	\$0.00	\$0.00	Davies Kirsten A
267 241 40 00	1.00	SFD	D	1.00	1.00	\$0.00	\$0.00	Xu Zheming&Yang Yiran
267 241 41 00	1.00	SFD	D	1.00	1.00	\$0.00	\$0.00	Degradis William D&Monica
267 241 42 00	0.17	STR	D	0.00	0.00	\$0.00	\$0.00	Del Sur Community Association
267 241 43 00	0.26	STR	D	0.00	0.00	\$0.00	\$0.00	Del Sur Community Association
267 241 44 00	0.20	STR	D	0.00	0.00	\$0.00	\$0.00	Shea Homes Limited Partnership
267 250 01 00	1.00	SFD	D	1.00	1.00	\$0.00	\$0.00	Jaleel Gassan&Hasan Ranya Family Trust 11-08-07
267 250 02 00	1.00	SFD	D	1.00	1.00	\$0.00	\$0.00	Shay Raymond A&Theresa P
267 250 03 00	1.00	SFD	D	1.00	1.00	\$0.00	\$0.00	Gruen Jonathan D&Christine R
267 250 04 00	1.00	SFD	D	1.00	1.00	\$0.00	\$0.00	Orosa Dennis R&Marie G
267 250 05 00	1.00	SFD	D	1.00	1.00	\$0.00	\$0.00	Niemela Jari&Allen Carolyn J
267 250 06 00	1.00	SFD	D	1.00	1.00	\$0.00	\$0.00	Mcguire John A&Theresa M
267 250 07 00	1.00	SFD	D	1.00	1.00	\$0.00	\$0.00	Duran Rodolfo H&Mendez Ranferis Y S
267 250 08 00	1.00	SFD	D	1.00	1.00	\$0.00	\$0.00	Anaya Rashida Trust 09-01-09
267 250 09 00	1.00	SFD	D	1.00	1.00	\$0.00	\$0.00	Yuguchi Karen M
267 250 10 00	1.00	SFD	D	1.00	1.00	\$0.00	\$0.00	Koo Seongjoon&Hyon K
267 250 11 00	1.00	SFD	D	1.00	1.00	\$0.00	\$0.00	Fisher Family Trust 04-04-15
267 250 12 00	1.00	SFD	D	1.00	1.00	\$0.00	\$0.00	Calacsan Simeon V Jr
267 250 13 00	1.00	SFD	D	1.00	1.00	\$0.00	\$0.00	Shinn Katheryn P
267 250 14 00	1.00	SFD	D	1.00	1.00	\$0.00	\$0.00	Wilkes Patrick T&Philippa K
267 250 15 00	1.00	SFD	D	1.00	1.00	\$0.00	\$0.00	Hunsaker Brent G
267 250 16 00	1.00	SFD	D	1.00	1.00	\$0.00	\$0.00	Chen Shou-Hsien&Wang Hsiao-Hsuan
267 250 17 00	1.00	SFD	D	1.00	1.00	\$0.00	\$0.00	Wirtz Brian D&Alison B
267 250 18 00	1.00	SFD	D	1.00	1.00	\$0.00	\$0.00	Gray Charles L Jr&Judy A
267 250 19 00	1.00	SFD	D	1.00	1.00	\$0.00	\$0.00	Chinn Kevin E&Kendall L
267 250 20 00	1.00	SFD	D	1.00	1.00	\$0.00	\$0.00	Morse Revocable Living Trust 06-12-91
267 250 21 00	1.00	SFD	D	1.00	1.00	\$0.00	\$0.00	Hasbrook Daniel G&Patricia A
267 250 22 00	1.00	SFD	D	1.00	1.00	\$0.00	\$0.00	Riley Michael K&Faucher Heather C
267 250 23 00	1.00	SFD	D	1.00	1.00	\$0.00	\$0.00	Sanders Sean H&Christina A
267 250 24 00	1.00	SFD	D	1.00	1.00	\$0.00	\$0.00	Smith Christopher E&Sandra P Escalante
267 250 25 00	1.00	SFD	D	1.00	1.00	\$0.00	\$0.00	Riggins Family Trust 04-09-09
267 250 26 00	1.00	SFD	D	1.00	1.00	\$0.00	\$0.00	Chung Hyukjune&Hwang Jungshim
267 250 27 00	1.00	SFD	D	1.00	1.00	\$0.00	\$0.00	Peterson Kevin&Francine
267 250 28 00	1.00	SFD	D	1.00	1.00	\$0.00	\$0.00	Sherr Karin K
267 250 29 00	1.00	SFD	D	1.00	1.00	\$0.00	\$0.00	Samhat Imad&Dika Malak E
267 250 30 00	0.02	OSP	D	0.00	0.00	\$0.00	\$0.00	Delsur Community Association
267 250 31 00	1.55	PKU	D	0.50	0.78	\$0.00	\$0.00	Del Sur Community Assn
267 270 08 00	204.00	MFR	F	0.70	142.80	\$0.00	\$0.00	C I C Fairbanks L P
267 270 10 00	6.33	OSP	F	0.00	0.00	\$0.00	\$0.00	Black Mountain Ranch L L C
267 270 10 00	3.77	OSP	G	0.00	0.00	\$0.00	\$0.00	Black Mountain Ranch L L C
267 270 11 00	1.50	UTL	A	3.00	4.50	\$0.00	\$0.00	San Diego Gas&Electric Co
267 270 12 00	1.20	UTL	A	3.00	3.60	\$0.00	\$0.00	San Diego Gas&Electric Co
267 270 13 00	1.50	STR	A	0.00	0.00	\$0.00	\$0.00	Black Mountain Ranch L L C
267 280 01 00	1.00	SFD	D	1.00	1.00	\$0.00	\$0.00	Schaller A&J Family Trust 12-06-13
267 280 02 00	1.00	SFD	D	1.00	1.00	\$0.00	\$0.00	Bomar Steven&Lisa
267 280 03 00	1.00	SFD	D	1.00	1.00	\$0.00	\$0.00	Lowenthal&Tanimoto Family Trust 3 04-03-06
267 280 04 00	1.00	SFD	D	1.00	1.00	\$0.00	\$0.00	Gagne Gary R&Ramos Blanca S
267 280 05 00	1.00	SFD	D	1.00	1.00	\$0.00	\$0.00	J J S C L M Revocable Trust 02-22-08
267 280 06 00	1.00	SFD	D	1.00	1.00	\$0.00	\$0.00	Naval Joseph N&Gonzales-Naval Laarni E
267 280 07 00	1.00	SFD	D	1.00	1.00	\$0.00	\$0.00	Hill Bryan S&Nicole
267 280 08 00	1.00	SFD	D	1.00	1.00	\$0.00	\$0.00	Benavidez Arturo&Adela
267 280 09 00	1.00	SFD	D	1.00	1.00	\$0.00	\$0.00	Loucks Family Trust 06-24-98

EXHIBIT C - Assessment Roll (Fiscal Year 2017)
Black Mountain Ranch North Maintenance Assessment District

Parcel Number	Acres/ Units ⁽¹⁾	Land Use Code ⁽²⁾	Zone	Land Use Factor ⁽²⁾	Total EBUs	Unit Cost (\$/EUBU)	FY 2017 ⁽³⁾ Assessment	Owner Name
267 280 10 00	1.00	SFD	D	1.00	1.00	\$0.00	\$0.00	Homolac Steven J&Gordon Carolyn L
267 280 11 00	1.00	SFD	D	1.00	1.00	\$0.00	\$0.00	Villanueva Lily M C
267 280 12 00	1.00	SFD	D	1.00	1.00	\$0.00	\$0.00	Lapine Ryan&Samantha
267 280 13 00	1.00	SFD	D	1.00	1.00	\$0.00	\$0.00	Vaplon Craig M&Leah M
267 280 14 00	1.00	SFD	D	1.00	1.00	\$0.00	\$0.00	Murken Revocable Living Trust 05-11-09
267 280 15 00	1.00	SFD	D	1.00	1.00	\$0.00	\$0.00	Markowicz-Sinopoli Trust 12-16-09
267 280 16 00	1.00	SFD	D	1.00	1.00	\$0.00	\$0.00	Miller Jeffrey A&Erin L
267 280 17 00	1.00	SFD	D	1.00	1.00	\$0.00	\$0.00	Peace James C&Heidi A
267 280 18 00	1.00	SFD	D	1.00	1.00	\$0.00	\$0.00	Alahmad Mohamad
267 280 19 00	1.00	SFD	D	1.00	1.00	\$0.00	\$0.00	Parathasarathy Muralikrishnan&Mohan Sweatha
267 280 20 00	1.00	SFD	D	1.00	1.00	\$0.00	\$0.00	Morales Emil D&Jody A
267 280 21 00	1.00	SFD	D	1.00	1.00	\$0.00	\$0.00	Jereza Living Trust 12-03-02
267 280 22 00	1.00	SFD	D	1.00	1.00	\$0.00	\$0.00	Kaileh Tanya 2014 Trust
267 280 23 00	1.00	SFD	D	1.00	1.00	\$0.00	\$0.00	Valero Eric D&Eileen L
267 280 24 00	1.00	SFD	D	1.00	1.00	\$0.00	\$0.00	Banaga Romulo E&Marita
267 280 25 00	1.00	SFD	D	1.00	1.00	\$0.00	\$0.00	Salimi Nima&Ramadev Misha
267 280 26 00	1.00	SFD	D	1.00	1.00	\$0.00	\$0.00	Llamas Richard D&Janet S
267 280 27 00	1.00	SFD	D	1.00	1.00	\$0.00	\$0.00	Davis Dana
267 280 28 00	1.00	SFD	D	1.00	1.00	\$0.00	\$0.00	Slavin Leonid&Marina O
267 280 29 00	1.00	SFD	D	1.00	1.00	\$0.00	\$0.00	Petray James C&Andrea L
267 280 30 00	1.00	SFD	D	1.00	1.00	\$0.00	\$0.00	Gonzales Pelagio B&Lorna E Revocable 2013 Trust
267 280 31 00	1.00	SFD	D	1.00	1.00	\$0.00	\$0.00	Camaciang Jonathan T&Lisa E
267 280 32 00	0.19	STR	D	0.00	0.00	\$0.00	\$0.00	Del Sur Community Assn
267 281 01 00	1.00	SFD	D	1.00	1.00	\$0.00	\$0.00	Atkinson Matthew&Saba Julia
267 281 02 00	1.00	SFD	D	1.00	1.00	\$0.00	\$0.00	Feldman James A&Leslie M
267 281 03 00	1.00	SFD	D	1.00	1.00	\$0.00	\$0.00	Small Wendell T&Kristen L
267 281 04 00	1.00	SFD	D	1.00	1.00	\$0.00	\$0.00	Stewart Family Trust 05-05-11
267 281 05 00	1.00	SFD	D	1.00	1.00	\$0.00	\$0.00	Campbell Family Revocable Trust 09-29-15
267 281 06 00	1.00	SFD	D	1.00	1.00	\$0.00	\$0.00	Petersen R J&Yasmine A
267 281 07 00	1.00	SFD	D	1.00	1.00	\$0.00	\$0.00	Delatorre Living Trust 04-27-11
267 281 08 00	1.00	SFD	D	1.00	1.00	\$0.00	\$0.00	Borgardt Brandon S&Elizabeth A
267 281 09 00	1.00	SFD	D	1.00	1.00	\$0.00	\$0.00	Tran Kristin H&Bach Binh
267 281 10 00	1.00	SFD	D	1.00	1.00	\$0.00	\$0.00	Bustos Jeffrey B&Lajoie Andrea
267 281 11 00	1.00	SFD	D	1.00	1.00	\$0.00	\$0.00	Hernandez Johnny R&Susie S
267 281 12 00	1.00	SFD	D	1.00	1.00	\$0.00	\$0.00	Poulsen Todd W&Marilyn C
267 281 13 00	1.00	SFD	D	1.00	1.00	\$0.00	\$0.00	Hayman Danielle K
267 281 14 00	1.00	SFD	D	1.00	1.00	\$0.00	\$0.00	Thirumala Raghavan&Karthikeyan Deepa
267 281 15 00	1.00	SFD	D	1.00	1.00	\$0.00	\$0.00	Fajardo Ceferino T Iii&Garcia Mary A
267 281 16 00	1.00	SFD	D	1.00	1.00	\$0.00	\$0.00	Law Robert H Jr&Mujaji D
267 281 17 00	1.00	SFD	D	1.00	1.00	\$0.00	\$0.00	Bhalla Anurag&Shuchi
267 281 18 00	1.00	SFD	D	1.00	1.00	\$0.00	\$0.00	Roberts Janene L
267 281 19 00	1.00	SFD	D	1.00	1.00	\$0.00	\$0.00	Glaser Thomas&Diana
267 281 20 00	1.00	SFD	D	1.00	1.00	\$0.00	\$0.00	Johnson Family Trust 09-01-05
267 281 21 00	1.00	SFD	D	1.00	1.00	\$0.00	\$0.00	Shah Asif I
267 281 22 00	1.00	SFD	D	1.00	1.00	\$0.00	\$0.00	Sullaway Britta
267 281 23 00	1.00	SFD	D	1.00	1.00	\$0.00	\$0.00	Singh Mary T
267 281 24 00	1.00	SFD	D	1.00	1.00	\$0.00	\$0.00	Dessert Robert L&Julie A
267 281 25 00	1.00	SFD	D	1.00	1.00	\$0.00	\$0.00	Tholtempudi Krishna P&Paladugu Rama S
267 281 26 00	1.00	SFD	D	1.00	1.00	\$0.00	\$0.00	Vandeberg Jerry S&Deborah R Revocable Trust 11-18-10
267 281 27 00	1.00	SFD	D	1.00	1.00	\$0.00	\$0.00	Katragadda Siddhartha&Kancherla Keerthi
267 281 28 00	1.00	SFD	D	1.00	1.00	\$0.00	\$0.00	Packer Michael G&Lynda E
267 281 29 00	1.00	SFD	D	1.00	1.00	\$0.00	\$0.00	Choy Martin&Julie
267 281 30 00	1.00	SFD	D	1.00	1.00	\$0.00	\$0.00	Reissman Family Trust 11-18-08
267 281 31 00	1.00	SFD	D	1.00	1.00	\$0.00	\$0.00	Ghorashi Bijan
267 281 32 00	1.00	SFD	D	1.00	1.00	\$0.00	\$0.00	Costa Family Trust 09-29-99
267 281 33 00	1.00	SFD	D	1.00	1.00	\$0.00	\$0.00	Griffin Christian T&Dominique M
267 281 34 00	1.00	SFD	D	1.00	1.00	\$0.00	\$0.00	Berman 2014 Family Trust
267 281 35 00	1.00	SFD	D	1.00	1.00	\$0.00	\$0.00	Dendinger Michael T
267 281 36 00	1.00	SFD	D	1.00	1.00	\$0.00	\$0.00	Avaregan Ashley A&Ruslana

EXHIBIT C - Assessment Roll (Fiscal Year 2017)
Black Mountain Ranch North Maintenance Assessment District

Parcel Number	Acres/ Units ⁽¹⁾	Land Use Code ⁽²⁾	Zone	Land Use Factor ⁽²⁾	Total EBUs	Unit Cost (\$/EUBU)	FY 2017 ⁽³⁾ Assessment	Owner Name
267 281 37 00	1.00	SFD	D	1.00	1.00	\$0.00	\$0.00	Chan Howard&Elizabeth D G Family 2014 Trust
267 281 38 00	0.22	STR	D	0.00	0.00	\$0.00	\$0.00	Del Sur Community Assn
267 281 39 00	0.06	STR	D	0.00	0.00	\$0.00	\$0.00	Del Sur Community Association
267 281 40 00	0.06	STR	D	0.00	0.00	\$0.00	\$0.00	Del Sur Community Association
267 281 41 00	1.45	PKU	D	0.50	0.73	\$0.00	\$0.00	Del Sur Community Assn
267 290 01 00	1.00	SFD	D	1.00	1.00	\$0.00	\$0.00	Wooden Edward&Sarah
267 290 02 00	1.00	SFD	D	1.00	1.00	\$0.00	\$0.00	Rosenfeld Jason L&Ilyse H
267 290 03 00	1.00	SFD	D	1.00	1.00	\$0.00	\$0.00	Kihara James K&Christian M
267 290 04 00	1.00	SFD	D	1.00	1.00	\$0.00	\$0.00	Smith Thomas&Rory
267 290 05 00	1.00	SFD	D	1.00	1.00	\$0.00	\$0.00	Chiovari Family 2014 Trust 11-21-14
267 290 06 00	1.00	SFD	D	1.00	1.00	\$0.00	\$0.00	Bertrand Cynthia J
267 290 07 00	1.00	SFD	D	1.00	1.00	\$0.00	\$0.00	Pollak Brett&Stephanie J
267 290 08 00	1.00	SFD	D	1.00	1.00	\$0.00	\$0.00	Crowell Jason&Cynthia
267 290 09 00	1.00	SFD	D	1.00	1.00	\$0.00	\$0.00	Kunowski Peter&Betty
267 290 10 00	1.00	SFD	D	1.00	1.00	\$0.00	\$0.00	Leedom Michael&Jennifer
267 290 11 00	1.00	SFD	D	1.00	1.00	\$0.00	\$0.00	Cottle David&Jennifer
267 290 12 00	1.00	SFD	D	1.00	1.00	\$0.00	\$0.00	Brogdon James M&Donovan Maria
267 290 13 00	1.00	SFD	D	1.00	1.00	\$0.00	\$0.00	Roland Jason&Smith Deborah
267 290 14 00	1.00	SFD	D	1.00	1.00	\$0.00	\$0.00	Sadrieh Kiana
267 290 15 00	1.00	SFD	D	1.00	1.00	\$0.00	\$0.00	Han Sangdon&Kim Hyeju
267 290 16 00	1.00	SFD	D	1.00	1.00	\$0.00	\$0.00	Bhaghani Family 2008 Trust 05-29-08&Jamal Altaf A&Amna Z Et /
267 290 17 00	1.00	SFD	D	1.00	1.00	\$0.00	\$0.00	Mccartin Thomas W
267 290 18 00	1.00	SFD	D	1.00	1.00	\$0.00	\$0.00	Galliani Anthony&Paola
267 290 19 00	1.00	SFD	D	1.00	1.00	\$0.00	\$0.00	Fox Danny
267 290 20 00	1.00	SFD	D	1.00	1.00	\$0.00	\$0.00	Berkebile James W&Amy G
267 290 21 00	1.00	SFD	D	1.00	1.00	\$0.00	\$0.00	Krylow John P Jr&Tara M
267 290 22 00	1.00	SFD	D	1.00	1.00	\$0.00	\$0.00	Kahn Carl
267 290 23 00	1.00	SFD	D	1.00	1.00	\$0.00	\$0.00	Felke Family Trust 02-27-15
267 290 24 00	1.00	SFD	D	1.00	1.00	\$0.00	\$0.00	Rowe Alan&Petra
267 290 25 00	1.00	SFD	D	1.00	1.00	\$0.00	\$0.00	Forshan Dana&Collette
267 290 26 00	1.00	SFD	D	1.00	1.00	\$0.00	\$0.00	Dornan Stephen R&Kim A
267 290 27 00	1.00	SFD	D	1.00	1.00	\$0.00	\$0.00	Lewandowski Ray
267 290 28 00	1.00	SFD	D	1.00	1.00	\$0.00	\$0.00	Isaacson Kelly
267 290 29 00	1.00	SFD	D	1.00	1.00	\$0.00	\$0.00	Taylor Theodore M&Nord-Taylor Tamera
267 290 30 00	1.00	SFD	D	1.00	1.00	\$0.00	\$0.00	Andrade Adam&May M
267 290 31 00	1.00	SFD	D	1.00	1.00	\$0.00	\$0.00	Modeste Roger T&Laverne
267 290 32 00	1.00	SFD	D	1.00	1.00	\$0.00	\$0.00	Vandling Michael G&Marla J
267 290 33 00	1.00	SFD	D	1.00	1.00	\$0.00	\$0.00	L L T F Revocable Trust 09-19-10
267 290 34 00	1.00	SFD	D	1.00	1.00	\$0.00	\$0.00	Glass John T&Julie D
267 290 35 00	1.00	SFD	D	1.00	1.00	\$0.00	\$0.00	Teeter Matthew&Jennifer Trust 05-30-13
267 290 36 00	1.00	SFD	D	1.00	1.00	\$0.00	\$0.00	Pascua Ricardo&Jesiefin
267 290 37 00	1.00	SFD	D	1.00	1.00	\$0.00	\$0.00	Shabbak Mohammad H&Morshedian Sonia Joint Living Trust 11-2
267 290 38 00	1.00	SFD	D	1.00	1.00	\$0.00	\$0.00	Christian Richard&Jennifer
267 290 39 00	1.00	SFD	D	1.00	1.00	\$0.00	\$0.00	Rice James&Christine
267 290 40 00	1.00	SFD	D	1.00	1.00	\$0.00	\$0.00	Knight Bryan M&Laura E
267 290 41 00	1.00	SFD	D	1.00	1.00	\$0.00	\$0.00	Hickman Lisa
267 290 42 00	1.00	SFD	D	1.00	1.00	\$0.00	\$0.00	Bautista Anthony J&Alfonso-Bautista Joycelyn P
267 290 43 00	1.00	SFD	D	1.00	1.00	\$0.00	\$0.00	Jackman Keith&Annie
267 290 44 00	1.00	SFD	D	1.00	1.00	\$0.00	\$0.00	Margro Michael T&Susan L
267 290 45 00	1.00	SFD	D	1.00	1.00	\$0.00	\$0.00	Fierro Alfonso Jr&Caroline V
267 290 46 00	1.00	SFD	D	1.00	1.00	\$0.00	\$0.00	Bailey Cristina G
267 290 47 00	1.00	SFD	D	1.00	1.00	\$0.00	\$0.00	Maliyappanahalli Shiva K&Mahajan Harshada
267 290 48 00	1.00	SFD	D	1.00	1.00	\$0.00	\$0.00	Ioannou Nikolaos&Lara D
267 290 49 00	1.00	SFD	D	1.00	1.00	\$0.00	\$0.00	Leychkis David&Olga
267 290 50 00	1.00	SFD	D	1.00	1.00	\$0.00	\$0.00	Cabezuela Family Trust 07-03-12
267 290 51 00	1.00	SFD	D	1.00	1.00	\$0.00	\$0.00	Le Phong The&Vuong Ashley My
267 290 52 00	1.00	SFD	D	1.00	1.00	\$0.00	\$0.00	Boyce Mark&Kiran P
267 290 53 00	0.02	OSP	D	0.00	0.00	\$0.00	\$0.00	Del Sur Community Assn
267 290 54 00	0.03	OSP	D	0.00	0.00	\$0.00	\$0.00	Del Sur Community Assn

EXHIBIT C - Assessment Roll (Fiscal Year 2017)
Black Mountain Ranch North Maintenance Assessment District

Parcel Number	Acres/ Units ⁽¹⁾	Land Use Code ⁽²⁾	Zone	Land Use Factor ⁽²⁾	Total EBUs	Unit Cost (\$/EUBU)	FY 2017 ⁽³⁾ Assessment	Owner Name
267 300 01 00	1.00	SFD	B	1.00	1.00	\$0.00	\$0.00	Black Mountain Ranch L L C
267 300 02 00	1.00	SFD	B	1.00	1.00	\$0.00	\$0.00	Black Mountain Ranch L L C
267 300 03 00	1.00	SFD	B	1.00	1.00	\$0.00	\$0.00	Black Mountain Ranch L L C
267 300 04 00	1.00	SFD	B	1.00	1.00	\$0.00	\$0.00	Black Mountain Ranch L L C
267 300 05 00	1.00	SFD	B	1.00	1.00	\$0.00	\$0.00	Black Mountain Ranch L L C
267 300 06 00	1.00	SFD	B	1.00	1.00	\$0.00	\$0.00	Black Mountain Ranch L L C
267 300 07 00	1.00	SFD	B	1.00	1.00	\$0.00	\$0.00	Black Mountain Ranch L L C
267 300 08 00	1.00	SFD	B	1.00	1.00	\$0.00	\$0.00	Black Mountain Ranch L L C
267 300 09 00	1.00	SFD	B	1.00	1.00	\$0.00	\$0.00	Black Mountain Ranch L L C
267 300 10 00	1.00	SFD	B	1.00	1.00	\$0.00	\$0.00	Black Mountain Ranch L L C
267 300 11 00	1.00	SFD	B	1.00	1.00	\$0.00	\$0.00	Black Mountain Ranch L L C
267 300 12 00	1.00	SFD	B	1.00	1.00	\$0.00	\$0.00	Black Mountain Ranch L L C
267 300 13 00	0.49	OSP	B	0.00	0.00	\$0.00	\$0.00	Black Mountain Ranch L L C
267 300 14 00	0.33	OSP	B	0.00	0.00	\$0.00	\$0.00	Black Mountain Ranch L L C
267 300 15 00	0.94	OSP	B	0.00	0.00	\$0.00	\$0.00	Black Mountain Ranch L L C
267 300 16 00	0.69	OSP	B	0.00	0.00	\$0.00	\$0.00	Black Mountain Ranch L L C
267 300 17 00	4.67	OSP	B	0.00	0.00	\$0.00	\$0.00	Black Mountain Ranch L L C
267 310 01 00	1.00	SFD	A	1.00	1.00	\$0.00	\$0.00	Sheffres Robert A&Karen M
267 310 02 00	1.00	SFD	A	1.00	1.00	\$0.00	\$0.00	Lamm Revocable Trust 10-13-99
267 310 03 00	1.00	SFD	A	1.00	1.00	\$0.00	\$0.00	Weintraub Richard A&Miller Lisa A
267 310 04 00	1.00	SFD	A	1.00	1.00	\$0.00	\$0.00	Foster Toni D&Pugh P Renee
267 310 05 00	1.00	SFD	A	1.00	1.00	\$0.00	\$0.00	Roche Timothy G&Lori M
267 310 06 00	1.00	SFD	A	1.00	1.00	\$0.00	\$0.00	Braunstein Roman&Polina
267 310 07 00	1.00	SFD	A	1.00	1.00	\$0.00	\$0.00	Ghazi Hamid&Babakhani Fariba K
267 310 08 00	1.00	SFD	A	1.00	1.00	\$0.00	\$0.00	Maas Fredric J
267 310 09 00	1.00	SFD	A	1.00	1.00	\$0.00	\$0.00	Borgardt S&S Family Trust 08-22-07
267 310 10 00	1.00	SFD	A	1.00	1.00	\$0.00	\$0.00	Lindsey Family Trust 09-18-02
267 310 11 00	1.00	SFD	A	1.00	1.00	\$0.00	\$0.00	Patel Piyush M&Sandhya P
267 310 12 00	1.00	SFD	A	1.00	1.00	\$0.00	\$0.00	Feidelberg-Codini Family Trust 04-15-03
267 310 13 00	1.00	SFD	A	1.00	1.00	\$0.00	\$0.00	Fujii Roger U Trust 03-12-07
267 310 14 00	1.00	SFD	A	1.00	1.00	\$0.00	\$0.00	Taylor Elizabeth L
267 310 15 00	1.00	SFD	A	1.00	1.00	\$0.00	\$0.00	Lane Nathaniel I&Hamilton Lynsey R
267 310 16 00	1.00	SFD	A	1.00	1.00	\$0.00	\$0.00	Lin Yung-Chen&Sue-Jen Fu
267 310 17 00	1.00	SFD	A	1.00	1.00	\$0.00	\$0.00	Diggs Gregory S&Nichola M
267 310 18 00	1.00	SFD	A	1.00	1.00	\$0.00	\$0.00	Nabai Sarah Living Trust 05-29-03
267 310 19 00	1.00	SFD	A	1.00	1.00	\$0.00	\$0.00	Zupnik Jonathan&Kim
267 310 20 00	1.00	SFD	A	1.00	1.00	\$0.00	\$0.00	Espinosa Edmund&Brooke
267 310 21 00	4.85	OSP	A	0.00	0.00	\$0.00	\$0.00	Black Mountain Ranch L L C
267 310 22 00	0.53	OSP	A	0.00	0.00	\$0.00	\$0.00	Black Mountain Ranch L L C
267 310 23 00	1.14	STR	A	0.00	0.00	\$0.00	\$0.00	Avaron Community Assn
267 310 24 00	0.38	STR	A	0.00	0.00	\$0.00	\$0.00	Avaron Community Assn
267 310 25 00	0.87	STR	A	0.00	0.00	\$0.00	\$0.00	Black Mountain Ranch L L C
267 310 26 00	0.05	STR	A	0.00	0.00	\$0.00	\$0.00	Black Mountain Ranch L L C
267 311 01 00	1.00	SFD	A	1.00	1.00	\$0.00	\$0.00	Doustdar Family Trust 03-14-05
267 311 02 00	1.00	SFD	A	1.00	1.00	\$0.00	\$0.00	Hsu Tony&Jennifer L Revocable Trust 08-14-06
267 311 03 00	1.00	SFD	A	1.00	1.00	\$0.00	\$0.00	Weeks Chandler&Katrina
267 311 04 00	1.00	SFD	A	1.00	1.00	\$0.00	\$0.00	Spittler Family Trust 11-20-01
267 311 05 00	1.00	SFD	A	1.00	1.00	\$0.00	\$0.00	Bindra Sarvjeet S&Simrat K
267 311 06 00	1.00	SFD	A	1.00	1.00	\$0.00	\$0.00	Cambria Trust 06-01-11
267 311 07 00	1.00	SFD	A	1.00	1.00	\$0.00	\$0.00	Vandenberg Brockton G&Amy
267 311 08 00	1.00	SFD	A	1.00	1.00	\$0.00	\$0.00	Vasbinder Joshua D&Courtney M
267 311 09 00	1.00	SFD	A	1.00	1.00	\$0.00	\$0.00	Katz Family Trust 07-24-01
267 311 10 00	1.00	SFD	A	1.00	1.00	\$0.00	\$0.00	Lohmann Family Trust 03-30-06
267 311 11 00	1.00	SFD	A	1.00	1.00	\$0.00	\$0.00	Link Matthew W&Tiffany S
267 311 12 00	1.00	SFD	A	1.00	1.00	\$0.00	\$0.00	Fisher Family Trust 03-01-06
267 311 13 00	1.00	SFD	A	1.00	1.00	\$0.00	\$0.00	Magbanua Robert&Jennifer G
267 311 14 00	1.00	SFD	A	1.00	1.00	\$0.00	\$0.00	Hollander Dean&Jennifer
267 311 15 00	1.00	SFD	A	1.00	1.00	\$0.00	\$0.00	Shooter A&M Trust 12-05-06
267 311 16 00	1.00	SFD	A	1.00	1.00	\$0.00	\$0.00	Harris Timothy J&Altevers Aimee S Trust 06-22-05

EXHIBIT C - Assessment Roll (Fiscal Year 2017)
Black Mountain Ranch North Maintenance Assessment District

Parcel Number	Acres/ Units ⁽¹⁾	Land Use Code ⁽²⁾	Zone	Land Use Factor ⁽²⁾	Total EBUs	Unit Cost (\$/EUBU)	FY 2017 ⁽³⁾ Assessment	Owner Name
267 311 17 00	1.00	SFD	A	1.00	1.00	\$0.00	\$0.00	Jarrett Family Trust 02-11-15
267 311 18 00	1.00	SFD	A	1.00	1.00	\$0.00	\$0.00	Johnston Niall F&Farnham Jennifer L
267 311 19 00	1.00	SFD	A	1.00	1.00	\$0.00	\$0.00	Franke Christopher
267 311 20 00	1.00	SFD	A	1.00	1.00	\$0.00	\$0.00	Youngren Ronald G&Regina M Joint Living Trust 01-19-05
267 311 21 00	1.00	SFD	A	1.00	1.00	\$0.00	\$0.00	Macdonald Michelle G Revocable Trust 04-08-08
267 311 22 00	1.00	SFD	A	1.00	1.00	\$0.00	\$0.00	Lam Tuan Hai
267 311 23 00	1.00	SFD	A	1.00	1.00	\$0.00	\$0.00	Cummins Bharne Family Trust 04-11-15
267 311 24 00	1.00	SFD	A	1.00	1.00	\$0.00	\$0.00	Isaacson Blake Revocable Living Trust 11-01-97
267 311 25 00	1.00	SFD	A	1.00	1.00	\$0.00	\$0.00	Samuel Living Trust 06-08-13
267 311 26 00	0.33	OSP	A	0.00	0.00	\$0.00	\$0.00	Avaron Community Association
267 311 27 00	0.83	STR	A	0.00	0.00	\$0.00	\$0.00	Avaron Community Association
267 311 28 00	0.70	STR	A	0.00	0.00	\$0.00	\$0.00	Avaron Community Assn
267 311 29 00	2.42	STR	A	0.00	0.00	\$0.00	\$0.00	Black Mountain Ranch L L C
267 312 01 00	1.00	SFD	A	1.00	1.00	\$0.00	\$0.00	Happy To Be Family Trust 05-21-11
267 312 02 00	1.00	SFD	A	1.00	1.00	\$0.00	\$0.00	Yasotorn Amy S
267 312 03 00	1.00	SFD	A	1.00	1.00	\$0.00	\$0.00	Ratray Jason&Kristina M
267 312 04 00	1.00	SFD	A	1.00	1.00	\$0.00	\$0.00	Howell James M&Pamela B
267 312 05 00	1.00	SFD	A	1.00	1.00	\$0.00	\$0.00	Labarbera N C D Irevocable 2010 Trust 11-10-10
267 312 06 00	1.00	SFD	A	1.00	1.00	\$0.00	\$0.00	Guerra Family Trust 12-17-13
267 312 07 00	1.00	SFD	A	1.00	1.00	\$0.00	\$0.00	Eisenberg Steven G&Julie S
267 312 08 00	1.00	SFD	A	1.00	1.00	\$0.00	\$0.00	Ghai Rajinder S&Mandeep K
267 312 09 00	1.00	SFD	A	1.00	1.00	\$0.00	\$0.00	Leone Living Trust 12-31-96
267 312 10 00	1.00	SFD	A	1.00	1.00	\$0.00	\$0.00	Jehan Qaiser
267 312 11 00	1.00	SFD	A	1.00	1.00	\$0.00	\$0.00	Gaeir Aaron&Kimberley
267 312 12 00	1.00	SFD	A	1.00	1.00	\$0.00	\$0.00	Hammonds Family Trust 07-23-14
267 312 13 00	1.00	SFD	A	1.00	1.00	\$0.00	\$0.00	Herrera Family Trust 11-02-09
267 312 14 00	1.00	SFD	A	1.00	1.00	\$0.00	\$0.00	Helm John&Mary Family Trust 01-25-10
267 312 15 00	0.18	OSP	A	0.00	0.00	\$0.00	\$0.00	Avaron Community Assn
267 312 16 00	0.79	STR	A	0.00	0.00	\$0.00	\$0.00	Avaron Community Assn
267 313 02 00	1.34	OSP	A	0.00	0.00	\$0.00	\$0.00	Black Mountain Ranch L L C
267 313 03 00	0.69	OSP	A	0.00	0.00	\$0.00	\$0.00	Black Mountain Ranch L L C
267 313 04 00	0.21	OSP	A	0.00	0.00	\$0.00	\$0.00	Olivenhain Municipal Water Dist
267 313 05 00	0.23	OSP	A	0.00	0.00	\$0.00	\$0.00	Olivenhain Municipal Water Dist
267 313 06 00	0.11	OSP	A	0.00	0.00	\$0.00	\$0.00	Olivenhain Municipal Water District
267 313 07 00	0.03	OSP	A	0.00	0.00	\$0.00	\$0.00	Olivenhain Municipal Water District
267 313 08 00	18.81	OSP	A	0.00	0.00	\$0.00	\$0.00	Black Mountain Ranch L L C
267 320 01 00	1.00	SFD	D	1.00	1.00	\$0.00	\$0.00	Wheeler David D&Wendy E
267 320 02 00	1.00	SFD	D	1.00	1.00	\$0.00	\$0.00	Cate Family Trust 05-29-15
267 320 03 00	1.00	SFD	D	1.00	1.00	\$0.00	\$0.00	Bosco Karen S
267 320 04 00	1.00	SFD	D	1.00	1.00	\$0.00	\$0.00	Vandenberg Brockton G&Amy D
267 320 05 00	1.00	SFD	D	1.00	1.00	\$0.00	\$0.00	Corleto Family Trust 05-24-13
267 320 06 00	1.00	SFD	D	1.00	1.00	\$0.00	\$0.00	Tollack Toby&Cortez-Tollack Kathryn
267 320 07 00	1.00	SFD	D	1.00	1.00	\$0.00	\$0.00	Schramm Family Trust 12-05-14
267 320 08 00	1.00	SFD	D	1.00	1.00	\$0.00	\$0.00	Pederson Erik&Mashburn-Pederson Adria L
267 320 09 00	1.00	SFD	D	1.00	1.00	\$0.00	\$0.00	Wightlin Matthew&Corrine
267 320 10 01	1.00	SFD	D	1.00	1.00	\$0.00	\$0.00	Thota Kiran K&Velagaleti Swetha
267 320 10 02	1.00	SFD	D	1.00	1.00	\$0.00	\$0.00	Bismark Ronald R&Deanna L
267 320 11 01	1.00	SFD	D	1.00	1.00	\$0.00	\$0.00	Sanders Dave
267 320 11 02	1.00	SFD	D	1.00	1.00	\$0.00	\$0.00	Mckenna John R&Karissa L
267 320 12 01	1.00	SFD	D	1.00	1.00	\$0.00	\$0.00	Gundawar Manoj&Pallavi
267 320 12 02	1.00	SFD	D	1.00	1.00	\$0.00	\$0.00	Giustiniano Cheryl
267 320 13 01	1.00	SFD	D	1.00	1.00	\$0.00	\$0.00	Tarplee Todd&Allison
267 320 13 02	1.00	SFD	D	1.00	1.00	\$0.00	\$0.00	Tarplee Family Trust 06-01-00
267 320 14 01	1.00	SFD	D	1.00	1.00	\$0.00	\$0.00	Clement Pamela F Trust 06-09-89
267 320 14 02	1.00	SFD	D	1.00	1.00	\$0.00	\$0.00	Abramson Joseph G&Laure-Abramson Dinna A
267 320 15 01	1.00	SFD	D	1.00	1.00	\$0.00	\$0.00	Hundley John M&Lisa M
267 320 15 02	1.00	SFD	D	1.00	1.00	\$0.00	\$0.00	Quashnock Joseph
267 320 16 00	0.28	STR	D	0.00	0.00	\$0.00	\$0.00	Del Sur Community Assn
267 321 07 00	1.00	SFD	D	1.00	1.00	\$0.00	\$0.00	Israwi Ramsey S&Lauren J

EXHIBIT C - Assessment Roll (Fiscal Year 2017)
Black Mountain Ranch North Maintenance Assessment District

Parcel Number	Acres/ Units ⁽¹⁾	Land Use Code ⁽²⁾	Zone	Land Use Factor ⁽²⁾	Total EBUs	Unit Cost (\$/Ebu)	FY 2017 ⁽³⁾ Assessment	Owner Name
267 321 08 00	1.00	SFD	D	1.00	1.00	\$0.00	\$0.00	Kulkarni Rajeev&Nadager Deepa
267 321 09 00	1.00	SFD	D	1.00	1.00	\$0.00	\$0.00	Reinhart Trust 11-06-12
267 321 10 00	1.00	SFD	D	1.00	1.00	\$0.00	\$0.00	Barrow Daniel R&Michele M
267 321 11 00	1.00	SFD	D	1.00	1.00	\$0.00	\$0.00	Weil Karen Revocable Trust 06-19-14
267 321 12 00	1.00	SFD	D	1.00	1.00	\$0.00	\$0.00	Hamui K T Family Trust 05-20-13
267 321 13 00	1.00	SFD	D	1.00	1.00	\$0.00	\$0.00	Caulum Family Living Trust 03-28-03
267 321 14 00	1.00	SFD	D	1.00	1.00	\$0.00	\$0.00	Kirsten Nico&Cornelia J
267 321 15 00	0.24	STR	D	0.00	0.00	\$0.00	\$0.00	Standard Pacific Corp
267 321 16 01	1.00	SFD	D	1.00	1.00	\$0.00	\$0.00	Yu Hokyoung&Kwon Na Yeong
267 321 16 02	1.00	SFD	D	1.00	1.00	\$0.00	\$0.00	Petersen Mark A&Sara R
267 321 16 03	1.00	SFD	D	1.00	1.00	\$0.00	\$0.00	Marcum Mary N
267 321 16 04	1.00	SFD	D	1.00	1.00	\$0.00	\$0.00	Moselhy Haytham&Brinis Wissem
267 321 16 05	1.00	SFD	D	1.00	1.00	\$0.00	\$0.00	Munoz Jose E Jr&Lindy M
267 321 16 06	1.00	SFD	D	1.00	1.00	\$0.00	\$0.00	Chiong John P
267 321 16 07	1.00	SFD	D	1.00	1.00	\$0.00	\$0.00	Kurtzman Melissa T
267 321 16 08	1.00	SFD	D	1.00	1.00	\$0.00	\$0.00	Tawil Jose J V
267 321 16 09	1.00	SFD	D	1.00	1.00	\$0.00	\$0.00	Tanner Family Trust
267 321 16 10	1.00	SFD	D	1.00	1.00	\$0.00	\$0.00	Kumar Vinu V&Kamalakkannan Sangeetha
267 321 16 11	1.00	SFD	D	1.00	1.00	\$0.00	\$0.00	Eder Clara Trust 07-06-07
267 321 16 12	1.00	SFD	D	1.00	1.00	\$0.00	\$0.00	Hudson David&Jessica
267 330 01 00	1.00	SFD	D	1.00	1.00	\$0.00	\$0.00	King David&Amber
267 330 02 00	1.00	SFD	D	1.00	1.00	\$0.00	\$0.00	Biebel Steven W
267 330 03 00	1.00	SFD	D	1.00	1.00	\$0.00	\$0.00	Hu Qi Dong&Zhou Zhi Hong
267 330 04 00	1.00	SFD	D	1.00	1.00	\$0.00	\$0.00	Nevaras Nicholas&Kristen
267 330 05 00	1.00	SFD	D	1.00	1.00	\$0.00	\$0.00	Attisha Ayad&Melissa
267 330 06 00	1.00	SFD	D	1.00	1.00	\$0.00	\$0.00	Kwon Chang Ki&Shim Sook Kyoung
267 330 07 00	1.00	SFD	D	1.00	1.00	\$0.00	\$0.00	Schofield Bonny C
267 330 08 00	1.00	SFD	D	1.00	1.00	\$0.00	\$0.00	Heine Ryan&Ellis Emily J
267 330 09 00	1.00	SFD	D	1.00	1.00	\$0.00	\$0.00	Chang Michelle E
267 330 10 00	1.00	SFD	D	1.00	1.00	\$0.00	\$0.00	Wong Susanna Ho
267 330 11 00	1.00	SFD	D	1.00	1.00	\$0.00	\$0.00	Farley Family Trust 01-27-14
267 330 12 00	1.00	SFD	D	1.00	1.00	\$0.00	\$0.00	Shin John S&Rayna N
267 330 13 00	1.00	SFD	D	1.00	1.00	\$0.00	\$0.00	Boda Vamsee Krishna Babu&Thummalappalli Padmavathi Devi
267 330 14 00	1.00	SFD	D	1.00	1.00	\$0.00	\$0.00	Popek Ryan T&Krislyn M
267 330 15 00	1.00	SFD	D	1.00	1.00	\$0.00	\$0.00	Campagna Family Trust 08-29-01
267 330 16 00	1.00	SFD	D	1.00	1.00	\$0.00	\$0.00	Perry Wilton A Jr&Georgina
267 330 17 00	1.00	SFD	D	1.00	1.00	\$0.00	\$0.00	Schaeffer Noel E&Denehy Allison D
267 330 18 00	1.00	SFD	D	1.00	1.00	\$0.00	\$0.00	Haughey Family Trust 04-15-14
267 330 19 00	1.00	SFD	D	1.00	1.00	\$0.00	\$0.00	Cunha Oscar&Martinez Jessica
267 330 20 00	1.00	SFD	D	1.00	1.00	\$0.00	\$0.00	Schwartz Jonathan&Cadondon Natalie
267 330 21 00	1.00	SFD	D	1.00	1.00	\$0.00	\$0.00	Driscoll Revocable Decoration Trust 07-28-88
267 330 22 00	1.00	SFD	D	1.00	1.00	\$0.00	\$0.00	Reyes Edgar A&Karen Q
267 330 23 00	1.00	SFD	D	1.00	1.00	\$0.00	\$0.00	Colace Joseph J Iii Family 1998 Trust 04-22-98
267 330 24 00	1.00	SFD	D	1.00	1.00	\$0.00	\$0.00	Burns Mark J
267 330 25 00	1.00	SFD	D	1.00	1.00	\$0.00	\$0.00	Herrera Wilfredo G&Glenda
267 330 26 00	1.00	SFD	D	1.00	1.00	\$0.00	\$0.00	Mitchell Mary J
267 330 27 00	1.00	SFD	D	1.00	1.00	\$0.00	\$0.00	Delmundo Summer
267 330 28 00	1.00	SFD	D	1.00	1.00	\$0.00	\$0.00	Pallela Raja S R&Yenreddy Spurthi
267 330 29 00	1.00	SFD	D	1.00	1.00	\$0.00	\$0.00	Sun Huikai
267 330 30 00	1.00	SFD	D	1.00	1.00	\$0.00	\$0.00	Muga Matthew C&Kimberly E Family Trust 06-02-05
267 330 31 00	1.00	SFD	D	1.00	1.00	\$0.00	\$0.00	Unni Hrishikesh C
267 330 32 00	1.00	SFD	D	1.00	1.00	\$0.00	\$0.00	Fabyan Jay D&Julia E
267 330 33 00	1.00	SFD	D	1.00	1.00	\$0.00	\$0.00	Pham Ngoc T B
267 330 34 00	1.00	SFD	D	1.00	1.00	\$0.00	\$0.00	Cowell Jessica A
267 330 35 00	1.00	SFD	D	1.00	1.00	\$0.00	\$0.00	Timariu Petrea&Luiza
267 330 36 00	1.00	SFD	D	1.00	1.00	\$0.00	\$0.00	Gasser Family Trust 09-01-11
267 330 37 00	1.00	SFD	D	1.00	1.00	\$0.00	\$0.00	Fogel Gregory S&Coel Jeanne A
267 330 38 00	1.00	SFD	D	1.00	1.00	\$0.00	\$0.00	Bromley Jayme L
267 330 39 00	1.00	SFD	D	1.00	1.00	\$0.00	\$0.00	Yung William John Iv&Pamela M

EXHIBIT C - Assessment Roll (Fiscal Year 2017)
Black Mountain Ranch North Maintenance Assessment District

Parcel Number	Acres/ Units ⁽¹⁾	Land Use Code ⁽²⁾	Zone	Land Use Factor ⁽²⁾	Total EBUs	Unit Cost (\$/Ebu)	FY 2017 ⁽³⁾ Assessment	Owner Name
267 330 40 00	1.00	SFD	D	1.00	1.00	\$0.00	\$0.00	Stephan Christina A Revocable Trust 12-15-14
267 330 41 00	1.00	SFD	D	1.00	1.00	\$0.00	\$0.00	Silver Paul&Sylvia Family Trust 02-26-09
267 330 42 00	1.00	SFD	D	1.00	1.00	\$0.00	\$0.00	Ashley Sonia 2012 Trust 09-24-12
267 330 43 00	1.00	SFD	D	1.00	1.00	\$0.00	\$0.00	McLoughlin Trust 09-16-10
267 330 44 00	1.00	SFD	D	1.00	1.00	\$0.00	\$0.00	Doherty Robert F Jr&Melissa L
267 330 45 00	1.00	SFD	D	1.00	1.00	\$0.00	\$0.00	Block Family 2014 Trust 01-09-14
267 330 46 00	1.00	SFD	D	1.00	1.00	\$0.00	\$0.00	Cho Mark K&Kyoungwha
267 330 47 00	1.00	SFD	D	1.00	1.00	\$0.00	\$0.00	Manges Ross G (Dp)
267 330 48 00	1.00	SFD	D	1.00	1.00	\$0.00	\$0.00	Sadhu Hari Krishna&Kodali Mallika
267 330 49 00	1.00	SFD	D	1.00	1.00	\$0.00	\$0.00	Robertson Eric J&Kimberly A
267 330 50 00	1.00	SFD	D	1.00	1.00	\$0.00	\$0.00	Buechler Family Trust 12-16-99
267 330 51 00	1.00	SFD	D	1.00	1.00	\$0.00	\$0.00	Paben Christopher Revocable Trust 06-15-15
267 330 52 00	1.00	SFD	D	1.00	1.00	\$0.00	\$0.00	Salontai Brandon&Rachel
267 330 53 00	1.00	SFD	D	1.00	1.00	\$0.00	\$0.00	Getchell Marcos A&Luciana F
267 330 54 00	1.00	SFD	D	1.00	1.00	\$0.00	\$0.00	Shah&Vora Family Trust 09-17-14
267 330 55 00	1.00	SFD	D	1.00	1.00	\$0.00	\$0.00	Fieldhack Jeffrey&Jennifer
267 330 56 00	1.00	SFD	D	1.00	1.00	\$0.00	\$0.00	Veino Elva L
267 330 57 00	1.00	SFD	D	1.00	1.00	\$0.00	\$0.00	Olson Chad (Dp)
267 330 58 00	1.00	SFD	D	1.00	1.00	\$0.00	\$0.00	Howe Thomas W&Rebecca C
267 330 59 00	1.00	SFD	D	1.00	1.00	\$0.00	\$0.00	Halcomb Family Trust 05-03-91
267 330 60 00	1.00	SFD	D	1.00	1.00	\$0.00	\$0.00	Hanson Ashley J
267 330 61 00	1.00	SFD	D	1.00	1.00	\$0.00	\$0.00	Beck Stephen&Torrey
267 330 62 00	1.00	SFD	D	1.00	1.00	\$0.00	\$0.00	Vieira Eleanor P
267 330 63 00	1.00	SFD	D	1.00	1.00	\$0.00	\$0.00	Loznycky Bill W Jr&Darlene E
267 330 64 00	1.00	SFD	D	1.00	1.00	\$0.00	\$0.00	Khanbolooki Parham
267 330 65 00	1.00	SFD	D	1.00	1.00	\$0.00	\$0.00	Bradley Matthew L&Sara A
267 330 66 00	1.00	SFD	D	1.00	1.00	\$0.00	\$0.00	Schwager Family Trust 03-31-10
267 330 67 00	1.00	SFD	D	1.00	1.00	\$0.00	\$0.00	Becker Mark&Beverly Family Trust 05-18-99
267 330 68 00	1.00	SFD	D	1.00	1.00	\$0.00	\$0.00	Shumate Aaron C&Satsuki K
267 330 69 00	1.00	SFD	D	1.00	1.00	\$0.00	\$0.00	King Raymond C&Hernandez Charlene V
267 330 70 00	0.07	STR	D	0.00	0.00	\$0.00	\$0.00	Delsur Community Assn
267 330 71 00	0.08	STR	D	0.00	0.00	\$0.00	\$0.00	Del Sur Community Assn
267 330 72 00	0.08	STR	D	0.00	0.00	\$0.00	\$0.00	Del Sur Community Assn
267 330 73 00	0.08	STR	D	0.00	0.00	\$0.00	\$0.00	Del Sur Community Assn
267 330 74 00	0.35	STR	D	0.00	0.00	\$0.00	\$0.00	Delsur Community Assn
267 330 75 00	0.22	STR	D	0.00	0.00	\$0.00	\$0.00	Del Sur Community Assn
267 330 76 00	0.33	OSP	D	0.00	0.00	\$0.00	\$0.00	Del Sur Community Assn
267 330 77 00	2.37	OSP	D	0.00	0.00	\$0.00	\$0.00	Del Sur Community Assn
267 330 78 00	0.06	OSP	D	0.00	0.00	\$0.00	\$0.00	Delsur Community Assn
267 330 79 00	0.09	OSP	D	0.00	0.00	\$0.00	\$0.00	Del Sur Community Assn
267 330 80 00	0.20	STR	D	0.00	0.00	\$0.00	\$0.00	Delsur Community Assn
267 340 01 00	1.00	SFD	D	1.00	1.00	\$0.00	\$0.00	Bender Anna M Living Trust 08-05-98
267 340 02 00	1.00	SFD	D	1.00	1.00	\$0.00	\$0.00	Karam John D
267 340 03 00	1.00	SFD	D	1.00	1.00	\$0.00	\$0.00	Saxon Brandon D&Lisa M
267 340 04 00	1.00	SFD	D	1.00	1.00	\$0.00	\$0.00	Tamillo Justin K&Mandy D
267 340 05 00	1.00	SFD	D	1.00	1.00	\$0.00	\$0.00	Kim Kunil&Suhee
267 340 06 00	1.00	SFD	D	1.00	1.00	\$0.00	\$0.00	Butler Nicholas R&Elizabeth A
267 340 07 00	1.00	SFD	D	1.00	1.00	\$0.00	\$0.00	Dasgupta Rajarshi&Banerjee Antara
267 340 08 00	1.00	SFD	D	1.00	1.00	\$0.00	\$0.00	Mahdaviieh Haleh
267 340 09 00	1.00	SFD	D	1.00	1.00	\$0.00	\$0.00	Chen Peter&Shakya Sarita
267 340 10 00	1.00	SFD	D	1.00	1.00	\$0.00	\$0.00	Crutchfield Trust 04-08-14
267 340 11 00	1.00	SFD	D	1.00	1.00	\$0.00	\$0.00	Jones Ryan C&Hande
267 340 12 00	1.00	SFD	D	1.00	1.00	\$0.00	\$0.00	Lawson Diana
267 340 13 00	1.00	SFD	D	1.00	1.00	\$0.00	\$0.00	Gieselman Nathan A&Simone
267 340 14 00	1.00	SFD	D	1.00	1.00	\$0.00	\$0.00	Davidyoung Iii Family Trust
267 340 15 00	1.00	SFD	D	1.00	1.00	\$0.00	\$0.00	Jolly Gautam K&Ahuja Deepiti
267 340 16 00	1.00	SFD	D	1.00	1.00	\$0.00	\$0.00	Felker Damon L&Lauren E
267 340 17 00	1.00	SFD	D	1.00	1.00	\$0.00	\$0.00	Yang Jian
267 340 18 00	1.00	SFD	D	1.00	1.00	\$0.00	\$0.00	Freer Kc&Sydney

EXHIBIT C - Assessment Roll (Fiscal Year 2017)
Black Mountain Ranch North Maintenance Assessment District

Parcel Number	Acres/ Units ⁽¹⁾	Land Use Code ⁽²⁾	Zone	Land Use Factor ⁽²⁾	Total EBUs	Unit Cost (\$/EUBU)	FY 2017 ⁽³⁾ Assessment	Owner Name
267 340 19 00	1.00	SFD	D	1.00	1.00	\$0.00	\$0.00	Holden Jason T&Jeanette W
267 340 20 00	1.00	SFD	D	1.00	1.00	\$0.00	\$0.00	Li Yong&Ge Xinjie
267 340 21 00	1.00	SFD	D	1.00	1.00	\$0.00	\$0.00	Macier Family Trust 11-07-15
267 340 22 00	1.00	SFD	D	1.00	1.00	\$0.00	\$0.00	Tu Thang&Jian Shuzhen
267 340 23 00	1.00	SFD	D	1.00	1.00	\$0.00	\$0.00	Piotrowiak Family Trust 06-05-14
267 340 24 00	1.00	SFD	D	1.00	1.00	\$0.00	\$0.00	Pavis Ian&Lisa M
267 340 25 00	1.00	SFD	D	1.00	1.00	\$0.00	\$0.00	Ryan Trust 05-21-15
267 340 26 00	1.00	SFD	D	1.00	1.00	\$0.00	\$0.00	Land Family Trust 09-11-13
267 340 27 00	1.00	SFD	D	1.00	1.00	\$0.00	\$0.00	Bharadwaj Gowrishankar&Gayatri
267 340 28 00	1.00	SFD	D	1.00	1.00	\$0.00	\$0.00	Hensley Curtis S&Erin R Living Trust 07-22-00
267 340 29 00	1.00	SFD	D	1.00	1.00	\$0.00	\$0.00	Gandara Paul M&Medina Carolyn A
267 340 30 00	1.00	SFD	D	1.00	1.00	\$0.00	\$0.00	Lopez Christopher R&Andrea M
267 340 31 00	1.00	SFD	D	1.00	1.00	\$0.00	\$0.00	Chung Bok-Chul&Yoo Ju
267 340 32 00	1.00	SFD	D	1.00	1.00	\$0.00	\$0.00	Johnson Todd&April
267 340 33 00	1.00	SFD	D	1.00	1.00	\$0.00	\$0.00	Henderson Scott A&Shannon H Family Trust 10-26-11
267 340 34 00	1.00	SFD	D	1.00	1.00	\$0.00	\$0.00	Winters Aaron S&Susan
267 340 35 00	1.00	SFD	D	1.00	1.00	\$0.00	\$0.00	Fullenwider Mervin&Christine
267 340 36 00	1.00	SFD	D	1.00	1.00	\$0.00	\$0.00	Silva Tsneko S
267 340 37 00	1.00	SFD	D	1.00	1.00	\$0.00	\$0.00	Wrotslavsky Philip&Magda M
267 340 38 00	1.00	SFD	D	1.00	1.00	\$0.00	\$0.00	Bennett Maryellen M Family Trust
267 340 39 00	1.00	SFD	D	1.00	1.00	\$0.00	\$0.00	Dragnes Trust 11-09-07
267 340 40 00	1.00	SFD	D	1.00	1.00	\$0.00	\$0.00	Caoile Michael&Jeanne
267 340 41 00	1.00	SFD	D	1.00	1.00	\$0.00	\$0.00	Horn Brad&Stephani
267 340 42 00	1.00	SFD	D	1.00	1.00	\$0.00	\$0.00	Givens Christopher J&Ter-Markarova Lidiya I
267 340 43 00	1.00	SFD	D	1.00	1.00	\$0.00	\$0.00	Sorenson Neil J&Sorensen Karla G
267 340 44 00	1.00	SFD	D	1.00	1.00	\$0.00	\$0.00	Zubrod Family Trust 04-24-12
267 340 45 00	1.00	SFD	D	1.00	1.00	\$0.00	\$0.00	Gilding Jerome A&Trina L
267 340 46 00	1.00	SFD	D	1.00	1.00	\$0.00	\$0.00	Lie Family Trust 03-19-08
267 340 47 00	1.00	SFD	D	1.00	1.00	\$0.00	\$0.00	Reel Family Trust 06-12-12
267 340 48 00	1.00	SFD	D	1.00	1.00	\$0.00	\$0.00	Cheshire Cary&Michelle Family Trust 01-22-10
267 340 49 00	1.00	SFD	D	1.00	1.00	\$0.00	\$0.00	Chan Marcus W&Heidi K
267 340 50 00	1.00	SFD	D	1.00	1.00	\$0.00	\$0.00	Keogh David M&Davis Mindy L
267 340 51 00	1.00	SFD	D	1.00	1.00	\$0.00	\$0.00	Seidenwurm Robert S&Kathryn C
267 340 52 00	1.00	SFD	D	1.00	1.00	\$0.00	\$0.00	Ochsner Todd A&Stephanie
267 340 53 00	1.00	SFD	D	1.00	1.00	\$0.00	\$0.00	Gonzalez Ralph P
267 340 54 00	1.00	SFD	D	1.00	1.00	\$0.00	\$0.00	Johnson Michael E&Shandi O
267 340 55 00	1.00	SFD	D	1.00	1.00	\$0.00	\$0.00	Conrad Skyla Special Needs Trust 03-15-11
267 340 56 00	1.00	SFD	D	1.00	1.00	\$0.00	\$0.00	Tuell Maria
267 340 57 00	1.00	SFD	D	1.00	1.00	\$0.00	\$0.00	Hupp Mary M
267 340 58 00	1.00	SFD	D	1.00	1.00	\$0.00	\$0.00	Vanganuru Kiran K S&Ambati Swathi
267 340 59 00	1.00	SFD	D	1.00	1.00	\$0.00	\$0.00	Furnari Elizabeth&Frank Living Trust 06-21-11
267 340 60 00	1.00	SFD	D	1.00	1.00	\$0.00	\$0.00	Eagan James W Iii&Lisa W
267 340 61 00	1.00	SFD	D	1.00	1.00	\$0.00	\$0.00	Sheedlo Darryl B&Susan L
267 340 62 00	1.00	SFD	D	1.00	1.00	\$0.00	\$0.00	Lane Jeffrey&Kerri
267 340 63 00	1.00	SFD	D	1.00	1.00	\$0.00	\$0.00	Aman Brian T&Maria N
267 340 64 00	1.00	SFD	D	1.00	1.00	\$0.00	\$0.00	Bokelman Kevin&Antonia
267 340 65 00	1.00	SFD	D	1.00	1.00	\$0.00	\$0.00	Sigmon Carter H&Jennifer K
267 340 66 00	1.00	SFD	D	1.00	1.00	\$0.00	\$0.00	Frye James P&Jane G
267 340 67 00	1.00	SFD	D	1.00	1.00	\$0.00	\$0.00	Shanmugaraju Raghuraj&Raj Kavitha
267 340 68 00	1.00	SFD	D	1.00	1.00	\$0.00	\$0.00	Paiva Renato G&Kimberly E
267 340 69 00	1.00	SFD	D	1.00	1.00	\$0.00	\$0.00	16039 Bedford Hill Llc
267 340 70 00	1.00	SFD	D	1.00	1.00	\$0.00	\$0.00	Swanson Thomas J&Laura I
267 340 71 00	0.03	OSP	D	0.00	0.00	\$0.00	\$0.00	Del Sur Community Association
267 340 72 00	0.02	STR	D	0.00	0.00	\$0.00	\$0.00	Del Sur Community Association
267 341 01 00	1.00	SFD	D	1.00	1.00	\$0.00	\$0.00	Takenaga Marc M&Chang Michelle E
267 341 02 00	1.00	SFD	D	1.00	1.00	\$0.00	\$0.00	Kumar Jai G&Sugumar Banmathi K
267 341 03 00	1.00	SFD	D	1.00	1.00	\$0.00	\$0.00	Gray Richard A Iii&Carly D
267 341 04 00	1.00	SFD	D	1.00	1.00	\$0.00	\$0.00	Abed Chung Family Trust 11-15-12
267 341 05 00	1.00	SFD	D	1.00	1.00	\$0.00	\$0.00	Stamoulis Anastasios&Oikonomou Ioanna

EXHIBIT C - Assessment Roll (Fiscal Year 2017)
Black Mountain Ranch North Maintenance Assessment District

Parcel Number	Acres/ Units ⁽¹⁾	Land Use Code ⁽²⁾	Zone	Land Use Factor ⁽²⁾	Total EBUs	Unit Cost (\$/EUBU)	FY 2017 ⁽³⁾ Assessment	Owner Name
267 341 06 00	1.00	SFD	D	1.00	1.00	\$0.00	\$0.00	Lafontaine Bruno&Baker Sherry L
267 341 07 00	1.00	SFD	D	1.00	1.00	\$0.00	\$0.00	Nguyen Khai Hoang
267 341 08 00	1.00	SFD	D	1.00	1.00	\$0.00	\$0.00	Rainier Rajiv&Niru P Family 2014 Trust
267 341 09 00	1.00	SFD	D	1.00	1.00	\$0.00	\$0.00	Brooker Jeffrey A&Engel Katrin
267 341 10 00	1.00	SFD	D	1.00	1.00	\$0.00	\$0.00	Maxwell David W&Charlton Sherri A
267 341 11 00	1.00	SFD	D	1.00	1.00	\$0.00	\$0.00	Zumut Yousef S&Ruba N
267 341 12 00	1.00	SFD	D	1.00	1.00	\$0.00	\$0.00	Armstrong Shayne M&Kelly A
267 341 13 00	1.00	SFD	D	1.00	1.00	\$0.00	\$0.00	Richardson Seth&Wotherspoon Paula
267 341 14 00	1.00	SFD	D	1.00	1.00	\$0.00	\$0.00	Visser Erik
267 341 15 00	1.00	SFD	D	1.00	1.00	\$0.00	\$0.00	Kelts Lucy D Inter Vivos Trust 11-13-108-96
267 341 16 00	1.00	SFD	D	1.00	1.00	\$0.00	\$0.00	Holmes Margaret A
267 341 17 00	1.00	SFD	D	1.00	1.00	\$0.00	\$0.00	Duong Peter D
267 341 18 00	1.00	SFD	D	1.00	1.00	\$0.00	\$0.00	Ciano Ronald A&Kathy A
267 341 19 00	1.00	SFD	D	1.00	1.00	\$0.00	\$0.00	Montana Sean L&Christin M
267 341 20 00	1.00	SFD	D	1.00	1.00	\$0.00	\$0.00	Reule David
267 341 21 00	1.00	SFD	D	1.00	1.00	\$0.00	\$0.00	Katzenmeier Adam
267 341 22 00	1.00	SFD	D	1.00	1.00	\$0.00	\$0.00	Mikoulitch Ivan&Lioudmila
267 341 23 00	0.25	STR	D	0.00	0.00	\$0.00	\$0.00	Del Sur Community Assn
267 341 24 00	1.68	PKU	D	0.50	0.84	\$0.00	\$0.00	Black Mountain Ranch L L C
267 350 01 00	1.00	SFD	E	1.00	1.00	\$0.00	\$0.00	Poirier William A Jr&Ireland Jacqueline C
267 350 02 00	1.00	SFD	E	1.00	1.00	\$0.00	\$0.00	Cohan Family Trust 12-15-15
267 350 03 00	1.00	SFD	E	1.00	1.00	\$0.00	\$0.00	Jenkinson Family Trust 05-06-09
267 350 04 00	1.00	SFD	E	1.00	1.00	\$0.00	\$0.00	Sami Bijan&Adib Mahsa
267 350 05 00	1.00	SFD	E	1.00	1.00	\$0.00	\$0.00	Kurani Nimish&Anupa
267 350 06 00	1.00	SFD	E	1.00	1.00	\$0.00	\$0.00	Chang Sung S&Han Woojeong
267 350 07 00	1.00	SFD	E	1.00	1.00	\$0.00	\$0.00	Park Jae Yong&Lee Ji Young
267 350 08 00	1.00	SFD	E	1.00	1.00	\$0.00	\$0.00	Wolfson Matthew S&Heather G
267 350 09 00	1.00	SFD	E	1.00	1.00	\$0.00	\$0.00	Kenney Brett W&Kristina
267 350 10 00	1.00	SFD	E	1.00	1.00	\$0.00	\$0.00	Neely Mitchell R&Laura T
267 350 11 00	1.00	SFD	E	1.00	1.00	\$0.00	\$0.00	Dharwad Harsh&Singhal Monica
267 350 12 00	1.00	SFD	E	1.00	1.00	\$0.00	\$0.00	Smerican Family Trust 09-21-12
267 350 13 00	1.00	SFD	E	1.00	1.00	\$0.00	\$0.00	Baccanari Patrick A&Melinda M
267 350 14 00	1.00	SFD	E	1.00	1.00	\$0.00	\$0.00	Atella Revocable Family Trust
267 350 15 00	1.00	SFD	E	1.00	1.00	\$0.00	\$0.00	Gao Hongfeng&Kong Lingjun
267 350 16 00	1.00	SFD	E	1.00	1.00	\$0.00	\$0.00	Weiss Joshua
267 350 17 00	1.00	SFD	E	1.00	1.00	\$0.00	\$0.00	Budd Margaret M Living Trust 04-22-92
267 350 18 00	1.00	SFD	E	1.00	1.00	\$0.00	\$0.00	Panda Prasanjit&Sarita
267 350 29 01	1.00	SFD	D	1.00	1.00	\$0.00	\$0.00	Chin Keith
267 350 29 02	1.00	SFD	D	1.00	1.00	\$0.00	\$0.00	Gurumoorthy Krishna K&Ramachandran Srimathi
267 350 30 01	1.00	SFD	D	1.00	1.00	\$0.00	\$0.00	Rosenberg Brian M&Coleman Tara D Revocable Trust 07-14-11
267 350 30 02	1.00	SFD	D	1.00	1.00	\$0.00	\$0.00	Maupin Jason D&Lori D
267 350 31 01	1.00	SFD	D	1.00	1.00	\$0.00	\$0.00	Rubio Jose A&Patricia J
267 350 31 02	1.00	SFD	D	1.00	1.00	\$0.00	\$0.00	Bryan Maureen
267 350 32 01	1.00	SFD	D	1.00	1.00	\$0.00	\$0.00	Smith Michael D&Kari J
267 350 32 02	1.00	SFD	D	1.00	1.00	\$0.00	\$0.00	Ewalt Family Trust 11-18-96
267 350 33 01	1.00	SFD	D	1.00	1.00	\$0.00	\$0.00	Abulafia Lewis H Trust 01-30-14
267 350 33 02	1.00	SFD	D	1.00	1.00	\$0.00	\$0.00	Park Sang-June&Bae Kang Yoon
267 350 34 01	1.00	SFD	D	1.00	1.00	\$0.00	\$0.00	Kowal Gregory M&Shannon L
267 350 34 02	1.00	SFD	D	1.00	1.00	\$0.00	\$0.00	Deng Jian Quan&Li Shu Fen
267 350 35 01	1.00	SFD	D	1.00	1.00	\$0.00	\$0.00	Obodovski Daniel&Rowley Danielle
267 350 35 02	1.00	SFD	D	1.00	1.00	\$0.00	\$0.00	Sonara Nilesh
267 350 36 01	1.00	SFD	D	1.00	1.00	\$0.00	\$0.00	Wang John Y&Alice T
267 350 36 02	1.00	SFD	D	1.00	1.00	\$0.00	\$0.00	Hanley William J Iv&Beatriz A
267 350 37 01	1.00	SFD	D	1.00	1.00	\$0.00	\$0.00	Khatri Himanshu&Seth Parul
267 350 37 02	1.00	SFD	D	1.00	1.00	\$0.00	\$0.00	Liao Kai Hsin&Hsu Wan Chen
267 350 38 01	1.00	SFD	D	1.00	1.00	\$0.00	\$0.00	Nussbaum Joshua
267 350 38 02	1.00	SFD	D	1.00	1.00	\$0.00	\$0.00	Teeter Family Trust 07-27-12
267 350 39 00	1.00	SFD	D	1.00	1.00	\$0.00	\$0.00	Doraisamy Loganathan&Gadde Padmaja
267 350 40 00	1.00	SFD	D	1.00	1.00	\$0.00	\$0.00	Yang Jee Hong&Cho Jihun

EXHIBIT C - Assessment Roll (Fiscal Year 2017)
Black Mountain Ranch North Maintenance Assessment District

Parcel Number	Acres/ Units ⁽¹⁾	Land Use Code ⁽²⁾	Zone	Land Use Factor ⁽²⁾	Total EBUs	Unit Cost (\$/EUBU)	FY 2017 ⁽³⁾ Assessment	Owner Name
267 350 41 00	1.00	SFD	D	1.00	1.00	\$0.00	\$0.00	Kelley Daniel C&Kelly O
267 350 42 00	1.00	SFD	D	1.00	1.00	\$0.00	\$0.00	Ganji Nagamalleswara R&Shashirekha Y
267 350 43 00	1.00	SFD	D	1.00	1.00	\$0.00	\$0.00	Davis Steven J&Oksana B Family Trust 03-20-09
267 350 44 00	1.00	SFD	D	1.00	1.00	\$0.00	\$0.00	Odero Salim&Bullock-Odero Natasha
267 350 45 00	1.00	SFD	D	1.00	1.00	\$0.00	\$0.00	Judelson Inna
267 350 46 00	1.00	SFD	D	1.00	1.00	\$0.00	\$0.00	Dunlap Bruce M&Lazondra W
267 350 47 00	1.00	SFD	D	1.00	1.00	\$0.00	\$0.00	Zunic Valentin&Jasmine
267 350 48 00	1.00	SFD	D	1.00	1.00	\$0.00	\$0.00	Rigg Daynan Separate Property Trust 03-23-12
267 350 49 00	1.00	SFD	D	1.00	1.00	\$0.00	\$0.00	Vulupala Vinod&Chelimita Haritha
267 350 50 00	1.00	SFD	D	1.00	1.00	\$0.00	\$0.00	Thijssen Emanuel P J
267 350 51 01	1.00	SFD	D	1.00	1.00	\$0.00	\$0.00	Smith Thomas Gerard&Loura Diana
267 350 51 02	1.00	SFD	D	1.00	1.00	\$0.00	\$0.00	Askari Kamran
267 350 52 00	1.00	SFD	D	1.00	1.00	\$0.00	\$0.00	Lock David&Theresa Living Trust 01-21-02
267 350 53 00	1.00	SFD	D	1.00	1.00	\$0.00	\$0.00	Bellezzo Joseph M Living Trust 11-01-13
267 350 54 00	1.00	SFD	D	1.00	1.00	\$0.00	\$0.00	Ye Ming&Li Wenlin
267 350 55 00	1.00	SFD	D	1.00	1.00	\$0.00	\$0.00	Lien Vegard&Otoole Rebecca
267 350 56 00	1.00	SFD	D	1.00	1.00	\$0.00	\$0.00	Huang Fusong&Teng Suling
267 350 57 00	1.00	SFD	D	1.00	1.00	\$0.00	\$0.00	Ansari Assad&Kausar Naheed
267 350 58 00	0.21	STR	D	0.00	0.00	\$0.00	\$0.00	Del Sur Community Association
267 350 59 00	0.31	STR	D	0.00	0.00	\$0.00	\$0.00	Del Sur Community Assn
267 350 60 00	0.35	STR	E	0.00	0.00	\$0.00	\$0.00	Del Sur Community Assn
267 350 61 00	0.21	STR	E	0.00	0.00	\$0.00	\$0.00	Delsur Community Assn
267 350 62 00	0.05	STR	D	0.00	0.00	\$0.00	\$0.00	Del Sur Community Assn
267 350 63 00	1.00	SFD	E	1.00	1.00	\$0.00	\$0.00	Trieu Nguyen&Nguyen Xuan
267 350 64 00	1.00	SFD	E	1.00	1.00	\$0.00	\$0.00	Sastrula Venkata R K&Brahmanapally Jyothsna
267 350 65 00	1.00	SFD	E	1.00	1.00	\$0.00	\$0.00	Oltikar Akhil&Bhatia Anisha
267 350 66 00	1.00	SFD	E	1.00	1.00	\$0.00	\$0.00	Kwon Oh Hyung&Shin Hee Sun
267 350 67 00	1.00	SFD	E	1.00	1.00	\$0.00	\$0.00	Crabbe Kevin L&Elke W
267 350 68 00	1.00	SFD	E	1.00	1.00	\$0.00	\$0.00	Bovshow Family Trust 05-03-13
267 350 69 00	1.00	SFD	E	1.00	1.00	\$0.00	\$0.00	Song Danny&Kristine
267 350 70 00	1.00	SFD	E	1.00	1.00	\$0.00	\$0.00	Abboud John S&Kristen L
267 350 71 00	1.00	SFD	E	1.00	1.00	\$0.00	\$0.00	Dominguez Gerardo&Casey Family Trust 02-20-15
267 350 72 00	1.00	SFD	E	1.00	1.00	\$0.00	\$0.00	Brittain Family Trust 07-29-08
267 350 73 00	1.00	SFD	E	1.00	1.00	\$0.00	\$0.00	Motsenbocker Deanne L Trust 06-03-05
267 350 74 00	1.00	SFD	E	1.00	1.00	\$0.00	\$0.00	Rogers Jeffrey&Heather
267 350 75 00	1.00	SFD	E	1.00	1.00	\$0.00	\$0.00	Catubig Rainier C&Amelia S
267 350 76 00	1.00	SFD	E	1.00	1.00	\$0.00	\$0.00	Coffield Karen D
267 350 77 00	1.00	SFD	E	1.00	1.00	\$0.00	\$0.00	Lowdermilk Robert W Jr&Sara M
267 350 78 00	1.00	SFD	E	1.00	1.00	\$0.00	\$0.00	Poojary&Nandalike Family Trust 05-26-13
267 350 79 00	1.00	SFD	E	1.00	1.00	\$0.00	\$0.00	Hameed Hafiz I&Saeed Asma
267 350 80 00	1.00	SFD	E	1.00	1.00	\$0.00	\$0.00	Topolovac Robert F&Eleanor R Trust 02-25-92
267 350 81 00	1.00	SFD	E	1.00	1.00	\$0.00	\$0.00	Tongle Anand&Apoorva
267 350 82 00	1.00	SFD	E	1.00	1.00	\$0.00	\$0.00	Columbia Hotel Inc
267 360 01 00	1.00	SFD	E	1.00	1.00	\$0.00	\$0.00	Lindestaf Trust 05-02-11
267 360 02 00	1.00	SFD	E	1.00	1.00	\$0.00	\$0.00	Sadri Reza
267 360 03 00	1.00	SFD	E	1.00	1.00	\$0.00	\$0.00	Saeman Matthew D&Harrington Rebecca S
267 360 04 00	1.00	SFD	E	1.00	1.00	\$0.00	\$0.00	Gonzales Edmund S&Darcy S
267 360 05 00	1.00	SFD	E	1.00	1.00	\$0.00	\$0.00	Li Fang
267 360 06 00	1.00	SFD	E	1.00	1.00	\$0.00	\$0.00	Yu Sang Cheol&Kang Sung Hee
267 360 07 00	1.00	SFD	E	1.00	1.00	\$0.00	\$0.00	Rangasamy Saravanan M&Rajaram Prathibha M
267 360 08 00	1.00	SFD	E	1.00	1.00	\$0.00	\$0.00	Lewis Family Trust 10-27-98
267 360 09 00	1.00	SFD	E	1.00	1.00	\$0.00	\$0.00	Koenig Steven F&Dana
267 360 10 00	1.00	SFD	E	1.00	1.00	\$0.00	\$0.00	Gonzales Rafael&Christmas V
267 360 11 00	1.00	SFD	E	1.00	1.00	\$0.00	\$0.00	Heaverlo Christopher J&Jennifer A
267 360 12 00	1.00	SFD	E	1.00	1.00	\$0.00	\$0.00	Sun Haitong
267 360 13 00	1.00	SFD	E	1.00	1.00	\$0.00	\$0.00	Ye Tao&Liu Yanzheng
267 360 14 00	1.00	SFD	E	1.00	1.00	\$0.00	\$0.00	Reyes Deo J Jr&Cyndi V
267 360 15 00	1.00	SFD	E	1.00	1.00	\$0.00	\$0.00	Kunnambath Sujeet&Nambiar Sreetha
267 360 16 00	1.00	SFD	E	1.00	1.00	\$0.00	\$0.00	Quijada Luis A&Contreras Maria M

EXHIBIT C - Assessment Roll (Fiscal Year 2017)
Black Mountain Ranch North Maintenance Assessment District

Parcel Number	Acres/ Units ⁽¹⁾	Land Use Code ⁽²⁾	Zone	Land Use Factor ⁽²⁾	Total EBUs	Unit Cost (\$/EUBU)	FY 2017 ⁽³⁾ Assessment	Owner Name
267 360 17 00	1.00	SFD	E	1.00	1.00	\$0.00	\$0.00	Sztanko Eric N&Stacey M
267 360 18 00	1.00	SFD	E	1.00	1.00	\$0.00	\$0.00	Baganz Ryan&Stacey
267 360 19 00	1.00	SFD	E	1.00	1.00	\$0.00	\$0.00	Davenport Stacey Trust 06-28-07
267 360 20 00	1.00	SFD	E	1.00	1.00	\$0.00	\$0.00	Askenazi Eyal
267 360 21 00	1.00	SFD	E	1.00	1.00	\$0.00	\$0.00	Luo Congnan&Li Ni
267 360 22 00	1.00	SFD	E	1.00	1.00	\$0.00	\$0.00	Chin Lane&Van Wendy My Yen
267 360 23 00	1.00	SFD	E	1.00	1.00	\$0.00	\$0.00	Sauer Family Trust
267 360 24 00	1.00	SFD	E	1.00	1.00	\$0.00	\$0.00	Miller Ian J&Martin-Miller Erica G H
267 360 25 00	1.00	SFD	E	1.00	1.00	\$0.00	\$0.00	Arora Amarpal S&Aretz Danielle H
267 360 26 00	1.00	SFD	E	1.00	1.00	\$0.00	\$0.00	Hoong Nien Cong&Szeto Sheirman
267 360 27 00	1.00	SFD	E	1.00	1.00	\$0.00	\$0.00	Badillo Brian&Jocelyn
267 360 28 00	1.00	SFD	E	1.00	1.00	\$0.00	\$0.00	Espino Steve&Sandra L
267 360 29 00	1.00	SFD	E	1.00	1.00	\$0.00	\$0.00	Nicol Maija C
267 360 30 00	1.00	SFD	E	1.00	1.00	\$0.00	\$0.00	Clements Adam&Theresa
267 360 31 00	1.00	SFD	E	1.00	1.00	\$0.00	\$0.00	Gildred Elizabeth A
267 360 32 00	1.00	SFD	E	1.00	1.00	\$0.00	\$0.00	Hayes Ruth F Trust 03-28-96
267 360 33 00	1.00	SFD	E	1.00	1.00	\$0.00	\$0.00	Chin Hsiao-Yi&Lin Annie I Chun
267 360 34 00	1.00	SFD	E	1.00	1.00	\$0.00	\$0.00	Zhai Yufeng&Zhang Hong
267 360 35 00	1.00	SFD	E	1.00	1.00	\$0.00	\$0.00	Azizov Boris&Tamara
267 360 36 00	1.00	SFD	E	1.00	1.00	\$0.00	\$0.00	Norrman Anders J&Marcy E
267 360 37 00	1.00	SFD	E	1.00	1.00	\$0.00	\$0.00	Nasci Alberto&Jennifer L
267 360 38 00	1.00	SFD	E	1.00	1.00	\$0.00	\$0.00	Harms Bradley J&Susan L
267 360 39 00	1.00	SFD	E	1.00	1.00	\$0.00	\$0.00	Danney Brian&Lauren
267 360 40 00	1.00	SFD	E	1.00	1.00	\$0.00	\$0.00	Willis Daniel A&Lynn M
267 360 41 00	1.00	SFD	E	1.00	1.00	\$0.00	\$0.00	Pierson Donald A&Sharp-Pierson Andrea G
267 360 42 00	1.00	SFD	E	1.00	1.00	\$0.00	\$0.00	Halls Tricia G&Mathew D 2011 Revocable Living Trust 01-07-11
267 360 43 00	1.00	SFD	E	1.00	1.00	\$0.00	\$0.00	Theberge Gaston&Barbara A
267 360 44 00	1.00	SFD	E	1.00	1.00	\$0.00	\$0.00	Shrader Adam&Lauren Family Trust 10-16-14
267 360 45 00	1.00	SFD	E	1.00	1.00	\$0.00	\$0.00	Maraju Praveen&Aruri Jayavani
267 360 46 00	1.00	SFD	E	1.00	1.00	\$0.00	\$0.00	Vyas Deepak J&Rinku D
267 360 47 00	1.00	SFD	E	1.00	1.00	\$0.00	\$0.00	George Robert M Jr
267 360 48 00	1.00	SFD	E	1.00	1.00	\$0.00	\$0.00	Reiter Family Trust 04-10-02
267 360 49 00	1.00	SFD	E	1.00	1.00	\$0.00	\$0.00	Huang Diana Di
267 360 50 00	1.00	SFD	E	1.00	1.00	\$0.00	\$0.00	Wallace John R&Michelle L
267 360 51 00	1.00	SFD	E	1.00	1.00	\$0.00	\$0.00	Arora Gautam&Neha
267 360 52 00	1.00	SFD	E	1.00	1.00	\$0.00	\$0.00	Truong Vien
267 360 53 00	1.00	SFD	E	1.00	1.00	\$0.00	\$0.00	Levy Family 2014 Trust 09-23-14
267 360 54 00	1.00	SFD	E	1.00	1.00	\$0.00	\$0.00	Iamele Sommer M&Damon A
267 360 55 00	1.00	SFD	E	1.00	1.00	\$0.00	\$0.00	Wong Liu Family Trust 10-15-14
267 360 56 00	1.00	SFD	E	1.00	1.00	\$0.00	\$0.00	Vo Dang M&Katie L A B Living Trust 03-23-06
267 360 57 00	1.00	SFD	E	1.00	1.00	\$0.00	\$0.00	Dalton William&Kelly Trust 12-19-11
267 360 58 00	1.00	SFD	E	1.00	1.00	\$0.00	\$0.00	Caban Family Trust 11-17-14
267 360 59 00	1.00	SFD	E	1.00	1.00	\$0.00	\$0.00	Casto Hans&Ayumi
267 360 60 00	1.00	SFD	E	1.00	1.00	\$0.00	\$0.00	Hampton Family Trust
267 360 61 00	1.00	SFD	E	1.00	1.00	\$0.00	\$0.00	Ripley Robert Jr&Alison
267 360 62 00	1.00	SFD	E	1.00	1.00	\$0.00	\$0.00	S&S Family Trust 11-11-11
267 360 63 00	1.00	SFD	E	1.00	1.00	\$0.00	\$0.00	Barlow David&Debra
267 360 64 00	1.00	SFD	E	1.00	1.00	\$0.00	\$0.00	Cucinotta Elizabeth
267 360 65 00	1.00	SFD	E	1.00	1.00	\$0.00	\$0.00	Starr Horace J&Nicki J
267 360 66 00	1.00	SFD	E	1.00	1.00	\$0.00	\$0.00	Saad Mark E&Nyree H
267 360 67 00	1.00	SFD	E	1.00	1.00	\$0.00	\$0.00	Ruan Willie&Huang Helen Family Trust 02-11-09
267 360 68 00	1.00	SFD	E	1.00	1.00	\$0.00	\$0.00	Csuja Gilbert M&Monica
267 360 69 00	1.00	SFD	E	1.00	1.00	\$0.00	\$0.00	Bickler Stephen&Clare
267 360 70 00	1.00	SFD	E	1.00	1.00	\$0.00	\$0.00	Matthews Stephen T&Kathryn V Family Revocable Intervivos Tru
267 360 71 00	1.00	SFD	E	1.00	1.00	\$0.00	\$0.00	Hitchcock Family Trust 12-22-09
267 360 72 00	1.00	SFD	E	1.00	1.00	\$0.00	\$0.00	Rinderknecht William J&Stephanie
267 360 73 00	1.00	SFD	E	1.00	1.00	\$0.00	\$0.00	Libby Peter A&Constance D
267 360 74 00	1.72	STR	E	0.00	0.00	\$0.00	\$0.00	Black Mountain Ranch L L C
267 360 75 00	0.32	STR	E	0.00	0.00	\$0.00	\$0.00	Del Sur Community Assn

EXHIBIT C - Assessment Roll (Fiscal Year 2017)
Black Mountain Ranch North Maintenance Assessment District

Parcel Number	Acres/ Units ⁽¹⁾	Land Use Code ⁽²⁾	Zone	Land Use Factor ⁽²⁾	Total EBUs	Unit Cost (\$/EUBU)	FY 2017 ⁽³⁾ Assessment	Owner Name
267 360 76 00	0.32	STR	E	0.00	0.00	\$0.00	\$0.00	Del Sur Community Assn
267 360 77 00	1.48	PKU	E	0.50	0.74	\$0.00	\$0.00	Black Mountain Ranch L L C
267 360 78 00	0.01	OSP	E	0.00	0.00	\$0.00	\$0.00	Del Sur Community Assn
267 360 79 00	0.08	OSP	E	0.00	0.00	\$0.00	\$0.00	Del Sur Community Association
267 360 80 00	0.20	OSP	E	0.00	0.00	\$0.00	\$0.00	Del Sur Community Association
267 360 81 00	0.03	OSP	E	0.00	0.00	\$0.00	\$0.00	Del Sur Community Assn
267 360 82 00	0.03	OSP	E	0.00	0.00	\$0.00	\$0.00	Del Sur Community Assn
267 360 83 00	1.83	OSP	E	0.00	0.00	\$0.00	\$0.00	Del Sur Community Assn
267 360 84 00	1.91	PKU	E	0.50	0.96	\$0.00	\$0.00	Black Mountain Ranch L L C
267 361 01 00	1.00	SFD	E	1.00	1.00	\$0.00	\$0.00	Wilson William R&Michelle Q
267 361 02 00	1.00	SFD	E	1.00	1.00	\$0.00	\$0.00	Peerbolte Gregory J
267 361 03 00	1.00	SFD	E	1.00	1.00	\$0.00	\$0.00	Liu Yi&Li Xuan
267 361 04 00	1.00	SFD	E	1.00	1.00	\$0.00	\$0.00	Chao Edward C&Sarah K
267 361 05 00	1.00	SFD	E	1.00	1.00	\$0.00	\$0.00	Cook Thuy D
267 361 06 00	1.00	SFD	E	1.00	1.00	\$0.00	\$0.00	Bender Family Trust 08-15-03
267 361 07 00	1.00	SFD	E	1.00	1.00	\$0.00	\$0.00	Baini Domingo&Elise
267 361 08 00	1.00	SFD	E	1.00	1.00	\$0.00	\$0.00	Patterson Timothy&Pamela Revocable 2011 Trust
267 361 09 00	1.00	SFD	E	1.00	1.00	\$0.00	\$0.00	Pacheco Yves&Gabriela
267 361 10 00	1.00	SFD	E	1.00	1.00	\$0.00	\$0.00	Butler Traci
267 361 11 00	1.00	SFD	E	1.00	1.00	\$0.00	\$0.00	Guy Kristen L
267 361 12 00	1.00	SFD	E	1.00	1.00	\$0.00	\$0.00	Milazzo Paul A Revocable Trust 11-04-15
267 361 13 00	1.00	SFD	E	1.00	1.00	\$0.00	\$0.00	Mulvihill Debra A Separate Property Trust
267 361 14 00	1.00	SFD	E	1.00	1.00	\$0.00	\$0.00	Vakil Ishfan&Buchh Shimayla
267 361 15 00	1.00	SFD	E	1.00	1.00	\$0.00	\$0.00	Walton Christopher C&Shauna M
267 361 16 00	1.00	SFD	E	1.00	1.00	\$0.00	\$0.00	Hernandez Christopher&Ana
267 361 17 00	1.00	SFD	E	1.00	1.00	\$0.00	\$0.00	Stein Family Trust 06-24-07
267 361 18 00	1.00	SFD	E	1.00	1.00	\$0.00	\$0.00	Chan Harold H&Gaviola-Chan Tina M
267 361 19 00	1.00	SFD	E	1.00	1.00	\$0.00	\$0.00	Kim John C&Maureen
267 361 20 00	1.00	SFD	E	1.00	1.00	\$0.00	\$0.00	Youngflesh Family Trust 02-23-02
267 361 21 00	1.00	SFD	E	1.00	1.00	\$0.00	\$0.00	Zheng Xiping&Chen Xiaoping
267 361 22 00	1.00	SFD	E	1.00	1.00	\$0.00	\$0.00	Mohan Madav S M&Kumar Aparna
267 361 23 00	1.00	SFD	E	1.00	1.00	\$0.00	\$0.00	Gul Bahadir&Meltem S
267 361 24 00	1.00	SFD	E	1.00	1.00	\$0.00	\$0.00	Arp Ramezani Family Trust 04-25-14
267 361 25 00	1.00	SFD	E	1.00	1.00	\$0.00	\$0.00	Campbell Brian E&Kelly
267 361 26 00	1.00	SFD	E	1.00	1.00	\$0.00	\$0.00	Florea Serban&Selaru Paulina
267 361 27 00	1.00	SFD	E	1.00	1.00	\$0.00	\$0.00	Sun Lin
267 361 28 00	1.00	SFD	E	1.00	1.00	\$0.00	\$0.00	Hayes Casey T&Kristi Revocable 2015 Trust 03-06-15
267 361 29 00	1.00	SFD	E	1.00	1.00	\$0.00	\$0.00	Bramble Mark A&Powell Julia A
267 361 30 00	1.00	SFD	E	1.00	1.00	\$0.00	\$0.00	Tullius Lance R&Jennifer R
267 361 31 00	1.00	SFD	E	1.00	1.00	\$0.00	\$0.00	Svetlik Robert S&Larmie M Living 2014 Trust 12-30-14
267 361 32 00	1.00	SFD	E	1.00	1.00	\$0.00	\$0.00	Angelly Kenneth A&Tracy S
267 361 33 00	1.00	SFD	E	1.00	1.00	\$0.00	\$0.00	Nasrallah Fady S&Saliba Rita
267 361 34 00	1.00	SFD	E	1.00	1.00	\$0.00	\$0.00	Mckittrick Todd A&Kimberly L
267 361 35 00	1.00	SFD	E	1.00	1.00	\$0.00	\$0.00	Hua Jun&Li Jun
267 361 36 00	1.00	SFD	E	1.00	1.00	\$0.00	\$0.00	Zhao Catherine Pu
267 361 37 00	1.00	SFD	E	1.00	1.00	\$0.00	\$0.00	Thotakura Sunil K&Baweja Preeti
267 361 38 00	1.00	SFD	E	1.00	1.00	\$0.00	\$0.00	Culmo James M
267 361 39 00	1.00	SFD	E	1.00	1.00	\$0.00	\$0.00	Manor Owen&Julie Famly 2015 Trust
267 361 40 00	1.00	SFD	E	1.00	1.00	\$0.00	\$0.00	Abrams Daniel R&Amy E
267 361 41 00	1.00	SFD	E	1.00	1.00	\$0.00	\$0.00	Vaidyanathan Balaji&Aswath Dipti
267 361 42 00	1.00	SFD	E	1.00	1.00	\$0.00	\$0.00	Tomko Scott&Michelle
267 361 43 00	1.00	SFD	E	1.00	1.00	\$0.00	\$0.00	Tseng Yi-Hung&Chou Jaime
267 361 44 00	1.00	SFD	E	1.00	1.00	\$0.00	\$0.00	Sage Christopher M&Catherine C
267 361 45 00	1.00	SFD	E	1.00	1.00	\$0.00	\$0.00	Carlberg Jeffrey M&Michelle M
267 361 46 00	1.00	SFD	E	1.00	1.00	\$0.00	\$0.00	Jaiswal Rakesh K&Shikha
267 361 47 00	1.00	SFD	E	1.00	1.00	\$0.00	\$0.00	Le Richard
267 361 48 00	1.00	SFD	E	1.00	1.00	\$0.00	\$0.00	Ahuja Sandeep&Sonia
267 361 49 00	1.00	SFD	E	1.00	1.00	\$0.00	\$0.00	Loganathan Harinathan&Kannan Swapna
267 361 50 00	1.00	SFD	E	1.00	1.00	\$0.00	\$0.00	Schraven Family Trust 01-10-13

EXHIBIT C - Assessment Roll (Fiscal Year 2017)
Black Mountain Ranch North Maintenance Assessment District

Parcel Number	Acres/ Units ⁽¹⁾	Land Use Code ⁽²⁾	Zone	Land Use Factor ⁽²⁾	Total EBUs	Unit Cost (\$/Ebu)	FY 2017 ⁽³⁾ Assessment	Owner Name
267 361 51 00	1.00	SFD	E	1.00	1.00	\$0.00	\$0.00	Carneal David
267 361 52 00	1.00	SFD	E	1.00	1.00	\$0.00	\$0.00	Braness Revocable Trust 09-09-13
267 361 53 00	1.00	SFD	E	1.00	1.00	\$0.00	\$0.00	Waldrop Family Trust
267 361 54 00	1.00	SFD	E	1.00	1.00	\$0.00	\$0.00	Chen Ming Chun&Ren Zhi
267 361 55 00	1.00	SFD	E	1.00	1.00	\$0.00	\$0.00	Asgari Mohammad A&Fereshteh
267 361 56 00	1.00	SFD	E	1.00	1.00	\$0.00	\$0.00	Lau Kelvin Hok&King Ya-Ling
267 361 57 00	1.00	SFD	E	1.00	1.00	\$0.00	\$0.00	Estrada Lindsay R&Justina M
267 361 58 00	1.00	SFD	E	1.00	1.00	\$0.00	\$0.00	Trivedi Riddhish&Tejus Living Trust 01-05-16
267 361 59 00	1.00	SFD	E	1.00	1.00	\$0.00	\$0.00	Davuluri Gandhi&Chitturi Swathi
267 361 60 00	0.15	STR	E	0.00	0.00	\$0.00	\$0.00	Del Sur Community Assn
267 361 61 00	0.71	PKU	E	0.50	0.36	\$0.00	\$0.00	Black Mountain Ranch L L C
267 361 62 00	0.36	OSP	E	0.00	0.00	\$0.00	\$0.00	Del Sur Community Assn
267 361 63 00	0.05	OSP	E	0.00	0.00	\$0.00	\$0.00	Del Sur Community Assn
267 361 64 00	0.15	OSP	E	0.00	0.00	\$0.00	\$0.00	Del Sur Community Assn
267 361 65 00	0.03	OSP	E	0.00	0.00	\$0.00	\$0.00	Del Sur Community Assn
267 361 66 00	0.20	OSP	E	0.00	0.00	\$0.00	\$0.00	Black Mountain Ranch L L C
267 362 01 00	1.00	SFD	E	1.00	1.00	\$0.00	\$0.00	Kaechele Joshua J&Kelly H
267 362 02 00	1.00	SFD	E	1.00	1.00	\$0.00	\$0.00	Bui Steve T&Miller Kimberly J
267 362 03 00	1.00	SFD	E	1.00	1.00	\$0.00	\$0.00	Mccluer Family Living Trust 07-09-12
267 362 04 00	1.00	SFD	E	1.00	1.00	\$0.00	\$0.00	Millett Nicole K Separate Property Trust 10-17-12
267 362 05 00	1.00	SFD	E	1.00	1.00	\$0.00	\$0.00	Vo Khanh
267 362 06 00	1.00	SFD	E	1.00	1.00	\$0.00	\$0.00	Im Jim&Ellen
267 362 07 00	1.00	SFD	E	1.00	1.00	\$0.00	\$0.00	Haripotepornkul Cy&Nora H
267 362 08 00	1.00	SFD	E	1.00	1.00	\$0.00	\$0.00	Zhu Zhengbo
267 362 09 00	1.00	SFD	E	1.00	1.00	\$0.00	\$0.00	Oteri Oghenekome&Awoniye-Oteri Olufunmilola
267 362 10 00	1.00	SFD	E	1.00	1.00	\$0.00	\$0.00	Pei James&Ma Li-Chen
267 362 11 00	1.00	SFD	E	1.00	1.00	\$0.00	\$0.00	Miller Family 2015 Trust 02-04-15
267 362 12 00	1.00	SFD	E	1.00	1.00	\$0.00	\$0.00	Xing Honglao&Fu Peilin
267 362 13 00	1.00	SFD	E	1.00	1.00	\$0.00	\$0.00	Humeau Laurent&Ni Yajin
267 362 14 00	1.00	SFD	E	1.00	1.00	\$0.00	\$0.00	Vo Dang Minh&Katie Lee A B Living Trust
267 362 15 00	1.00	SFD	E	1.00	1.00	\$0.00	\$0.00	Mackinlay Family Trust 06-10-10
267 362 16 00	1.00	SFD	E	1.00	1.00	\$0.00	\$0.00	Lam Vincent S&Candace T
267 362 17 00	1.00	SFD	E	1.00	1.00	\$0.00	\$0.00	Wang Wendy Revocable Trust 05-12-09
267 362 18 00	1.00	SFD	E	1.00	1.00	\$0.00	\$0.00	Jundt Family Trust 07-21-15
267 362 19 00	1.00	SFD	E	1.00	1.00	\$0.00	\$0.00	Jarvis Scott&Bertha
267 362 20 00	1.00	SFD	E	1.00	1.00	\$0.00	\$0.00	Ridge Trust 08-28-13
267 362 21 00	1.00	SFD	E	1.00	1.00	\$0.00	\$0.00	Shalon Kevin&Samantha
267 362 22 00	1.00	SFD	E	1.00	1.00	\$0.00	\$0.00	Cho Jackie M
267 362 23 00	1.00	SFD	E	1.00	1.00	\$0.00	\$0.00	Lamont Lawrence W Jr&Erika L
267 362 24 00	1.00	SFD	E	1.00	1.00	\$0.00	\$0.00	Ratray Jason&Kristina M
267 362 25 00	1.00	SFD	E	1.00	1.00	\$0.00	\$0.00	Currier Family Trust 05-05-11
267 362 26 00	1.00	SFD	E	1.00	1.00	\$0.00	\$0.00	Khandelwal Girish&Pharkya Priti
267 362 27 00	1.00	SFD	E	1.00	1.00	\$0.00	\$0.00	Huott Patrick A&Karen L
267 362 28 00	1.00	SFD	E	1.00	1.00	\$0.00	\$0.00	Dang Hai&Nguyen Thao
267 362 29 00	1.00	SFD	E	1.00	1.00	\$0.00	\$0.00	Zhou Minhua&Yu Yanqing
267 362 30 00	1.00	SFD	E	1.00	1.00	\$0.00	\$0.00	Sundar Shyam&Gandhimathi
267 362 31 00	1.00	SFD	E	1.00	1.00	\$0.00	\$0.00	Gannon Joseph P&Morgan-Gannon Sally J
267 362 32 00	1.00	SFD	E	1.00	1.00	\$0.00	\$0.00	Pohle Jr Family Trust 11-18-04
267 362 33 00	1.00	SFD	E	1.00	1.00	\$0.00	\$0.00	Milne Amy L Family Trust 03-06-15
267 362 34 00	1.00	SFD	E	1.00	1.00	\$0.00	\$0.00	Williams Family Trust 05-02-13
267 362 35 00	1.00	SFD	E	1.00	1.00	\$0.00	\$0.00	S&A San Diego L L C
267 362 36 00	1.00	SFD	E	1.00	1.00	\$0.00	\$0.00	Warner Ingemar S&Julie P Trs
267 362 37 00	1.00	SFD	E	1.00	1.00	\$0.00	\$0.00	Welch Gary K&Rebecca D
267 362 38 00	1.00	SFD	E	1.00	1.00	\$0.00	\$0.00	Stevens Lori A
267 362 39 00	1.00	SFD	E	1.00	1.00	\$0.00	\$0.00	Cowan Robert&Jenny
267 362 40 00	1.00	SFD	E	1.00	1.00	\$0.00	\$0.00	Swartzentruber Jon L&Trent Jane M
267 362 41 00	1.00	SFD	E	1.00	1.00	\$0.00	\$0.00	Broquard Dean J Revocable Trust 07-23-03
267 362 42 00	1.00	SFD	E	1.00	1.00	\$0.00	\$0.00	Deschamps Family Trust 01-09-12
267 362 43 00	1.00	SFD	E	1.00	1.00	\$0.00	\$0.00	Mojaver Family Trust 09-26-00

EXHIBIT C - Assessment Roll (Fiscal Year 2017)
Black Mountain Ranch North Maintenance Assessment District

Parcel Number	Acres/ Units ⁽¹⁾	Land Use Code ⁽²⁾	Zone	Land Use Factor ⁽²⁾	Total EBUs	Unit Cost (\$/EBU)	FY 2017 ⁽³⁾ Assessment	Owner Name
267 362 44 00	1.00	SFD	E	1.00	1.00	\$0.00	\$0.00	Eichhoff-Bergmann Trust 04-04-11
267 362 45 00	1.00	SFD	E	1.00	1.00	\$0.00	\$0.00	Scott Clifton E&Melissa L
267 362 46 00	1.00	SFD	E	1.00	1.00	\$0.00	\$0.00	Murphy Family Trust 10-21-00
267 362 47 00	1.00	SFD	E	1.00	1.00	\$0.00	\$0.00	Ferraro John&Catherine A
267 362 48 00	1.00	SFD	E	1.00	1.00	\$0.00	\$0.00	Wilson Brian M&Sarah J
267 362 49 00	1.00	SFD	E	1.00	1.00	\$0.00	\$0.00	Mann James I&Rochelle C
267 362 50 00	1.00	SFD	E	1.00	1.00	\$0.00	\$0.00	Zhou Zhengyu&Zhu Min
267 362 51 00	1.00	SFD	E	1.00	1.00	\$0.00	\$0.00	Bonamour Gregory&Samantha
267 362 52 00	1.00	SFD	E	1.00	1.00	\$0.00	\$0.00	Swanson Timothy J&Sara J
267 362 53 00	1.00	SFD	E	1.00	1.00	\$0.00	\$0.00	Cerasuolo Anthony&Jacquelyn Trust 02-03-11
267 362 54 00	1.00	SFD	E	1.00	1.00	\$0.00	\$0.00	Westphal-Siblesz Family Trust 03-29-99
267 362 55 00	1.00	SFD	E	1.00	1.00	\$0.00	\$0.00	Hossain Asif&Hussain Naila
267 362 56 00	1.00	SFD	E	1.00	1.00	\$0.00	\$0.00	Assi Hani A&Tina R
267 362 57 00	0.08	STR	E	0.00	0.00	\$0.00	\$0.00	Del Sur Community Assn
267 362 58 00	1.52	STR	E	0.00	0.00	\$0.00	\$0.00	Black Mountain Ranch L L C
267 362 59 00	0.10	STR	E	0.00	0.00	\$0.00	\$0.00	Del Sur Community Assn
267 362 60 00	0.16	STR	E	0.00	0.00	\$0.00	\$0.00	Del Sur Community Assn
267 362 61 00	0.35	OSP	E	0.00	0.00	\$0.00	\$0.00	Black Mountain Ranch L L C
267 362 62 00	1.14	OSP	E	0.00	0.00	\$0.00	\$0.00	Del Sur Community Assn
267 362 63 00	0.05	OSP	E	0.00	0.00	\$0.00	\$0.00	Del Sur Community Assn
267 362 64 00	0.10	OSP	E	0.00	0.00	\$0.00	\$0.00	Del Sur Community Assn
267 362 65 00	0.35	STR	E	0.00	0.00	\$0.00	\$0.00	Del Sur Community Assn
267 363 01 00	1.00	SFD	E	1.00	1.00	\$0.00	\$0.00	Sidhwa Farhad&Ferahiz
267 363 02 00	1.00	SFD	E	1.00	1.00	\$0.00	\$0.00	Hsu Paul R&Melissa E
267 363 03 00	1.00	SFD	E	1.00	1.00	\$0.00	\$0.00	Lai Mitchell&Michelle
267 363 04 00	1.00	SFD	E	1.00	1.00	\$0.00	\$0.00	Tellers Clayton&Jennifer
267 363 05 00	1.00	SFD	E	1.00	1.00	\$0.00	\$0.00	Quintlan Thomas&Tyler
267 363 06 00	1.00	SFD	E	1.00	1.00	\$0.00	\$0.00	Parikh Parag&Melissa
267 363 07 00	1.00	SFD	E	1.00	1.00	\$0.00	\$0.00	Albert Francis&Amanda
267 363 08 00	1.00	SFD	E	1.00	1.00	\$0.00	\$0.00	Huntsman Family Trust 08-07-15
267 363 21 00	1.10	OSP	E	0.00	0.00	\$0.00	\$0.00	Black Mountain Ranch L L C
267 363 23 00	1.00	SFD	E	1.00	1.00	\$0.00	\$0.00	Ramjit Martin&Sirpa
267 363 24 00	1.00	SFD	E	1.00	1.00	\$0.00	\$0.00	Gounder Sivaraman K
267 363 25 00	1.00	SFD	E	1.00	1.00	\$0.00	\$0.00	Riegle Donald W&Hansen-Riegle Lori
267 363 26 00	1.00	SFD	E	1.00	1.00	\$0.00	\$0.00	Singh Dhananjai
267 363 27 00	1.00	SFD	E	1.00	1.00	\$0.00	\$0.00	Meijers Family Trust 06-05-14
267 363 28 00	1.00	SFD	E	1.00	1.00	\$0.00	\$0.00	Johns Glenn C&Sarah E
267 363 29 00	1.00	SFD	E	1.00	1.00	\$0.00	\$0.00	Dubov-Zamansky Trust 05-29-14
267 363 30 00	1.00	SFD	E	1.00	1.00	\$0.00	\$0.00	Godoski Jan L Jr&Chan Wai-Yin
267 363 31 00	1.00	SFD	E	1.00	1.00	\$0.00	\$0.00	Harper Dan O&Kozlowski Cheryl A
267 363 32 00	1.00	SFD	E	1.00	1.00	\$0.00	\$0.00	Milliron John R&Christine N
267 363 33 00	0.23	OSP	E	0.00	0.00	\$0.00	\$0.00	Del Sur Community Association
267 363 34 00	2.54	OSP	E	0.00	0.00	\$0.00	\$0.00	Del Sur Community Association
267 363 35 00	0.15	STR	E	0.00	0.00	\$0.00	\$0.00	Del Sur Community Association
267 364 01 00	1.00	SFD	E	1.00	1.00	\$0.00	\$0.00	Pahler Ryan M&Kathy
267 364 08 00	1.00	SFD	E	1.00	1.00	\$0.00	\$0.00	Saks Neil&Susan J
267 364 09 00	1.00	SFD	E	1.00	1.00	\$0.00	\$0.00	Jacobi Gregory&Elizabeth
267 364 16 00	1.00	SFD	E	1.00	1.00	\$0.00	\$0.00	Schramm Kevin&Stacey L Living Trust 04-18-12
267 364 17 00	1.00	SFD	E	1.00	1.00	\$0.00	\$0.00	Sanguinetti Carlos F&Shana D
267 364 18 00	1.00	SFD	E	1.00	1.00	\$0.00	\$0.00	Hayden Jeremiah C Living Trust 04-24-11
267 364 19 00	1.00	SFD	E	1.00	1.00	\$0.00	\$0.00	Crain Allison
267 364 20 00	1.00	SFD	E	1.00	1.00	\$0.00	\$0.00	Eberhardt Karl B&Julie W
267 364 21 00	0.12	STR	E	0.00	0.00	\$0.00	\$0.00	Brookfield D S 51 L L C
267 364 22 00	0.25	OSP	E	0.00	0.00	\$0.00	\$0.00	Black Mountain Ranch L L C
267 364 23 00	0.08	OSP	E	0.00	0.00	\$0.00	\$0.00	Del Sur Community Assn
267 364 24 00	0.12	OSP	E	0.00	0.00	\$0.00	\$0.00	Black Mountain Ranch L L C
267 364 26 00	0.14	STR	E	0.00	0.00	\$0.00	\$0.00	Brookfield D S 51 L L C
267 364 27 00	1.00	SFD	E	1.00	1.00	\$0.00	\$0.00	Otto Daniel&Deborah Revocable Trust
267 364 28 00	1.00	SFD	E	1.00	1.00	\$0.00	\$0.00	Shah Dhawal&Shrishrimal Sumi

EXHIBIT C - Assessment Roll (Fiscal Year 2017)
Black Mountain Ranch North Maintenance Assessment District

Parcel Number	Acres/ Units ⁽¹⁾	Land Use Code ⁽²⁾	Zone	Land Use Factor ⁽²⁾	Total EBUs	Unit Cost (\$/EUBU)	FY 2017 ⁽³⁾ Assessment	Owner Name
267 364 29 00	1.00	SFD	E	1.00	1.00	\$0.00	\$0.00	Berenter Monica
267 364 30 00	1.00	SFD	E	1.00	1.00	\$0.00	\$0.00	Hugli Kevin T&Kelly
267 364 31 00	1.00	SFD	E	1.00	1.00	\$0.00	\$0.00	Taleppady Anil&Vidya
267 364 32 00	1.00	SFD	E	1.00	1.00	\$0.00	\$0.00	Smirnova Anzhelika
267 364 33 00	1.00	SFD	E	1.00	1.00	\$0.00	\$0.00	Ekambaram Shankar&Soundarraju Sridevi
267 364 34 00	1.00	SFD	E	1.00	1.00	\$0.00	\$0.00	Yang Chao-Shun&Du Tingting
267 364 35 00	1.00	SFD	E	1.00	1.00	\$0.00	\$0.00	Jaffke John P&Darlene M
267 364 36 00	1.00	SFD	E	1.00	1.00	\$0.00	\$0.00	Dhanasekaran Vijayakumar&Anbarasan Amrita P
267 364 37 00	1.00	SFD	E	1.00	1.00	\$0.00	\$0.00	Cubas Ivan&Castaneda Janeth
267 364 38 00	1.00	SFD	E	1.00	1.00	\$0.00	\$0.00	Meeks Brandon&Jennifer
267 364 39 00	4.29	OSP	E	0.00	0.00	\$0.00	\$0.00	Black Mountain Ranch L L C
267 365 01 00	2.24	OSP	E	0.00	0.00	\$0.00	\$0.00	Del Sur Community Assn
267 365 02 00	15.35	OSP	E	0.00	0.00	\$0.00	\$0.00	Black Mountain Ranch L L C
267 370 01 01	1.00	CND	E	0.70	0.70	\$0.00	\$0.00	Ecleonel Agosto&Rosalina
267 370 01 02	1.00	CND	E	0.70	0.70	\$0.00	\$0.00	Ng Andrew X
267 370 01 03	1.00	CND	E	0.70	0.70	\$0.00	\$0.00	Eisenmeyer Florence Revocable Trust 12-30-03
267 370 01 04	1.00	CND	E	0.70	0.70	\$0.00	\$0.00	Wong Genaro
267 370 01 05	1.00	CND	E	0.70	0.70	\$0.00	\$0.00	Fatlund Dan E Revocable 2008 Trust 08-26-08
267 370 01 06	1.00	CND	E	0.70	0.70	\$0.00	\$0.00	Zabonik Mark A&Kelli A
267 370 01 07	1.00	CND	E	0.70	0.70	\$0.00	\$0.00	Jackson Daryl J&Breanna
267 370 01 08	1.00	CND	E	0.70	0.70	\$0.00	\$0.00	Marshall Shawn&Elizabeth
267 370 01 09	1.00	CND	E	0.70	0.70	\$0.00	\$0.00	Yin Mingming&Li Xuan
267 370 01 10	1.00	CND	E	0.70	0.70	\$0.00	\$0.00	Perez Rafael
267 370 01 11	1.00	CND	E	0.70	0.70	\$0.00	\$0.00	Jafarzade Farhad&Godarzi Goli
267 370 01 12	1.00	CND	E	0.70	0.70	\$0.00	\$0.00	Lanier Susan J
267 370 01 13	1.00	CND	E	0.70	0.70	\$0.00	\$0.00	Dahiya Pavel
267 370 01 14	1.00	CND	E	0.70	0.70	\$0.00	\$0.00	Yung Yun C&Tith Tevy
267 370 01 15	1.00	CND	E	0.70	0.70	\$0.00	\$0.00	Rochelle Brian&Michele
267 370 01 16	1.00	CND	E	0.70	0.70	\$0.00	\$0.00	Gabel Michael
267 370 01 17	1.00	CND	E	0.70	0.70	\$0.00	\$0.00	Skeen Amanda
267 370 01 18	1.00	CND	E	0.70	0.70	\$0.00	\$0.00	Giri Rajasekhar S&Chandu Madhuri
267 370 01 19	1.00	CND	E	0.70	0.70	\$0.00	\$0.00	Vemulapalli Fanil&Sunkara Sowjanya
267 370 01 20	1.00	CND	E	0.70	0.70	\$0.00	\$0.00	Vanvaley Michael S&Patricia R
267 370 01 21	1.00	CND	E	0.70	0.70	\$0.00	\$0.00	Nguyen Natalie T
267 370 01 22	1.00	CND	E	0.70	0.70	\$0.00	\$0.00	Choi Wooram
267 370 01 23	1.00	CND	E	0.70	0.70	\$0.00	\$0.00	Xu Larry&Park Yoon Kyung
267 370 01 24	1.00	CND	E	0.70	0.70	\$0.00	\$0.00	Cerasoli Kristi A
267 370 01 25	1.00	CND	E	0.70	0.70	\$0.00	\$0.00	Slosser Michael Trust 01-23-12
267 370 01 26	1.00	CND	E	0.70	0.70	\$0.00	\$0.00	Venkitasamy Jeganathan&Chakraborty Debjani
267 370 01 27	1.00	CND	E	0.70	0.70	\$0.00	\$0.00	Ghadiri Fatemeh
267 370 01 28	1.00	CND	E	0.70	0.70	\$0.00	\$0.00	Park Brandyce S Trust 09-21-09
267 370 01 29	1.00	CND	E	0.70	0.70	\$0.00	\$0.00	Kreiss James D&Dubansky Julie A
267 370 01 30	1.00	CND	E	0.70	0.70	\$0.00	\$0.00	Frey Tracy N
267 370 01 31	1.00	CND	E	0.70	0.70	\$0.00	\$0.00	Powell Seiho N&Powell-Tran Loan Thi
267 370 01 32	1.00	CND	E	0.70	0.70	\$0.00	\$0.00	Tse Alexander B
267 370 01 33	1.00	CND	E	0.70	0.70	\$0.00	\$0.00	Leng Bing&Zhao Allison
267 370 01 34	1.00	CND	E	0.70	0.70	\$0.00	\$0.00	Clark William J&Robert M
267 370 01 35	1.00	CND	E	0.70	0.70	\$0.00	\$0.00	Song Frank Yanling&Ying
267 370 01 36	1.00	CND	E	0.70	0.70	\$0.00	\$0.00	Castillo David M&Alexandra M
267 370 01 37	1.00	CND	E	0.70	0.70	\$0.00	\$0.00	Stample John T&Jessica M
267 370 01 38	1.00	CND	E	0.70	0.70	\$0.00	\$0.00	Desai Hitesh J&Niral H
267 370 01 39	1.00	CND	E	0.70	0.70	\$0.00	\$0.00	Asbury Beau D&Marion J
267 370 01 40	1.00	CND	E	0.70	0.70	\$0.00	\$0.00	Gordon Julie R
267 370 01 41	1.00	CND	E	0.70	0.70	\$0.00	\$0.00	Huneke James&Diane Trust 07-30-01
267 370 01 42	1.00	CND	E	0.70	0.70	\$0.00	\$0.00	Eckel Debra S Separate Property Trust 03-30-15
267 370 01 43	1.00	CND	E	0.70	0.70	\$0.00	\$0.00	Arnold Michael J&Karen A
267 370 01 44	1.00	CND	E	0.70	0.70	\$0.00	\$0.00	Covington Gregory E Jr
267 370 01 45	1.00	CND	E	0.70	0.70	\$0.00	\$0.00	Bhatia Supreet&Manmeet
267 370 01 46	1.00	CND	E	0.70	0.70	\$0.00	\$0.00	Ni Jun&Chen Ying

EXHIBIT C - Assessment Roll (Fiscal Year 2017)
Black Mountain Ranch North Maintenance Assessment District

Parcel Number	Acres/ Units ⁽¹⁾	Land Use Code ⁽²⁾	Zone	Land Use Factor ⁽²⁾	Total EBUs	Unit Cost (\$/EUBU)	FY 2017 ⁽³⁾ Assessment	Owner Name
267 370 01 47	1.00	CND	E	0.70	0.70	\$0.00	\$0.00	Oteri Oghenekome F&Awoniyi Olufunmilola O
267 370 01 48	1.00	CND	E	0.70	0.70	\$0.00	\$0.00	Chernow Duane&Casteel Lisa
267 370 01 49	1.00	CND	E	0.70	0.70	\$0.00	\$0.00	Pirolli Thomas J Jr&Lisa D
267 370 01 50	1.00	CND	E	0.70	0.70	\$0.00	\$0.00	Scharf Eric&Sherri
267 370 01 51	1.00	CND	E	0.70	0.70	\$0.00	\$0.00	Tom Wynniss
267 370 01 52	1.00	CND	E	0.70	0.70	\$0.00	\$0.00	Lobanov Igor&Yuliya
267 370 01 53	1.00	CND	E	0.70	0.70	\$0.00	\$0.00	Minachi Safa
267 370 01 54	1.00	CND	E	0.70	0.70	\$0.00	\$0.00	Hunsaker Robert M
267 370 01 55	1.00	CND	E	0.70	0.70	\$0.00	\$0.00	Arandjelovic Michelle
267 370 02 00	5.08	PKD	E	5.00	25.40	\$0.00	\$0.00	Black Mountain Ranch L L C
267 370 03 00	2.47	PKU	E	0.50	1.24	\$0.00	\$0.00	Black Mountain Ranch L L C
267 370 04 00	10.31	EPS	E	5.00	51.55	\$0.00	\$0.00	Poway Unified School District
267 370 05 00	11.15	OSP	E	0.00	0.00	\$0.00	\$0.00	Black Mountain Ranch L L C
267 370 06 00	0.20	OSP	E	0.00	0.00	\$0.00	\$0.00	Black Mountain Ranch L L C
267 380 01 00	1.00	SFD	C	1.00	1.00	\$0.00	\$0.00	Bunn Family Trust 11-08-00
267 380 02 00	1.00	SFD	C	1.00	1.00	\$0.00	\$0.00	Makkar Narinder S&Raminder K
267 380 03 00	1.00	SFD	C	1.00	1.00	\$0.00	\$0.00	King Wende&James King Family Trust
267 380 04 00	1.00	SFD	C	1.00	1.00	\$0.00	\$0.00	Sherwood Robert W&Farella-Sherwood Pamela Trust 10-02-99
267 380 05 00	1.00	SFD	C	1.00	1.00	\$0.00	\$0.00	Rebel Family Trust 08-26-05
267 380 06 00	1.00	SFD	C	1.00	1.00	\$0.00	\$0.00	Black Mountain Ranch L L C
267 380 07 00	1.00	SFD	C	1.00	1.00	\$0.00	\$0.00	Black Mountain Ranch L L C
267 380 08 00	1.00	SFD	C	1.00	1.00	\$0.00	\$0.00	Black Mountain Ranch L L C
267 380 09 00	1.00	SFD	C	1.00	1.00	\$0.00	\$0.00	Black Mountain Ranch L L C
267 380 10 00	1.00	SFD	C	1.00	1.00	\$0.00	\$0.00	Black Mountain Ranch L L C
267 380 11 00	1.00	SFD	C	1.00	1.00	\$0.00	\$0.00	Black Mountain Ranch L L C
267 380 12 00	1.00	SFD	C	1.00	1.00	\$0.00	\$0.00	Black Mountain Ranch L L C
267 380 13 00	1.00	SFD	C	1.00	1.00	\$0.00	\$0.00	Black Mountain Ranch L L C
267 380 14 00	1.00	SFD	C	1.00	1.00	\$0.00	\$0.00	Black Mountain Ranch L L C
267 380 15 00	1.00	SFD	C	1.00	1.00	\$0.00	\$0.00	Black Mountain Ranch L L C
267 380 16 00	1.00	SFD	C	1.00	1.00	\$0.00	\$0.00	Black Mountain Ranch L L C
267 380 17 00	1.00	SFD	C	1.00	1.00	\$0.00	\$0.00	Black Mountain Ranch L L C
267 380 18 00	1.00	SFD	C	1.00	1.00	\$0.00	\$0.00	Black Mountain Ranch L L C
267 380 19 00	1.00	SFD	C	1.00	1.00	\$0.00	\$0.00	Black Mountain Ranch L L C
267 380 20 00	1.00	SFD	C	1.00	1.00	\$0.00	\$0.00	Mandell Andrew&Adele
267 380 21 00	1.00	SFD	C	1.00	1.00	\$0.00	\$0.00	Baek Paul N&Abler Sandra L
267 380 22 00	1.00	SFD	C	1.00	1.00	\$0.00	\$0.00	Nahm James Trust 06-07-00
267 380 23 00	1.76	OSP	C	0.00	0.00	\$0.00	\$0.00	Black Mountain Ranch L L C
267 380 24 00	0.78	STR	C	0.00	0.00	\$0.00	\$0.00	Black Mountain Ranch L L C
267 380 25 00	0.02	OSP	C	0.00	0.00	\$0.00	\$0.00	Black Mountain Ranch L L C
267 380 26 00	0.03	OSP	C	0.00	0.00	\$0.00	\$0.00	Black Mountain Ranch L L C
267 380 27 00	0.03	OSP	C	0.00	0.00	\$0.00	\$0.00	Black Mountain Ranch L L C
267 380 28 00	0.03	OSP	C	0.00	0.00	\$0.00	\$0.00	Black Mountain Ranch L L C
267 381 01 00	1.00	SFD	C	1.00	1.00	\$0.00	\$0.00	Johnson Dale M&Gail K
267 381 02 00	1.00	SFD	C	1.00	1.00	\$0.00	\$0.00	Ewing Thomas&Deborah Family Trust 02-18-91
267 381 03 00	1.00	SFD	C	1.00	1.00	\$0.00	\$0.00	Kwan Thomas J T&Shirley S Revocable Trust 03-20-15
267 381 04 00	1.00	SFD	C	1.00	1.00	\$0.00	\$0.00	Miller Family Survivors Trust 09-23-99
267 381 05 00	1.00	SFD	C	1.00	1.00	\$0.00	\$0.00	Tilford Toby&Juliet
267 381 06 00	1.00	SFD	C	1.00	1.00	\$0.00	\$0.00	Yan Wai M
267 381 07 00	1.00	SFD	C	1.00	1.00	\$0.00	\$0.00	Stelzner Family Trust 05-13-03
267 381 08 00	1.00	SFD	C	1.00	1.00	\$0.00	\$0.00	Whitney Family Trust 06-09-05
267 381 09 00	1.00	SFD	C	1.00	1.00	\$0.00	\$0.00	Black Mountain Ranch L L C
267 381 10 00	1.00	SFD	C	1.00	1.00	\$0.00	\$0.00	Black Mountain Ranch L L C
267 381 11 00	1.00	SFD	C	1.00	1.00	\$0.00	\$0.00	Zakov Kamen&Rita
267 381 12 00	1.00	SFD	C	1.00	1.00	\$0.00	\$0.00	Caputo Family Trust 05-29-97
267 381 13 00	1.00	SFD	C	1.00	1.00	\$0.00	\$0.00	Mcginis Russell&Karen
267 381 14 00	1.00	SFD	C	1.00	1.00	\$0.00	\$0.00	Mcguire Jonathan W&Marla N
267 381 15 00	1.00	SFD	C	1.00	1.00	\$0.00	\$0.00	Orlansky Inter Vivos Trust 01-03-86
267 381 16 00	1.00	SFD	C	1.00	1.00	\$0.00	\$0.00	Strauss Richard&Sherry
267 381 17 00	1.00	SFD	C	1.00	1.00	\$0.00	\$0.00	Maranian Raffi P&Brandy H

EXHIBIT C - Assessment Roll (Fiscal Year 2017)
Black Mountain Ranch North Maintenance Assessment District

Parcel Number	Acres/ Units ⁽¹⁾	Land Use Code ⁽²⁾	Zone	Land Use Factor ⁽²⁾	Total EBUs	Unit Cost (\$/Ebu)	FY 2017 ⁽³⁾ Assessment	Owner Name
267 381 18 00	1.00	SFD	C	1.00	1.00	\$0.00	\$0.00	Clift John W&Kathryn Revocable 2014 Trust 01-31-14
267 381 19 00	1.00	SFD	C	1.00	1.00	\$0.00	\$0.00	Oliver John T&Beverly A
267 381 20 00	1.00	SFD	C	1.00	1.00	\$0.00	\$0.00	Konzen-Ormsby Trust 09-10-10
267 381 21 00	1.00	SFD	C	1.00	1.00	\$0.00	\$0.00	Conaty Family Trust
267 381 22 00	1.00	SFD	C	1.00	1.00	\$0.00	\$0.00	Black Mountain Ranch L L C
267 381 23 00	1.00	SFD	C	1.00	1.00	\$0.00	\$0.00	Black Mountain Ranch L L C
267 381 24 00	1.00	SFD	C	1.00	1.00	\$0.00	\$0.00	Black Mountain Ranch L L C
267 381 25 00	1.00	SFD	C	1.00	1.00	\$0.00	\$0.00	Black Mountain Ranch L L C
267 381 26 00	1.00	SFD	C	1.00	1.00	\$0.00	\$0.00	Black Mountain Ranch L L C
267 381 27 00	1.00	SFD	C	1.00	1.00	\$0.00	\$0.00	Black Mountain Ranch L L C
267 381 28 00	1.00	SFD	C	1.00	1.00	\$0.00	\$0.00	Black Mountain Ranch L L C
267 381 29 00	1.00	SFD	C	1.00	1.00	\$0.00	\$0.00	Black Mountain Ranch L L C
267 381 30 00	1.00	SFD	C	1.00	1.00	\$0.00	\$0.00	Pollack Family Trust 05-28-87
267 381 31 00	1.00	SFD	C	1.00	1.00	\$0.00	\$0.00	Oneal Ryan&Kimberly Family Trust
267 381 32 00	1.00	SFD	C	1.00	1.00	\$0.00	\$0.00	Hooker James T Family Trust 01-27-01
267 381 33 00	1.00	SFD	C	1.00	1.00	\$0.00	\$0.00	Glasgow Revocable Trust 04-04-07
267 381 34 00	1.00	SFD	C	1.00	1.00	\$0.00	\$0.00	Black Mountain Ranch L L C
267 381 35 00	1.00	SFD	C	1.00	1.00	\$0.00	\$0.00	Black Mountain Ranch L L C
267 381 36 00	1.00	SFD	C	1.00	1.00	\$0.00	\$0.00	Black Mountain Ranch L L C
267 381 37 00	0.17	OSP	C	0.00	0.00	\$0.00	\$0.00	Black Mountain Ranch L L C
267 381 38 00	3.79	OSP	C	0.00	0.00	\$0.00	\$0.00	Black Mountain Ranch L L C
267 381 39 00	2.23	STR	C	0.00	0.00	\$0.00	\$0.00	Delsur Community Assn
267 381 40 00	3.99	STR	C	0.00	0.00	\$0.00	\$0.00	Black Mountain Ranch L L C
267 400 01 00	1.00	SFD	E	1.00	1.00	\$0.00	\$0.00	Deforest Devin O
267 400 02 00	1.00	SFD	E	1.00	1.00	\$0.00	\$0.00	Ahmed Ilhamuddin&Mushtarin Wadina
267 400 03 00	1.00	SFD	E	1.00	1.00	\$0.00	\$0.00	Jannesari Saeid&Aramfard Mansoureh
267 400 04 00	1.00	SFD	E	1.00	1.00	\$0.00	\$0.00	Harikrishnan Venkatesh&Vadivelnaryanamurthy Priya
267 400 05 00	1.00	SFD	E	1.00	1.00	\$0.00	\$0.00	Brown&Quan Family Trust 08-01-06
267 400 06 00	1.00	SFD	E	1.00	1.00	\$0.00	\$0.00	Kudrimoti Abhijit&Marathe Padminee
267 400 07 00	1.00	SFD	E	1.00	1.00	\$0.00	\$0.00	Jiang Yuqiu&Teng Shutian
267 400 08 00	1.00	SFD	E	1.00	1.00	\$0.00	\$0.00	Aune Family Living Trust 04-01-14
267 400 09 00	1.00	SFD	E	1.00	1.00	\$0.00	\$0.00	Temple Jay L&Priscilla G
267 400 10 00	1.00	SFD	E	1.00	1.00	\$0.00	\$0.00	Lee Judy
267 400 11 00	1.00	SFD	E	1.00	1.00	\$0.00	\$0.00	Sekar Balaji&Natarajan Krithika
267 400 12 00	1.00	SFD	E	1.00	1.00	\$0.00	\$0.00	Bonslaver Mark D&Boyer Darcy E
267 400 13 00	1.00	SFD	E	1.00	1.00	\$0.00	\$0.00	Jaakkola Mikko&Niina Family 2013 Trust
267 400 14 00	1.00	SFD	E	1.00	1.00	\$0.00	\$0.00	Uhlenkott Craig&Nicole
267 400 15 00	1.00	SFD	E	1.00	1.00	\$0.00	\$0.00	Moore Grant A&Kari L
267 400 16 00	1.00	SFD	E	1.00	1.00	\$0.00	\$0.00	Rosevear Craig&Dalon Living Trust 04-07-14
267 400 17 00	1.00	SFD	E	1.00	1.00	\$0.00	\$0.00	Mertz Robert J&Pamela M
267 400 18 00	1.00	SFD	E	1.00	1.00	\$0.00	\$0.00	Hubbard/Marshall Family Revocable Trust 12-21-11
267 400 19 00	1.00	SFD	E	1.00	1.00	\$0.00	\$0.00	Rodewald Jeffrey D&Cinda L
267 400 20 00	1.00	SFD	E	1.00	1.00	\$0.00	\$0.00	Leedom Gregory J&Allison D
267 400 21 00	1.00	SFD	E	1.00	1.00	\$0.00	\$0.00	Perry Todd A&Kathleen A
267 400 22 00	1.00	SFD	E	1.00	1.00	\$0.00	\$0.00	Wendlandt Ryan&Heather
267 400 23 00	1.00	SFD	E	1.00	1.00	\$0.00	\$0.00	Cruden Robert A
267 400 24 00	1.00	SFD	E	1.00	1.00	\$0.00	\$0.00	Merrill Howard&Jacquelynn
267 400 25 00	1.00	SFD	E	1.00	1.00	\$0.00	\$0.00	Louis Dwayne M&Brandi L
267 400 26 00	1.00	SFD	E	1.00	1.00	\$0.00	\$0.00	Zhang Jianbo&Tang Chao
267 400 27 00	1.00	SFD	E	1.00	1.00	\$0.00	\$0.00	Bahmani Kambiz&Connery Colleen M
267 400 28 00	1.00	SFD	E	1.00	1.00	\$0.00	\$0.00	Patel Rakesh J&Urmisha R
267 400 29 00	1.00	SFD	E	1.00	1.00	\$0.00	\$0.00	Wenk Richard D Trust 03-20-14
267 400 30 00	1.00	SFD	E	1.00	1.00	\$0.00	\$0.00	Kwon Young&Jane Trust 09-09-13
267 400 31 00	1.00	SFD	E	1.00	1.00	\$0.00	\$0.00	Bradford-Vana Family Trust 06-01-12
267 400 32 00	1.00	SFD	E	1.00	1.00	\$0.00	\$0.00	Arunachalam Balaji&Counassegarane Prasenna L
267 400 33 00	1.00	SFD	E	1.00	1.00	\$0.00	\$0.00	Dellorfano Anthony E
267 400 34 00	1.00	SFD	E	1.00	1.00	\$0.00	\$0.00	Sutharsan Thirunathan&Jeyanthi
267 400 35 00	1.00	SFD	E	1.00	1.00	\$0.00	\$0.00	Jurado Glaser&Cynthia
267 400 36 00	1.00	SFD	E	1.00	1.00	\$0.00	\$0.00	Eghaneyan Qumars&Nadia

EXHIBIT C - Assessment Roll (Fiscal Year 2017)
Black Mountain Ranch North Maintenance Assessment District

Parcel Number	Acres/ Units ⁽¹⁾	Land Use Code ⁽²⁾	Zone	Land Use Factor ⁽²⁾	Total EBUs	Unit Cost (\$/Ebu)	FY 2017 ⁽³⁾ Assessment	Owner Name
267 400 37 00	1.00	SFD	E	1.00	1.00	\$0.00	\$0.00	Heidecker Joel D&Natalie R
267 400 38 00	1.00	SFD	E	1.00	1.00	\$0.00	\$0.00	Crossland-Secor Family Trust 04-29-11
267 400 39 00	1.00	SFD	E	1.00	1.00	\$0.00	\$0.00	Mettapalli Family Revocable Trust 11-15-13
267 400 40 00	1.00	SFD	E	1.00	1.00	\$0.00	\$0.00	Muendler Family Trust 06-15-12
267 400 41 00	1.00	SFD	E	1.00	1.00	\$0.00	\$0.00	Syed Mohammed M&Nasim Saima A
267 400 42 00	1.00	SFD	E	1.00	1.00	\$0.00	\$0.00	Flynn Patrick P&April R
267 400 43 00	1.00	SFD	E	1.00	1.00	\$0.00	\$0.00	Johnston Robert C&Christina P
267 400 44 00	1.00	SFD	E	1.00	1.00	\$0.00	\$0.00	Shi Ruofei&Guo Jing
267 400 45 00	1.00	SFD	E	1.00	1.00	\$0.00	\$0.00	Choi Michael J&Jaime D
267 400 46 00	1.00	SFD	E	1.00	1.00	\$0.00	\$0.00	Mayo Steven&Shefic Margaret
267 400 47 00	1.00	SFD	E	1.00	1.00	\$0.00	\$0.00	Odonnell Kelly V&Lisa E
267 400 48 00	1.00	SFD	E	1.00	1.00	\$0.00	\$0.00	Pinderski Eric&Soukahn
267 400 49 00	1.00	SFD	E	1.00	1.00	\$0.00	\$0.00	Fessenden James C&Allison H
267 400 50 00	1.00	SFD	E	1.00	1.00	\$0.00	\$0.00	Dundas Lisa G
267 400 51 00	1.00	SFD	E	1.00	1.00	\$0.00	\$0.00	Bradley Dustin A&Megan D
267 400 52 00	1.00	SFD	E	1.00	1.00	\$0.00	\$0.00	Schroeder Ryan D&Milena E
267 400 53 00	1.00	SFD	E	1.00	1.00	\$0.00	\$0.00	Wien Daniel P&Christensen Michelle A
267 400 54 00	1.00	SFD	E	1.00	1.00	\$0.00	\$0.00	Bertino Ces F&Rita
267 400 55 00	0.05	OSP	E	0.00	0.00	\$0.00	\$0.00	Del Sur Community Assn
267 400 56 00	0.15	OSP	E	0.00	0.00	\$0.00	\$0.00	Del Sur Community Assn
267 400 57 00	0.10	OSP	E	0.00	0.00	\$0.00	\$0.00	Del Sur Community Assn
267 401 01 00	1.00	SFD	E	1.00	1.00	\$0.00	\$0.00	Gu Xiaoping&Wu Qi
267 401 02 00	1.00	SFD	E	1.00	1.00	\$0.00	\$0.00	Chao Jianhua
267 401 03 00	1.00	SFD	E	1.00	1.00	\$0.00	\$0.00	Kedar Ehud&Yarritu Elena
267 401 04 00	1.00	SFD	E	1.00	1.00	\$0.00	\$0.00	Smith Jason
267 401 05 00	1.00	SFD	E	1.00	1.00	\$0.00	\$0.00	Woods David J&Sandy W
267 401 06 00	1.00	SFD	E	1.00	1.00	\$0.00	\$0.00	Schneringer Family Trust 11-20-14
267 401 07 00	1.00	SFD	E	1.00	1.00	\$0.00	\$0.00	Kan Andrew K&Ha Jimin
267 401 08 00	1.00	SFD	E	1.00	1.00	\$0.00	\$0.00	Martinez Svetlana
267 401 09 00	1.00	SFD	E	1.00	1.00	\$0.00	\$0.00	Pernicano Brett&Lauren
267 401 10 00	1.00	SFD	E	1.00	1.00	\$0.00	\$0.00	Kim Han Seung&Helen H
267 401 11 00	1.00	SFD	E	1.00	1.00	\$0.00	\$0.00	Dang Philippe Khanh&Vu Nga Thi
267 401 12 00	1.00	SFD	E	1.00	1.00	\$0.00	\$0.00	Bond Revocable Trust 11-03-15
267 401 13 00	1.00	SFD	E	1.00	1.00	\$0.00	\$0.00	Thakkar Snehakumar K&Ashabahan S
267 401 14 00	1.00	SFD	E	1.00	1.00	\$0.00	\$0.00	Chong In Suk&Yoo Young Eun
267 401 15 00	1.00	SFD	E	1.00	1.00	\$0.00	\$0.00	Chong Jesus&Carina
267 401 16 00	1.00	SFD	E	1.00	1.00	\$0.00	\$0.00	Lebrun Raymond&Kristina
267 401 17 00	1.00	SFD	E	1.00	1.00	\$0.00	\$0.00	Boreddy Jayaprakash R&Vaddireddy Sulochana R
267 401 18 00	1.00	SFD	E	1.00	1.00	\$0.00	\$0.00	Thoziyoor Shyamkumar&Vadakkumkooor Subha
267 401 19 00	1.00	SFD	E	1.00	1.00	\$0.00	\$0.00	Wolf Donald T&Kim B
267 401 20 00	1.00	SFD	E	1.00	1.00	\$0.00	\$0.00	8484 Ednaly Lane L L C
267 401 21 00	1.00	SFD	E	1.00	1.00	\$0.00	\$0.00	Jong Jun Ho&Joan
267 401 22 00	1.00	SFD	E	1.00	1.00	\$0.00	\$0.00	Le Truong-Giang&Dorothy S
267 401 23 00	1.00	SFD	E	1.00	1.00	\$0.00	\$0.00	Jones-Storey Kelly&Garcia-Jones Silvia
267 401 24 00	1.00	SFD	E	1.00	1.00	\$0.00	\$0.00	Tubati Srikanth&Kondapi Sai P
267 401 25 00	1.00	SFD	E	1.00	1.00	\$0.00	\$0.00	C L M Trust
267 401 26 00	1.00	SFD	E	1.00	1.00	\$0.00	\$0.00	Crossgrove Jarrett R&Tiffany
267 401 27 00	1.00	SFD	E	1.00	1.00	\$0.00	\$0.00	Bunsold Robert A&Kristin K
267 401 28 00	1.00	SFD	E	1.00	1.00	\$0.00	\$0.00	Chu-Pham Trust 06-21-11
267 401 29 00	1.00	SFD	E	1.00	1.00	\$0.00	\$0.00	Tran-Ho Family Trust 10-02-14
267 401 30 00	1.00	SFD	E	1.00	1.00	\$0.00	\$0.00	Zimmer Scott A&Julianne
267 401 31 00	1.00	SFD	E	1.00	1.00	\$0.00	\$0.00	Dong Dalei&Choi Sera
267 401 32 00	1.00	SFD	E	1.00	1.00	\$0.00	\$0.00	Warner John M&Pandora H
267 401 33 00	1.00	SFD	E	1.00	1.00	\$0.00	\$0.00	Varga Gerald
267 401 34 00	1.00	SFD	E	1.00	1.00	\$0.00	\$0.00	Czyszczonek Thomas M&Gail
267 401 35 00	1.00	SFD	E	1.00	1.00	\$0.00	\$0.00	Petersen Andrew&Laura
267 401 36 00	1.00	SFD	E	1.00	1.00	\$0.00	\$0.00	Shih Family Trust 12-10-13
267 401 37 00	1.00	SFD	E	1.00	1.00	\$0.00	\$0.00	Hartmann Scott&Sharon Trust 04-26-08
267 401 38 00	1.00	SFD	E	1.00	1.00	\$0.00	\$0.00	Grothe Paul&Traci

EXHIBIT C - Assessment Roll (Fiscal Year 2017)
Black Mountain Ranch North Maintenance Assessment District

Parcel Number	Acres/ Units ⁽¹⁾	Land Use Code ⁽²⁾	Zone	Land Use Factor ⁽²⁾	Total EBUs	Unit Cost (\$/EUBU)	FY 2017 ⁽³⁾ Assessment	Owner Name
267 401 39 00	1.00	SFD	E	1.00	1.00	\$0.00	\$0.00	Jha Somesh&Jaya
267 401 40 00	1.00	SFD	E	1.00	1.00	\$0.00	\$0.00	Tsang Brian&Matsumoto Sandra
267 401 41 00	1.00	SFD	E	1.00	1.00	\$0.00	\$0.00	Smith K B Family Trust 06-26-13
267 401 42 00	1.00	SFD	E	1.00	1.00	\$0.00	\$0.00	Huang Tao&Zhang Shu Juan
267 401 43 00	1.00	SFD	E	1.00	1.00	\$0.00	\$0.00	Davies John&Bonarrigo Donna
267 401 44 00	1.00	SFD	E	1.00	1.00	\$0.00	\$0.00	Fonss Family Trust 01-04-13
267 401 45 00	1.00	SFD	E	1.00	1.00	\$0.00	\$0.00	Kuhnert Norbert K&Margaret J
267 401 46 00	1.00	SFD	E	1.00	1.00	\$0.00	\$0.00	Iraninejad Family Trust 11-21-07
267 401 47 00	1.00	SFD	E	1.00	1.00	\$0.00	\$0.00	Zhang Guoqing&Fan Jin
267 401 48 00	1.00	SFD	E	1.00	1.00	\$0.00	\$0.00	Itakura Nobuyasu R&Mai Pham
267 401 49 00	1.00	SFD	E	1.00	1.00	\$0.00	\$0.00	Devalaraju Phalguna&Rangaraju Kirthi
267 401 50 00	1.00	SFD	E	1.00	1.00	\$0.00	\$0.00	Lee Debra
267 401 51 00	1.00	SFD	E	1.00	1.00	\$0.00	\$0.00	Farrell Christopher J&Hansel Donna E
267 401 52 00	1.00	SFD	E	1.00	1.00	\$0.00	\$0.00	Mccallum Ian&Diane
267 401 53 00	1.00	SFD	E	1.00	1.00	\$0.00	\$0.00	Cline Brian K&Kristin C
267 401 54 00	1.00	SFD	E	1.00	1.00	\$0.00	\$0.00	Jenkins Kira C
267 401 55 00	1.00	SFD	E	1.00	1.00	\$0.00	\$0.00	Fischbein Family Survivors Trust 04-20-97
267 401 56 00	1.00	SFD	E	1.00	1.00	\$0.00	\$0.00	Reed Charles D Jr&Judith
267 401 57 00	1.00	SFD	E	1.00	1.00	\$0.00	\$0.00	Blalock Misty
267 401 58 00	1.00	SFD	E	1.00	1.00	\$0.00	\$0.00	Howell Revocable Trust 02-16-12
267 401 59 00	1.00	SFD	E	1.00	1.00	\$0.00	\$0.00	Mcguire Christopher H&Nicole R
267 401 60 00	1.00	SFD	E	1.00	1.00	\$0.00	\$0.00	Amble Christopher S&Jennifer J
267 401 61 00	1.00	SFD	E	1.00	1.00	\$0.00	\$0.00	Gillespie Living Trust 06-10-99
267 401 62 00	1.00	SFD	E	1.00	1.00	\$0.00	\$0.00	Abalos Michael P&Mary J L
267 401 63 00	1.00	SFD	E	1.00	1.00	\$0.00	\$0.00	Alejandro Lawrence&Linh M
267 401 64 00	1.00	SFD	E	1.00	1.00	\$0.00	\$0.00	Salmen Christopher J&Cheryl G Family Trust 07-13-11
267 401 65 00	0.13	OSP	E	0.00	0.00	\$0.00	\$0.00	Del Sur Community Assn
267 401 66 00	0.02	OSP	E	0.00	0.00	\$0.00	\$0.00	Del Sur Community Assn
267 401 67 00	0.05	OSP	E	0.00	0.00	\$0.00	\$0.00	Del Sur Community Assn
267 401 68 00	0.08	OSP	E	0.00	0.00	\$0.00	\$0.00	Del Sur Community Assn
267 401 69 00	0.11	OSP	E	0.00	0.00	\$0.00	\$0.00	Del Sur Community Assn
267 401 70 00	0.05	OSP	E	0.00	0.00	\$0.00	\$0.00	Del Sur Community Assn
267 401 71 00	0.37	STR	E	0.00	0.00	\$0.00	\$0.00	Delsur Community Assn
267 401 72 00	0.08	OSP	E	0.00	0.00	\$0.00	\$0.00	Del Sur Community Assn
267 401 73 00	0.02	OSP	E	0.00	0.00	\$0.00	\$0.00	Del Sur Community Assn
267 401 74 00	0.05	OSP	E	0.00	0.00	\$0.00	\$0.00	Del Sur Community Assn
267 402 01 00	1.00	SFD	E	1.00	1.00	\$0.00	\$0.00	Severson Family Trust 09-14-12
267 402 02 00	1.00	SFD	E	1.00	1.00	\$0.00	\$0.00	Sen Diparjan&Keri
267 402 03 00	1.00	SFD	E	1.00	1.00	\$0.00	\$0.00	Sinnokrot Mohammed&Saleh Ola
267 402 04 00	1.00	SFD	E	1.00	1.00	\$0.00	\$0.00	Nazif Omar A&Katherine E
267 402 05 00	1.00	SFD	E	1.00	1.00	\$0.00	\$0.00	Gross James F&Erin L
267 402 06 00	1.00	SFD	E	1.00	1.00	\$0.00	\$0.00	Sourkes Jonathan M&Sheryl
267 402 07 00	1.00	SFD	E	1.00	1.00	\$0.00	\$0.00	Renner Cullen&Stephanie A
267 402 08 00	1.00	SFD	E	1.00	1.00	\$0.00	\$0.00	Davis Christopher J&Karen F
267 402 09 00	1.00	SFD	E	1.00	1.00	\$0.00	\$0.00	Margozewitz John&Heather Revocable 2011 Trust 12-15-11
267 402 10 00	1.00	SFD	E	1.00	1.00	\$0.00	\$0.00	Dyer Kevin&Akemi B
267 402 11 00	1.00	SFD	E	1.00	1.00	\$0.00	\$0.00	Iranitehrani Mohammad&Tehrani Laura
267 402 12 00	1.00	SFD	E	1.00	1.00	\$0.00	\$0.00	Weatherford Yvonne 2001 Trust
267 402 13 00	1.00	SFD	E	1.00	1.00	\$0.00	\$0.00	Rubanyi Gabor&Edith
267 402 14 00	1.00	SFD	E	1.00	1.00	\$0.00	\$0.00	Thinnes Katharina C
267 402 15 00	1.00	SFD	E	1.00	1.00	\$0.00	\$0.00	Thiessen Rose M
267 402 16 00	1.00	SFD	E	1.00	1.00	\$0.00	\$0.00	Zhang Fang
267 402 17 00	1.00	SFD	E	1.00	1.00	\$0.00	\$0.00	Yao Charles C
267 402 18 00	1.00	SFD	E	1.00	1.00	\$0.00	\$0.00	Beckman Family Survivors Trust 11-14-90
267 402 19 00	1.00	SFD	E	1.00	1.00	\$0.00	\$0.00	Conrad Family Trust 04-03-89
267 402 20 00	1.00	SFD	E	1.00	1.00	\$0.00	\$0.00	Chow Shein-Chung&Pong Annpey
267 402 21 00	1.00	SFD	E	1.00	1.00	\$0.00	\$0.00	Deissl-Gibbs Jason T&Cira
267 402 22 00	1.00	SFD	E	1.00	1.00	\$0.00	\$0.00	Conner Gregory&Veronica Trust 11-19-07
267 402 23 00	1.00	SFD	E	1.00	1.00	\$0.00	\$0.00	Brookfield D S 51 L L C

EXHIBIT C - Assessment Roll (Fiscal Year 2017)
Black Mountain Ranch North Maintenance Assessment District

Parcel Number	Acres/ Units ⁽¹⁾	Land Use Code ⁽²⁾	Zone	Land Use Factor ⁽²⁾	Total EBUs	Unit Cost (\$/EUBU)	FY 2017 ⁽³⁾ Assessment	Owner Name
267 402 24 00	1.00	SFD	E	1.00	1.00	\$0.00	\$0.00	Schramm Walter&Hanna
267 402 25 00	1.00	SFD	E	1.00	1.00	\$0.00	\$0.00	Digiacom Family Trust 03-15-94
267 402 26 00	0.32	STR	E	0.00	0.00	\$0.00	\$0.00	Brookfield D S 51 L L C
267 402 27 00	3.83	OSP	E	0.00	0.00	\$0.00	\$0.00	Del Sur Community Assn
267 402 28 00	0.12	STR	E	0.00	0.00	\$0.00	\$0.00	Brookfield D S 51 L L C
267 402 29 00	0.20	OSP	E	0.00	0.00	\$0.00	\$0.00	Black Mountain Ranch L L C
267 402 30 00	0.13	STR	E	0.00	0.00	\$0.00	\$0.00	Del Sur Community Assn
267 403 02 00	0.31	OSP	E	0.00	0.00	\$0.00	\$0.00	Del Sur Community Assn
267 403 03 00	1.01	PKU	E	0.50	0.51	\$0.00	\$0.00	Black Mountain Ranch L L C
267 403 04 00	4.73	OSP	E	0.00	0.00	\$0.00	\$0.00	Black Mountain Ranch L L C
267 403 05 01	1.00	CND	E	0.70	0.70	\$0.00	\$0.00	Schweichler Jeffrey&Pamela
267 403 05 02	1.00	CND	E	0.70	0.70	\$0.00	\$0.00	Casanova Cassandra J
267 403 05 03	1.00	CND	E	0.70	0.70	\$0.00	\$0.00	Iyer Ashish&Shinde Shweta
267 403 05 04	1.00	CND	E	0.70	0.70	\$0.00	\$0.00	Knudsen Arvind&Anette B
267 403 05 05	1.00	CND	E	0.70	0.70	\$0.00	\$0.00	Harriss Catherine M H Living Trust 11-07-13
267 403 05 06	1.00	CND	E	0.70	0.70	\$0.00	\$0.00	Ditzhazy Noel R
267 403 05 07	1.00	CND	E	0.70	0.70	\$0.00	\$0.00	Huniu Aaron D&Susan M
267 403 05 08	1.00	CND	E	0.70	0.70	\$0.00	\$0.00	Hughart Nicholas&Amber K
267 403 05 09	1.00	CND	E	0.70	0.70	\$0.00	\$0.00	Dunbar James R
267 403 05 10	1.00	CND	E	0.70	0.70	\$0.00	\$0.00	Mcgloughlin Michael&Gwozdz Renata
267 403 06 01	1.00	CND	E	0.70	0.70	\$0.00	\$0.00	Barnes Kent M&Robin R Living Trust 05-31-13
267 403 06 02	1.00	CND	E	0.70	0.70	\$0.00	\$0.00	Obrien David J&Donna C C
267 403 06 03	1.00	CND	E	0.70	0.70	\$0.00	\$0.00	Capule Ronald&Templo-Capule Marie
267 403 06 04	1.00	CND	E	0.70	0.70	\$0.00	\$0.00	Saad Ashraf A
267 403 06 05	1.00	CND	E	0.70	0.70	\$0.00	\$0.00	Kattamuri Subrahmanyam V&Gorugantu Sriya
267 403 06 06	1.00	CND	E	0.70	0.70	\$0.00	\$0.00	Kishen Kiran B
267 403 06 07	1.00	CND	E	0.70	0.70	\$0.00	\$0.00	Arbogast G Tomi
267 403 06 08	1.00	CND	E	0.70	0.70	\$0.00	\$0.00	Craft Christopher L
267 403 06 09	1.00	CND	E	0.70	0.70	\$0.00	\$0.00	Johnson Tyler D&Allison E
267 403 06 10	1.00	CND	E	0.70	0.70	\$0.00	\$0.00	Wiglesworth Robert T&Raquel M
267 403 07 01	1.00	CND	E	0.70	0.70	\$0.00	\$0.00	Cavender Aleksandra
267 403 07 02	1.00	CND	E	0.70	0.70	\$0.00	\$0.00	Rajput Akhil&Chandrasekhar Anjana
267 403 07 03	1.00	CND	E	0.70	0.70	\$0.00	\$0.00	Huang Chun Ming
267 403 07 04	1.00	CND	E	0.70	0.70	\$0.00	\$0.00	Zhao Xin&Sun Xiaojing
267 403 07 05	1.00	CND	E	0.70	0.70	\$0.00	\$0.00	Mao Jia
267 403 07 06	1.00	CND	E	0.70	0.70	\$0.00	\$0.00	Marudharaju Ramesh&Subramani Deepalakshmi
267 403 07 07	1.00	CND	E	0.70	0.70	\$0.00	\$0.00	Nichols Michael W&Christina
267 403 07 08	1.00	CND	E	0.70	0.70	\$0.00	\$0.00	Colangelo Rosamaria
267 403 07 09	1.00	CND	E	0.70	0.70	\$0.00	\$0.00	Kemper Gregory R Jr
267 403 07 10	1.00	CND	E	0.70	0.70	\$0.00	\$0.00	Mcafee Allan M&Charissa K
267 403 08 01	1.00	CND	E	0.70	0.70	\$0.00	\$0.00	Roeder Eric&Hilary
267 403 08 02	1.00	CND	E	0.70	0.70	\$0.00	\$0.00	Kemmerrer Kevin&Chelsea C
267 403 08 03	1.00	CND	E	0.70	0.70	\$0.00	\$0.00	Dean Joshua W&Sarah E
267 403 08 04	1.00	CND	E	0.70	0.70	\$0.00	\$0.00	Koenig Grant M&Sallie A
267 403 08 05	1.00	CND	E	0.70	0.70	\$0.00	\$0.00	Treacy Gerald B&Joyce M
267 403 08 06	1.00	CND	E	0.70	0.70	\$0.00	\$0.00	Salehizadeh Kian&Flaherty Stephanie M
267 403 08 07	1.00	CND	E	0.70	0.70	\$0.00	\$0.00	Hale Annie Hung-En&Aaron Dean Revocable Trust 02-25-06
267 403 08 08	1.00	CND	E	0.70	0.70	\$0.00	\$0.00	Strachan Jeffrey&Michelle
267 403 08 09	1.00	CND	E	0.70	0.70	\$0.00	\$0.00	Fang Alfredo A&Evangeline O
267 403 08 10	1.00	CND	E	0.70	0.70	\$0.00	\$0.00	Trausch Richard L&Jan M
267 403 09 01	1.00	CND	E	0.70	0.70	\$0.00	\$0.00	Chase Lawrence
267 403 09 02	1.00	CND	E	0.70	0.70	\$0.00	\$0.00	Mazur Daniel J
267 403 09 03	1.00	CND	E	0.70	0.70	\$0.00	\$0.00	Kim In Chull
267 403 09 04	1.00	CND	E	0.70	0.70	\$0.00	\$0.00	Fitch Donald R&Insun A
267 403 09 05	1.00	CND	E	0.70	0.70	\$0.00	\$0.00	Reed Kevin B&Rebecca L
267 403 09 06	1.00	CND	E	0.70	0.70	\$0.00	\$0.00	Diverde Nicholas&Shannon Family 2007 Trust
267 403 10 01	1.00	CND	E	0.70	0.70	\$0.00	\$0.00	Christinson Lucas&Marisol
267 403 10 02	1.00	CND	E	0.70	0.70	\$0.00	\$0.00	Vuong Henry&Allyann Q
267 403 10 03	1.00	CND	E	0.70	0.70	\$0.00	\$0.00	Wozney Dean E&Catherine H

EXHIBIT C - Assessment Roll (Fiscal Year 2017)
Black Mountain Ranch North Maintenance Assessment District

Parcel Number	Acres/ Units ⁽¹⁾	Land Use Code ⁽²⁾	Zone	Land Use Factor ⁽²⁾	Total EBUs	Unit Cost (\$/EUBU)	FY 2017 ⁽³⁾ Assessment	Owner Name
267 403 10 04	1.00	CND	E	0.70	0.70	\$0.00	\$0.00	Maneri Thomas L Jr
267 403 10 05	1.00	CND	E	0.70	0.70	\$0.00	\$0.00	Pacific Asaad Trust 08-07-13
267 403 10 06	1.00	CND	E	0.70	0.70	\$0.00	\$0.00	Lucia Nicole M
267 403 10 07	1.00	CND	E	0.70	0.70	\$0.00	\$0.00	Barman Utpal&Borah Mridusmita
267 403 10 08	1.00	CND	E	0.70	0.70	\$0.00	\$0.00	Harrington Paula L
267 403 10 09	1.00	CND	E	0.70	0.70	\$0.00	\$0.00	Kim Jisung&Lora C
267 403 10 10	1.00	CND	E	0.70	0.70	\$0.00	\$0.00	Dionne Mark A
267 403 11 01	1.00	CND	E	0.70	0.70	\$0.00	\$0.00	Workman Timothy&Jena
267 403 11 02	1.00	CND	E	0.70	0.70	\$0.00	\$0.00	Shteremberg Sara Trust 06-20-14
267 403 11 03	1.00	CND	E	0.70	0.70	\$0.00	\$0.00	Kim William Jeongwoo&Lindsey Han
267 403 11 04	1.00	CND	E	0.70	0.70	\$0.00	\$0.00	Goswami Himanshu&Shah Himadri
267 403 11 05	1.00	CND	E	0.70	0.70	\$0.00	\$0.00	Berengolts Michael J&Orlee M
267 403 11 06	1.00	CND	E	0.70	0.70	\$0.00	\$0.00	Moore Travis D
267 403 11 07	1.00	CND	E	0.70	0.70	\$0.00	\$0.00	Diaz Kristie L
267 403 11 08	1.00	CND	E	0.70	0.70	\$0.00	\$0.00	Kashyap Gaurav
267 403 11 09	1.00	CND	E	0.70	0.70	\$0.00	\$0.00	Guimaraes Berenice C R
267 403 11 10	1.00	CND	E	0.70	0.70	\$0.00	\$0.00	Marsano Giovanni
267 403 12 01	1.00	CND	E	0.70	0.70	\$0.00	\$0.00	Samrith Chheat&Thanh
267 403 12 02	1.00	CND	E	0.70	0.70	\$0.00	\$0.00	Legaspi Jason
267 403 12 03	1.00	CND	E	0.70	0.70	\$0.00	\$0.00	Ramanandan Arvind&Ramachandra Anupama
267 403 12 04	1.00	CND	E	0.70	0.70	\$0.00	\$0.00	Samadder Amartya&Sarvani
267 470 01 00	1.00	SFD	A	1.00	1.00	\$0.00	\$0.00	Spic Del Sur L L C
267 470 02 00	1.00	SFD	A	1.00	1.00	\$0.00	\$0.00	Spic Del Sur L L C
267 470 03 00	1.00	SFD	A	1.00	1.00	\$0.00	\$0.00	Spic Del Sur L L C
267 470 04 00	1.00	SFD	A	1.00	1.00	\$0.00	\$0.00	Spic Del Sur L L C
267 470 05 00	1.00	SFD	A	1.00	1.00	\$0.00	\$0.00	Spic Del Sur L L C
267 470 06 00	1.00	SFD	A	1.00	1.00	\$0.00	\$0.00	Spic Del Sur L L C
267 470 07 00	1.00	SFD	A	1.00	1.00	\$0.00	\$0.00	Spic Del Sur L L C
267 470 08 00	1.00	SFD	A	1.00	1.00	\$0.00	\$0.00	Spic Del Sur L L C
267 470 09 00	1.00	SFD	A	1.00	1.00	\$0.00	\$0.00	Spic Del Sur L L C
267 470 10 00	1.00	SFD	A	1.00	1.00	\$0.00	\$0.00	Spic Del Sur L L C
267 470 11 00	1.00	SFD	A	1.00	1.00	\$0.00	\$0.00	Spic Del Sur L L C
267 470 12 00	1.00	SFD	A	1.00	1.00	\$0.00	\$0.00	Spic Del Sur L L C
267 470 13 00	1.00	SFD	A	1.00	1.00	\$0.00	\$0.00	Spic Del Sur L L C
267 470 14 00	1.00	SFD	A	1.00	1.00	\$0.00	\$0.00	Spic Del Sur L L C
267 470 15 00	1.00	SFD	A	1.00	1.00	\$0.00	\$0.00	Spic Del Sur L L C
267 470 16 00	1.00	SFD	A	1.00	1.00	\$0.00	\$0.00	Spic Del Sur L L C
267 470 17 00	1.00	SFD	A	1.00	1.00	\$0.00	\$0.00	Spic Del Sur L L C
267 470 18 00	1.00	SFD	A	1.00	1.00	\$0.00	\$0.00	Spic Del Sur L L C
267 470 19 00	1.00	SFD	A	1.00	1.00	\$0.00	\$0.00	Spic Del Sur L L C
267 470 20 00	1.00	SFD	A	1.00	1.00	\$0.00	\$0.00	Spic Del Sur L L C
267 470 21 00	1.00	SFD	A	1.00	1.00	\$0.00	\$0.00	Spic Del Sur L L C
267 470 22 00	1.00	SFD	A	1.00	1.00	\$0.00	\$0.00	Spic Del Sur L L C
267 470 23 00	1.00	SFD	A	1.00	1.00	\$0.00	\$0.00	Spic Del Sur L L C
267 470 24 00	1.00	SFD	A	1.00	1.00	\$0.00	\$0.00	Spic Del Sur L L C
267 470 25 00	1.00	SFD	A	1.00	1.00	\$0.00	\$0.00	Spic Del Sur L L C
267 470 26 00	1.00	SFD	A	1.00	1.00	\$0.00	\$0.00	Spic Del Sur L L C
267 470 27 00	1.00	SFD	A	1.00	1.00	\$0.00	\$0.00	Spic Del Sur L L C
267 470 28 00	1.00	SFD	A	1.00	1.00	\$0.00	\$0.00	Spic Del Sur L L C
267 470 29 00	1.00	SFD	A	1.00	1.00	\$0.00	\$0.00	Spic Del Sur L L C
267 470 30 00	1.00	SFD	A	1.00	1.00	\$0.00	\$0.00	Spic Del Sur L L C
267 470 31 00	15.00	SFD	A	1.00	15.00	\$0.00	\$0.00	Spic Del Sur L L C
267 470 32 00	20.33	STR	A	0.00	0.00	\$0.00	\$0.00	Spic Del Sur L L C
267 470 33 00	6.30	OSP	A	0.00	0.00	\$0.00	\$0.00	Spic Del Sur L L C
267 470 34 00	1.10	PKU	A	0.50	0.55	\$0.00	\$0.00	Spic Del Sur L L C
267 470 35 00	0.18	OSP	A	0.00	0.00	\$0.00	\$0.00	Spic Del Sur L L C
267 470 36 00	0.01	OSP	A	0.00	0.00	\$0.00	\$0.00	Spic Del Sur L L C
267 471 01 00	1.00	SFD	A	1.00	1.00	\$0.00	\$0.00	Spic Del Sur L L C
267 471 02 00	1.00	SFD	A	1.00	1.00	\$0.00	\$0.00	Spic Del Sur L L C

EXHIBIT C - Assessment Roll (Fiscal Year 2017)
Black Mountain Ranch North Maintenance Assessment District

Parcel Number	Acres/ Units ⁽¹⁾	Land Use Code ⁽²⁾	Zone	Land Use Factor ⁽²⁾	Total EBUs	Unit Cost (\$/Ebu)	FY 2017 ⁽³⁾ Assessment	Owner Name
267 471 03 00	1.00	SFD	A	1.00	1.00	\$0.00	\$0.00	Spic Del Sur L L C
267 471 04 00	1.00	SFD	A	1.00	1.00	\$0.00	\$0.00	Spic Del Sur L L C
267 471 05 00	1.00	SFD	A	1.00	1.00	\$0.00	\$0.00	Spic Del Sur L L C
267 471 06 00	1.00	SFD	A	1.00	1.00	\$0.00	\$0.00	Spic Del Sur L L C
267 471 07 00	1.00	SFD	A	1.00	1.00	\$0.00	\$0.00	Spic Del Sur L L C
267 471 08 00	1.00	SFD	A	1.00	1.00	\$0.00	\$0.00	Spic Del Sur L L C
267 471 09 00	1.00	SFD	A	1.00	1.00	\$0.00	\$0.00	Spic Del Sur L L C
267 471 10 00	1.00	SFD	A	1.00	1.00	\$0.00	\$0.00	Spic Del Sur L L C
267 471 11 00	1.00	SFD	A	1.00	1.00	\$0.00	\$0.00	Spic Del Sur L L C
267 471 12 00	1.00	SFD	A	1.00	1.00	\$0.00	\$0.00	Spic Del Sur L L C
267 471 13 00	1.00	SFD	A	1.00	1.00	\$0.00	\$0.00	Spic Del Sur L L C
267 471 14 00	1.00	SFD	A	1.00	1.00	\$0.00	\$0.00	Spic Del Sur L L C
267 471 15 00	1.00	SFD	A	1.00	1.00	\$0.00	\$0.00	Spic Del Sur L L C
267 471 16 00	1.00	SFD	A	1.00	1.00	\$0.00	\$0.00	Spic Del Sur L L C
267 471 17 00	1.00	SFD	A	1.00	1.00	\$0.00	\$0.00	Spic Del Sur L L C
267 471 18 00	1.00	SFD	A	1.00	1.00	\$0.00	\$0.00	Spic Del Sur L L C
267 471 19 00	1.00	SFD	A	1.00	1.00	\$0.00	\$0.00	Spic Del Sur L L C
267 471 20 00	1.00	SFD	A	1.00	1.00	\$0.00	\$0.00	Spic Del Sur L L C
267 471 21 00	1.00	SFD	A	1.00	1.00	\$0.00	\$0.00	Spic Del Sur L L C
267 471 22 00	1.00	SFD	A	1.00	1.00	\$0.00	\$0.00	Spic Del Sur L L C
267 471 23 00	1.00	SFD	A	1.00	1.00	\$0.00	\$0.00	Spic Del Sur L L C
267 471 24 00	1.00	SFD	A	1.00	1.00	\$0.00	\$0.00	Spic Del Sur L L C
267 471 25 00	1.00	SFD	A	1.00	1.00	\$0.00	\$0.00	Spic Del Sur L L C
267 471 26 00	1.00	SFD	A	1.00	1.00	\$0.00	\$0.00	Spic Del Sur L L C
267 471 27 00	1.00	SFD	A	1.00	1.00	\$0.00	\$0.00	Spic Del Sur L L C
267 471 28 00	1.00	SFD	A	1.00	1.00	\$0.00	\$0.00	Spic Del Sur L L C
267 471 29 00	1.00	SFD	A	1.00	1.00	\$0.00	\$0.00	Spic Del Sur L L C
267 471 30 00	1.00	SFD	A	1.00	1.00	\$0.00	\$0.00	Spic Del Sur L L C
267 471 31 00	1.00	SFD	A	1.00	1.00	\$0.00	\$0.00	Spic Del Sur L L C
267 471 32 00	1.00	SFD	A	1.00	1.00	\$0.00	\$0.00	Spic Del Sur L L C
267 471 33 00	1.00	SFD	A	1.00	1.00	\$0.00	\$0.00	Spic Del Sur L L C
267 471 34 00	1.00	SFD	A	1.00	1.00	\$0.00	\$0.00	Spic Del Sur L L C
267 471 35 00	1.00	SFD	A	1.00	1.00	\$0.00	\$0.00	Spic Del Sur L L C
267 471 36 00	1.00	SFD	A	1.00	1.00	\$0.00	\$0.00	Spic Del Sur L L C
267 471 37 00	1.00	SFD	A	1.00	1.00	\$0.00	\$0.00	Spic Del Sur L L C
267 471 38 00	1.00	SFD	A	1.00	1.00	\$0.00	\$0.00	Spic Del Sur L L C
267 471 39 00	1.00	SFD	A	1.00	1.00	\$0.00	\$0.00	Spic Del Sur L L C
267 471 40 00	1.00	SFD	A	1.00	1.00	\$0.00	\$0.00	Spic Del Sur L L C
267 471 41 00	1.00	SFD	A	1.00	1.00	\$0.00	\$0.00	Spic Del Sur L L C
267 471 42 00	1.00	SFD	A	1.00	1.00	\$0.00	\$0.00	Spic Del Sur L L C
267 471 43 00	1.00	SFD	A	1.00	1.00	\$0.00	\$0.00	Spic Del Sur L L C
267 471 44 00	1.00	SFD	A	1.00	1.00	\$0.00	\$0.00	Spic Del Sur L L C
267 471 45 00	1.00	SFD	A	1.00	1.00	\$0.00	\$0.00	Spic Del Sur L L C
267 471 46 00	1.00	SFD	A	1.00	1.00	\$0.00	\$0.00	Spic Del Sur L L C
267 471 47 00	1.00	SFD	A	1.00	1.00	\$0.00	\$0.00	Spic Del Sur L L C
267 471 48 00	1.00	SFD	A	1.00	1.00	\$0.00	\$0.00	Spic Del Sur L L C
267 471 49 00	1.00	SFD	A	1.00	1.00	\$0.00	\$0.00	Spic Del Sur L L C
267 471 50 00	1.00	SFD	A	1.00	1.00	\$0.00	\$0.00	Spic Del Sur L L C
267 471 51 00	1.00	SFD	A	1.00	1.00	\$0.00	\$0.00	Spic Del Sur L L C
267 471 52 00	1.00	SFD	A	1.00	1.00	\$0.00	\$0.00	Spic Del Sur L L C
267 471 53 00	1.00	SFD	A	1.00	1.00	\$0.00	\$0.00	Spic Del Sur L L C
267 471 54 00	1.00	SFD	A	1.00	1.00	\$0.00	\$0.00	Spic Del Sur L L C
267 471 55 00	1.00	SFD	A	1.00	1.00	\$0.00	\$0.00	Spic Del Sur L L C
267 471 56 00	1.00	SFD	A	1.00	1.00	\$0.00	\$0.00	Spic Del Sur L L C
267 471 57 00	1.00	SFD	A	1.00	1.00	\$0.00	\$0.00	Spic Del Sur L L C
267 471 58 00	1.00	SFD	A	1.00	1.00	\$0.00	\$0.00	Spic Del Sur L L C
267 471 59 00	1.00	SFD	A	1.00	1.00	\$0.00	\$0.00	Spic Del Sur L L C
267 471 60 00	1.00	SFD	A	1.00	1.00	\$0.00	\$0.00	Spic Del Sur L L C
267 471 61 00	1.00	SFD	A	1.00	1.00	\$0.00	\$0.00	Spic Del Sur L L C

EXHIBIT C - Assessment Roll (Fiscal Year 2017)
Black Mountain Ranch North Maintenance Assessment District

Parcel Number	Acres/ Units ⁽¹⁾	Land Use Code ⁽²⁾	Zone	Land Use Factor ⁽²⁾	Total EBUs	Unit Cost (\$/Ebu)	FY 2017 ⁽³⁾ Assessment	Owner Name
267 471 62 00	6.00	SFD	A	1.00	6.00	\$0.00	\$0.00	Spic Del Sur L L C
267 471 63 00	15.00	SFD	A	1.00	15.00	\$0.00	\$0.00	Spic Del Sur L L C
267 471 64 00	0.97	OSP	A	0.00	0.00	\$0.00	\$0.00	Spic Del Sur L L C
267 471 65 00	0.02	OSP	A	0.00	0.00	\$0.00	\$0.00	Spic Del Sur L L C
267 471 66 00	0.01	OSP	A	0.00	0.00	\$0.00	\$0.00	Spic Del Sur L L C
267 471 67 00	0.01	OSP	A	0.00	0.00	\$0.00	\$0.00	Spic Del Sur L L C
267 471 68 00	0.23	PKU	A	0.50	0.12	\$0.00	\$0.00	Spic Del Sur L L C
267 472 01 00	1.00	SFD	A	1.00	1.00	\$0.00	\$0.00	Spic Del Sur L L C
267 472 02 00	1.00	SFD	A	1.00	1.00	\$0.00	\$0.00	Spic Del Sur L L C
267 472 03 00	1.00	SFD	A	1.00	1.00	\$0.00	\$0.00	Spic Del Sur L L C
267 472 04 00	1.00	SFD	A	1.00	1.00	\$0.00	\$0.00	Spic Del Sur L L C
267 472 05 00	1.00	SFD	A	1.00	1.00	\$0.00	\$0.00	Spic Del Sur L L C
267 472 06 00	1.00	SFD	A	1.00	1.00	\$0.00	\$0.00	Spic Del Sur L L C
267 472 07 00	1.00	SFD	A	1.00	1.00	\$0.00	\$0.00	Spic Del Sur L L C
267 472 08 00	1.00	SFD	A	1.00	1.00	\$0.00	\$0.00	Spic Del Sur L L C
267 472 09 00	1.00	SFD	A	1.00	1.00	\$0.00	\$0.00	Spic Del Sur L L C
267 472 10 00	1.00	SFD	A	1.00	1.00	\$0.00	\$0.00	Spic Del Sur L L C
267 472 11 00	1.00	SFD	A	1.00	1.00	\$0.00	\$0.00	Spic Del Sur L L C
267 472 12 00	1.00	SFD	A	1.00	1.00	\$0.00	\$0.00	Spic Del Sur L L C
267 472 13 00	1.00	SFD	A	1.00	1.00	\$0.00	\$0.00	Spic Del Sur L L C
267 472 14 00	1.00	SFD	A	1.00	1.00	\$0.00	\$0.00	Spic Del Sur L L C
267 472 15 00	1.00	SFD	A	1.00	1.00	\$0.00	\$0.00	Spic Del Sur L L C
267 472 16 00	1.00	SFD	A	1.00	1.00	\$0.00	\$0.00	Spic Del Sur L L C
267 472 17 00	1.00	SFD	A	1.00	1.00	\$0.00	\$0.00	Spic Del Sur L L C
267 472 18 00	1.00	SFD	A	1.00	1.00	\$0.00	\$0.00	Spic Del Sur L L C
267 472 19 00	1.00	SFD	A	1.00	1.00	\$0.00	\$0.00	Spic Del Sur L L C
267 472 20 00	1.00	SFD	A	1.00	1.00	\$0.00	\$0.00	Spic Del Sur L L C
267 472 21 00	1.00	SFD	A	1.00	1.00	\$0.00	\$0.00	Spic Del Sur L L C
267 472 22 00	1.00	SFD	A	1.00	1.00	\$0.00	\$0.00	Spic Del Sur L L C
267 472 23 00	1.00	SFD	A	1.00	1.00	\$0.00	\$0.00	Spic Del Sur L L C
267 472 24 00	1.00	SFD	A	1.00	1.00	\$0.00	\$0.00	Spic Del Sur L L C
267 472 25 00	1.00	SFD	A	1.00	1.00	\$0.00	\$0.00	Spic Del Sur L L C
267 472 26 00	1.00	SFD	A	1.00	1.00	\$0.00	\$0.00	Spic Del Sur L L C
267 472 27 00	1.00	SFD	A	1.00	1.00	\$0.00	\$0.00	Spic Del Sur L L C
267 472 28 00	1.00	SFD	A	1.00	1.00	\$0.00	\$0.00	Spic Del Sur L L C
267 472 29 00	1.00	SFD	A	1.00	1.00	\$0.00	\$0.00	Spic Del Sur L L C
267 472 30 00	1.00	SFD	A	1.00	1.00	\$0.00	\$0.00	Spic Del Sur L L C
267 472 31 00	1.00	SFD	A	1.00	1.00	\$0.00	\$0.00	Spic Del Sur L L C
267 472 32 00	1.00	SFD	A	1.00	1.00	\$0.00	\$0.00	Spic Del Sur L L C
267 472 33 00	1.00	SFD	A	1.00	1.00	\$0.00	\$0.00	Spic Del Sur L L C
267 472 34 00	1.00	SFD	A	1.00	1.00	\$0.00	\$0.00	Spic Del Sur L L C
267 472 35 00	1.00	SFD	A	1.00	1.00	\$0.00	\$0.00	Spic Del Sur L L C
267 472 36 00	1.00	SFD	A	1.00	1.00	\$0.00	\$0.00	Spic Del Sur L L C
267 472 37 00	1.00	SFD	A	1.00	1.00	\$0.00	\$0.00	Spic Del Sur L L C
267 472 38 00	1.00	SFD	A	1.00	1.00	\$0.00	\$0.00	Spic Del Sur L L C
267 472 39 00	1.00	SFD	A	1.00	1.00	\$0.00	\$0.00	Spic Del Sur L L C
267 472 40 00	0.14	OSP	A	0.00	0.00	\$0.00	\$0.00	Spic Del Sur L L C
267 472 41 00	0.04	OSP	A	0.00	0.00	\$0.00	\$0.00	Spic Del Sur L L C
267 472 42 00	0.01	OSP	A	0.00	0.00	\$0.00	\$0.00	Spic Del Sur L L C
312 141 02 00	30.02	OSP	H	0.00	0.00	\$0.00	\$0.00	Spic Del Sur L L C
678 230 19 00	2.61	OSP	A	0.00	0.00	\$0.00	\$0.00	Black Mountain Ranch L L C
678 230 20 00	4.54	OSP	A	0.00	0.00	\$0.00	\$0.00	Black Mountain Ranch L L C
678 230 21 00	5.39	OSP	A	0.00	0.00	\$0.00	\$0.00	Black Mountain Ranch L L C
678 230 39 00	180.00	MFR	H	0.70	126.00	\$0.00	\$0.00	Fairbanks Commons C I C L P
678 230 40 00	40.05	EPS	H	5.00	200.25	\$0.00	\$0.00	Poway Unified School District
678 230 44 00	21.71	EPS	F	5.00	108.55	\$0.00	\$0.00	Poway Unified School District
678 230 46 00	3.53	COM	F	45.00	158.85	\$0.00	\$0.00	San Diego Gas&Electric Co
678 230 48 00	100.00	MFR	F	0.70	70.00	\$0.00	\$0.00	Fairbanks Square C I C Lp
678 230 49 00	146.17	OSP	A	0.00	0.00	\$0.00	\$0.00	Black Mountain Ranch L L C

EXHIBIT C - Assessment Roll (Fiscal Year 2017)
Black Mountain Ranch North Maintenance Assessment District

Parcel Number	Acres/ Units ⁽¹⁾	Land Use Code ⁽²⁾	Zone	Land Use Factor ⁽²⁾	Total EBUs	Unit Cost (\$/Ebu)	FY 2017 ⁽³⁾ Assessment	Owner Name
678 231 01 00	1.00	SFD	H	1.00	1.00	\$0.00	\$0.00	Benny Michael&Samar Y
678 231 02 00	1.00	SFD	H	1.00	1.00	\$0.00	\$0.00	Rosness Melissa M
678 231 03 00	1.00	SFD	H	1.00	1.00	\$0.00	\$0.00	Tang Yiwei&Deng Yun
678 231 04 00	1.00	SFD	H	1.00	1.00	\$0.00	\$0.00	Jones Dallas&Amy L
678 231 05 00	1.00	SFD	H	1.00	1.00	\$0.00	\$0.00	Maiti Banikumar&Manisha
678 231 06 00	1.00	SFD	H	1.00	1.00	\$0.00	\$0.00	Mondal Shyama P&Roy Rumela
678 231 07 00	1.00	SFD	H	1.00	1.00	\$0.00	\$0.00	Betts Shane R&Jennifer K
678 231 08 00	1.00	SFD	H	1.00	1.00	\$0.00	\$0.00	Mohan Ashwin&Venkataraman Priya M
678 231 09 00	1.00	SFD	H	1.00	1.00	\$0.00	\$0.00	Bhatia Amit&Sangar Samriti
678 231 10 00	1.00	SFD	H	1.00	1.00	\$0.00	\$0.00	Selvamani Rajasekaran&Kuppan Premalatha
678 231 11 00	1.00	SFD	H	1.00	1.00	\$0.00	\$0.00	Kumarswamy Preetham&Chakrasali Nagaveena
678 231 12 00	1.00	SFD	H	1.00	1.00	\$0.00	\$0.00	Chen Yi Tsang&Huang Hsin Yi
678 231 13 00	1.00	SFD	H	1.00	1.00	\$0.00	\$0.00	Moskowitz Larry J
678 231 14 00	1.00	SFD	H	1.00	1.00	\$0.00	\$0.00	Preece Todd W&Vejar-Preece Karla
678 231 15 00	1.00	SFD	H	1.00	1.00	\$0.00	\$0.00	Guan Rongchang&Cen Xiaoping
678 231 16 00	1.00	SFD	H	1.00	1.00	\$0.00	\$0.00	Vu Dale&Sandy
678 231 17 00	1.00	SFD	H	1.00	1.00	\$0.00	\$0.00	Spic Del Sur Llc
678 231 18 00	1.00	SFD	H	1.00	1.00	\$0.00	\$0.00	Spic Del Sur Llc
678 231 19 00	1.00	SFD	H	1.00	1.00	\$0.00	\$0.00	Spic Del Sur Llc
678 231 20 00	1.00	SFD	H	1.00	1.00	\$0.00	\$0.00	Spic Del Sur Llc
678 231 21 00	1.00	SFD	H	1.00	1.00	\$0.00	\$0.00	Spic Del Sur Llc
678 231 22 00	1.00	SFD	H	1.00	1.00	\$0.00	\$0.00	Spic Del Sur Llc
678 231 23 00	1.00	SFD	H	1.00	1.00	\$0.00	\$0.00	Spic Del Sur Llc
678 231 24 00	1.00	SFD	H	1.00	1.00	\$0.00	\$0.00	Spic Del Sur Llc
678 231 25 00	1.00	SFD	H	1.00	1.00	\$0.00	\$0.00	Kelley John&Cynthia
678 231 26 00	1.00	SFD	H	1.00	1.00	\$0.00	\$0.00	Park Dongmin&Ju Youngeun
678 231 27 00	1.00	SFD	H	1.00	1.00	\$0.00	\$0.00	Chen Yu&Ge Xuan
678 231 28 00	1.00	SFD	H	1.00	1.00	\$0.00	\$0.00	Cheng Zhongming&Liu Qiong
678 231 29 00	1.00	SFD	H	1.00	1.00	\$0.00	\$0.00	Spic Del Sur Llc
678 231 30 00	1.00	SFD	H	1.00	1.00	\$0.00	\$0.00	Bakes George D&Jean M
678 231 31 00	1.00	SFD	H	1.00	1.00	\$0.00	\$0.00	Venkatesan Sathish&Vijayaraghavan Vaidehi D
678 231 32 00	1.00	SFD	H	1.00	1.00	\$0.00	\$0.00	Chauhan Ajaykumar B&Priyal A
678 231 33 00	1.00	SFD	H	1.00	1.00	\$0.00	\$0.00	Narayana Prasad C&Ravikumar Kavya B
678 231 34 00	1.00	SFD	H	1.00	1.00	\$0.00	\$0.00	Beeghley Darin M&Sandra K
678 231 35 00	1.00	SFD	H	1.00	1.00	\$0.00	\$0.00	Baker Jedediah S&Perez Maria J Z
678 231 36 00	1.00	SFD	H	1.00	1.00	\$0.00	\$0.00	Spic Del Sur Llc
678 231 37 00	1.00	SFD	H	1.00	1.00	\$0.00	\$0.00	Spic Del Sur Llc
678 231 38 00	0.08	STR	H	0.00	0.00	\$0.00	\$0.00	Black Mountain Ranch L L C
678 231 39 00	0.36	OSP	H	0.00	0.00	\$0.00	\$0.00	Black Mountain Ranch L L C
678 231 40 00	0.01	UND	H	0.00	0.00	\$0.00	\$0.00	Black Mountain Ranch L L C
678 232 01 00	1.00	SFD	H	1.00	1.00	\$0.00	\$0.00	Spic Del Sur Llc
678 232 02 00	1.00	SFD	H	1.00	1.00	\$0.00	\$0.00	Spic Del Sur Llc
678 232 03 00	1.00	SFD	H	1.00	1.00	\$0.00	\$0.00	Spic Del Sur Llc
678 232 04 00	1.00	SFD	H	1.00	1.00	\$0.00	\$0.00	Spic Del Sur Llc
678 232 05 00	1.00	SFD	H	1.00	1.00	\$0.00	\$0.00	Gilson Jerome&Winkin Laura
678 232 06 00	1.00	SFD	H	1.00	1.00	\$0.00	\$0.00	Kwon Yong&Jeanie Jiahn
678 232 07 00	1.00	SFD	H	1.00	1.00	\$0.00	\$0.00	Spic Del Sur Llc
678 232 08 00	1.00	SFD	H	1.00	1.00	\$0.00	\$0.00	Wu Xiaotie&Lu Jie
678 232 09 00	1.00	SFD	H	1.00	1.00	\$0.00	\$0.00	Le Co K&My P
678 232 10 00	1.00	SFD	H	1.00	1.00	\$0.00	\$0.00	Zuo Chengjie&Chen Mengke
678 232 11 00	1.00	SFD	H	1.00	1.00	\$0.00	\$0.00	Weerakkody Sadith L&Wickramarathna Thamali D
678 232 12 00	1.00	SFD	H	1.00	1.00	\$0.00	\$0.00	Zhao Jian&Zhang Yanting
678 232 13 00	1.00	SFD	H	1.00	1.00	\$0.00	\$0.00	Cavallo Keith J&Erin M
678 232 14 00	1.00	SFD	H	1.00	1.00	\$0.00	\$0.00	Spic Del Sur Llc
678 232 15 00	1.00	SFD	H	1.00	1.00	\$0.00	\$0.00	Spic Del Sur Llc
678 232 16 00	1.00	SFD	H	1.00	1.00	\$0.00	\$0.00	Spic Del Sur Llc
678 232 17 00	1.00	SFD	H	1.00	1.00	\$0.00	\$0.00	Spic Del Sur Llc
678 232 18 00	1.00	SFD	H	1.00	1.00	\$0.00	\$0.00	Spic Del Sur Llc
678 232 19 00	1.00	SFD	H	1.00	1.00	\$0.00	\$0.00	Spic Del Sur Llc

EXHIBIT C - Assessment Roll (Fiscal Year 2017)
Black Mountain Ranch North Maintenance Assessment District

Parcel Number	Acres/ Units ⁽¹⁾	Land Use Code ⁽²⁾	Zone	Land Use Factor ⁽²⁾	Total EBUs	Unit Cost (\$/Ebu)	FY 2017 ⁽³⁾ Assessment	Owner Name
678 232 20 00	1.00	SFD	H	1.00	1.00	\$0.00	\$0.00	Spic Del Sur Llc
678 232 21 00	1.00	SFD	H	1.00	1.00	\$0.00	\$0.00	Spic Del Sur Llc
678 232 22 00	1.00	SFD	H	1.00	1.00	\$0.00	\$0.00	Spic Del Sur Llc
678 232 23 00	1.00	SFD	H	1.00	1.00	\$0.00	\$0.00	Spic Del Sur Llc
678 232 24 00	1.00	SFD	H	1.00	1.00	\$0.00	\$0.00	Spic Del Sur Llc
678 232 25 00	1.00	SFD	H	1.00	1.00	\$0.00	\$0.00	Bercovitch-Ishimoto Family Trust 10-15-15
678 232 26 00	1.00	SFD	H	1.00	1.00	\$0.00	\$0.00	Citerony Glenn A&Jacqueline F
678 232 27 00	1.00	SFD	H	1.00	1.00	\$0.00	\$0.00	Weis Jonathan&Jena
678 232 28 00	1.00	SFD	H	1.00	1.00	\$0.00	\$0.00	Beldin Lia Trust 10-15-13
678 232 29 00	1.00	SFD	H	1.00	1.00	\$0.00	\$0.00	Saini Ashwani
678 232 30 00	1.00	SFD	H	1.00	1.00	\$0.00	\$0.00	Spic Del Sur Llc
678 232 31 00	1.00	SFD	H	1.00	1.00	\$0.00	\$0.00	Gaurav Anand&Manya Milton
678 232 32 00	1.00	SFD	H	1.00	1.00	\$0.00	\$0.00	Cutler Michael L&Kuzmenko Iulilia
678 232 33 00	1.00	SFD	H	1.00	1.00	\$0.00	\$0.00	Hayes Michael F&Kelly N
678 232 34 00	1.00	SFD	H	1.00	1.00	\$0.00	\$0.00	Lai Tina L
678 232 35 00	1.00	SFD	H	1.00	1.00	\$0.00	\$0.00	Soong John
678 232 36 00	1.00	SFD	H	1.00	1.00	\$0.00	\$0.00	Jeong Hyo Myung&Kim Hee Soo
678 232 37 00	1.00	SFD	H	1.00	1.00	\$0.00	\$0.00	Miller Joel B&Madison E
678 232 38 00	1.00	SFD	H	1.00	1.00	\$0.00	\$0.00	Zhao Chunmei&Sun Huaiyu
678 232 39 00	1.00	SFD	H	1.00	1.00	\$0.00	\$0.00	Brandon Clayton&Ly Lien
678 232 40 00	1.00	SFD	H	1.00	1.00	\$0.00	\$0.00	Spic Del Sur Llc
678 232 41 00	1.00	SFD	H	1.00	1.00	\$0.00	\$0.00	Spic Del Sur Llc
678 232 42 00	1.00	SFD	H	1.00	1.00	\$0.00	\$0.00	Sirohi Kapil&Archana
678 232 43 00	1.00	SFD	H	1.00	1.00	\$0.00	\$0.00	Castano Nereimiah J&Joy M
678 232 44 00	1.00	SFD	H	1.00	1.00	\$0.00	\$0.00	Rosen Kevin C
678 232 45 00	1.00	SFD	H	1.00	1.00	\$0.00	\$0.00	Spic Del Sur Llc
678 232 46 00	1.00	SFD	H	1.00	1.00	\$0.00	\$0.00	Spic Del Sur Llc
678 232 47 00	1.00	SFD	H	1.00	1.00	\$0.00	\$0.00	Spic Del Sur Llc
678 232 48 00	1.00	SFD	H	1.00	1.00	\$0.00	\$0.00	Spic Del Sur Llc
678 232 49 00	1.00	SFD	H	1.00	1.00	\$0.00	\$0.00	Spic Del Sur Llc
678 232 50 00	1.00	SFD	H	1.00	1.00	\$0.00	\$0.00	Spic Del Sur Llc
678 232 51 00	1.00	SFD	H	1.00	1.00	\$0.00	\$0.00	Spic Del Sur Llc
678 232 52 00	1.00	SFD	H	1.00	1.00	\$0.00	\$0.00	Spic Del Sur Llc
678 232 53 00	1.00	SFD	H	1.00	1.00	\$0.00	\$0.00	Spic Del Sur Llc
678 232 54 00	1.00	SFD	H	1.00	1.00	\$0.00	\$0.00	Spic Del Sur Llc
678 232 55 00	1.00	SFD	H	1.00	1.00	\$0.00	\$0.00	Spic Del Sur Llc
678 232 56 00	1.00	SFD	H	1.00	1.00	\$0.00	\$0.00	Spic Del Sur Llc
678 232 57 00	1.00	SFD	H	1.00	1.00	\$0.00	\$0.00	Spic Del Sur Llc
678 232 58 00	1.00	SFD	H	1.00	1.00	\$0.00	\$0.00	Spic Del Sur Llc
678 232 59 00	1.00	SFD	H	1.00	1.00	\$0.00	\$0.00	Spic Del Sur Llc
678 232 60 00	1.00	SFD	H	1.00	1.00	\$0.00	\$0.00	Spic Del Sur Llc
678 232 61 00	1.00	SFD	H	1.00	1.00	\$0.00	\$0.00	Spic Del Sur Llc
678 232 62 00	1.00	SFD	H	1.00	1.00	\$0.00	\$0.00	Spic Del Sur Llc
678 232 63 00	1.00	SFD	H	1.00	1.00	\$0.00	\$0.00	Spic Del Sur Llc
678 232 64 00	1.00	SFD	H	1.00	1.00	\$0.00	\$0.00	Spic Del Sur Llc
678 232 65 00	1.00	SFD	H	1.00	1.00	\$0.00	\$0.00	Adamczyk Thomas H
678 232 66 00	1.00	SFD	H	1.00	1.00	\$0.00	\$0.00	Caballes Joehn S&Therese C
678 232 67 00	1.00	SFD	H	1.00	1.00	\$0.00	\$0.00	Raman Arun&Krishnamurthy Chitra
678 232 68 00	1.00	SFD	H	1.00	1.00	\$0.00	\$0.00	Hardin Justin&Robles Paola
678 232 69 00	1.00	SFD	H	1.00	1.00	\$0.00	\$0.00	Green Marjan
678 232 70 00	1.00	SFD	H	1.00	1.00	\$0.00	\$0.00	Hughes Christopher J&Barnes Mary R
678 232 71 00	1.00	SFD	H	1.00	1.00	\$0.00	\$0.00	Shah Kunal R&Shruti
678 232 72 00	1.00	SFD	H	1.00	1.00	\$0.00	\$0.00	Prakash Ramana B
678 232 73 00	1.00	SFD	H	1.00	1.00	\$0.00	\$0.00	Spic Del Sur Llc
678 232 74 00	1.00	SFD	H	1.00	1.00	\$0.00	\$0.00	Spic Del Sur Llc
678 232 75 00	1.00	SFD	H	1.00	1.00	\$0.00	\$0.00	Spic Del Sur Llc
678 232 76 00	1.00	SFD	H	1.00	1.00	\$0.00	\$0.00	Spic Del Sur Llc
678 232 77 00	1.00	SFD	H	1.00	1.00	\$0.00	\$0.00	Spic Del Sur Llc
678 232 78 00	1.00	SFD	H	1.00	1.00	\$0.00	\$0.00	Spic Del Sur Llc

EXHIBIT C - Assessment Roll (Fiscal Year 2017)
Black Mountain Ranch North Maintenance Assessment District

Parcel Number	Acres/ Units ⁽¹⁾	Land Use Code ⁽²⁾	Zone	Land Use Factor ⁽²⁾	Total EBUs	Unit Cost (\$/EUBU)	FY 2017 ⁽³⁾ Assessment	Owner Name
678 232 79 00	1.00	SFD	H	1.00	1.00	\$0.00	\$0.00	Spic Del Sur Llc
678 232 80 00	1.00	SFD	H	1.00	1.00	\$0.00	\$0.00	Spic Del Sur Llc
678 232 81 00	1.00	SFD	H	1.00	1.00	\$0.00	\$0.00	Ferreira J K Family Trust 08-07-12
678 232 82 00	1.59	PKU	H	0.50	0.80	\$0.00	\$0.00	Black Mountain Ranch L L C
678 232 83 00	0.31	OSP	H	0.00	0.00	\$0.00	\$0.00	Black Mountain Ranch L L C
678 233 01 00	1.00	SFD	H	1.00	1.00	\$0.00	\$0.00	Spic Del Sur Llc
678 233 02 00	1.00	SFD	H	1.00	1.00	\$0.00	\$0.00	Spic Del Sur Llc
678 233 03 00	1.00	SFD	H	1.00	1.00	\$0.00	\$0.00	Shah Sandeep J&Patel Swati K
678 233 04 00	1.00	SFD	H	1.00	1.00	\$0.00	\$0.00	Chodorow Devin S&Jessica G
678 233 05 00	1.00	SFD	H	1.00	1.00	\$0.00	\$0.00	Scheinblum Family Trust 08-19-14
678 233 06 00	1.00	SFD	H	1.00	1.00	\$0.00	\$0.00	Meierhofer Stefan&Kim
678 233 07 00	1.00	SFD	H	1.00	1.00	\$0.00	\$0.00	Spic Del Sur Llc
678 233 08 00	1.00	SFD	H	1.00	1.00	\$0.00	\$0.00	Parthasarathy Family Trust 11-09-14
678 233 09 00	1.00	SFD	H	1.00	1.00	\$0.00	\$0.00	Spic Del Sur Llc
678 233 10 00	1.00	SFD	H	1.00	1.00	\$0.00	\$0.00	Weinstock Nick&Iris Trust 11-20-14
678 233 11 00	1.00	SFD	H	1.00	1.00	\$0.00	\$0.00	Guzenski Andrew A&Leah C
678 233 12 00	1.00	SFD	H	1.00	1.00	\$0.00	\$0.00	Watson Thomas R&Vassey Nicole
678 233 13 00	1.00	SFD	H	1.00	1.00	\$0.00	\$0.00	Bi Xiaoyan
678 233 14 00	1.00	SFD	H	1.00	1.00	\$0.00	\$0.00	Weisfeld Michael&Amanda
678 233 15 00	1.00	SFD	H	1.00	1.00	\$0.00	\$0.00	Kou Bohua
678 233 16 00	1.00	SFD	H	1.00	1.00	\$0.00	\$0.00	Whittaker Jason E&Romero-Whittaker Jill N
678 233 17 00	1.00	SFD	H	1.00	1.00	\$0.00	\$0.00	Markus Mikko&Bryman Johanna
678 233 18 00	1.00	SFD	H	1.00	1.00	\$0.00	\$0.00	Kwan Derek D
678 233 19 00	1.00	SFD	H	1.00	1.00	\$0.00	\$0.00	Pragasam Dharmaraj&Dharmaraj Mary P
678 233 20 00	1.00	SFD	H	1.00	1.00	\$0.00	\$0.00	George Rodney Trust 07-06-11
678 233 21 00	1.00	SFD	H	1.00	1.00	\$0.00	\$0.00	Wu Kun&Zheng Yi Jenny
678 233 22 00	1.00	SFD	H	1.00	1.00	\$0.00	\$0.00	Sapkal Dnyandeo T&Anjali D
678 233 23 00	1.00	SFD	H	1.00	1.00	\$0.00	\$0.00	Desai Bhavan Y&Agn U
678 233 24 00	1.00	SFD	H	1.00	1.00	\$0.00	\$0.00	Cutter Ryan J&June Y
678 233 25 00	1.00	SFD	H	1.00	1.00	\$0.00	\$0.00	Whitwell Thomas L
678 233 26 00	1.00	SFD	H	1.00	1.00	\$0.00	\$0.00	Thach Robert&Tran Nancy
678 233 27 00	1.00	SFD	H	1.00	1.00	\$0.00	\$0.00	Schaefer Family Revocable Living Trust 02-25-08
678 233 28 00	1.00	SFD	H	1.00	1.00	\$0.00	\$0.00	Church David P&Carla S
678 233 29 00	1.00	SFD	H	1.00	1.00	\$0.00	\$0.00	Peterson Bruce E&Melanie A
678 233 30 00	1.00	SFD	H	1.00	1.00	\$0.00	\$0.00	Ngo Albert M&Jennifer C
678 233 31 00	1.00	SFD	H	1.00	1.00	\$0.00	\$0.00	Bajwa Fizzah&Ozair
678 233 32 00	1.00	SFD	H	1.00	1.00	\$0.00	\$0.00	Kaufman Family Trust 07-12-11
678 233 33 00	1.00	SFD	H	1.00	1.00	\$0.00	\$0.00	Spic Del Sur Llc
678 233 34 00	1.00	SFD	H	1.00	1.00	\$0.00	\$0.00	Spic Del Sur Llc
678 233 35 00	1.00	SFD	H	1.00	1.00	\$0.00	\$0.00	Spic Del Sur Llc
678 233 36 00	1.00	SFD	H	1.00	1.00	\$0.00	\$0.00	Spic Del Sur Llc
678 233 37 00	1.00	SFD	H	1.00	1.00	\$0.00	\$0.00	Hicks Elliot
678 233 38 00	1.00	SFD	H	1.00	1.00	\$0.00	\$0.00	Piracha Kashan&Maryam K
678 233 39 00	1.00	SFD	H	1.00	1.00	\$0.00	\$0.00	Walker Family Trust 09-02-14
678 233 40 00	1.00	SFD	H	1.00	1.00	\$0.00	\$0.00	Li Lyon&Ren Minrong
678 233 41 00	1.00	SFD	H	1.00	1.00	\$0.00	\$0.00	Hasan Syed Z U&Parvez S P S Z U
678 233 42 00	1.00	SFD	H	1.00	1.00	\$0.00	\$0.00	Cheng Ching-Ying&Yang Rue-Er
678 233 43 00	1.00	SFD	H	1.00	1.00	\$0.00	\$0.00	Glazner Matthew T&Courtney
678 233 44 00	1.00	SFD	H	1.00	1.00	\$0.00	\$0.00	Vahia Varin S&Bhatt Kadambi U
678 233 45 00	1.00	SFD	H	1.00	1.00	\$0.00	\$0.00	Lee Daniel S0Nghak&Kim Yanghee
678 233 46 00	1.00	SFD	H	1.00	1.00	\$0.00	\$0.00	Tan Jun&Bao Mingji
678 233 47 00	1.00	SFD	H	1.00	1.00	\$0.00	\$0.00	Zyman Family Trust 10-28-14
678 233 48 00	1.00	SFD	H	1.00	1.00	\$0.00	\$0.00	Saini Kamaljit K
678 233 49 00	1.00	SFD	H	1.00	1.00	\$0.00	\$0.00	Hosmani Jagadeesh&Girwalker Ashwini
678 233 50 00	1.00	SFD	H	1.00	1.00	\$0.00	\$0.00	Lancaster Derek P&Lauren G
678 233 51 00	1.00	SFD	H	1.00	1.00	\$0.00	\$0.00	Kumar Atin&Bhatnagar Meghna
678 233 52 00	1.00	SFD	H	1.00	1.00	\$0.00	\$0.00	Cheah Benjamin
678 233 53 00	1.00	SFD	H	1.00	1.00	\$0.00	\$0.00	Castronovo Arthur J&Loren J
678 233 54 00	1.00	SFD	H	1.00	1.00	\$0.00	\$0.00	Monday Jeffrey R&Tiffany N

EXHIBIT C - Assessment Roll (Fiscal Year 2017)
Black Mountain Ranch North Maintenance Assessment District

Parcel Number	Acres/ Units ⁽¹⁾	Land Use Code ⁽²⁾	Zone	Land Use Factor ⁽²⁾	Total EBUs	Unit Cost (\$/Ebu)	FY 2017 ⁽³⁾ Assessment	Owner Name
678 233 55 00	1.00	SFD	H	1.00	1.00	\$0.00	\$0.00	Cordell Timothy&Lara Revocable Living Trust 02-05-10
678 233 56 00	0.11	OSP	H	0.00	0.00	\$0.00	\$0.00	Black Mountain Ranch L L C
678 234 01 00	1.00	SFD	H	1.00	1.00	\$0.00	\$0.00	Spic Del Sur Llc
678 234 02 00	1.00	SFD	H	1.00	1.00	\$0.00	\$0.00	Spic Del Sur Llc
678 234 03 00	1.00	SFD	H	1.00	1.00	\$0.00	\$0.00	Spic Del Sur Llc
678 234 04 00	1.00	SFD	H	1.00	1.00	\$0.00	\$0.00	Plishner Family Trust 11-13-15
678 234 05 00	1.00	SFD	H	1.00	1.00	\$0.00	\$0.00	Hayek Brian J&Ashley A
678 234 06 00	1.00	SFD	H	1.00	1.00	\$0.00	\$0.00	Spic Del Sur Llc
678 234 07 00	1.00	SFD	H	1.00	1.00	\$0.00	\$0.00	Spic Del Sur Llc
678 234 08 00	1.00	SFD	H	1.00	1.00	\$0.00	\$0.00	Arthur Michael P&Dana E G
678 234 09 00	1.00	SFD	H	1.00	1.00	\$0.00	\$0.00	Spic Del Sur Llc
678 234 10 00	1.00	SFD	H	1.00	1.00	\$0.00	\$0.00	Spic Del Sur Llc
678 234 11 00	1.00	SFD	H	1.00	1.00	\$0.00	\$0.00	Hart Kenneth P&Rachel M
678 234 12 00	1.00	SFD	H	1.00	1.00	\$0.00	\$0.00	Heffelfinger Jason L&Stacy A
678 234 13 00	1.00	SFD	H	1.00	1.00	\$0.00	\$0.00	Kaushik Vinod&Gunta Sujana
678 234 14 00	1.00	SFD	H	1.00	1.00	\$0.00	\$0.00	Vaddi Ravichandra R&Malleswari
678 234 15 00	1.00	SFD	H	1.00	1.00	\$0.00	\$0.00	Joshi Bhargav&Prapti
678 234 16 00	1.00	SFD	H	1.00	1.00	\$0.00	\$0.00	Yang Zhifa&Mei Gan
678 234 17 00	1.00	SFD	H	1.00	1.00	\$0.00	\$0.00	Ravula Satheesh B&Suchitra
678 234 18 00	1.00	SFD	H	1.00	1.00	\$0.00	\$0.00	Pang Gregory J&Tran-Pang Jessica A
678 234 19 00	1.00	SFD	H	1.00	1.00	\$0.00	\$0.00	Petzold Daniel A&Zeng Huiwen
678 234 20 00	1.00	SFD	H	1.00	1.00	\$0.00	\$0.00	Jones Nathan&Lindsay
678 234 21 00	1.00	SFD	H	1.00	1.00	\$0.00	\$0.00	Konat Nicholas G&Tara J
678 234 22 00	1.00	SFD	H	1.00	1.00	\$0.00	\$0.00	Le Thuy D&Le-Pham Van
678 234 23 00	1.00	SFD	H	1.00	1.00	\$0.00	\$0.00	Godkin Sam
678 234 24 00	1.00	SFD	H	1.00	1.00	\$0.00	\$0.00	Ellis Bradley C Trust 07-12-84
678 234 25 00	1.00	SFD	H	1.00	1.00	\$0.00	\$0.00	Liang Clark&Gao Xueting
678 234 26 00	1.00	SFD	H	1.00	1.00	\$0.00	\$0.00	Givens Chadwick F&Erika R
678 234 27 00	1.00	SFD	H	1.00	1.00	\$0.00	\$0.00	Pastrano Kirk A&Ellen C
678 234 28 00	1.00	SFD	H	1.00	1.00	\$0.00	\$0.00	Namoca Ceazar&Ferrer Anna
678 234 29 00	1.00	SFD	H	1.00	1.00	\$0.00	\$0.00	Dick C&L Family Trust 06-09-13
678 234 30 00	1.00	SFD	H	1.00	1.00	\$0.00	\$0.00	Lee Diane K
678 234 31 00	1.00	SFD	H	1.00	1.00	\$0.00	\$0.00	Younghouse Mark&Michelle
678 234 32 00	1.00	SFD	H	1.00	1.00	\$0.00	\$0.00	Sozzi Rick&Garrene Michelle
678 234 33 00	1.00	SFD	H	1.00	1.00	\$0.00	\$0.00	Kogan Family Trust 05-16-14
678 234 34 00	1.00	SFD	H	1.00	1.00	\$0.00	\$0.00	Mushet Broc A&Shay B
678 234 35 00	1.00	SFD	H	1.00	1.00	\$0.00	\$0.00	Dhokia Yogesh K&Anila Y
678 234 36 00	1.00	SFD	H	1.00	1.00	\$0.00	\$0.00	Thomas Joe&Nimmi
678 234 37 00	1.32	PKU	H	0.50	0.66	\$0.00	\$0.00	Black Mountain Ranch L L C
678 235 01 00	1.00	SFD	H	1.00	1.00	\$0.00	\$0.00	Spic Del Sur Llc
678 235 02 00	1.00	SFD	H	1.00	1.00	\$0.00	\$0.00	Spic Del Sur Llc
678 235 03 00	1.00	SFD	H	1.00	1.00	\$0.00	\$0.00	Spic Del Sur Llc
678 235 04 00	1.00	SFD	H	1.00	1.00	\$0.00	\$0.00	Spic Del Sur Llc
678 235 05 00	1.00	SFD	H	1.00	1.00	\$0.00	\$0.00	Spic Del Sur Llc
678 235 06 00	1.00	SFD	H	1.00	1.00	\$0.00	\$0.00	Spic Del Sur Llc
678 235 07 00	1.00	SFD	H	1.00	1.00	\$0.00	\$0.00	Spic Del Sur Llc
678 235 08 00	1.00	SFD	H	1.00	1.00	\$0.00	\$0.00	Spic Del Sur Llc
678 235 09 00	1.00	SFD	H	1.00	1.00	\$0.00	\$0.00	Spic Del Sur Llc
678 235 10 00	1.00	SFD	H	1.00	1.00	\$0.00	\$0.00	Spic Del Sur Llc
678 235 11 00	1.00	SFD	H	1.00	1.00	\$0.00	\$0.00	Spic Del Sur Llc
678 235 12 00	1.00	SFD	H	1.00	1.00	\$0.00	\$0.00	Spic Del Sur Llc
678 235 13 00	1.00	SFD	H	1.00	1.00	\$0.00	\$0.00	Spic Del Sur Llc
678 235 14 00	1.00	SFD	H	1.00	1.00	\$0.00	\$0.00	Spic Del Sur Llc
678 235 15 00	1.00	SFD	H	1.00	1.00	\$0.00	\$0.00	Spic Del Sur Llc
678 235 16 00	1.00	SFD	H	1.00	1.00	\$0.00	\$0.00	Spic Del Sur Llc
678 235 17 00	1.00	SFD	H	1.00	1.00	\$0.00	\$0.00	Spic Del Sur Llc
678 235 18 00	1.00	SFD	H	1.00	1.00	\$0.00	\$0.00	Spic Del Sur Llc
678 235 19 00	1.00	SFD	H	1.00	1.00	\$0.00	\$0.00	Spic Del Sur Llc
678 235 20 00	1.00	SFD	H	1.00	1.00	\$0.00	\$0.00	Spic Del Sur Llc

EXHIBIT C - Assessment Roll (Fiscal Year 2017)
Black Mountain Ranch North Maintenance Assessment District

Parcel Number	Acres/ Units ⁽¹⁾	Land Use Code ⁽²⁾	Zone	Land Use Factor ⁽²⁾	Total EBUs	Unit Cost (\$/EUBU)	FY 2017 ⁽³⁾ Assessment	Owner Name
678 235 21 00	1.00	SFD	H	1.00	1.00	\$0.00	\$0.00	Spic Del Sur Llc
678 235 22 00	1.00	SFD	H	1.00	1.00	\$0.00	\$0.00	Spic Del Sur Llc
678 235 23 00	1.00	SFD	H	1.00	1.00	\$0.00	\$0.00	Spic Del Sur Llc
678 235 24 00	1.00	SFD	H	1.00	1.00	\$0.00	\$0.00	Spic Del Sur Llc
678 235 25 00	1.00	SFD	H	1.00	1.00	\$0.00	\$0.00	Spic Del Sur Llc
678 235 26 00	1.00	SFD	H	1.00	1.00	\$0.00	\$0.00	Spic Del Sur Llc
678 235 27 00	1.00	SFD	H	1.00	1.00	\$0.00	\$0.00	Spic Del Sur Llc
678 235 28 00	1.00	SFD	H	1.00	1.00	\$0.00	\$0.00	Spic Del Sur Llc
678 235 29 00	1.00	SFD	H	1.00	1.00	\$0.00	\$0.00	Spic Del Sur Llc
678 235 30 00	1.00	SFD	H	1.00	1.00	\$0.00	\$0.00	Lee Jung&Susan Family Trust 11-28-11
678 235 31 00	1.00	SFD	H	1.00	1.00	\$0.00	\$0.00	Fogerson Robert S Jr Trust 11-04-11
678 235 32 00	1.00	SFD	H	1.00	1.00	\$0.00	\$0.00	Wong Waisan&Liu Aurora Xiaoyao
678 235 33 00	1.00	SFD	H	1.00	1.00	\$0.00	\$0.00	Rubio Jose A&Ana I
678 235 34 00	1.00	SFD	H	1.00	1.00	\$0.00	\$0.00	Spic Del Sur Llc
678 235 35 00	1.00	SFD	H	1.00	1.00	\$0.00	\$0.00	Spic Del Sur Llc
678 235 36 00	1.00	SFD	H	1.00	1.00	\$0.00	\$0.00	Avila Jose H&Kathleen E
678 235 37 00	1.00	SFD	H	1.00	1.00	\$0.00	\$0.00	Spic Del Sur Llc
678 235 38 00	1.00	SFD	H	1.00	1.00	\$0.00	\$0.00	Chun Philip M&Angela J
678 235 39 00	1.00	SFD	H	1.00	1.00	\$0.00	\$0.00	Stanovcak Joseph&Sandra L
678 235 40 00	1.00	SFD	H	1.00	1.00	\$0.00	\$0.00	Spic Del Sur Llc
678 235 41 00	1.00	SFD	H	1.00	1.00	\$0.00	\$0.00	Spic Del Sur Llc
678 235 42 00	1.00	SFD	H	1.00	1.00	\$0.00	\$0.00	Charo Jason&Jacklyn
678 235 43 00	1.00	SFD	H	1.00	1.00	\$0.00	\$0.00	Spic Del Sur Llc
678 235 44 00	1.00	SFD	H	1.00	1.00	\$0.00	\$0.00	Spic Del Sur Llc
678 235 45 00	1.00	SFD	H	1.00	1.00	\$0.00	\$0.00	Boyle Bryan P&Jacquelyne
678 235 46 00	1.00	SFD	H	1.00	1.00	\$0.00	\$0.00	Gavin Tange L 1991 Trust 08-28-91
678 236 01 00	1.00	SFD	H	1.00	1.00	\$0.00	\$0.00	Spic Del Sur Llc
678 236 02 00	1.00	SFD	H	1.00	1.00	\$0.00	\$0.00	Spic Del Sur Llc
678 236 03 00	1.00	SFD	H	1.00	1.00	\$0.00	\$0.00	Spic Del Sur Llc
678 236 04 00	1.00	SFD	H	1.00	1.00	\$0.00	\$0.00	Spic Del Sur Llc
678 236 05 00	1.00	SFD	H	1.00	1.00	\$0.00	\$0.00	Spic Del Sur Llc
678 236 06 00	1.00	SFD	H	1.00	1.00	\$0.00	\$0.00	Spic Del Sur Llc
678 236 07 00	1.00	SFD	H	1.00	1.00	\$0.00	\$0.00	Spic Del Sur Llc
678 236 08 00	1.00	SFD	H	1.00	1.00	\$0.00	\$0.00	Spic Del Sur Llc
678 236 09 00	1.00	SFD	H	1.00	1.00	\$0.00	\$0.00	Spic Del Sur Llc
678 236 10 00	1.00	SFD	H	1.00	1.00	\$0.00	\$0.00	Spic Del Sur Llc
678 236 11 00	1.00	SFD	H	1.00	1.00	\$0.00	\$0.00	Spic Del Sur Llc
678 236 12 00	1.00	SFD	H	1.00	1.00	\$0.00	\$0.00	Spic Del Sur Llc
678 236 13 00	1.00	SFD	H	1.00	1.00	\$0.00	\$0.00	Spic Del Sur Llc
678 236 14 00	1.00	SFD	H	1.00	1.00	\$0.00	\$0.00	Naqib Rami A
678 236 15 00	1.00	SFD	H	1.00	1.00	\$0.00	\$0.00	Yoon Steven&Lee Chak Han
678 236 16 00	1.00	SFD	H	1.00	1.00	\$0.00	\$0.00	Dines Kevin C&Adrienne A
678 236 17 00	1.00	SFD	H	1.00	1.00	\$0.00	\$0.00	Ciccarelli Steven C&Rene E
678 236 18 00	1.00	SFD	H	1.00	1.00	\$0.00	\$0.00	Taeb Family Trust 04-02-03
678 236 19 00	1.00	SFD	H	1.00	1.00	\$0.00	\$0.00	Fontana Jason T&Sarah
678 236 20 00	1.00	SFD	H	1.00	1.00	\$0.00	\$0.00	Spic Del Sur Llc
678 236 21 00	1.00	SFD	H	1.00	1.00	\$0.00	\$0.00	Chandruang William B
678 236 22 00	1.00	SFD	H	1.00	1.00	\$0.00	\$0.00	Gupta Paras&Tayal Isha
678 236 23 00	1.00	SFD	H	1.00	1.00	\$0.00	\$0.00	Cunningham Jerry L&Kimberly L
678 236 24 00	1.00	SFD	H	1.00	1.00	\$0.00	\$0.00	Spic Del Sur Llc
678 236 25 00	0.05	OSP	H	0.00	0.00	\$0.00	\$0.00	Black Mountain Ranch L L C
678 236 26 00	0.07	OSP	H	0.00	0.00	\$0.00	\$0.00	Black Mountain Ranch L L C
678 236 27 00	0.05	OSP	H	0.00	0.00	\$0.00	\$0.00	Black Mountain Ranch L L C
678 236 28 00	0.06	OSP	H	0.00	0.00	\$0.00	\$0.00	Black Mountain Ranch L L C
678 236 29 00	0.05	OSP	H	0.00	0.00	\$0.00	\$0.00	Black Mountain Ranch L L C
678 237 02 00	3.56	OSP	H	0.00	0.00	\$0.00	\$0.00	Black Mountain Ranch L L C
678 237 03 00	3.07	OSP	H	0.00	0.00	\$0.00	\$0.00	Black Mountain Ranch L L C
678 237 04 00	16.19	OSP	H	0.00	0.00	\$0.00	\$0.00	Black Mountain Ranch L L C
678 237 05 00	2.27	OSP	H	0.00	0.00	\$0.00	\$0.00	Black Mountain Ranch L L C

EXHIBIT C - Assessment Roll (Fiscal Year 2017)
Black Mountain Ranch North Maintenance Assessment District

Parcel Number	Acres/ Units ⁽¹⁾	Land Use Code ⁽²⁾	Zone	Land Use Factor ⁽²⁾	Total EBU's	Unit Cost (\$/EBU)	FY 2017 ⁽³⁾ Assessment	Owner Name
678 237 06 00	7.48	OSP	H	0.00	0.00	\$0.00	\$0.00	Black Mountain Ranch L L C
678 237 07 00	0.07	OSP	H	0.00	0.00	\$0.00	\$0.00	Black Mountain Ranch L L C
678 237 08 00	0.01	OSP	H	0.00	0.00	\$0.00	\$0.00	Black Mountain Ranch L L C
678 620 01 00	119.00	MFR	A	0.70	83.30	\$0.00	\$0.00	Santaluz Family Apts L P
678 620 05 00	0.05	OSP	A	0.00	0.00	\$0.00	\$0.00	Santaluz L L C
678 620 06 00	0.08	OSP	A	0.00	0.00	\$0.00	\$0.00	La Vina Maintenance Corporation
678 620 07 00	0.84	OSP	A	0.00	0.00	\$0.00	\$0.00	La Vina Maintenance Corp
678 620 08 00	1.20	STR	A	0.00	0.00	\$0.00	\$0.00	La Vina Maintenance Corp
678 620 09 01	1.00	SFD	A	1.00	1.00	\$0.00	\$0.00	Alam Jahangir&Rasheda A
678 620 09 02	1.00	SFD	A	1.00	1.00	\$0.00	\$0.00	Sivanandam Sathiyamoorthy T&Sathiyamoorthy Latha
678 620 09 03	1.00	SFD	A	1.00	1.00	\$0.00	\$0.00	Umapathy Arunsundar&Subramanian Kavitha
678 620 09 04	1.00	SFD	A	1.00	1.00	\$0.00	\$0.00	Ibarrola Andrew R&Eulalyn S
678 620 09 05	1.00	SFD	A	1.00	1.00	\$0.00	\$0.00	Sherafatmand Sam
678 620 09 06	1.00	SFD	A	1.00	1.00	\$0.00	\$0.00	Remigio Ryan J&Jeaneath S
678 620 09 07	1.00	SFD	A	1.00	1.00	\$0.00	\$0.00	Parikh Kunjalkumar A
678 620 09 08	1.00	SFD	A	1.00	1.00	\$0.00	\$0.00	Lin Susan T S
678 620 09 09	1.00	SFD	A	1.00	1.00	\$0.00	\$0.00	Bhattacharya Arnab&Battacharya Anamika
678 620 10 01	1.00	SFD	A	1.00	1.00	\$0.00	\$0.00	Liang Jie
678 620 10 02	1.00	SFD	A	1.00	1.00	\$0.00	\$0.00	Mohanty Rashmi R&Patnaik Ananya
678 620 10 03	1.00	SFD	A	1.00	1.00	\$0.00	\$0.00	Trupp Carla L Trust 04-04-12
678 620 10 04	1.00	SFD	A	1.00	1.00	\$0.00	\$0.00	Park Sung Sin
678 620 10 05	1.00	SFD	A	1.00	1.00	\$0.00	\$0.00	Krause Robert E&Deanna M
678 620 10 06	1.00	SFD	A	1.00	1.00	\$0.00	\$0.00	Zhang Wentian&Yong
678 620 11 01	1.00	SFD	A	1.00	1.00	\$0.00	\$0.00	Liu Limin&Jianmei
678 620 11 02	1.00	SFD	A	1.00	1.00	\$0.00	\$0.00	Javien Orlando U Jr&Svetlana G
678 620 11 03	1.00	SFD	A	1.00	1.00	\$0.00	\$0.00	Kazemzadeh Medhi M
678 620 11 04	1.00	SFD	A	1.00	1.00	\$0.00	\$0.00	Botello Melissa
678 620 11 05	1.00	SFD	A	1.00	1.00	\$0.00	\$0.00	Shi Jin&Li Peihan
678 620 11 06	1.00	SFD	A	1.00	1.00	\$0.00	\$0.00	Zhou Zhengyu&Zhu Min
678 620 11 07	1.00	SFD	A	1.00	1.00	\$0.00	\$0.00	Sanding Anthony N&Maria R
678 620 11 08	1.00	SFD	A	1.00	1.00	\$0.00	\$0.00	Yadlapalli Vikas&Yella Naga L
678 620 12 01	1.00	SFD	A	1.00	1.00	\$0.00	\$0.00	Kleist Michael J&Connie W
678 620 12 02	1.00	SFD	A	1.00	1.00	\$0.00	\$0.00	Liu Weiliang&Shi Qian
678 620 12 03	1.00	SFD	A	1.00	1.00	\$0.00	\$0.00	Chou Alan
678 620 12 04	1.00	SFD	A	1.00	1.00	\$0.00	\$0.00	Miller Perry A&Ann
678 620 12 05	1.00	SFD	A	1.00	1.00	\$0.00	\$0.00	Lukmani Mustafa&Patanwala Tasneem
678 620 12 06	1.00	SFD	A	1.00	1.00	\$0.00	\$0.00	Liu Jun&Suo Lin
678 620 12 07	1.00	SFD	A	1.00	1.00	\$0.00	\$0.00	Rehmani Hamida Living Trust 09-22-15
678 620 12 08	1.00	SFD	A	1.00	1.00	\$0.00	\$0.00	Huizar Scott&Coley Jill E
678 620 13 01	1.00	SFD	A	1.00	1.00	\$0.00	\$0.00	Wei Longyin&Ke Zhi
678 620 13 02	1.00	SFD	A	1.00	1.00	\$0.00	\$0.00	Afsaneh Amini
678 620 13 03	1.00	SFD	A	1.00	1.00	\$0.00	\$0.00	Huang Po Hao&Ho Chi Hua
678 620 13 04	1.00	SFD	A	1.00	1.00	\$0.00	\$0.00	Raj Saran&Saran Sangeetha
678 620 13 05	1.00	SFD	A	1.00	1.00	\$0.00	\$0.00	Muthukumar Ramachandran
678 620 13 06	1.00	SFD	A	1.00	1.00	\$0.00	\$0.00	Juneja Anupam&Kalra Sonal
678 620 14 01	1.00	SFD	A	1.00	1.00	\$0.00	\$0.00	Pattanayak Uttam&Shrabonti
678 620 14 02	1.00	SFD	A	1.00	1.00	\$0.00	\$0.00	Deanda Franco H&Jana
678 620 14 03	1.00	SFD	A	1.00	1.00	\$0.00	\$0.00	Latour Dan&Debra
678 620 14 04	1.00	SFD	A	1.00	1.00	\$0.00	\$0.00	Smith Adam P
678 620 14 05	1.00	SFD	A	1.00	1.00	\$0.00	\$0.00	Pacheco Jose R&Kawar Dina
678 620 14 06	1.00	SFD	A	1.00	1.00	\$0.00	\$0.00	Lau Allen&Hu Ming
678 620 14 07	1.00	SFD	A	1.00	1.00	\$0.00	\$0.00	Patel Family Trust 08-30-06
678 620 14 08	1.00	SFD	A	1.00	1.00	\$0.00	\$0.00	Venkataraman Anand&Rajagopalan Lakshmi
678 620 14 09	1.00	SFD	A	1.00	1.00	\$0.00	\$0.00	Rehberg Eric&Lisa
678 681 13 00	1.00	SFD	G	1.00	1.00	\$0.00	\$0.00	Faulkner Family Trust 11-02-15
678 681 14 00	1.00	SFD	G	1.00	1.00	\$0.00	\$0.00	Olsen Jonathan A&Deanna M
678 681 15 00	1.00	SFD	G	1.00	1.00	\$0.00	\$0.00	Lafontaine Devin&Bernard Stephanie
678 681 16 00	1.00	SFD	G	1.00	1.00	\$0.00	\$0.00	Busse Brian C&Wong Christeanna
678 681 17 00	1.00	SFD	G	1.00	1.00	\$0.00	\$0.00	Vajda Family Trust 07-01-91

EXHIBIT C - Assessment Roll (Fiscal Year 2017)
Black Mountain Ranch North Maintenance Assessment District

Parcel Number	Acres/ Units ⁽¹⁾	Land Use Code ⁽²⁾	Zone	Land Use Factor ⁽²⁾	Total EBUs	Unit Cost (\$/EUBU)	FY 2017 ⁽³⁾ Assessment	Owner Name
678 681 18 00	0.05	OSP	G	0.00	0.00	\$0.00	\$0.00	Del Sur Community Assn
678 681 19 00	1.00	SFD	G	1.00	1.00	\$0.00	\$0.00	Spic Del Sur L L C
678 681 20 00	1.00	SFD	G	1.00	1.00	\$0.00	\$0.00	Azimi Said R Revocable Trust 07-08-15
678 681 21 00	1.00	SFD	G	1.00	1.00	\$0.00	\$0.00	Gore Stephen R&Victoria R
678 681 22 00	1.00	SFD	G	1.00	1.00	\$0.00	\$0.00	R M A Capital Holdings Trust 07-15-15
678 681 23 00	1.00	SFD	G	1.00	1.00	\$0.00	\$0.00	Noona Ram P&Padmaja
678 681 24 00	1.00	SFD	G	1.00	1.00	\$0.00	\$0.00	Tran Michael D&Ta Mini
678 681 25 00	1.00	SFD	G	1.00	1.00	\$0.00	\$0.00	Matevossian Vartan M&Kultan Kanokwan
678 681 26 00	1.00	SFD	G	1.00	1.00	\$0.00	\$0.00	Slater Michael S
678 681 27 00	1.00	SFD	G	1.00	1.00	\$0.00	\$0.00	Franco Marietta Trust 01-10-15
678 681 28 00	1.00	SFD	G	1.00	1.00	\$0.00	\$0.00	Cabanayan Generoso S Ili&Gonzales Karen C
678 681 29 00	1.00	SFD	G	1.00	1.00	\$0.00	\$0.00	Baek Chang-Ho&Soo-Mi Lee
678 681 30 00	1.00	SFD	G	1.00	1.00	\$0.00	\$0.00	Aghassi Sarah
678 681 31 00	1.00	SFD	G	1.00	1.00	\$0.00	\$0.00	Cooke Terence G&Tiffany M
678 681 32 00	1.00	SFD	G	1.00	1.00	\$0.00	\$0.00	Gupta Rajesh K&Bansal Shalini
678 681 33 00	1.00	SFD	G	1.00	1.00	\$0.00	\$0.00	Bamford Terri
678 681 34 00	1.00	SFD	G	1.00	1.00	\$0.00	\$0.00	Viveiros David A&Katherine A
678 681 35 00	1.00	SFD	G	1.00	1.00	\$0.00	\$0.00	Tremblay Kevin P&Michelle S
678 681 36 00	1.00	SFD	G	1.00	1.00	\$0.00	\$0.00	Meeler Joseph L Jr&Lauren C
678 681 37 00	1.00	SFD	G	1.00	1.00	\$0.00	\$0.00	Robleto Jose A
678 681 38 00	1.00	SFD	G	1.00	1.00	\$0.00	\$0.00	Venkatesh Shreyas S&Aggarwal Richa
678 681 39 00	1.00	SFD	G	1.00	1.00	\$0.00	\$0.00	Bach Minh&Nguyen Cheryl
678 681 40 00	1.00	SFD	G	1.00	1.00	\$0.00	\$0.00	French Roy D Family Trust 04-07-86
678 681 41 00	1.00	SFD	G	1.00	1.00	\$0.00	\$0.00	Stavrou Dennis&Cortney
678 681 42 00	1.00	SFD	G	1.00	1.00	\$0.00	\$0.00	Quanstrom Eric&Michele
678 681 43 00	1.00	SFD	G	1.00	1.00	\$0.00	\$0.00	Ross Family Trust 12-20-06
678 681 44 00	1.00	SFD	G	1.00	1.00	\$0.00	\$0.00	Schuerger Jonathan&Lindsey
678 681 45 00	1.00	SFD	G	1.00	1.00	\$0.00	\$0.00	Landa Adam&Bova Gina
678 681 46 00	1.00	SFD	G	1.00	1.00	\$0.00	\$0.00	Krishnan Prakash
678 681 47 00	1.00	SFD	G	1.00	1.00	\$0.00	\$0.00	Tam Shiu Yeung&Shirley
678 681 48 00	1.00	SFD	G	1.00	1.00	\$0.00	\$0.00	Singh Ramesh Kumar&Priya
678 681 49 00	1.00	SFD	G	1.00	1.00	\$0.00	\$0.00	Duell Todd
678 681 50 00	1.00	SFD	G	1.00	1.00	\$0.00	\$0.00	Kang Eunjin A
678 681 51 00	1.00	SFD	G	1.00	1.00	\$0.00	\$0.00	Landau Aaron
678 681 52 00	1.00	SFD	G	1.00	1.00	\$0.00	\$0.00	Rahm Amanda M
678 681 53 00	1.00	SFD	G	1.00	1.00	\$0.00	\$0.00	Raman Shrikant&Surabhi
678 681 54 00	1.00	SFD	G	1.00	1.00	\$0.00	\$0.00	Olson Susan E
678 681 55 00	1.00	SFD	G	1.00	1.00	\$0.00	\$0.00	Arredondo David C&Inzunza Rocio D J U
678 681 56 00	1.00	SFD	G	1.00	1.00	\$0.00	\$0.00	Garza William A
678 681 57 00	1.00	SFD	G	1.00	1.00	\$0.00	\$0.00	Shah Aditya&Reema
678 681 58 00	1.00	SFD	G	1.00	1.00	\$0.00	\$0.00	Switzer Patrick G&Mitchell Ashley L
678 681 59 00	1.00	SFD	G	1.00	1.00	\$0.00	\$0.00	Zgliniec Thomas A&Pinkel Laura D
678 681 60 00	1.00	SFD	G	1.00	1.00	\$0.00	\$0.00	Chah Dong Jin&Yen Patricia T
678 681 61 00	1.17	OSP	G	0.00	0.00	\$0.00	\$0.00	Black Mountain Ranch L L C
678 681 62 00	0.03	OSP	G	0.00	0.00	\$0.00	\$0.00	Black Mountain Ranch L L C
678 681 64 01	1.00	CND	G	0.70	0.70	\$0.00	\$0.00	Kosuri Chiranjeevi
678 681 64 02	1.00	CND	G	0.70	0.70	\$0.00	\$0.00	Wanner Philip D&Jennifer K
678 681 64 03	1.00	CND	G	0.70	0.70	\$0.00	\$0.00	Jayaraman Babu&Reddy Kavitha N
678 681 64 04	1.00	CND	G	0.70	0.70	\$0.00	\$0.00	Sivakumar Ramkumar&Chandrasekar Vaani
678 681 64 05	1.00	CND	G	0.70	0.70	\$0.00	\$0.00	Singavarapu Kalyan&Yamani Bhavani
678 681 64 06	1.00	CND	G	0.70	0.70	\$0.00	\$0.00	Sivasubramaniam Shrihari P&Ravindran Sowpemika
678 681 65 01	1.00	CND	G	0.70	0.70	\$0.00	\$0.00	Jessie Darryl S&Julie D
678 681 65 02	1.00	CND	G	0.70	0.70	\$0.00	\$0.00	Lopez David C
678 681 65 03	1.00	CND	G	0.70	0.70	\$0.00	\$0.00	Kneussl James K Ili&Marybeth H
678 681 65 04	1.00	CND	G	0.70	0.70	\$0.00	\$0.00	Charman Gail I 2014 Trust 05-29-14
678 681 65 05	1.00	CND	G	0.70	0.70	\$0.00	\$0.00	Johnson Anthony Patrick&Shohreh
678 681 65 06	1.00	CND	G	0.70	0.70	\$0.00	\$0.00	Kashani Kianoush B&Raissian Yassaman
678 681 66 01	1.00	CND	G	0.70	0.70	\$0.00	\$0.00	Zahn Derek J&Carol M
678 681 66 02	1.00	CND	G	0.70	0.70	\$0.00	\$0.00	Nguyen Christine A

EXHIBIT C - Assessment Roll (Fiscal Year 2017)
Black Mountain Ranch North Maintenance Assessment District

Parcel Number	Acres/ Units ⁽¹⁾	Land Use Code ⁽²⁾	Zone	Land Use Factor ⁽²⁾	Total EBUs	Unit Cost (\$/EUBU)	FY 2017 ⁽³⁾ Assessment	Owner Name
678 681 66 03	1.00	CND	G	0.70	0.70	\$0.00	\$0.00	Federhart Jay
678 681 66 04	1.00	CND	G	0.70	0.70	\$0.00	\$0.00	Salzman Phillip&Wu Chia Chien
678 681 66 05	1.00	CND	G	0.70	0.70	\$0.00	\$0.00	Osborn Taylor C&Keating Breann M
678 681 66 06	1.00	CND	G	0.70	0.70	\$0.00	\$0.00	Lythgoe Todd&Angie
678 681 67 01	1.00	CND	G	0.70	0.70	\$0.00	\$0.00	Chinnaiah Prabhu&Gangaiah Archana
678 681 67 02	1.00	CND	G	0.70	0.70	\$0.00	\$0.00	Palanca Michael N&Carolyn D
678 681 67 03	1.00	CND	G	0.70	0.70	\$0.00	\$0.00	Vann Carol
678 681 67 04	1.00	CND	G	0.70	0.70	\$0.00	\$0.00	Mojonnier Scott
678 681 67 05	1.00	CND	G	0.70	0.70	\$0.00	\$0.00	Lai Shun-Wei&Ku Chung-Min
678 681 68 01	1.00	CND	G	0.70	0.70	\$0.00	\$0.00	Tan Nathan&He Beijia
678 681 68 02	1.00	CND	G	0.70	0.70	\$0.00	\$0.00	Zhou Revocable Living Trust 03-06-14
678 681 68 03	1.00	CND	G	0.70	0.70	\$0.00	\$0.00	Ong Brendan&Wendy
678 681 68 04	1.00	CND	G	0.70	0.70	\$0.00	\$0.00	Mun John&Angela
678 681 69 01	1.00	CND	G	0.70	0.70	\$0.00	\$0.00	Reitze Stephen E&Michelle L
678 681 69 02	1.00	CND	G	0.70	0.70	\$0.00	\$0.00	Zhang Shi C&Ding Xiao Mei
678 681 69 03	1.00	CND	G	0.70	0.70	\$0.00	\$0.00	Nagavarapu Satish&Madhuri
678 681 69 04	1.00	CND	G	0.70	0.70	\$0.00	\$0.00	Ghouse Syed S&Abiddin Noorjahan B Z
678 681 69 05	1.00	CND	G	0.70	0.70	\$0.00	\$0.00	Caravelli Kelly A
678 681 69 06	1.00	CND	G	0.70	0.70	\$0.00	\$0.00	Rane Ashutosh A
678 681 70 00	12.00	CND	G	0.70	8.40	\$0.00	\$0.00	Spic Del Sur L L C
678 682 02 00	1.00	SFD	G	1.00	1.00	\$0.00	\$0.00	Roy Roland C&Wendy F
678 682 03 00	1.00	SFD	G	1.00	1.00	\$0.00	\$0.00	Chang Sungho&Ahn Suna
678 682 04 00	1.00	SFD	G	1.00	1.00	\$0.00	\$0.00	Seeram Prasannakumar&Manjankarni Priya R
678 682 05 00	1.00	SFD	G	1.00	1.00	\$0.00	\$0.00	Lin Jade&Yeh Connie
678 682 06 00	1.00	SFD	G	1.00	1.00	\$0.00	\$0.00	Pulimamidi Krishna&Boorgula Smitha
678 682 07 00	1.00	SFD	G	1.00	1.00	\$0.00	\$0.00	Duan Chengjun&Huang Li
678 682 08 00	1.00	SFD	G	1.00	1.00	\$0.00	\$0.00	Wang Hsiang-Chen Living Trust 08-31-15
678 682 09 00	1.00	SFD	G	1.00	1.00	\$0.00	\$0.00	Koo Vivian
678 682 10 00	1.00	SFD	G	1.00	1.00	\$0.00	\$0.00	Weisman Michael Living Trust 10-09-14
678 682 11 00	1.00	SFD	G	1.00	1.00	\$0.00	\$0.00	Khanani Abdulsamad&Sarah
678 682 12 00	1.00	SFD	G	1.00	1.00	\$0.00	\$0.00	Vaka Sudhir K&Tata Ramya
678 682 13 00	1.00	SFD	G	1.00	1.00	\$0.00	\$0.00	Sinha Ranjan&Verma Rinku
678 682 14 00	1.00	SFD	G	1.00	1.00	\$0.00	\$0.00	Distefano Frank V&Eva P B
678 682 15 00	1.00	SFD	G	1.00	1.00	\$0.00	\$0.00	Grenowitz Alexander W&Shayna R
678 682 16 00	1.00	SFD	G	1.00	1.00	\$0.00	\$0.00	Conroy Family Trust 04-30-12
678 682 17 00	1.00	SFD	G	1.00	1.00	\$0.00	\$0.00	Wilson Jeffrey T&Jeanne T S
678 682 18 00	1.00	SFD	G	1.00	1.00	\$0.00	\$0.00	Zhou Heyue&Yang Zhirui
678 682 19 00	1.00	SFD	G	1.00	1.00	\$0.00	\$0.00	Quach Kinh T&Ha Kim-Hoa T
678 682 20 00	1.00	SFD	G	1.00	1.00	\$0.00	\$0.00	Zimble Gary&Om Khemma
678 682 21 00	1.00	SFD	G	1.00	1.00	\$0.00	\$0.00	Patel Baadal H&Rachana B
678 682 22 00	1.00	SFD	G	1.00	1.00	\$0.00	\$0.00	Piersons Jeffrey T&Sarah
678 682 23 00	1.00	SFD	G	1.00	1.00	\$0.00	\$0.00	Do Chris&Lu Min
678 682 24 00	1.00	SFD	G	1.00	1.00	\$0.00	\$0.00	Lee Seokjin&Park Sun Young
678 682 25 00	1.00	SFD	G	1.00	1.00	\$0.00	\$0.00	Che Nuo
678 682 26 00	1.00	SFD	G	1.00	1.00	\$0.00	\$0.00	Feng Tao
678 682 27 00	1.00	SFD	G	1.00	1.00	\$0.00	\$0.00	Paka Suresh&Gnaneshwar Vijaya V A
678 682 28 00	1.00	SFD	G	1.00	1.00	\$0.00	\$0.00	Jarang Rajesh V&Vidya R
678 682 29 00	1.00	SFD	G	1.00	1.00	\$0.00	\$0.00	Mareboina Naveen C&Udaya A
678 682 30 00	1.00	SFD	G	1.00	1.00	\$0.00	\$0.00	Joseph James D&Tracy C
678 682 31 00	1.00	SFD	G	1.00	1.00	\$0.00	\$0.00	Cho Yoon&Jennifer Family Trust 02-11-15
678 682 32 00	1.00	SFD	G	1.00	1.00	\$0.00	\$0.00	Cho Jinhyun
678 682 33 00	1.00	SFD	G	1.00	1.00	\$0.00	\$0.00	Kollus John&Melinda K
678 682 34 00	1.00	SFD	G	1.00	1.00	\$0.00	\$0.00	Huang Wei&Tao Fei
678 682 35 00	1.00	SFD	G	1.00	1.00	\$0.00	\$0.00	Yue Herbert&Dao Mimi
678 682 36 00	1.00	SFD	G	1.00	1.00	\$0.00	\$0.00	Duranceau Jason&Carrie
678 682 37 00	1.00	SFD	G	1.00	1.00	\$0.00	\$0.00	Billimoria Paul P&Christina P Family Trust 10-31-07
678 682 38 00	1.00	SFD	G	1.00	1.00	\$0.00	\$0.00	Wuchner Mark&Kristi Family 2008 Trust 10-11-08
678 682 39 00	1.00	SFD	G	1.00	1.00	\$0.00	\$0.00	Lung Trevor O&Ashlee A
678 682 40 00	1.00	SFD	G	1.00	1.00	\$0.00	\$0.00	Warren David D&Jennifer

EXHIBIT C - Assessment Roll (Fiscal Year 2017)
Black Mountain Ranch North Maintenance Assessment District

Parcel Number	Acres/ Units ⁽¹⁾	Land Use Code ⁽²⁾	Zone	Land Use Factor ⁽²⁾	Total EBUs	Unit Cost (\$/EUBU)	FY 2017 ⁽³⁾ Assessment	Owner Name
678 682 47 00	2.43	OSP	G	0.00	0.00	\$0.00	\$0.00	Del Sur Community Assn
678 682 48 00	4.17	OSP	G	0.00	0.00	\$0.00	\$0.00	Del Sur Community Assn
678 682 49 00	0.03	OSP	G	0.00	0.00	\$0.00	\$0.00	Del Sur Community Association
678 682 50 00	0.03	OSP	G	0.00	0.00	\$0.00	\$0.00	Del Sur Community Assn
678 682 51 00	0.04	OSP	G	0.00	0.00	\$0.00	\$0.00	Del Sur Community Assn
678 682 53 00	0.04	OSP	G	0.00	0.00	\$0.00	\$0.00	Black Mountain Ranch L L C
678 682 54 00	0.04	OSP	G	0.00	0.00	\$0.00	\$0.00	Black Mountain Ranch L L C
678 682 55 00	0.02	OSP	G	0.00	0.00	\$0.00	\$0.00	Black Mountain Ranch L L C
678 682 56 00	0.02	OSP	G	0.00	0.00	\$0.00	\$0.00	Black Mountain Ranch L L C
678 682 57 00	0.19	STR	G	0.00	0.00	\$0.00	\$0.00	Del Sur Community Assn
678 682 58 00	0.14	STR	G	0.00	0.00	\$0.00	\$0.00	Black Mountain Ranch L L C
678 682 59 00	0.06	STR	G	0.00	0.00	\$0.00	\$0.00	Black Mountain Ranch L L C
678 682 60 00	0.05	OSP	G	0.00	0.00	\$0.00	\$0.00	Del Sur Community Assn
678 682 61 00	0.04	OSP	G	0.00	0.00	\$0.00	\$0.00	Del Sur Community Assn
678 682 62 00	0.03	OSP	G	0.00	0.00	\$0.00	\$0.00	Del Sur Community Assn
678 682 63 00	0.06	OSP	G	0.00	0.00	\$0.00	\$0.00	Del Sur Community Assn
678 682 64 00	0.05	STR	G	0.00	0.00	\$0.00	\$0.00	Del Sur Community Assn
678 682 65 00	0.48	STR	G	0.00	0.00	\$0.00	\$0.00	Black Mountain Ranch L L C
678 682 66 00	0.15	STR	G	0.00	0.00	\$0.00	\$0.00	Black Mountain Ranch L L C
678 682 67 00	0.17	STR	G	0.00	0.00	\$0.00	\$0.00	Del Sur Community Assn
678 682 77 00	1.00	SFD	G	1.00	1.00	\$0.00	\$0.00	Patil Neelesh&Shanbhag Reshma
678 682 78 00	1.00	SFD	G	1.00	1.00	\$0.00	\$0.00	Dorf Barron J&Christina R
678 682 82 00	0.39	OSP	G	0.00	0.00	\$0.00	\$0.00	Black Mountain Ranch L L C
678 682 83 00	0.39	OSP	G	0.00	0.00	\$0.00	\$0.00	Black Mountain Ranch L L C
678 682 84 00	0.13	OSP	G	0.00	0.00	\$0.00	\$0.00	Del Sur Community Assn
678 682 86 00	0.11	OSP	G	0.00	0.00	\$0.00	\$0.00	Del Sur Community Assn
678 682 87 00	0.82	PKU	G	0.50	0.41	\$0.00	\$0.00	Del Sur Community Association
678 682 88 00	0.37	OSP	G	0.00	0.00	\$0.00	\$0.00	Black Mountain Ranch L L C
678 682 89 00	1.00	SFD	G	1.00	1.00	\$0.00	\$0.00	Habashi Afshin&Maryam
678 682 90 00	1.00	SFD	G	1.00	1.00	\$0.00	\$0.00	Lampert David&Bridget Trust 12-16-15
678 682 91 00	1.00	SFD	G	1.00	1.00	\$0.00	\$0.00	Li Fang
678 682 92 00	2.09	OSP	G	0.00	0.00	\$0.00	\$0.00	Del Sur Community Association
678 682 93 00	0.01	OSP	G	0.00	0.00	\$0.00	\$0.00	Spic Del Sur L L C
678 682 94 00	0.01	OSP	G	0.00	0.00	\$0.00	\$0.00	Spic Del Sur L L C
678 683 01 00	1.00	SFD	G	1.00	1.00	\$0.00	\$0.00	Neiner Jason E&Chou Patricia
678 683 02 00	1.00	SFD	G	1.00	1.00	\$0.00	\$0.00	Shorb Jason D&Elyce
678 683 03 00	1.00	SFD	G	1.00	1.00	\$0.00	\$0.00	Zheng Dongqiang&Tan Weiwei
678 683 04 00	1.00	SFD	G	1.00	1.00	\$0.00	\$0.00	Youm Chan Hak&Chi Nayoung
678 683 05 00	1.00	SFD	G	1.00	1.00	\$0.00	\$0.00	Sadeghi Pouriya&Ehtiyati Neda
678 683 06 00	1.00	SFD	G	1.00	1.00	\$0.00	\$0.00	Zhang Donghui&Chen Yuqing
678 683 07 00	1.00	SFD	G	1.00	1.00	\$0.00	\$0.00	Chukkala Vishwanath&Parre Shruthi
678 683 08 00	1.00	SFD	G	1.00	1.00	\$0.00	\$0.00	Lee Justin Y&Fung Michelle M
678 683 09 00	1.00	SFD	G	1.00	1.00	\$0.00	\$0.00	Miyan Ravindra&Poonam
678 683 10 00	1.00	SFD	G	1.00	1.00	\$0.00	\$0.00	Anderson Family Trust 09-27-13
678 683 11 00	1.00	SFD	G	1.00	1.00	\$0.00	\$0.00	Jaime Carlo E C
678 683 12 00	1.00	SFD	G	1.00	1.00	\$0.00	\$0.00	Mijares Richard&Rachel
678 683 13 00	1.00	SFD	G	1.00	1.00	\$0.00	\$0.00	Bodepudi Durga S&Lakshmi S
678 683 14 00	1.00	SFD	G	1.00	1.00	\$0.00	\$0.00	Chen Xiaoming&Zang Yan
678 683 15 00	1.00	SFD	G	1.00	1.00	\$0.00	\$0.00	Razavi Seyed A S A&Ataai Pamela P
678 683 16 00	1.00	SFD	G	1.00	1.00	\$0.00	\$0.00	Schoonover Angela
678 683 17 00	1.00	SFD	G	1.00	1.00	\$0.00	\$0.00	Kim Christopher J&Rosa F Cheuk
678 683 18 00	1.00	SFD	G	1.00	1.00	\$0.00	\$0.00	Mine Blake T&Kathryn W
678 683 19 00	1.00	SFD	G	1.00	1.00	\$0.00	\$0.00	Flegal James&Amanda
678 683 20 00	1.00	SFD	G	1.00	1.00	\$0.00	\$0.00	Chin Michael G&Tiffany Maelim Liu
678 683 21 00	1.00	SFD	G	1.00	1.00	\$0.00	\$0.00	Lederer Family Trust 08-29-02
678 683 22 00	1.00	SFD	G	1.00	1.00	\$0.00	\$0.00	Coleman Craig&Rebecca
678 683 23 00	1.00	SFD	G	1.00	1.00	\$0.00	\$0.00	Pansky Kevin&Jackson Vanessa
678 683 24 00	1.00	SFD	G	1.00	1.00	\$0.00	\$0.00	Shlita Sargon
678 683 25 00	1.00	SFD	G	1.00	1.00	\$0.00	\$0.00	Oreshack Family Revocable Trust 08-14-09

EXHIBIT C - Assessment Roll (Fiscal Year 2017)
Black Mountain Ranch North Maintenance Assessment District

Parcel Number	Acres/ Units ⁽¹⁾	Land Use Code ⁽²⁾	Zone	Land Use Factor ⁽²⁾	Total EBUs	Unit Cost (\$/EUBU)	FY 2017 ⁽³⁾ Assessment	Owner Name
678 683 26 00	1.00	SFD	G	1.00	1.00	\$0.00	\$0.00	Tannous Joseph A&Isaac Manaar R
678 683 27 00	1.00	SFD	G	1.00	1.00	\$0.00	\$0.00	Iribarren Miguel&Sonja
678 683 28 00	1.00	SFD	G	1.00	1.00	\$0.00	\$0.00	Brenneis James A&Potenziani Cyrena K
678 683 29 00	1.00	SFD	G	1.00	1.00	\$0.00	\$0.00	Barba Daniel&Jill
678 683 30 00	1.00	SFD	G	1.00	1.00	\$0.00	\$0.00	Hunter Brent&Barbara
678 683 31 00	1.00	SFD	G	1.00	1.00	\$0.00	\$0.00	Sherwood Jennifer
678 683 32 00	1.00	SFD	G	1.00	1.00	\$0.00	\$0.00	Singh Chitranjan K&Sarita
678 683 33 00	1.00	SFD	G	1.00	1.00	\$0.00	\$0.00	Dayana Family Trust 05-28-09
678 683 34 00	1.00	SFD	G	1.00	1.00	\$0.00	\$0.00	Li Zhong Ze&Song Zan Bei
678 683 35 00	1.00	SFD	G	1.00	1.00	\$0.00	\$0.00	Badri Omeed&Lani Trust 03-04-12
678 683 36 00	1.00	SFD	G	1.00	1.00	\$0.00	\$0.00	Hansen Michael D&Michelle F
678 683 37 00	1.00	SFD	G	1.00	1.00	\$0.00	\$0.00	Pham Lan
678 683 38 00	1.00	SFD	G	1.00	1.00	\$0.00	\$0.00	E B Family Trust 01-09-15
678 683 39 00	1.00	SFD	G	1.00	1.00	\$0.00	\$0.00	Soliguen Max V&Aurora M
678 683 40 00	1.00	SFD	G	1.00	1.00	\$0.00	\$0.00	Yu Jianfeng&Tian Yanchun
678 683 41 00	0.79	PKU	G	0.50	0.40	\$0.00	\$0.00	Black Mountain Ranch L L C
678 683 42 00	0.43	OSP	G	0.00	0.00	\$0.00	\$0.00	Del Sur Community Assn
678 683 43 00	0.06	OSP	G	0.00	0.00	\$0.00	\$0.00	Del Sur Community Assn
678 683 44 00	0.03	OSP	G	0.00	0.00	\$0.00	\$0.00	Del Sur Community Assn
678 683 45 00	0.04	OSP	G	0.00	0.00	\$0.00	\$0.00	Del Sur Community Assn
678 683 46 00	0.04	OSP	G	0.00	0.00	\$0.00	\$0.00	Del Sur Community Assn
678 683 47 00	0.03	OSP	G	0.00	0.00	\$0.00	\$0.00	Del Sur Community Assn
678 683 48 00	0.03	OSP	G	0.00	0.00	\$0.00	\$0.00	Del Sur Community Assn
678 683 49 00	0.17	STR	G	0.00	0.00	\$0.00	\$0.00	Del Sur Community Assn
678 683 50 00	0.04	OSP	G	0.00	0.00	\$0.00	\$0.00	Black Mountain Ranch L L C
678 683 51 00	0.06	STR	G	0.00	0.00	\$0.00	\$0.00	Del Sur Community Assn
678 683 52 00	0.19	STR	G	0.00	0.00	\$0.00	\$0.00	Del Sur Community Assn
678 683 53 00	0.19	STR	G	0.00	0.00	\$0.00	\$0.00	Del Sur Community Assn
678 683 54 00	0.23	STR	G	0.00	0.00	\$0.00	\$0.00	Black Mountain Ranch L L C
678 683 55 00	0.05	OSP	G	0.00	0.00	\$0.00	\$0.00	Del Sur Community Assn
678 684 01 00	1.00	SFD	G	1.00	1.00	\$0.00	\$0.00	Davis Phillip L&Taliaferro Rita J
678 684 02 00	1.00	SFD	G	1.00	1.00	\$0.00	\$0.00	Potash Marc S&Kirschen Shayna
678 684 03 00	1.00	SFD	G	1.00	1.00	\$0.00	\$0.00	Bradshaw Michael&Stephanie L
678 684 04 00	1.00	SFD	G	1.00	1.00	\$0.00	\$0.00	Kolker Matthew A&Michelle C
678 684 05 00	1.00	SFD	G	1.00	1.00	\$0.00	\$0.00	Balasubramanian Sairam&Sethuraman Brathibba
678 684 06 00	1.00	SFD	G	1.00	1.00	\$0.00	\$0.00	Voss Andrew&Deborah C
678 684 09 00	1.00	SFD	G	1.00	1.00	\$0.00	\$0.00	Koller Principal Living Trust 07-17-13
678 684 10 00	1.00	SFD	G	1.00	1.00	\$0.00	\$0.00	Shahapurkar Som&Sadanand Sushma
678 684 11 00	1.00	SFD	G	1.00	1.00	\$0.00	\$0.00	Kumar Sanjay&Arunee
678 684 12 00	1.00	SFD	G	1.00	1.00	\$0.00	\$0.00	Chan Marcus W&Heidi K
678 684 13 00	1.00	SFD	G	1.00	1.00	\$0.00	\$0.00	Enyedi Matthew K&Lindsay E
678 684 14 00	1.00	SFD	G	1.00	1.00	\$0.00	\$0.00	Holly Jeremy&Stephanie
678 684 15 00	1.00	SFD	G	1.00	1.00	\$0.00	\$0.00	Witt Steven G&Beth A
678 684 16 00	1.00	SFD	G	1.00	1.00	\$0.00	\$0.00	Lofy Brian&Cheri
678 684 17 00	1.00	SFD	G	1.00	1.00	\$0.00	\$0.00	Meeter Dalen T&Casey M
678 684 18 00	1.00	SFD	G	1.00	1.00	\$0.00	\$0.00	Sundarmurthy Keerthi R&Keerthi Madhumathi
678 684 19 00	1.00	SFD	G	1.00	1.00	\$0.00	\$0.00	Fraikin G&A Family Trust 05-21-15
678 684 20 00	1.00	SFD	G	1.00	1.00	\$0.00	\$0.00	Pervez Rizwan
678 684 21 00	1.00	SFD	G	1.00	1.00	\$0.00	\$0.00	Burke Darren J&Patricia E Family Trust 03-06-15
678 684 27 00	6.32	OSP	G	0.00	0.00	\$0.00	\$0.00	Black Mountain Ranch L L C
678 684 29 00	0.11	OSP	G	0.00	0.00	\$0.00	\$0.00	Del Sur Community Association
678 684 33 00	1.00	SFD	G	1.00	1.00	\$0.00	\$0.00	Meggors Albert&Ashlea
678 684 34 00	1.00	SFD	G	1.00	1.00	\$0.00	\$0.00	Spic Del Sur Llc
678 685 01 00	1.00	SFD	G	1.00	1.00	\$0.00	\$0.00	Anderson Gregory S
678 685 02 00	1.00	SFD	G	1.00	1.00	\$0.00	\$0.00	Eitzen Christopher J&Catherine I
678 685 03 00	1.00	SFD	G	1.00	1.00	\$0.00	\$0.00	Atwood Michael S&Meredy D
678 685 04 00	1.00	SFD	G	1.00	1.00	\$0.00	\$0.00	Choy Gary T&Merilee G
678 685 05 00	1.00	SFD	G	1.00	1.00	\$0.00	\$0.00	Quayle Steven M&Aubrey T
678 685 06 00	1.00	SFD	G	1.00	1.00	\$0.00	\$0.00	Ramsey Mark R&Stone Jeanne T

EXHIBIT C - Assessment Roll (Fiscal Year 2017)
Black Mountain Ranch North Maintenance Assessment District

Parcel Number	Acres/ Units ⁽¹⁾	Land Use Code ⁽²⁾	Zone	Land Use Factor ⁽²⁾	Total EBUs	Unit Cost (\$/EUBU)	FY 2017 ⁽³⁾ Assessment	Owner Name
678 685 07 00	1.00	SFD	G	1.00	1.00	\$0.00	\$0.00	Seetharamaiah Avinash&Shadan
678 685 08 00	1.00	SFD	G	1.00	1.00	\$0.00	\$0.00	Malayath Narendranath&Pillai Sabitha P
678 685 09 00	1.00	SFD	G	1.00	1.00	\$0.00	\$0.00	Choudhary Ankur&Singh Nitasha
678 685 10 00	1.00	SFD	G	1.00	1.00	\$0.00	\$0.00	Henson Janine
678 685 11 00	1.00	SFD	G	1.00	1.00	\$0.00	\$0.00	Hanson Derek A&Erinn K
678 685 12 00	1.00	SFD	G	1.00	1.00	\$0.00	\$0.00	Ekeroth Daniel&Erin
678 685 13 00	1.00	SFD	G	1.00	1.00	\$0.00	\$0.00	Tan Ty B&Marie T
678 685 14 00	1.00	SFD	G	1.00	1.00	\$0.00	\$0.00	Takenaga Marc M&Chang Michelle
678 685 15 00	1.00	SFD	G	1.00	1.00	\$0.00	\$0.00	Harsch Peter D&Mcvey Lauren B
678 685 16 00	1.00	SFD	G	1.00	1.00	\$0.00	\$0.00	Goodman Seth A&Chan Dana C
678 685 17 00	1.00	SFD	G	1.00	1.00	\$0.00	\$0.00	Spittler-Petersen Family Trust 10-20-14
678 685 18 00	1.00	SFD	G	1.00	1.00	\$0.00	\$0.00	Sibley Family Living Trust 03-13-09
678 685 19 00	1.00	SFD	G	1.00	1.00	\$0.00	\$0.00	Elmen Connie R
678 685 20 00	1.00	SFD	G	1.00	1.00	\$0.00	\$0.00	Hullings Kenneth A Jr&Lori W
678 685 21 00	1.00	SFD	G	1.00	1.00	\$0.00	\$0.00	Mcguire Christopher S&Kristen S
678 685 22 00	1.00	SFD	G	1.00	1.00	\$0.00	\$0.00	Radecic Matthew S&Chelsea A
678 685 23 00	1.00	SFD	G	1.00	1.00	\$0.00	\$0.00	Goldberg Gary&Lori A
678 685 24 00	1.00	SFD	G	1.00	1.00	\$0.00	\$0.00	Bowman Ian E Tr&Forman Selena Tr
678 685 25 00	1.00	SFD	G	1.00	1.00	\$0.00	\$0.00	Mager Michael J&Aimee L
678 685 26 00	1.00	SFD	G	1.00	1.00	\$0.00	\$0.00	Anand Rajeeve M&Primarilyn E
678 685 27 00	1.00	SFD	G	1.00	1.00	\$0.00	\$0.00	Ranka Jinendra&Tripti
678 685 28 00	1.00	SFD	G	1.00	1.00	\$0.00	\$0.00	Wilthee Brett&Krista Family 2013 Trust 12-02-13
678 685 29 00	1.00	SFD	G	1.00	1.00	\$0.00	\$0.00	Chen Woon Hay Paul&Hsieh Pauline Pei-Lan
678 685 30 00	1.00	SFD	G	1.00	1.00	\$0.00	\$0.00	Cariquitan Arvin K&Malonzo-Cariquitan Miriam K
678 685 31 00	1.00	SFD	G	1.00	1.00	\$0.00	\$0.00	Tran John A&Jayne L
678 685 32 00	1.00	SFD	G	1.00	1.00	\$0.00	\$0.00	Sandrew Robert S&Rachel G
678 685 33 00	1.00	SFD	G	1.00	1.00	\$0.00	\$0.00	Black Charles E Jr&Diana D
678 685 34 00	1.00	SFD	G	1.00	1.00	\$0.00	\$0.00	Andrus Curtis L&Nichole
678 685 35 00	1.00	SFD	G	1.00	1.00	\$0.00	\$0.00	He Jianqiang&Qin Yang
678 685 36 00	0.02	OSP	G	0.00	0.00	\$0.00	\$0.00	Black Mountain Ranch L L C
678 686 01 00	1.00	SFD	G	1.00	1.00	\$0.00	\$0.00	Wolff Eric D&Krista M
678 686 02 00	1.00	SFD	G	1.00	1.00	\$0.00	\$0.00	Weston Robert&Fiona
678 686 03 00	1.00	SFD	G	1.00	1.00	\$0.00	\$0.00	Kantor Paola
678 686 04 00	1.00	SFD	G	1.00	1.00	\$0.00	\$0.00	Miranda Luis&Adrianna
678 686 05 00	1.00	SFD	G	1.00	1.00	\$0.00	\$0.00	Dolan Michael J
678 686 06 00	1.00	SFD	G	1.00	1.00	\$0.00	\$0.00	Glavin Daniel J&Nicole
678 686 07 00	1.00	SFD	G	1.00	1.00	\$0.00	\$0.00	Waggoner James F&Perrri Deborah L
678 686 08 00	1.00	SFD	G	1.00	1.00	\$0.00	\$0.00	Diraimo Carol A Revocable Trust 06-26-15
678 686 09 00	1.00	SFD	G	1.00	1.00	\$0.00	\$0.00	Cobb Shawn&Lindsey
678 686 10 00	1.00	SFD	G	1.00	1.00	\$0.00	\$0.00	Herranen Juha&Anu Family 2015 Trust
678 686 11 00	1.00	SFD	G	1.00	1.00	\$0.00	\$0.00	Steinhauser Family Trust 06-11-15
678 686 12 00	1.00	SFD	G	1.00	1.00	\$0.00	\$0.00	Feng Lei&Liu Xin
678 686 13 00	1.00	SFD	G	1.00	1.00	\$0.00	\$0.00	Walker Robert D&Stephanie L
678 686 14 00	1.00	SFD	G	1.00	1.00	\$0.00	\$0.00	Carlson Kevin&Amanda
678 686 15 00	1.00	SFD	G	1.00	1.00	\$0.00	\$0.00	Deverill Eric D Family Trust 06-06-91
678 686 16 00	1.00	SFD	G	1.00	1.00	\$0.00	\$0.00	Bi Yu&Tian Allen
678 686 17 00	1.00	SFD	G	1.00	1.00	\$0.00	\$0.00	Rastogi Pranab&Shikha
678 686 18 00	1.00	SFD	G	1.00	1.00	\$0.00	\$0.00	Beer Family Trust 07-15-14
678 686 19 00	1.00	SFD	G	1.00	1.00	\$0.00	\$0.00	Daley Kevin J&Tracey M
678 686 20 00	1.00	SFD	G	1.00	1.00	\$0.00	\$0.00	Wang Yijie John
678 686 21 00	1.00	SFD	G	1.00	1.00	\$0.00	\$0.00	Xu Yimin&Xiao Ping
678 686 22 00	1.00	SFD	G	1.00	1.00	\$0.00	\$0.00	Goodman Brett B&Julie C Trs
678 686 23 00	1.00	SFD	G	1.00	1.00	\$0.00	\$0.00	Dickey David&Yadira
678 686 24 00	1.00	SFD	G	1.00	1.00	\$0.00	\$0.00	Daga Amit&Nahar Rupal
678 686 25 00	1.00	SFD	G	1.00	1.00	\$0.00	\$0.00	Magnus Richard D&Candice D
678 686 26 00	1.00	SFD	G	1.00	1.00	\$0.00	\$0.00	Pusala Siva P&Manda Nirmala S
678 686 27 00	1.00	SFD	G	1.00	1.00	\$0.00	\$0.00	Megally Sami H&Hanna Silvana S
678 686 28 00	1.00	SFD	G	1.00	1.00	\$0.00	\$0.00	Ward James R&Yuson Chris S
678 686 29 00	1.00	SFD	G	1.00	1.00	\$0.00	\$0.00	Fan Mingxi

EXHIBIT C - Assessment Roll (Fiscal Year 2017)
Black Mountain Ranch North Maintenance Assessment District

Parcel Number	Acres/ Units ⁽¹⁾	Land Use Code ⁽²⁾	Zone	Land Use Factor ⁽²⁾	Total EBUs	Unit Cost (\$/Ebu)	FY 2017 ⁽³⁾ Assessment	Owner Name
678 686 30 00	1.00	SFD	G	1.00	1.00	\$0.00	\$0.00	Marzano Peter L&Solmaz T
678 686 31 00	1.00	SFD	G	1.00	1.00	\$0.00	\$0.00	Veltri Jeffrey B&Stephanie M
678 686 32 00	1.00	SFD	G	1.00	1.00	\$0.00	\$0.00	Muzaffer Mohamed&Valimohideen Zainab
678 686 33 00	1.00	SFD	G	1.00	1.00	\$0.00	\$0.00	Tan Hiang Chuan&Lau Jui Yen
678 686 34 00	1.00	SFD	G	1.00	1.00	\$0.00	\$0.00	Raut Abhay A&Mahalle Asmita P
678 686 35 00	1.00	SFD	G	1.00	1.00	\$0.00	\$0.00	Derringer Jordan S&Jaime E
678 686 36 00	1.00	SFD	G	1.00	1.00	\$0.00	\$0.00	Phung Anthony Van&Melody
678 686 37 00	1.00	SFD	G	1.00	1.00	\$0.00	\$0.00	Vargas Andres&Simon Joanna
678 686 38 00	1.00	SFD	G	1.00	1.00	\$0.00	\$0.00	Sadassivam Suresh K&Ramalingam Uma M
678 686 39 00	1.00	SFD	G	1.00	1.00	\$0.00	\$0.00	Zien Harvey Y&Jade Y
678 686 40 00	1.00	SFD	G	1.00	1.00	\$0.00	\$0.00	Daoud Thair S&Rand
678 686 41 00	1.00	SFD	G	1.00	1.00	\$0.00	\$0.00	Bellam Sasi K
678 686 42 00	1.00	SFD	G	1.00	1.00	\$0.00	\$0.00	Dinesh Jude&Appugounder Kayalvizhi
678 686 43 00	1.00	SFD	G	1.00	1.00	\$0.00	\$0.00	Nelson Family Trust 08-20-08
678 686 44 00	1.00	SFD	G	1.00	1.00	\$0.00	\$0.00	Marcos Ryan&Michelle C
678 686 45 00	1.00	SFD	G	1.00	1.00	\$0.00	\$0.00	Lee Family Trust 08-06-13
678 686 46 00	1.00	SFD	G	1.00	1.00	\$0.00	\$0.00	Hayden Jeremy&Kyla
678 686 47 00	1.00	SFD	G	1.00	1.00	\$0.00	\$0.00	Ko Young Hwan&Seo Eunjung
678 686 48 00	1.00	SFD	G	1.00	1.00	\$0.00	\$0.00	Cui Yang&Zhang Qing
678 686 49 00	1.00	SFD	G	1.00	1.00	\$0.00	\$0.00	Blankenship Tom A&Julie A
678 686 50 00	1.25	OSP	G	0.00	0.00	\$0.00	\$0.00	Del Sur Community Association
678 686 51 00	0.22	OSP	G	0.00	0.00	\$0.00	\$0.00	Del Sur Community Assn
678 686 52 00	0.12	OSP	G	0.00	0.00	\$0.00	\$0.00	Del Sur Community Assn
678 686 53 00	0.02	OSP	G	0.00	0.00	\$0.00	\$0.00	Black Mountain Ranch L L C
678 686 54 00	1.73	OSP	G	0.00	0.00	\$0.00	\$0.00	Del Sur Community Assn
678 686 55 00	0.08	OSP	G	0.00	0.00	\$0.00	\$0.00	Del Sur Community Assn
678 686 56 00	0.04	OSP	G	0.00	0.00	\$0.00	\$0.00	Del Sur Community Association
678 686 57 00	0.07	STR	G	0.00	0.00	\$0.00	\$0.00	Del Sur Community Assn
678 686 58 00	0.15	STR	G	0.00	0.00	\$0.00	\$0.00	Del Sur Community Assn
678 686 59 00	0.16	STR	G	0.00	0.00	\$0.00	\$0.00	Del Sur Community Assn
678 686 60 00	1.43	STR	G	0.00	0.00	\$0.00	\$0.00	Black Mountain Ranch L L C
678 686 61 00	1.80	OSP	G	0.00	0.00	\$0.00	\$0.00	Del Sur Community Association
678 687 01 00	1.00	SFD	G	1.00	1.00	\$0.00	\$0.00	Dietrich George R&Nancy A Family Living Trust 06-28-05
678 687 02 00	1.00	SFD	G	1.00	1.00	\$0.00	\$0.00	Mercer Garrett J&Dumont Lena
678 687 03 00	1.00	SFD	G	1.00	1.00	\$0.00	\$0.00	Stiles Wolfgang&Shirley S
678 687 04 00	1.00	SFD	G	1.00	1.00	\$0.00	\$0.00	Mishra Saurabh&Hemlata
678 687 05 00	1.00	SFD	G	1.00	1.00	\$0.00	\$0.00	Springer Devon
678 687 06 00	1.00	SFD	G	1.00	1.00	\$0.00	\$0.00	Fusco Angela&Anthony Living Trust 06-13-14
678 687 07 00	1.00	SFD	G	1.00	1.00	\$0.00	\$0.00	Jelensky Kevin J&Angelina M
678 687 08 00	1.00	SFD	G	1.00	1.00	\$0.00	\$0.00	Rubenstein Michael&Alexi
678 687 09 00	1.00	SFD	G	1.00	1.00	\$0.00	\$0.00	Fischer Mark A&Carolyn M Family Trust 11-28-95
678 687 10 00	1.00	SFD	G	1.00	1.00	\$0.00	\$0.00	Huckabay Evan M
678 687 11 00	1.00	SFD	G	1.00	1.00	\$0.00	\$0.00	Lim Junior&Hong Annie
678 687 12 00	1.00	SFD	G	1.00	1.00	\$0.00	\$0.00	Ikeda Naomi C
678 687 13 00	1.00	SFD	G	1.00	1.00	\$0.00	\$0.00	Kennedy Ryan W&Jennifer
678 687 14 00	1.00	SFD	G	1.00	1.00	\$0.00	\$0.00	Mishra Chinmaya&Misra Rasmita
678 687 15 00	1.00	SFD	G	1.00	1.00	\$0.00	\$0.00	Adolpho Isaac&Rachelle D
678 687 16 00	1.00	SFD	G	1.00	1.00	\$0.00	\$0.00	Hwang Insoo&Kim Jinyoung
678 687 17 00	1.00	SFD	G	1.00	1.00	\$0.00	\$0.00	Cruz Evan M E&Cac Catherine T
678 687 18 00	1.00	SFD	G	1.00	1.00	\$0.00	\$0.00	Gregory Roger&Tracey
678 687 19 00	1.00	SFD	G	1.00	1.00	\$0.00	\$0.00	Patrawala Neville&Urvisha D
678 687 20 00	1.00	SFD	G	1.00	1.00	\$0.00	\$0.00	Lynch John C&Charlene O
678 687 21 00	1.00	SFD	G	1.00	1.00	\$0.00	\$0.00	Thompson Terry L&Dawn M
678 687 22 00	0.04	OSP	G	0.00	0.00	\$0.00	\$0.00	Black Mountain Ranch L L C
678 690 01 00	7.74	IND	F	15.00	116.10	\$0.00	\$0.00	Black Mountain Ranch L L C
678 690 02 00	6.53	IND	F	15.00	97.95	\$0.00	\$0.00	Black Mountain Ranch L L C
678 690 03 00	4.34	IND	F	15.00	65.10	\$0.00	\$0.00	Black Mountain Ranch L L C
678 690 06 00	2.29	COM	F	45.00	103.05	\$0.00	\$0.00	Del Sur Tc Llc
678 690 07 00	1.76	COM	F	45.00	79.20	\$0.00	\$0.00	Del Sur Tc Llc

EXHIBIT C - Assessment Roll (Fiscal Year 2017)
Black Mountain Ranch North Maintenance Assessment District

Parcel Number	Acres/ Units ⁽¹⁾	Land Use Code ⁽²⁾	Zone	Land Use Factor ⁽²⁾	Total EBUs	Unit Cost (\$/EUBU)	FY 2017 ⁽³⁾ Assessment	Owner Name
678 690 08 00	1.74	COM	F	45.00	78.30	\$0.00	\$0.00	Black Mountain Ranch L L C
678 690 09 00	1.57	COM	F	45.00	70.65	\$0.00	\$0.00	Black Mountain Ranch L L C
678 690 12 00	6.00	MFR	F	0.70	4.20	\$0.00	\$0.00	Black Mountain Ranch L L C
678 690 13 00	6.00	MFR	F	0.70	4.20	\$0.00	\$0.00	Black Mountain Ranch L L C
678 690 14 00	11.00	MFR	F	0.70	7.70	\$0.00	\$0.00	Black Mountain Ranch L L C
678 690 15 00	11.00	MFR	F	0.70	7.70	\$0.00	\$0.00	Black Mountain Ranch L L C
678 690 16 00	8.00	MFR	F	0.70	5.60	\$0.00	\$0.00	Black Mountain Ranch L L C
678 690 17 00	8.00	MFR	F	0.70	5.60	\$0.00	\$0.00	Black Mountain Ranch L L C
678 690 18 00	6.00	MFR	F	0.70	4.20	\$0.00	\$0.00	Black Mountain Ranch L L C
678 690 19 00	6.00	MFR	F	0.70	4.20	\$0.00	\$0.00	Black Mountain Ranch L L C
678 690 24 00	24.00	MFR	G	0.70	16.80	\$0.00	\$0.00	Black Mountain Ranch L L C
678 690 25 00	2.20	COM	G	45.00	99.00	\$0.00	\$0.00	Black Mountain Ranch L L C
678 690 25 00	20.00	MFR	G	0.70	14.00	\$0.00	\$0.00	Black Mountain Ranch L L C
678 690 26 00	3.76	COM	G	45.00	169.20	\$0.00	\$0.00	Black Mountain Ranch L L C
678 690 27 00	0.17	OSP	F	0.00	0.00	\$0.00	\$0.00	Black Mountain Ranch L L C
678 690 28 00	0.23	UTL	F	3.00	0.69	\$0.00	\$0.00	Black Mountain Ranch L L C
678 690 29 00	10.42	COM	F	45.00	468.90	\$0.00	\$0.00	Target Corporation
678 690 30 00	1.26	COM	F	45.00	56.70	\$0.00	\$0.00	Del Sur Tc Llc
678 690 31 00	0.98	COM	F	45.00	44.10	\$0.00	\$0.00	Del Sur Tc Llc
678 690 32 00	2.38	COM	F	45.00	107.10	\$0.00	\$0.00	Del Sur Tc Llc
678 690 34 01	1.00	CND	G	0.70	0.70	\$0.00	\$0.00	Clark Craig S&Amy R
678 690 34 02	1.00	CND	G	0.70	0.70	\$0.00	\$0.00	Gutierrez Rogelio Jr&Jeanette P
678 690 34 03	1.00	CND	G	0.70	0.70	\$0.00	\$0.00	Moore Orlander V
678 690 34 04	1.00	CND	G	0.70	0.70	\$0.00	\$0.00	Yutangco Geoff R&Angela J T
678 690 34 05	1.00	CND	G	0.70	0.70	\$0.00	\$0.00	Mundlapudi Sraavan R
678 690 35 01	1.00	CND	G	0.70	0.70	\$0.00	\$0.00	Alegre Joseph&Jessica
678 690 35 02	1.00	CND	G	0.70	0.70	\$0.00	\$0.00	Kim Mike&Virginia
678 690 35 03	1.00	CND	G	0.70	0.70	\$0.00	\$0.00	Bernard Stephanie
678 690 35 04	1.00	CND	G	0.70	0.70	\$0.00	\$0.00	Presnell James M
678 690 35 05	1.00	CND	G	0.70	0.70	\$0.00	\$0.00	Tran Rick T&Karen Y
678 690 36 01	1.00	CND	G	0.70	0.70	\$0.00	\$0.00	Little John K&Tara R
678 690 36 02	1.00	CND	G	0.70	0.70	\$0.00	\$0.00	Jolians Farms Lc
678 690 36 03	1.00	CND	G	0.70	0.70	\$0.00	\$0.00	Spic Del Sur Llc
678 690 36 04	1.00	CND	G	0.70	0.70	\$0.00	\$0.00	Yang Shu Ji&Mai Guo Qun
678 690 38 01	1.00	CND	G	0.70	0.70	\$0.00	\$0.00	Spic Del Sur Llc
678 690 38 02	1.00	CND	G	0.70	0.70	\$0.00	\$0.00	Moore Ryan&Lisa M
678 690 38 03	1.00	CND	G	0.70	0.70	\$0.00	\$0.00	Patti Christopher J&Liu Xinmei
678 690 38 04	1.00	CND	G	0.70	0.70	\$0.00	\$0.00	Nimbalker Adhish&Jahagirdar Manasi
678 690 38 05	1.00	CND	G	0.70	0.70	\$0.00	\$0.00	Whelan Kent F&Sherylee O
678 690 39 01	1.00	CND	G	0.70	0.70	\$0.00	\$0.00	Arbuckle James F&Natalie D Revocable Living Trust 03-28-11
678 690 39 02	1.00	CND	G	0.70	0.70	\$0.00	\$0.00	Tanner Robert M Iii&Melissa A
678 690 39 03	1.00	CND	G	0.70	0.70	\$0.00	\$0.00	Nguyen Anthony H
678 690 39 04	1.00	CND	G	0.70	0.70	\$0.00	\$0.00	Vinson Andrea J
678 690 39 05	1.00	CND	G	0.70	0.70	\$0.00	\$0.00	Punzalan Jason&Candice
678 690 39 06	1.00	CND	G	0.70	0.70	\$0.00	\$0.00	Torbert Jason&Alexis
678 690 40 01	1.00	CND	G	0.70	0.70	\$0.00	\$0.00	Spic Del Sur Llc
678 690 40 02	1.00	CND	G	0.70	0.70	\$0.00	\$0.00	Spic Del Sur Llc
678 690 40 03	1.00	CND	G	0.70	0.70	\$0.00	\$0.00	Spic Del Sur Llc
678 690 40 04	1.00	CND	G	0.70	0.70	\$0.00	\$0.00	Spic Del Sur Llc
678 690 41 00	14.00	CND	G	0.70	9.80	\$0.00	\$0.00	Spic Del Sur Llc
678 691 03 00	1.80	PKU	G	0.50	0.90	\$0.00	\$0.00	Black Mountain Ranch L L C
678 691 04 00	13.84	PKU	G	0.50	6.92	\$0.00	\$0.00	Black Mountain Ranch L L C
678 691 05 01	1.00	CND	G	0.70	0.70	\$0.00	\$0.00	Crick John E&Elaine M
678 691 05 02	1.00	CND	G	0.70	0.70	\$0.00	\$0.00	Roston Eryn&Trisha
678 691 05 03	1.00	CND	G	0.70	0.70	\$0.00	\$0.00	Holland Deandra
678 691 05 04	1.00	CND	G	0.70	0.70	\$0.00	\$0.00	Bartz Albert L&Ikeda Ayako
678 691 06 01	1.00	CND	G	0.70	0.70	\$0.00	\$0.00	Huang Meixia
678 691 06 02	1.00	CND	G	0.70	0.70	\$0.00	\$0.00	Roach Daniel
678 691 06 03	1.00	CND	G	0.70	0.70	\$0.00	\$0.00	Moore Jared P&Meghan M

EXHIBIT C - Assessment Roll (Fiscal Year 2017)
Black Mountain Ranch North Maintenance Assessment District

Parcel Number	Acres/ Units ⁽¹⁾	Land Use Code ⁽²⁾	Zone	Land Use Factor ⁽²⁾	Total EBUs	Unit Cost (\$/EUBU)	FY 2017 ⁽³⁾ Assessment	Owner Name
678 691 06 04	1.00	CND	G	0.70	0.70	\$0.00	\$0.00	Kang Hoseok&Yu Hyunjung
678 691 07 01	1.00	CND	G	0.70	0.70	\$0.00	\$0.00	Enrique Greg M
678 691 07 02	1.00	CND	G	0.70	0.70	\$0.00	\$0.00	Yang Su&Cheung Yuen Ting
678 691 07 03	1.00	CND	G	0.70	0.70	\$0.00	\$0.00	Lederer Family Trust 08-29-02
678 691 07 04	1.00	CND	G	0.70	0.70	\$0.00	\$0.00	Tang Crystal C Revocable Trust 08-31-07
678 691 09 01	1.00	CND	G	0.70	0.70	\$0.00	\$0.00	Kiviat Douglas&Jane Trust 09-30-13
678 691 09 02	1.00	CND	G	0.70	0.70	\$0.00	\$0.00	Reynoso Michael A&Anna M
678 691 09 03	1.00	CND	G	0.70	0.70	\$0.00	\$0.00	Chen Alan Hsiang-Shang&Cheng Catherine
678 691 09 04	1.00	CND	G	0.70	0.70	\$0.00	\$0.00	Jerome John R&Sarah M
678 691 10 01	1.00	CND	G	0.70	0.70	\$0.00	\$0.00	Sachdeva Rajan K
678 691 10 02	1.00	CND	G	0.70	0.70	\$0.00	\$0.00	Ali Amro&Angela
678 691 10 03	1.00	CND	G	0.70	0.70	\$0.00	\$0.00	Lemaster Jonathan R
678 691 10 04	1.00	CND	G	0.70	0.70	\$0.00	\$0.00	Hillman Marguerite Living Trust 05-17-01
678 691 10 05	1.00	CND	G	0.70	0.70	\$0.00	\$0.00	Kung Christopher C
678 691 11 01	1.00	CND	G	0.70	0.70	\$0.00	\$0.00	Yu Pengying
678 691 11 02	1.00	CND	G	0.70	0.70	\$0.00	\$0.00	Subroto Fransiska
678 691 11 03	1.00	CND	G	0.70	0.70	\$0.00	\$0.00	Guan Rong Da&Ruihong
678 691 11 04	1.00	CND	G	0.70	0.70	\$0.00	\$0.00	Anderson Andrew J
678 691 11 05	1.00	CND	G	0.70	0.70	\$0.00	\$0.00	Shewry Steven&Judith M
678 691 12 00	0.41	STR	G	0.00	0.00	\$0.00	\$0.00	Spic Del Sur Llc
678 700 01 00	259.00	CND	H	0.70	181.30	\$0.00	\$0.00	S P I C Del Sur Llc
678 700 02 00	0.87	OSP	H	0.00	0.00	\$0.00	\$0.00	S P I C Del Sur Llc
678 700 03 00	1.28	OSP	H	0.00	0.00	\$0.00	\$0.00	S P I C Del Sur Llc
678 700 04 00	0.22	OSP	H	0.00	0.00	\$0.00	\$0.00	S P I C Del Sur Llc
678 700 05 00	2.38	OSP	H	0.00	0.00	\$0.00	\$0.00	S P I C Del Sur Llc
678 700 06 00	4.05	OSP	H	0.00	0.00	\$0.00	\$0.00	S P I C Del Sur Llc
678 701 01 00	1.20	STR	H	0.00	0.00	\$0.00	\$0.00	S P I C Del Sur Llc
678 701 02 00	28.11	OSP	H	0.00	0.00	\$0.00	\$0.00	S P I C Del Sur Llc
678 701 03 00	17.22	OSP	H	0.00	0.00	\$0.00	\$0.00	S P I C Del Sur Llc
TOTAL	-	-	-	-	5,102.21	-	\$0	

⁽¹⁾ Applicable units (acres or dwelling units) dependent upon Land Use Code

⁽²⁾ Refer to Assessment Engineer's Report for descriptions of Land Use Code and Land Use Factor.

⁽³⁾ FY 2017 is the City's Fiscal Year 2017, which begins July 1, 2016 and ends June 30, 2017