



Recycled Water Study

Prepared for

City of San Diego

July 2012

SAN DIEGO RECYCLED WATER STUDY

Prepared for
City of San Diego, Public Utilities Department
July 2012

Project No. 137921



Victor Occiano, P.E., Brown and Caldwell
CA C63566, EXP 9/30/2012

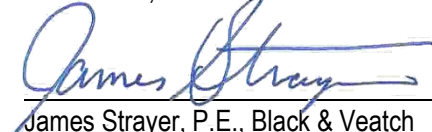

James Strayer, P.E., Black & Veatch
CA C56943, EXP 6/30/2013



This page intentionally left blank.

Preface

This Recycled Water Study is the culmination of a two year process to develop a new vision for water reuse in the San Diego region. The Study's alternatives were developed through a participatory process involving work sessions and Stakeholder meetings. The combined contributions of the Stakeholders were invaluable in developing alternatives that considered diverse perspectives, concepts and approaches. The culmination of the Stakeholder efforts included a Study review workshop, held on March 22, 2012. At the conclusion of the workshop, attendees were complimentary of the Study process and supportive of the content included in this Report. This page recognizes the efforts of the Stakeholder participants that contributed substantially to this effort.

Stakeholders



Bruce Bell, Ph.D., P.E.
Independent Technical Consultant

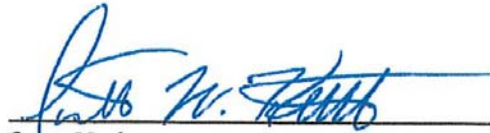

Scott Huth
Metropolitan Wastewater Joint Powers Authority



Julia Chunn-Heer
Surfrider Foundation, San Diego Chapter

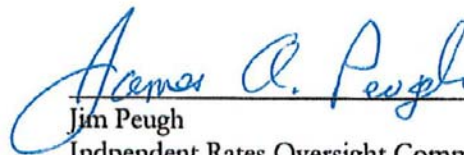

Jim Peugh
Independent Rates Oversight Committee (IROC)

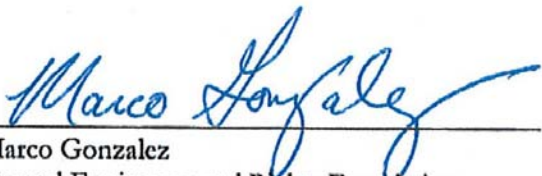

Marco Gonzalez
Coastal Environmental Rights Foundation



Toby Roy
San Diego County Water Authority

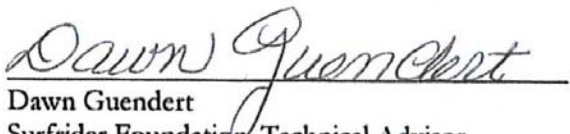

Dawn Guendert
Surfrider Foundation, Technical Advisor

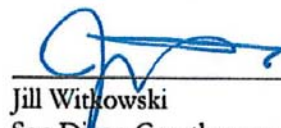

Jill Witkowski
San Diego Coastkeeper



This page intentionally left blank.

What Are Key Terms Used in this Study?

The following key terms are defined due to their frequent use and their importance in understanding the concepts involved in this Study. A more comprehensive glossary is included in the Study.

Water Reuse: Water reuse is a broad term used to describe the process of converting wastewater to a valuable water resource through treatment processes. Water reuse includes non-potable recycled water development and indirect potable reuse involving integration with drinking water supplies.

Non-potable Recycled Water: Synonymous with Non-potable Reclaimed Water, State of California Title 22 Water, and tertiary treated water. Non-potable recycled water is a form of water reuse that includes primary, secondary and tertiary treatment to produce water suitable for a variety of applications, most notably for landscaping irrigation and industrial uses. Further treatment is required for integration with drinking water systems – see indirect potable reuse.

Purified, Advanced Purified, or Advanced Treated Water: Purified, advanced purified, or advanced treated water undergoes advanced treatment processes to convert non-potable recycled water to a highly purified water quality, suitable for augmentation to an untreated drinking water source. Advanced purified water is currently used for indirect potable reuse projects.

Indirect Potable Reuse: Indirect potable reuse is the planned use of advanced purified water for replenishment of a groundwater basin or an aquifer that has been designated as a source of water supply for a public water system, or the planned placement of recycled water into a surface water reservoir used as a source of domestic drinking water supply.

Direct Potable Reuse: The planned introduction of advanced purified water either directly into a public water system, or into an untreated water supply, immediately upstream of a water treatment plant.

Wastewater: Wastewater is generally used to describe sewage that comes from homes, industry or businesses. Wastewater is collected and treated at wastewater treatment plants. In San Diego, some wastewater is currently reclaimed as non-potable recycled water; however, the majority is treated and discharged to the ocean. Wastewater is needed for water reuse. Wastewater does not include stormwater in San Diego. Stormwater is collected in separate systems and typically not treated before discharge to streams and the ocean.

Uninterruptible Water Supply: Indirect potable reuse water is considered uninterruptible because it is not influenced by drought, water rights, or other supply interruptions such as the decision to decrease Southern California water supply because of endangered species in the California Bay-Delta.

Untreated Water (sometimes referred to as Raw Water): Water that is collected and stored in local surface water reservoirs and groundwater basins prior to treatment at a potable (drinking) water treatment plant. Untreated water examples include Colorado River water, water from the California Bay-Delta, and runoff from local rainfall.

Potable or Drinking Water: Potable water is water that meets the EPA's Safe Water Drinking Act and California Water Code requirements. Residents and businesses receive potable water at their water meter connection, and its use is unrestricted.



This page intentionally left blank.

SAN DIEGO RECYCLED WATER STUDY

EXECUTIVE SUMMARY

Background

In August 2009, the City of San Diego (City), along with key stakeholders, initiated the Recycled Water Study (Study) as part of a Cooperative Agreement (included in Appendix A) between the City and two environmental groups. This Study is intended to serve as a guidance document in helping policy leaders make the important decisions ahead regarding water reuse and the region's water and wastewater infrastructure.

Why Is Water Reuse Important to San Diego?

Water is important to the health, safety, and quality of life of people living in the San Diego region.

Historically, the region's 3.1 million residents have received a majority of their water supply from imported sources, including the California Bay-Delta (Bay-Delta) and the Colorado Rivers (conveyed via the California Aqueduct and the Colorado River Aqueduct, respectively). Currently, 80 percent of the San Diego region's water supply is imported. Local supplies and conservation account for the remaining 20 percent of the total supply. The region's reliance on imported water causes San Diego's water supply to be vulnerable to impacts from shortages and susceptible to price increases. In 2008, water supplied from the Bay-Delta was restricted to protect endangered fish species. In addition, drought conditions in Southern California further impacted water supply availability. With the region's population projected to reach 3.9 million people by 2030, demands will increase and strain these limited water supplies. Water reuse has been proven as a safe, reliable, locally controlled and sustainable option for the region.



Water Reuse in San Diego. Water reuse is an important component in San Diego's water supply portfolio.

What Other Drivers Affected this Study?

In 2010, the United States (U.S.) Environmental Protection Agency (EPA) allowed the City to continue to operate the Point Loma Wastewater Treatment Plant (Point Loma Plant) as a chemically enhanced primary treatment facility under a modification to its National Pollutant Discharge Elimination System (NPDES) Permit. The 2010 permit allows the City to operate in this fashion for five years until 2015, when the permit must be renewed. During the 2008-2010 permit modification process, two environmental organizations entered into a Cooperative Agreement with the City to conduct this Recycled Water Study. In accordance with the Cooperative Agreement, both of these organizations provided their support to the U.S. EPA's decision to grant the modification. The City's responsibility per the Cooperative Agreement is to execute this Study, which is also consistent with the City's long-term goals and objectives.

Water reuse programs provide valuable water supplies by using resources that otherwise are sent to the ocean. The decisions to invest in a water reuse program, or alternative large-scale wastewater system upgrades, will affect the rates, reliability, and regional assets for decades. The fundamental focus of this study was to develop water reuse alternatives and then weigh the alternatives against other options – with particular focus on the water supply benefits and the cost savings through reduced wastewater systems operations and improvements.



Recycled Water Study Chapter Summary

Chapter 1

Study Overview. Provides background and objectives of the San Diego Recycled Water Study, as well as describes the Study process and defines participating Stakeholders and Team Members, Study components, and important terminology used throughout the Study.

Chapter 2

Water Reuse Need and Related Activities. Presents the dynamic water supply conditions in San Diego and the opportunity to implement water reuse as a local supply through related key studies and activities such as the 2005 Water Reuse Study and 2010 Recycled Water Master Plan Update.

Chapter 3

Study Process and Evaluation Approach. Describes, in detail, the elements of the participatory Study process and defines the guidelines and criteria against which the potential recycled water opportunities were assessed.

Chapter 4

Key Facilities, Water Demands and Wastewater Flows. Summarizes the principal elements of San Diego's current water, wastewater, and recycled water infrastructure systems that impact water reuse planning, and provides the related demands and flows from these systems.

Chapter 5

Non-potable Recycled Water Opportunities. Describes the technical basis and foundation for developing the non-potable recycled water opportunities that were considered, such as existing and future demands, seasonal considerations, and locations and capacities of existing water recycling facilities.

Chapter 6

Indirect Potable Reuse Opportunities. Describes the technical basis and foundation for developing the indirect potable reuse opportunities that were considered in the Study, including reservoir augmentation and groundwater recharge, and other potential benefits of indirect potable reuse.

Chapter 7

Area Concepts. Provides detailed, comparable options, including both non-potable recycled water opportunities and indirect potable reuse opportunities, to develop comprehensive water reuse plans within three key Study areas.

Chapter 8

Integrated Reuse Alternatives. Evaluates the water reuse concepts presented in Chapter 7 based on Study goals, as well as provides a comparable financial evaluation for key alternatives, including a description of the financial model and its components.

Chapter 9

Study Outreach and Approvals. Describes the Study presentations given to stakeholder groups and approving bodies.

Supporting Material Summary

GLOSSARY	Defines important terminology and acronyms used throughout the Study.
APPENDIX A	Cooperative Agreement. Provides a copy of the signed agreement between the City of San Diego, the San Diego Coastkeeper, and the San Diego Chapter of the Surfrider Foundation to conduct a Recycled Water Study.
APPENDIX B	Point Loma Plant Conclusions. Provides data and conclusions on the Point Loma Plant based on the results of the Study, including an allocation of flows, discussion on chemically enhanced primary treatment, and projected 2050 mass emission rates under various scenarios.
APPENDIX C	Summary of Regulations That Affect Water, Wastewater and Recycled Water. Provides an overview of the key regulatory considerations for water, recycled water and wastewater, and includes anticipated regulatory criteria related to indirect potable reuse sizing.
APPENDIX D	California Senate Bill 918. Provides background on State of California Department of Public Health requirements for developing uniform criteria for groundwater recharge, reservoir augmentation and direct potable reuse.
APPENDIX E	Siting Analysis Documents. Provides siting information on the Harbor Drive, Camino del Rio and Morena sites, City ownership, and an alternatives analysis performed by the City.
APPENDIX F	Conceptual Cost Estimates for the Integrated Reuse Alternatives. Provides infrastructure sizing and costs for each Integrated Reuse Alternative component.
APPENDIX G	National Water Resource Institute (NWRI) White Paper On Direct Potable Reuse
APPENDIX H	Recycled Water Study Cost Methodology FAQ. An informative, frequently asked question (FAQ) style document on how the direct and indirect wastewater cost reductions/credits/savings were calculated.
APPENDIX I	Participating Agency White Paper on Reuse Concepts
APPENDIX J	Comment/Response Form. Provides responses to Stakeholder comments made during the Study.
APPENDIX K	Conceptual Metro System Flow Schematics. Graphics showing the reuse alternatives and accounting of flows throughout the system.
APPENDIX L	Metro JPA Letter
APPENDIX M	City Council Resolution



How Does This Study Fit into Other On-going Efforts?

The overarching objective of this Study is to develop and clearly present integrated reuse alternatives that the public and policy-makers can review and select from to guide the future of the reuse program located within the Metropolitan Sewerage System Service Area. The alternatives were evaluated to meet City, Participating Agency, and Project Stakeholder reuse goals through a 2035 planning horizon. This Study is one part of a comprehensive regional program to evaluate and develop water reuse in San Diego.

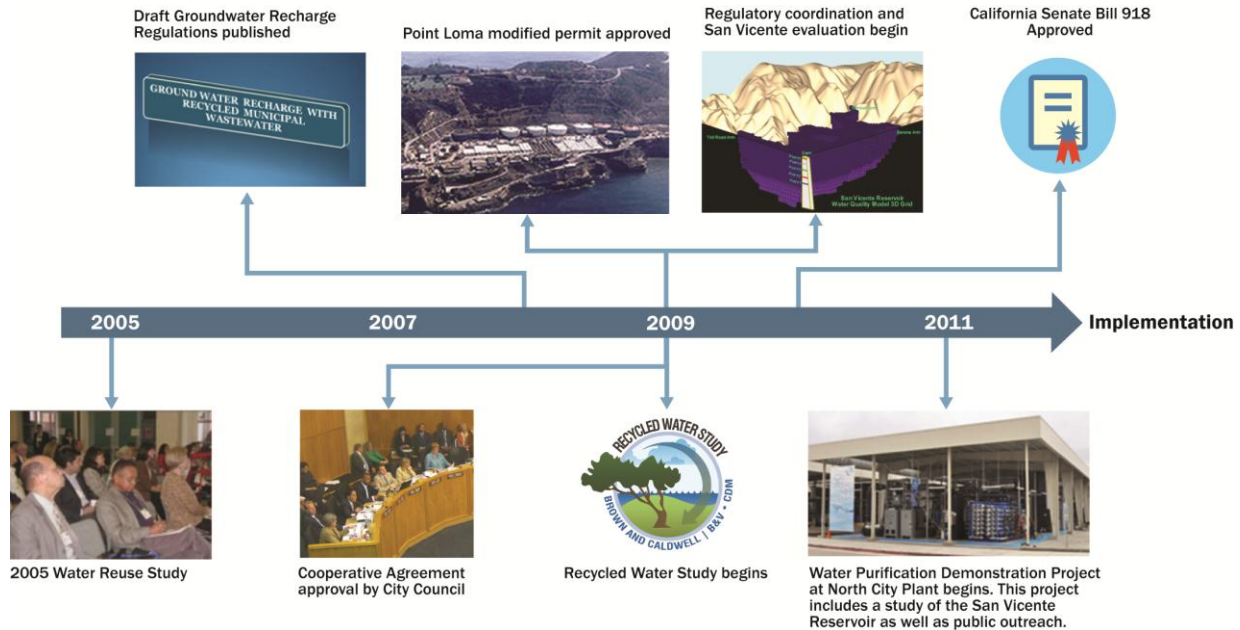

Who Participated in the Study?

The Stakeholders for this Project are comprised of the San Diego Coastkeeper, the San Diego Chapter of the Surfrider Foundation, and the Participating Agencies of the Metropolitan Wastewater Joint Power Authority (Metro JPA), who have capacity rights in the Metropolitan Sewerage System pursuant to the provisions of the 1998 *Regional Wastewater Disposal Agreement Between the City of San Diego and the Participating Agencies in the Metropolitan Sewerage System*. The San Diego County Water Authority (SDCWA), the agency that has primary responsibility for water supply planning efforts, and the Independent Rates Oversight Committee, are also Stakeholders in the Study. The primary Project Team consisted of City staff from the Public Utilities Department and a consulting team from Brown and Caldwell, Black & Veatch, and CDM.

PROJECT STAKEHOLDERS

- Environmental Groups**
 - San Diego Coastkeeper
 - Surfrider Foundation, San Diego Chapter
- Oversight Groups**
 - Independent Rates Oversight Committee (IROC)
- Regional Water Supplies**
 - San Diego County Water Authority (SDCWA)
- Participating Agency Members**
 - City of Chula Vista
 - City of Coronado
 - City of Del Mar
 - City of El Cajon
 - City of Imperial Beach
 - City of La Mesa
 - City of National City
 - City of Poway
 - Lemon Grove Sanitation District
 - Otay Water District
 - Padre Dam Municipal Water District
 - San Diego County Sanitation District
 - Alpine Sanitation District
 - Lakeside Sanitation District
 - Spring Valley Sanitation District
 - Winter Gardens Sewer Maintenance District



What Was the Study Process?

The Study includes a number of technical evaluations and coordination steps to identify and evaluate reuse alternatives within the City as well as areas served by the Participating Agencies. Throughout the Study, regular Stakeholder Status Update Meetings were held to present progress and to receive input and feedback on the activities. Eight technical memoranda were developed to document information.

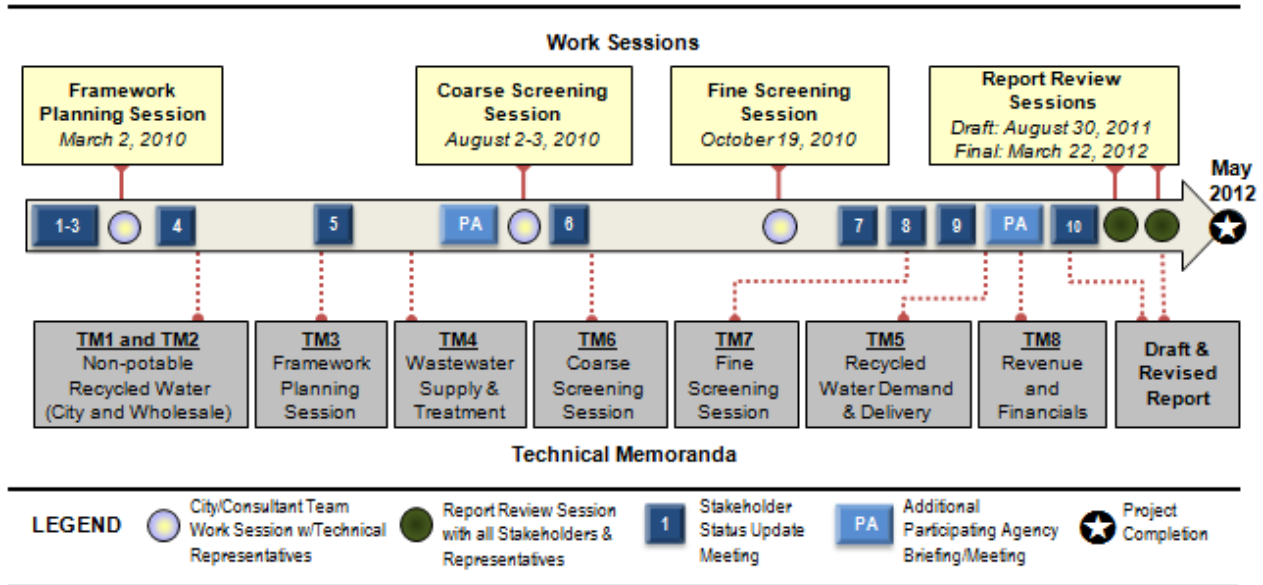

How Were Alternatives Developed?

Alternatives were developed through a participatory process. Stakeholder Status Update Meetings and five work sessions were used to frame, develop, refine, and communicate the Alternatives included in this Study.



Work Sessions. The Coarse Screening and Fine Screening Sessions included presentations, team exercises, and facilitated discussions. The sessions leveraged the group’s creativity and diverse perspectives to improve the quality of the Alternatives presented in the Study.

What Issues and Opportunities Helped Determine the Water Reuse Target?

The water reuse target, similar to past efforts, was based on Study goals, Stakeholders' input, and findings from technical analyses. The goal of the 2005 Water Reuse Study was to maximize the available capacities at the North City and South Bay Plants, which coincided with a target of approximately 20 mgd for future water reuse projects. This 2012 Study was initiated with a broader basis: to consider the water reuse goal to be limited *only* by the amount of wastewater available in the Metro Service Area. This is a more comprehensive goal, providing the potential to reuse ten times more water than previous targets, with approximately 200 mgd projected to be available in the Metro Service Area on an average dry weather year in 2035. During the Study, the following four measures evolved as primary drivers for establishing the water reuse target:

Measure 1: Value of Water. Multiple forces are driving water reuse in Southern California. Water reuse projects produce high-quality, reliable, uninterrupted local water to the region, serving the same purpose as imported untreated water. Imported untreated water rates will continue to rise, and conveyance system improvements will be needed to deliver imported water to the region's water treatment plants - unless the supply is supplemented with new local supplies. Indirect potable reuse can fulfill this need and, over time, do so at lower costs – especially when reduced capital and operating costs at the Point Loma Plant are considered. Savings would likely increase further if the regulatory framework for Direct Potable Reuse is finalized, allowing direct delivery to the region's potable water treatment plants. Based on these considerations, the reuse target for this study, especially the indirect potable reuse portion, should be maximized.

Measure 2: Water Quality Benefits. Two water quality considerations were taken into account in establishing a water reuse target: ocean water quality and imported water salinity. Both are important, and both would be significantly improved through implementation of the water reuse projects identified in this Study. For example, blending advanced purified water with imported water in San Vicente Reservoir and Otay Lakes could reduce salinity levels by 50 percent. On land, the reservoirs that receive the advanced purified water, the residents that use the water, and the soil that is irrigated with the water would all benefit from having water with up to half the current salinity levels. Residents would benefit from softer water and extended lives of household appliances such as water heaters, dishwashers, clothes washers and faucets. Ocean water quality would also improve by removing and diverting solids to the Metropolitan Biosolids Center. Based on these considerations, the water reuse target for this Study should be maximized.

Measure 3: Beneficial Project Size versus Costs. Project sizing was considered a limiting factor in developing the water reuse target. Non-potable recycled water projects, while beneficial for targeted areas (such as Otay Water District's planned system expansion), did not have enough demand potential to use a substantial portion of the available wastewater. It also became apparent that developing indirect potable reuse projects to use all wastewater available in the Metro System would not be practical or provide the right balance of costs and benefits. Therefore, the water reuse target based on project constraints and permit considerations was approximately 80 to 120 mgd (upper end based on estimated regulatory flow limits to the San Vicente Reservoir in conjunction with the South Bay Spring Valley No. 8 Diversion).

Four Measures that Established the Water Reuse Target:

- **Measure 1: Value of Water.** Reliable water supplies are needed for San Diego.
- **Measure 2: Water Quality.** Reuse can improve the ocean water quality. Indirect potable reuse can significantly reduce salinity levels benefiting ratepayers.
- **Measure 3: Project Size vs. Costs.** Water reuse targets should be based on project sizing that considers costs and regulatory limits.
- **Measure 4: Reuse Program Induced Savings.** The water reuse program sizing should consider reduced capital and operating costs in the drinking water and wastewater systems.

Measure 4: Reuse Program-Induced Savings, Offsets. San Diego has the potential to create a valuable new water supply cost effectively due to the reuse program's benefit of reducing capital and operating costs in the downstream wastewater system and water quality improvements benefitting the water systems. The largest cost savings generated by the reuse program is reduced capital and operational costs at the Point Loma Plant. Leading up to the Fine Screening Sessions, a reuse target of approximately 100 mgd was established to achieve cost savings by avoiding certain upgrades at the Point Loma Plant. At 100 mgd, and based on dry weather flows, certain treatment processes were avoided. This target was later re-evaluated against a scenario in the City's September 2011 Draft Wastewater Master Plan that included a 10-year wet weather return flow event in establishing 2050 annual average daily flows. While the specific upgrades at the Point Loma Plant and the diversions to South Bay changed when coordinated with the September 2011 Draft Wastewater Master Plan, the Integrated Reuse Alternative costs remained relatively unaffected, and therefore no changes to the Alternatives were made.



Savings at the Point Loma Plant. Savings at the Point Loma Plant played an important role in establishing reuse targets. The land available at Point Loma Site is constrained, and any upgrades incur high costs.

Cost Methodology

A detailed financial evaluation was performed for each Integrated Reuse Alternative considered in this Study. The financial evaluation was prepared to ultimately help decision-makers compare the costs of different water reuse approaches and to aid in making decisions about whether to invest in the water reuse system. The guiding principles for the evaluation included:

Transparency. Provide transparent costing of alternatives.

Input and Access. Provide multiple opportunities at workshops and Stakeholder meetings to review, discuss, and debate project costs.

Comparative and Comprehensive Alternatives Costs. Prepare a comparative financial evaluation of the Integrated Reuse Alternatives and include financing costs.

Cost Context. Compare the water reuse alternative costs to other options facing the City and Participating Agencies.

How were costs calculated, and was cost sharing discussed?

The financial evaluation process included the following steps:

Unit Costs. Unit costs were developed from over 50 sources of information, including 23 bid summaries, two agency estimating tools, 14 project cost estimates, actual operating costs, and insight and experience from three national consulting firms.

Alternative Costs. Capital costs and operational and maintenance (O&M) costs were compiled in an interactive model. Costs were thoroughly developed and reviewed in five interactive workshops and a series of Status Update Meetings with the Project Stakeholders.

Financial Model Costs. Capital and O&M costs for each alternative were entered into a net present value (NPV) financial model that included financing costs and other variables. The financial model assumptions were closely coordinated with the City's financial staff to match typical City financing assumptions. The model was also vetted with the project stakeholder group (including the Participating Agencies' independent financial model expert).

Cost Framework. A cost framework for sharing project costs between the City and Participating Agencies was outlined in the Study. Multiple options were outlined based on an interactive workshop with project stakeholders.

How are costs presented in the Study?

Costs are presented in dollars per acre foot (\$/AF). The costs are broken down into Gross Costs and Net Costs as defined below. Net Costs are broken out further into three tiers or thresholds to provide a breakout for different conditions and to display values at each calculation step. The following summarizes the cost methodology. The resulting Alternative Costs are presented later in this Executive Summary.

What are Gross Costs?

Gross Costs include the capital and O&M costs for completing and operating the recycled water projects. The Gross Cost financial evaluation included a sensitivity analysis using the following three variables: project contingencies (ranging from 20 to 40 percent), Grants (ranging from 10 to 30 percent), and Metropolitan Water District/San Diego County Water Authority Local Resource Program (LRP) credits (ranging from \$100/AF to \$450/AF). The Favorable Scenario assumed the best case (20 percent contingency, 30 percent grants, \$450/AF LRP). The Unfavorable Scenario assumed the worst case (40 percent contingency, 10 percent grants, \$100/AF LRP). This sensitivity analysis was performed since stakeholder opinions varied on what the proper assumption should be. For the Study, the Stakeholder group agreed to use an average of these values.

Gross Cost Variables				
Item	Description	Favorable Scenario	Unfavorable Scenario	Average
Grants	To help offset the costs associated with projects, the City can apply for grants to help finance a portion of the capital projects.	30%	10%	20%
Local Resource Program	To help offset the costs associated with new water projects, the City has participated in the Local Resource Program offered by MWD and the Local Water Supply Development funding provided by the SDCWA (these two programs are collectively referred to herein as the LRP).	\$450/acre-foot, 20 years	\$100/acre-foot, 20 years	\$275/acre-foot, 20 years
Project Contingency	A project contingency was added to the construction costs of all alternatives to account for unanticipated project costs.	20%	40%	30%





What are Net Costs?

Net Costs are considered “real” or “true” costs for the purposes of comparing reuse projects to imported untreated water and other alternative water sources. Net Costs account for savings, offsets and credits that occur as a result of the reuse projects. For example, constructing a new reuse plant upstream of the Point Loma Plant reduces flows to the Point Loma Plant, resulting in lower capital and operational costs at the Point Loma Plant. These reduced costs are subtracted from the Gross Costs to get the Net Costs or “true” program cost. This is similar to the Orange County Groundwater Replenishment System, which was responsible for substantial savings by avoiding costly outfall improvements. The variables considered with the Net Cost calculations are described in the table on the next page. The Study also includes a Cost Methodology Summary in Appendix H. The Cost Methodology Summary is presented in an informative, frequently asked question (FAQ) format. This document summarizes direct and indirect wastewater savings calculations and includes a graphical comparison of the key wastewater facilities included in this Study with the facilities included in the City’s September 2011 Draft Wastewater Master Plan.

Net Cost Variables		
Component	Description	Savings
<p>Tier 1 - Direct Wastewater System Savings</p> <ul style="list-style-type: none"> Reduction of flows to downstream facilities Remaining Point Loma capacity is upgraded to Secondary 	<p>The Study's Alternatives achieve the goal of offloading flows away from the Point Loma Plant, resulting in reduced capital and operating costs at downstream wastewater facilities. The direct wastewater system savings were calculated by comparing the size of the Point Loma Plant proposed in the City's September 2011 Draft Wastewater Master Plan (adjusted to a secondary treatment option to the smaller Point Loma Plant size (which includes secondary treatment) in this Study (assuming the reuse projects in this Recycled Water Study are implemented). The cost difference is the savings directly attributable to these reuse projects. Key savings include:</p> <ul style="list-style-type: none"> Smaller Point Loma Plant facilities (less flow is treated at the Point Loma Plant) Smaller wet weather equalization basin (less flow reaches the Point Loma Plant) Less pumping at Pump Station No. 2 (less flow is diverted to the Point Loma Plant) Less pumping at Pump Station No. 1 (more reuse occurs at the South Bay Plant since more flow is diverted away from Pump Station No. 1) 	<p>\$557 million (capital savings)</p> <p>\$27.6 million/year (operation and maintenance savings)</p>
<p>Tier 2 - Salt Reduction Credit</p> <ul style="list-style-type: none"> Water quality improvements to water & wastewater systems due to indirect potable reuse Homeowner and business benefits not included in total 	<p>Similar to the 2005 Water Reuse Study, a salt credit was considered to account for the benefits of salinity reduction in the watershed. The salt credit basis is from the 1999 Salinity Management Study (MWD, USBR). The quantitative credit shown is the financial benefits of extending the life of the municipal water and wastewater treatment systems from having lower salinity levels in the water and wastewater flows. The San Vicente and Otay Lakes Reservoirs could see dramatic reductions in salinity levels from the proposed indirect potable reuse projects. Downstream agency facilities, including drinking water treatment plants and the Harbor Drive advanced water purification facilities, would benefit from this reduced salinity. In addition to the benefit shown, there is a benefit to water customers, since water heaters, clothes washers, dishwashers, and fixtures will also last longer with lower salinity levels. The combined savings included in the City's 2005 Water Reuse Study was \$250/AF. The \$100/AF value used in this Study only accounts for the estimated municipal treatment equipment savings.</p>	<p>\$100/acre foot (not including customer savings)</p>
<p>Tier 3 - Indirect Wastewater System Savings</p> <ul style="list-style-type: none"> Remaining Point Loma capacity maintained at CEPT Quantifies savings if this approach is attributable to the reuse program 	<p>The Point Loma Plant will either continue to use chemically enhanced primary treatment (CEPT) or will require upgrades to secondary treatment. This Study does not provide an opinion on whether CEPT or secondary treatment processes should be employed at the Point Loma Plant. However, it is prudent to summarize the reduced Point Loma Plant-related capital and operational costs if CEPT status could be maintained for the remaining Point Loma Plant capacity after reuse projects and with the South Bay Diversion. The indirect wastewater savings are therefore calculated as the avoided secondary treatment costs at the Point Loma Plant.</p>	<p>\$463 million (capital savings)</p> <p>\$13.0 million/year (operation and maintenance savings).</p>
<p>Qualitative Water System Savings</p>	<p>The local, regional and statewide water systems were considered for potential savings from increasing water reuse. Since quantitative costs could not be developed with current available information, qualitative benefits were considered, particularly at the regional and statewide level. The region's local water treatment plants treat water from local runoff (which is limited) and imported untreated water from the SDCWA and MWD (which is subject to cutbacks and higher price fluctuations). Indirect potable reuse projects provide a reliable, uninterrupted untreated water equivalent that would help supply the local water treatment plants that ratepayers have invested in over the past decade. Indirect potable reuse projects may defer or eliminate the need to expand the imported untreated water conveyance system needed to serve these treatment plants. The SDCWA Master Plan (currently underway) may help quantify what these benefits are in future updates to this Study. In addition, Stakeholders emphasized an additional benefit related to the need to fix water supply conditions in the California Bay-Delta (which has the potential for substantial cost impacts for Southern California). Water reuse projects reduce the burden on importing water from the Bay-Delta, providing an additional benefit for these projects.</p>	<p>Quantitative benefits are speculative, therefore this category is currently considered qualitatively</p>

What is the Existing Recycled Water System?

The City operates two water reclamation plants as part of the Metro System: the North City Plant and the South Bay Plant. Two additional reclamation plants (each separately owned and operated by a Participating Agency and separate from the Metro System) also offload flows before reaching the Metro System. The City also operates a non-potable recycled water system comprised of two service areas—the Northern Service Area and the Southern Service Area—supplied with recycled water from the North City and South Bay Plants, respectively. Three wholesale purchasers of recycled water for the City are located within the service area: City of Poway and Olivenhain Municipal Water District (Northern Service Area) and Otay Water District (Southern Service Area).

Recycled Water System in the San Diego Service Area			
Treatment Plant	Year Commissioned	Design Capacity	Description
<p>North City Water Reclamation Plant</p> 	1997	30 mgd	Part of City of San Diego’s Metro System. Treats wastewater generated in the Northern San Diego Region, including Cities of Del Mar and Poway, and the communities of Mira Mesa, Rancho Penasquitos, Scripps Ranch, and Rancho Bernardo. Tertiary-treated water is distributed to surrounding communities for irrigation and industrial uses. Excess wastewater ultimately flows to the Point Loma Plant.
<p>South Bay Water Reclamation Plant</p> 	2002	15 mgd	Part of City of San Diego’s Metro System. Located in the Tijuana River Valley near the international border. Tertiary-treated wastewater is distributed to surrounding areas for non-potable recycled water use.
<p>Padre Dam Water Recycling Facility</p> 	1967	2.0 mgd	Owned and operated by Padre Dam Municipal Water District and treats wastewater from the City of Santee, portions of the City of El Cajon, and the unincorporated community of Lakeside. Treated wastewater that is not recycled for irrigation and industrial use is discharged to the Santee Lakes and ultimately reaches the San Diego River. Padre Dam, in conjunction with Helix Water District, is evaluating the ability to expand the plant as part of indirect potable reuse project in the El Monte Valley.
<p>Ralph W. Chapman Water Recycling Facility</p> 	1988	1.1 mgd	Owned and operated by Otay Water District. Recycled water is used for irrigation in Eastlake, Otay Ranch, Rancho Del Rey, and other areas of Chula Vista.

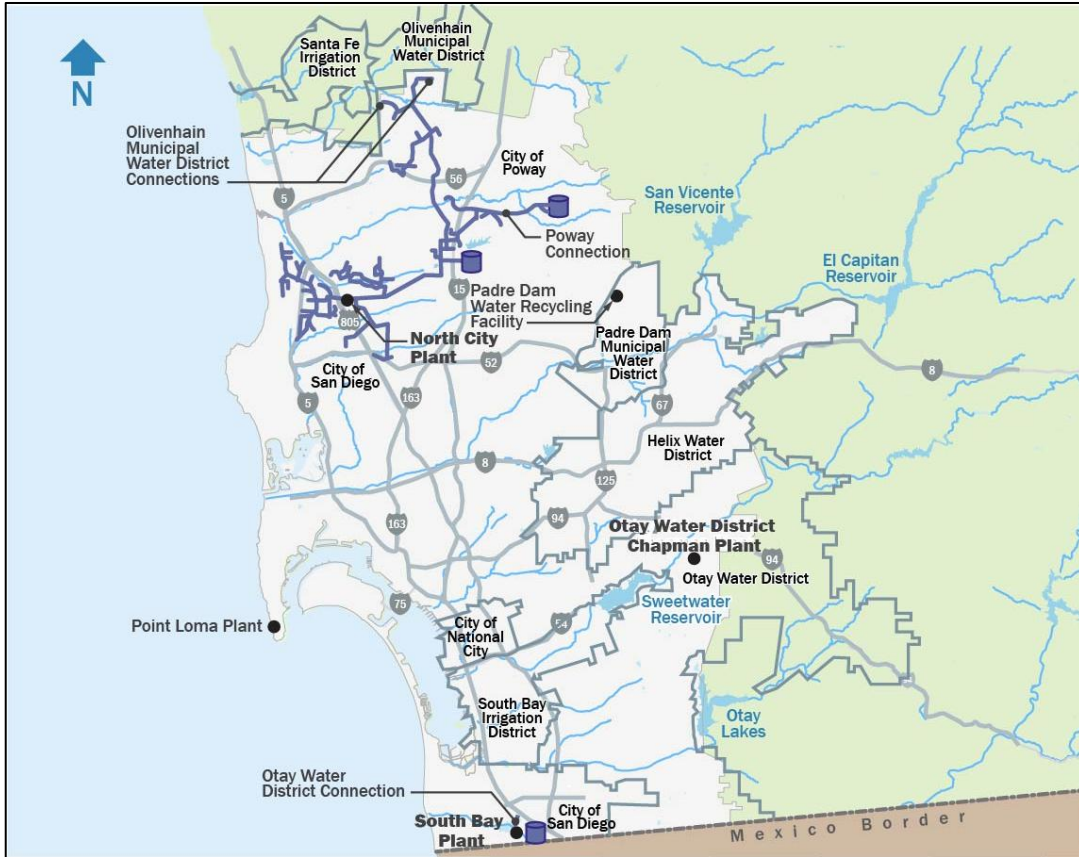

Existing Recycled Water Facilities

What Projects Will Affect Future Reuse in San Diego?

The City’s 2005 Water Reuse Study recommended an indirect potable reuse project at the North City Plant that would deliver water to the San Vicente Reservoir. To begin implementing this project, the City completed construction of the Advanced Water Treatment Facility, a component of the Water Purification Demonstration Project, in 2011 at the North City Plant. This project, and the corresponding modeling study of the San Vicente Reservoir, will provide data on the health, safety, and water quality of advanced treated recycled water. A separate project, the San Vicente Dam Raise, is currently underway and will increase the potential for integrated indirect potable reuse projects at this regional facility.



Water Purification Demonstration Project. The City’s Water Purification Demonstration Project will demonstrate how one million gallons per day can be purified using technology that is able to produce one of the most pristine sources of water available anywhere.



San Vicente Dam Raise. The San Vicente Reservoir expansion (architectural rendering shown above) and its integration with regional facilities make this reservoir an ideal candidate for indirect potable reuse.

What Opportunities Were Considered for the Reuse Solutions?

Non-Potable Recycled Water Opportunities



Since the City has a non-potable system in place, focus was placed on expanding this system by locating new demands. The demands would then be met by expanding the distribution system from an existing plant or by constructing a new treatment facility closer to the demand. Both Citywide (increasing use within the City’s service area) and wholesale (increasing supply to agencies adjacent to or already connected to the existing system) were considered through a market assessment. The market assessment showed where potential conversion customers were concentrated (for example, the Rancho Bernardo area). Based on the markets, distribution systems were developed to determine costs. An analysis of the results, including a direct comparison of an alternative both with and without service to the Rancho Bernardo area, showed that the construction costs to dual pipe an existing community and the administrative costs required to permit, coordinate, bill and provide backflow testing were higher than the indirect potable reuse approaches for new areas. Therefore, the non-potable recycled water opportunities carried forward were focused on maximizing the existing system where most economical. The non-potable recycled water demands carried forward can be summarized as the existing demands, planned demands, and future demands (which includes 3 mgd for expanded service from the South Bay Plant occurring between 2026 and 2040).

Indirect Potable Reuse Opportunities

Achieving a water reuse target with the potential to use all the Metro System service area resources reinforced the need to look for larger projects with improved economy of scale. Indirect potable reuse projects provided the needed scope and scale for this purpose. Two types of indirect potable reuse were considered: reservoir augmentation and groundwater recharge. Eleven regional reservoirs were initially considered. Three were advanced for more detailed evaluation: San Vicente Reservoir (with the current dam raise project), Otay Lakes, and Lake Hodges. Eight regional groundwater basins were reviewed, and two were carried forward for more detailed evaluation: El Monte Valley Basin and San Pasqual Basin. Advancing reservoirs/basins was based on the location, costs, potential project sizes, and ability to integrate into the water system.

Benefits of Indirect Potable Reuse

- Maximizes use of existing reclamation capacity
- Reduced capital and operating costs in downstream wastewater systems, particularly the Point Loma Plant
- Less seasonally limited than non-potable recycled water with fixed irrigation demands
- Superior ability to improve water quality by significantly reducing total dissolved solids/salinity

Successful Southern California Indirect Potable Reuse Projects



Orange County Water District’s Groundwater Replenishment System. The Groundwater Replenishment System is the world’s largest wastewater purification system for indirect potable reuse and it is located just north of San Diego in Orange County, California. The Orange County Groundwater Replenishment System can produce up to 70 mgd of highly purified recycled water that serves the water demands of nearly 600,000 residents.



Montebello Forebay. Located in Los Angeles County, the Montebello Forebay has been recharged dating back to 1960s. The area is currently recharged with 150,000 acre-feet of local, imported, and recycled water annually. Of the 5.6 million acre feet recharged into the basin since the 1960s, 26 percent was from recycled water sources.



West Coast, Dominguez Gap, and Alamitos Barriers. Los Angeles and Orange Counties also use seawater intrusion barriers to protect and supplement groundwater supplies. Recycled water is injected into wells along these basins to prevent high salinity seawater from reaching the groundwater basin supplies. The injected recycled water also supplements the groundwater that is extracted by wells and serves the drinking water system.



How Were Opportunities Compiled into Area Concepts?

Area Concepts were developed to provide detailed, comparable options for discussion at the Coarse Screening Session and Stakeholder Status Update Meetings, and were then refined and compiled into Integrated Reuse Alternatives. The Area Concepts were strategically selected, based on the locations of available wastewater, existing facilities, and delivery points (non-potable recycled water customers, surface water reservoirs, or groundwater basins).

Opportunities were sized and then pieced together by laying out treatment and conveyance facilities. Cost information was also developed, with pumping costs being a particularly important component because of the variability of pumping costs for indirect potable reuse, non-potable water, and wastewater. The availability of this information allowed Stakeholders to compare the benefits of different approaches within each area. For example, Alternatives that required extensive wastewater pumping (which requires pumping approximately 30-percent more flow than advanced treated water), were identified as having added costs and risks compared to other Alternatives. This point led to development of the Harbor Drive Plant concept later in the Study.



Area Concepts. Area Concepts were developed for three regions of the Metro Service Area. The Area Concepts were presented at the Coarse Screening Session.

Area Concept Summary		
Area	Base Concept Presented at the Coarse Screening Session	Additional Considerations after Stakeholder Review
San Vicente/ North City	<ul style="list-style-type: none"> Complete planned non-potable recycled water projects Maximize indirect reuse of water produced at North City Plant with diversions from <ul style="list-style-type: none"> Morena Mission Valley Treat and produce water at Mission Gorge Account for El Monte Valley indirect potable reuse project 	<ul style="list-style-type: none"> Reduce pumping of wastewater by eliminating diversion of wastewater at Mission Valley Treat and produce water at Harbor Drive site Consider both split plant and consolidated plant at Harbor Drive and Mission Valley to minimize site needs Consider additional costs and complexities related to expanded North City Plant beyond master-planned capacity of 45 mgd
South Bay	<ul style="list-style-type: none"> Complete planned non-potable recycled water projects Wastewater diversions from different locations along the South Metro Interceptor (depending on the option) Consider serving additional non-potable recycled water demands Indirect potable reuse of water produced at South Bay Plant 	<ul style="list-style-type: none"> Consider increased diversion totals by locating the diversion further North at the Spring Valley No. 8 connection
Rancho Bernardo/ San Pasqual	<ul style="list-style-type: none"> Rancho Bernardo/I-15 Corridor, non-potable recycled water San Pasqual indirect potable reuse (two variations) 	<ul style="list-style-type: none"> Determined that these options do not offload the Point Loma Plant and provide limited benefits to other opportunities Consider private entities funding a majority of the improvements needed



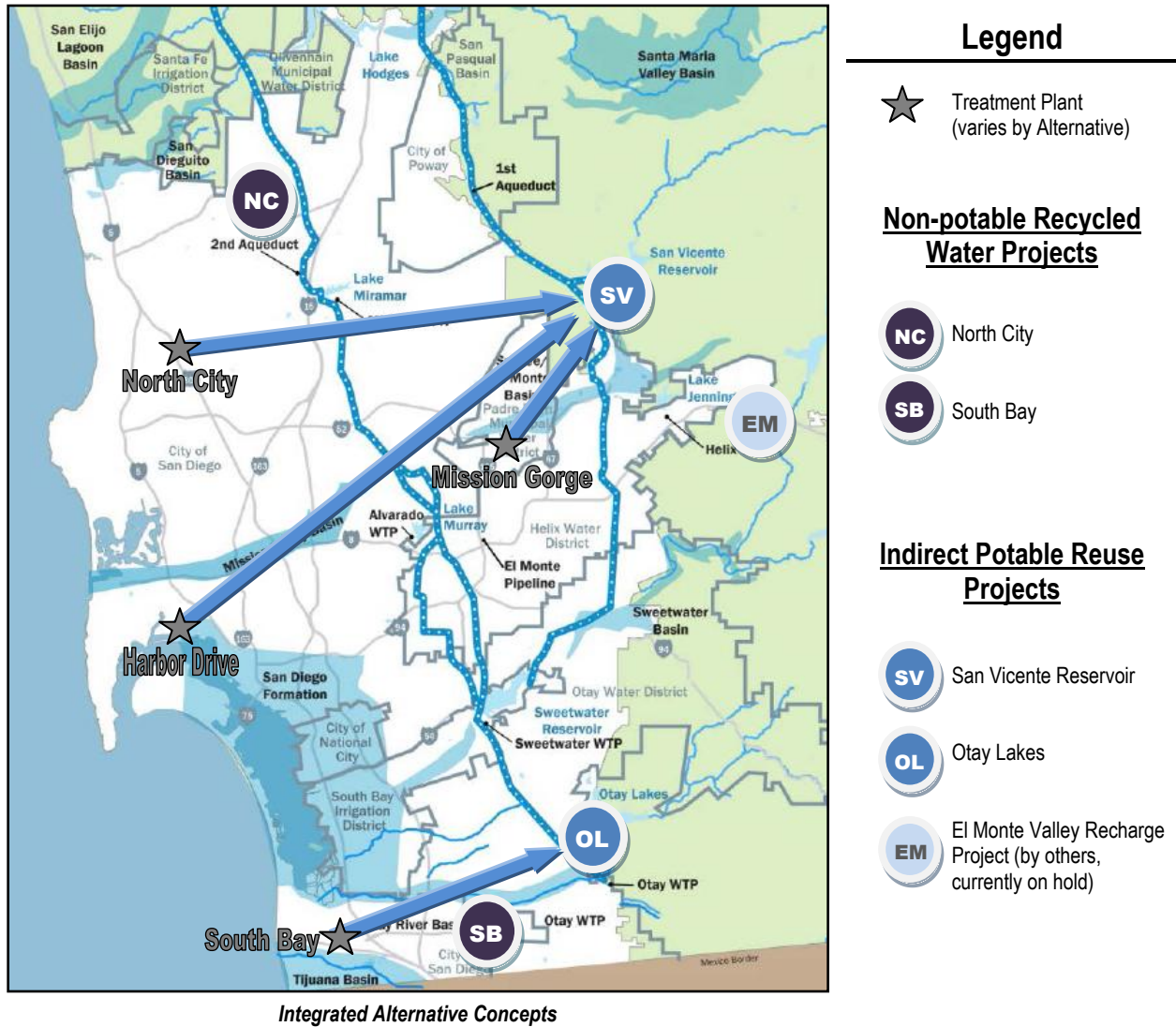

How Were Area Concepts Refined into Integrated Reuse Alternatives?

Area Concepts were refined into Integrated Reuse Alternatives in the Fine Screening Session. Fine Screening Session participants considered a series of projects to meet the 100 mgd water reuse target. The non-potable recycled water demands and the indirect potable reuse project delivery locations that advanced to the Fine Screening Session are summarized in the two adjacent tables and are shown on the figure below.









Non-potable Recycled Water. Expansion of the non-potable recycled water systems is planned primarily through 2015, with additional growth in South Bay through 2040 based on Otay Water District’s projections, as shown below.

Non-Potable Recycled Water Projected Demands											
Map Code	Agency	Existing 2009/2010		Planned 2010-2015		Planned (OWD) 2015-2026		Future (OWD) 2026-2040		Total	
		AFY	mgd	AFY	mgd	AFY	mgd	AFY	mgd	AFY	mgd
North City Plant											
	City of San Diego	6,394	5.7	1,959	1.7	0	0.0	0	0.0	8,353	7.4
	City of Poway	428	0.4	323	0.3	0	0.0	0	0.0	751	0.7
	Olivenhain MWD	642	0.6	458	0.4	0	0.0	0	0.0	1,100	1.0
	Total North City	7,464	6.7	2,740	2.4	0	0.0	0	0.0	10,204	9.1
South Bay Plant											
	City of San Diego	1,539	1.4	-639	-0.6	0	0.0	0	0.0	900	0.8
	Otay Water District	3,209	2.9	1,395	1.2	1243	1.1	3,363	3.0	9,210	8.3
	Total South Bay	4,748	4.2	756	0.7	1,243	1.1	3,363	3.0	10,110	9.0
North City and South Bay Plants											
	Total Combined	12,212	10.9	3,496	3.1	1,243	1.1	3,363	3.0	20,314	18.1

Notes: See Study Table 5-3 for notes. Demands shown are average annual demands. Reductions in demands for South Bay between 2010 and 2015 are associated with changes at the International Boundary and Water Commission Plant, which will no longer require non-potable recycled water for process uses.

Indirect Potable Reuse. Two surface water augmentation projects and a groundwater recharge project were advanced into the Fine Screening Session. In addition, the El Monte Valley Groundwater Augmentation Project (being planned by others) was assumed to occur and its impacts were taken into consideration.

Indirect Potable Reuse Projects Advanced					
Map Code	Reservoir or Basin	Storage Capacity (acre-feet)	Reuse Potential		Key Considerations
			AFY	mgd	
Surface Water Reservoir Candidates Advanced to the Fine Screening Session					
	San Vicente (w/ Dam Raise) 	249,358	Up to 100,000	Up to 89	Recommended approach from 2005 Water Reuse Study. The dam raise, scheduled for completion between 2013 and 2014, will increase retention times and indirect potable reuse capacity potential, and provides the ability to distribute water throughout the region and to the largest water treatment plants.
	Otay Lakes 	49,849	Up to 25,000	Up to 22	Previous recommendation from 2005 Water Reuse Study, with proximity to South Bay Plant. Located adjacent to the 33 mgd (2035 capacity) Otay Water Treatment Plant.
Groundwater Augmentation Project by Others Considered					
	El Monte Valley (or similar project) 	10,000 to 50,000	5,000	4.5 to 5.0	The El Monte basin was evaluated by the Helix Water District and the Padre Dam Municipal Water District for an indirect potable reuse groundwater augmentation project. This project was coordinated with this Study since wastewater flows for this project affect downstream wastewater availability in the Metro System. Although this project is currently on hold, it or a similar project could further offload the wastewater system and provide valuable new water to the region. The status of this project is anticipated to be tracked as an Implementation Step.

Notes: See Study Tables 6-1 and 6-3 for notes. Demands shown are average annual demands.



What was the Rationale for Numbering the Integrated Reuse Alternatives?

The following summarizes the numbering system used. Each Alternative includes common South Bay components

Alternatives:

“A” Alternatives. The “A” Alternatives expand the North City Plant to 45 mgd (the site’s master-planned capacity) using the Morena Diversion. The added capacity at North City allows the Harbor Drive Plant to be smaller than the “B” Alternatives.

“B” Alternatives. The “B” Alternatives maximize the existing North City Plant capacity at 30 mgd (which occurs once the initial 15 mgd indirect potable reuse project is complete). The smaller total at the North City Plant requires the Harbor Drive Plant to be larger than the “A” Alternatives.

Sub-Alternatives:

“1” Sub-Alternatives. Alternatives “A1” and “B1” differ from the “2” (A2, B2) and “3” (B3) alternatives by splitting the Harbor Drive water reclamation treatment processes and the advanced purification facility treatment into different sites (the advanced purification processes are located at the Camino Del Rio site described in Chapter 7). This adds a fourth plant site to these alternatives.

“2” Sub-Alternative. Alternatives “A2” and “B2” also relate to the Harbor Drive Plant. The “2” Alternatives place all the Harbor Drive water reclamation and advanced purification treatment processes at a combined plant along Harbor Drive (similar to how the proposed North City and South Bay Plants will be configured). The Harbor Drive Plant in these alternatives is larger, but the operation is efficiently consolidated to a single site.

“3” Sub-Alternative. Alternative “B3” is the same as Alternative “B2”, except that it includes a small plant in Mission Gorge to collect, treat, and convey water to the San Vicente Reservoir. This adds a fourth plant, but it is the closest location to the San Vicente Reservoir.

Major Alternatives

“A” Alternatives =
North City at 45 mgd + South Bay
with SV8 diversion

“B” Alternatives =
North City at 30 mgd + South Bay
with SV8 diversion

Sub-alternatives Based on Siting Elements

“1” Alternatives
split plant between Harbor Drive
& Camino del Rio

“2” Alternatives
combined Harbor
Drive Plant

“3” Alternative
combined Harbor Drive plant
and an additional plant at
Mission Gorge

Summary of Integrated Reuse Alternative Elements

Integrated Reuse Alternatives were formed based on the project goals established by the project Stakeholders, the criteria developed at the Framework Planning Session, and the screening work performed at the Coarse Screening and Fine Screening Sessions, and subsequent Stakeholder Status Update Meetings. The following table summarizes the elements included in each Integrated Reuse Alternative.

Integrated Reuse Alternative Summary - Elements Included					
Elements in the Area Concept	A1	A2	B1	B2	B3
Elements from the North City/San Vicente Area Concept Themes					
Existing non-potable recycled water demands (6.7 mgd)	✓	✓	✓	✓	✓
Planned non-potable recycled water demands (2.4 mgd)	✓	✓	✓	✓	✓
North City Plant w/indirect potable reuse to San Vicente (15.0 mgd)	✓	✓	✓	✓	✓
Morena Diversion w/North City Plant expansion & indirect potable reuse to San Vicente (11.9 mgd)	✓	✓			
Harbor Drive Plant w/indirect potable reuse to San Vicente (capacity varies depending on the Alternative: 40.9 mgd for A1/A2; 52.8 mgd for B1/B2; and 46.0 mgd for B3)	✓	✓	✓	✓	✓
Harbor Drive consolidated WRP/AWPF plant		✓		✓	✓
Harbor Drive WRP/Camino Del Rio AWPF split plant	✓		✓		
Mission Gorge Plant w/indirect potable reuse to San Vicente (6.8 mgd)					✓
Elements from South Bay Area Concept C2					
Existing non-potable recycled water demands (4.2 mgd)	✓	✓	✓	✓	✓
Planned non-potable recycled water demands (1.8 mgd)	✓	✓	✓	✓	✓
Additional future non-potable recycled water demands (3.0 mgd)	✓	✓	✓	✓	✓
Spring Valley No. 8 Diversion to South Bay (31.1 mgd)	✓	✓	✓	✓	✓
South Bay indirect potable reuse to Otay Lakes (15.0 mgd)	✓	✓	✓	✓	✓

Note: Flows for non-potable recycled water and indirect potable reuse projects are average annual totals based on the output of the plant. Flows for the Spring Valley diversion are based on 2035 Dry Weather Flows. WRP = Water Reclamation Plant; AWPF = Advanced Water Purification Facility

Summary of Financial Terms Used

A full description of financial terminology was included previously in this Executive Summary. The following table provides a summary to aid reviewing the Alternative Summary pages that follow.

Cost Level	Description
Gross Costs	Gross costs include the capital and O&M costs for completing and operating the recycled water projects. It does not account for reduced capital and O&M expenses at downstream facilities or other benefits/credits.
Tier 1 Net Costs Direct Wastewater System Savings	With the proposed reuse program, flows to downstream facilities are less, resulting in lower capital and operating costs. Tier 1 shows the reuse cost with these adjustments. (Point Loma Plant, Pump Station 1, Pump Station 2).
Tier 2 Net Costs Salt Reduction Credit	The IPR projects substantially reduce salinity/TDS which lowers operating costs in the downstream water and wastewater systems (there is also a customer benefit treated qualitatively).
Tier 3 Net Costs Indirect Wastewater Savings (CEPT)	The reuse program will reduce mass emissions at Point Loma. This cost tier summarizes the net costs if the reuse program contributes to maintaining chemically enhanced primary treatment at Point Loma.



Summary of Integrated Reuse Alternatives A1 and A2

Facility Map

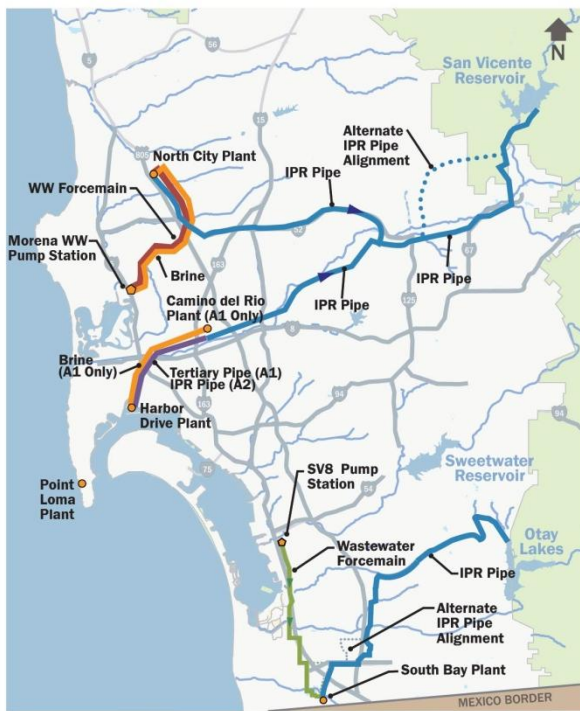

Reuse By Phase

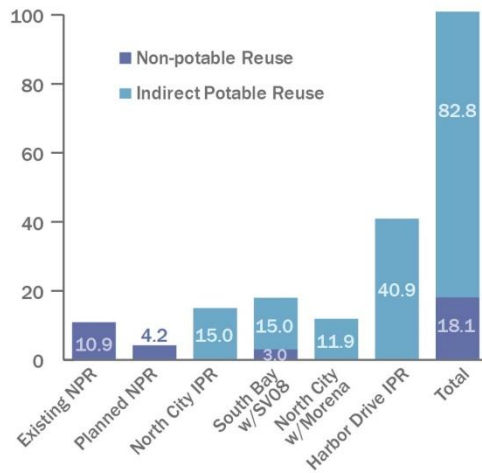

Reuse Per Plant



A1/A2 Allocation of Metro System Flows (2035 Dry Weather Conditions)

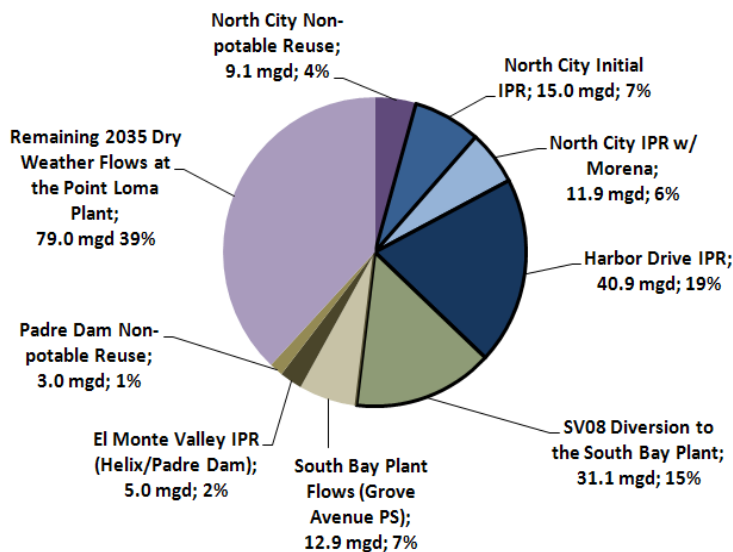

Figure 8-2 Integrated Reuse Alternatives A1 and A2

(upper left) – Displays the facilities included in Alternatives A1 and A2. A1 differs only in that the advanced treatment processes at the Harbor Drive Plant are located at the Camino del Rio site.

(Above) – The charts above includes reuse totals per project and per plant for both non-potable recycled water and indirect potable reuse.

(Left) – The pie chart to the left displays the allocation of Metro System flows estimated for the 2035 dry weather year flow scenario. The black bordered portions represent 99 mgd of offload provided by the facilities included in this Study. Wet weather allocations are presented in Appendix B.

Summary of Integrated Reuse Alternatives A1 and A2 (Continued)

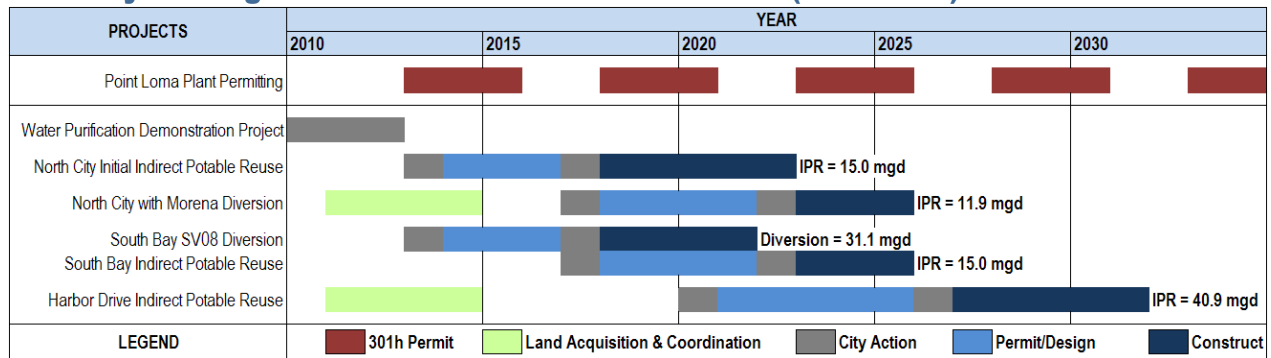

Alternative A1/A2 Implementation Schedule

Note: The planned 21 mgd expansion of South Bay as part of the September 2011 Draft Wastewater Master Plan may allow deferring or eliminating the 26 mgd primary and secondary expansion included in this Study. South Bay plant sizing and capacities shall be coordinated with wastewater planning efforts and Point Loma permit discussions per the implementation steps.

Alternative A1/A2 New Water and Point Loma Offloading (Totals in mgd)								
Start of Operations	New Water (mgd)					Wastewater Offload (mgd)		
	North City	Harbor Drive	Mission Gorge	South Bay	Cumulative	Reuse (N/I South Bay)	Diverted to South Bay	Cumulative
2023	15.0	0.0	-	0.0	15.0	15.0	0.0	15.0
2022	0	0.0	-	0.0	15.0	0.0	31.1	46.1
2026	11.9	0.0	-	0.0	26.9	11.9	0.0	58.0
2026	0.0	0.0	-	18.0	44.9	0.0	0.0	58.0
2032	0.0	40.9	-	0.0	85.8	40.9	0.0	98.9

Note: New water and wastewater offloading totals are based on the reuse projects included in the cost estimates for this Study. The totals do not include the proposed El Monte Groundwater Recharge IPR Project (5 mgd); existing and planned non-potable reuse for the North City Plant (9.1 mgd) and Padre Dam Plant (3.0 mgd); and the Grove Ave. Pump Station (12.9 mgd - which accounts for South Bay non-potable reuse thru 2026). South Bay new water totals include: 15 mgd for IPR and 3 mgd for non-potable reuse (Otay Water District, 2026 to 2040). Point Loma offload totals are based on 2035 Dry Weather Flows. Point Loma offloading due to South Bay is accounted for based on the diversion flows, not the new water created.

Alternative A1/A2 Capital and Annual O&M Costs							
Item		2014 North City initial	2014 South Bay Diversion	2018 Morena	2018 South Bay IPR	2021 Harbor Drive (Alternative A1)	2021 Harbor Drive (Alternative A2)
Incremental Costs	Capital	\$410,700,000	\$20,700,000	\$301,300,000	\$455,400,000	\$1,000,000,000	\$1,012,200,000
	O&M	\$17,600,000	\$300,000	\$13,100,000	\$22,700,000	\$51,000,000	\$50,800,000
Cumulative Costs	Capital	\$410,700,000	\$431,400,000	\$732,800,000	\$1,188,200,000	\$2,188,200,000	\$2,200,400,000
	O&M	\$17,600,000	\$17,900,000	\$31,000,000	\$53,600,000	\$104,700,000	\$104,500,000

Note: Capital & O&M Costs shown above are from the Favorable financial model scenario, and include a 20-percent project contingency.

Alternative A1/A2 Reuse Water Cost Summary (2011 \$/AF)		
Cost Category	Alternative A1	Alternative A2
Gross Costs (Before Avoided Facilities and Other Offset Savings)	\$1,900	\$1,900
Tier 1 Net Costs (With Direct Wastewater System Savings)	\$1,300	\$1,300
Tier 2 Net Costs (With Salt Credit Plus Tier 1 Savings)	\$1,200	\$1,200
Tier 3 Net Costs (With Indirect Wastewater System Savings Plus Tier 1 and Tier 2 Savings)	\$800	\$800
2011 Untreated Imported Water Costs (for comparison purposes)	\$904	\$904

Note: The reuse water cost summary above represents average costs based on the Favorable and Unfavorable financial model scenarios. See Section 8.4 for more details on the financial evaluation and cost descriptions. Tier 1 savings includes wastewater projects no longer necessary due to the reuse projects and offloading included in this Study. Tier 2 savings accounts for savings due to water quality improvements. Tier 3 conceptualizes the savings that could occur if maintaining chemically enhanced primary treatment at the Point Loma Plant was made possible due to the reuse program proposed in this Study. Costs shown above are for comparison of untreated water options, and do not include potable water treatment plant costs.



Summary of Integrated Reuse Alternatives B1 and B2

Facility Map



Reuse By Phase

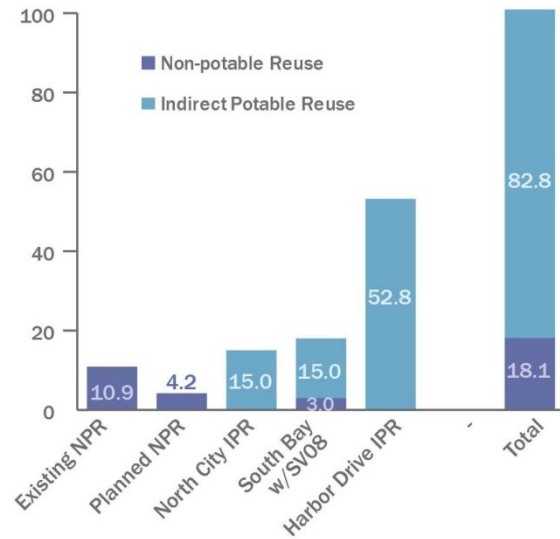

Reuse Per Plant

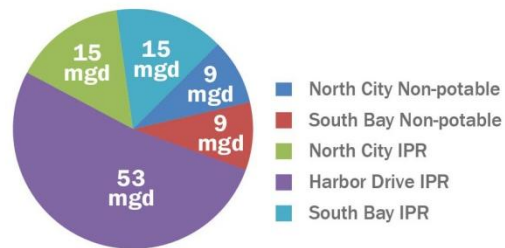

B1/B2 Allocation of Metro System Flow (2035 Dry Weather Conditions)

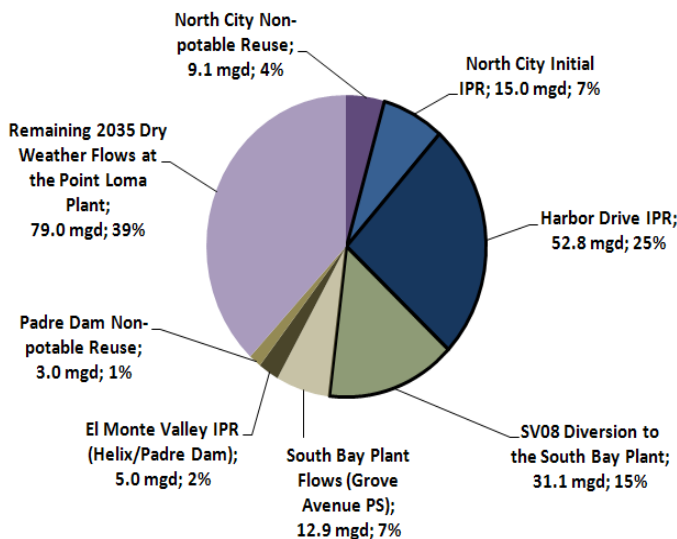

Figure 8-4. Integrated Reuse Alternatives B1 and B2

(upper left) – Displays the facilities included in Alternatives B1 and B2. B1 differs only in that the advanced treatment processes at the Harbor Drive Plant are located at the Camino del Rio site.

(Above) – The charts above includes reuse totals per project and per plant for both non-potable recycled water and indirect potable reuse.

(Left) – The pie chart to the left displays the allocation of Metro System flows estimated for the 2035 dry weather year flow scenario. The black bordered portions represent 99 mgd of offload provided by the facilities included in this Study. Wet weather allocations are presented in Appendix B.

Summary of Integrated Reuse Alternatives B1 and B2 (Continued)

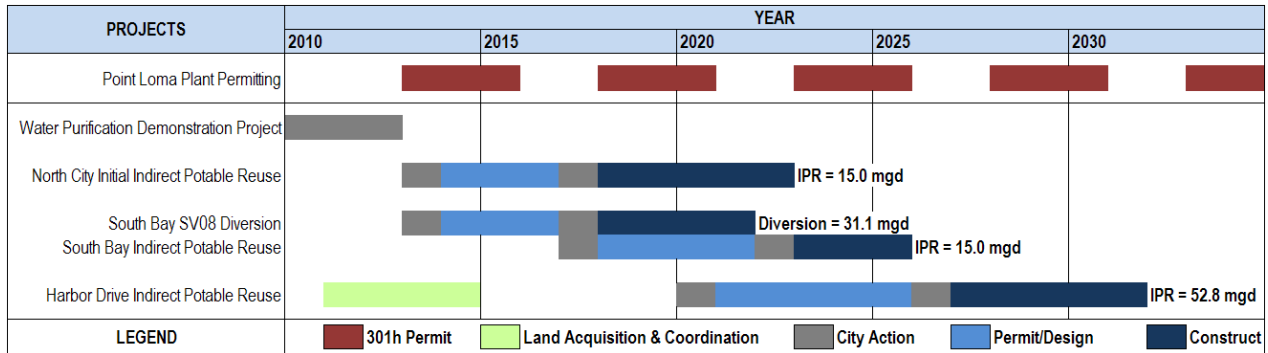

Alternative B1/B2 Implementation Schedule

Note: The planned 21 mgd expansion of South Bay as part of the September 2011 Draft Wastewater Master Plan may allow deferring or eliminating the 26 mgd primary and secondary expansion included in this Study. South Bay plant sizing and capacities shall be coordinated with wastewater planning efforts and Point Loma permit discussions per the implementation steps.

Alternative B1/B2 New Water and Point Loma Offloading (Totals in mgd)								
Start of Operations	New Water (mgd)					Wastewater Offload (mgd)		
	North City	Harbor Drive	Mission Gorge	South Bay	Cumulative	Reuse (N/I South Bay)	Diverted to South Bay	Cumulative
2023	15.0	0.0	-	0.0	15.0	15.0	0.0	15.0
2022	0.0	0.0	-	0.0	15.0	0.0	31.1	46.1
2026	0.0	0.0	-	18.0	33.0	0.0	0.0	46.1
2032	0.0	52.8	-	0.0	85.8	52.8	0.0	98.9

Notes: New water and wastewater offloading totals are based on the reuse projects included in the cost estimates for this Study. The totals do not include the proposed El Monte Groundwater Recharge IPR Project (5 mgd); existing and planned non-potable reuse for the North City Plant (9.1 mgd) and Padre Dam Plant (3.0 mgd); and the Grove Ave. Pump Station (12.9 mgd - which accounts for South Bay non-potable reuse thru 2026). South Bay new water totals include: 15 mgd for IPR and 3 mgd for non-potable reuse (Otay Water District, 2026 to 2040). Point Loma offload totals are based on 2035 Dry Weather Flows. Point Loma offloading due to South Bay is accounted for based on the diversion flows, not the new water created.

Alternative B1/B2 Capital and Annual O&M Costs						
Item		2014	2014	2018	2021	2021
		North City initial	South Bay Diversion	South Bay IPR & 3 mgd non-potable	Harbor Drive (Alternative B1)	Harbor Drive (Alternative B2)
Incremental Costs	Capital	\$340,700,000	\$20,700,000	\$455,400,000	\$1,159,900,000	\$1,168,300,000
	O&M	\$17,300,000	\$300,000	\$22,700,000	\$61,200,000	\$60,500,000
Cumulative Costs	Capital	\$340,700,000	\$361,400,000	\$816,800,000	\$1,976,700,000	\$1,985,100,000
	O&M	\$17,300,000	\$17,600,000	\$40,300,000	\$101,500,000	\$100,800,000

Note: Capital & O&M Costs shown above are from the Favorable financial model scenario, and include a 20-percent project contingency.

Alternative B1/B2 Unit Cost Summary (2011 \$/AF)		
Cost Category	Alternative B1	Alternative B2
Gross Costs (Before Avoided Facilities and Other Offset Savings)	\$1,700	\$1,700
Tier 1 Net Costs (With Direct Wastewater System Savings)	\$1,100	\$1,100
Tier 2 Net Costs (With Salt Credit Plus Tier 1 Savings)	\$1,000	\$1,000
Tier 3 Net Costs (With Indirect Wastewater System Savings Plus Tier 1 and Tier 2 Savings)	\$600	\$600
2011 Untreated Imported Water Costs (for comparison purposes)	\$904	\$904

Note: The reuse water cost summary above represents average costs based on the Favorable and Unfavorable financial model scenarios. See Section 8.4 for more details on the financial evaluation and cost descriptions. Tier 1 savings includes wastewater projects no longer necessary due to the reuse projects and offloading included in this Study. Tier 2 savings accounts for savings due to water quality improvements. Tier 3 conceptualizes the savings that could occur if maintaining chemically enhanced primary treatment at the Point Loma Plant was made possible due to the reuse program proposed in this Study. Costs shown above are for comparison of untreated water options, and do not include potable water treatment plant costs.



Summary of Integrated Reuse Alternative B3

Facility Map



Reuse by Phase

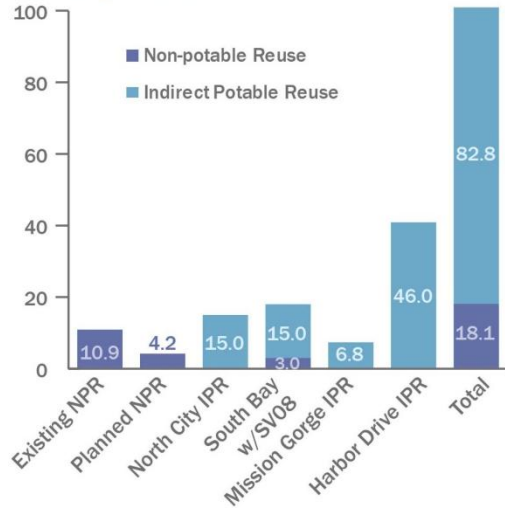

Reuse Per Plant

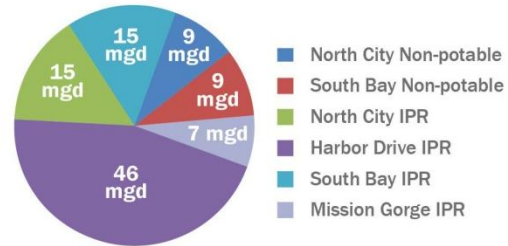

B3 Allocation of Metro System Flows (2035 Dry Weather Conditions)

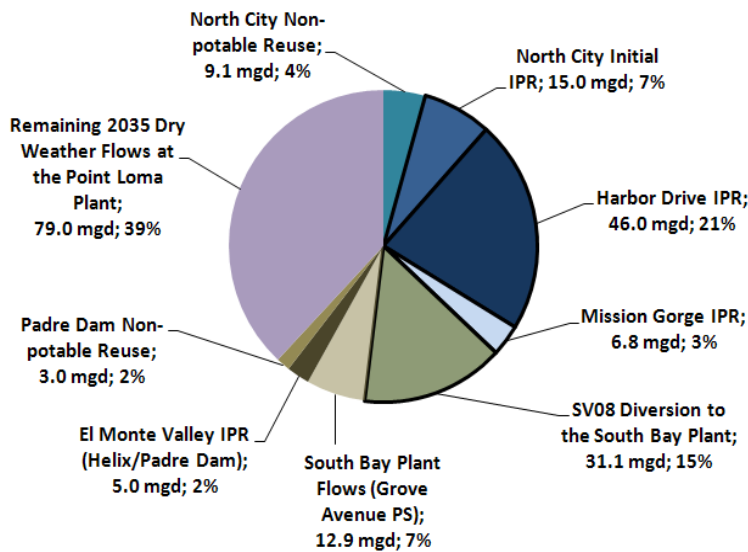

Figure 8-6. Integrated Reuse Alternative B3

(upper left) – Displays the facilities included in Alternative B3. The Mission Gorge Plant is the only difference between this Alternative and Alternative B2.

(Above) – The charts above includes reuse totals per project and per plant for both non-potable recycled water and indirect potable reuse.

(Left) – The pie chart to the left displays the allocation of Metro System flows estimated for the 2035 dry weather year flow scenario. The black bordered portions represent 99 mgd of offload provided by the facilities included in this Study. Wet weather allocations are presented in Appendix B.

Summary of Integrated Reuse Alternative B3 (Continued)

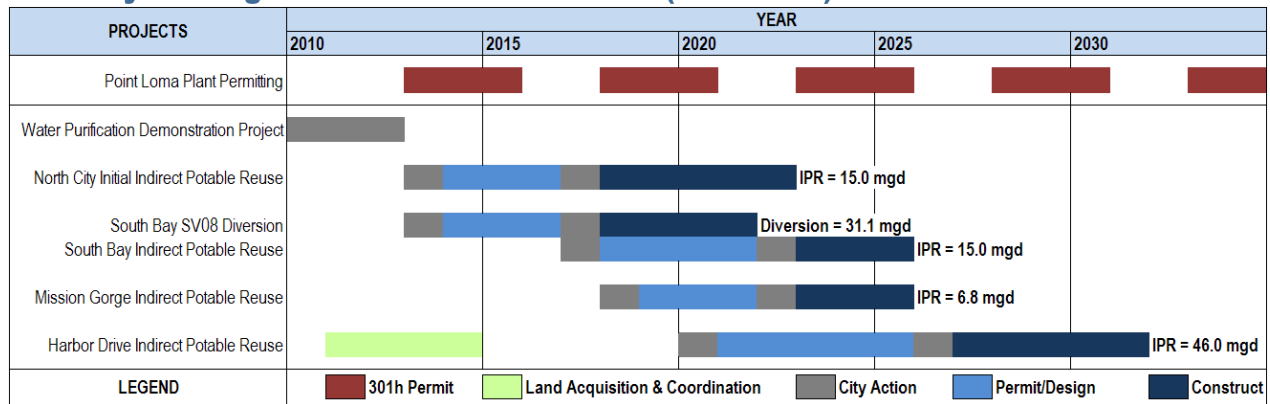

Alternative B3 Implementation Schedule

Note: The planned 21 mgd expansion of South Bay as part of the September 2011 Draft Wastewater Master Plan may allow deferring or eliminating the 26 mgd primary and secondary expansion included in this Study. South Bay plant sizing and capacities shall be coordinated with wastewater planning efforts and Point Loma permit discussions per the implementation steps.

Alternative B3 New Water and Point Loma Offloading (Totals in mgd)

Start of Operations	New Water (mgd)					Wastewater Offload (mgd)		
	North City	Harbor Drive	Mission Gorge	South Bay	Cumulative	Reuse (N/I South Bay)	Diverted to South Bay	Cumulative
2023	15.0	0.0	0.0	0.0	15.0	15.0	0.0	15.0
2022	0.0	0.0	0.0	0.0	15.0	0.0	31.1	46.1
2026	0.0	0.0	0.0	18.0	33.0	0.0	0.0	46.1
2026	0.0	0.0	6.8	0.0	39.8	6.8	0.0	52.9
2032	0.0	46.0	0.0	0.0	85.8	46.0	0.0	98.9

Note: New water and wastewater offloading totals are based on the reuse projects included in the cost estimates for this Study. The totals do not include the proposed El Monte Groundwater Recharge IPR Project (5 mgd); existing and planned non-potable reuse for the North City Plant (9.1 mgd) and Padre Dam Plant (3.0 mgd); and the Grove Ave. Pump Station (12.9 mgd - which accounts for South Bay non-potable reuse thru 2026). South Bay new water totals include: 15 mgd for IPR and 3 mgd for non-potable reuse (Otay Water District, 2026 to 2040). Point Loma offload totals are based on 2035 Dry Weather Flows. Point Loma offloading due to South Bay is accounted for based on the diversion flows, not the new water created.

Alternative B3 Capital and Annual O&M Costs

Item	2014	2014	2018	2019	2021	
	North City initial	South Bay Diversion	South Bay IPR & 3 mgd non-potable	Mission Gorge	Harbor Drive	
Incremental Costs	Capital	\$332,600,000	\$20,700,000	\$455,400,000	\$279,000,000	\$1,073,200,000
	O&M	\$17,300,000	\$300,000	\$22,700,000	\$13,500,000	\$55,000,000
Cumulative Costs	Cumulative Capital Cost	\$332,600,000	\$353,400,000	\$808,800,000	\$1,087,800,000	\$2,160,900,000
	Cumulative O&M Cost	\$17,300,000	\$17,600,000	\$40,300,000	\$53,700,000	\$108,700,000

Note: Capital & O&M Costs shown above are from the Favorable financial model scenario, and include a 20-percent project contingency.

Alternative B3 Unit Cost Summary (2011 \$/AF)

Cost Category	Alternative B3
Gross Costs (Before Avoided Facilities and Other Offset Savings)	\$1,900
Tier 1 Net Costs (With Direct Wastewater System Savings)	\$1,300
Tier 2 Net Costs (With Salt Credit Plus Tier 1 Savings)	\$1,200
Tier 3 Net Costs (With Indirect Wastewater System Savings Plus Tier 1 and Tier 2 Savings)	\$800
2011 Untreated Imported Water Costs (for comparison purposes)	\$904

Note: The reuse water cost summary above represents average costs based on the Favorable and Unfavorable financial model scenarios. See Section 8.4 for more details on the financial evaluation and cost descriptions. Tier 1 savings includes wastewater projects no longer necessary due to the reuse projects and offloading included in this Study. Tier 2 savings accounts for savings due to water quality improvements. Tier 3 conceptualizes the savings that could occur if maintaining chemically enhanced primary treatment at the Point Loma Plant was made possible due to the reuse program proposed in this Study. Costs shown above are for comparison of untreated water options, and do not include potable water treatment plant costs.



What are the Alternative Costs and How Do They Compare with Other Water Supply Costs?

The Integrated Reuse Alternative costs are summarized in the table below. The table includes a tiered breakout of summary level costs based on the Gross Costs and Net Costs categories described earlier in this Executive Summary. As shown, the costs for A1, A2 and B3 are nearly identical to each other, and slightly higher than B1 and B2. For the A1/A2 comparison to B1/B2, the increased costs occur mainly due to the additional wastewater facilities and pumping needed to divert flows from Morena to the North City Plant. For the B3 comparison to B1/B2, B3 adds an additional plant and does not have the same economy of scale that the B1 and B2 Alternatives have. Implementation steps are included later in this Chapter, which include steps to further develop the Alternatives and look for additional cost savings.

Cost Summary (2011 \$/AF)				
Alternative	Average Gross Costs	Net Costs		
		Tier 1 - Direct Wastewater System Savings	Tier 2 - Salt Reduction Credit	Tier 3 - Indirect Wastewater System Savings
		<i>Remaining Point Loma capacity upgraded to Secondary</i>	<i>Water Quality Benefit to Water/Wastewater System</i>	<i>Remaining Point Loma capacity maintained at CEPT</i>
A1: North City 45 mgd; Split Harbor Dr. AWWPF	\$1,900	\$1,300	\$1,200	\$800
A2: North City 45 mgd; Consolidated Harbor Dr. AWWPF	\$1,900	\$1,300	\$1,200	\$800
B1: North City 30 mgd; Split Harbor Dr. AWWPF	\$1,700	\$1,100	\$1,000	\$600
B2: North City 30 mgd; Consolidated Harbor Dr. AWWPF	\$1,700	\$1,100	\$1,000	\$600
B3: North City 30 mgd; Consolidated Harbor Dr. AWWPF; Mission Gorge AWWPF	\$1,900	\$1,300	\$1,200	\$800

Notes:

- All Alternatives include South Bay Option C2 expansion with the Spring Valley No. 8 Diversion
- Direct and indirect wastewater system savings based on a comparison between the City's September 2011 Draft Wastewater Master Plan and the reduced wastewater facility sizing and pumping required as a result of the projects included in this Recycled Water Study (see Appendix H).
- Totals are in 2011 dollars (ENR Los Angeles Index value of 10,051.30, June 2011) and are based on a net present value analysis using a detailed financial model.
- Financial model sensitivity analysis generally produced cost ranging +/- \$200/AF of the values shown. Favorable conditions could result in lower costs than shown.

Key Study Conclusion

The Alternative Net Costs represent the costs that should be compared to other water sources – particularly imported untreated water. The average costs of the Alternatives above are:

- Cost assuming direct wastewater savings = \$1,200/AF
- Cost assuming above plus salt credit = \$1,100/AF
- Cost assuming above plus indirect wastewater savings = \$700/AF

These costs compare well to the 2011 untreated water cost of \$904 per acre foot, and are more economical than most other new water supply concepts being proposed.

The Study Alternative’s Net Costs were extrapolated based on a 3.5-percent inflation rate and compared to projected imported untreated water rate as shown in the figure below. The 2011 SDCWA municipal and industrial untreated water rate for the City was \$904 per acre foot. The existing rate was inflated through 2020 based on the “low-rate” scenario values provided by the SDCWA in April 2011 (which averages to a 5.8-percent annual increase). Beyond 2020, the untreated water cost projections were bracketed based on various inflation scenarios ranging from 3 to 6 percent (shown as the shaded area). These scenarios compare well to the Net Costs of the Study’s Alternatives (shown as solid lines). The Study’s Net Costs shown are the average of all the Study Alternatives and an average of the Favorable and Unfavorable scenario (i.e., the lower cost B1/B2 Alternatives and the favorable scenario would lower the reuse costs further). As shown, the average Tier 1 and Tier 2 cost curves have Net Costs lower than most untreated imported water rate scenarios. If the Tier 3 savings are attributed to the projects in this Study, the program would have significantly lower Net Costs than all untreated imported water rate scenarios. An additional consideration is the long-term effects that other local water projects and reduced demands are causing to MWD/SDCWA rates. As purchases decline, rates must increase to cover fixed costs. This is likely to cause imported water costs to inflate faster than locally controlled projects. Overall, the conclusion of this analysis supports the water reuse program proposed in this Study.

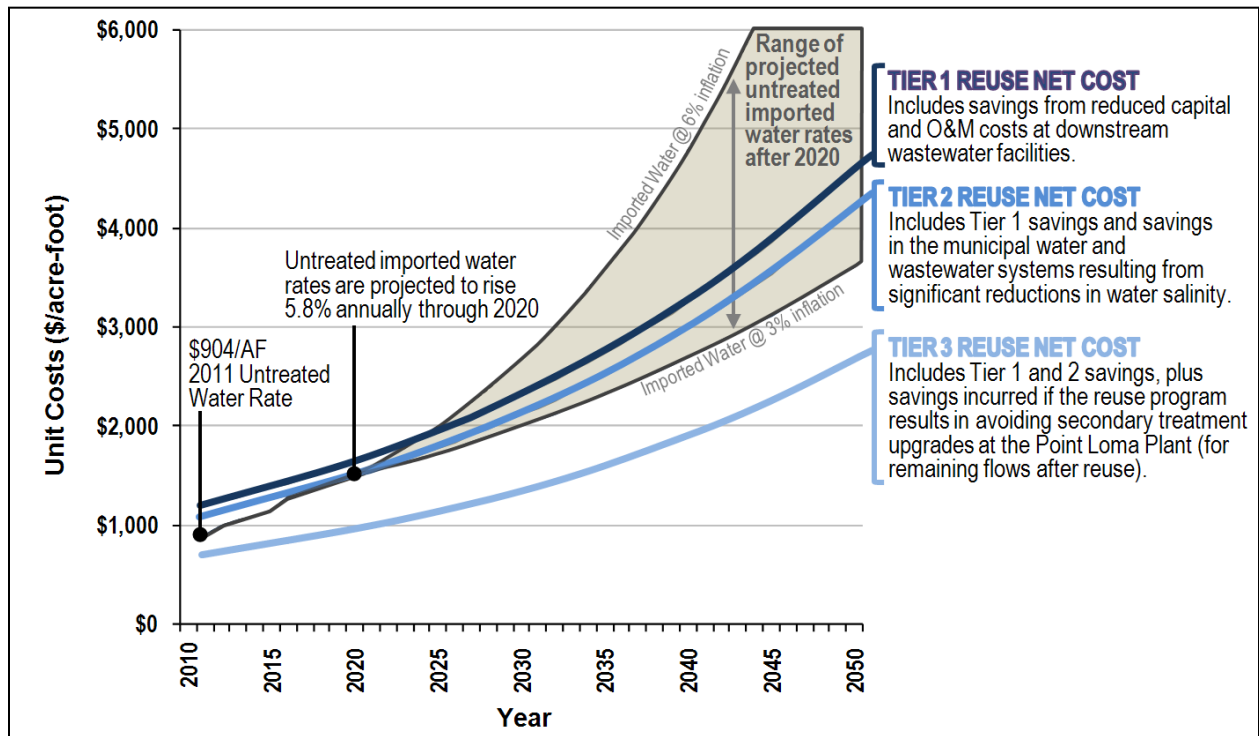

Comparison of the Study’s Unit Costs for New Water to the Cost of Imported Untreated Water

The Integrated Reuse Alternative Net Costs compare well to projected untreated imported water rates. Untreated water rates are projected to rise 5.8 percent through 2020 and there remain many uncertainties regarding future costs associated with the Bay-Delta fix and imported water.



What Were the Other Considerations for Each Alternative?

The Integrated Reuse Alternatives were evaluated during the Fine Screening Session and subsequent Stakeholder Status Update Meetings. Each Integrated Reuse Alternative provides common and distinct benefits, as summarized below.

Integrated Reuse Alternative Comparative Summary					
Alternative	Institutional Complexity	Technical Complexity	Number of Treatment Plants	Number of Wastewater Diversions	Key Infrastructure Siting and Complexity Considerations
A1	Med	High (Morena Diversion/Split Plant Harbor Drive-Camino del Rio)	4 North City, South Bay, Harbor Drive (WRP) w/ Camino del Rio (AWPF)	2	<ul style="list-style-type: none"> • Smallest area requirement at the Harbor Drive site • Challenging siting at Camino del Rio site • Challenging siting and operation of the Morena Wastewater Diversion Pump Station • Most pumping of all alternatives due to Morena Diversion • Increased costs due to added brine line
A2	Med	Med/High (Morena Diversion)	3 North City, South Bay Harbor Drive	2	<ul style="list-style-type: none"> • Reduced Harbor Drive Plant siting needs compared to the "B" alternatives • Challenging siting and operation of the Morena Wastewater Diversion Pump Station
B1	Med	Med/High (split Plant Harbor Drive-Camino del Rio)	4 North City, South Bay, Harbor Drive (WRP) w/ Camino del Rio (AWPF)	1	<ul style="list-style-type: none"> • Reduced Harbor Drive Plant siting needs compared to B2 • Minimal wastewater pumping • Challenging siting at the Camino del Rio site • Reduced ability to phase • Increased costs due to added brine line
B2	Med	Med	3 North City, South Bay, Harbor Drive	1	<ul style="list-style-type: none"> • Largest area requirement at the Harbor Drive site • Least cost option • Minimal wastewater and tertiary water pumping • Reduced ability to phase
B3	High (Harbor Drive site & Mission Gorge site)	High (4th Water Reclamation Plant/ Advance Water Purification Facility at Mission Gorge)	4 North City, South Bay, Harbor Drive, Mission Gorge	1	<ul style="list-style-type: none"> • Multiple agency collaboration could drive further economy of scale benefits • Allows for additional phasing opportunities • Closest plant to San Vicente Reservoir reduces overall pumping • Mission Gorge site requires interagency agreements and administration costs • Mission Gorge Plant is relatively small due to limited tributary wastewater flows. It does not have an economy of scale benefit and reduces some economy of scale benefit at the Harbor Drive Plant • Larger upstream treatment at Mission Gorge Plant impacts downstream water quality at Harbor Drive Plant • Reduced flows/concentrated waste downstream of Mission Gorge Plant may create maintenance issues

Notes:

- Alternative A1 and B1 include a split Harbor Drive Plant at the Harbor Drive site and Camino del Rio site. Although these facilities work together, they were considered separate treatment plant sites in the table above.
- Wastewater Diversions can include the Morena diversion to the North City Plant and the Spring Valley No. 8 Diversion to the South Bay Plant. These diversions require wastewater pump stations.
- South Bay facilities not included above since common to all Alternatives.

Why is Adaptability Important?

The implementation of this reuse plan will need to be adaptable to anticipated and unanticipated needs. Adaptability may be triggered based on financial constraints, changes in regulatory requirements, institutional coordination issues, favorable or unfavorable political and community support, and technical issues. The project implementation proposed below provides a number of key actions to help implement this reuse program and maximize adaptability to changing conditions.

How Will the Projects be Implemented?

Implementing the Integrated Reuse Alternatives involves a step-by-step process as shown in the figure below. Although part of the implementation process includes common elements regardless of the alternative, it is important to note that the latter steps are affected by these earlier phase projects. Therefore, implementation considerations are important even during the first phase projects.

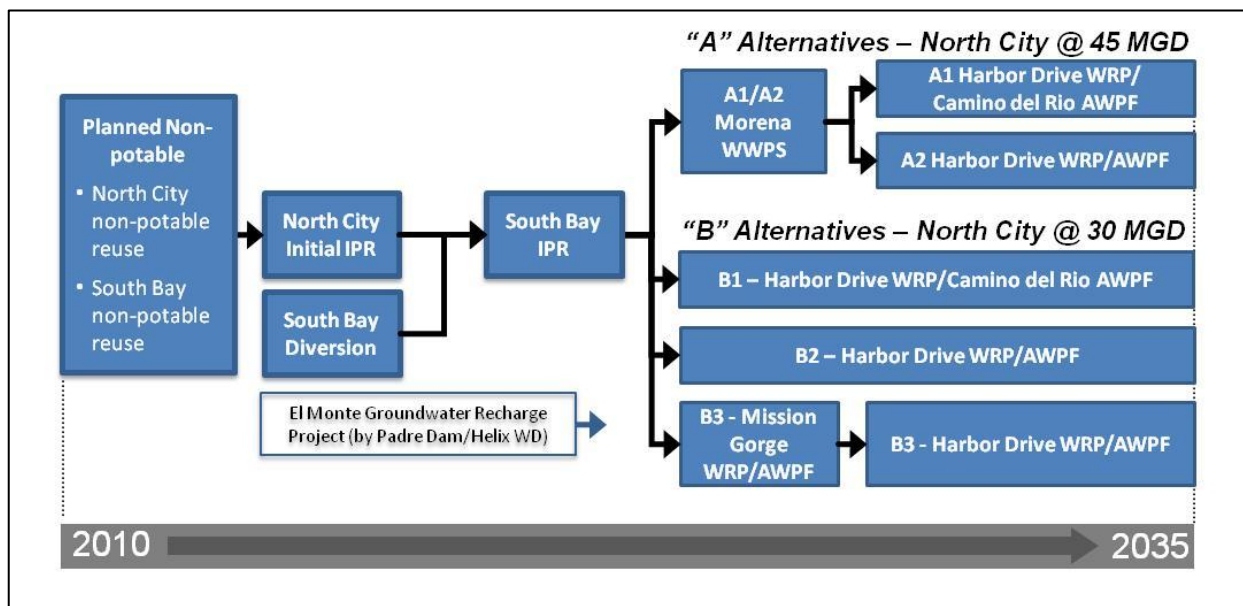

Recycled Water Study Project Implementation Summary
 The implementation plan summarizes the basic roadmap to complete the reuse plan.

What are Specific Implementation Steps Needed Directly Following this Study?

Achieving the benefits identified in this Study requires an investment. Some of these investments have already been started, such as the Water Purification Demonstration Project now operating at the North City Plant. To proceed to the next steps in this study, additional investments will be needed to plan and develop the program to a level of detail that can be designed, permitted and constructed. These investments are referred to as program implementation steps. The following pages organize and summarize these key implementation steps into an Implementation Checklist.



IMPLEMENTATION CHECKLIST: REGULATORY, INSTITUTIONAL, POLICY & FINANCE

General

- Develop timeline for implementation steps outlined below.

Water Purification Demonstration Project/Permitting. The Water Purification Demonstration Project (Demonstration Project) and the San Vicente flow modeling are key steps of the public involvement and regulatory permitting processes to confirm the health and safety of the new water supply.

- Obtain Advanced Water Purification Facility water quality and San Vicente limnology model final results.
- Provide on-going public involvement and community outreach.
- Coordinate with CDPH and the Regional Water Quality Control Board on processes and permitting (whether through uniform criteria being developed by CDPH or project specific criteria).
- Promote advocacy by Stakeholder groups with CDPH and the Regional Water Quality Control Board.

Mayor and City Council. Support from the Mayor and City Council is essential to implement such an important program. While the reuse program appears to offer substantial cost savings to ratepayers (compared to upgrading the Point Loma Plant for the full-scale flows), support from policymakers to advance the program will be needed.

- Obtain Independent Rates Oversight Committee support.
- Obtain Natural Resources and Culture Committee approval.
- Obtain stakeholder advocacy support of the Study by the Metro JPA, Independent Rates Oversight Committee, environmental groups, and other interested parties.
- Obtain City Council approval.
- Coordinate implementation with broader water policy issues and programs.

Metro JPA Approval. As partners in the Metro System, support from the Metro JPA is also essential to implement such an important program. Support from JPA policymakers is needed to advance the program.

- Finalize the cost sharing framework, as summarized below. This includes policy and legal issues, costs and consensus.
- Promote stakeholder advocacy in support of the Study by the City, Independent Rates Oversight Committee, environmental groups, and other interested parties.
- Obtain Policymaker support and accept the Study and the reuse program.

Financials/Policy. Fiscal responsibility is important for all parties. For Water and Wastewater ratepayers, there is an important choice required regarding whether to fund this water reuse plan or potentially fund full-scale improvements at the Point Loma Plant.

- Complete discussions on cost share framework concepts and agreements, clarify City and Participating Agency costs, and clarify sources for offset such as the salt credit.
- Provide comparative financial analyses with other alternative water sources (if desired).
- Determine/develop policy on local resource program funding from SDCWA/MWD.
- Determine SDCWA policy on regional supply benefits, interest in joint participation, and potential rate impacts/savings.
- Seek out and apply for grants.
- Develop rate impacts and a detailed financing plan.
- Provide funding and staff to move forward with the program implementation, including the activities needed for near-term and long-term projects.
- Develop policy on SBx7-7 stemming from new locally produced water supply.

IMPLEMENTATION CHECKLIST: PERMITTING & TECHNICAL

Permitting. Implementing the reuse plan will require addressing key permitting activities:

- Point Loma Permitting. Continue permitting coordination amongst Stakeholders as part of the Point Loma Plant 301(h) Modified Permit process. These discussions are assumed to be related to the cost sharing discussions outlined above.
- Project Permitting. Identify, evaluate and obtain permits needed to complete the reuse projects.

Technical/Other. Implementing the reuse plan will require technical evaluations and engineering:

- Reuse Program/wastewater planning process coordination. On-going coordination between the proposed reuse program and wastewater planning efforts to refine facilities and costs in support of the cost sharing discussions and Point Loma permitting process.
- North City treatment. Determine the North City treatment approach (existing filters, feed source, recovery rates, improvements to the treatment processes upstream of the filters, the fate of the electro dialysis reversal units, and other technical design parameters).
- Non-potable reuse demands and wastewater flow confirmation. Continue to evaluate non-potable reuse demands and use trends; and wastewater flow generation. These totals will be important to finalize the size of indirect potable reuse projects.
- New facility siting. Develop detailed siting studies for new pump stations and treatment plants, including evaluation and confirmation of availability of the Harbor Drive and Camino del Rio sites.
- Wastewater treatment pilot testing. Test treatment strategies and high rate systems to develop area-specific design values.
- New conveyance facility alignments. Perform alignment studies for new conveyance facilities.
- SV8 Diversion to South Bay. Update the SV8 Pump Station Predesign and Sweetwater River crossing. Coordinate efforts between the Recycled Water Study needs and the September 2011 Draft Wastewater Master Plan (or any updates) needs.
- South Bay Plant. Continue discussion and coordination on South Bay Plant issues, particularly sizing and timing needed for reuse based on recent revisions to the September 2011 Draft Wastewater Master Plan. Key coordination issues include South Bay timing (both from reuse and wastewater perspectives), and the biosolids approach strategy. This includes evaluating/determining whether biosolids will be treated at the South Bay Plant at a dedicated facility instead of continuing to send it to the Point Loma Plant and the MBC for treatment. These coordination items will aid in determining cost responsibilities as outlined in the financial implementation steps above.
- South Bay indirect potable reuse delivery. Perform detailed evaluation of the South Bay Plant expansion including pump station and delivery pipeline to Otay Lakes.
- Otay Lakes operation. Perform an Otay Lakes operational evaluation in relation to local runoff and indirect potable reuse operation to confirm flow rates and optimal project sizing. Develop a hydraulic model similar to those developed for the San Vicente Reservoir to determine seasonal hydraulic patterns within the Otay Lakes system.
- Joint Project Evaluation. Identify opportunities of joint projects, such as brine pipelines or indirect potable reuse delivery pipelines coordinated with other regional projects.

IMPLEMENTATION CHECKLIST: PERMITTING & TECHNICAL (Continued)

- Mission Gorge Plant Evaluations. Coordinate further discussion and evaluation on the merits of a joint plant with Padre Dam Municipal Water District in the Mission Gorge area (conceptualized in Alternative B3). Evaluate possible additional savings at the East Mission Gorge Pump Station and additional avoided facility savings in downstream facilities.
- Groundwater updates. Complete groundwater studies including evaluation of the San Diego Formation and San Diego River system for possible inclusion into future master planning efforts. Update the status of other County groundwater studies including San Pasqual and Padre Dam Municipal Water District's studies.
- Waste stream recovery. Evaluate waste stream efficiency and recovery analysis to evaluate ways to further minimize waste streams and explore beneficial uses.
- San Vicente regulatory limits and operational coordination. Perform San Vicente analysis to evaluate maximum potential indirect potable reuse. If it is limited, determine options such as further evaluation of the San Diego formation or integration with other reservoirs. Coordinate reuse operational activities with other San Vicente operations after the dam raise is complete.
- Regulatory update on minimum reservoir capacities. Check assumptions on smaller sized reservoirs (Lakes Murray, Miramar and Jennings) once indirect potable reuse reservoir augmentation regulations are finalized.
- SDCWA Coordination. Coordinate with SDCWA on their Master Plan (currently underway), broader water policy support at the state level, and possible regional collaboration involving funding.
- Peak Wet Weather Flow strategies. Continue to evaluate fail-safe disposal strategies under wet weather conditions, including equalization, live stream discharge, and CEPT-secondary effluent blending at the Point Loma Plant.
- Santee Basin Aquifer Project. Continue to evaluate this project which is currently under study by the Bureau of Reclamation for Padre Dam Municipal Water District. Preliminary planning numbers put the capacity of the first site considered to be between 1.5 mgd and 3 mgd of groundwater recharge capacity.
- Helix Water District IPR Project. Continue to evaluate this project where Helix Water District is considering an option to send advanced treated recycled water to Lake Jennings Reservoir as part of a reservoir augmentation IPR project.

Study Results and Conclusions

The overarching goal of the Recycled Water Study (Study) was to evaluate ways to increase water reuse as a means of providing safe, reliable water supplies; to reduce ocean discharges; and to offload the Point Loma Plant. Over the course of the Study, representatives from the Study area's water and wastewater agencies, environmental groups, a representative from the Independent Rates Oversight Committee and independent technical reviewers participated in developing the water reuse program outlined below. These Stakeholders provided valuable opinions and diverse viewpoints that added value to the process and the alternatives developed. Overall, the Integrated Reuse Alternatives presented achieve the Study's goals, provide a bold vision for future water reuse, and provide savings to ratepayers. While water reuse has been evolving in San Diego over the past few decades, the region's master plans have helped guide decision makers with a focus on making good investments, while still being flexible to adapt to future changes. This Study endeavors to continue this tradition and be looked upon as a milestone that helped provide long-term water sustainability to the San Diego region.

What are the Primary Study Results?

Alternatives. Five Integrated Reuse Alternatives were developed based on an extensive, interactive Stakeholder process. Each Alternative includes 83 mgd of new indirect potable reuse and 3 mgd of new non-potable recycled (in addition to 4 mgd of already planned non-potable reuse).

Costs. The 2011 Net Cost results for the Alternatives in this Study represent the costs that should be compared to other water sources – particularly imported untreated water. The average Net Costs are:

- Net Cost assuming direct wastewater savings = \$1,200/AF
- Net Cost assuming above plus salt credit = \$1,100/AF
- Net Cost assuming above plus indirect wastewater savings = \$700/AF

What are the Primary Study Conclusions?

Achieves Favorable Water Costs. The reuse costs above are comparable to 2011 untreated imported water delivery costs of \$904/AF, and are projected to be more economical than future water costs. Imported water costs have risen substantially in the past decade and this trend is projected to continue into the foreseeable future. Therefore, this new water supply will provide safe, affordable water for existing and future generations of San Diegans.

Provides Reliability and Local Control. The new reuse supply reduces the region's reliance on imported water and increases local water supply reliability. Local reuse is considered an uninterruptable water source – an important trait since our imported water supply crosses great distances and major earthquake faults.

Enhances Sustainability. The reuse solutions are more sustainable and environmentally friendly. They reduce importing water from Northern California and the Colorado River, lowering energy usage and our overall carbon footprint.

Improves Water Quality. The reuse solutions produce additional water quality benefits such as significant regional salinity reductions. Ratepayers will see reduced salinity in the water – appliances, water heaters and fixtures will last longer. In addition, ocean discharges are reduced resulting in ocean water quality benefits.

Empowers Long-term Cost Control. The solutions increase the City and Participating Agencies' ability to control long-term water and wastewater costs by reducing liability for pending issues such as the California Bay-Delta fix and costly wastewater treatment upgrades.

Supported by Stakeholders. The solutions are supported by rate oversight and environmental group Stakeholder representatives.



Where Can I Find More Information on Water Reuse in the City?



Website. The Public Utilities Department maintains useful information on the City's website. See below for more information.

Recycled Water Home Page. The City's Recycled Water homepage includes extensive information on water reuse, rules and regulations, information on the existing system, and frequently asked questions. The website address is: <http://www.sandiego.gov/water/recycled/>



Water Reuse Homepage. The Water Reuse homepage includes links to the 2005 Water Reuse Study, the Water Purification Demonstration Project, and the Full Scale Reservoir Augmentation Page. The website address is: <http://www.sandiego.gov/water/waterreuse/>

General Information. If you are interested in learning more about recycled water, the City's Public Utilities Department can be contacted at (619) 533-7572 or e-mail at water@sandiego.gov.

Community Presentations. Recycled water professionals are available to speak to your community group, organization, special interest club or service organization. They are qualified to deliver their expertise, answer your recycled water questions, and will customize a presentation to meet the needs of your group. To schedule a speaker, simply call our Speakers Bureau Hotline at (619) 533-6638 at least two weeks prior to your program date. Or, you may e-mail requests to waterspeakers@sandiego.gov.

Who Can I Contact for More Information on this Study?

The project team consisted of City staff from the Public Utilities Department, and a consulting team from Brown and Caldwell, Black & Veatch, and CDM.



City of San Diego Contacts

600 B Street
Suite 700, MS 907
San Diego, CA 92101-4587

Marsi Steirer, Deputy Director

msteirer@sandiego.gov
(619) 533-4112

Amy Dorman, P.E., Senior Project Manager

adorman@sandiego.gov
(619) 533-5248

Amer Barhoumi, P.E., Project Manager

abarhoumi@sandiego.gov
(619) 533-4186



Consultant Team Contacts

Victor Occiano, P.E., Co-Project Manager

Brown and Caldwell
vocciano@brwnald.com
(858) 571-6715

9665 Chesapeake, Suite 201
San Diego, CA 92123

James Strayer, P.E., Co-Project Manager

Black & Veatch
strayerjj@bv.com
(760) 525-6230
300 Rancheros Drive, Suite 250
San Marcos, CA 92069



TABLE OF CONTENTS

LIST OF FIGURES.....	VII
LIST OF TABLES.....	IX
LIST OF ACRONYMS AND ABBREVIATIONS	X
1. STUDY OVERVIEW.....	1-1
1.1 Study Background	1-1
1.2 Study Objective and Approach	1-1
1.3 Study Stakeholders.....	1-3
1.4 Study Process Overview.....	1-3
1.5 Technical Memoranda Overview	1-4
1.6 Important Terminology Used in this Report	1-4
2. WATER REUSE NEED AND RELATED ACTIVITIES	2-1
2.1 Water Supply and Water Reuse as a Local Supply Source.....	2-1
2.2 Metro System Overview.....	2-1
2.3 Key Studies and Activities	2-2
2.3.1 2005 Water Reuse Study.....	2-2
2.3.2 Water Purification Demonstration Project	2-3
2.3.3 Independent Technical Panels.....	2-3
2.3.4 2010 Recycled Water Master Plan Update	2-4
2.4 Other Studies and Information.....	2-4
3. STUDY PROCESS AND EVALUATION APPROACH	3-1
3.1 Process.....	3-1
3.2 Work Session Summary	3-1
3.3 Stakeholder Status Update Meetings	3-2
3.4 Adaptive Model.....	3-3
3.4.1 Guidelines for what Opportunities were Considered.....	3-3
3.5 Criteria Used to Assess Water Reuse Alternatives.....	3-4
4. KEY FACILITIES, WATER DEMANDS, AND WASTEWATER FLOWS	4-1
4.1 Potable Water System and Demands.....	4-1
4.2 Recycled Water System and Demands	4-2
4.2.1 Water Reclamation Plants	4-2
4.2.2 Recycled Water Conveyance System.....	4-7
4.3 Wastewater System.....	4-8
4.3.1 Point Loma Plant	4-9
4.3.2 Metropolitan Biosolids Center	4-10
4.4 Wastewater Flows	4-10
4.4.1 Point Loma Plant Influent Flows	4-10



4.4.2	Wastewater Flow Scenarios and Application in this Study	4-11
4.4.3	North City Plant Influent Flows.....	4-12
4.4.4	South Bay Plant Influent Flows.....	4-13
4.4.5	Wastewater Flows and Losses through Treatment Processes	4-13
4.4.6	Water Losses from Treatment Process	4-17
5.	NON-POTABLE RECYCLED WATER OPPORTUNITIES.....	5-1
5.1	Non-potable Recycled Water Opportunities Summary	5-1
5.2	Baseline Non-potable Recycled Water Demands.....	5-1
5.3	Future Non-potable Recycled Water Opportunities	5-2
5.3.1	Future Citywide Non-potable Recycled Water Opportunities.....	5-3
5.3.2	Future Wholesale Non-potable Recycled Water Opportunities.....	5-4
5.3.3	Other Agency Reclamation Plant Considerations	5-4
5.4	Non-potable Recycled Water Carried Forward in the Study.....	5-5
5.4.1	Seasonal Demand Considerations	5-6
6.	INDIRECT POTABLE REUSE OPPORTUNITIES.....	6-1
6.1	Indirect Potable Reuse Summary	6-1
6.2	Indirect Potable Reuse Benefits	6-2
6.3	Indirect Potable Reuse Opportunities	6-3
6.3.1	Reservoir Augmentation Opportunities	6-3
6.3.2	Groundwater Recharge Opportunities Considered	6-6
6.4	Direct Potable Reuse Considerations	6-9
7.	AREA CONCEPTS	7-1
7.1	Area Concept Sub-regions	7-1
7.2	Area Concept Background.....	7-2
7.3	Initial North City/San Vicente Area Concepts	7-3
7.3.1	Coarse Screening Session Conclusions on North City/San Vicente Area Concepts.....	7-4
7.3.2	Modifying the North City/San Vicente Area Concepts.....	7-4
7.3.3	Preliminary Siting Evaluation	7-4
7.3.4	Harbor Drive Site's Strategic Importance.....	7-5
7.3.5	Harbor Drive Facility Options to Minimize Site Needs	7-6
7.4	Revised North City/San Vicente Area Concepts.....	7-7
7.4.1	North City/San Vicente Themes A1 and A2.....	7-10
7.4.2	North City/San Vicente Themes B1, B2 and B3.....	7-12
7.5	South Bay Area Concepts	7-15
7.5.1	South Bay Wastewater Diversions.....	7-16
7.5.2	South Bay Area Concepts Flow Summary.....	7-18
7.5.3	Wet Weather Flow Considerations at South Bay	7-18
7.6	Rancho Bernardo/San Pasqual Area Concepts.....	7-18
7.6.1	Rancho Bernardo/San Pasqual Area Concept Options	7-19
7.6.2	Rancho Bernardo/San Pasqual Area Concept Conclusions	7-19
7.7	Area Concept Conclusions	7-20

8. INTEGRATED REUSE ALTERNATIVES.....8-1

 8.1 Establishing the Study’s Water Reuse Target8-1

 8.1.1 Previous and Current Study Target Basis.....8-1

 8.1.2 Water Supply Considerations for the Water Reuse Target8-1

 8.1.3 Water Quality Considerations for the Water Reuse Target.....8-2

 8.1.4 Project Size Considerations for the Water Reuse Target8-2

 8.1.5 Cost Considerations for the Water Reuse Target8-2

 8.2 Integrated Reuse Alternatives Summary8-3

 8.2.1 Summary of Integrated Reuse Alternatives A1 and A2.....8-5

 8.2.2 Summary of Integrated Reuse Alternatives B1 and B2.....8-7

 8.2.3 Summary of Integrated Reuse Alternative B3.....8-9

 8.3 Evaluation Summary for the Integrated Reuse Alternatives8-11

 8.4 Financial Evaluation of Alternatives8-12

 8.4.1 Financial Model Cost Components8-12

 8.4.2 Comparative Costs Basis Using a Sensitivity Analysis8-13

 8.4.3 Gross Costs8-13

 8.4.4 Net Costs8-14

 8.4.5 Cost Summary for Integrated Reuse Alternatives.....8-15

 8.5 Adaptability and Implementation.....8-21

 8.5.1 Implementation Summary8-22

 8.5.2 General8-22

 8.5.3 Water Purification Demonstration Project/Permitting8-22

 8.5.4 Mayor and City Council.....8-23

 8.5.5 Metro JPA Approval.....8-23

 8.5.6 Financials/Policy8-23

 8.5.7 Permitting.....8-24

 8.5.8 Technical/Other8-24

 8.5.9 Cost Sharing Implementation Considerations.....8-25

 8.5.10 Point Loma Plant Improvements During Implementation.....8-27

 8.5.11 Harbor Drive Facility Implementation8-27

 8.5.12 Pipeline Phasing between the North City Plant and the San Vicente Reservoir8-27

 8.6 Conclusion.....8-28

9. STUDY OUTREACH AND APPROVALS.....9-1



CONTACTS	CON-1
GLOSSARY	GLO-1
LIMITATIONS	LIM-1
REFERENCES	REF-1
APPENDIX A: COOPERATIVE AGREEMENT	A-1
APPENDIX B: POINT LOMA WASTEWATER TREATMENT PLANT CONCLUSIONS	B-1
APPENDIX C: SUMMARY OF REGULATIONS THAT AFFECT WATER, WASTEWATER AND RECYCLED WATER	C-1
APPENDIX D: SENATE BILL 918.....	D-1
APPENDIX E: SITING ANALYSIS DOCUMENTS	E-1
APPENDIX F: CONCEPTUAL COST ESTIMATES FOR THE INTEGRATED REUSE ALTERNATIVES	F-1
APPENDIX G: NATIONAL WATER RESOURCE INSTITUTE WHITE PAPER.....	G-1
APPENDIX H: RECYCLED WATER STUDY COST METHODOLOGY FREQUENTLY ASKED QUESTIONS	H-1
APPENDIX I: PARTICIPATING AGENCIES WHITE PAPER	I-1
APPENDIX J: COMMENT/RESPONSE FORM	J-1
APPENDIX K: CONCEPTUAL METRO SYSTEM FLOW SCHEMATICS.....	K-1
APPENDIX L: METRO JPA LETTER.....	L-1
APPENDIX M: CITY COUNCIL RESOLUTION	M-1



LIST OF FIGURES

Figure 1-1. Metropolitan Sewerage System Service Area/Metro JPA Members	1-2
Figure 1-2. Study Process for the Recycled Water Study	1-3
Figure 2-1. Water Purification Demonstration Project	2-3
Figure 2-2. Recycled Water Master Plan Relationship to the Recycled Water Study.....	2-4
Figure 3-1. Framework Planning Session	3-1
Figure 3-2. Adaptive Model	3-3
Figure 4-1. Regional Water Infrastructure Related to the Reuse Alternatives in the Study	4-2
Figure 4-2. North City Water Reclamation Plant Treatment Process Schematic.....	4-3
Figure 4-3. North City Water Reclamation Plant Non-potable Recycled Water Output.....	4-4
Figure 4-4. South Bay Plant Treatment Process Schematic	4-5
Figure 4-5. South Bay Plant Non-potable Recycled Water Output.....	4-6
Figure 4-6. Non-potable Recycled Water Conveyance System	4-8
Figure 4-7. Metropolitan Sewerage System	4-9
Figure 4-8. Point Loma Plant Process Schematic	4-10
Figure 4-9. Point Loma Plant Daily Average Influent Flow and Rainfall Data for 2003 to 2011.....	4-11
Figure 4-10. Elements that Make Up the Flow Projections.....	4-13
Figure 4-11. Schematic of the Metro System's North Area Trunk Sewers	4-15
Figure 4-12. Schematic of the Metro System's South Area Trunk Sewers.....	4-16
Figure 4-13. Typical Water Losses in Water Reclamation and Advanced Water Purification Treatment Processes.....	4-17
Figure 5-1. Non-potable Recycled Water Opportunity Development.....	5-2
Figure 5-2. Non-potable Recycled Water Opportunity Density Map.....	5-3
Figure 5-3. Projected Non-potable Recycled Water Demands.....	5-5
Figure 5-4. Seasonal Demand Analysis at the North City Plant	5-7
Figure 5-5. Seasonal Demand Analysis at the South Bay Plant.....	5-8
Figure 6-1. Surface Water Reservoirs Considered.....	6-3
Figure 6-2. Groundwater Basins Considered	6-6
Figure 7-1. Area Concepts Were Constructed to Provide Detailed, Comparable Options for Discussion at the Coarse Screening Session and Stakeholder meetings	7-1
Figure 7-2. Area Concept Sub-regions.....	7-1
Figure 7-3. Initial North City/San Vicente Area Concepts.....	7-3
Figure 7-4. Refined North City/San Vicente Area Concepts.....	7-7
Figure 7-5. Schematic of Theme A1.....	7-10
Figure 7-6. Schematic of Theme A2.....	7-11
Figure 7-7. Schematic of Theme B1.....	7-12
Figure 7-8. Schematic of Theme B2.....	7-13
Figure 7-9. Schematic of Theme B3.....	7-14
Figure 7-10. Schematic of South Bay Options	7-15
Figure 7-11. South Bay C2 Area Concept.....	7-16
Figure 7-12. South Bay Wastewater Diversions.....	7-17
Figure 7-13. Schematic of Rancho Bernardo/San Pasqual Area Concepts.	7-19



Figure 7-14. Rancho Bernardo/San Pasqual Option A.....	7-20
Figure 7-15. Rancho Bernardo/San Pasqual Option B.....	7-20
Figure 7-16. Schematic of Rancho Bernardo/San Pasqual Option C.....	7-20
Figure 8-1. Integrated Reuse Alternatives are Area Concepts Compiled to Meet a Water Reuse Target Based on the Study's Goals and Objectives	8-1
Figure 8-2. Integrated Reuse Alternatives A1 and A2	8-5
Figure 8-3. Alternative A1/A2 Implementation Schedule.....	8-6
Figure 8-4. Integrated Reuse Alternatives B1 and B2	8-7
Figure 8-5. Alternative B1/B2 Implementation Schedule.....	8-8
Figure 8-6. Integrated Reuse Alternative B3	8-9
Figure 8-7. Alternative B3 Implementation Schedule	8-10
Figure 8-8. Comparison of Reuse Alternative Net Costs to Imported Untreated Water	8-18
Figure 8-9. Reuse Plan Summary	8-22

LIST OF TABLES

Table 3-1. Evaluation Criteria	3-5
Table 4-3. Projected Dry Weather Flows at Specified Locations in the Metro System.....	4-14
Table 5-1. Baseline Non-potable Recycled Water Annual Demands	5-2
Table 5-2. Citywide Future Non-potable Recycled Water Opportunities Considered	5-3
Table 5-3. Non-potable Recycled Water Projected Demands	5-6
Table 6-1. Surface Water Reservoir Candidates Advanced	6-4
Table 6-2. Surface Water Reservoir Candidates Not Advanced	6-5
Table 6-3. Groundwater Basin Candidates Advanced	6-7
Table 6-4. Groundwater Basin Candidates Not Advanced	6-8
Table 7-1. North City/San Vicente Area Concept Summary – Included Elements	7-8
Table 7-2. North City/San Vicente Area Concept Summary – 2035 Dry Weather Flows	7-9
Table 7-3. North City/San Vicente Area Concept Summary – Pumping.....	7-9
Table 7-4. South Bay Area Concepts Summary – Included Elements	7-15
Table 7-5. Wastewater and Tertiary Water Availability in 2035 for South Bay	7-17
Table 7-6. South Bay Area Concepts Summary.....	7-18
Table 8-1. Integrated Reuse Alternative Summary - Elements Included.....	8-3
Table 8-2. Alternative A1/A2 New Water and Point Loma Offloading (Totals in mgd)	8-6
Table 8-3. Alternative A1/A2 Capital and Annual O&M Costs	8-6
Table 8-4. Alternative A1/A2 Reuse Water Cost Summary (2011 \$/AF).....	8-6
Table 8-5. Alternative B1/B2 New Water and Point Loma Offloading (Totals in mgd)	8-8
Table 8-6. Alternative B1/B2 Capital and Annual O&M Costs	8-8
Table 8-7. Alternative B1/B2 Unit Cost Summary (2011 \$/AF).....	8-8
Table 8-8. Alternative B3 New Water and Point Loma Offloading (Totals in mgd).....	8-10
Table 8-9. Alternative B3 Capital and Annual O&M Costs	8-10
Table 8-10. Alternative B3 Unit Cost Summary (2011 \$/AF).....	8-10
Table 8-11. Integrated Reuse Alternative Comparative Summary	8-11
Table 8-12. Gross Costs Variables.....	8-14
Table 8-13. Net Cost Variables	8-15
Table 8-14. Cost Summary (2011 \$/AF).....	8-16
Table 8-15. Financial Details for the Favorable Scenario.....	8-19
Table 8-16. Financial Details for the Unfavorable Scenario	8-20



LIST OF ACRONYMS AND ABBREVIATIONS

AADF (10-year)	Annual Average Daily Flow with a 10-year storm event	PA	Participating Agency
AF	acre-feet	Padre Dam	Padre Dam Municipal Water District
AFY	acre-feet per year	Point Loma Plant	Point Loma Wastewater Treatment Plant
AWPF	Advanced Water Purification Facilities	PS	Pump Station
		PS1	Pump Station No. 1
		PS2	Pump Station No. 2
BOD	biochemical oxygen demand	PS64	Pump Station 64
CDPH	California Department of Public Health	SANDAG	San Diego Association of Governments
CEC	chemicals of emerging concern	SB 918	Senate Bill 918
CEPT	Chemically Enhanced Primary Treatment	SDCWA	San Diego County Water Authority
Chapman Plant	Ralph W. Chapman Water Recycling Facility	South Bay Plant	South Bay Water Reclamation Plant
City	City of San Diego	Study	Recycled Water Study
		SV8	Spring Valley 8
EPA	Environmental Protection Agency	SWRCB	State Water Resources Control Board
HARRF	Hale Avenue Resource Recovery Facility	TAC	Technical Advisory Board
		TDS	total dissolved solids
IPR	Indirect Potable Reuse	TSS	total suspended solids
IROC	Independent Rates Oversight Committee		
		U.S.	United States
LRP	Local Resource Program	USBR	United States Bureau of Reclamation
		UWMP	Urban Water Management Plan
MBC	Metropolitan Biosolids Center		
MBR	membrane bioreactor	WRP	Water Reclamation Plant
MER	mass emission rate	WTP	Water Treatment Plant
Metro JPA	Metropolitan Wastewater Joint Power Authority	WWMP	Wastewater Master Plan
Metro System	Metropolitan Sewerage System		
mgd	million gallons per day		
Metro Service Area	Metropolitan Sewerage System Service Area		
MWD	Metropolitan Water District of Southern California		
MWWD	City of San Diego Public Utilities Metropolitan Wastewater Department		
North City Plant	North City Water Reclamation Plant		
NPDES	National Pollutant Discharge Elimination System		
NWRI	National Water Research Institute		
O&M	operations and maintenance		

1. STUDY OVERVIEW

In August 2009, the City of San Diego (City), along with key stakeholders, initiated the Recycled Water Study (Study). This Study summarizes the technical evaluations performed, stakeholder participation, and the integrated reuse alternatives developed. This document is intended to serve as a guidance document to help inform policy leaders about the important decisions ahead regarding water reuse and our water and wastewater infrastructure.

1.1 Study Background

On June 16, 2010, the San Diego Regional Water Quality Control Board and United States (U.S.) Environmental Protection Agency (EPA) adopted Order No. R9-2009-0001 (National Pollutant Discharge Elimination System (NPDES) Permit No. CA0107409) allowing the City to continue to operate the Point Loma Wastewater Treatment Plant (Point Loma Plant) as a chemically enhanced primary treatment (CEPT) facility. The Permit, which became effective on August 1, 2010, allows the City to continue operating the Point Loma Plant in this fashion for five years until July 31, 2015, when the permit must be renewed. During the 2008 to 2010 permit modification process the San Diego Coastkeeper and Surfrider Foundation entered into a Cooperative Agreement (see Appendix A) with the City to conduct a Recycled Water Study. In accordance with the Cooperative Agreement, the environmental community did not oppose the U.S. EPA's decision to grant the modification. The City's responsibility per the Cooperative Agreement is to execute this Study, which is also consistent with the City's long-term goals and objectives.

This Study, based on the Cooperative Agreement, focuses on the Metropolitan Sewerage System (Metro System) which serves the City of San Diego and the Metropolitan Wastewater Joint Power Authority (Metro JPA), as shown on Figure 1-1. The area served by the Metro System is referred to as the Metro Service Area.

1.2 Study Objective and Approach

The Cooperative Agreement sets forth the primary Study goal of maximizing reuse in the Metro Service Area in order to minimize flows to the Point Loma Wastewater Treatment Plant (Point Loma Plant). To achieve this goal, the Study develops and presents Integrated Reuse Alternatives that the public and policy makers can review and select from to guide the future of the Metropolitan Sewer System's service area reuse program. The central focus of the alternatives is non-potable and indirect potable reuse opportunities. Non-potable reuse is simply defined as recycled water generally used for irrigation and industry – not for drinking water. Indirect potable reuse is simply defined as the blending of advanced treated recycled water into a surface water reservoir or groundwater basin that could be used for drinking (potable) water after further treatment. The opportunities were evaluated to meet City, Participating Agency and project Stakeholder reuse goals through a 2035 planning horizon. The integrated reuse alternatives and the overall plan were based on two fundamental principles: 1) providing detailed non-potable recycled water and indirect potable reuse opportunities and 2) relating the opportunities to avoided cost benefits and water quality improvements. These considerations are described further in Chapter 3, Study Process and Evaluation Approach.

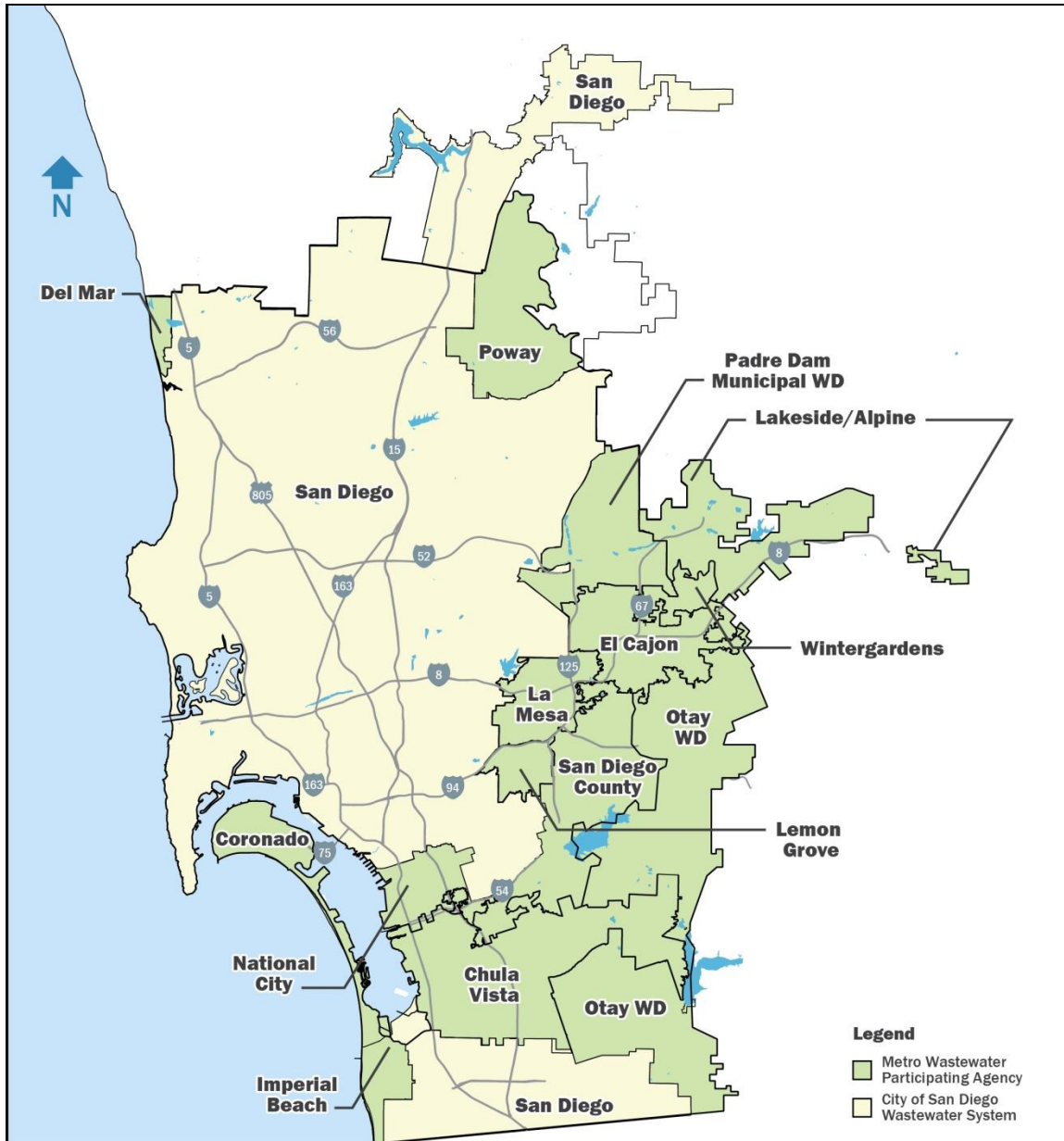

Figure 1-1. Metropolitan Sewerage System Service Area/Metro JPA Members
 Note: The San Diego County Sanitation District has recently consolidated and includes Winter Gardens, Lakeside, Alpine and Spring Valley (San Diego County) areas shown above.

1.3 Study Stakeholders

The Stakeholders for this Study are comprised of the San Diego Coastkeeper, the San Diego Chapter of the Surfrider Foundation, and the Participating Agencies of the Metro JPA, who have capacity rights in the Metro System pursuant to the provisions of the 1998 *Regional Wastewater Disposal Agreement Between the City of San Diego and the Participating Agencies in the Metro System*. San Diego County Water Authority (SDCWA), the agency that has primary responsibility for water supply planning efforts, and Independent Rates Oversight Committee (IROC), are also Study Stakeholders. SDCWA representatives provide regular updates on SDCWA activities related to the Study.

1.4 Study Process Overview

The Study includes a number of technical evaluations and coordination steps to identify and evaluate reuse alternatives within the City as well as areas served by the Participating Agencies. Throughout the Study, regular Stakeholder Status Update Meetings were held to present progress and to receive input and feedback on the activities. Eight technical memoranda (TM) were developed to document information. Figure 1-2 summarizes these activities, which have comprised this Study.

PROJECT STAKEHOLDERS

Environmental Groups

- San Diego Coastkeeper
- Surfrider Foundation, San Diego Chapter

Oversight Groups

- Independent Rates Oversight Committee (IROC)

Regional Water Supplies

- San Diego County Water Authority

Metro JPA Members

- City of Chula Vista
- City of Coronado
- City of Del Mar
- City of El Cajon
- City of Imperial Beach
- City of La Mesa
- City of National City
- City of Poway
- Lemon Grove Sanitation District
- Otay Water District
- Padre Dam Municipal Water District
- San Diego County Sanitation District
 - Alpine Sanitation District
 - Lakeside Sanitation District
 - Spring Valley Sanitation District
 - Winter Gardens Sewer Maintenance District

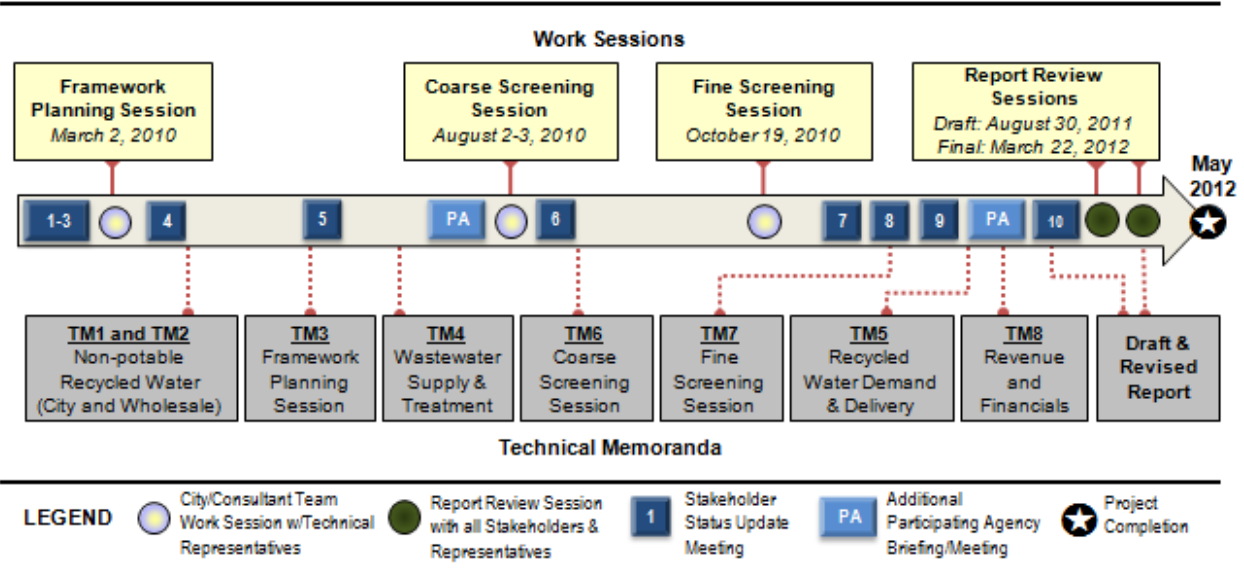

Figure 1-2. Study Process for the Recycled Water Study



1.5 Technical Memoranda Overview

The title and a brief description of each technical memorandum are provided below.

No. 1: Non-potable Reuse Market Assessment. Non-residential market assessments within the City limits are examined, including irrigation customers as well as cooling towers, car washes, and laundromats. Discussions on potential demands offered by individual Participating Agencies are included.

No. 2: Regional Non-potable Reuse Recycled Water Demand. Non-residential market demands within the Participating Agencies of the Metro System are assessed but limited to information received from them on questionnaires distributed by the Study Team.

No. 3: Framework Planning. A summary of the Framework Planning Session held to align the City, the consultant team, and Stakeholders on key project issues, processes, and future steps is provided.

No. 4: Wastewater Supply and Treatment. Discussion of projected recycled water supplies within the Metro System service area and examination of various treatment technologies is compiled.

No. 5: Recycled Water Demand and Delivery. An evaluation of the projected recycled water demand, the various options for delivery of recycled water, and the integrated reuse alternatives is presented.

No. 6: Coarse Screening. The Coarse Screening Session where project components were narrowed down is summarized.

No. 7: Fine Screening. The Fine Screening Session where final solutions and steps needed to move ahead were discussed is summarized.

No. 8: Financial Analysis of Recycled Water Project Alternatives. A cost evaluation of the proposed project components is presented.

1.6 Important Terminology Used in this Report

The following key terms used in this Study are defined in this introductory section due to their frequent use and their importance in understanding the concepts involved. The definitions for these terms are intended for audiences who may or may not be familiar with water reuse. Other definitions, including legislative definitions, can be found in the California Water Code. A more comprehensive glossary is included at the back of this Study.

Wastewater: Wastewater is generally used to describe sewage that comes from homes, industry or businesses. Wastewater is collected and treated at wastewater treatment plants. In San Diego, some wastewater is currently reclaimed as non-potable recycled water; however, the majority is treated and discharged to the ocean. Wastewater is needed for water reuse. Wastewater does not include stormwater in San Diego. Stormwater is collected in separate systems and typically not treated before discharge to streams and the ocean.

Water Reuse: Water reuse is a broad term used to describe the process of converting wastewater to a valuable water resource through treatment processes. Water reuse includes non-potable recycled water development and indirect potable reuse involving integration with drinking water supplies.

Non-potable Recycled Water: Synonymous with Non-potable Reclaimed Water, State of California Title 22 Water, and tertiary treated water. Non-potable recycled water is a form of water reuse that includes primary, secondary and tertiary treatment to produce water suitable for a variety of applications, most notably for landscaping irrigation and industrial uses. Further treatment is required for integration with drinking water systems – see indirect potable reuse.

Purified, Advanced Purified, or Advanced Treated Water: Purified, advanced purified, or advanced treated water undergoes advanced treatment processes to convert non-potable recycled water to a highly purified water quality, suitable for augmentation to an untreated drinking water source. Advanced purified water is currently used for indirect potable reuse projects.

Indirect Potable Reuse: Indirect potable reuse is the planned use of advanced purified water for replenishment of a groundwater basin or an aquifer that has been designated as a source of water supply for a public water system, or the planned placement of recycled water into a surface water reservoir used as a source of domestic drinking water supply.

Direct Potable Reuse: The planned introduction of advanced purified water either directly into a public water system, or into an untreated water supply, immediately upstream of a water treatment plant.

Uninterruptible Water Supply: Indirect potable reuse water is considered uninterruptible because it is not influenced by drought, water rights, or other supply interruptions such as the decision to decrease Southern California water supply because of endangered species in the California Bay-Delta.

Untreated Water (sometimes referred to as Raw Water): Water that is collected and stored in local surface water reservoirs and groundwater basins prior to treatment at a potable (drinking) water treatment plant. Untreated water examples include Colorado River water, water from the California Bay-Delta, and runoff from local rainfall.

Potable or Drinking Water: Potable water is water that meets the EPA's Safe Water Drinking Act and California Water Code requirements. Residents and businesses receive potable water at their water meter connection, and its use is unrestricted.

This page intentionally left blank.



2. WATER REUSE NEED AND RELATED ACTIVITIES

This is an important time for water and wastewater ratepayers in the San Diego area. The decisions to invest in water reuse programs or to fund large-scale wastewater system upgrades will affect the rates, reliability, and regional assets for decades. The fundamental focus of this Study was to develop water reuse alternatives – and then compare the alternatives with other options based on the water supply benefits created and the costs saved by avoiding other water and wastewater systems improvements (reference Chapter 8). The most relevant avoided cost involves the wastewater system and, in particular, the potential need to upgrade the Point Loma Plant to secondary treatment standards. This chapter outlines the considerations related to these issues and summarizes related reports and other activities pertinent to the reuse alternatives developed in this Study.

2.1 Water Supply and Water Reuse as a Local Supply Source

Water is important to the health, safety, and quality of life of people living in the San Diego region. The region has historically received a majority of its water supply from imported sources including the State Water Project (i.e. the Bay-Delta via the California Aqueduct) and the Colorado River Aqueduct. The Metropolitan Water District of Southern California (MWD) is responsible for managing the wholesale delivery of this water throughout Southern California. In San Diego, SDCWA is responsible for managing the distribution of imported water from the MWD and from the Imperial Irrigation Transfer Agreement to approximately 3.1 million residents (San Diego Association of Governments [SANDAG Series 12, 2010]). Currently, 80 percent of the San Diego region's water supply is imported. Local supplies and conservation account for the remaining 20 percent of the total supply.

The region's reliance on imported water makes the reliability of San Diego's water supply vulnerable to impacts from shortages and susceptible to price increases. In 2008, water supplied from the State Water Project was restricted to protect endangered fish species in the Bay-Delta. Drought conditions in Southern California further impacted water supply availability. With the region's population projected to increase to 3.9 million people in 2030 (SANDAG Series 12; 2030 Growth Forecast Update), demands will increase and strain these limited water supplies.

To address these dynamic water supply conditions, the San Diego region has been diversifying its supply portfolio to reduce reliance on imported water. Over the past two decades, this diversified portfolio approach has led to increases in local water supplies. Local water supplies include opportunities through increased water reuse, the recharge and recovery of groundwater, and the desalination of seawater (such as the Pendleton, Carlsbad and Rosarito concepts being evaluated). The City and surrounding communities have also committed to aggressive water conservation and water efficiency programs. The Recycled Water Study, as summarized in this Study, focuses on the Metro Service Area's water reuse potential and its ability to provide its residents with a sustainable, high-quality, local water supply.

2.2 Metro System Overview

The Metro System (described further in Chapter 3) is an important asset to the San Diego region. The last adopted Wastewater Master Plan was completed in 2003. The Wastewater Master Plan is currently being updated and a draft was prepared and distributed in September 2011. The Metro JPA will vote to adopt the revised plan. The focus of the wastewater planning efforts has been maintaining or lowering the total suspended solids discharged to the ocean per the 2010 NPDES permit (CA0107409). As part of the permit

conditions, the Point Loma Plant is limited to 15,000 metric tons per year for discharges through December 31, 2013 (see Appendix B for wastewater mass emission details and Appendix C, Section C.1.1, for further details on the permit). From January 1, 2014, however, the permit requires that the annual mass emission for total suspended solids be 13,598 metric tons or lower. Additional details on the permit and wastewater regulations are located in Appendix C.

The September 2011 Draft Wastewater Master Plan assumed that the Point Loma Plant would continue to operate as a CEPT plant and a series of large-scale projects would be built to divert solids and high flows away from it to prevent potential overflows during peak wet weather events. The diversion included redirecting the flow of wastewater from Point Loma to South Bay, adding a wastewater treatment plant in the Mission Valley area, expanding the North City Plant, and constructing a Point Loma Parallel Outfall to allow flows to bypass the Point Loma Plant and flow directly to the Point Loma Ocean Outfall. Although the September 2011 Draft Wastewater Master Plan would have expanded the Metro System's capacity to produce recycled water at new or expanded existing plants, it was not the primary objective. More importantly, the prospect of indirect potable reuse was not included in the September 2011 Draft Wastewater Master Plan. The cost of the September 2011 Draft Wastewater Master Plan improvements could be reduced by implementing water reuse projects to offload flows from the Point Loma Plant. In later chapters, the financial considerations associated with the reuse alternatives developed under the Recycled Water Study are compared to those included in the September 2011 Draft Wastewater Master Plan.

2.3 Key Studies and Activities

Several studies and activities provide an important basis for the work performed in this Study. The following summarizes these studies and activities and their relevance to this Report.

2.3.1 2005 Water Reuse Study

The City has long recognized the importance of developing a local water supply and has conducted several studies in an effort to create a system that provides that supply. In 2005, the City completed the Water Reuse Study which included a 35-member American Assembly panel comprised of a cross section of San Diego stakeholders. Public viewpoints were solicited through community meetings, focus groups, and telephone/online surveys. The Study included an evaluation of six strategies integrating non-potable reuse and indirect potable reuse opportunities for the North, Central, and South Service Areas. Option NC-3 was preferred by the Stakeholders, which included infilling non-potable demands served by the North City Water Reclamation Plant (North City Plant), followed by an indirect potable reuse project utilizing San Vicente Reservoir. For the South Bay, SB-1 (a non-potable approach serving a majority of non-potable water to the Otay Water District [Otay]) and SB-3 (an indirect potable reuse project utilizing Lower Otay Reservoir) were supported. This study was completed in conjunction with the *City of San Diego Recycled Water Master Plan Update 2005* (additional details on this study are included below).



The concluding American Assembly statement included:

“The Assembly unanimously agrees that current technology and scientific studies support the safe implementation of non-potable and indirect potable use projects. The Assembly considers advanced treated (purified) water to be superior in quality to other sources (e.g., Colorado River, State Project Water).”

“The Assembly believes that properly designed and operated advanced water treatment processes, coupled with a diligent and publicly accessible water quality monitoring program, produce water of exceptional quality that is protective of public health.”

“The Assembly believes that the costs of the strategies are affordable and equitable, and considers the strategies to be a necessary investment in our future.”

2.3.2 Water Purification Demonstration Project

The Water Purification Demonstration Project is the second phase of a process evaluating ways for the City to increase its use of recycled water (Figure 2-1). The first phase was the City's Water Reuse Study that identified reservoir augmentation as the preferred option for developing recycled water sources.

The Water Purification Demonstration Project will determine if reservoir augmentation is a feasible option for San Diego. The project will evaluate each step of reservoir augmentation, including:

- Using advanced water purification technology on highly treated wastewater.
- Sending the purified water to a reservoir to blend with existing water supplies.
- Treating the blended water again to be distributed as drinking water.



Figure 2-1. Water Purification Demonstration Project

The City's Water Purification Demonstration Project will demonstrate how one million gallons a day can be purified using technology that is able to produce one of the most pristine sources of water available anywhere.

2005 Independent Technical Panel Members

Chair: Richard Bull, Ph.D.
 Joseph A. Cotruvo, Ph.D.
 James Crook, Ph.D., P.E.
 Richard Gersberg, Ph.D.
 Christine L. Moe, Ph.D.
 James E.T. Moncur, Ph.D.
 Derek Patel, M.D.
 Joan B. Rose, Ph.D.
 Chair: George Tchobanoglous, Ph.D., P.E.,
 Professor
 Michael P. Wehner
 Fred Zuckerman

Current Water Purification Demonstration Project Independent Technical Panel Members

Chair: George Tchobanoglous, Ph.D., P.E.
 Michael A. Anderson, Ph.D.
 Richard J. Bull, Ph.D.
 Joseph A. Cotruvo, Ph.D.
 James Crook, Ph.D., P.E.
 Richard Gersberg, Ph.D.
 Sunny Jiang, Ph.D.
 Audrey D. Levine, Ph.D., P.E., DEE
 David R. Schubert, Ph.D.
 Michael P. Wehner

The Water Purification Demonstration Project is underway and will conclude in early 2013. During this time, the Advanced Water Purification Facility will operate at the North City Plant for approximately one year and will produce 1 million gallons per day (mgd) of purified water. Concurrently, a study of the San Vicente Reservoir is being conducted to test the key functions of reservoir augmentation and to determine the viability of a full-scale project. No purified water will be sent to the reservoir during the demonstration phase.

2.3.3 Independent Technical Panels

The City has engaged independent advisory technical review panels in 2005 (for the Water Reuse Study) and 2009 to present (for the Water Purification Demonstration Project). The City partnered with the National Water Research Institute to conduct the independent advisory panels. The panels focused on the health, safety, and viability of indirect potable reuse in the region. The 2005 panel agreed that indirect potable reuse/reservoir augmentation strategies presented the region with a unique opportunity to maximize the use of available capacity of the City's recycled water plants and provide safe

new water supplies. The 2009 panel is ongoing in support of the Water Purification Demonstration Project, with preliminary findings supporting the project approach.

2.3.4 2010 Recycled Water Master Plan Update

San Diego Municipal Code (Chapter 6, Article 4, Division 8) requires the City to prepare and adopt a Recycled Water Master Plan to define, encourage, and develop the use of recycled water within its boundaries. The Recycled Water Master Plan must be updated every five years. The last update was completed in 2005 (Recycled Water Master Plan Update 2005), necessitating the 2010 Recycled Water Master Plan Update (2010 Update). The purpose of the 2010 Update is to evaluate opportunities to maximize non-potable reuse if indirect potable reuse projects are not pursued (Figure 2-2). It describes the existing non-potable system and near-term expansions (through 2015), and identifies potential long-term non-potable reuse expansion concepts. Implementation of future non-potable reuse concepts beyond already planned expansions through 2015 relies on the results of the Demonstration Project and the viability of pursuing indirect potable reuse in San Diego.

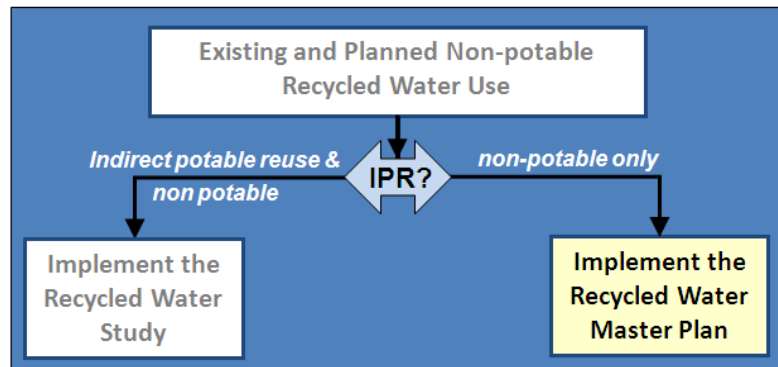

Figure 2-2. Recycled Water Master Plan Relationship to the Recycled Water Study

The Recycled Water Master Plan provides additional non-potable recycled water opportunities if indirect potable reuse is ultimately not pursued.

2.4 Other Studies and Information

The City and project Stakeholders have conducted numerous studies that provide information relevant to the development of this Study. The following is a listing of some of the studies either used in the technical analysis for this Study, or discussed in the Stakeholder meetings.

- **2015 Projections.** Non-potable Reuse Demand Forecast through year 2015.
- **2010 Water Facilities Master Plan.** Prioritized Water Facility Needs, 20-year Capital Improvement Project (CIP). The facility needs are determined based on operational and condition deficiencies.
- **2003 Metropolitan Wastewater Plan.** Wastewater Facility Needs. The Plan provides guidance for establishing a CIP program that is tied to flow projections and current permit conditions. The Plan also includes a list of projects that are driven by a condition assessment program that is currently conducted by the San Diego Public Utilities Department.
- **San Pasqual Conjunctive Study.** This study evaluates the ability of the San Pasqual Groundwater Basin to store water and withdraw at a later time.
- **Tijuana Basin Aquifer.** This study examines the feasibility of using the Tijuana Valley Alluvial Aquifer as a potential aquifer storage and recovery system to seasonally store recycled water.
- **Pilot Wells.** The pilot production well investigation evaluates the potential of ground water basins within the City's jurisdiction for water supply production potential for each basin for a new local water supply source.

- **2010 Urban Water Management Plan (UWMP).** In accordance with the California Urban Water Management Planning Act, all California agencies providing water to more than 3,000 customers or more than 3,000 acre-feet per year (AFY) of water are required to update their UWMP every five years and submit them to the Department of Water Resources. The UWMP looks at the City's historic and current water use projections and compares water supplies with demands over the next 20 years. The plan identifies the imported and local water supplies that will meet future demands including groundwater recovery and water recycling, as well as City's current and planned conservation measures. This helps to ensure that the City can provide a reliable supply of high-quality water to meet current and future demand. The Recycled Water Study used the same demand forecast as the UWMP. The UWMP may be accessed at the following web address: <http://www.sandiego.gov/water/pdf/uwmp2010.pdf>
- **Recycled Water Master Plan Update 2005.** The 2005 Recycled Water Master Plan was completed in parallel with the 2005 Water Reuse Study. This was the City's five-year update of their Recycled Water Master Plan to fulfill the requirements of San Diego Municipal Code. The study identified potential recycled water customers in both the northern and southern portions of the City, as well as potential new opportunities in the central portion of the City and in San Pasqual. The master plan included a market assessment and presented concepts to expand the City's recycled water distribution system. The 2005 Recycled Water Master Plan may be accessed at the following web address: <http://www.sandiego.gov/water/pdf/050927waterreuse.pdf>
- **Recycled Water Study Participating Agency Options.** This document was prepared by the Metro JPA Technical Advisory Committee (TAC) and provided to the City as draft on July 21, 2010. The document presented additional options to be considered as part of the Study. Options and ideas are presented to expand recycled water in the northern, eastern, and southern areas. The City provided a response letter to the Metro JPA TAC on August 17, 2010 to discuss how these options have been addressed or will be addressed in the Study. The Metro JPA TAC provided an updated version of these options in March 2011, retitled as *Regional Opportunities to Reduce Flows at Point Loma Plant* and again in September 2011, retitled as *Flow Reductions to Point Loma Wastewater Treatment Plant: Options Offered by the Participating Agencies*. This document is included in Appendix I.

This page intentionally left blank.



3. STUDY PROCESS AND EVALUATION APPROACH

3.1 Process

The Study was a two year, participatory process. The process included sequential steps to evaluate technical elements, present findings to the stakeholder group, refine the technical work based on stakeholder input, and present the findings in this Report. The key elements of the Study process are summarized in this chapter including the work sessions, the stakeholder integration, the approach to the technical work, and the criteria used on the evaluation process.

3.2 Work Session Summary

Five work sessions were held and attended by the City’s project team, the consultant team, and the Stakeholder’s independent technical advisor. The Participating Agencies sent representatives to the Coarse Screening Session, Fine Screening Session, and the Study Review Session. The work sessions were conducted at key milestones in the Study process. The format of the sessions included presentations on initial findings and on technical approaches. Group feedback was solicited throughout the presentations and through interactive group activities in which team members were asked to evaluate specific Study elements.

Framework Planning Session. The Framework Planning Session was the first session and was held to align the City, the consultant team and the Stakeholder group on key project issues and the evaluation process. The Framework Planning Session established the road map for the technical process and is summarized in Figure 3-1. The Framework Planning Session also confirmed the core criteria to be used for the water reuse alternatives developed.

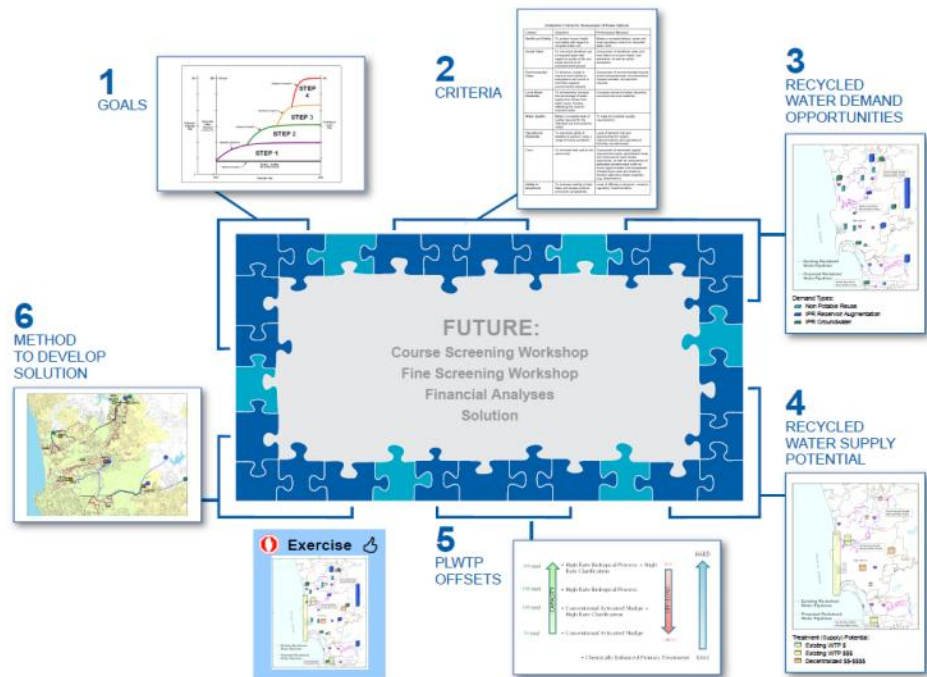

Figure 3-1. Framework Planning Session

The Framework Planning Session outlined the approach to complete the study.

Coarse Screening Session. The two-day Coarse Screening Session focused on the Area Concepts described in Chapter 8. Non-potable and indirect potable reuse opportunities throughout the region were evaluated. Participants were grouped in teams and tasked with developing water reuse alternatives to meet the Study objectives. The groups could also eliminate alternatives and recommend new alternatives.

Fine Screening Session. The Fine Screening Session was a one-day work session that focused on refining the Area Concepts (discussed at the Coarse Screening Session) into the final Integrated Reuse Alternatives (described in Chapter 9). The focus of the Fine Screening Session was for the participants to develop an understanding of the alternatives, to evaluate relative costs, to work as teams to assess whether the alternatives developed met the criteria developed in the Framework Planning Session, and to develop concept project implementation plans.

Study Review Session. The Study Review Session was a one-day work session held to discuss and refine the Study. Comments to the Study were solicited prior to the meeting and reviewed during the session.



Work Sessions. The Coarse Screening and Fine Screening Sessions included presentations, team exercises and facilitated discussions. The sessions leveraged the group's creativity and diverse perspectives to improve the quality of the alternatives presented in the Study.

3.3 Stakeholder Status Update Meetings

The Study included 10 Stakeholder Status Update Meetings scheduled throughout the Study process and aligned with important Study milestones. These meetings were attended by the City's team, the consultant team, and representatives from the Participating Agencies, San Diego Coastkeeper, the Surfrider Foundation, San Diego Chapter, the SDCWA, and the IROC. The update meetings lasted from two to three hours and were held at the City's Metro Operations Center 2 in Kearny Mesa, San Diego.

The Stakeholder Status Update Meetings played a vital role in the Study, providing Stakeholders the opportunity to participate and comment on Study efforts. Each Stakeholder played an important role and provided a diverse viewpoint on the future of water recycling in the region. The Stakeholders asked critical questions and provided alternative concepts that added value to the alternatives discussion. When a new concept or approach was proposed, the project team tested the new ideas against the Study goals and objectives (described further below). If the concepts met these goals and objectives, the alternative was considered further in the Study.

3.4 Adaptive Model

To fully evaluate the range of ideas put forward during the work sessions and update meetings, an adaptive model was developed. The adaptive model is a series of spreadsheets, summarized in Figure 3-2, which integrated key technical information and calculations to provide sizing and costs for different water reuse alternatives. The model also summarized sequencing, capital, and operational costs (energy, chemicals, labor) and available flows. It is important to note that the adaptive model is a tool designed to quickly ascertain the impact of changing conditions on the overall planned system and the associated costs.

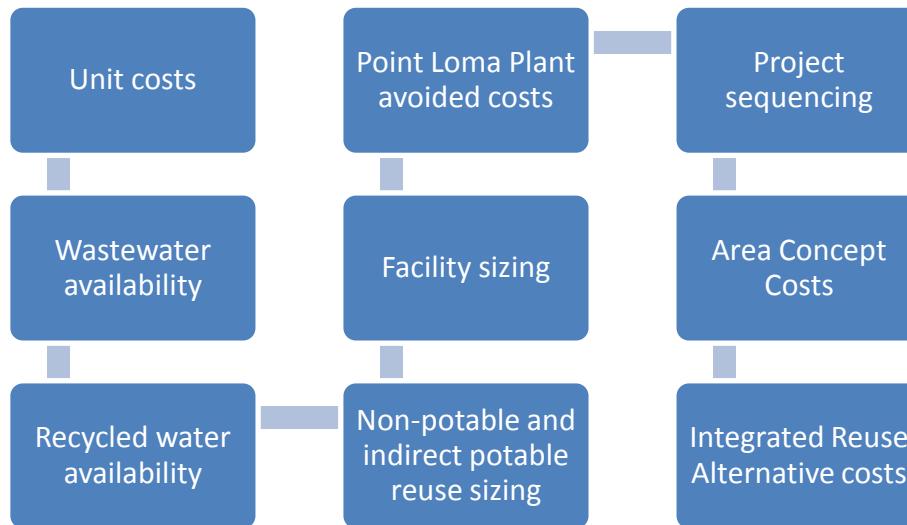

Figure 3-2. Adaptive Model

The adaptive model played an important role during the working sessions in highlighting the project sequencing options and capital and operational and maintenance costs.

3.4.1 Guidelines for what Opportunities were Considered

Achieving the goals for this Study required developing non-potable recycled water and indirect potable reuse opportunities. Multiple methods and project approaches are available to achieve this. The following guidelines were developed to provide the level of detail needed for an opportunity to be considered in this Study. These guidelines were applied to projects developed by the Study Team and opportunities provided by participants at the Stakeholder update meetings and the Coarse and Fine Screening Sessions.

1. **Provide Detailed Opportunities.** Projects (especially the early phase projects) should have enough technical information to determine if they are feasible and safe and provide a valuable local water resource. Projects should be developed based on a consistent approach and be defined to the point that comparative costs and benefits can be developed.
2. **Relate opportunities to water supply benefits, avoided cost savings, and water quality improvements.** The opportunities should address the water and wastewater system benefits created from water reuse projects, particularly through avoided costs savings at the Point Loma Plant. This includes the environmental community's goal of reducing ocean discharges by creating new high quality water reuse opportunities. The plan should also meet the City's and Participating Agencies' goal of managing Metro System costs and their impacts to ratepayers.

A process was developed to meet the key considerations above. Each alternative considered in this process received extensive technical evaluation, stakeholder scrutiny, and refinement. Key components of the process included:

Provide thorough technical evaluations:

- Account for capital and operation and maintenance costs, including an evaluation of pumping needs.
- Balance opportunities and constraints, particularly in relation to the dynamic regulatory permitting environment.
- Apply non-cost criteria to determine other benefits or considerations important in decision making.

Provide larger-scale projects that are more cost effective (i.e. they provide economies of scale):

- Maximize the City's and Participating Agencies' investments in existing infrastructure.
- Identify water and wastewater cost savings by avoiding or deferring system improvements. Focus opportunities to divert wastewater where larger quantities are available.
- Prioritize projects that provide the most water benefit at the least cost (noting that other non-cost criteria must be addressed).

Develop solutions that promote diverse stakeholder goals:

- Recognize the environmental groups' desire to reduce discharges to the ocean from the Point Loma Plant.
- Recognize the City and Participating Agencies' desire to maximize investments through new water reuse opportunities, while minimizing ratepayer impacts from wastewater system costs and upgrades at the Point Loma Plant.

3.5 Criteria Used to Assess Water Reuse Alternatives

One of the preliminary tasks of the Study was to determine the appropriate criteria to use in evaluating potential water reuse alternatives. During the Framework Planning Session, the 2005 Water Reuse Study criteria were presented and compared to the criteria being used in the City's current master planning process. It was determined that the 2005 criteria are applicable to this Study and would be used since they were previously vetted by an in-depth stakeholder process and are directly applicable to water reuse decision making. Each alternative was evaluated on a pass-fail basis against the qualitative criteria and then screened and prioritized based on the quantitative criteria (such as cost). Eight criteria categories were identified for application to the integrated reuse solutions. Table 3-1 summarizes the criteria.

Table 3-1. Evaluation Criteria		
No.	Criteria	Objective
1	Health and Safety	To protect human health and safety with regard to recycled water use and wastewater
2	Social Value	To maximize beneficial use of recycled water with regard to quality of life and equal service to all socioeconomic groups
3	Environmental Value	To enhance, create, or improve local habitat or ecosystems and avoid or minimize negative environmental impacts
4	Local Water Reliability	To substantially increase the percentage of water supply that comes from water reuse, thereby offsetting the need for imported water
5	Water Quality	To meet or exceed level of quality required for the intended use and customer needs
6	Operational Reliability	To maximize ability of facilities to perform under a range of future conditions
7	Cost	To minimize total cost to the community
8	Ability to Implement	To evaluate viability or fatal flaws and assess political and public acceptability

This page intentionally left blank.



4. KEY FACILITIES, WATER DEMANDS, AND WASTEWATER FLOWS

The reuse alternatives developed in this Study required evaluating certain elements of the region's water, wastewater, and recycled water infrastructure and their related demands and flows. Early in the Study, this information was developed as the foundation for preparing the integrated reuse alternatives presented later in this Report. The following summarizes the key tasks, with additional background provided in the remaining sections of this Chapter.

- **Potable (Drinking) Water Demands.** Determine the projected quantity of water to be produced at water treatment plants to meet the demands within the service area and evaluate ways to integrate reuse alternatives into the picture.
- **Potable (Drinking) Water System Infrastructure.** Identify conveyance facilities (pipelines and pump stations) that may play a role in non-potable recycled water projects or indirect potable reuse projects and identify drinking water treatment plant locations that may play a role in an indirect potable reuse project.
- **Non-potable Recycled Water Facilities.** Assess the existing infrastructure, opportunities for improvements, and/or additions to the existing recycled water system, including treatment and distribution infrastructure, to meet future needs.
- **Non-potable Recycled Water Demands.** Determine the remaining amount of tertiary treated water available for further treatment and recycling after existing and planned non-potable recycled water demands have been met.
- **Wastewater Facilities.** Identify planned facilities upgrades (primarily but not limited to the Point Loma Plant) that could be avoided by expanding reuse throughout the region.
- **Wastewater Flows.** Estimate how much wastewater is available nearby for producing recycled water, and summarize the locations where this resource is located.

4.1 Potable Water System and Demands

The San Diego region has infrastructure that conveys water from various supply sources to storage and treatment facilities. Water conveyance infrastructure relevant to the reuse alternatives developed in this Study, including local reservoirs, groundwater basins, SDCWA aqueduct supply pipelines and key supply pipelines, is shown on Figure 4-1. The City's three potable (drinking) water plants (Alvarado, Miramar, and Otay) were evaluated early in this Study related to their long term demands and their ability to integrate with indirect potable reuse projects.

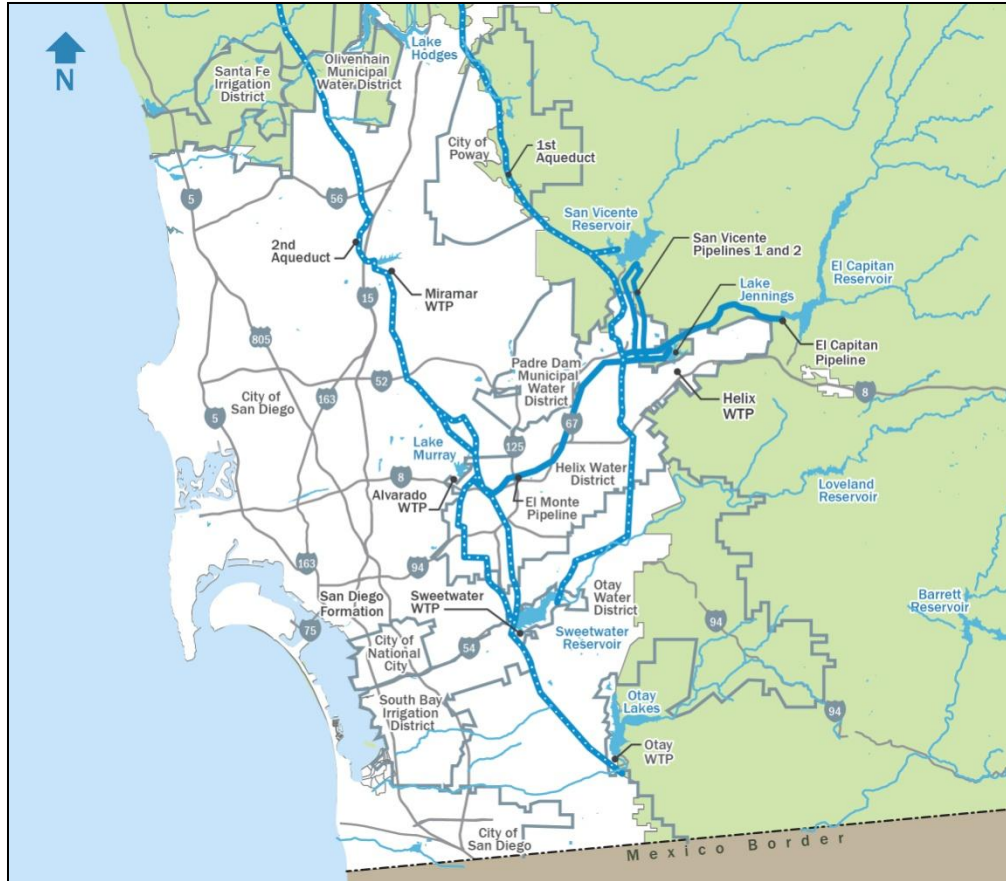

Figure 4-1. Regional Water Infrastructure Related to the Reuse Alternatives in the Study

4.2 Recycled Water System and Demands

The following summarizes the City's existing recycled water system and two additional reclamation plants that impact flows at the Point Loma Plant. The City's 2010 Recycled Water Master Plan Update includes additional details on the City's existing non-potable recycled water system.

4.2.1 Water Reclamation Plants

The City of San Diego operates two water reclamation plants as part of the Metro System. The North City Water Reclamation Plant (North City Plant) and the South Bay Water Reclamation Plant (South Bay Plant) produce non-potable recycled water for irrigation and industrial uses and divert flows away from the Point Loma Plant. Two additional reclamation plants (each separately owned and operated by one of Participating Agencies and separate from the Metro System) also offload flows before reaching the Metro System. The conveyance of non-potable recycled water from the reclamation plants to customers (via pumps, piping and reservoirs) is coordinated by individual water purveyors and is not part of the Metro System.

4.2.1.1 North City Water Reclamation Plant

The North City Plant was commissioned in 1997. It treats wastewater generated in portions of the northern San Diego region, which includes the cities of Del Mar and Poway, and the City's Mira Mesa, Rancho Penasquitos, Scripps Ranch, and Rancho Bernardo communities. The North City Plant treatment processes are summarized on Figure 4-2. After undergoing tertiary treatment and disinfection, the non-potable recycled water is distributed to surrounding communities for irrigation and industrial uses. Solids removed during the treatment process are pumped approximately five miles to the Metropolitan Biosolids Center for treatment. Wastewater in excess of the non-potable recycled water demands is treated to secondary level and diverted to the Metro System into the Rose Canyon Trunk Sewer and ultimately flows to the Point Loma Plant. The current North City Plant design capacity is 30 mgd (based on an annual average daily inflow rate); however, it was master planned for expansion to 45 mgd.

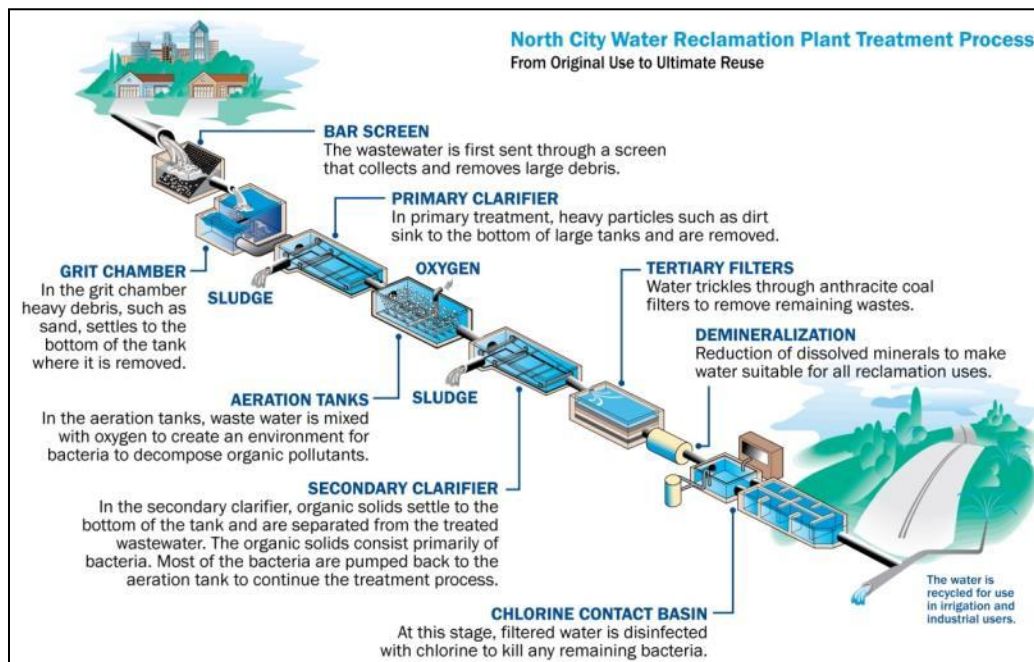

Figure 4-2. North City Water Reclamation Plant Treatment Process Schematic

Historical non-potable recycled water demands served by the North City Plant are shown in Figure 4-3. Three trends can be seen in the North City Plant output. From 1998 to 2004, demands remained fairly constant as the system was expanded. Steadily increasing demands occurred from 2004 through 2008 as the first phase of the 2000 Beneficial Reuse Study improvements were implemented and the City added new infill customers. From 2009 through 2010, a downward trend in demands persisted, even though new users were added to the system. The reduction is attributed to conservation, water efficiency, and the economic downturn.

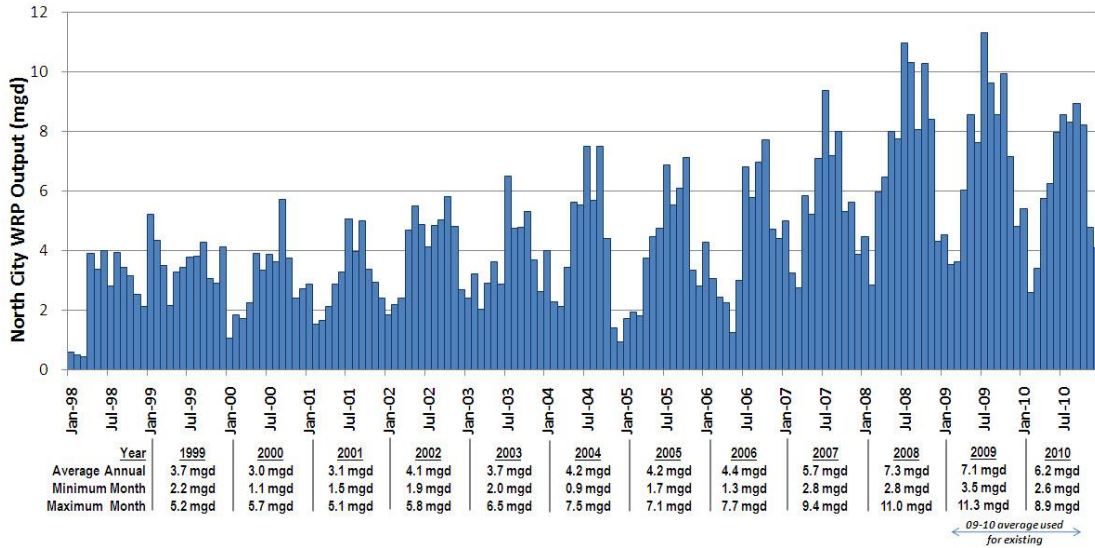

Figure 4-3. North City Water Reclamation Plant Non-potable Recycled Water Output

North City Plant output increased from 2002 through 2008. Lower demands in 2009 and 2010 occurred even though new customers were connected to the system. Conservation, water efficiency, and the poor economic climate were factors that affected usage. Future usage may continue to be affected by these conditions, or new influencers (such as changes to the recycled water rate).



4.2.1.2 South Bay Plant

The South Bay Plant was commissioned in 2002. The plant serves areas close to the South Bay Plant and the Otay Water District (Otay). The facility has a capacity to treat up to 15 mgd (based on an annual average daily inflow rate) and is located in the Tijuana River Valley near the international border. The treatment processes are shown on Figure 4-4. The tertiary facilities, which allow production of non-potable recycled water, were certified in 2004. Normal operations began in 2006 after the International Boundary and Water Commission Plant became operational as the first major customer. Tertiary treated water is distributed to surrounding areas for non-potable recycled water uses. Wastewater in excess of the non-potable reuse demands is treated to secondary level and discharged to the ocean via the 3.5-mile-long South Bay Ocean Outfall. Solids removed at the South Bay Plant are returned to the collection system for transport to the Point Loma Plant for treatment.

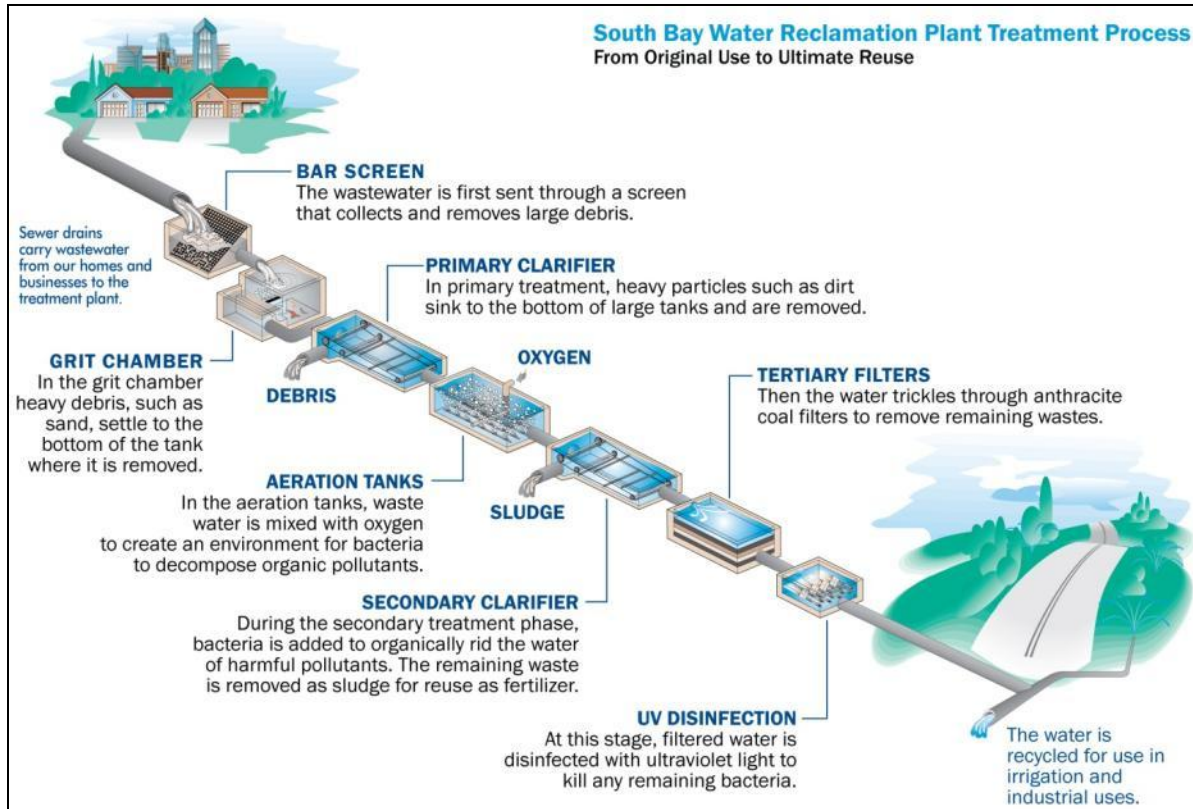

Figure 4-4. South Bay Plant Treatment Process Schematic

Historical non-potable recycled water demands served by the South Bay Plant are shown on Figure 4-5. Similar to the North City Plant, the South Bay Plant has experienced lower demands for the past two years. A majority of the South Bay demands are served to Otay through a wholesale agreement with the City. Otay has developed an extensive non-potable recycled water system, which is supplied from both the South Bay Plant and Otay's Ralph W. Chapman Recycled Water Facility (Chapman Plant).

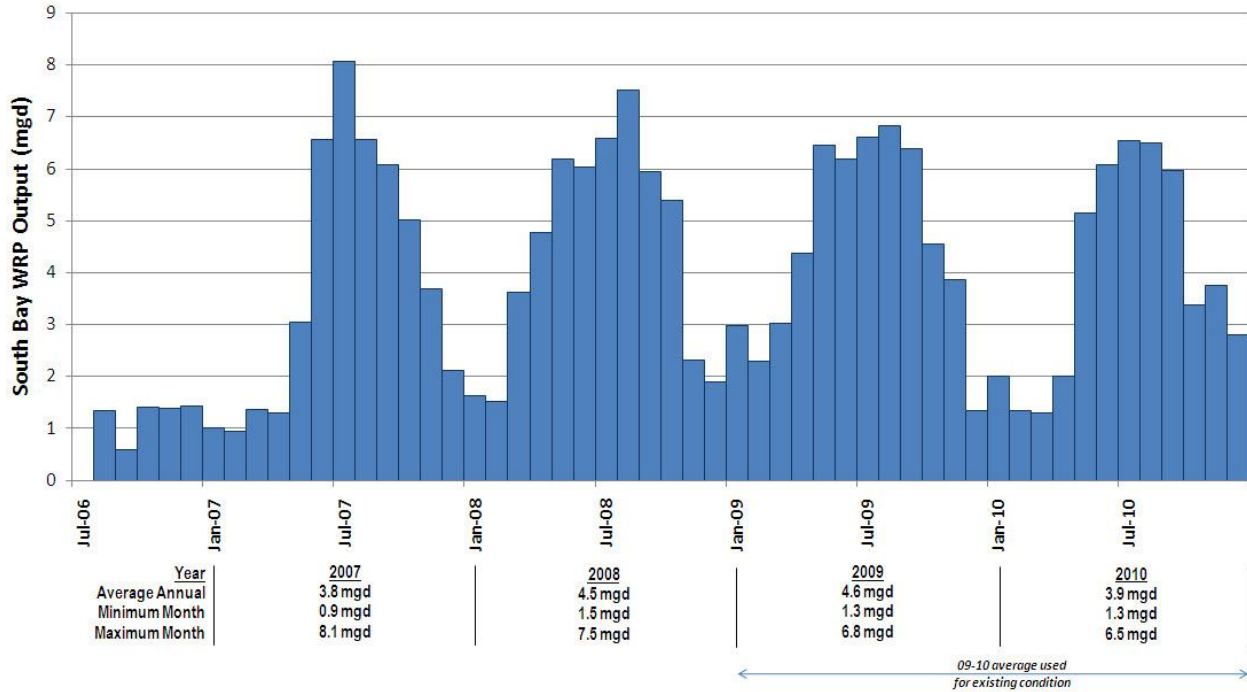

Figure 4-5. South Bay Plant Non-potable Recycled Water Output

Similar to the North City Plant, the South Bay Plant has had decreases in plant output due to reduced demands. Demands in South Bay are projected to increase as new customers are brought online, particularly in Otay’s service area.

4.2.1.3 Padre Dam Water Recycling Facility

The Padre Dam Municipal Water District (Padre Dam) has been a leader in water reuse – from its innovative Santee Lakes to a non-potable system encompassing the 2.0 mgd Padre Dam Water Reclamation Facility. The Padre Dam Water Recycling Facility is located in Santee. Wastewater from the City of Santee, portions of the City of El Cajon, and the unincorporated community of Lakeside is diverted to the treatment facility to allow reuse (in lieu of flowing to the Metro System and the Point Loma Plant).



The Padre Dam Water Recycling Facility serves non-potable recycled water demands in Santee through a dedicated distribution system. In 2010 this system delivered 739 AF to landscape irrigation and 15 AF for construction purposes (Table 20 of the 2010 Urban Water Management Plan for Padre Dam). Also in 2010, 1,120 AF of treated water not used for irrigation is discharged to the Santee Lakes, a series of seven constructed lakes owned and operated by Padre Dam. Water enters the first lake and flows by gravity through each lake until it eventually reaches Sycamore Creek, a tributary of the San Diego River. Sycamore Creek flows through decorative ponds within the Carlton Oaks Country Club golf course for approximately one mile before entering the San Diego River. Wastes are sent back to the Metro System for treatment downstream at the Point Loma Plant.

Padre Dam, in conjunction with the Helix Water District, is also evaluating the ability to expand the plant as part of an indirect potable reuse project in El Monte Valley. The 5 mgd El Monte Groundwater Recharge Project would provide a valuable new water source for the region. Its flows and timing were considered in this Study. Padre Dam is also working with the Bureau of Reclamation to evaluate the potential for groundwater recharge in the Santee basin. The elements of this evaluation were not considered in this Study.

4.2.1.4 Ralph W. Chapman Water Recycling Facility



Otay has emphasized the importance of recycled water in San Diego and has one of the largest distribution systems in the region. In 1980, Otay began operation of the Chapman Plant. This facility is located near Rancho San Diego and produces approximately 1.1 mgd of recycled water. Waste from the treatment process is discharged to the sewer for treatment at Point Loma Plant. Recycled water is used for irrigation in Eastlake, Otay Ranch, Rancho Del Rey, and other areas of Chula Vista. Otay has also considered expanding this plant ultimately to 3.9 mgd.

4.2.2 Recycled Water Conveyance System

The City operates a non-potable recycled water system comprised of two service areas – the Northern Service Area and the Southern Service Area. The Northern Service Area is supplied with recycled water from the North City Plant. As of 2010, the Northern Service Area consists of 83 miles of pipeline within San Diego, distributing recycled water to retail customers in the City and two wholesale customers: the City of Poway and the Olivenhain Municipal Water District. Figure 4-6 displays the recycled water conveyance system, which includes 526 retail water meters as of fiscal year 2011. Approximately 99 percent of the retail and wholesale customers use the water for irrigation, while the remaining customers use the water for cooling towers, construction, ornamental fountains and toilet/urinal flushing. The Southern Service Area is supplied non-potable recycled water by the South Bay Plant. The conveyance system is relatively simple and includes 3.12 miles of pipeline that distributes recycled water to the City’s retail customers and Otay, a wholesale customer.

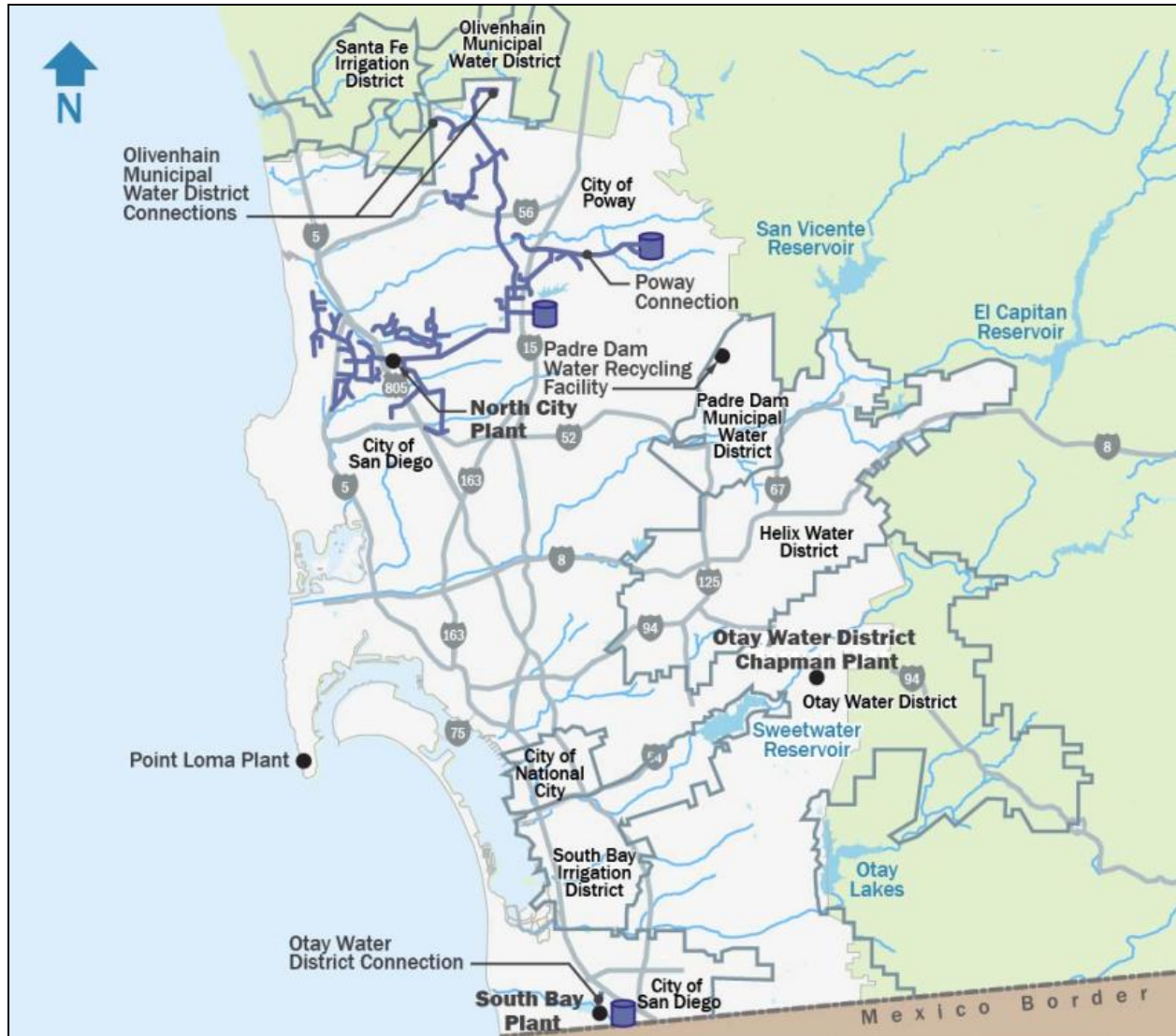

Figure 4-6. Non-potable Recycled Water Conveyance System

Shown above is the City's non-potable recycled water system. Also shown are the recycled water treatment plants in the Metro Service Area. Both Padre Dam and Otay operate their own non-potable recycled water distribution systems.

4.3 Wastewater System

The Metro System is the largest wastewater system in San Diego County. The system is managed by the City and Participating Agencies and serves a 450-square-mile area that includes incorporated areas of the City and 15 cities and districts. The Metro System includes conveyance facilities (pipelines and pump stations), wastewater treatment plants, two ocean outfalls, water reclamation plants, and a regional biosolids processing facility. Figure 4-7 presents a schematic of the Metro System showing the major facilities. The two largest pump stations in the Metro System are Pump Station No. 1 (PS1), located at the City of San Diego and National City border on Harbor Drive, and Pump Station No. 2 (PS2), located along Harbor Drive and adjacent to the San Diego International Airport. PS1 collects wastewater from the southern portion of the Metro System service area and pumps it northward to PS2 via the South Metro Interceptor. PS2 pumps wastewater collected from the Metro System to the Point Loma Plant via two 87-inch force mains and a

96-inch West Point Loma Interceptor. PS1 and PS2 are key locations related to wastewater flows, as described further below.

Current plans to maintain and improve the Metro System include a series of projects requiring significant capital investments in the coming years. In addition, the ability to maintain the Point Loma Plant without secondary treatment facilities continues to be debated and may not be allowed in the future, which would add further costs. Therefore, it is important to determine whether any of these expensive wastewater system upgrades could be avoided through new reuse approaches. The region’s ratepayers can often times be better served by investing in sustainable water reuse systems as opposed to wastewater disposal systems.

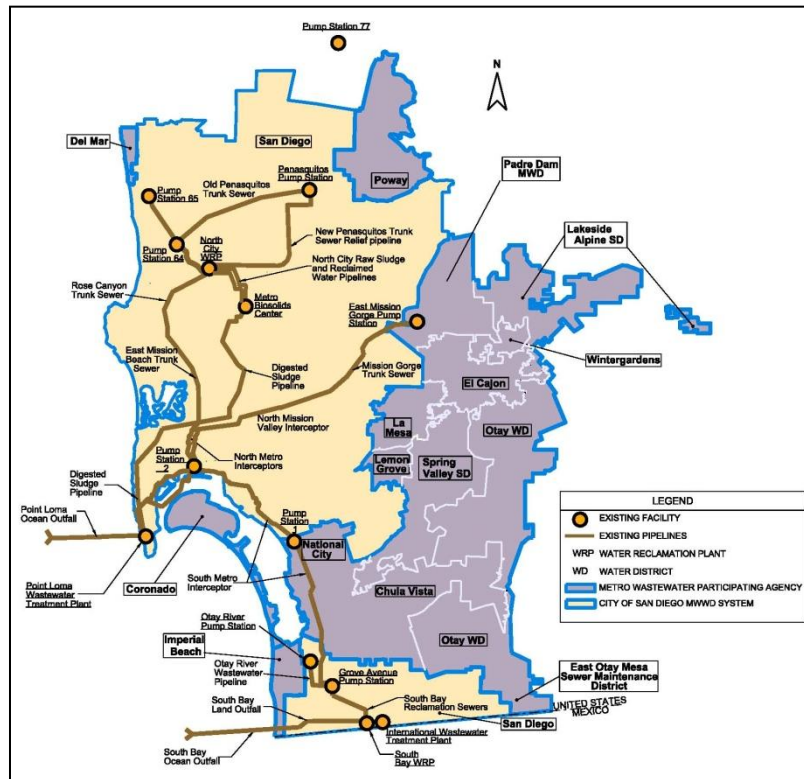

Figure 4-7. Metropolitan Sewerage System

4.3.1 Point Loma Plant



The Point Loma Plant is a chemically enhanced primary treatment facility located on the south and westerly coastline of the Point Loma Peninsula. It has a rated capacity of 240 mgd based on annual average daily flows and a peak wet weather capacity of 432 mgd. The plant is bounded by the Pacific Ocean to the west, the United States Navy Base to the north, Cabrillo National Monument to the south, and Fort Rosecrans National Cemetery to the east. Furthermore, a steep hillside runs adjacent to the plant’s east perimeter. The Point Loma Plant processes are summarized in Figure 4-8 and include eight anaerobic digesters that stabilize the primary solids before pumping 17 miles to the Metropolitan Biosolids Center. Treated wastewater is discharged from the plant to the Pacific Ocean via the 4.5-mile-long Point Loma Ocean Outfall.

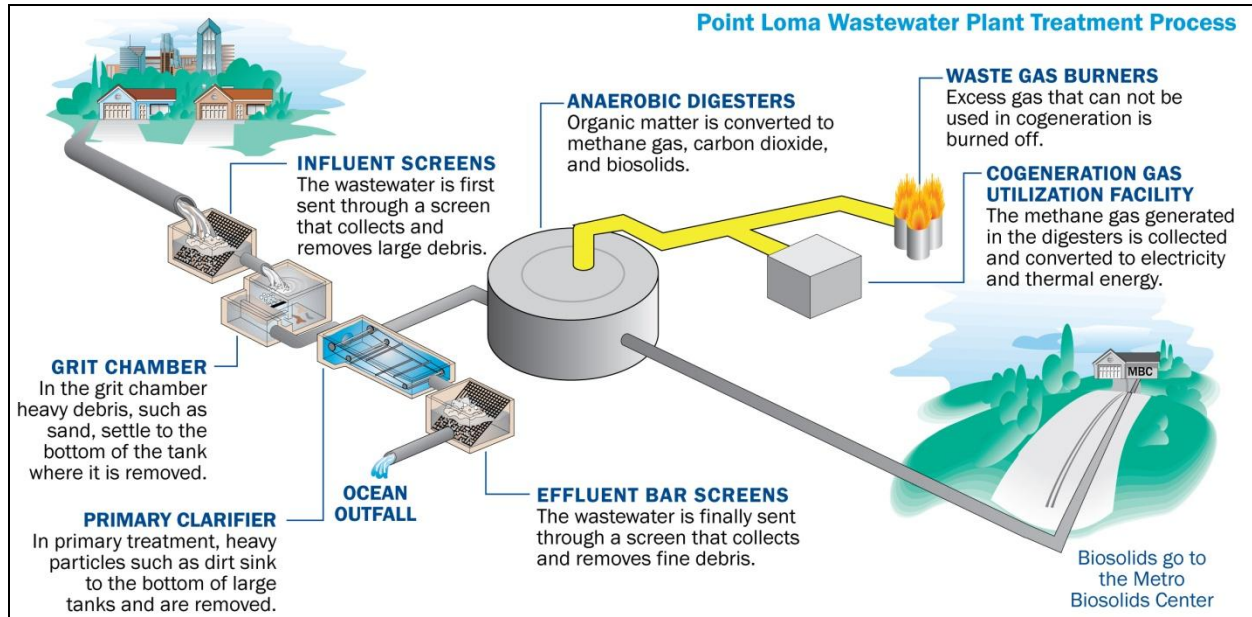

Figure 4-8. Point Loma Plant Process Schematic

4.3.2 Metropolitan Biosolids Center

The Metropolitan Biosolids Center (referred to as MBC) is a Metro System biosolids treatment facility located adjacent to the Miramar Landfill. MBC receives waste from the Point Loma Plant and the North City Plant. Wastes from the North City Plant are pumped to MBC, where it is thickened and digested. A separate pipeline conveys digested biosolids from the Point Loma Plant to MBC. Water from the mixture of digested biosolids from the North City Plant and the Point Loma Plant are removed using a centrifuge. The dewatered biosolids are then hauled away for land application or landfill cover. The MBC was commissioned in 1998 and is currently sized to treat 179 dry tons per day (a dry ton is 2000 pounds of sludge that is devoid of water).



4.4 Wastewater Flows

The City monitors influent and effluent flow from all of their treatment plants as required per NPDES permits and to aid in the operation of plant processes. In addition, flows are monitored at locations where Participating Agencies connect to the Metro System to facilitate the City's billing. Historic flow data can be used to help detect long-term trends and the effects of large-scale events (e.g., storms, recessions, growth due to construction, etc.). The data also helps project future flows that may identify potential capacity shortfalls. Below is a summary of historic flows at the City's treatment facilities.

4.4.1 Point Loma Plant Influent Flows

Point Loma Plant flows from January 2003 through June 2011 are shown on Figure 4-9. The Point Loma Plant consistently received about 170 mgd of annual average daily flows from 2003 to 2004. In 2005, a significant above-average rainfall season triggered higher flow rates of rainfall-dependent inflows and infiltration and groundwater infiltration in the sewer system. During this time, a 185-mgd annual average daily flow was recorded at the Point Loma Plant. The flow gradually receded to the 2003/04 levels of 170 mgd in

2006. Then, over the next four and a half years, flows steadily decreased to approximately 145 mgd by August of 2009. In this timeframe, the North City Plant and the South Bay Plant increased non-potable recycled water production, which reduced flows to the Point Loma Plant. The North City Plant increased recycled water production from 3.5 mgd to 4.5 mgd, while the South Bay Plant increased recycled water production from 4.6 mgd to 8.6 mgd. In addition, decreased rainfall from April 2006 to August 2009 lowered the groundwater table, thus reducing flows attributed to groundwater infiltration. The drought and higher water rates also spurred significant water conservation and water efficiency measures. The combination of these factors contributed to the decreased flow observed at the Point Loma Plant between August 2006 and August 2009. In 2010, the average influent flow increased to 156 mgd due to above average rainfall events.

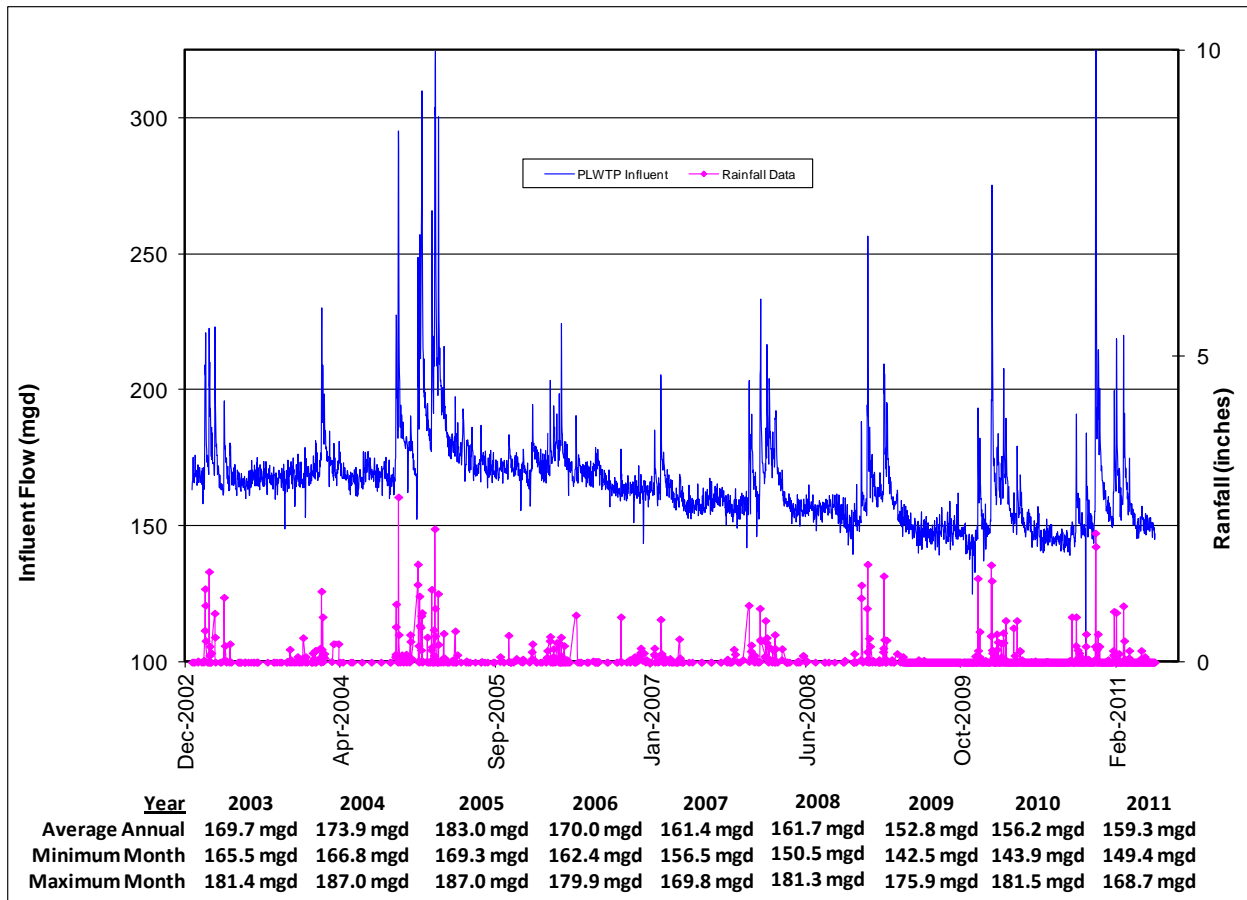

Figure 4-9. Point Loma Plant Daily Average Influent Flow and Rainfall Data for 2003 to 2011

Note: 2011 flows include values from January through June only.

4.4.2 Wastewater Flow Scenarios and Application in this Study

The following wastewater flow scenarios were used in this Study. A projected dry weather flow was used to estimate the wastewater availability for producing the recycled water on a typical dry year. A projected 10-year return event wet weather flow scenario was used to size the Point Loma and South Bay facilities based on the City’s September 2011 Draft Wastewater Master Plan. The following summarizes these conditions.

Dry Weather Flow (DWF). The DWF condition used is based on 2035 wastewater flow projections and represents the amount of wastewater generated over one year without any consideration of the wet weather



component (infiltration and inflow). This flow condition was used to size recycling facilities that are upstream of the Point Loma Wastewater Treatment Plant and that have no outfall.

Wet Weather Flows. The Metro System is designed to handle wet weather events based on criteria developed by the City and approved by the Metro JPA members. The September 2011 Draft Wastewater Master Plan includes a series of projects to handle the wet weather condition based on flows through 2050. Two 2050 flow conditions were used to provide a direct comparison between the Wastewater Master Plan and this Study, strictly for the purposes of determining direct and indirect wastewater system savings generated by the reuse projects in this Study (see Chapter 8). The flow conditions are described as follows:

- **10-year Return Annual Average Daily Flow (AADF).** The 10-year return AADF condition used in this Study is based on 2050 wastewater flow projections and represents the amount of wastewater generated over one year and contains a wet weather component based on a 10-year return period.
- **10-year Return Peak Wet Weather Flow (PWWF).** The 10-year return PWWF condition used in this Study is based on 2050 wastewater flow projections and is determined by applying a peaking factor to the 10-year return AADF to obtain the peak daily flow occurring during the 10-year return event (i.e., AADF is the annual average flow including the wet weather return period and PWWF is the peak daily flow during the return event). This flow condition applies to the strategy and design of the Point Loma and South Bay Plants to handle a peak wet weather event.

Table 4-2 below summarizes Metro System flows for different conditions, and which condition was used for sizing and capacity analyses.

Location	2035 Dry Weather Flows: Basis for Sizing Reuse Projects	2050 Point Loma and South Bay Sizing	
		Annual Average Daily Flow w/10-year Return Event	Peak Wet Weather Flow w/10-year Return Event
South Bay Plant	44 mgd	65 mgd	151 mgd
North City Plant	29 to 45 mgd	N/A	N/A
Harbor Drive	55 mgd to 72 mgd	N/A	N/A
Mission Gorge	0 mgd to 9 mgd	N/A	N/A
Point Loma Plant	79 mgd	143 mgd	320 mgd

Notes:

- 2050 Flows shown are based on the reuse projects included in this Study and were compared to the City's September 2011 Draft Wastewater Master Plan 2050 flows (see Chapter 8 and Appendix H).
- SV8 Diversion will be sized for a 47 mgd AADF and a 133 mgd PWWF in coordination with City's September 2011 Draft Wastewater Master Plan.
- Grove Avenue Pump Station (GAPS) will convey 18 mgd during annual average daily demands and peak wet weather events. Remaining flows enter the South Metro Interceptor and can be diverted back to the South Bay Plant via the planned SV8 Diversion.
- North City, Harbor Drive and Mission Gorge ranges dependent upon which Alternative is selected (see Chapter 8).
- 28 MG storage assumed to equalize PWWF to the Point Loma Plant.
- 2035 Point Loma Plant DWF assumes 9 mgd of non-potable recycled water is produced at the North City Plant and 3 mgd is produced at the Padre Dam Plant.
- 5 mgd of IPR from the El Monte Groundwater Recharge or other equivalent project included.
- 68 mgd of IPR delivered to the San Vicente Reservoir included.

4.4.3 North City Plant Influent Flows

The North City Plant receives influent directly from the Penasquitos Pump Station (PS) and a portion of the flow in the New Rose Canyon Trunk Sewer, which conveys the Pump Station 64 (PS64) discharge. Currently, 7 mgd is diverted from the Penasquitos Pump Station, and approximately 10 mgd is diverted from the new Rose Canyon Trunk Sewer. The resulting influent flow at the North City Plant is approximately 17 mgd. All

flows are treated to secondary levels. A portion of the flows (only the amount needed for the non-potable recycled water system) are treated to tertiary levels. Excess secondary treated flows not used in the non-potable recycled water system are returned to the Metro System. North City influent flows are anticipated to reach 28.8 mgd in 2035.

4.4.4 South Bay Plant Influent Flows

In 2002, the South Bay Plant began treating approximately 4.6 mgd of wastewater from the South Bay area, conveyed to the plant via the Grove Avenue Pump Station. In the summer of 2006, the plant began increasing the amount of wastewater treated by approximately 4 mgd to a total of 8.6 mgd. The increase was needed to meet the increased recycled water demand from Otay, which had just completed an extension of their recycled water distribution system. Dry Weather Flows to the South Bay Plant are projected to be 12.9 mgd by 2035 and 15 mgd (reaching the existing Plant capacity) by 2050 (unless a new diversion is constructed to divert wastewater from the Point Loma Plant to the South Bay Plant). The Study included evaluating new wastewater diversions to the South Bay Plant at the Study's 2035 planning horizon. The City and Otay are also separately discussing interim diversions to meet peak summer day demands.

4.4.5 Wastewater Flows and Losses through Treatment Processes

Each year the City prepares a Flow and Strength Report that reviews historic wastewater flows and prepares projections to support the Public Utilities Department's financial planning. These projections are important to this Study since the quantity, location, and quality of the available wastewater are key considerations in developing reuse alternatives. Updated projections for flow and load calculations were developed using San Diego Association of Governments (SANDAG) population forecast. This information was compiled with additional data and technical analysis to provide flow projections as summarized on Figure 4-10.

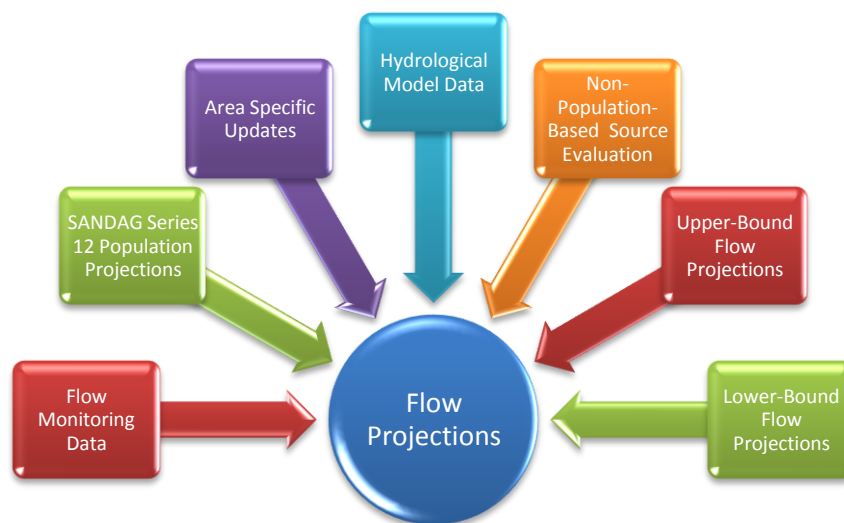

Figure 4-10. Elements that Make Up the Flow Projections

Table 4-3 summarizes the wastewater available at existing and 2035 conditions at various locations in the Metro System. These totals were important in evaluating how much wastewater could be diverted to existing water reclamation plants and whether new treatment plants could be located at these locations where the wastewater was available. Figures 4-11 and 4-12 illustrate the relative locations of the major sewer lines indicated in Table 4-3.

Table 4-3. Projected Dry Weather Flows at Specified Locations in the Metro System

Site No.	Sewer Line	Dry Weather Flows (mgd)						
		2010	2015	2020	2025	2030	2035	
N1	Pump Station 64 Force Main	18.0	18.1	18.2	19.2	19.6	20.1	Tributary to the North City Plant
N2	Penasquitos Pump Station Force Main	7.8	8.1	8.5	8.6	8.6	8.7	
N3	Miramar	1.0	1.0	1.0	1.0	1.1	1.1	Morena Diversion
N4	UCSD	3.4	3.6	3.7	3.8	3.8	3.8	
N5	San Clemente Canyon/Rose Canyon Old	1.0	1.0	1.0	1.0	1.1	1.1	
N6	Balboa	1.0	1.0	1.0	1.1	1.1	1.2	
N7	Second La Jolla/Pacific Beach	5.7	5.9	6.1	6.3	6.5	6.8	
N8	Tecolote Canyon	3.1	3.1	3.1	3.1	3.1	3.2	
N9	East Mission Gorge	14.8	15.7	16.6	17.6	18.4	19.4	Tributary to the South Bay Plant
N10	North Mission Valley	32.3	33.3	34.4	35.8	37.1	38.6	
N11	South Mission Valley	3.6	3.6	3.6	3.6	3.8	3.9	
N12	Ocean Beach	3.9	4.0	4.2	4.3	4.4	4.6	
N13	East Point Loma	2.0	2.1	2.1	2.1	2.2	2.2	
North Metro Interceptor (to PS2)		82.8	86.3	89.9	93.3	96.0	99.2	Spring Valley 8 Diversion
S1	Grove Avenue Pump Station (Existing)	8.2	9.7	11.3	12.0	12.4	12.9	
S2	Imperial Beach	0.9	0.9	0.9	0.9	0.9	0.9	
S3	Palm City	2.5	2.6	2.7	2.7	2.8	2.9	
S4	Salt Creek Trunk Sewer CV14	3.2	3.7	4.3	5.1	5.6	6.2	
S5	Chula Vista CV2	4.5	4.8	4.8	4.9	5.0	5.0	
S6	Chula Vista CV3	2.0	2.0	2.0	2.0	2.1	2.1	
S7	Spring Valley Trunk Sewer SV8	12.5	13.1	13.8	14.0	14.0	14.0	
S8	National City NC2	0.4	0.5	0.5	0.5	0.5	0.6	
S9	National City NC3A	2.9	3.1	3.3	3.7	4.2	4.6	
S10	National City NC5	0.9	1.0	1.0	1.1	1.2	1.3	
S11	Harbor Drive Trunk Sewer	21.4	24.8	28.3	29.5	30.4	31.6	
S12	Downtown/Coronado SD7A	6.0	7.6	9.2	9.8	10.1	10.6	
South Metro Interceptor (to PS2)		74.4	80.1	85.8	89.6	92.2	95.7	
Metro System Total		157.8	167.1	176.4	183.6	188.8	195.6	

Notes:

- Flows at key locations in the Metro System are provided. See Figure 4-11 and 4-12 for locations. A flow of approximately 0.7 mgd from the Point Loma area joins Point Loma Plant influent downstream of Pump Station 2. Flows are based on mid-point unit generation rates and SANDAG Series 12 data. 2015 values interpolated using 2010 and 2020 values. Grove Avenue PS 2010 flow based on South Bay Plant influent from Jan 2009 to June 2009. Flows are user generated flows and do not account for upstream diversions.
- Dry weather flows do not include wet weather related return events. The flows above were used for sizing the recycled water projects as these flows are considered the typical operating condition.



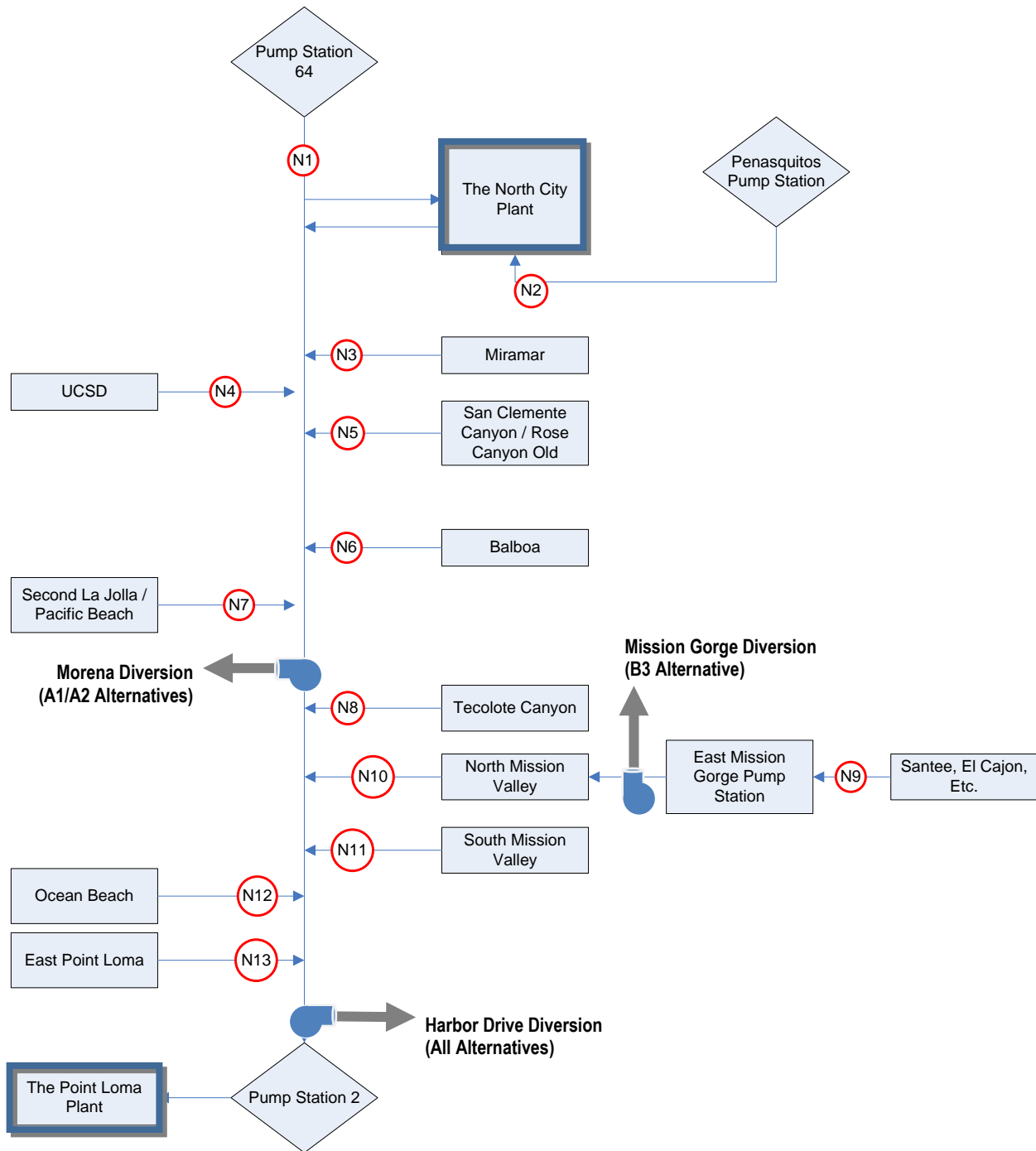

Figure 4-11. Schematic of the Metro System's North Area Trunk Sewers
 The Diversions shown are included in the Study's Alternatives, as described in Chapters 7 and 8.

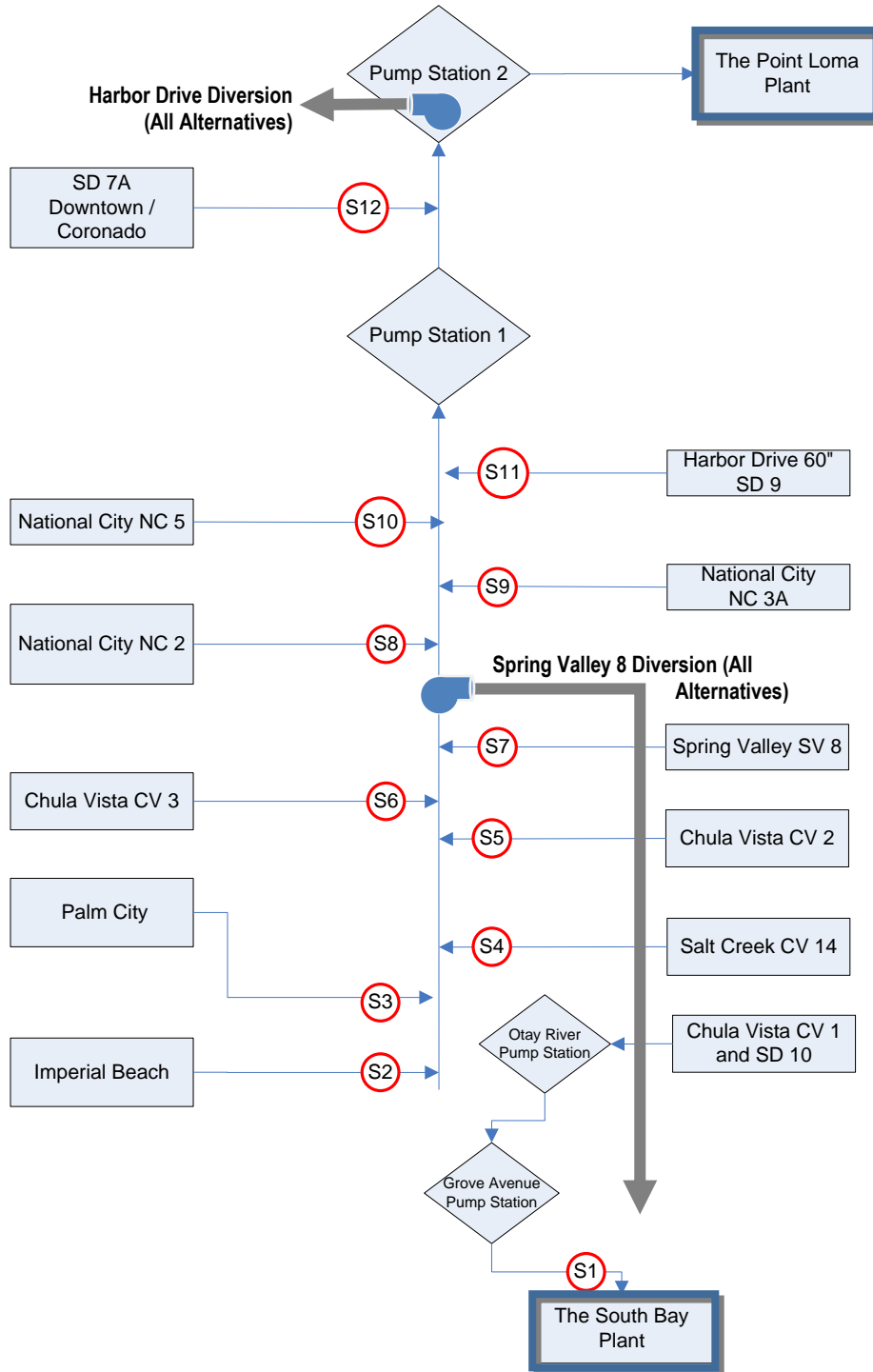

Figure 4-12. Schematic of the Metro System's South Area Trunk Sewers
 The Diversions shown are included in the Study's Alternatives, as described in Chapters 7 and 8.

4.4.6 Water Losses from Treatment Process

Losses occur as water is cleaned and treated. The amount of water lost as wastes varies depending on the specific processes used. Losses are important in water reuse, since the available wastewater must be treated through multiple processes to convert it to tertiary water for non-potable recycled water projects and then further treated for indirect potable reuse projects. Each treatment step removes part of the waste stream as shown in Figure 4-13, reducing the amount of water available. If there is not enough wastewater tributary to a treatment plant for water reuse projects, then the flows must be supplemented by diverting (usually through pumping) from another location. The adaptive model summarized in Chapter 3 accounted for the changing water volumes as water was treated to higher water quality levels.

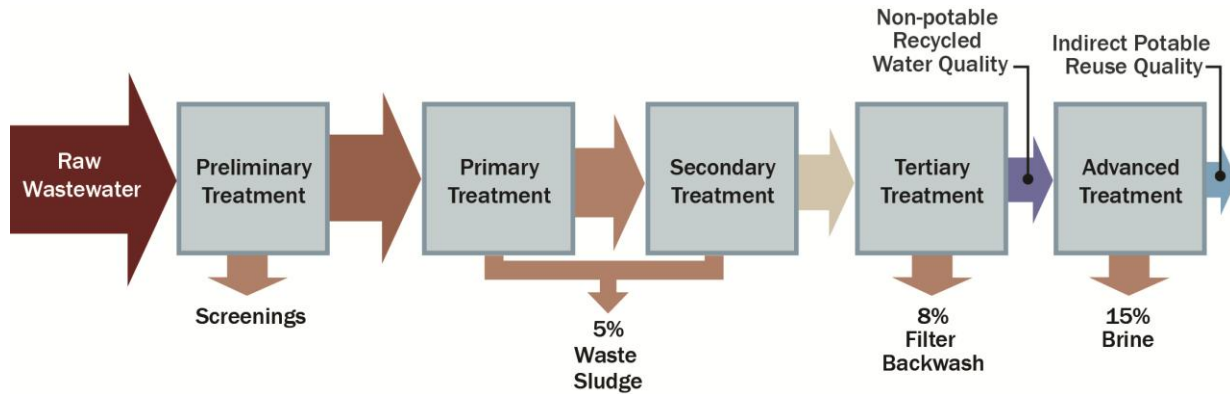

Figure 4-13. Typical Water Losses in Water Reclamation and Advanced Water Purification Treatment Processes

This page intentionally left blank.



5. NON-POTABLE RECYCLED WATER OPPORTUNITIES

The Study included evaluating two primary approaches to water reuse. The first was to increase non-potable recycled water use through expansion of the existing system or development of new systems. The second was to develop new indirect potable reuse projects using reservoir augmentation or groundwater recharge. This chapter describes the technical basis and foundation for developing non-potable recycled water opportunities. The opportunities outlined in this chapter were considered for incorporation into the Area Concepts described in Chapter 7 and then developed further into the Integrated Reuse Alternatives described in Chapter 8.

5.1 Non-potable Recycled Water Opportunities Summary

Non-potable recycled water opportunities were determined by calculating existing demands and estimating future demand potential. Delivering water to new customers requires expanding the existing non-potable reuse system by using the existing reclamation plants, or creating new systems through building new satellite plants near the location where the demands exist. Areas throughout the City were considered using a market assessment process (a study to estimate potential customer demands). Wholesale opportunities were also assessed through the use of agency surveys. The following section summarizes the non-potable recycled water opportunities considered.

5.2 Baseline Non-potable Recycled Water Demands

The North City and South Bay Plants currently serve non-potable recycled water to customers within the City, and to the wholesale customers Otay, City of Poway, and Olivenhain Municipal Water District through wholesale connections. Existing demand commitments to these customers is important since these demands need to be accounted for and subtracted from the total water available in order to determine how much water remains for the new opportunities investigated in this Study. These existing demands were referred to as the baseline demand condition. During the Study, the baseline demands were expanded to include near-term non-potable recycled water contracts (such as the Otay Water District contract through 2026) and the City's planned projects through 2015.

The following summarizes the baseline demand components:

- **Existing Demands.** Existing demands were quantified by averaging the 2009 and 2010 demand data at the North City Plant and the South Bay Plant. This was deemed appropriate to account for recent demand variability due to drought, water efficiencies, water conservation, and the strained economic climate.
- **North City Demands Planned through 2015.** The increase in the North City demands anticipated by 2015 was based on an active list of projects and planned connections maintained by the Public Utilities Department. Examples of new demands include implementing Phase II of the 2005 Recycled Water Master Plan and infill customers that have agreements with the City to connect to the existing system.

- **South Bay Plant Demands Planned through 2015 (City’s retail system).** The changes in the South Bay retail system demand anticipated by 2015 were based on an active list of projects and planned connections maintained by the Public Utilities Department. The South Bay retail system demands are anticipated to decrease due to the reduced demands at the International Boundary and Water Commission Plant.
- **South Bay Demands Planned through 2026 (Otay Water District).** Otay demands included in the baseline totals were based on an agreement between the City and Otay. The totals include increased demands through 2026. The South Bay Plant serves demands in excess of Otay’s Chapman Plant.

Table 5-1 summarizes the baseline demand totals. These totals are consistent for each reuse alternative included in the Report. A breakdown of wholesale customer contributions is included in the subsequent section. The non-potable recycled water demands shown were assumed to grow to these values over the period indicated, and remain at the totals shown in perpetuity. New water reuse opportunities (both non-potable and indirect potable reuse) were considered only after these demands were accounted for.

Area/Component	Existing Demands 2009/2010		Planned Demands 2010-2015/2026		Total Annual Baseline Demands	
	AFY	MGD	AFY	MGD	AFY	MGD
North City Plant Total	7,463	6.7	2,740	2.4	10,203	9.1
South Bay Plant Total	4,747	4.2	2,001	1.8	6,747	6.0
Total North City Plant & South Bay Plant	12,210	10.9	4,741	4.2	16,950	15.1

Notes:

- Demands shown are average annual demands. Seasonal demand impacts addressed below.
- Existing demands based on an average of calendar year 2009 and 2010 plant data provided by the City.
- Planned demands for the system (except Otay Water District) include new demands through 2015 based on the Recycled Water Demand Projections managed by City of San Diego Public Utility Department Recycled Water Program. Planned demands for the Otay Water District include demand projections through 2026 based on contract totals between the City and the Otay Water District. Otay Water District demands shown do not include Chapman Plant supplies totaling 599 AF in 2015 and 992 AF for 2026 and later years based on data provided by the Otay Water District. For planning purposes, 900 AFY was assumed to be available from the Chapman Plant.

5.3 Future Non-potable Recycled Water Opportunities

Future non-potable recycled water demand opportunities were developed as options to weigh in favor of and against indirect potable reuse approaches. These opportunities were reviewed and discussed during the workshops and Stakeholder meetings. Discussions included different viewpoints on non-potable reuse ranging from: 1) a desire to eliminate non-potable reuse once indirect potable reuse is implemented; to 2) a desire to continue non-potable reuse where appropriate, and to prevent having stranded assets from prior investments. Figure 5-1 summarizes the market assessment process used to refine raw demand data into projected non-potable recycled water demands for different opportunities, locate the demands, layout conceptual systems to determine costs, and then refine the demands based on historical connection rates.



Figure 5-1. Non-potable Recycled Water Opportunity Development



5.3.1 Future Citywide Non-potable Recycled Water Opportunities

Citywide future non-potable recycled water opportunities were compiled based on the market assessment. The market assessment included three key sources of information: 1) the City’s potable water customer database to identify irrigation customers, 2) the City’s industrial waste dischargers database to identify potential cooling tower customers, and 3) phone surveys conducted by the Study Team with commercial and industrial customers who use large quantities of potable water. Focus areas were broken out based on the demand concentrations to facilitate laying out conceptual distribution systems as shown on Figure 5-2. The focus areas and the demands are summarized in Table 5-2. The focus areas are broken out into two categories—those served by existing plants and those served by new plants.

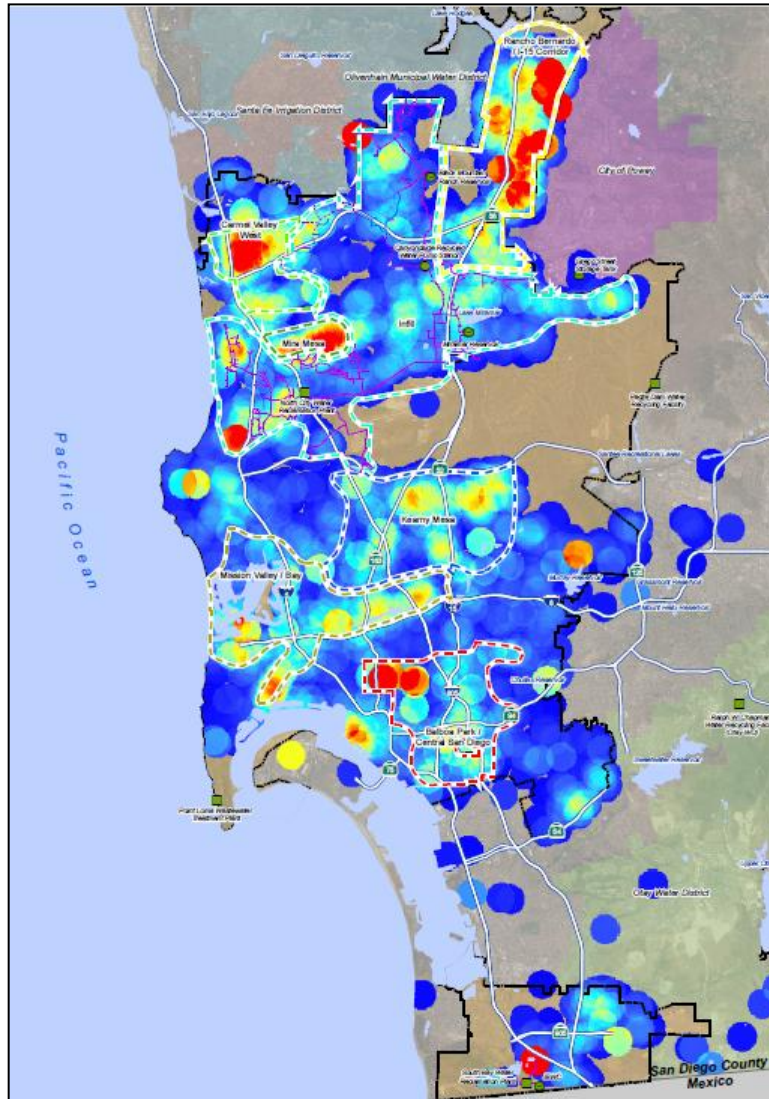

Figure 5-2. Non-potable Recycled Water Opportunity Density Map
 A map was prepared to show the concentration of water demands that were candidates for conversion to non-potable recycled water. Red areas represent the highest concentration of potential demands and dark blue areas represent areas with the lowest potential conversion demands.

Table 5-2. Citywide Future Non-potable Recycled Water Opportunities Considered

Focus Area	Annual Demands	
	AFY	mgd
Areas served from existing treatment plants		
Infill	2,693	2.4
Balboa Park/Central San Diego	1,132	1.0
Carmel Valley West	546	0.5
Kearny Mesa	539	0.5
Mira Mesa	294	0.3
Mission Valley/Bay	1,146	1.0
Rancho Bernardo/I-15 Corridor	2,634	2.4
Areas served by new treatment plants		
Balboa Park/Central San Diego	1,108	1.0
Kearny Mesa	615	0.5
Mission Valley/Bay	1,130	1.0
Rancho Bernardo/I-15 Corridor	2,620	2.3

Notes:

- Annual demands are adjusted based on historical conversion/connection rates. Focus areas served by new plants are not additive to the same Focus Areas listed above under those served by existing plants; rather, they are alternative approaches.

5.3.2 Future Wholesale Non-potable Recycled Water Opportunities

Non-potable recycled water opportunities were also investigated to serve wholesale customers. The market assessment included surveying 11 agencies for possible service. From the surveys, five agencies were identified for further consideration. The agencies considered and the actions taken are summarized as follows:

- **City of Coronado.** The City of Coronado is served by California American Water, a private water company. The survey for the City of Coronado indicated a potential demand of 460 AFY (0.4 mgd) for the City of Coronado, and 920 AFY (0.8 mgd) for potential Navy demands. These demands were not carried forward in this Study since the Navy is investigating construction of an independent plant to meet both Navy and City of Coronado demands.
- **City of Poway.** The City of Poway indicated that they would have additional demands of 1,100 AFY (1.0 mgd) through a new northern connection through Rancho Bernardo. The northerly connection was conceptualized in the City's 2000 Beneficial Reuse Study, but funding would need to be identified for the significant conveyance system expansion needed for this option. These demands were considered in the Rancho Bernardo/I-15 Corridor Area Concept summarized in Chapter 7. While this option was not included in the Integrated Reuse Alternatives, they were noted as a candidate project for a privately funded water offset project (see Chapter 7).
- **Olivenhain Municipal Water District.** The Olivenhain Municipal Water District survey demands were within the totals the City had identified in the 2015 baseline demand condition (described above). Therefore, no additional demands were carried forward beyond what was already included in the baseline demands.
- **Otay Water District.** Otay provided projected demand increases in addition to the demands included in the baseline demand condition. The demand increases occur between 2026 and 2040, and amounted to an increase reaching 3,363 AFY (3.0 mgd) annually. These demands were considered and advanced in the South Bay Area Concepts summarized in Chapter 7.
- **Santa Fe Irrigation District.** Santa Fe Irrigation District provided a potential demand of 850 AFY (0.8 mgd) to serve an existing distribution system and to expand service to the eastern portion of their service area. Santa Fe Irrigation District was also assessing other supply opportunities during this period. These demands were considered, but not advanced in lieu of other North City/San Vicente alternatives due to limited water availability at the North City Plant and uncertainty regarding this opportunity.

5.3.3 Other Agency Reclamation Plant Considerations

It is important to note that other Participating Agencies have effective non-potable recycled water programs in place. Padre Dam and Otay each treat and distribute recycled water at and from existing facilities (summarized in Chapter 4). These efforts have helped to offload the Metro System, and have provided a reliable water resource to the region. These systems were considered in the Study analysis since their operation affects the amount of wastewater available for treatment at downstream facilities and, in Otay's case, the amount of recycled water needed at the South Bay Plant to meet their demands. The following summarizes these considerations:

- **Padre Dam Water Recycling Facility.** It was assumed that approximately 2,240 AFY (2.0 mgd) of existing non-potable reuse and 1,120 AFY (1.0 mgd) of future non-potable reuse would be produced at the Padre Dam Water Recycling Facility. This does not include the El Monte indirect potable reuse project, which was considered separately as described in the indirect potable reuse project section.
- **Chapman Plant.** Otay meets their non-potable reuse demands from the South Bay Plant and the Chapman Plant. Data provided by Otay projected Chapman Plant recycled water production rate to

vary between 465 to 1162 AFY. These totals were subtracted from the total Otay demands to determine the remaining amounts needed from the South Bay Plant.

5.4 Non-potable Recycled Water Carried Forward in the Study

The amount of non-potable reuse advanced to the Area Concepts (and ultimately the Integrated Reuse Alternatives) was determined through the collaborative Study process. The opportunities were presented and debated throughout the early stages of the Study, with Stakeholder input occurring at the status meetings and as part of the Coarse Screening Session. Opportunities were weighed against the water reuse goals developed to offload the Point Loma Plant, the project criteria, and the benefits derived.

The first limitation with non-potable recycled water demands was identified by comparing the market assessment to the Study goals. The market assessment for both City retail customers and wholesale customers (not including planned and contracted totals) amounted to approximately 23 mgd for North City and 4 mgd for South Bay. This fell well short of the water reuse target in this Study. To further evaluate non-potable recycled water, a comparative analysis was performed on Alternative B2 (described in Chapter 8). The comparative analysis used the B2 Alternative both with and without a non-potable recycled water system expansion to the Rancho Bernardo area using the North City Plant. Rancho Bernardo was selected for this analysis since it included the largest concentration of potential non-potable recycled water demands and was the closest to existing facilities. The analysis concluded that adding the non-potable recycled water element to the B2 Alternative increased the unit cost of the water produced by approximately 8-percent. While non-potable recycled water projects can be beneficial, the analysis did show the cost effectiveness of doing larger scale indirect potable reuse projects that don't require extensive conveyance networks and the separate billing and customer support systems associated with individual recycled water customers. These factors shaped the approach to utilize non-potable options in a modest fashion, with a majority of the new reuse coming from larger indirect potable reuse projects.

While the non-potable recycled water opportunities carried forward could be considered modest, they represent a balanced approach to maximizing existing City and Participating Agency assets. The non-potable recycled water demands carried forward can be summarized as the Baseline Demands plus 3 mgd for expanded service to Otay occurring between 2026 and 2040. Figure 5-3 displays the projected growth in non-potable demands for each agency. Table 5-3 summarizes the non-potable demands carried forward for both the North City the South Bay Plants.

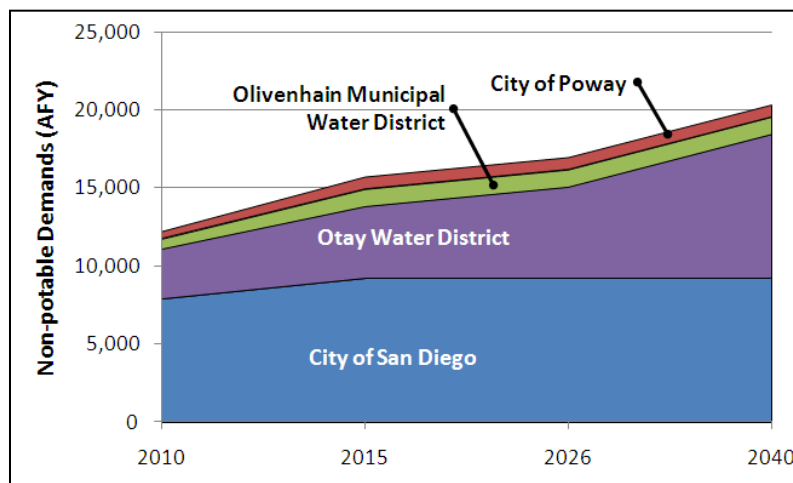

Figure 5-3. Projected Non-potable Recycled Water Demands

Average annual non-potable recycled water demands are projected to rise through 2040 based on the non-potable opportunities targeted for the for the North City and South Bay Plants

Table 5-3. Non-potable Recycled Water Projected Demands

Agency	Existing		Planned		Planned (OWD)		Future (OWD)		Total	
	2009/2010		2010-2015		2015-2026		2026-2040			
	AFY	mgd	AFY	mgd	AFY	mgd	AFY	mgd	AFY	mgd
North City Plant										
City of San Diego	6,394	5.7	1,959	1.7	0	0.0	0	0.0	8,353	7.4
City of Poway	428	0.4	323	0.3	0	0.0	0	0.0	751	0.7
Olivenhain Municipal Water District	642	0.6	458	0.4	0	0.0	0	0.0	1,100	1.0
Total North City	7,464	6.7	2,740	2.4	0	0.0	0	0.0	10,204	9.1
South Bay Plant										
City of San Diego	1,539	1.4	-639	-0.6	0	0.0	0	0.0	900	0.8
Otay Water District	3,209	2.9	1,395	1.2	1,243	1.1	3,363	3.0	9,210	8.3
Total South Bay	4,748	4.2	756	0.7	1,243	1.1	3,363	3.0	10,110	9.0
North City and South Bay Plants										
Total Combined	12,212	10.9	3,496	3.1	1,243	1.1	3,363	3.0	20,314	18.1

Notes:

- Demands shown are average annual demands. Seasonal demand impacts addressed below.
- Existing demands based on an average of calendar year 2009 and 2010 plant data provided by the City.
- Planned demands for the system (except Otay Water District) include new demands through 2015 based on the Recycled Water Demand Projections managed by City of San Diego Public Utility Department Recycled Water Program. Planned demands for the Otay Water District include demand projections through 2026 based on contract totals between the City and the Otay Water District. Otay Water District demands shown do not include Chapman Plant supplies totaling 599 AF in 2015 and 992 AF for 2026 and later years based on data provided by the Otay Water District.
- Otay Water District Demands between 2026 and 2040 carried forward into the Coarse Screening Session varied by option. The totals shown herein are from Option C2, described in Chapter 8, which included 3.0 mgd of demands. Option C2 was used in all of the Integrated Reuse Alternatives presented in Chapter 8.

5.4.1 Seasonal Demand Considerations

Non-potable recycled water usage is highly affected by the seasons since a majority of the water serves landscaping. Demands peak in the summertime, with a general rule of thumb being that peak summer day demands will be twice the average annual demands. The seasonal fluctuation is an important constraint for non-potable recycled water systems since serving peaks requires sizing treatment plants and storage facilities large enough to handle the highest demand condition. This generally means that the treatment plant capacity must be two times larger than the average demands, resulting in potentially underutilized capacity at the treatment plants. Optimization through peak management has become a major focus for all infrastructure systems. Examples include off-peak electrical rate incentives to reduce electrical loads during peak usage periods, and freeway carpool programs to lessen the volume of cars during peak commuting hours. For water reuse, agencies with underutilized plants are looking towards indirect potable reuse to optimize unused treatment capacities. Other concepts involve pricing incentives to help lower peak usage.

Seasonal non-potable recycled water demands were developed for the North City Plant (Figure 5-4) and the South Bay Plant (Figure 5-5). The curves represent monthly estimates based on historical monthly peaking factors provided by the City and Otay. It is important to note that peak day demands can exceed these totals in summer months. The seasonal curves include the following:

- Existing demands based on flow records from 2007 through 2010.
- Planned and future demands, including:
 - City of San Diego, City of Poway and Olivenhain Municipal Water District planned demands through 2015.
 - Otay planned demands through 2026 and future demands through 2040 (these totals do not include flows provided by the Chapman Plant).

Also shown is the remaining tertiary water available based on plant capacities and projected wastewater flows through 2035 (see Chapter 4 for wastewater assumptions). The North City Plant uses the existing plant capacity and projected 2035 wastewater flows without additional diversions. The South Bay Plant assumes an additional wastewater diversion using the Spring Valley No. 8 connection. Diversions are described further in Chapter 8. This remaining water can be used to meet peak day demands and serve new indirect potable reuse projects that optimize the remaining treatment plant capacities.

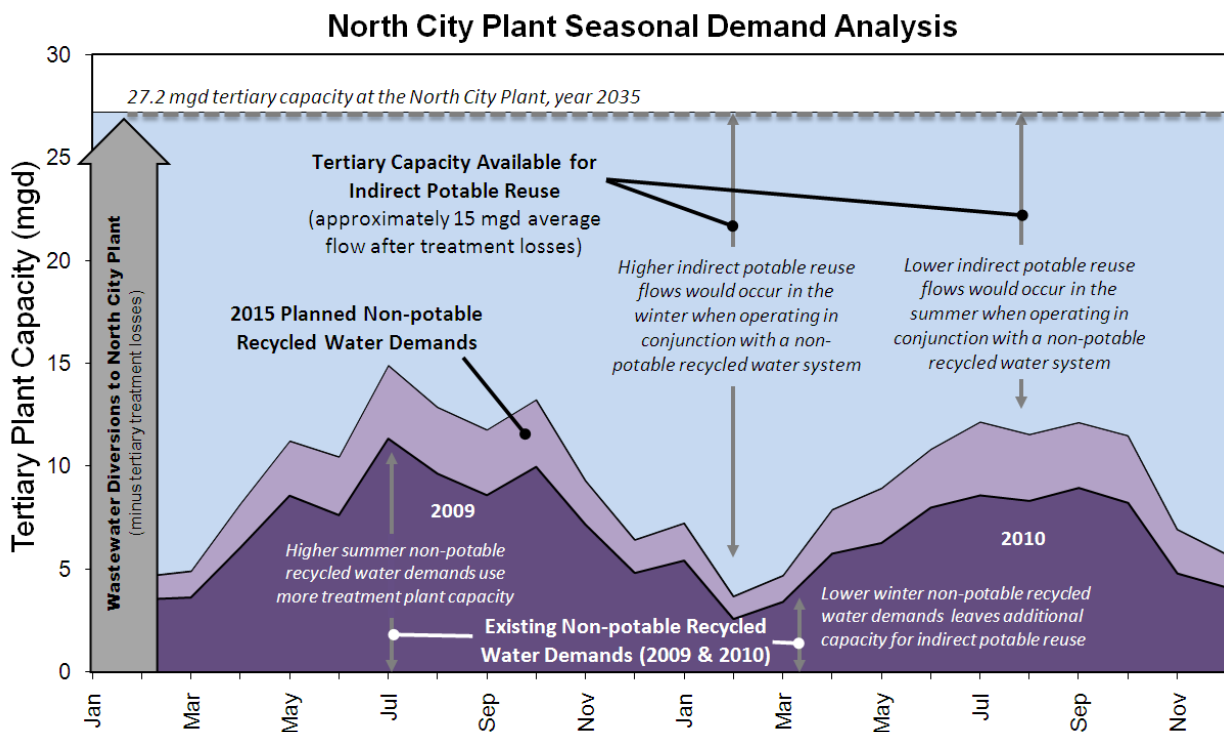

Figure 5-4. Seasonal Demand Analysis at the North City Plant

Non-potable reuse is highly influenced by seasonal peak demands. Higher summer demands affect the ability to utilize the entire plant capacity. The remaining capacity at the North City Plant, after planned non-potable recycled water demand increases through 2015, is allocated to indirect potable reuse.

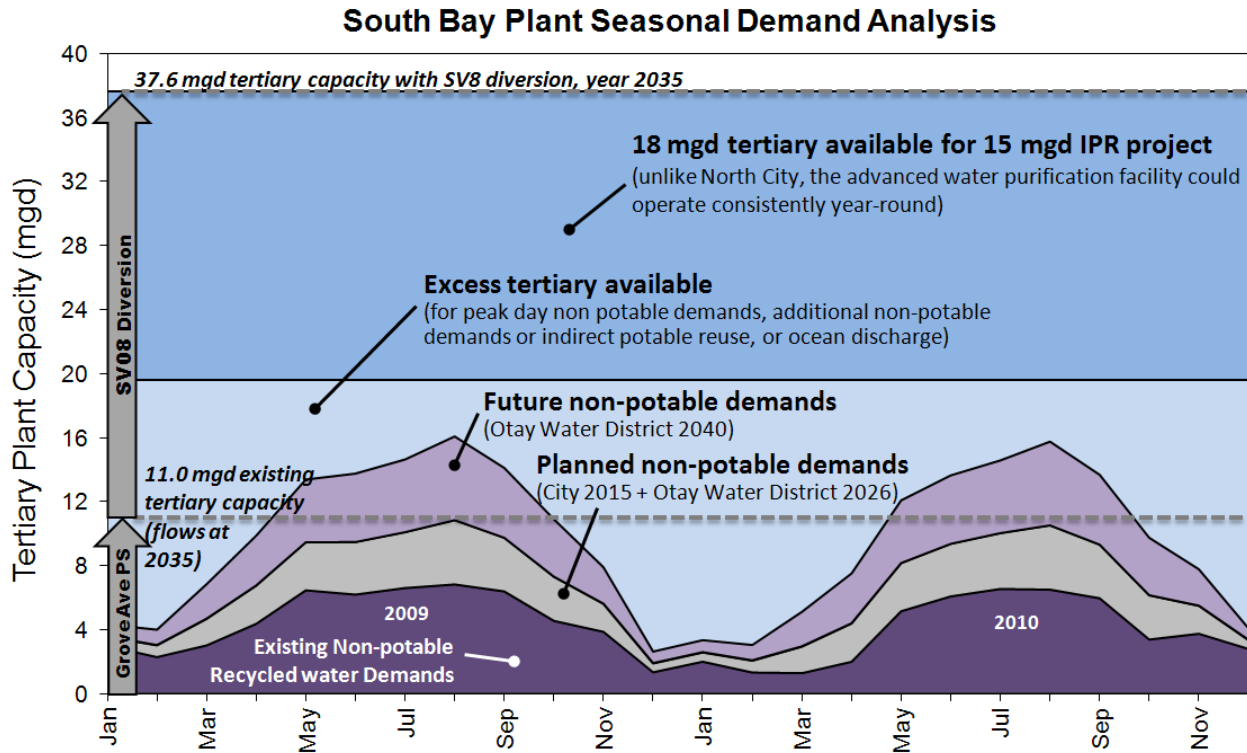

Figure 5-5. Seasonal Demand Analysis at the South Bay Plant

The planned South Bay Plant Spring Valley 8 (SV8) Diversion creates a different situation than the North City Plant. The SV8 Diversion provides enough wastewater to produce treated water to meet non-potable needs and a base loaded Advanced Water Purification Facility/indirect potable reuse project. Excess treated water could be used to meet the difference between peak day demands (peak month demands shown) or additional reuse. The South Bay Plant would be expanded from 15 mgd to approximately 45 mgd (influent capacity). The tertiary capacities shown are lower than influent capacities due to treatment losses. Additional treatment losses occur between the tertiary and advanced purification processes for indirect potable reuse projects.

6. INDIRECT POTABLE REUSE OPPORTUNITIES

The Study evaluated two primary approaches to water reuse. Chapter 5 summarized the non-potable recycled water opportunities. This chapter describes the technical basis and foundation for developing the indirect potable reuse opportunities. In addition, this chapter also includes discussion on the potential for regulatory changes allowing direct potable reuse and how those changes could impact the indirect potable reuse opportunities. The project opportunities outlined in this Chapter were considered for incorporation into the Area Concepts described in Chapter 7 and then developed further into the Integrated Reuse Alternatives described in Chapter 8.

6.1 Indirect Potable Reuse Summary

Indirect potable reuse is the planned addition of purified recycled water to domestic drinking water (potable water) supplies. The term “indirect” refers to the distinction that the purified water is mixed with a natural water source prior to delivery to customers. The purified recycled water meets rigid state and national water quality standards, and is often of higher quality than the natural water (or untreated water) with which it is mixed. The two general categories related to indirect potable reuse are groundwater recharge and reservoir augmentation. Groundwater recharge involves purifying the water using advanced treatment processes and then recharging the water into groundwater basins with injection wells or through surface spreading. Extraction of the water may involve treatment at the well site. Reservoir augmentation involves purifying the water using advanced treatment processes and then adding the water to a surface water reservoir located upstream of a drinking water treatment plant. The water from the reservoir is then further treated at a downstream drinking water plant before being distributed to customers.

Many communities in the United States and throughout the world are currently practicing or are planning indirect potable reuse projects. The largest and most well-known project in the world has been implemented just north of San Diego in Orange County, California. The Orange County Groundwater Replenishment System, which began operation in January 2008, can produce up to 70 mgd of highly purified recycled water that serves the water demands of nearly 600,000 residents. The project is currently being expanded to 100 mgd with an anticipated operational start-up in 2014. This system requires less than half the energy needed to pump imported water from northern California to southern California and less than one third of the energy required for desalination of seawater.

Indirect potable reuse projects also produce water low in total dissolved solids (TDS), which is helping to improve water quality in areas with impacted water supplies—a major issue for southern California due to high salinity of imported water sources. For example, the Groundwater Replenishment System produced water with final product water having a TDS level from 35 to 50 milligrams per liter (mg/L); whereas, water entering San Vicente Reservoir from January 2009 through July 2011 had an average TDS value of approximately 500 mg/L.



Orange County, CA Groundwater Replenishment Facility. The Groundwater Replenishment facility is just north of San Diego, and is recharging enough purified recycled water into the groundwater supply to serve 600,000 residents – with a superior water quality that is improving the basin.

The success of the Groundwater Replenishment System and the many benefits of indirect potable reuse have generated a trend towards this approach. In Riverside County, the City of Riverside, the Western Municipal Water District, and the Eastern Municipal Water District are each planning indirect potable reuse projects. Santa Clara Valley Water District in San Jose is planning a 10 mgd indirect potable reuse project with plans to increase the capacity to 40 mgd. The Los Angeles Department of Water and Power is also planning a 13 to 27 mgd indirect potable reuse project (*Los Angeles Department of Water and Power flows based on the LADWP website, 2011; other project data provided by WaterReuse California, 2011*). Likewise, the trend has increased in San Diego County with the proposed El Monte Groundwater Recharge Project (currently on hold, but indirect potable reuse planning ongoing). The City of Escondido is also considering indirect potable reuse project concepts.

Specific to San Diego County, the current Study concluded that indirect potable reuse presented a greater potential to reduce the amount of wastewater reaching the Point Loma Plant by achieving larger scale and less seasonally dependent options compared to non-potable reuse approaches. Non-potable recycled water is driven by seasonal demands and requires the Point Loma Plant to retain treatment and disposal capacity during low demand periods (such as rain events when irrigation demands decline). Non-potable recycled water also requires maintaining a separate distribution system, separate accounting and billing, and separate testing programs, which impacts costs as described in the cost comparison in Section 5.4.

6.2 Indirect Potable Reuse Benefits

The goal of the 2005 Water Reuse Study was to maximize the available capacities at the North City and South Bay Plants, which amounted to approximately 20 mgd. To achieve this, the 2005 Water Reuse Study, and the related American Assembly Stakeholder group, favored indirect potable reuse with limited expansion of non-potable recycled water approaches. In comparison, this current Recycled Water Study expanded the water reuse potential by considering all the available wastewater in the Metro System available for reuse – up to 215 mgd. The increased scale further reinforced the need to look for larger projects with improved economy of scale. Indirect potable reuse projects provided the needed scope and scale for this purpose. Indirect potable reuse and non-potable recycled water opportunities were debated in the Stakeholder meetings, and the following benefits were highlighted related to indirect potable reuse.

- **Indirect potable reuse maximizes unused plant capacities, is generally not seasonally limited, and provides local control.** When coupled with a non-potable recycled water operation, indirect potable reuse can use the remaining water to maximize the overall plant capacity (as shown in Figure 5-4 of the previous chapter). When not influenced by a non-potable recycled water system, indirect potable reuse plants can deliver water consistently year-round since the delivery points (large surface reservoirs or groundwater basins) are large enough to accommodate constant inflows. Therefore, indirect potable reuse can maximize the ratepayer's investments, particularly at the North City Plant, by using the treatment capacity left over after non-potable recycled water demands are met. (Reference Figure 5-4 in the previous chapter for a graphical representation on how indirect potable reuse utilizes the unused capacity at the North City Plant). Indirect potable reuse also provides a locally controlled water source available to supplement or offset imported water supplies.
- **Indirect potable reuse provides large Point Loma Plant offsets.** Indirect potable reuse can provide water reuse opportunities to reduce flows to the Point Loma Plant and ocean discharges and create a new source of water supply. Ratepayer savings increase further when enough flow is diverted to permit simpler, less costly upgrades at the Point Loma Plant (see the Point Loma Plant offset discussion in Chapter 8). Non-potable reuse opportunities identified in the Study cannot achieve the same level of offset at lower costs.
- **Indirect potable reuse water has a superior ability to improve water quality in Southern California.** Salt management is becoming a key water quality consideration for Southern California. The imported water supply, particularly Colorado River water, has high TDS levels. Indirect potable reuse water would reduce salinity levels in the reservoirs, at homes, and in soils. Local indirect

potable reuse projects could produce water with salinity levels 20 times lower than non-potable recycled water and 10 times lower than the drinking water currently delivered to residents, thereby improving reservoir water quality.

- **Few Limitations in Reuse Application.** Indirect potable reuse provides high quality water that is of equal or better quality than untreated imported water. Therefore, this water has virtually unlimited use opportunities. It is a locally developed sustainable water supply that is uninterrupted and is not affected by outside influences such as drought, water rights, and other supply interruptions.
- **Maximizes sustainability.** Indirect potable reuse is a sustainable water practice since it maximizes the use of an underutilized resource at a local level. The practice reduces the energy use and impacts caused by importing water long distances.

6.3 Indirect Potable Reuse Opportunities

Developing indirect potable reuse concepts requires an understanding of the constraints associated with recycled water supply availability, regulatory framework issues, infrastructure capacities, local runoff and water demands. Indirect potable reuse opportunities were categorized into two scenarios based on the supply source they were integrated with: reservoir augmentation using existing surface water reservoirs and groundwater recharge using existing groundwater basins. Of these two approaches, reservoir augmentation to surface water reservoirs offers the greatest opportunity for maximizing water reuse in the San Diego region. San Diego is fairly limited in groundwater capacity and relies more heavily on surface water reservoirs for storing local and imported water supplies. While there are opportunities to implement groundwater recharge projects in the region, the capacity of such projects is relatively small compared to some reservoir augmentation opportunities. Additional details and discussion regarding indirect potable reuse opportunities for both reservoir augmentation and groundwater recharge projects are presented below.

6.3.1 Reservoir Augmentation Opportunities

The region's surface water reservoirs offer opportunities for indirect potable reuse. The region uses surface water reservoirs to store a majority of its untreated water supply, which originates primarily from the Colorado River and the State Water Project. The untreated water is conveyed from these reservoirs to drinking water treatment plants, and then delivered to customers through a distribution system. The following regional reservoirs were initially considered for this study, which are also shown on Figure 6-1:

- Sutherland Reservoir
- El Capitan Reservoir
- Lake Hodges
- Lake Miramar
- Lake Jennings
- Lake Murray
- San Vicente Reservoir

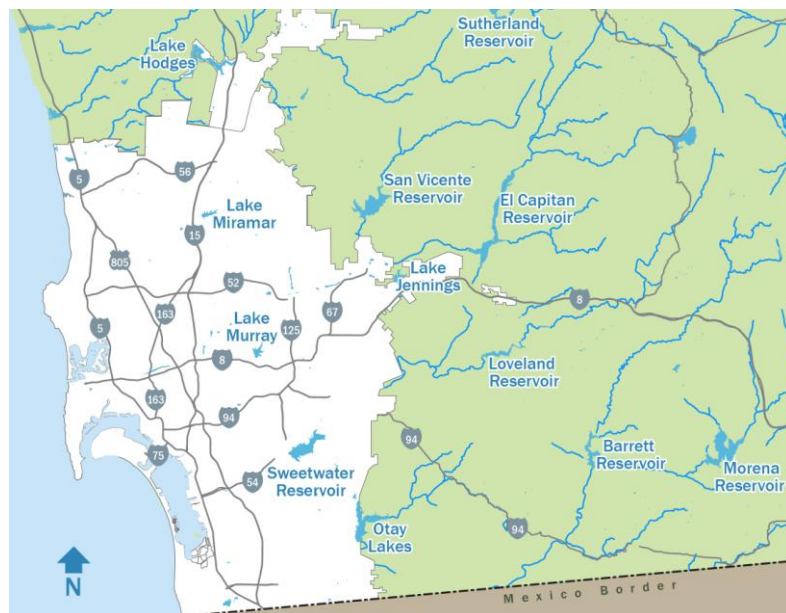





Figure 6-1. Surface Water Reservoirs Considered

- Morena Reservoir
- Barrett Reservoir
- Otay Lakes
- Sweetwater Reservoir

Reservoirs were evaluated and shortlisted based on their size, proximity to infrastructure (which relates to costs), ability to integrate with existing water treatment plants, anticipated characteristics related to regulatory compliance, and institutional complexity. The development of these opportunities and the constraints associated with them were discussed in the Stakeholder review meetings, including a detailed constraints discussion occurring in Status Update Meeting No. 5 held in May 2010.

Table 6-1 summarizes the reservoirs considered and advanced to the Coarse Screening Session. The table also contains the key considerations used in the screening process and discussed at the Stakeholder meetings. The potential project sizing shown was estimated by comparing the candidate reservoirs to the previously planned indirect potable reuse project at San Vicente. San Vicente was used for this purpose since it has been more thoroughly studied and modeled for indirect potable reuse use than any other reservoir in the region. San Vicente Reservoir, Otay Lakes, and Lake Hodges were advanced as candidate indirect potable reuse opportunities.

Table 6-1. Surface Water Reservoir Candidates Advanced









Reservoir	Storage Capacity (acre foot)	Indirect Potable Reuse Potential		Key Considerations
		AFY	mgd	
 <p>San Vicente (w/ Dam Raise)</p>	241,312 (89,312 pre-Dam Raise)	100,000	89	Recommended approach from 2005 Water Reuse Study, dam raise increases retention times and potential capacities, ability to distribute throughout the region and to the largest treatment plants.
 <p>Lower Otay</p>	49,849	25,000	22	Previous recommendation from 2005 Water Reuse Study, with proximity to South Bay Plant. Located adjacent to the 33 mgd (2035 capacity) Otay Water Treatment Plant.
 <p>Hodges</p>	30,251	18,000	16	Proximity to Pump Station 77 and available wastewater, City reuse history in San Pasqual area.

Note: Estimated indirect potable reuse project potentials based on adjusting the original San Vicente indirect potable reuse project (20 mgd in a 90,230 AF reservoir for a 2-year retention time) to the other reservoir capacities assuming a one year retention time. The regulatory criteria being developed as part of the Water Purification Demonstration Project will determine the feasible project size.

Table 6-2 summarizes the reservoirs that were considered, but not advanced to the Coarse Screening Session. The table also contains the key considerations used in the screening process and discussed at the Stakeholder meetings. Although Lake Murray and Miramar Lake were considered too small for indirect potable reuse projects at this time, potential project sizes were calculated since they are located at the two largest water treatment plants in the Metro Service Area. In addition, Lake Murray is downstream of the San Vicente Reservoir and may be considered integral with the San Vicente Reservoir opportunity. Lake Miramar could be served from the San Vicente Reservoir by operating the San Diego County Water Authority’s new San Vicente Tunnel and San Vicente Pump Station. Lake Jennings could be served by the San Vicente Reservoir, depending on how the Helix Water District manages their supply options.



Table 6-2. Surface Water Reservoir Candidates Not Advanced

Reservoir	Storage Capacity (acre foot)	Indirect Potable Reuse Potential		Key Considerations
		AFY	mgd	
 <p>Miramar</p>	6,682	3,000	3	Too small to meet anticipated regulatory requirements. As the regulatory environment for indirect potable reuse evolves, these requirements may become feasible. Located adjacent to the 215 mgd (2035 capacity) Miramar Water Treatment Plant.
 <p>Murray</p>	4,682	2,000	2	Too small to meet anticipated regulatory requirements. As the regulatory environment for indirect potable reuse evolves, these requirements may become feasible. Located adjacent to the 200 mgd (2035 capacity) Alvarado Treatment Plant.
 <p>Jennings</p>	9,790	-	-	Too small to meet anticipated regulatory requirements; distance from source waters; complex institution issues related to its operation by the Helix Water District and Helix's focus on a groundwater recharge project with the Padre Dam. As the regulatory environment for indirect potable reuse evolves, these requirements may become feasible.
 <p>Sweetwater</p>	28,079	-	-	Small size and institutional issues. Owned by Sweetwater Authority; any indirect potable reuse project would require participation and support from Sweetwater Authority. This includes the Loveland Reservoir.
 <p>Sutherland</p>	29,508	-	-	Distance from key infrastructure resulting in higher costs than other options.
 <p>Morena</p>	50,694	-	-	Distance from key infrastructure resulting in higher costs than other options.
 <p>Barrett</p>	34,806	-	-	Distance from key infrastructure resulting in higher costs than other options.
 <p>El Capitan</p>	112,807	-	-	Distance from key infrastructure resulting in higher costs than other options.

Note: Estimated indirect potable reuse project potentials based on adjusting the original San Vicente indirect potable reuse project (20 mgd in a 90,230 AF reservoir for a 2-year retention time) to the other reservoir capacities assuming a one year retention time (retention times ranging from six months to two years were considered). Sizing was not estimated for screened reservoirs, except Lake Miramar and Lake Murray since they are located adjacent to the two largest drinking water treatment plants in the Metro Service Area.

6.3.2 Groundwater Recharge Opportunities Considered

The region's groundwater basins offer additional opportunities for indirect potable reuse. While San Diego does not possess groundwater basins of the same scale as Los Angeles or northern Orange County, there are potential basins that were considered for indirect potable reuse projects. Groundwater recharge opportunities were conceptualized by locating a new advanced water purification facility. Water treated at this facility would be pumped to the targeted groundwater basin. At the basin, the water would be pumped into injection wells or placed in spreading basins and allowed to percolate into the groundwater aquifer. The method used to add water to the aquifer is dependent upon several factors, including the basin characteristics and geology and the land availability. The advanced treated water blends with native groundwater and is extracted downstream after meeting minimum regulated hydraulic retention times – a minimum amount of time required before extraction to comply with existing groundwater recharge regulations. The groundwater is then extracted using wells, potentially treated at the well (depending on the water quality), and lastly added to the drinking water system.

The following regional groundwater basins were considered for this study and are shown on Figure 6-2:

- El Monte Valley
- San Pasqual
- San Diego Formation
- Mission Valley
- Otay River
- Tijuana
- San Dieguito
- Carmel Valley

Evaluations performed during the Study confirmed (similar to the 2005 Water Reuse Study) that groundwater recharge opportunities in San Diego County are more limited than reservoir augmentation due to the size, yields, and characteristics of the local groundwater basins. Of the basins evaluated for groundwater recharge, the San Pasqual Basin was advanced for further consideration. The San Diego Formation was also considered. However, it was determined that limited information was available to develop a detailed alternative comparable to other options. The El Monte Groundwater Recharge Project was also advanced to the Coarse Screening Session.

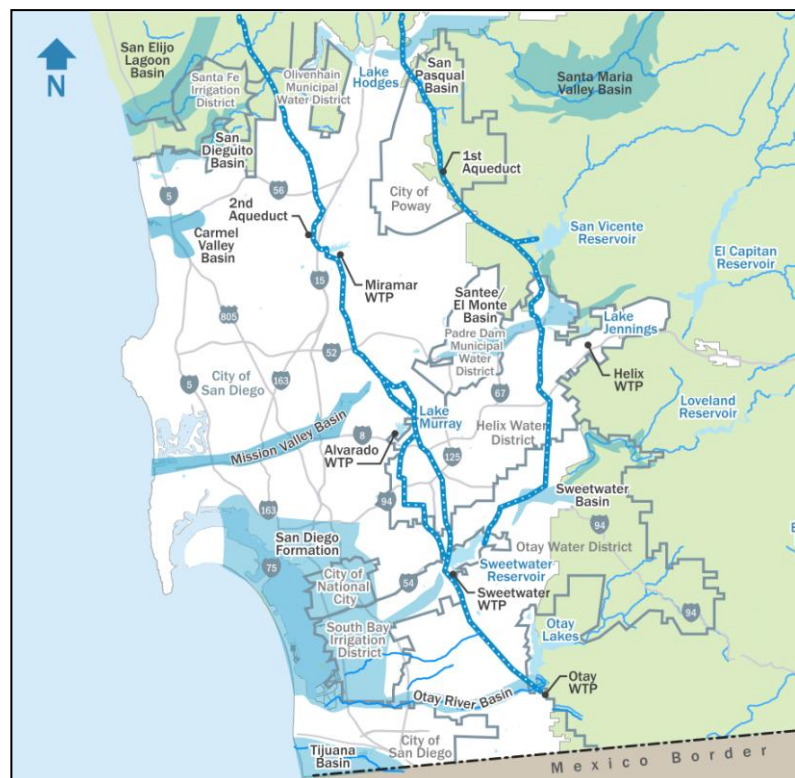



Figure 6-2. Groundwater Basins Considered

Table 6-3 summarizes the groundwater basins advanced to the Coarse Screening Session. The table also contains the key considerations used in the screening process and discussed at the Stakeholder meetings. The potential project sizing shown was estimated by comparing the candidate basins to the El Monte Valley basin using a six month hydraulic retention time. The El Monte basin was used for this purpose since it has been more thoroughly studied and modeled for groundwater recharge than any other basin in the region.





Reservoir	Storage Capacity (acre foot)	Indirect Potable Reuse Potential		Key Considerations
		AFY	mgd	
El Monte Valley (or similar project) 	10,000 to 50,000	5,000	4.5 to 5.0	The El Monte basin was evaluated by the Helix Water District and the Padre Dam Municipal Water District for an indirect potable reuse groundwater augmentation project. This project was coordinated with this Study since wastewater flows for this project affect downstream wastewater availability in the Metro System. Although this project is currently on hold, it or a similar project could further offload the wastewater system and provide valuable new water to the region. The status of this project is anticipated to be tracked as an Implementation Step.
San Pasqual 	58,000 to 73,000	2,900 to 11,600	2.6 to 10.4	The San Pasqual basin has several characteristics suitable for an indirect potable reuse project – proximity to wastewater, a history of reuse, City owned land, and detailed background information. Recharge may also improve degraded groundwater upstream of Lake Hodges, and the shallow portions of the basin may be suitable for meeting regulatory requirements. These benefits are countered by some limitations. The basin has a large tributary area with suitable blending supplies, but not a lot of volume for blending. There are numerous existing potable and agricultural wells in the area that would require meeting certain regulatory provisions. Also, the San Pasqual basin, and more importantly its connectivity to Lake Hodges, is complex from an institutional standpoint. Lake Hodges water can be transported to the Santa Fe Irrigation District, San Dieguito Water District and Olivenhain Municipal Water District and also includes SDCWA operations. While this does not eliminate San Pasqual from consideration, challenging permitting and institutional issues would need to be addressed.

Notes:

- Basin storage capacity derived from Department of Water Resources Bulletin No. 118 and SDCWA Groundwater Report, dated June 1997.
- Reuse potential sizing calculated by comparing the candidate basin to the El Monte Groundwater Recharge Project. El Monte Groundwater Recharge Project data based on recent studies provided by Helix Water District. Potential sizing shown based on a six month retention time, consistent with recent regulatory trends (three month to two year retention times were considered).

Table 6-4 summarizes the groundwater basins not advanced to the Coarse Screening Session. The table also contains the key considerations used in the screening process and discussed at the Stakeholder meetings. As noted previously, the San Diego Formation was closely considered for advancement to the Coarse Screening Session; however, the lack of information prevented this alternative from being fully developed into a comparable option. The ongoing work between the City and United States Geological Service regarding the San Diego Formation will allow re-visiting this option in future planning efforts. The remaining basins not advanced were eliminated from consideration based on a variety of reasons, including: infrastructure needs leading to higher costs, small size, water quality issues, liquefaction potential, and institutional complexity.

Table 6-4. Groundwater Basin Candidates Not Advanced

Reservoir	Storage Capacity (acre foot)	Indirect Potable Reuse Potential		Key Considerations
		AFY	mgd	
San Diego Formation 	40,000 to 90,000 (up to 960,000)	0 to 25,000	0 to 22.3	The San Diego Formation is a large basin with good potential. However, additional background information is necessary to develop a project. The City and the United States Geological Survey are currently studying the basin, which will help determine whether this basin would yield beneficial indirect potable reuse projects (which would be considered in future master plans). Other key concerns included seawater intrusion and the heavily developed nature of the overlying coastline near downtown San Diego. The Otay River portion of this basin was also assessed and eliminated from further consideration due to its small size and distance.
Mission Valley 	40,000 to 42,000	0 to 2,000	0 to 1.8	The Mission Valley Basin has certain benefits including simpler institutional issues and an improved ability to get water into and out of the basin. However, it is generally too narrow and too shallow for injection wells. The basin was recently identified as having some connectivity to the San Diego Formation (discussed above). Seawater intrusion, liquefaction potential, localized pollutant plumes, and the highly developed lands overlying the basin were additional considerations. Although the Mission Valley Basin was not considered further for groundwater recharge at this time, it should be considered in future studies.
Tijuana 	50,000 to 80,000	0 to 2,000	0 to 1.8	The Tijuana Basin has some shallow areas (approximately 30 percent of the basin) that may be suitable for indirect potable reuse. However, the basin water quality is compromised by sewage and untreated industrial discharges in the upper layer and salt water intrusion when over-pumped. Extracted water from the basin can be poor quality and would likely require additional treatment in excess of normal conditions. In addition, the basin has extensive riparian vegetation, and extraction of groundwater could have a significant environmental impact on this habitat. These factors and less costly reservoir augmentation choices in South Bay eliminated this basin from further consideration.
San Dieguito 	52,000 to 63,000	1,600 to 10,800	1.4 to 9.6	The upper portion of the San Dieguito Basin may be suitable for groundwater recharge using spreading basins and shallow injection wells. This approach was conceptualized in the 2005 Water Reuse Study. The Olivenhain Municipal Water District has also been studying this basin. The basin is in proximity to a portion of the City's existing non-potable recycled water distribution system. However, substantial infrastructure would still be required. In addition, institutional complexity, community group concerns, liquefaction potential, and limited high value land factored into eliminating this basin from further consideration.
Carmel Valley 	-	-	-	The Carmel Valley Basin is relatively small, and seawater and urban influences may prove challenging. Therefore, this basin was not considered further.

Notes:

- Basin storage capacity derived from Department of Water Resources Bulletin No. 118 and SDCWA Groundwater Report, dated June 1997.
- The San Diego Formation total size has been estimated at 960,000 AF (not including the Sweetwater Basins), but 40,000 to 90,000 AF of storage is considered useable at this time. Ongoing efforts to understand the extents and ability to use this basin will help provide a better foundation for future studies.
- Reuse potential sizing calculated by comparing the candidate basin to the El Monte Groundwater Recharge Project. El Monte Groundwater Recharge Project data based on recent studies provided by Helix Water District. Potential sizing shown based on a six month retention time, consistent with recent regulatory trends.

6.4 Direct Potable Reuse Considerations

Direct potable reuse opportunities were conceptualized during this Study, but were not included as proposed options at this time since they are currently not allowed in California. . The concepts considered during the Study included:

- Conveying purified water from an advanced water purification plant facility at the North City Plant to the Miramar Water Treatment Plant.
- Conveying purified water from an advanced water purification plant facility at the South Bay Plant to the Otay Water Treatment Plant.
- Conveying purified water from an advanced water purification plant facility near Harbor Drive to the Alvarado Water Treatment Plant.

Further development of these concepts will likely occur once there is a framework for how the California Department of Public Health (CDPH) will regulate these projects. While California Senate Bill SB-918 (reference Appendix D) included development of a feasibility study for uniform criteria, the timing and scope of actual requirements will remain unclear until 2016 or later. However, there is continued interest and support being generated for direct potable reuse, such as the January 2012, National Water Resource Institute white paper entitled, *“Direct Potable Reuse: Benefits for Public Water Supplies, Agriculture, the Environment, and Energy Conservation”* (also included in Appendix G). This paper summarizes important benefits and considerations, and cites successful projects in New Mexico and Texas.

Even though the future is unclear for direct potable reuse, the concepts were considered in terms of how they would affect the recommended indirect potable reuse projects in this Study. Potential impacts contemplated included additional treatment processes and monitoring at advanced water purification facilities (added costs) and reduced piping and pumping (cost savings) since deliveries could be made more directly to treatment plants and/or the aqueduct system. Additional considerations are listed in the implementation section of this report.

This page intentionally left blank.



SAN DIEGO RECYCLED WATER STUDY

7. AREA CONCEPTS

Area Concepts were constructed to provide detailed, comparable options for discussion at the Coarse Screening Session and Stakeholder meetings. Area Concepts included non-potable recycled water opportunities from Chapter 5 and indirect potable reuse opportunities from Chapter 6. Area Concepts were developed as the first step in preparing the integrated reuse alternatives discussed later in this Report. Figure 7-1 displays the process of developing opportunities into Area Concepts. Area Concepts were refined at the Fine Screening Session, evaluated according to the Study's goals and project criteria, and then compiled into the Integrated Reuse Alternatives presented in Chapter 8.

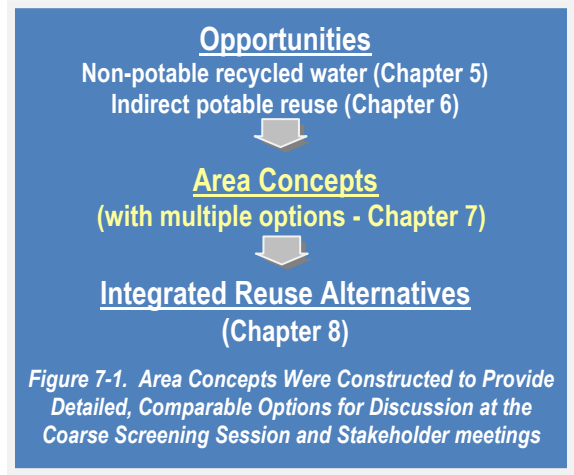

7.1 Area Concept Sub-regions

Area Concepts were organized into three sub-regions within the Metro Service Area, as shown on Figure 7-2. These sub-regions were selected based on: 1) having wastewater available to reclaim in sufficient quantities, 2) being able to expand existing facilities or having land available to build new facilities, and 3) a need for the water produced (non-potable recycled water customers, surface water reservoirs and/or groundwater basins). The three sub-regions included:

- **North City/San Vicente.** The northern portion of the Metro Service Area, which could be served by the North City Plant or a new treatment plant along the Metro System corridor from Mission Valley to Pump Station No. 2 along Harbor Drive.
- **South Bay.** The southern portion of Metro Service Area currently served by the South Bay Plant with the potential to divert additional wastewater from the South Metro Interceptor.
- **Rancho Bernardo/San Pasqual Area.** The northern portion of the Metro Service Area that could be served by a new treatment facility located in Rancho Bernardo adjacent to Pump Station 77.

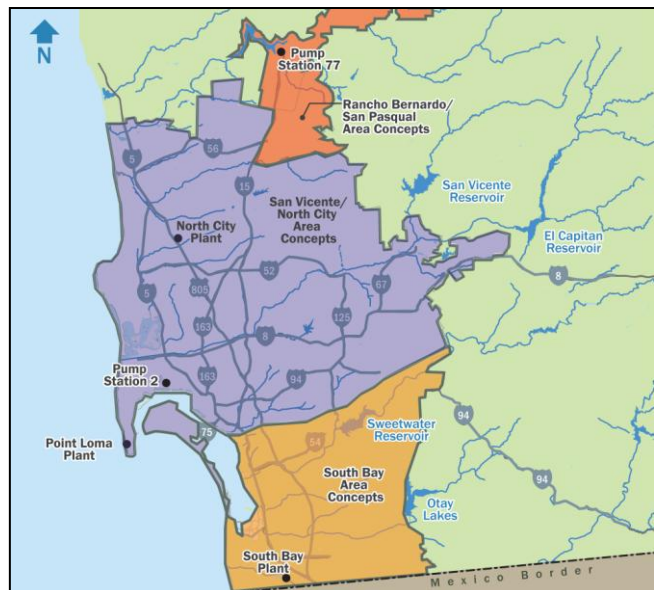

Figure 7-2. Area Concept Sub-regions
Area Concepts were developed for three sub-regions of the Metro System

7.2 Area Concept Background

As noted above, the three Area Concepts involved combining non-potable recycled water opportunities and indirect potable reuse opportunities. Non-potable recycled water opportunities were sized based on the information provided in Chapter 5. Indirect potable reuse opportunities were sized by comparing the available wastewater supplies (summarized in Chapter 4) to the indirect potable reuse capacity potential (summarized in Chapter 6). The Area Concepts were then created by identifying feasible treatment and conveyance facilities. Each Area Concept included three options to provide participants at the Coarse and Fine Screening Sessions the ability to compare the benefits of different approaches within each area. These options were labeled consistently for each Area Concept and were referred to as Option A, Option B, and Option C.



Area Concept Presentations. The Coarse Screening and Fine Screening Sessions included analysis of Area Concepts. Teams studied the opportunities, developed projects, and presented their concepts to the participants.

Capital cost and operation and maintenance costs were developed for each option within each area. Other project costs, including engineering, administration, legal, environmental permitting, construction management, land acquisition, and project contingencies, were also included. The infrastructure layouts and the costs were topics of major discussions at the Coarse and Fine Screening sessions and Stakeholder Status Update Meetings.

Pumping was also an important component in developing the Area Concepts. Pumping affected capital and operational costs and was an important sustainability consideration. Pumping is influenced by physical parameters such as the distance pumped and the elevation difference between the sending and receiving locations. The distance and elevation parameters were established by where wastewater was available and the delivery point for the newly created water (either to non-potable recycled water customers or indirect potable reuse projects using a surface water reservoir or groundwater basin). Pumping is also affected by the flow rates needed to serve the opportunities. Flow rates were affected by the type of water being pumped which varied by option. As water is treated to higher degrees, less of it needs to be pumped since a portion has been removed through the process as waste streams. Considering the type of water pumped as a guideline for how projects should be developed, projects that pumped advanced purified water were preferred over projects that pumped wastewater long distances. The following relates flow rates to the type of water pumped:

- **Advanced Water Purification Facility/Indirect Potable Reuse Water.** Most ideal water to pump within the considered options. Indirect potable reuse water requires pumping approximately 15 percent less flow than pumping tertiary treated water and approximately 28 percent less flow than pumping wastewater.
- **Tertiary Treated Water/Non-potable Recycled Water.** Tertiary treated water requires pumping approximately 15 percent more flow than pumping indirect potable reuse water and approximately 13 percent less flow than pumping wastewater.
- **Wastewater.** Most costly and energy intensive (and difficult to pump from an odor control perspective). Wastewater requires pumping approximately 13 percent more flow than pumping tertiary treated water and approximately 28 percent more flow than pumping indirect potable reuse water. This water has the greatest potential impact if spilled, including adverse environmental impacts.

7.3 Initial North City/San Vicente Area Concepts

The North City/San Vicente Area Concepts played an important role in this Study similar to previous efforts. The 2005 Water Reuse Study affirmed that the San Vicente Reservoir was an ideal location to maximize the use of the treated water produced at the North City Plant through indirect potable reuse. Since the 2005 Water Reuse Study, the San Vicente Reservoir Dam Raise Project has begun. The Dam Raise Project will increase the reservoir storage capacity from approximately 89,000 AF to 241,000 AF and is scheduled for completion in 2013 to 2014. The increased reservoir size and operational flexibility to move water throughout the region keeps San Vicente Reservoir the focal point for advancing water reuse in this area.



San Vicente Dam Raise. The San Vicente Reservoir expansion (architectural rendering shown above) and its integration with regional facilities make it an ideal candidate for indirect potable reuse.

The Coarse Screening Session presented three Area Concepts for the North City/San Vicente Area, as shown on Figure 7-3.

Option A: Morena included a Morena wastewater diversion which pumped additional wastewater to the North City Plant. Option B: Mission Gorge included a new water reclamation facility and advanced water purification plant to supplement indirect potable reuse water from the North City concept. Option C: Mission Valley was similar to the Morena Options, and included a wastewater diversion that pumped additional flows to the North City Plant. The diversions included in Option A and C allowed increasing the capacity of the North City Plant, while Option B evaluated a plant located closest to the planned delivery source. These options were targeted based on their favorable locations along major trunk sewers in the Metro System, which resulted in greater availability of wastewater for reuse.

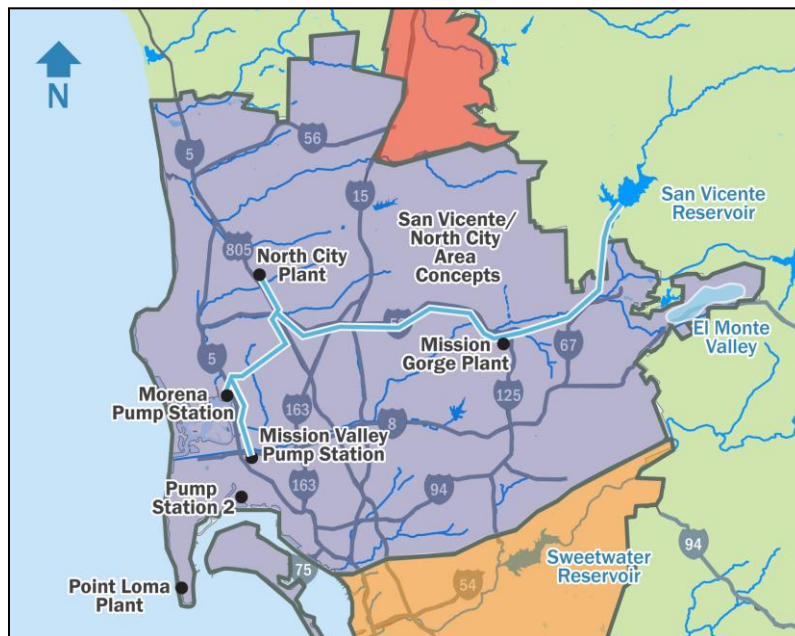

Figure 7-3. Initial North City/San Vicente Area Concepts

Three options were presented at the Coarse Screening Session. The options were later refined to include a new plant closer to Pump Station 2. The El Monte Valley project (by other agencies) was also considered due to its impact on Metro System flows.

The key task for the workshop participants was balancing a variety of considerations for each option. These included: finite existing reclamation capacities and the decision whether to divert new flows to increase capacity; the potential for new treatment plants to increase supplies; the location and capacity of the delivery points for non-potable recycled water (customers) and indirect potable reuse (reservoirs or groundwater basins); costs; environmental benefits; risks; and the ability to implement. The work session participants also considered the effects and timing of the El Monte Groundwater Recharge Project, currently being planned by the Helix Water District and Padre Dam. The El Monte Groundwater Recharge Project is an indirect potable reuse groundwater recharge project that would recharge groundwater supplies in the El Monte Valley in Lakeside, California. This project was considered since it affects the amount of wastewater diverted in the Mission Gorge area just before Padre Dam's Metro System connection. Coarse Screening Session participants agreed that the El Monte Groundwater Recharge Project should be assumed to occur, and it was sequenced with the alternatives developed in the Study.

7.3.1 Coarse Screening Session Conclusions on North City/San Vicente Area Concepts

Coarse Screening Session participants provided valuable input and ideas for the North City/San Vicente Area Concepts. Participants considered numerous permutations of the three core options and discussed the benefits of each. The biggest concern from participants was related to the Mission Valley component (which affected all three options). Pumping larger quantities of wastewater, a long distance to the North City Plant was cited as adding costs and risks. Another concern was that once the master planned capacity of North City was reached at 45 mgd, construction costs increase dramatically since existing facilities would need to be demolished, additional land may be needed, and the construction methods on the new facilities is more expensive due to site constraints. Work session participants suggested modifications to refine the North City/San Vicente Area Concepts for the Fine Screening Session. The revisions provided a new, larger-scale advanced water purification facility located between Mission Valley and Pump Station No. 2 along Harbor Drive.

7.3.2 Modifying the North City/San Vicente Area Concepts

The major refinement stemming from the Coarse Screening Session was changing the Mission Valley diversion that pumped wastewater to the North City Plant into a new advanced water purification facility with water delivered directly to the San Vicente Reservoir. The new plant site was targeted within a corridor, aligned along the North Mission Valley Interceptor in Mission Valley and the North Metro Interceptor ending at Pump Station No. 2 adjacent to the San Diego International Airport. Siting a new large-scale plant is difficult in most locales and even more so in the highly-developed, high-value areas of San Diego, such as this corridor. However, the region's ability to maintain the high quality of life and land values is predicated on having clean, renewable water resources – a need that promotes prudent investments in infrastructure.

7.3.3 Preliminary Siting Evaluation

A preliminary siting assessment was conducted from the east end of the targeted corridor at Qualcomm Stadium to the west end at Pump Station No. 2. At the eastern end of this corridor, the City owns several acres of land at and adjacent to Qualcomm Stadium. A majority of the land in the area is used for stadium activities and parking for trolley passengers. The majority of the remaining City-owned land is located along the San Diego River. The City owns a 17 acre vacant site on the south side of the San Diego River, which is referred to as the Camino Del Rio site. This is the location of the City's former aquaculture recycled water demonstration site that has since been removed. The City has planned for a water reclamation plant at this site for a number of years.

Placing a plant at the west end of the corridor would put its location at a Harbor Drive site located adjacent to the City's Pump Station No. 2 facility. The Harbor Drive site is located at the confluence of the City's two largest interceptor sewers: the North Metro Interceptor and the South Metro Interceptor. At this location, a majority of the wastewater generated by the Metro System collects before being pumped to the Point Loma Plant. The 22 acre site is currently occupied by several agencies (San Diego Fire Rescue Department, San Diego Police Department, San Diego Community College District, and San Diego County Sheriff Department). These agencies have historically indicated their willingness to relocate on the condition that a more suitable site is found.

Since the site is occupied by multiple agencies and recognizing that there are competing uses for this site, the Public Utilities Department engaged in discussions with the San Diego Fire Rescue Department, San Diego Police Department, San Diego Community College District, San Diego County Sheriff Department, San Diego Redevelopment Agency, and the San Diego Real Estate Assets Department. The meetings were conducted to discuss the feasibility of using this site for the purposes described in this Study. The Public Utilities Department initiated the process of determining costs and requirements for relocating the site's current occupants and evaluated alternative sites for the proposed treatment facilities. The siting analysis identified vacant tracks of land with 17 to 23 acres of properly zoned land adjacent to wastewater facilities and available for the proposed facilities. The Harbor Drive site was compared to a site adjacent to wastewater Pump Station No. 1 in National City, Fiesta Island, and Qualcomm Stadium. The siting analysis is included in Appendix E. These other sites proved more expensive and obtrusive than the Harbor Drive site (even without land acquisition costs which were not available for the analysis). Therefore, Harbor Drive was advanced as the targeted site in this Study, along with the existing North City and South Bay Plants and the concept plant at Mission Gorge. Continued siting work is a key implementation step outlined in Chapter 8.

7.3.4 Harbor Drive Site's Strategic Importance

The Harbor Drive site provided substantial benefits and cost savings compared to the locations considered above. The following summarizes the key features unique to this site:

- **Provides Cost Benefits.** The Harbor Drive site provides the following cost benefits:
 - **Facility Cost Savings.** Locating the proposed facilities at the Harbor Drive Site requires the least amount of infrastructure, which reduces capital costs and the operational and maintenance costs related to these additional facilities.
 - **Co-location Savings.** Co-locating the facility adjacent to Pump Station No. 2 and the water quality lab concentrates City staff at a single location and helps increase efficiency and minimize duplicative staffing needs (such as administrative support and security personnel).
 - **Operational Savings.** The ability to efficiently operate year-round (described further below) saves operational costs and maximizes the utilization of the investment.
- **Provides Flexibility.** A majority of the Metro System wastewater flows collect at the Harbor Drive site before being pumped to the Point Loma Plant. This volume of flow, estimated at 105 to 120 mgd (depending on the alternative and amount of reuse completed upstream) provides the following important benefits in regards to operational flexibility:



Related Facilities at the Harbor Drive Site. The Harbor Drive site already accommodates Pump Station No. 2 (the largest wastewater pump station in San Diego) and the Environmental Monitoring and Technical Services Division facility (shown above), which houses the City's water quality laboratory. Co-locating a new plant at this site saves costs, increases flexibility and reduces risks.

- **Efficient, Base-loaded Operation.** The amount of wastewater at the proposed Harbor Drive Plant would allow the advanced water purification facility to operate at a consistent flow year-round. Plants with constant output are more efficient to operate saving costs.
- **Ability to Peak During High Demands.** The excess amount of wastewater to treat at Harbor Drive site would allow the plant to treat and produce even higher advanced purified water flows during the summer. Although this is not as efficient as the baseline operation described above, it could provide more water to local drinking water treatment plants when demands are highest. Indirect potable reuse output at the North City, South Bay and Mission Gorge Plants is limited by the amount of wastewater available and the occurrence of peak summer non-potable recycled water demands.
- **Flexibility to Meet Future Needs.** This location, with its converging high flow wastewater pipelines, provides excess wastewater that would allow future expansion of advanced water purification facilities (if desired). This provides flexibility to adapt to direct potable reuse opportunities (pending regulatory changes) and other groundwater opportunities (including the nearby San Diego Formation) that may prove feasible in future planning updates.
- **Maximizes Use of Existing Assets.** The Harbor Drive site allows disposal of brine to the Point Loma Plant by using the existing Pump Station No. 2 facility, which would be adjacent to the plant.
- **Reduces Risk.** The Harbor Drive site minimizes risk through the following benefits:
 - **Consolidation of Odor Control.** The need for odor control is consolidated to an existing impacted site (the Harbor Drive site adjacent to Pump Station No. 2) rather than at two locations (Pump Station No. 2 and an alternative site).
 - **Reduced Wastewater Pumping.** This site limits the risks and added pumping costs associated with conveying wastewater across the City to an alternative plant location and conveying waste streams back to Pump Station No. 2.

7.3.5 Harbor Drive Facility Options to Minimize Site Needs

The revised North City/San Vicente Area Concepts considered ways to limit or reduce the area needed for the Harbor Drive Plant facilities (its footprint) at the Harbor Drive site recognizing that it may be limited and has multiple City uses proposed. Two approaches were considered:

- **Split Plant.** To lessen the footprint needed at the Harbor Drive site, options were developed that located the water reclamation portion of the plant at Harbor Drive to treat wastewater to non-potable tertiary levels and located the advanced water purification facility processes to generate indirect potable reuse water at the Camino Del Rio site in Mission Valley. This approach does not receive the same economy of scale cost benefits from having the treatment facilities combined; but, it does limit the siting needs at both sites should future detailed siting studies identify constraints or costly construction impacts. The revised Area Concepts described below that use this approach are labeled as Theme A1 and Theme B1.
- **Consolidated Plant.** The second approach to lessen the facility footprint was to build all the treatment processes at Harbor Drive. The footprint is consolidated by eliminating the redundant facilities needed at two separate locations (such as administration and security elements). Therefore a consolidated approach provides a more efficient approach and lower operational costs compared to split plants. However, construction costs may be higher depending on final needs, sizing, and land availability (which may require more vertical construction methods to fit plant components in a smaller footprint). The revised Area Concepts described below that use this approach are labeled as Theme A2, Theme B2, and Theme B3.

7.4 Revised North City/San Vicente Area Concepts

Due to the emerging importance of the Harbor Drive site and the additional flows available at this site, the North City/San Vicente Area Concepts were revised to increase overall water reuse. A multi-phase approach was used to develop a minimum of 65 mgd of advanced treated water for indirect potable reuse (the reuse target is described further in Chapter 8). These totals are in addition to existing and planned non-potable recycled water flows at the North City Plant. The North City Area Concepts were developed into two major themes to reach this goal, each having sub-themes that differ according to whether the Harbor Drive facility would be split between the Harbor Drive and Camino Del Rio sites, or be consolidated at the Harbor Drive site. Figure 7-4 summarizes the projects and sequential steps of the A and B Themes (Chapter 8 includes additional details on the numbering system used to define these Area Concepts).

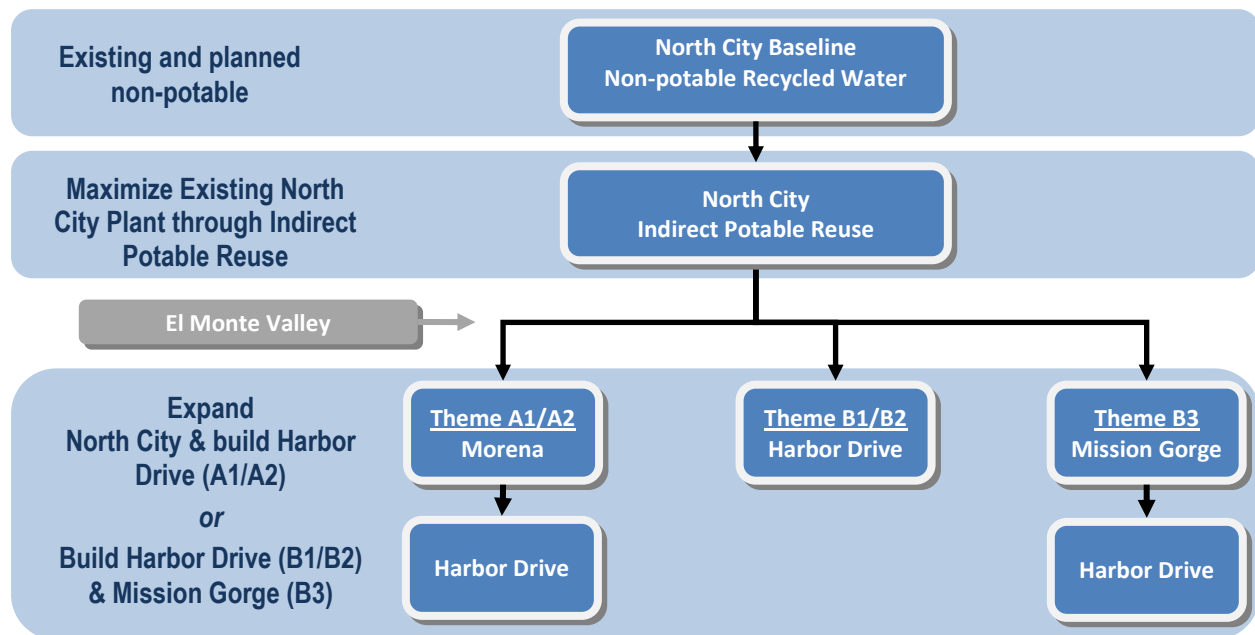

Figure 7-4. Refined North City/San Vicente Area Concepts

The Area Concept themes are summarized as follows. Table 7-1 summarizes the elements included in each Area Concept Theme.

- North City/San Vicente Theme A – Maximize the North City Plant Master-Planned Capacity of 45 mgd.** The North City Plant was master planned to expand from its existing 30 mgd capacity to 45 mgd. Option A (from the initial Area Concepts summarized above) consists of a diversion at Morena that diverts enough flow to the North City Plant to meet this master-planned treatment capacity of 45 mgd (reference Chapter 4 for inflows into the plant). The diverted flows allow serving existing and planned non-potable recycled water demands amounting to 9.1 mgd, an initial indirect potable reuse project sized at 15.0 mgd, and a second phase indirect potable reuse project sized at 11.9 mgd. The indirect potable reuse projects include water deliveries to the San Vicente Reservoir. The 40.9 mgd remainder of the water reuse target is met by a Harbor Drive Plant and indirect potable reuse project to the San Vicente Reservoir. The Harbor Drive Plant is smaller for the A Themes, since more flows are treated at the North City Plant.

- North City/San Vicente Theme B – Maximize the North City Plant Existing Capacity of 30 mgd.**
 The B Themes were developed to take advantage of the strategic importance of the Harbor Drive site including the ability to maximize the economy of scale of a larger, consolidated plant at this location. The B Themes maximize the existing North City Plant capacity of 30 mgd by serving existing and planned non-potable demands of 9.1 mgd and a North City indirect potable reuse project sized at 15mgd (similar to the A Themes). The difference with the B Themes is that no further diversions occur to the North City Plant. The remainder of the water reuse target is met by a 52.8 mgd Harbor Drive Plant and indirect potable reuse project to the San Vicente Reservoir (Theme B2), or a combination of a 46.0 mgd Harbor Drive Plant and a 6.8 mgd Mission Gorge Plant (Theme B3).

Table 7-1. North City/San Vicente Area Concept Summary – Included Elements

Elements in the Area Concept	A1	A2	B1	B2	B3
Add more Existing non-potable recycled water	✓	✓	✓	✓	✓
Planned non-potable recycled water (through 2015)	✓	✓	✓	✓	✓
Maximize the North City Plant to its 45 mgd master planned capacity	✓	✓			
Maximize the North City Plant to its existing 30 mgd capacity			✓	✓	✓
Initial North City indirect potable reuse to San Vicente	✓	✓	✓	✓	✓
North City expansion using the Morena Diversion with indirect potable reuse to San Vicente	✓	✓			
Harbor Drive Plant with indirect potable reuse water deliveries to San Vicente Reservoir	✓	✓	✓	✓	✓
Harbor Drive consolidated Water Reclamation Plant/Advanced Water Purification Facilities (WRP/AWPF)		✓		✓	✓
Harbor Drive WRP/Camino Del Rio AWPF split plant	✓		✓		
Mission Gorge indirect potable reuse to San Vicente					✓

Table 7-2 includes the flows associated with each element and the overall offload at the Point Loma Plant.

Table 7-2. North City/San Vicente Area Concept Summary – 2035 Dry Weather Flows							
Theme	Harbor Drive AWPf Location	North City Non-potable Recycled Water (mgd)	Indirect Potable Reuse Water (mgd)			Offloading (mgd)	
			North City	Harbor Drive	Mission Gorge	New Facilities	New & Existing Facilities
A1	Camino Del Rio (Mission Valley)	9.1	26.9	40.9	0	67.8	76.9
A2	Harbor Drive	9.1	26.9	40.9	0	67.8	76.9
B1	Camino Del Rio (Mission Valley)	9.1	15.0	52.8	0	67.8	76.9
B2	Harbor Drive	9.1	15.0	52.8	0	67.8	76.9
B3	Harbor Drive	9.1	15.0	46.0	6.8	67.8	76.9

Notes:

- Reuse totals shown are average annual values. The Study analysis also accounted for seasonal influences. See Figure 5-4.
- Point Loma Plant offloads are for 2035 Dry Weather Conditions and are calculated both with and without North City non-potable recycled water flows. The financial analysis included costs and benefits only for the new facilities identified in this Study. Non-potable reuse offloading is also not included during 2050 wet weather events for estimating direct and indirect wastewater systems savings (see Chapter 8 and Appendix H for further details).
- The flows shown are 2035 projections. All proposed plants have startup dates between 2020 and 2035. Startup prior to 2035 will have lower flows initially; however, the interim flows are projected to be 90- to 95-percent of the 2035 flows (reference Table 4-2).
- The El Monte Groundwater Recharge Project plans to inject 5 mgd of IPR water into the El Monte Valley groundwater basin. The El Monte project is currently on hold, but Padre Dam and Helix Water District continue to plan for this or a similar indirect potable reuse project. While the flows for this project are not shown in the table above, they were accounted for and coordinated with Reuse Projects in this Study.

Table 7-3 summarizes the type of water being pumped for each theme. In general, the B Themes had the least pumping requirements since they maximized pumping high quality advanced purified water that already had waste streams removed.

Table 7-3. North City/San Vicente Area Concept Summary – Pumping	
Area Concept and Key Differentiator	Type of Water Pumped
A1 Morena Diversion to North City Harbor Drive WRP with AWPf at Camino Del Rio	Wastewater Tertiary Water (for non-potable demands) Advanced Purified Water (for indirect potable reuse)
A2 Morena Pump Diversion to North City	Wastewater Advanced Purified Water (for indirect potable reuse)
B1 Larger Harbor Drive WRP with AWPf at Camino Del Rio	Tertiary Water (for non-potable demands) Advanced Purified Water (for indirect potable reuse)
B2 Larger Harbor Drive WRP/AWPf	Advanced Purified Water (for indirect potable reuse)
B3 Larger Harbor Drive WRP/AWPf Mission Gorge WRP/AWPf	Advanced Purified Water (for indirect potable reuse)

7.4.1 North City/San Vicente Themes A1 and A2

The A Themes were developed to maximize the 45-mgd master-planned treatment capacity potential at the North City Plant. The key aspects of these approaches are summarized below.

Theme A1

Theme A1, displayed in Figure 7-5, includes the following key elements:

- Serves existing non-potable demands.
- Serves planned non-potable demands that increase through 2015.
- Maximizes the master-planned tertiary capacity at North City Plant at 45 mgd.
- Includes a North City Advanced Water Purification Facility to produce indirect potable reuse water and deliver it to the San Vicente Reservoir.
- Includes a North City Water Reclamation Plant/Advanced Water Purification Facility expansion to increase indirect potable reuse flows to the San Vicente Reservoir (via diverted wastewater from the Morena Pump Station).
- Includes a Harbor Drive Water Reclamation Plant (tertiary plant).
- Locates the Harbor Drive Advanced Water Purification Facility at Camino Del Rio (Mission Valley) to reduce space requirements at the Harbor Drive site. This facility would produce indirect potable reuse water for delivery to the San Vicente Reservoir.
- Requires two brine lines to avoid re-circulating high salinity brine discharges.

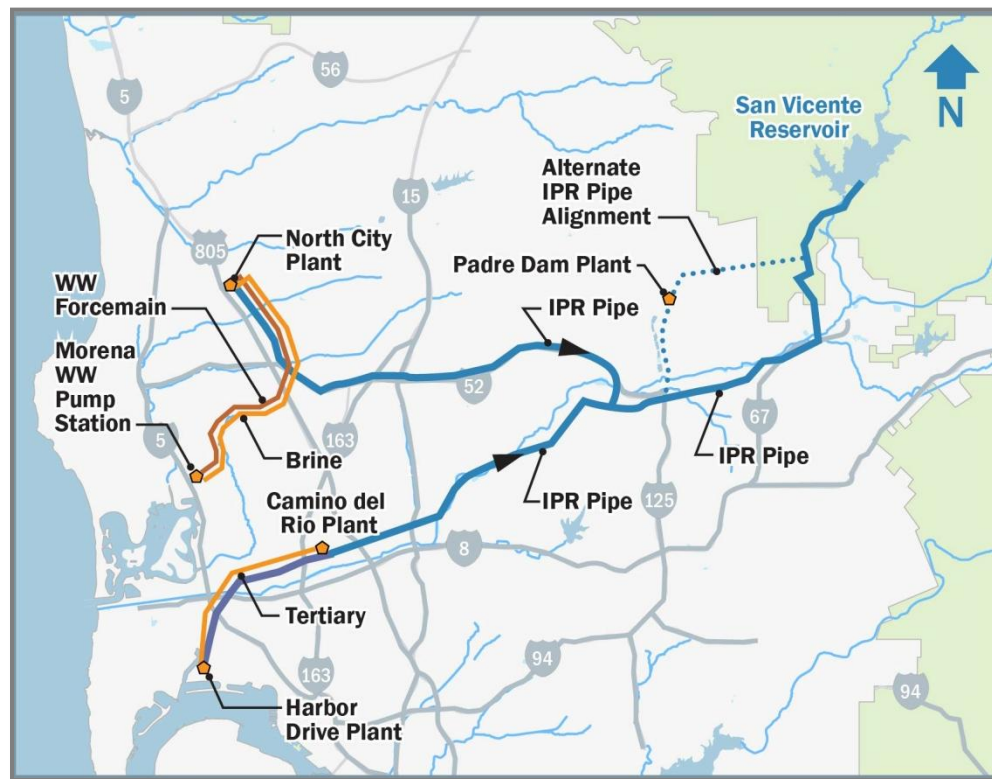

Figure 7-5. Schematic of Theme A1

Theme A2

Theme A2, displayed in Figure 7-6, includes the following key elements:

- Serves existing non-potable demands.
- Serves planned non-potable demands that increase through 2015.
- Maximizes the master-planned tertiary capacity at North City Plant at 45 mgd.
- Includes a North City Advanced Water Purification Facility to produce indirect potable reuse water and deliver it to the San Vicente Reservoir.
- Includes a North City Water Reclamation Plant/Advanced Water Purification Facility expansion to increase indirect potable reuse flows to the San Vicente Reservoir (via diverted wastewater from the Morena Pump Station).
- Includes a Harbor Drive Water Reclamation Plant (tertiary plant) and co-located Advanced Water Purification Facility (indirect potable reuse plant). This facility would produce indirect potable reuse water for delivery to the San Vicente Reservoir.
- Requires a brine lines to avoid re-circulating high salinity brine discharges.

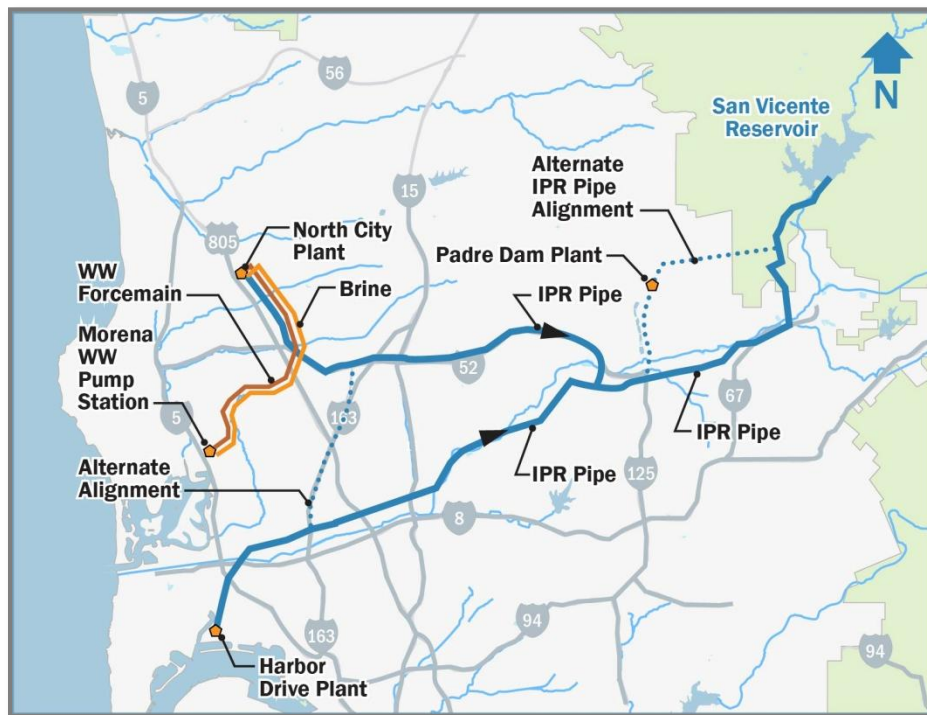

Figure 7-6. Schematic of Theme A2

7.4.2 North City/San Vicente Themes B1, B2 and B3

The B Themes were developed to maximize the existing treatment capacity of 30 mgd at the North City Plant. The key aspects of these approaches are summarized below.

Theme B1

Theme B1, displayed in Figure 7-7, includes the following key elements:

- Serves existing non-potable demands.
- Serves planned non-potable demands that increase through 2015.
- Maximizes the existing tertiary capacity at North City Plant at 30 mgd.
- Includes a North City Advanced Water Purification Facility to produce indirect potable reuse water and deliver it to the San Vicente Reservoir.
- Includes a Harbor Drive Water Reclamation Plant (tertiary plant).
- Locates the Harbor Drive Advanced Water Purification Facility at Camino Del Rio to reduce space requirements at the Harbor Drive site. This facility would produce indirect potable reuse water for delivery to the San Vicente Reservoir.
- Requires a brine lines to avoid re-circulating high salinity brine discharges.

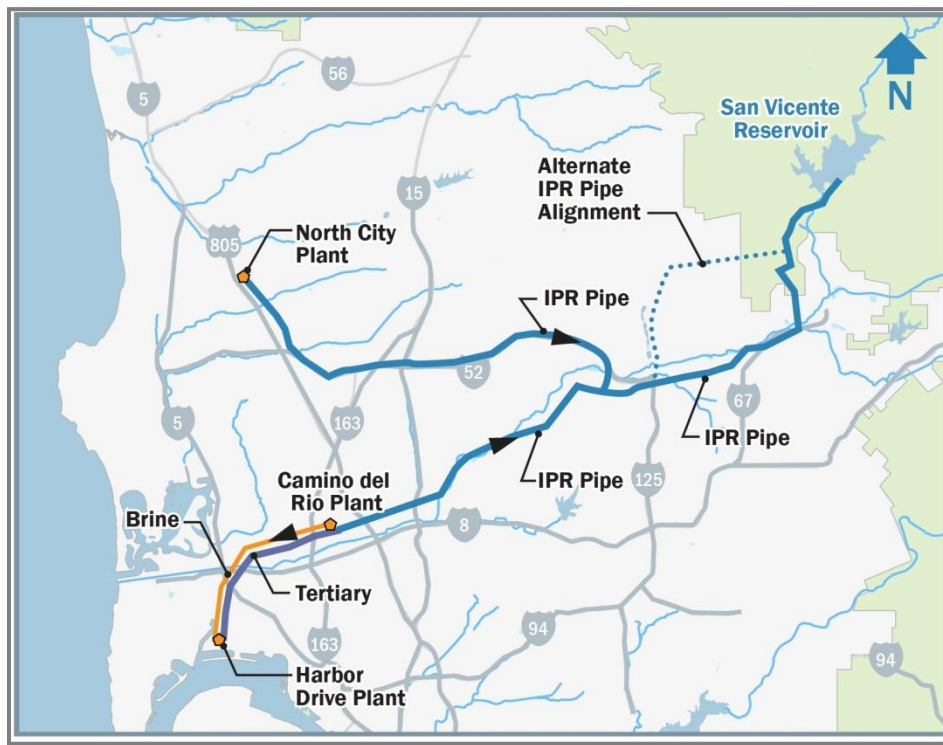

Figure 7-7. Schematic of Theme B1

Theme B2

Theme B2, displayed in Figure 7-8, includes the following key elements:

- Serves existing non-potable demands.
- Serves planned non-potable demands that increase through 2015.
- Maximizes the existing tertiary capacity at North City Plant at 30 mgd.
- Includes a North City Advanced Water Purification Facility to produce indirect potable reuse water and deliver it to the San Vicente Reservoir.
- Includes a Harbor Drive Water Reclamation Plant (tertiary plant) and co-located Advanced Water Purification Facility (indirect potable reuse plant). This facility would produce indirect potable reuse water for delivery to the San Vicente Reservoir.

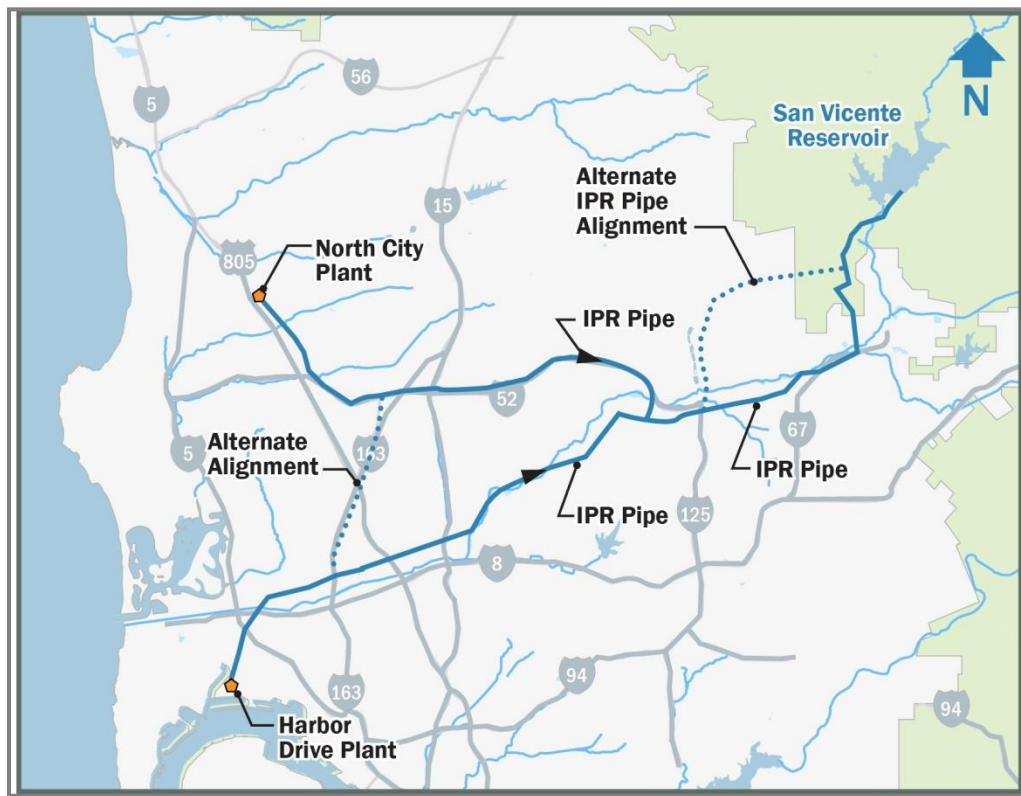

Figure 7-8. Schematic of Theme B2

Theme B3

Theme B3, displayed in Figure 7-9, includes the following key elements:

- Serves existing non-potable demands.
- Serves planned non-potable demands that increase through 2015.
- Maximizes the existing tertiary capacity at North City Plant at 30 mgd.
- Includes a North City Advanced Water Purification Facility to produce indirect potable reuse water and deliver it to the San Vicente Reservoir.
- Includes a Harbor Drive Water Reclamation Plant (tertiary plant) and co-located Advanced Water Purification Facility (indirect potable reuse plant). This facility produces indirect potable reuse water for delivery to the San Vicente Reservoir.
- Includes a Mission Gorge Water Reclamation Plant (tertiary plant) and co-located Advanced Water Purification Facility (indirect potable reuse plant). This facility would produce indirect potable reuse water for delivery to the San Vicente Reservoir.

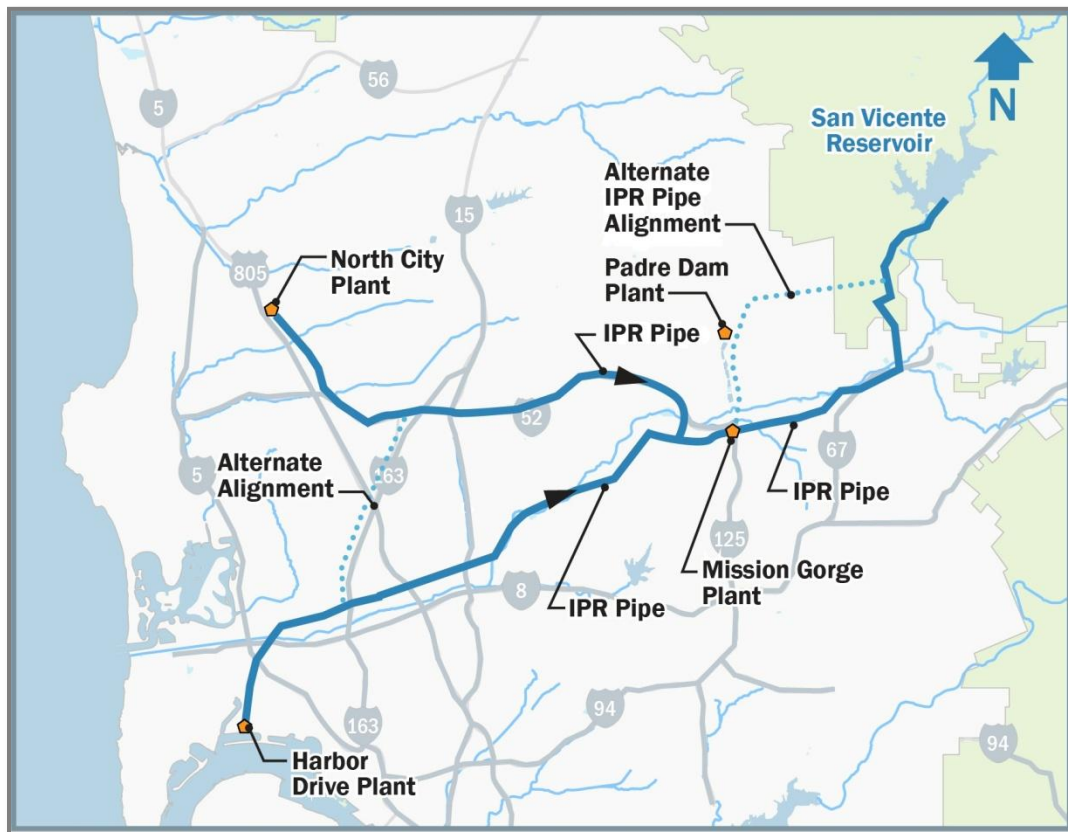

Figure 7-9. Schematic of Theme B3

Note: The Mission Gorge Plant may be co-located with the Padre Dam Plant. A siting study would be required to determine the most appropriate location.

7.5 South Bay Area Concepts

Similar to the original North City/San Vicente Area Concepts, the South Bay Area Concepts also included three options. The alternatives were titled South Bay Option A, Option B and Option C. Each option included baseline non-potable recycled water demands for South Bay (as described in Chapter 5). These baseline non-potable recycled water demands included existing flows at the South Bay Plant, planned flows through 2015 for City retail customers, and 2026 contracted flows with Otay. Each option then provided differing non-potable recycled water and indirect potable reuse approaches. The Options were presented at the Coarse Screening Session and are summarized in Figure 7-10 and Table 7-4. An additional Option, labeled C2 and also shown below, was added based on feedback at the Coarse Screening Session to consider diverting additional wastewater to the South Bay Plant. South Bay Option C2 played an important role in shaping the Integrated Reuse Alternatives as this option was included in all of the final Integrated Reuse Alternatives described in Chapter 8. Figure 7-11 displays the facilities included in this Option.

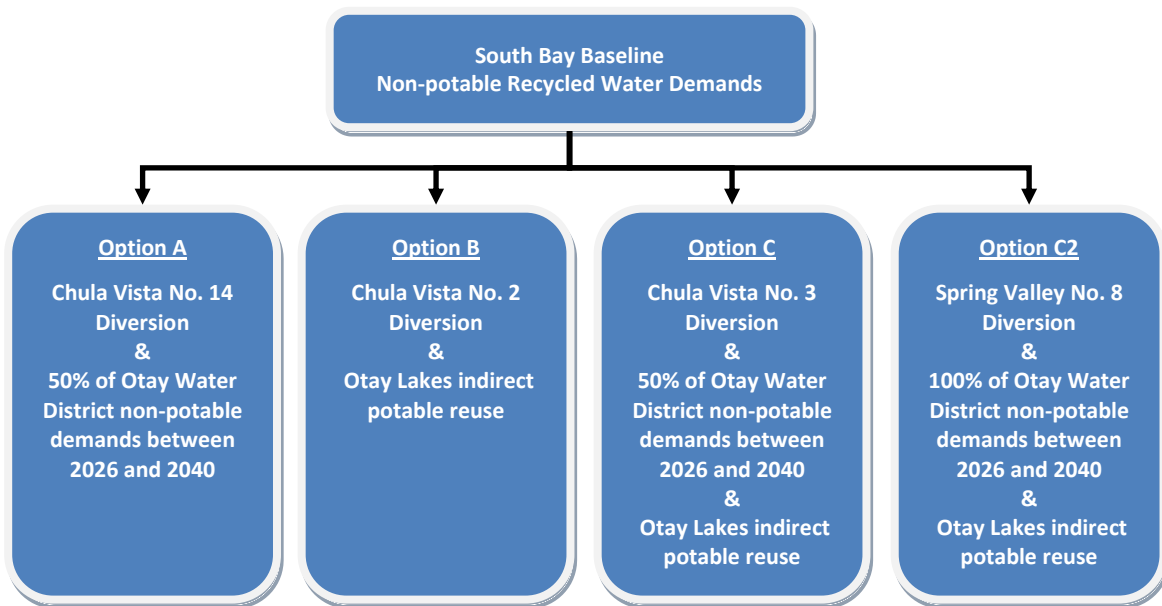

Figure 7-10. Schematic of South Bay Options

Table 7-4 summarizes the elements included in each Area Concept.

Table 7-4. South Bay Area Concepts Summary – Included Elements				
Elements in the Area Concept	A	B	C	C2
Existing non-potable recycled water	✓	✓	✓	✓
Planned non-potable recycled water (2015 City/2026 OWD)	✓	✓	✓	✓
Future non-potable recycled water (1.5 mgd for OWD)	✓		✓	
Future non-potable recycled water (3.0 mgd for OWD)				✓
Diversion to South Bay	CV14	CV2	CV3	SV8
South Bay indirect potable reuse to Otay Lakes		✓	✓	✓

Notes: Acronyms used in this table include: OWD = Otay Water District; CV = Chula Vista; SV = Spring Valley.



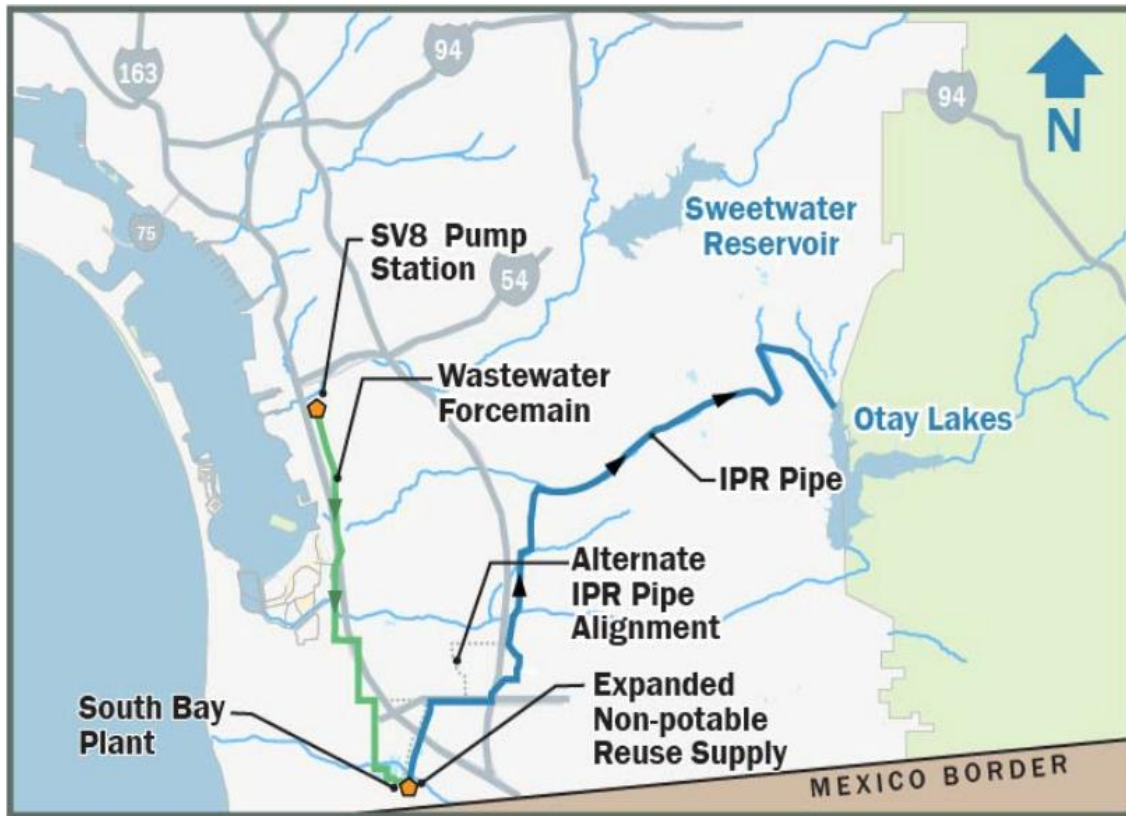

Figure 7-11. South Bay C2 Area Concept

The South Bay C2 Area Concept was advanced to the Integrated Reuse Alternatives described in Chapter 8. The South Bay configuration will ultimately need to be coordinated with the City's September 2011 Draft Wastewater Master Plan, also described in Chapter 8.

7.5.1 South Bay Wastewater Diversions

A key consideration for the South Bay system was determining how much flow needs to be diverted to provide wastewater for the various South Bay Area Concepts. By 2035, the Grove Avenue Pump Station is projected to convey approximately 12.9 mgd of wastewater to the South Bay Plant (Dry Weather Flow). This is not enough to serve the opportunities identified for this area. Additionally, new diversions are needed to increase water reuse in South Bay and further offload the Point Loma Plant in coordination with the City's September 2011 Draft Wastewater Master Plan.

Flow diversions to South Bay have been studied and planned by the City for some time. Interim diversions are also being discussed by the City, Otay, and the City of Chula Vista (Chula Vista). The South Metro Interceptor conveys wastewater northward through Chula Vista and National City toward the Point Loma Plant. Several potential diversion locations generally correspond to where Participating Agency trunk sewers connect to the South Metro Interceptor. Table 7-5 includes the flows available at specific metered locations and the estimated equivalent tertiary treated water (non-potable recycled water) after treatment losses. Figure 7-12 provides a schematic representation of the potential diversion points and flows.

Table 7-5. Wastewater and Tertiary Water Availability in 2035 for South Bay

Tributary Sewer	Wastewater Diversion to South Bay (mgd)		Tertiary Water Available for IPR and Non-potable Reuse (mgd)
	Potential	Cumulative	
Grove Avenue Pump Station (Existing)	12.9	12.9	11.0
Imperial Beach/Palm City	3.8	16.7	14.2
Salt Creek Trunk Sewer CV14	6.2	22.9	19.5
Chula Vista CV2	5.0	27.9	23.8
Chula Vista CV3	2.1	30.0	25.7
Spring Valley Trunk Sewer SV8	14.0	44.0	37.6

Note: Totals shown are annual averages. Wastewater flows based on SANDAG Series 12, with reduced unit generation rates and dry weather conditions. Flows prior to 2035 are lower per Table 4-3. Available tertiary water is after treatment losses of approximately 13 percent.

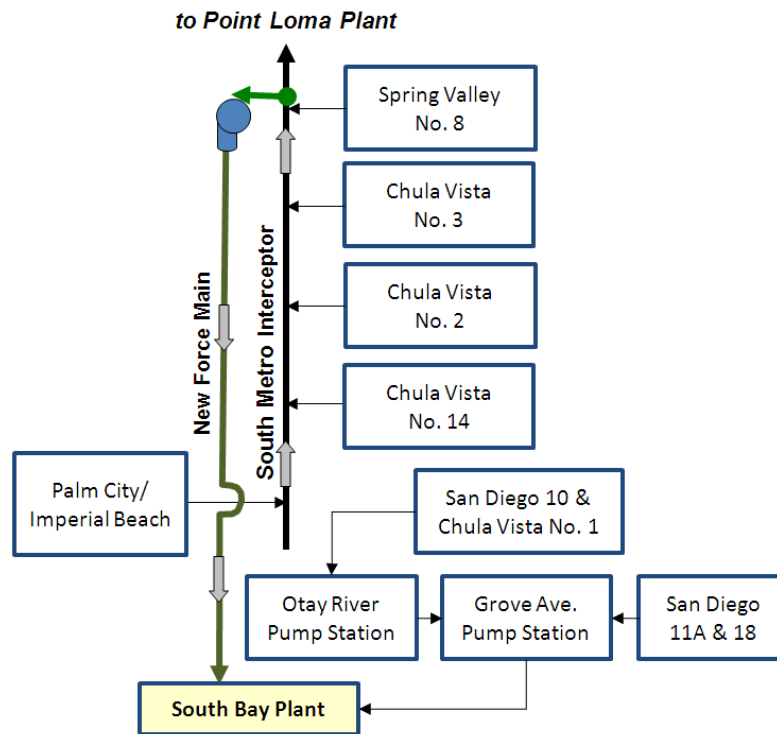

Figure 7-12. South Bay Wastewater Diversions

Different diversion points were considered to redirect wastewater to the South Bay Plant. Although moving the diversion point north increases infrastructure costs, the additional flow increases water reuse opportunities and creates a valuable new water resource.

7.5.2 South Bay Area Concepts Flow Summary

Table 7-6 summarizes the non-potable recycled water and the indirect potable reuse water produced for each of the area concepts.

Option	Tributary Sewer and Point of Diversion	Average Annual Reuse (mgd)	
		Non-potable Recycled Water	Indirect Potable Reuse
South Bay A	Chula Vista No. 14	7.5	0.0
South Bay B	Chula Vista No. 2	6.0	14.5
South Bay C	Chula Vista No. 3	7.5	14.5
South Bay C2	Spring Valley No. 8	9.0	15.0

Notes:

- Reuse totals shown are average annual demands. The Study analysis also accounted for seasonal influences. See Figure 5-5.
- Point Loma Plant 2035 offloads are calculated both with and without the existing Grove Avenue Pump Station. The financial analysis included avoided cost benefits, but only for new facilities identified in this Study.

7.5.3 Wet Weather Flow Considerations at South Bay

South Bay was considered for further utilization since it has an outfall with available capacity. The concept sizing presented above is based on 2035 Dry Weather Flows, which is appropriate since these are the reliable wastewater supplies that can be depended upon throughout the year for reuse purposes. However, the South Bay Plant sizing is also influenced by the overall wastewater disposal strategy during peak wet weather events. Appendix H summarizes how the concepts presented above were compared to the City's September 2011 Draft Wastewater Master Plan disposal strategy and its critical flow criteria of 2050 Peak Wet Weather Flows, including a 10-year return event.

7.6 Rancho Bernardo/San Pasqual Area Concepts

Three Rancho Bernardo/San Pasqual Area Concepts were presented at the Coarse Screening Session. These Area Concepts include a new water reclamation plant located adjacent to Pump Station 77. Pump Station 77 currently pumps City wastewater to the City of Escondido Hale Avenue Resource Recovery Facility (Hale Avenue Plant). The contracted flow from Pump Station 77 to the Hale Avenue Plant is 5.3 mgd. Building a new treatment facility at Pump Station 77 would allow reusing this water for non-potable recycled water demands at nearby golf courses and landscaping, or for a new indirect potable reuse in the San Pasqual Groundwater Basin or downstream at Lake Hodges. The Rancho Bernardo/San Pasqual Area Concepts are relatively small compared to the other Area Concepts considered in the Study and do not offload flows from the Point Loma Plant.

7.6.1 Rancho Bernardo/San Pasqual Area Concept Options

Three options were developed for the Rancho Bernardo/San Pasqual Area Concepts. These options are summarized in Figure 7-13 and were presented at the Coarse Screening Session. The following summarizes the options:

- **Rancho Bernardo/San Pasqual Option A: Rancho Bernardo/I-15 Corridor Non-potable.** Option A included serving non-potable recycled water opportunities identified in the City’s Rancho Bernardo area and the northern portion of the City of Poway. This area includes multiple golf courses. Option A did not include an indirect potable reuse project.
- **Rancho Bernardo/San Pasqual Option B: San Pasqual Indirect Potable Reuse.** San Pasqual Option B included developing an indirect potable reuse project that used the lower San Pasqual groundwater basin. Water would be either recharged or injected at the easterly end of the lower basin and extracted at the west end of the basin just upstream of Lake Hodges. The extracted water would be treated and then delivered to the City’s potable water system at the Rancho Bernardo Reservoir. This option did not include serving non-potable reuse demands.
- **Rancho Bernardo/San Pasqual Option C: San Pasqual Indirect Potable Reuse.** San Pasqual Option C was an alternative to Option B. It included an indirect potable reuse project that recharged/injected advance purified water into the lower San Pasqual basin. The difference between Options B and C is that Option C allowed the recharge water to supply Lake Hodges, which could then be extracted through the Olivenhain Dam Pump Storage project and transferred through the San Diego County Water Authority untreated water conveyance system to the City of San Diego and other water agencies.

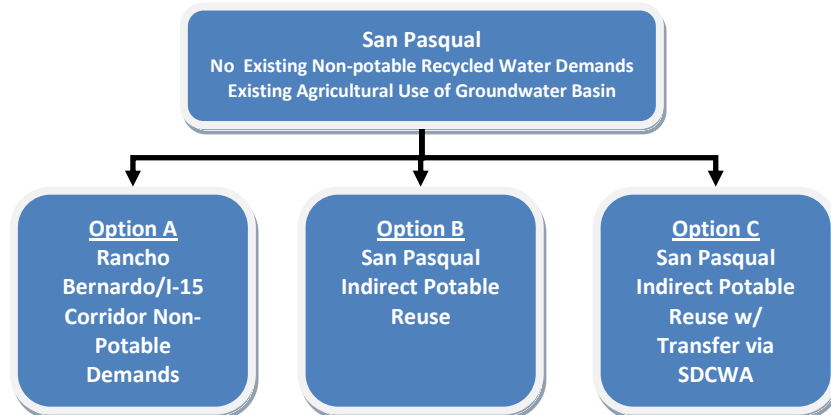

Figure 7-13. Schematic of Rancho Bernardo/San Pasqual Area Concepts.

7.6.2 Rancho Bernardo/San Pasqual Area Concept Conclusions

The Rancho Bernardo/San Pasqual options presented at the Coarse Screening Session are shown on Figures 7-14 through 7-16. The participants concluded that the Rancho Bernardo/San Pasqual Area Concepts provided limited benefits compared to the North City and South Bay Area Concepts. The Rancho Bernardo/San Pasqual Area Concepts did not offload flows to the Point Loma Plant (a major Study goal), provided limited water supply benefits, and were more costly. Therefore, these Area Concepts were not advanced to the Coarse Screening Session. However, it was recognized that the area has substantial non-potable recycled water demand and that a project similar to Option A should be considered for a development offset project, or a privately funded project led by the benefitting customers.

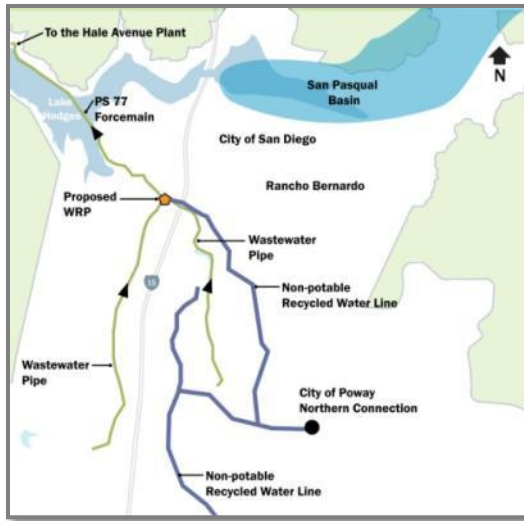

Figure 7-14. Rancho Bernardo/San Pasqual Option A

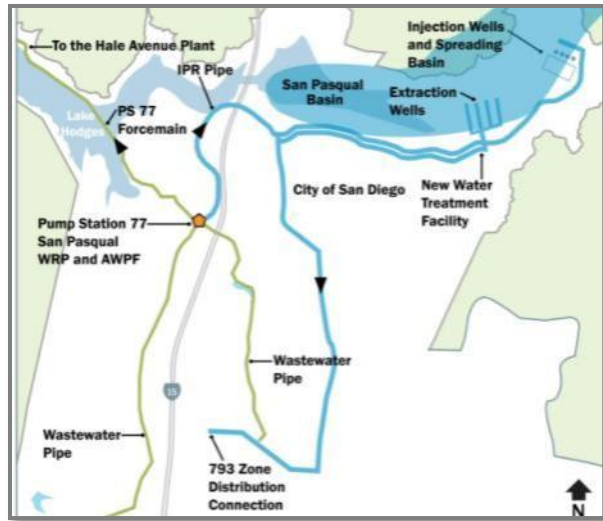

Figure 7-15. Rancho Bernardo/San Pasqual Option B

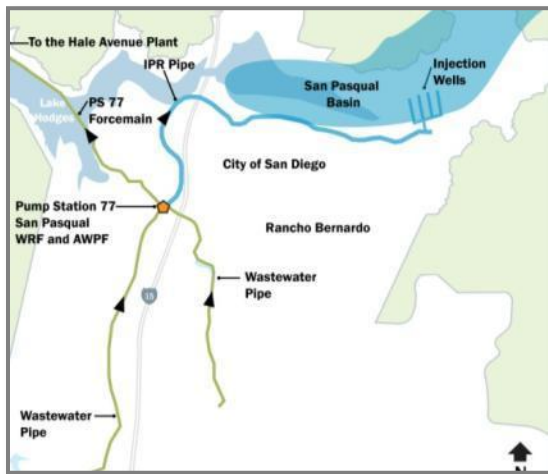

Figure 7-16. Schematic of Rancho Bernardo/San Pasqual Option C

Figures 7-14 through 7-16. Rancho Bernardo/San Pasqual Area Concepts. The Rancho Bernardo/San Pasqual Area Concepts were smaller in scale than other reuse options, did not offload flows to the Point Loma Plant, and the indirect potable reuse projects would be institutionally complex to implement. However, non-potable recycled water Option A was identified as a possible development offset project or a candidate for private funding.

7.7 Area Concept Conclusions

The Stakeholder group and the work session participants agreed that the Area Concepts provided appropriate project elements for further refinement in the Fine Screening Session, and ultimately into the Integrated Reuse Alternatives presented in this Report.

8. INTEGRATED REUSE ALTERNATIVES

Integrated Reuse Alternatives were prepared for policy makers to review, examine, and debate as part of establishing the course for water reuse in the region. The Integrated Reuse Alternatives were compiled from the foundational elements summarized in previous chapters, as shown on Figure 8-1. Integrated Reuse Alternatives were based on the project goals established by the project Stakeholders, the criteria developed at the Framework Planning Session, the screening work performed at the Coarse Screening Session, and the revision and refinement steps performed at the Fine Screening Session and subsequent Stakeholder Status Update Meetings. This chapter first summarizes the water reuse target that influenced these approaches and then summarizes each approach, benefits, considerations, costs, and key implementation steps.

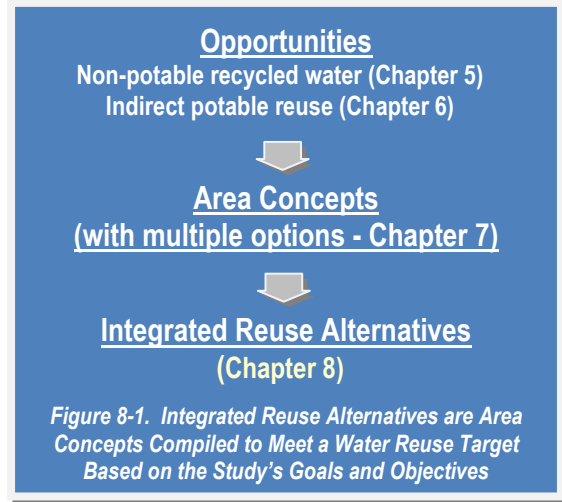

8.1 Establishing the Study's Water Reuse Target

The size and scope of the projects included in the Integrated Reuse Alternatives were selected to achieve a water reuse target. The water reuse target used in the work sessions and used in the Stakeholder Status Update Meetings was approximately 100 mgd. The following summarizes the considerations that led to developing this water reuse target and the confirmation step that involved a comparison to the City's September 2011 Draft Wastewater Master Plan.

8.1.1 Previous and Current Study Target Basis

The water reuse target, similar to past efforts, was based on Study goals, Stakeholders' input, and findings from preliminary technical analyses. The goal of the 2005 Water Reuse Study was to maximize the available capacities at the North City and South Bay Plants, which coincided with a target of approximately 20 mgd for future water reuse projects. This 2012 Study was initiated with a broader basis: to consider the water reuse goal to be limited *only* by the amount of wastewater available in the Metro Service Area. This is a more comprehensive goal, providing the potential to reuse ten times more water than previous targets.

8.1.2 Water Supply Considerations for the Water Reuse Target

As highlighted in Chapter 2, multiple forces are driving water reuse in Southern California. Water reuse projects produce high-quality, reliable, uninterrupted local water to the region, serving the same purpose as imported untreated water. Imported untreated water rates will continue to rise, and the San Diego County Water Authority may have to build new conveyance system improvements to deliver more imported water to the region's drinking water treatment plants—unless the supply is supplemented with new local supplies. Indirect potable reuse can fulfill this need and over time do so at lower costs. Based on these considerations, the reuse target for this study, especially the indirect potable reuse portion, should be maximized.

8.1.3 Water Quality Considerations for the Water Reuse Target

Two water quality considerations were taken into account in establishing a water reuse target: ocean water quality and imported water salinity. Both are important, and both would be significantly improved through implementation of the water reuse projects identified in this Study. For example, blending advanced purified water with imported water in San Vicente Reservoir and Otay Lakes could reduce salinity levels by 50 percent. Ocean water quality would also improve by removing and diverting solids to the Metropolitan Biosolids Center. On land, the reservoirs that receive the advanced purified water, the residents that use the water, and the soil that is irrigated with the water would benefit from having water with up to half the current salinity levels. Residents would benefit from softer water through extended lives of household appliances such as water heaters, dishwashers, clothes washers and faucets. Based on these considerations, the water reuse target for this Study should be maximized.

8.1.4 Project Size Considerations for the Water Reuse Target

Project sizing (summarized in Chapter 5 for non-potable recycled water opportunities and Chapter 6 for indirect potable reuse opportunities) was considered a limiting factor in developing the water reuse target. Non-potable recycled water projects, while beneficial for targeted areas (such as Otay Water District's planned system expansion), did not have enough demand potential to use a substantial portion of the available wastewater. It also became apparent that developing indirect potable reuse projects to use all wastewater available in the Metro System would not be practical, or provide the right balance of costs and benefits. Therefore, the water reuse target based on project constraints and permit considerations was approximately 80 to 120 mgd (upper end based on estimated regulatory flow limits to the San Vicente Reservoir in conjunction with the South Bay Spring Valley No. 8 Diversion).

8.1.5 Cost Considerations for the Water Reuse Target

As seen with the Groundwater Replenishment Project in Orange County, San Diego has the potential to save substantial costs by investing in water reuse projects instead of certain expensive upgrades of the wastewater system. The savings achieved by investing in the water reuse system in lieu of wastewater system upgrades are referred to as avoided cost savings. The biggest avoided cost identified in this Study is savings related to avoided treatment upgrade costs at the Point Loma Plant. While benefits at the Point Loma Plant are just one of many candidate cost incentives for the City's reuse program, they are the largest and most clearly connected to the recycled water program expansion.

Leading up to the Fine Screening Sessions, a reuse target of approximately 100 mgd was established in part from cost benefits derived by avoiding upgrades at the Point Loma Plant. At 100 mgd, and based on dry weather flows, certain treatment processes (primarily Biological Aerated Filters (BAF)) were avoided. This target was later checked against a wet weather scenario in the City's September 2011 Draft Wastewater Master Plan that included 2050 annual average daily flows with a 10-year return flow event. While the increased flow condition no longer allowed avoiding BAF at Point Loma, there were other benefits. The reduced flows to Point Loma resulting from the reuse program avoided the need for high rate clarifiers, reduced the amount of expensive BAF upgrades needed at the constrained Point Loma Plant site, and reduced operating costs at Pump Stations 1 and 2. For South Bay, the key analysis revolved around the timing of plant improvements and what costs should be attributable to the water



Savings at the Point Loma Plant. Avoided costs at the Point Loma Plant played an important role in establishing reuse targets. The land available at Point Loma Site is constrained, and any upgrades incur high costs.

system, the wastewater system and the existing reuse system. Multiple scenarios were evaluated to assess the costs. While the scenarios varied, the Net Cost results were within +/- \$100/acre-foot of each other and the previous results. Therefore the Study's conclusions remained consistent with the initial evaluation. A summary of the Point Loma, South Bay, and related facilities analysis is included in Appendix H.

8.2 Integrated Reuse Alternatives Summary

The Integrated Reuse Alternatives were grouped into "A" and "B" alternatives, and sub-alternatives "1," "2" and "3." Table 8-1 summarizes the elements in each alternative. The table is followed by a description of the alternatives and the numbering. Additional background on their origin is provided in Chapter 7. Each alternative included projects common to all alternatives and alternative-specific components. The four common elements included: non-potable recycled water demands served by the North City and South Bay Plants, an initial 15 mgd North City Plant indirect potable reuse project to the San Vicente Reservoir, a South Bay Plant 15 mgd indirect potable reuse project to Otay Lakes using the Spring Valley No. 8 Diversion, and a 5 mgd El Monte Groundwater Recharge Project. Conceptual flow schematics of the Alternatives are provided in Appendix K.

Table 8-1. Integrated Reuse Alternative Summary - Elements Included					
Elements in the Area Concept	A1	A2	B1	B2	B3
<i>Elements from the North City/San Vicente Area Concept Themes</i>					
Existing non-potable recycled water demands (6.7 mgd)	✓	✓	✓	✓	✓
Planned non-potable recycled water demands (2.4 mgd)	✓	✓	✓	✓	✓
North City Plant w/indirect potable reuse to San Vicente (15.0 mgd)	✓	✓	✓	✓	✓
Morena Diversion w/North City Plant expansion & indirect potable reuse to San Vicente (11.9 mgd)	✓	✓			
Harbor Drive Plant w/indirect potable reuse to San Vicente (capacity varies)	✓	✓	✓	✓	✓
Harbor Drive consolidated WRP/AWPF plant		✓		✓	✓
Harbor Drive WRP/Camino Del Rio AWPF split plant	✓		✓		
Mission Gorge Plant with indirect potable reuse to San Vicente (6.8 mgd)					✓
<i>Elements from South Bay Area Concept C2</i>					
Existing non-potable recycled water demands (4.2 mgd)	✓	✓	✓	✓	✓
Planned non-potable recycled water demands (1.8 mgd)	✓	✓	✓	✓	✓
Additional future non-potable recycled water demands (3.0 mgd)	✓	✓	✓	✓	✓
Spring Valley No. 8 Diversion to South Bay (31.1 mgd)	✓	✓	✓	✓	✓
South Bay indirect potable reuse to Otay Lakes (15.0 mgd)	✓	✓	✓	✓	✓

Note: Flows for non-potable recycled water and indirect potable reuse projects are average annual totals based on the output of the plant. Flows for the Spring Valley diversion are based on 2035 Dry Weather Flows. WRP = Water Reclamation Plant; AWPF = Advanced Water Purification Facility

The following summarizes the numbering system used for each alternative (also see Chapter 7). Each Alternative includes common South Bay components (per Table 8-1):

- **“A” Alternatives.** The “A” Alternatives expand the North City Plant to 45 mgd (the site’s master-planned capacity) using the Morena Diversion. The added capacity at North City allows the Harbor Drive Plant to be smaller than the “B” Alternatives.
- **“B” Alternatives.** The “B” Alternatives maximize the existing North City Plant capacity at 30 mgd (which occurs once the initial 15 mgd indirect potable reuse project is complete). The smaller total at the North City Plant requires the Harbor Drive Plant to be larger than the “A” Alternatives.
- **“1” Sub-alternatives.** Alternatives “A1” and “B1” differ from the “2” (A2, B2) and “3” (B3) alternatives by splitting the Harbor Drive water reclamation treatment processes and the advanced purification facility treatment into different sites (the advanced purification processes are located at the Camino Del Rio site described in Chapter 7). This adds a fourth plant site to these alternatives.
- **“2” Sub-alternative.** Alternatives “A2” and “B2” also relate to the Harbor Drive Plant. The “2” Alternatives place all the Harbor Drive water reclamation and advanced purification treatment processes at a combined plant along Harbor Drive (similar to how the proposed North City and South Bay Plants will be configured). The Harbor Drive Plant in these alternatives is larger, but the operation is efficiently consolidated to a single site.
- **“3” Sub-alternative.** Alternative “B3” is the same as Alternative “B2”, except that it includes a small plant in Mission Gorge to collect, treat, and convey water to the San Vicente Reservoir. This adds a fourth plant, but it is the closest location to the San Vicente Reservoir.

The following six pages provide an overview of the Integrated Reuse Alternatives, including the following figures and tables:

Alternative A1/A2

- Figures 8-2 and 8-3
- Tables 8-2 through 8-4

Alternative B1/B2

- Figures 8-4 and 8-5
- Tables 8-5 through 8-7

Alternative B3

- Figures 8-6 and 8-7
- Tables 8-8 through 8-10

Major Alternatives

“A” Alternatives =
North City at 45 mgd +
South Bay with SV8
diversion

“B” Alternatives =
North City at 30 mgd +
South Bay with SV8
diversion

Siting Sub-alternatives

“1” Alternatives = split
plant between Harbor
Drive & Camino del Rio

“2” Alternatives =
combined Harbor
Drive Plant

“3” Alternative =
combined Harbor Drive
plant and an additional
plant at Mission Gorge

8.2.1 Summary of Integrated Reuse Alternatives A1 and A2

Facility Map



Reuse By Phase

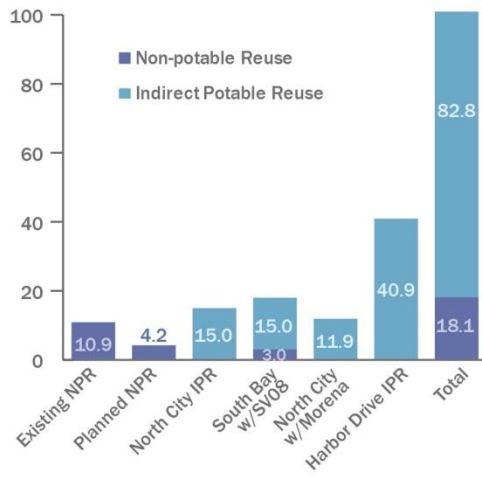

Reuse Per Plant

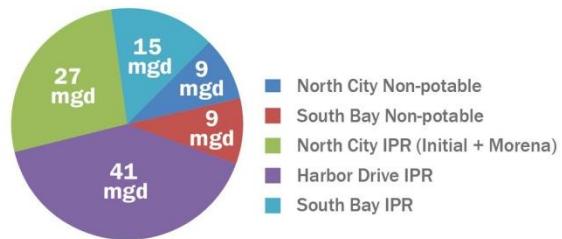

A1/A2 Allocation of Metro System Flows (2035 Dry Weather Conditions)

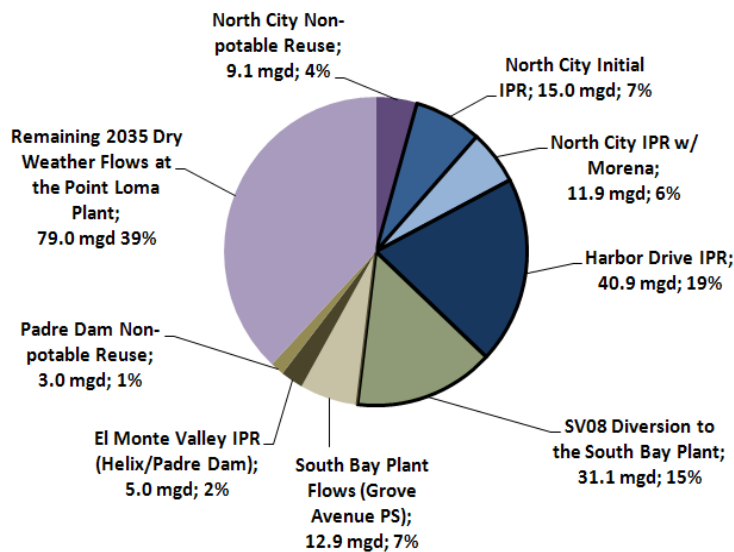

Figure 8-2 Integrated Reuse Alternatives A1 and A2

(upper left) – Displays the facilities included in Alternatives A1 and A2. A1 differs only in that the advanced treatment processes at the Harbor Drive Plant are located at the Camino del Rio site.

(Above) – The charts above include reuse totals per project and per plant for both non-potable recycled water and indirect potable reuse.

(Left) – The pie chart to the left displays the allocation of Metro System Flows estimated for the 2035 dry weather year flow scenario. The black bordered portions represent 99 mgd of offload provided by the facilities included in this Study. Wet weather allocations are presented in Appendix B.



Integrated Reuse Alternatives A1 and A2 (Continued)

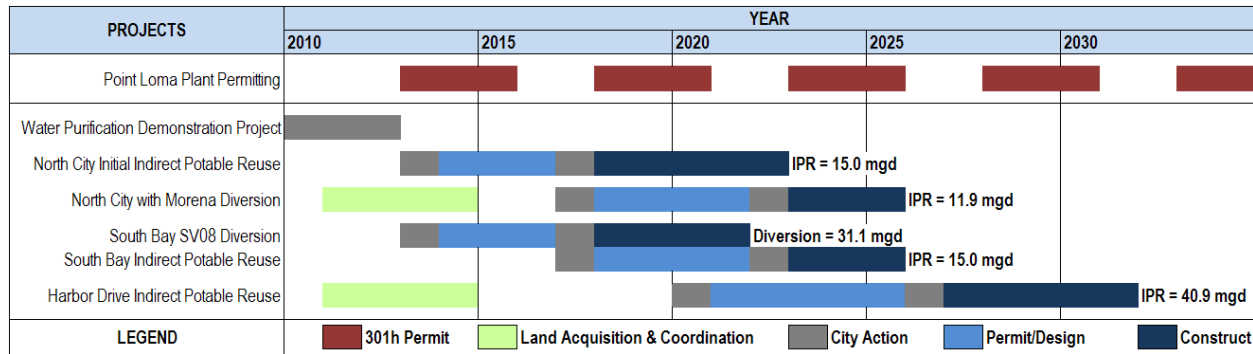

Figure 8-3. Alternative A1/A2 Implementation Schedule

Note: The planned 21 mgd expansion of South Bay as part of the September 2011 Draft Wastewater Master Plan may allow deferring or eliminating the 26 mgd primary and secondary expansion included in this Study. South Bay plant sizing and capacities shall be coordinated with wastewater planning efforts and Point Loma permit discussions per the implementation steps.

Table 8-2. Alternative A1/A2 New Water and Point Loma Offloading (Totals in mgd)								
Start of Operations	New Water (mgd)					Wastewater Offload (mgd)		
	North City	Harbor Drive	Mission Gorge	South Bay	Cumulative	Reuse (N/I South Bay)	Diverted to South Bay	Cumulative
2023	15.0	0.0	-	0.0	15.0	15.0	0.0	15.0
2022	0	0.0	-	0.0	15.0	0.0	31.1	46.1
2026	11.9	0.0	-	0.0	26.9	11.9	0.0	58.0
2026	0.0	0.0	-	18.0	44.9	0.0	0.0	58.0
2032	0.0	40.9	-	0.0	85.8	40.9	0.0	98.9

Note: New water and wastewater offloading totals are based on the reuse projects included in the cost estimates for this Study. The totals do not include the proposed El Monte Groundwater Recharge IPR Project (5 mgd); existing and planned non-potable reuse for the North City Plant (9.1 mgd) and Padre Dam Plant (3.0 mgd); and the Grove Ave. Pump Station (12.9 mgd - which accounts for South Bay non-potable reuse thru 2026). South Bay new water totals include: 15 mgd for IPR and 3 mgd for non-potable reuse (Otay Water District, 2026 to 2040). Point Loma offload totals are based on 2035 Dry Weather Flows. Point Loma offloading due to South Bay is accounted for based on the diversion flows, not the new water created.

Table 8-3. Alternative A1/A2 Capital and Annual O&M Costs							
Item		2014 North City initial	2014 South Bay Diversion	2018 Morena	2018 South Bay IPR	2021 Harbor Drive (Alternative A1)	2021 Harbor Drive (Alternative A2)
Incremental Costs	Capital	\$410,700,000	\$20,700,000	\$301,300,000	\$455,400,000	\$1,000,000,000	\$1,012,200,000
	O&M	\$17,600,000	\$300,000	\$13,100,000	\$22,700,000	\$51,000,000	\$50,800,000
Cumulative Costs	Capital	\$410,700,000	\$431,400,000	\$732,800,000	\$1,188,200,000	\$2,188,200,000	\$2,200,400,000
	O&M	\$17,600,000	\$17,900,000	\$31,000,000	\$53,600,000	\$104,700,000	\$104,500,000

Note: Capital & O&M Costs shown above are from the Favorable financial model scenario, and include a 20-percent project contingency.

Table 8-4. Alternative A1/A2 Reuse Water Cost Summary (2011 \$/AF)		
Cost Category	Alternative A1	Alternative A2
Gross Costs (Before Avoided Facilities and Other Offset Savings)	\$1,900	\$1,900
Tier 1 Net Costs (With Direct Wastewater System Savings)	\$1,300	\$1,300
Tier 2 Net Costs (With Salt Credit Plus Tier 1 Savings)	\$1,200	\$1,200
Tier 3 Net Costs (With Indirect Wastewater System Savings Plus Tier 1 and Tier 2 Savings)	\$800	\$800
2011 Untreated Imported Water Costs (for comparison purposes)	\$904	\$904

Note: The reuse water cost summary above represents average costs based on the Favorable and Unfavorable financial model scenarios. See Section 8.4 for more details on the financial evaluation and cost descriptions. Tier 1 savings includes wastewater projects no longer necessary due to the reuse projects and offloading included in this Study. Tier 2 savings accounts for savings due to water quality improvements. Tier 3 conceptualizes the savings that could occur if maintaining chemically enhanced primary treatment at the Point Loma Plant was made possible due to the reuse program proposed in this Study. Costs shown above are for comparison of untreated water options, and do not include potable water treatment plant costs.



8.2.2 Summary of Integrated Reuse Alternatives B1 and B2

Facility Map



Reuse By Phase

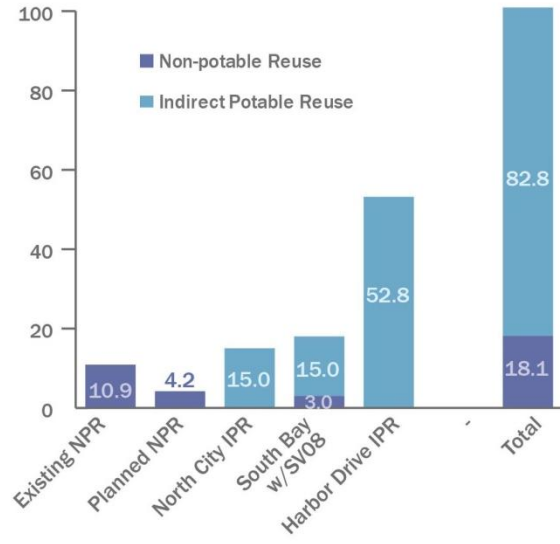

Reuse Per Plant

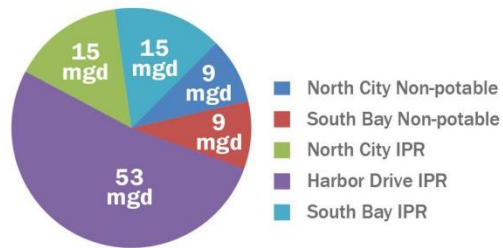

B1/B2 Allocation of Metro System Flow (2035 Dry Weather Conditions)

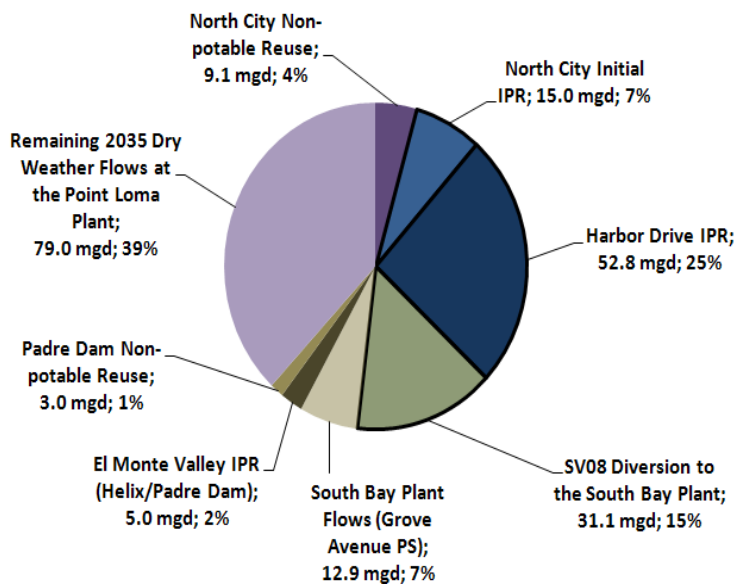

Figure 8-4. Integrated Reuse Alternatives B1 and B2

(upper left) – Displays the facilities included in Alternatives B1 and B2. B1 differs only in that the advanced treatment processes at the Harbor Drive Plant are located at the Camino del Rio site.

(Above) – The charts above include reuse totals per project and per plant for both non-potable recycled water and indirect potable reuse.

(Left) – The pie chart to the left displays the allocation of Metro System Flows estimated for the 2035 dry weather year flow scenario. The black bordered portions represent 99 mgd of offload provided by the facilities included in this Study. Wet weather allocations are presented in Appendix B.



Summary of Integrated Reuse Alternatives B1 and B2 (Continued)

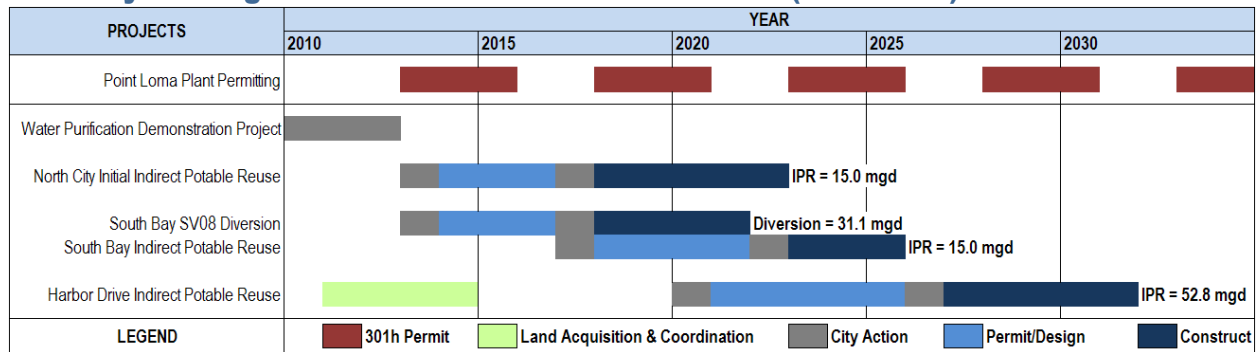

Figure 8-5. Alternative B1/B2 Implementation Schedule

Note: The planned 21 mgd expansion of South Bay as part of the September 2011 Draft Wastewater Master Plan may allow deferring or eliminating the 26 mgd primary and secondary expansion included in this Study. South Bay plant sizing and capacities shall be coordinated with wastewater planning efforts and Point Loma permit discussions per the implementation steps.

Table 8-5. Alternative B1/B2 New Water and Point Loma Offloading (Totals in mgd)

Start of Operations	New Water (mgd)					Wastewater Offload (mgd)		
	North City	Harbor Drive	Mission Gorge	South Bay	Cumulative	Reuse (N/I South Bay)	Diverted to South Bay	Cumulative
2023	15.0	0.0	-	0.0	15.0	15.0	0.0	15.0
2022	0.0	0.0	-	0.0	15.0	0.0	31.1	46.1
2026	0.0	0.0	-	18.0	33.0	0.0	0.0	46.1
2032	0.0	52.8	-	0.0	85.8	52.8	0.0	98.9

Notes: New water and wastewater offloading totals are based on the reuse projects included in the cost estimates for this Study. The totals do not include the proposed El Monte Groundwater Recharge IPR Project (5 mgd); existing and planned non-potable reuse for the North City Plant (9.1 mgd) and Padre Dam Plant (3.0 mgd); and the Grove Ave. Pump Station (12.9 mgd - which accounts for South Bay non-potable reuse thru 2026). South Bay new water totals include: 15 mgd for IPR and 3 mgd for non-potable reuse (Otay Water District, 2026 to 2040). Point Loma offload totals are based on 2035 Dry Weather Flows. Point Loma offloading due to South Bay is accounted for based on the diversion flows, not the new water created.

Table 8-6. Alternative B1/B2 Capital and Annual O&M Costs

Item		2014	2014	2018	2021	2021
		North City initial	South Bay Diversion	South Bay IPR & 3 mgd non-potable	Harbor Drive (Alternative B1)	Harbor Drive (Alternative B2)
Incremental Costs	Capital	\$340,700,000	\$20,700,000	\$455,400,000	\$1,159,900,000	\$1,168,300,000
	O&M	\$17,300,000	\$300,000	\$22,700,000	\$61,200,000	\$60,500,000
Cumulative Costs	Capital	\$340,700,000	\$361,400,000	\$816,800,000	\$1,976,700,000	\$1,985,100,000
	O&M	\$17,300,000	\$17,600,000	\$40,300,000	\$101,500,000	\$100,800,000

Note: Capital & O&M Costs shown above are from the Favorable financial model scenario, and include a 20-percent project contingency.

Table 8-7. Alternative B1/B2 Unit Cost Summary (2011 \$/AF)

Cost Category	Alternative B1	Alternative B2
Gross Costs (Before Avoided Facilities and Other Offset Savings)	\$1,700	\$1,700
Tier 1 Net Costs (With Direct Wastewater System Savings)	\$1,100	\$1,100
Tier 2 Net Costs (With Salt Credit Plus Tier 1 Savings)	\$1,000	\$1,000
Tier 3 Net Costs (With Indirect Wastewater System Savings Plus Tier 1 and Tier 2 Savings)	\$600	\$600
2011 Untreated Imported Water Costs (for comparison purposes)	\$904	\$904

Note: The reuse water cost summary above represents average costs based on the Favorable and Unfavorable financial model scenarios. See Section 8.4 for more details on the financial evaluation and cost descriptions. Tier 1 savings includes wastewater projects no longer necessary due to the reuse projects and offloading included in this Study. Tier 2 savings accounts for savings due to water quality improvements. Tier 3 conceptualizes the savings that could occur if maintaining chemically enhanced primary treatment at the Point Loma Plant was made possible due to the reuse program proposed in this Study. Costs shown above are for comparison of untreated water options, and do not include potable water treatment plant costs.



8.2.3 Summary of Integrated Reuse Alternative B3

Facility Map



Reuse by Phase

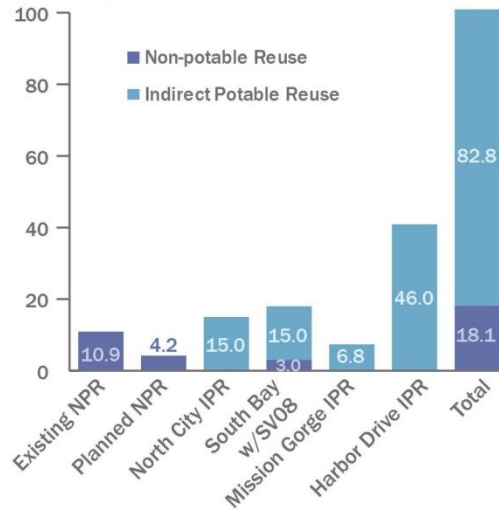

Reuse Per Plant

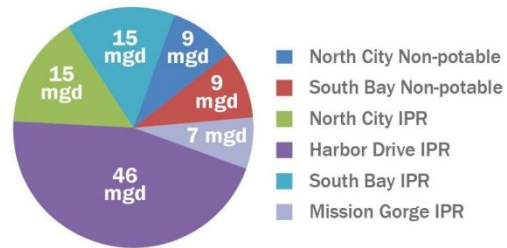

B3 Allocation of Metro System Flows (2035 Dry Weather Conditions)

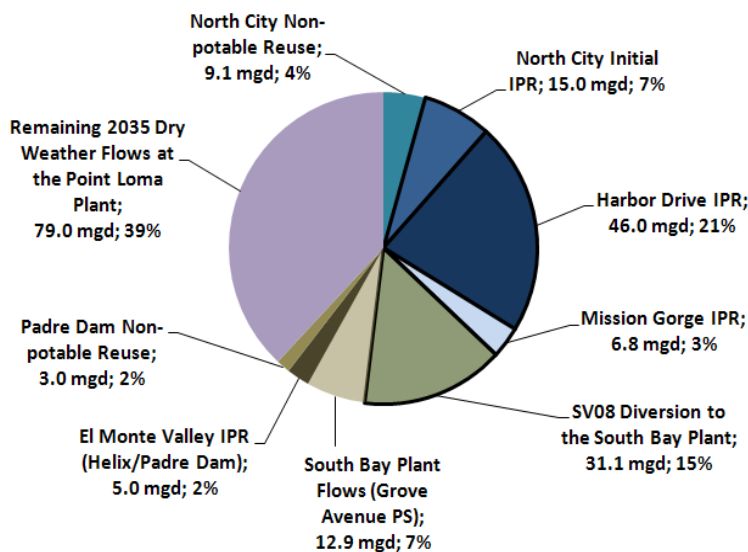

Figure 8-6. Integrated Reuse Alternative B3

(upper left) – Displays the facilities included in Alternative B3. The Mission Gorge Plant is the only difference between this Alternative and Alternative B2.

(Above) – The charts above include reuse totals per project and per plant for both non-potable recycled water and indirect potable reuse.

(Left) – The pie chart to the left displays the allocation of Metro System Flows estimated for the 2035 dry weather year flow scenario. The black bordered portions represent 99 mgd of offload provided by the facilities included in this Study. Wet weather allocations are presented in Appendix B.

Summary of Integrated Reuse Alternative B3 (Continued)

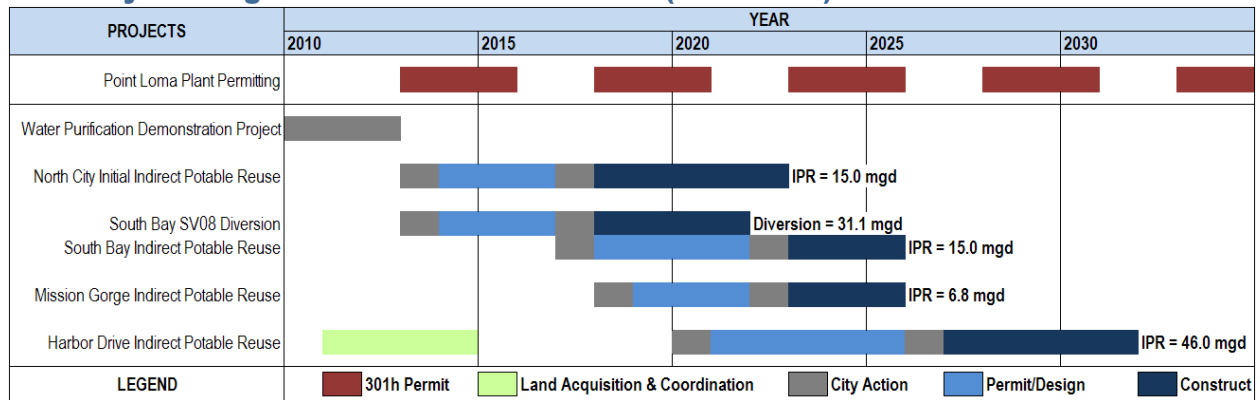

Figure 8-7. Alternative B3 Implementation Schedule

Note: The planned 21 mgd expansion of South Bay as part of the September 2011 Draft Wastewater Master Plan may allow deferring or eliminating the 26 mgd primary and secondary expansion included in this Study. South Bay plant sizing and capacities shall be coordinated with wastewater planning efforts and Point Loma permit discussions per the implementation steps.

Table 8-8. Alternative B3 New Water and Point Loma Offloading (Totals in mgd)

Start of Operations	New Water (mgd)					Wastewater Offload (mgd)		
	North City	Harbor Drive	Mission Gorge	South Bay	Cumulative	Reuse (N/I South Bay)	Diverted to South Bay	Cumulative
2023	15.0	0.0	0.0	0.0	15.0	15.0	0.0	15.0
2022	0.0	0.0	0.0	0.0	15.0	0.0	31.1	46.1
2026	0.0	0.0	0.0	18.0	33.0	0.0	0.0	46.1
2026	0.0	0.0	6.8	0.0	39.8	6.8	0.0	52.9
2032	0.0	46.0	0.0	0.0	85.8	46.0	0.0	98.9

Note: New water and wastewater offloading totals are based on the reuse projects included in the cost estimates for this Study. The totals do not include the proposed El Monte Groundwater Recharge IPR Project (5 mgd); existing and planned non-potable reuse for the North City Plant (9.1 mgd) and Padre Dam Plant (3.0 mgd); and the Grove Ave. Pump Station (12.9 mgd - which accounts for South Bay non-potable reuse thru 2026). South Bay new water totals include: 15 mgd for IPR and 3 mgd for non-potable reuse (Otay Water District, 2026 to 2040). Point Loma offload totals are based on 2035 Dry Weather Flows. Point Loma offloading due to South Bay is accounted for based on the diversion flows, not the new water created.

Table 8-9. Alternative B3 Capital and Annual O&M Costs

Item		2014 North City initial	2014 South Bay Diversion	2018 South Bay IPR & 3 mgd non-potable	2019 Mission Gorge	2021 Harbor Drive
Incremental Costs	Capital	\$332,600,000	\$20,700,000	\$455,400,000	\$279,000,000	\$1,073,200,000
	O&M	\$17,300,000	\$300,000	\$22,700,000	\$13,500,000	\$55,000,000
Cumulative Costs	Cumulative Capital Cost	\$332,600,000	\$353,400,000	\$808,800,000	\$1,087,800,000	\$2,160,900,000
	Cumulative O&M Cost	\$17,300,000	\$17,600,000	\$40,300,000	\$53,700,000	\$108,700,000

Note: Capital & O&M Costs shown above are from the Favorable financial model scenario, and include a 20-percent project contingency.

Table 8-10. Alternative B3 Unit Cost Summary (2011 \$/AF)

Cost Category	Alternative B3
Gross Costs (Before Avoided Facilities and Other Offset Savings)	\$1,900
Tier 1 Net Costs (With Direct Wastewater System Savings)	\$1,300
Tier 2 Net Costs (With Salt Credit Plus Tier 1 Savings)	\$1,200
Tier 3 Net Costs (With Indirect Wastewater System Savings Plus Tier 1 and Tier 2 Savings)	\$800
2011 Untreated Imported Water Costs (for comparison purposes)	\$904

Note: The reuse water cost summary above represents average costs based on the Favorable and Unfavorable financial model scenarios. See Section 8.4 for more details on the financial evaluation and cost descriptions. Tier 1 savings includes wastewater projects no longer necessary due to the reuse projects and offloading included in this Study. Tier 2 savings accounts for savings due to water quality improvements. Tier 3 conceptualizes the savings that could occur if maintaining chemically enhanced primary treatment at the Point Loma Plant was made possible due to the reuse program proposed in this Study. Costs shown above are for comparison of untreated water options, and do not include potable water treatment plant costs.



8.3 Evaluation Summary for the Integrated Reuse Alternatives

The Integrated Reuse Alternatives were evaluated during the Fine Screening Session and subsequent Stakeholder Status Update Meetings. Each Integrated Reuse Alternative provides common and distinct benefits, as summarized in Table 8-11.

Table 8-11. Integrated Reuse Alternative Comparative Summary

Alternative	Institutional Complexity	Technical Complexity	Treatment Plant Sites	Wastewater Diversions	Key Infrastructure Siting and Complexity Considerations
A1	Med	High (Morena Diversion/Split Split Plant Harbor Drive-Camino del Rio)	4	2	<ul style="list-style-type: none"> • Smallest area requirement at the Harbor Drive site • Challenging siting at Camino del Rio site • Challenging siting and operation of the Morena Wastewater Diversion Pump Station • Most pumping of all alternatives due to Morena Diversion • Increased costs due to added brine line
A2	Med	Med/High (Morena Diversion)	3	2	<ul style="list-style-type: none"> • Reduced Harbor Drive Plant siting needs compared to the “B” alternatives • Challenging siting and operation of the Morena Wastewater Diversion Pump Station
B1	Med	Med/High (split Plant Harbor Drive-Camino del Rio)	4	1	<ul style="list-style-type: none"> • Reduced Harbor Drive Plant siting needs compared to B2 • Minimal wastewater pumping • Challenging siting at the Camino del Rio site • Reduced ability to phase • Increased costs due to added brine line
B2	Med	Med	3	1	<ul style="list-style-type: none"> • Largest area requirement at the Harbor Drive site • Least cost option • Minimal wastewater and tertiary water pumping • Reduced ability to phase
B3	High (Harbor Drive site & Mission Gorge site)	High (4th Water Reclamation Plant/ Advance Water Purification Facility at Mission Gorge)	4	1	<ul style="list-style-type: none"> • Multiple agency collaboration could drive further economy of scale benefits • Allows for additional phasing opportunities • Closest plant to San Vicente Reservoir reduces overall pumping • Mission Gorge site requires interagency agreements and administration costs • Mission Gorge Plant is relatively small due to smaller tributary wastewater flows limited and reduces Harbor Drive Plant economy of scale • Larger upstream treatment at Mission Gorge Plant impacts downstream water quality at Harbor Drive Plant • Reduced flows/concentrated waste downstream of Mission Gorge Plant may create maintenance issues • Easterly plant may be less advantageous if direct potable reuse becomes a reality in the future as a majority of the demands are to the west and this would reduce piping and pumping costs from the Harbor Drive Plant furthering benefitting its economy of scale in relation to smaller more remote plants

Notes:

- Alternative A1 and B1 include a split Harbor Drive Plant at the Harbor Drive site and Camino Del Rio site. Although these facilities work together, they were considered separate treatment plant sites in the table above.
- Wastewater Diversions can include the Morena diversion to the North City Plant and the Spring Valley No. 8 Diversion to the South Bay Plant. These diversions require wastewater pump stations.
- South Bay facilities not included above since common to all Alternatives.



8.4 Financial Evaluation of Alternatives

A financial evaluation was performed, which included each Integrated Reuse Alternative considered in this Study. The financial evaluation was prepared to ultimately help decision-makers compare the costs of different water reuse approaches and to aid in making decisions about whether to invest in the water reuse system. The guiding principles for the evaluation included:

- Provide transparent costing of alternatives.
- Provide multiple opportunities at workshops and Stakeholder meetings to review, discuss, and debate project costs.
- Prepare a comparative financial evaluation of the Integrated Reuse Alternatives and include financing costs.
- Compare the water reuse alternative costs to other options facing the City and Participating Agencies.

The financial evaluation included a Net Present Value financial spreadsheet model (financial model). The financial model was used to calculate and compare unit costs (in terms of dollars per acre foot) for each Integrated Reuse Alternative against the current cost of imported untreated water. The financial model included fixed and variable inputs, which were used to perform a sensitivity analysis.

8.4.1 Financial Model Cost Components

The costing process consisted of a multi-step approach. The following summarizes the major steps:

- **Development of Unit Costs for Infrastructure.** Unit costs for treatment and conveyance facilities were prepared to estimate infrastructure costs. The unit costs were based on 23 Bid Summaries, two formal agency estimating tools, 14 project cost estimates, and insight and experience from the three national consulting team members performing this Study. The unit costs were first reviewed in the Coarse Screening Session and updated through the course of the project. One revision included modifying the unit costs to provide economy of scale adjustments (i.e. larger facilities are less expensive to build and operate than smaller facilities with similar processes and construction methods). This adjustment was based on City cost data and the EPA's *Guide to the Selection of Cost-Effective Wastewater Treatment Systems* (EPA-430/9-75-002; July 1975).
- **Integrated Reuse Alternative Costs.** Costs for each alternative were developed and reviewed in the Coarse Screening Session and the Fine Screening Session. The costs included:
 - **Capital Costs.** Capital costs were developed using the Study's unit costs described above. Capital costs were multiplied by cost factors related to the difficulty of construction at each site. Factors varied from 1.0 to 1.5 times the unit costs. Tunneling allowances were also included as an allowance for utility conflicts and for avoiding high traffic areas, streams, freeways, rail, or sensitive environmental areas.
 - **Operation and Maintenance Costs.** Operation and maintenance costs were also developed based on the Study's unit costs (for treatment facilities) and values developed in the 2005 Water Reuse Study (for conveyance facilities including pipelines, pump stations and reservoirs). Treatment facility costs included labor, chemicals, energy, and materials. Costs for conveyance facilities were calculated as a percentage of the capital costs. An electricity cost of \$0.12 per kilowatt-hour was used for treatment and pump station operations.
 - **Soft Costs.** A 50-percent soft cost allowance was provided for Engineering, Administration, Legal, Construction Management and Environmental Permitting costs

- **Land Acquisition.** Although a majority of the facilities planned are located on City parcels, additional land or alignments may need to be acquired. A cost equal to 4 percent of the estimated construction cost was included for these purposes.
- **Financial Model Assumptions.** Financial model assumptions were coordinated for consistency with other City financial model assumptions. These assumptions were fixed for all scenarios. It is the practice of the City to finance 20-percent of all capital projects with rates and fees. Funds derived from rates are the main source of funds for day-to-day operational and maintenance costs and debt coverage requirements. The assumptions related to financing include the following:
 - Interest rate of 5.5 percent on revenue bonds and 2.5 percent on State Revolving Fund (SRF) loans
 - Repayment period of 30 years on revenue bonds and 20 years on SRF loans
 - Issuance costs of 2.5 percent on revenue bonds and 1.0 percent on SRF loans
 - Debt coverage of 1.25 percent on revenue bonds and 1.2 percent on SRF loans
 - Maximum loan under SRF of \$50 million per year
 - Complying with revenue bonds requires a reserve amount equal to one payment to be set aside at issuance
 - O&M escalation for chemical, energy, and labor set at 4.0 percent; Capital cost escalation set at 3.0 percent
 - Net Present Value analysis for 50 years
 - ENR Los Angeles cost basis index of 10051.30

8.4.2 Comparative Costs Basis Using a Sensitivity Analysis

The costs for the reuse program proposed in this Study will be compared to the cost of imported untreated water, and other alternative water supply projects (such as desalination). It is important to note that the cost presented for the reuse alternatives in this Study are fully loaded (including capital, O&M and financing costs). It is common for other new alternative water supply costs to be partial costs, including overly optimistic assumptions or certain exclusions. The costs for the alternatives presented in this Report were prepared to provide thorough and realistic budgetary estimates

8.4.3 Gross Costs

Gross Costs were calculated to determine the investment required for each Integrated Reuse Alternative. To achieve a realistic picture of Gross Costs, the financial evaluation included a sensitivity analysis with bracketed (bookend) conditions, using variables described as follows and summarized in Table 8-12:

- **Favorable Condition.** The favorable condition assumed the best-case scenario using the most favorable cost variables. This included 30-percent grant funding, \$450 per acre-foot local resource program credits for 20 years, and a 20-percent project contingency.
- **Unfavorable Condition.** The unfavorable condition assumed the worst-case scenario related to the variable costs. This condition included 10-percent grant funding, \$100 per acre-foot local resource program credits for 20 years, and a 40-percent project contingency.

Table 8-12. Gross Costs Variables

Item	Description	Favorable Scenario	Unfavorable Scenario	Average
Grants	To help offset the costs associated with projects, the City can apply for grants to help finance a portion of the capital projects. Grants usually consist of funds that are obtained from state or federal agencies and do not need to be paid back. This is the preferred option among municipal utilities. The grants usually have stipulations regarding the type of projects that can be included and how the money is managed; therefore, additional administrative costs also come with the funds. Typically, grant amounts vary depending on the project type. Projects promoting water reuse have generally been well supported, with multiple programs such as the Bureau of Reclamation's Title XVI Program and California's bond measures. The analysis assumes receiving grant funding offsetting 10 to 30-percent of each Integrated Reuse Alternative's capital costs.	30%	10%	20%
Local Resource Program	To help offset the costs associated with new water projects, the City has participated in the Local Resource Program offered by MWD and the Local Water Supply Development funding provided by the SDCWA (these two programs are collectively referred to herein as the LRP). The LRP was created to promote the development of water recycling and groundwater recovery projects in order to replace an existing demand or prevent a new demand on imported water supplies. Since the City relies indirectly on imported water from MWD/SDCWA, it may be eligible to receive a credit up to \$450 per acre-foot produced. The program is dependent on available funding and agency approvals and usually comes with a fixed term. For this Study, a 20-year term and a funding level of \$100 to \$450 per acre-foot were assumed. One caveat is that the LRP credit is discontinued once the cost to produce the alternative water supply source becomes cheaper than the cost of imported water.	\$450/acre-foot, 20 years	\$100/acre-foot, 20 years	\$275/acre-foot, 20 years
Project Contingency	A project contingency was added to the construction costs of all alternatives. Contingencies are important at this level of planning to account for unknown conditions or additional facilities needed once more detailed evaluations or design is complete. The analysis assumes project contingencies adding 20-percent to 40-percent to the Integrated Reuse Alternative's capital costs.	20%	40%	30%

8.4.4 Net Costs

Net Costs are considered “real” or “true” costs for the purposes of comparing reuse projects to imported untreated water and other alternative water sources. Net Costs account for savings, offsets and credits that occur as a result of the reuse projects. For example, constructing a new reuse plant upstream of the Point Loma Plant reduces flows to the Point Loma Plant, resulting in lower capital and operational costs at the Point Loma Plant. These reduced costs are subtracted from the Gross Costs to get the Net Costs or “true” program cost. This is similar to the Orange County Groundwater Replenishment System, which was responsible for substantial savings by avoiding costly outfall improvements.

The variables associated with the Net Cost calculations are described in Table 8-13. Additional information regarding Net Costs is included in a Cost Methodology Summary included in Appendix H. The Cost Methodology Summary is presented in an informative, frequently asked question (FAQ) format. This document summarizes direct and indirect wastewater savings calculations and includes a graphical comparison of the key wastewater facilities included in this Study with the City's September 2011 Draft Wastewater Master Plan facilities.

Table 8-13. Net Cost Variables

Component	Description	Savings
Tier 1 - Direct Wastewater System Savings <ul style="list-style-type: none"> • Reduction of flows to downstream facilities • Remaining Point Loma capacity is upgraded to Secondary 	<p>The Study's Alternatives achieve the goal of offloading flows away from the Point Loma Plant, resulting in reduced capital and operating costs at downstream wastewater facilities. The direct wastewater system savings were calculated by comparing the size of the Point Loma Plant proposed in the City's September 2011 Draft Wastewater Master Plan (adjusted to a secondary treatment option) to the smaller Point Loma Plant size (which includes secondary treatment) in this Study (assuming the reuse projects in this Recycled Water Study are implemented). The cost difference is the savings directly attributable to these reuse projects. See Appendix H for additional details.</p>	<p>\$557 million (capital savings)</p> <p>\$27.6 million/year (operation and maintenance savings)</p>
Tier 2 - Salt Reduction Credit <ul style="list-style-type: none"> • Water quality improvements to water & wastewater systems due to indirect potable reuse • Homeowner and business benefits not included in total 	<p>Similar to the 2005 Water Reuse Study, a salt credit was considered to account for the benefits of salinity reduction in the watershed. The salt credit basis is from the 1999 Salinity Management Study (MWD, USBR). The quantitative credit shown is the financial benefits of extending the life of the municipal water and wastewater treatment systems from having lower salinity levels in the water and wastewater flows. The San Vicente and Otay Lakes Reservoirs could see dramatic reductions in salinity levels from the proposed indirect potable reuse projects. Downstream agency facilities including drinking water treatment plants and the Harbor Drive advanced water purification facilities would benefit from this reduced salinity. In addition to the benefit shown, there is a benefit to water customers, since water heaters, clothes washers, dishwashers, and fixtures will also last longer with lower salinity levels. The combined savings included in the City's 2005 Water Reuse Study was \$250/AF. The \$100/AF value used in this Study only accounts for the estimated municipal treatment equipment savings.</p>	<p>\$100/acre foot (not including customer savings)</p>
Tier 3 - Indirect Wastewater System Savings <ul style="list-style-type: none"> • Remaining Point Loma capacity maintained at CEPT • Quantifies savings if this approach is attributable to the reuse program 	<p>The Point Loma Plant will either continue to use chemically enhanced primary treatment or will require upgrades to secondary treatment. This Study does not provide an opinion on whether CEPT or secondary treatment processes should be employed at the Point Loma Plant. However, it is prudent to summarize the reduced Point Loma capital and operational costs if CEPT status could be maintained for the remaining Point Loma Plant capacity after reuse projects and with the South Bay Diversion. The indirect wastewater savings are therefore calculated as the avoided secondary treatment costs at the Point Loma Plant. See Appendix H for additional details.</p>	<p>\$463 million (capital savings)</p> <p>\$13.0 million/year (operation and maintenance savings).</p>
Qualitative Water System Savings	<p>The local, regional and statewide water systems were considered for potential savings from increasing water reuse. Since quantitative costs could not be developed with current available information, qualitative benefits were considered, particularly at the regional and statewide level. The region's local water treatment plants treat water from local runoff (which is limited) and imported untreated water from the SDCWA and MWD (which is subject to cutbacks and higher price fluctuations). Indirect potable reuse projects provide a reliable, uninterrupted untreated water equivalent that would help supply the local water treatment plants that ratepayers have invested in over the past decade. Indirect potable reuse projects may defer or eliminate the need to expand the imported untreated water conveyance system needed to serve these treatment plants. The SDCWA Master Plan (currently underway) may help quantify what these benefits are in future updates to this Study. In addition, Stakeholders emphasized an additional benefit related to the need to fix water supply conditions in the California Bay-Delta (which has the potential for substantial cost impacts for Southern California). Water reuse projects reduce the burden on importing water from the Bay-Delta, providing an additional benefit for these projects.</p>	<p>Quantitative benefits are speculative, therefore this category is currently considered qualitatively</p>

8.4.5 Cost Summary for Integrated Reuse Alternatives

The Integrated Reuse Alternative costs are summarized in Table 8-14. The table includes a tiered breakout of summary level costs based on the Gross Costs and Net Costs categories described above. As shown, the costs for A1, A2 and B3 are nearly identical to each other, and slightly higher than B1 and B2. For the A1/A2



comparison to B1/B2, the increased costs occur mainly due to the additional wastewater facilities and pumping needed to divert flows from Morena to the North City Plant. For the B3 comparison to B1/B2, B3 adds an additional plant and does not have the same economy of scale that the B1 and B2 Alternatives have. Implementation steps are included later in this Chapter, which include steps to further develop the Alternatives and look for additional cost savings.

Table 8-14. Cost Summary (2011 \$/AF)

Alternative	Average Gross Costs	Net Costs		
		Tier 1 - Direct Wastewater System Savings	Tier 2 - Salt Reduction Credit	Tier 3 - Indirect Wastewater System Savings
		<i>Remaining Point Loma capacity upgraded to Secondary</i>	<i>Water Quality Benefit to Water/Wastewater System</i>	<i>Remaining Point Loma capacity maintained at CEPT</i>
A1: North City 45 mgd; Split Harbor Dr. AWWPF	\$1,900	\$1,300	\$1,200	\$800
A2: North City 45 mgd; Consolidated Harbor Dr. AWWPF	\$1,900	\$1,300	\$1,200	\$800
B1: North City 30 mgd; Split Harbor Dr. AWWPF	\$1,700	\$1,100	\$1,000	\$600
B2: North City 30 mgd; Consolidated Harbor Dr. AWWPF	\$1,700	\$1,100	\$1,000	\$600
B3: North City 30 mgd; Consolidated Harbor Dr. AWWPF; Mission Gorge AWWPF	\$1,900	\$1,300	\$1,200	\$800

Notes:

- All Alternatives include South Bay Option C2 expansion with the Spring Valley No. 8 Diversion
- Direct and indirect wastewater system savings based on a comparison between the City's September 2011 Draft Wastewater Master Plan and the reduced wastewater facility sizing and pumping required as a result of the projects included in this Recycled Water Study (see Appendix H).
- Totals are in 2011 dollars (ENR Los Angeles Index value of 10,051.30, June 2011) and are based on a net present value analysis using a detailed financial model.
- Financial model sensitivity analysis generally produced cost ranging +/- \$200/AF of the values shown. Favorable conditions could result in lower costs than shown.

Key Study Conclusion

The Alternative Net Costs represent the costs that should be compared to other water sources – particularly imported untreated water. The average costs of the Alternatives above are:

- Cost assuming direct wastewater savings = \$1,200/AF
- Cost assuming above plus salt credit = \$1,100/AF
- Cost assuming above plus indirect wastewater savings = \$700/AF

These costs compare well to the 2011 untreated water cost of \$904 per acre foot, and are more economical than most other new water supply concepts being proposed.



The net cost tiers are summarized as follows:

- **Tier 1: Net Costs with Direct Wastewater System Savings.** This tier includes the Direct Wastewater System Savings that occur as a result of the water reuse projects in this Study which help to avoid approximately 100 mgd of secondary treatment improvements at the Point Loma Plant. This tier represents the first threshold in which the Alternative costs should be considered for comparison to the cost of other water sources – such as imported untreated water or other new water sources. The comparison, as outlined in the next section, is very favorable compared to untreated water and more economical than most water supply concepts being proposed at this time.
- **Tier 2: Net Costs with the Salt Credit (Including Tier 1 Savings).** This tier includes the Salt Reduction Credit Savings and adds a \$100/acre-foot credit occurring as a result of the water quality benefits created by implementing indirect potable reuse projects. The savings included is attributable to benefits received by agency facilities downstream of the new projects, including wastewater facilities. Additional savings (not accounted for in this total) would be experienced by homeowners and business as described in Chapter 6. Although these benefits are real, the ability to recover these savings and allocate them to the reuse program led to extracting this element as a separate unit cost tier so it may be considered separately from other savings.
- **Tier 3: Net Costs with Indirect Wastewater System Savings (including Tier 1 and Tier 2 Savings).** As described in the table above, this Study does not provide an opinion on whether the Point Loma Plant should continue to use CEPT treatment processes or upgrade to secondary processes. However, it was considered appropriate to list the Net Costs of the new water if the water reuse program proposed in this Study led to maintaining CEPT treatment for the remaining flows that reach the Point Loma Plant (i.e., the remaining flows that are not recycled upstream).

The Study Alternative’s Net Costs were extrapolated based on a 3.5-percent inflation rate and compared to projected untreated imported water rate as shown in Figure 8-8. The 2011 SDCWA municipal and industrial untreated imported water rate was \$904 per acre foot. The existing rate was inflated through 2020 based on the “low-rate” scenario values provided by the SDCWA in April 2011 (which averages to a 5.8-percent annual increase). Beyond 2020, the untreated water cost projections were bracketed based on various infiltration scenarios ranging from 3 to 6 percent (shown as the shaded area). These scenarios compare well to the Net Costs of the Study’s Alternatives (shown as solid lines). The Study’s Net Costs shown are the average of all the Study Alternatives and an average of the Favorable and Unfavorable scenario (i.e., the lower cost B1/B2 Alternatives and the favorable scenario would lower the reuse costs further). As shown, the average Tier 1 and Tier 2 cost curves have Net Costs lower than most of the untreated imported water rate scenarios. If the Tier 3 savings are attributed to the projects in this Study, the program would have significantly lower Net Costs than all untreated imported water rate scenarios. An additional consideration is the long-term effects that other local water projects and reduced demands are causing to MWD/SDCWA rates. As purchases decline, rates must increase to cover fixed costs. This is likely to cause imported water costs to inflate faster than locally controlled projects. Overall, the conclusion of this analysis supports the water reuse program proposed in this Study.

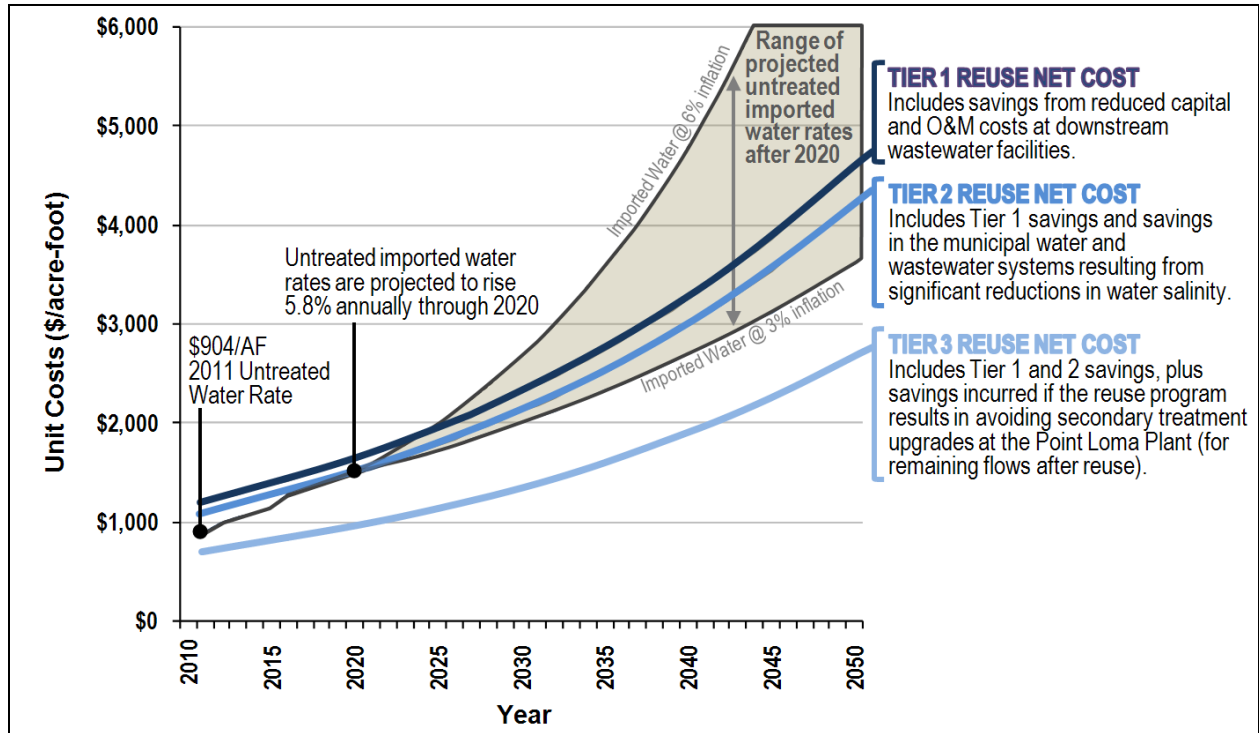

Figure 8-8. Comparison of Reuse Alternative Net Costs to Imported Untreated Water

The Integrated Reuse Alternative Net Costs compare well to projected untreated imported water rates. Untreated water rates are projected to rise 5.8 percent through 2020 and there remain many uncertainties regarding future costs associated with the Bay-Delta fix and imported water.

A detailed cost breakdown for the Favorable and Unfavorable Financial Evaluation scenarios is included in Tables 8-15 and 8-16, respectively. Capital and operation and maintenance cost estimates for each Integrated Reuse Alternative can be found in Appendix F.

Table 8-15. Financial Details for the Favorable Scenario

Item	Theme A1	Theme A2	Theme B1	Theme B2	Theme B3
O&M and Capital Debt					
Interest from Reserve	25,769,150	25,923,958	23,557,882	23,663,931	25,715,525
Operation & Maintenance	1,757,803,600	1,753,642,189	1,612,278,853	1,599,768,756	1,799,893,592
Debt Service	<u>876,467,167</u>	<u>881,123,259</u>	<u>776,617,870</u>	<u>779,795,118</u>	<u>854,165,858</u>
Total PV Cost	\$2,608,501,617	\$2,608,841,490	\$2,365,338,840	\$2,355,899,943	\$2,628,343,925
Total Cost, Annual Payments	\$154,061,888	\$154,081,962	\$139,700,342	\$139,142,867	\$155,233,804
Capital (PAYGO Financed)					
PAYGO Financing	<u>321,118,587</u>	<u>322,724,896</u>	<u>283,626,663</u>	<u>284,730,678</u>	<u>311,771,510</u>
Total PV Cost	\$321,118,587	\$322,724,896	\$283,626,663	\$284,730,678	\$311,771,510
Total Cost, Annual Payments	\$18,965,729	\$19,060,600	\$16,751,402	\$16,816,607	\$18,413,677
Credits/Avoided Costs					
LRP Credit	<u>200,257,301</u>	<u>200,257,301</u>	<u>191,430,259</u>	<u>191,430,259</u>	<u>196,474,283</u>
Total PV Cost	\$200,257,301	\$200,257,301	\$191,430,259	\$191,430,259	\$196,474,283
Total Cost, Annual Payments	\$11,827,487	\$11,827,487	\$11,306,149	\$11,306,149	\$11,604,056
Tier 1: Wastewater O&M Avoided Costs	515,354,315	515,354,315	515,354,315	515,354,315	515,354,315
Wastewater PAYGO/Debt Avoided Costs	<u>436,611,784</u>	<u>436,611,784</u>	<u>436,611,784</u>	<u>436,611,784</u>	<u>436,611,784</u>
Total PV Cost	\$951,966,099	\$951,966,099	\$951,966,099	\$951,966,099	\$951,966,099
Total Cost, Annual Payments	\$56,224,498	\$56,224,498	\$56,224,498	\$56,224,498	\$56,224,498
Tier 2: Salt Credit	<u>184,706,087</u>	<u>184,706,087</u>	<u>178,800,483</u>	<u>178,800,483</u>	<u>182,175,128</u>
Total PV Cost	\$184,706,087	\$184,706,087	\$178,800,483	\$178,800,483	\$182,175,128
Total Cost, Annual Payments	\$10,909,009	\$10,909,009	\$10,560,216	\$10,560,216	\$10,759,527
Tier 3: CEPT O&M Avoided Costs	242,457,015	242,457,015	242,457,015	242,457,015	242,457,015
CEPT PAYGO/Debt Avoided Costs	<u>362,889,796</u>	<u>362,889,796</u>	<u>362,889,796</u>	<u>362,889,796</u>	<u>362,889,796</u>
Total PV Cost	\$605,346,812	\$605,346,812	\$605,346,812	\$605,346,812	\$605,346,812
Total Cost, Annual Payments	\$35,752,661	\$35,752,661	\$35,752,661	\$35,752,661	\$35,752,661
Water Produced (AF)	96,162	96,162	96,162	96,162	96,162
Gross Costs (Includes O&M, Capital, Grants and LRP)					
Total Costs NPV	\$2,729,362,903	\$2,731,309,085	\$2,457,535,244	\$2,449,200,361	\$2,743,641,152
Total Cost, Annual Payments	\$161,200,131	\$161,315,075	\$145,145,595	\$144,653,325	\$162,043,425
Total Cost: \$/AF (2011)	\$1,700	\$1,700	\$1,500	\$1,500	\$1,700
Total Cost: \$/Gallon (2011)	\$0.0052	\$0.0052	\$0.0046	\$0.0046	\$0.0052
Net Cost Tier 1 (Direct Wastewater System Savings)					
Total Costs NPV	\$1,777,396,804	\$1,779,342,987	\$1,505,569,145	\$1,497,234,263	\$1,791,675,053
Total Cost, Annual Payments	\$104,975,633	\$105,090,577	\$88,921,097	\$88,428,827	\$105,818,927
Total Cost: \$/AF (2011)	\$1,100	\$1,100	\$900	\$900	\$1,100
Total Cost: \$/Gallon (2011)	\$0.0034	\$0.0034	\$0.0028	\$0.0028	\$0.0034
Net Cost Tier 2 (Salt Credit Plus Tier 1 Savings)					
Total Costs NPV	\$1,592,690,717	\$1,594,636,899	\$1,326,768,662	\$1,318,433,779	\$1,609,499,925
Total Cost, Annual Payments	\$94,066,623	\$94,181,568	\$78,360,881	\$77,868,611	\$95,059,400
Total Cost: \$/AF (2011)	\$1,000	\$1,000	\$800	\$800	\$1,000
Total Cost: \$/Gallon (2011)	\$0.0031	\$0.0031	\$0.0025	\$0.0025	\$0.0031
Net Cost Tier 3 (Indirect Wastewater System Savings Plus Tier 1 and Tier 2 Savings)					
Total Costs NPV	\$987,343,905	\$989,290,088	\$721,421,850	\$713,086,968	\$1,004,153,114
Total Cost, Annual Payments	\$58,313,963	\$58,428,907	\$42,608,221	\$42,115,950	\$59,306,739
Total Cost: \$/AF (2011)	\$600	\$600	\$400	\$400	\$600
Total Cost: \$/Gallon (2011)	\$0.0018	\$0.0018	\$0.0012	\$0.0012	\$0.0018

* See section 8.4 for assumptions. The total costs were adjusted as noted to 2011 \$'s for comparison to the SDCWA untreated water costs.



Table 8-16. Financial Details for the Unfavorable Scenario

Item	Theme A1	Theme A2	Theme B1	Theme B2	Theme B3
O&M and Capital Debt					-
Interest from Reserve	40,515,384	40,756,326	36,991,977	37,156,991	40,385,393
Operation & Maintenance	1,757,803,600	1,753,642,189	1,612,278,853	1,599,768,756	1,799,893,592
Debt Service	<u>1,385,732,744</u>	<u>1,392,960,001</u>	<u>1,224,977,635</u>	<u>1,229,911,800</u>	<u>1,347,713,119</u>
Total PV Cost	\$3,103,020,960	\$3,105,845,864	\$2,800,264,511	\$2,792,523,565	\$3,107,221,318
Total Cost, Annual Payments	\$183,268,918	\$183,435,761	\$165,387,683	\$164,930,491	\$183,516,997
Capital (PAYGO Financed)					
PAYGO Financing	<u>357,032,668</u>	<u>358,816,714</u>	<u>315,338,882</u>	<u>316,565,050</u>	<u>346,633,018</u>
Total PV Cost	\$357,032,668	\$358,816,714	\$315,338,882	\$316,565,050	\$346,633,018
Total Cost, Annual Payments	\$21,086,867	\$21,192,235	\$18,624,372	\$18,696,791	\$20,472,649
Credits/Avoided Costs					
LRP Credit	<u>44,501,622</u>	<u>44,501,622</u>	<u>42,540,058</u>	<u>42,540,058</u>	<u>43,660,952</u>
Total PV Cost	\$44,501,622	\$44,501,622	\$42,540,058	\$42,540,058	\$43,660,952
Total Cost, Annual Payments	\$2,628,330	\$2,628,330	\$2,512,477	\$2,512,477	\$2,578,679
Tier 1: Wastewater O&M Avoided Costs	515,354,315	515,354,315	515,354,315	515,354,315	515,354,315
Wastewater PAYGO/Debt Avoided Costs	<u>436,611,784</u>	<u>436,611,784</u>	<u>436,611,784</u>	<u>436,611,784</u>	<u>436,611,784</u>
Total PV Cost	\$951,966,099	\$951,966,099	\$951,966,099	\$951,966,099	\$951,966,099
Total Cost, Annual Payments	\$56,224,498	\$56,224,498	\$56,224,498	\$56,224,498	\$56,224,498
Tier 2: Salt Credit	<u>184,706,087</u>	<u>184,706,087</u>	<u>178,800,483</u>	<u>178,800,483</u>	<u>182,175,128</u>
Total PV Cost	\$184,706,087	\$184,706,087	\$178,800,483	\$178,800,483	\$182,175,128
Total Cost, Annual Payments	\$10,909,009	\$10,909,009	\$10,560,216	\$10,560,216	\$10,759,527
Tier 3: CEPT O&M Avoided Costs	242,457,015	242,457,015	242,457,015	242,457,015	242,457,015
CEPT PAYGO/Debt Avoided Costs	<u>362,889,796</u>	<u>362,889,796</u>	<u>362,889,796</u>	<u>362,889,796</u>	<u>362,889,796</u>
Total PV Cost	\$605,346,812	\$605,346,812	\$605,346,812	\$605,346,812	\$605,346,812
Total Cost, Annual Payments	\$35,752,661	\$35,752,661	\$35,752,661	\$35,752,661	\$35,752,661
Water Produced (AF)	96,162	96,162	96,162	96,162	96,162
Gross Costs (Includes O&M, Capital, Grants and LRP)					
Total Costs NPV	\$3,415,552,006	\$3,420,160,956	\$3,073,063,335	\$3,066,548,557	\$3,410,193,384
Total Cost, Annual Payments	\$201,727,454	\$201,999,666	\$181,499,577	\$181,114,805	\$201,410,966
Total Cost: \$/AF (2011)	\$2,100	\$2,100	\$1,900	\$1,900	\$2,100
Total Cost: \$/Gallon (2011)	\$0.0064	\$0.0064	\$0.0058	\$0.0058	\$0.0064
Net Cost Tier 1 (Direct Wastewater System Savings)					
Total Costs NPV	\$2,463,585,907	\$2,468,194,857	\$2,121,097,236	\$2,114,582,458	\$2,458,227,285
Total Cost, Annual Payments	\$145,502,956	\$145,775,167	\$125,275,079	\$124,890,306	\$145,186,468
Total Cost: \$/AF (2011)	\$1,500	\$1,500	\$1,300	\$1,300	\$1,500
Total Cost: \$/Gallon (2011)	\$0.0046	\$0.0046	\$0.0040	\$0.0040	\$0.0046
Net Cost Tier 2 (Salt Credit Plus Tier 1 Savings)					
Total Costs NPV	\$2,278,879,820	\$2,283,488,770	\$1,942,296,753	\$1,935,781,975	\$2,276,052,157
Total Cost, Annual Payments	\$134,593,947	\$134,866,158	\$114,714,863	\$114,330,091	\$134,426,941
Total Cost: \$/AF (2011)	\$1,400	\$1,400	\$1,200	\$1,200	\$1,400
Total Cost: \$/Gallon (2011)	\$0.0043	\$0.0043	\$0.0037	\$0.0037	\$0.0043
Net Cost Tier 3 (Indirect Wastewater System Savings Plus Tier 1 and Tier 2 Savings)					
Total Costs NPV	\$1,673,533,008	\$1,678,141,958	\$1,336,949,941	\$1,330,435,163	\$1,670,705,346
Total Cost, Annual Payments	\$98,841,286	\$99,113,498	\$78,962,202	\$78,577,430	\$98,674,280
Total Cost: \$/AF (2011)	\$1,000	\$1,000	\$800	\$800	\$1,000
Total Cost: \$/Gallon (2011)	\$0.0031	\$0.0031	\$0.0025	\$0.0025	\$0.0031

* See section 8.4 for assumptions. The total costs were adjusted as noted to 2011 \$'s for comparison to the SDCWA untreated water costs.

8.5 Adaptability and Implementation

The implementation of this reuse plan will need to be adaptable to anticipated and unanticipated needs. Adaptability may be triggered based on financial constraints, changes in regulatory requirements, institutional coordination issues, favorable or unfavorable political and community support, and technical issues. The project implementation proposed below provides a number of key actions to help implement this reuse program and maximize adaptability to changing conditions.



Depending on the influencing forces, the pace and exact implementation may vary – for example the City may elect to pursue expanding or constructing new facilities to producing indirect potable reuse water for delivery to the San Vicente Reservoir. Another example is that the regulatory picture regarding direct potable reuse will become clearer as these projects progress. This may alter the approach, resulting in reduced piping to deliver water, but increased treatment and monitoring. The project implementation plan aims to lay these choices out in a way that can be adapted to meet the City’s and Stakeholder’s needs. The following details key issues that may affect adaptability through implementation:

- **Wastewater Flows.** Wastewater flows drive the amount of source water available for reuse. The wastewater totals are based on projections. As the City approaches build-out conditions, actual flows may be higher or lower. The diversity of the Integrated Reuse Alternative components and the inclusion of the strategically important Harbor Drive facility promote adaptability for all options.
- **Point Loma Plant Thresholds.** The treatment/cost thresholds for the Point Loma Plant may change over time due to advances in technology, or due to new regulatory permitting requirements. As these conditions develop, the total reuse of some projects may need to be adjusted upwards or downwards to maintain the ideal balance of cost/benefit. Updating these issues will likely be addressed in future master planning efforts.
- **Imported Water Costs.** Imported water costs have risen substantially in the past few years, well outpacing inflation rates. The SDCWA is projecting that above average rate impacts will continue in the near future. Imported water costs, particularly untreated water costs, are an important financial benchmark for new, local water supplies. If untreated water rates rise more than expected, future updates to this Study may adapt to develop even more reuse due to consumer pressure for lower cost water.
- **Direct Potable Reuse.** One of the biggest unknowns, and potentially the most impactful, is whether direct potable reuse will be allowed in California in the near future. SB918 mandated that CDPH “investigate the feasibility of developing uniform water recycling criteria for direct potable reuse” by December 31, 2016. If direct potable reuse is approved, it would directly integrate the advanced water purification facility output water into the potable water treatment plants (without going to San Vicente Reservoir for example), and also allow integration with the regional untreated water aqueduct system. If direct potable reuse is allowed, the Study approaches would most likely be adapted at the Harbor Drive stage. The Harbor Drive Plant discharge pipe length would likely be shortened to deliver the water to Lake Murray and the Alvarado (Potable) Water Treatment Plant.

8.5.1 Implementation Summary

Implementing the Integrated Reuse Alternatives involves a step-by-step process as shown on Figure 8-9. Although part of the implementation process includes common elements regardless of the alternative, it is important to note that the latter steps are affected by these earlier phase projects. Therefore, implementation considerations are important even during the first phase projects. This section summarizes the planned implementation process and the key considerations needed to successfully implement this important program.

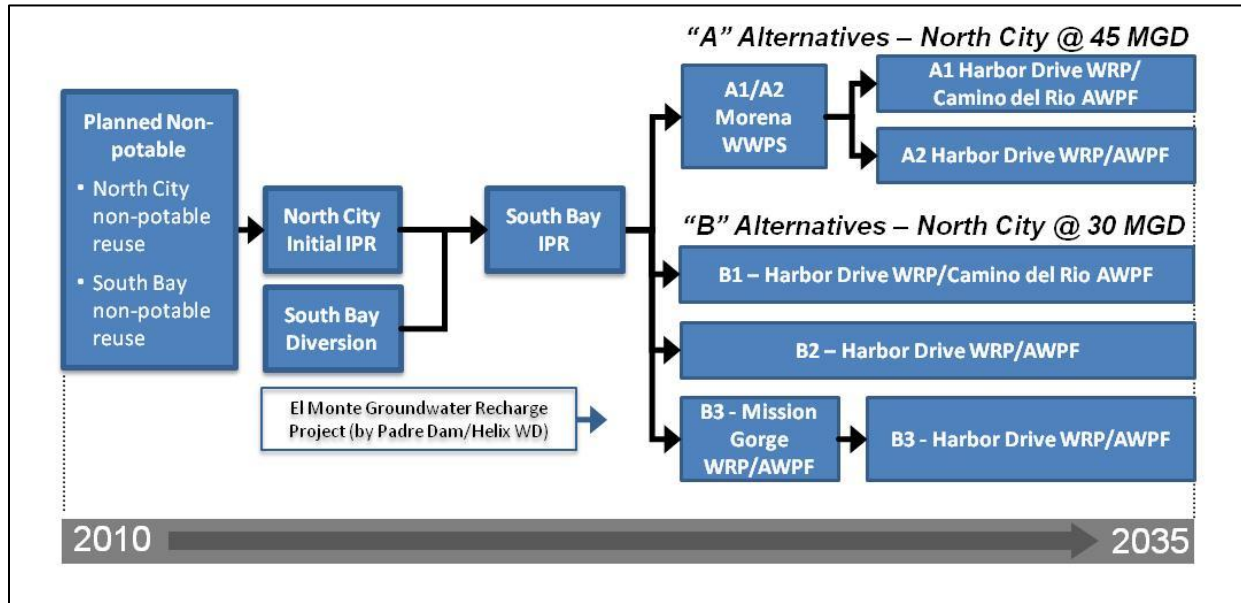

Figure 8-9. Reuse Plan Summary

The implementation plan summarizes the basic roadmap to complete the reuse plan.

Achieving the benefits identified in this report requires an investment. Some of these investments have already been started, such as the Water Purification Demonstration Project now operating at the North City Plant. To proceed to the next steps in this study, additional investments will be needed to plan and develop the program to a level of detail that can be designed, permitted and constructed. These investments are referred to as program implementation steps. The following sections organize these key implementation steps into a number of broad categories.

8.5.2 General

- Develop timeline for implementation steps outlined below.

8.5.3 Water Purification Demonstration Project/Permitting

The Water Purification Demonstration Project (Demonstration Project) and the San Vicente flow modeling are key steps of the public involvement and regulatory permitting processes to confirm the health and safety of the new water supply.

- Obtain Advanced Water Purification Facility water quality and San Vicente limnology model final results.
- Provide on-going public involvement and community outreach.
- Coordinate with CDPH and the Regional Water Quality Control Board on processes and permitting (whether through uniform criteria being developed by CDPH or project specific criteria).

- Promote advocacy by Stakeholder groups with CDPH and the Regional Water Quality Control Board.

8.5.4 Mayor and City Council

Support from the Mayor and City Council is essential to implement such an important program. While the reuse program appears to offer substantial cost savings to ratepayers (compared to upgrading the Point Loma Plant for the full-scale flows), support from policymakers to advance the program will be needed.

- Obtain Independent Rates Oversight Committee support.
- Obtain Natural Resources and Culture Committee approval.
- Obtain stakeholder advocacy support of the Study by the Metro JPA, Independent Rates Oversight Committee, environmental groups, and other interested parties.
- Obtain City Council approval.
- Coordinate implementation with broader water policy issues and programs.

8.5.5 Metro JPA Approval

As partners in the Metro System, support from the Metro JPA is also essential to implement such an important program. Support from JPA policymakers is needed to advance the program.

- Develop and finalize a cost sharing framework, as summarized below. This includes policy and legal issues, costs and consensus.
- Promote stakeholder advocacy in support of the Study by the City, Independent Rates Oversight Committee, environmental groups, and other interested parties.
- Obtain Policymaker support and accept the Study and the reuse program.

8.5.6 Financials/Policy

Fiscal responsibility is important for all parties. For Water and Wastewater ratepayers, there is an important choice required regarding whether to fund this water reuse plan or potentially fund full-scale improvements at the Point Loma Plant.

- Complete discussions on cost share framework concepts and agreements, clarify City and Participating Agency costs, and clarify sources for offset such as the salt credit.
- Provide comparative financial analyses with other alternative water sources (if desired).
- Determine/develop policy on local resource program funding from SDCWA/MWD.
- Determine SDCWA policy on regional supply benefits, interest in joint participation, and potential rate impacts/savings.
- Seek out and apply for grants.
- Develop rate impacts and a detailed financing plan.
- Provide funding and staff to move forward with the program implementation, including the activities needed for near-term and long-term projects.
- Develop policy on SBx7-7 stemming from new locally produced water supply.

8.5.7 Permitting

Implementing the reuse plan will require addressing key permitting activities:

- Point Loma Permitting. Continue permitting coordination amongst Stakeholders as part of the Point Loma Plant 301(h) Modified Permit process. These discussions are assumed to be related to the cost sharing discussions outlined above.
- Project Permitting. Identify, evaluate and obtain permits needed to complete the reuse projects.

8.5.8 Technical/Other

Implementing the reuse plan will require technical evaluations and engineering.

- **Reuse Program/wastewater planning process coordination.** On-going coordination between the proposed reuse program and wastewater planning efforts to refine facilities and costs in support of the cost sharing discussions and Point Loma permitting process.
- **North City treatment.** Determine the North City treatment approach (existing filters, feed source, recovery rates, electrolysis reversal unit's removal, and other technical design parameters).
- **Non-potable reuse demands and wastewater flow confirmation.** Continue to evaluate non-potable reuse demands and use trends; and wastewater flow generation. These totals will be important to finalize the size of indirect potable reuse projects.
- **New facility siting.** Develop detailed siting studies for new pump stations and treatment plants, including evaluation and confirmation of availability of the Harbor Drive and Camino del Rio sites.
- **Wastewater Treatment pilot testing.** Test high rate systems to develop area-specific values for clarifiers to be used in the design of treatment systems.
- **New conveyance facility alignments.** Perform alignment studies for new conveyance facilities.
- **SV8 Diversion to South Bay.** Update the SV8 Pump Station Predesign and Sweetwater River crossing. Coordinate efforts between the Recycled Water Study needs and the September 2011 Draft Wastewater Master Plan needs.
- **South Bay Plant.** Continue discussion and coordination on South Bay Plant issues, particularly sizing and timing needed for reuse based on recent revisions to the September 2011 Draft Wastewater Master Plan. Key coordination issues include South Bay timing (both from reuse and wastewater perspectives), and the biosolids approach strategy. This includes evaluating/determining whether biosolids will be treated at the South Bay Plant at a dedicated facility instead of continuing to send it to the Point Loma Plant and the MBC for treatment. These coordination items will aid in determining cost responsibilities as outlined in the financial implementation steps above.
- **South Bay indirect potable reuse delivery.** Perform detailed evaluation of the South Bay Plant expansion including pump station and delivery pipeline to Otay Lakes.
- **Otay Lakes operation.** Perform an Otay Lakes operational evaluation in relation to local runoff and indirect potable reuse operation to confirm flow rates and optimal project sizing.
- **Joint Project Evaluation.** Identify opportunities of joint projects, such as brine pipelines or indirect potable reuse delivery pipelines coordinated with other regional projects.
- **Mission Gorge Plant Evaluations.** Coordinate further discussion and evaluation on the merits of a joint plant with Padre Dam Municipal Water District in the Mission Gorge area (conceptualized in Alternative B3). Evaluate possible additional savings at the East Mission Gorge Pump Station and additional avoided facility savings in downstream facilities.
- **Groundwater updates.** Complete groundwater studies including evaluation of the San Diego Formation and San Diego River system for possible inclusion into future master planning efforts.

Update the status of other County groundwater studies including San Pasqual and Padre Dam Municipal Water District's studies.

- **Waste stream recovery.** Evaluate waste stream efficiency and recovery analysis to evaluate ways to further minimize waste streams and explore beneficial uses.
- **San Vicente regulatory limits and operational coordination.** Perform San Vicente analysis to evaluate maximum potential indirect potable reuse. If it is limited, determine options such as further evaluation of the San Diego formation or integration with other reservoirs. Coordinate reuse operational activities with other San Vicente operations after the dam raise is complete.
- **Regulatory update on minimum reservoir capacities.** Check assumptions on smaller sized reservoirs (Lakes Murray, Miramar and Jennings) once indirect potable reuse reservoir augmentation regulations are finalized.
- **SDCWA Coordination.** Coordinate with SDCWA on their Master Plan (currently underway), broader water policy support at the state level, and possible regional collaboration involving funding.
- **Peak Wet Weather Flow Strategies.** Continue to evaluate fail-safe disposal strategies under wet weather conditions, including equalization, live stream discharge, and CEPT-secondary effluent blending at the Point Loma Plant.

8.5.9 Cost Sharing Implementation Considerations

Recognizing that cost sharing would be an important step in implementing this Study, the City engaged the Study's Stakeholder group (which includes Participating Agency representatives) in an initial cost-sharing discussion. This discussion was held during Status Update Meeting No. 9 on March 29, 2011. A follow-up meeting with additional Participating Agency representatives was held on April 11, 2011. The follow-up meeting included a more detailed discussion of cost sharing concepts. It was anticipated that these concepts could become the framework for a cost-sharing agreement between the City and Participating Agencies. The following sections summarize concepts and key issues discussed.

8.5.9.1 Cost Sharing Concepts

Five framework concepts were presented at the April 11, 2011, cost-sharing concepts meeting.

- **Planned Wastewater System Expenses versus this Study.** This concept involves comparing the September 2011 Draft Wastewater Master Plan Capital Improvement Project plan costs with this Study's costs. To accomplish this, secondary treatment upgrade costs for 125 mgd were added to the wastewater system expenses to make both approaches comparable (i.e., both assumed secondary treatment would be required for the remainder of flow still going to the Point Loma Plant).
- **Water Expenses versus Wastewater Expenses.** This concept is similar to the cost-sharing approach used for North City and South Bay Plants, which included allocating the costs through secondary treatment upgrades to the wastewater system and costs beyond secondary treatment upgrades to the water system. Facility costs are identified as either benefitting the water system or the wastewater system.
- **Permit Mandate.** This concept assumed that the entire responsibility for the Recycled Water Study costs would be borne by the City's and Participating Agencies' wastewater customers. This would occur if a future Point Loma Plant permit would require implementing one of the plans contained in this Study.



- **50-percent/50-percent Split.** This concept recognizes that recycled water has significant benefits to both the water and wastewater systems and that splitting the benefits between the two systems is too qualitative to reach a fair, quantifiable split. This concept was considered a possible fit if consensus was not reached on the more detailed cost-share approaches.
- **Value Assessment.** This concept focused on adjusting the cost share to match the value of untreated water. Early in the implementation, recycled water costs will be higher than untreated water. The wastewater system would be responsible for paying the difference between untreated water costs and the recycled water costs. Over time, untreated water costs are anticipated to increase above the recycled water costs. At this time, the water system would bear all the costs of the recycled water system since the overall cost is lower than untreated water.

Participants refined the Coarse Framework Concepts described above into the refined approaches described below.

- **Cost Sharing Concept No. 1 - Planned Wastewater System Expenses vs. this Study.** This concept was maintained since it forms the baseline assumption that there may be sizable wastewater system costs unless offloading occurs at the Point Loma Plant. This concept was also considered important from a policy maker's perspective since it highlights ratepayer impacts.
- **Cost Sharing Concept No. 2 - Water Expenses vs. Wastewater Expenses.** This concept was based on the Value Assessment Concept described above, with two alternatives approaches.
 - **Concept 2A – Water vs. Wastewater (similar to previous North City Plant and South Bay Plant cost-sharing approach).** This approach is best outlined as follows:
 - Identify facility costs associated with water system benefits.
 - Identify facility costs associated with wastewater system benefits.
 - Identify facility costs where the benefits could arguably be for either the water or wastewater systems.
 - Negotiate the facility costs that are listed as a potential to be either a water system or wastewater system benefit.
 - **Concept 2B – Water vs. Wastewater (including value of water).** This approach follows Concept 2A except it includes capturing the value of the water produced in the cost sharing and may include some portion of the revenue generated by the water created as a credit back to the wastewater system.
- **Cost Sharing Concept No. 3 – Permit Mandate.** This concept was maintained similar to Concept No. 1 since it represents a potential regulatory/legal issue that is an important consideration for policy makers.

Lastly, the salt credit will need to be discussed regarding the benefits and how benefits are accounted for.

8.5.9.2 Other Cost Sharing Considerations

Two initial coarse framework concepts were dropped from further refinement; however, it is important to note a few considerations on these approaches. The 50 percent/50 percent split was considered to lack a strong basis, but it was noted that this consideration assumed that an agreement would be met on the more detailed cost-share concepts. If an agreement cannot be reached on a detailed cost-share concept then the 50 percent/50 percent split could be considered. Orange County Water District and Orange County Sanitation District successfully used this approach for their Groundwater Recovery System project when an agreement was not reached using other methods. In addition, the value approach discussed as a coarse concept was not discounted, but incorporated into the water/wastewater system cost-sharing concept 2B. Ultimately, the cost-share discussion will require policy maker input, and this framework is intended to initiate the process.

8.5.10 Point Loma Plant Improvements During Implementation

The City, the Participating Agencies, the Environmental Protection Agency, and the Stakeholder group will be key participants in addressing the Point Loma Plant as the reuse plan is implemented. The plan assumes that any secondary treatment upgrades (if required) at the Point Loma Plant would be determined during the implementation stage of the project. This approach would allow determining the actual solids mass emission rates occurring after the new reuse projects offload flows to the Point Loma Plant and after solids are removed and sent to the Metropolitan Biosolids Center. Although the study looked at both secondary treatment and CEPT approaches at the Point Loma Plant, making a determination on CEPT would clarify the avoided facilities savings element associated with the financial evaluation section above.

8.5.11 Harbor Drive Facility Implementation

The Harbor Drive site is located at the confluence of the City's two largest interceptor sewers: the North Metro Interceptor and the South Metro Interceptor. At this location, a majority of the wastewater generated within the Metro System collects before being pumped to the Point Loma Plant. The City owns approximately 77 acres at the site, 22 of which could potentially be available for a treatment facility. Currently, the site contains a park, Pump Station No. 2, the City's Environmental Monitoring & Technical Services Division facility, and firefighter training facilities.

A new police and firefighter training center is currently planned for a portion of the site. Discussions have begun to determine if the police and firefighter training facilities can be located elsewhere. The City evaluated the potential to locate the treatment facility at another location and determined that no other sites are feasible (Appendix E); therefore, it is critical the City reserve this site for a future Harbor Drive treatment facility.

A membrane bioreactor (MBR) treatment process was selected for the Harbor Drive site because of land constraints. The MBR process requires less land than conventional processes. A preliminary review of the site indicated a 60-mgd MBR facility could potentially fit within the site; however, a more detailed evaluation is required to determine the maximum facility capacity that would fit within the site limits. If it is not possible to co-locate an AWPf at the Harbor Drive site, it is possible to pump tertiary effluent produced by an MBR facility to another location for advanced treatment.

The site is near the airport, San Diego Bay, and several waterfront hotels. This places strict height restrictions on structures and requires ample odor control and aesthetic treatment. In addition, groundwater must be taken into consideration during design and construction because of the proximity to the bay. A detailed siting evaluation that includes facility layouts is needed.

In the event the Harbor Drive facility is not available, the level of indirect potable reuse could be significantly reduced and the cost of producing the same amount of treated water could significantly increase. Options include further investigation of alternative sites, additional diversions to South Bay, or other reuse options evaluated in the Area Concepts. While it is possible to replace the Harbor Drive project with other projects, they will likely be more expensive and impactful to complete.

8.5.12 Pipeline Phasing between the North City Plant and the San Vicente Reservoir

Selection of the pipeline from the North City Plant to the San Vicente Reservoir is critical. The initial North City indirect potable reuse project requires the indirect potable reuse water delivery pipeline be sized between the North City Plant and the San Vicente Reservoir. The pipe size is dependent upon a decision about future steps and whether the ultimate pipe size is constructed to maximize cost savings. If Integrated Reuse Alternative A1 or A2 is selected, a larger pipe is needed. Additionally, the decision must be made whether or not to construct a larger pipeline from Mission Gorge to San Vicente in anticipation of a Harbor Drive or

Mission Gorge project. If **direct** potable reuse becomes viable in the future, then the Harbor Drive facility will likely convey advanced purified water to the Alvarado Water Treatment Plant, and a larger-diameter pipe from Mission Gorge to San Vicente would not be needed.

This is a critical decision that will have cost impacts. A comprehensive plan is required before building the pipeline so that the decisions about future facilities have been made prior to design and construction. A future update to the regulatory considerations regarding direct potable reuse may aid the decision process.

8.6 Conclusion

Overall, the Integrated Reuse Alternatives presented in this Study achieves the Study's goals, provides a bold vision for future water reuse in the Metro Service Area, and provides potential savings to ratepayers. The Study's Stakeholders provided valuable opinions and diverse viewpoints that added value to the process and the alternatives developed. While water reuse has been evolving in San Diego over the past few decades, the region's master plans have helped guide decision makers with a focus on making good investments, while still being flexible to adapt to future changes. This Study endeavors to continue this tradition, and be looked upon as a milestone that helped provide long-term water sustainability to the San Diego region.

9. STUDY OUTREACH AND APPROVALS

The final Stakeholder meeting was held on March 22, 2012 to review and discuss comments submitted by the group, and to finalize the Study report. Representatives from all Stakeholder groups were present. The group agreed that it had been a productive session, that the final document reflected their respective views, and that the process had been inclusive. Following this meeting, the Study team incorporated the final set of comments into the Study document. The Stakeholders requested that the City communicate to them the schedule of any Study presentations they were making so that they could attend if their schedules permitted.

At the request of the Participating Agencies, a presentation on the Study was made to the elected officials of the Metro JPA (Metro Commission/JPA) on May 3, 2012. The Metro Commission/JPA responded favorably to the presentation, asked a number of questions, and provided the team with feedback and suggestions that were subsequently incorporated into the presentation materials. The Metro Commission/JPA requested that the team attend their June meeting to address any additional questions they may have. Representatives from environmental stakeholder groups were also present at this meeting.

On May 21 and 23, respectively, the project team made a presentation on the Study to IROC, and the Natural Resources & Culture Committee (NR&C). The Study report was favorably received by IROC which voted to approve it. A number of speakers spoke in favor of the Study, including representatives from San Diego Coastkeeper, Surfrider Foundation and the business community. The speakers told committee members that they supported the study and its outcome, encouraged Council to move forward with implementation, and spoke of the rising cost of imported water and the importance of a local water supply. NR&C committee members asked a number of questions which were answered at the meeting and in a follow up memorandum. The NR&C voted unanimously to accept the Study.

On June 7, 2012, project team members attended the Metro Commission/JPA meeting. The Metro Commission/JPA unanimously approved a letter to the City formally accepting the Study, and acknowledged that the process was very collaborative (Appendix L). In the letter, the Metro JPA indicated an interest in continuing to work cooperatively with the City on stated Study objectives and implementation activities identified in the report.

On June 19, 2012, City Study team members gave a presentation on the Study to regional water agency general managers attending their monthly meeting convened by the San Diego County Water Authority. The General Managers asked questions and were appreciative of the presentation.

The Study was presented at the July 17, 2012 City Council meeting. Stakeholders representing San Diego Coastkeeper, Surfrider Foundation, IROC, the Metro JPA and TAC all spoke in favor of the Study. San Diego Coastkeeper and Surfrider speakers told the City Council that the Study met their expectations, they were pleased with the final result, and that it fulfilled the City's Cooperative Agreement obligation (Appendix A). Other speakers commented on the collaborative stakeholder process and spoke favorably of the Study meeting its objectives. City Council members were appreciative of Stakeholder involvement, expressed thanks to those in attendance, and voted unanimously to accept the Study (Appendix M).

This page intentionally left blank.



SAN DIEGO RECYCLED WATER STUDY

CONTACTS

The project team consisted of City staff from the Public Utilities Department, and a consulting team from Brown and Caldwell, Black & Veatch, and CDM.



City of San Diego Primary Project Team

Marsi Steirer
Deputy Director
City of San Diego
msteirer@sandiego.gov
(619) 533-4112
600 B Street, Suite 700, MS 907
San Diego, CA 92101-4587

Amy Dorman, P.E.
Senior Project Manager
City of San Diego
adorman@sandiego.gov
(619) 533-5248
600 B Street, Suite 700, MS 907
San Diego, CA 92101-4587

Amer Barhoumi, P.E.
Project Manager
City of San Diego
abarhoumi@sandiego.gov
(619) 533-4186
600 B Street, Suite 700, MS 907
San Diego, CA 92101-4587

Primary Supporting Team:
Jennifer Casamassima
Fabiola Amarillas
Rey Novencido



Consultant Primary Project Team

Victor Occiano, P.E.
Co-Project Manager
Brown and Caldwell
vocciano@brwncald.com
(858) 571-6715
9665 Chesapeake, Suite 201
San Diego, CA 92123

James Strayer, P.E.
Co-Project Manager
Black & Veatch
strayerjj@bv.com
(760) 525-6230
300 Rancheros Drive, Suite 250
San Marcos, CA 92069

Primary Supporting Team:
Nick Kanetis, Brown and Caldwell
Kyle Sandera, Brown and Caldwell
Anil Pai, Brown and Caldwell
Seval Sen, Brown and Caldwell
Kevin Davis, Black & Veatch
David Cover, Black & Veatch
Ann Bui, Black & Veatch
Alberto Morales, Black & Veatch
Jennifer Thompson, CDM
Kelley Dyer, CDM



This page intentionally left blank.



SAN DIEGO RECYCLED WATER STUDY

GLOSSARY

Acre-foot (AF): A unit commonly used for measuring the volume of water, equal to the quantity of water required to cover one acre to a depth of one foot. An acre-foot is 325,851 gallons and is considered enough water to meet the needs of two families of four for one year.

Acre-feet per year (AFY): The amount of water (in acre-feet) used, bought or produced in one year. City of San Diego Assembly on Water Reuse: American Assembly-style workshop that brought together diverse stakeholders to examine public policy questions and recommend action.

Advanced Treatment: Additional treatment provided to remove suspended and dissolved substances after conventional secondary treatment. Often, this term is used to mean additional treatment after tertiary treatment for the purpose of further removing contaminants of concern to public health. This may include membrane filtration, reverse osmosis (RO), advanced oxidation, and disinfection with ultraviolet light (UV) and hydrogen peroxide (H₂O₂).

Advanced Water Purification Facility (AWPF): A treatment facility that utilizes advanced treatment to treat tertiary water.

Aquifer: A geologic formation that stores water and yields significant quantities of water to wells or springs.

Area Concepts: A term used to describe conceptual reuse opportunities developed for a specific area of the Metro System service area.

Augmentation: The process of adding recycled water that has received advanced treatment to an existing untreated water supply (such as a reservoir, lake, river, wetland, and/or groundwater basin) that could eventually be used for drinking water after further treatment.

Annual Average Daily Flow with 10-year Return Event (AADF). The AADF 10-year storm condition used in this Study is based on 2050 wastewater flows, represents the amount of wastewater generated over one year, and contains a wet weather component based on a 10-year return period. This flow condition was peaked to determine the peak wet weather flow condition used in sizing the Point Loma and South Bay Plants during critical flow conditions.

Avoided Costs: The cost savings that may accrue to a water provider if a given water reuse project delays or eliminates the need for a water or wastewater system improvement project.

Beneficial Use (of water): A use of water resulting in appreciable gain or benefit to the user, consistent with state law, which varies from one state to another. In California, beneficial uses of waters of the state that may be protected against quality degradation include, but are not necessarily limited to, domestic, municipal, agricultural, and industrial supply, power generation, recreation, aesthetic enjoyment, navigation, as well as preservation and enhancement of fish, wildlife, and other aquatic resources or preserves. (Water Code, Section 13050(f)).

Biochemical Oxygen Demand (BOD): A widely used parameter used to determine the level of organic pollution in a sample of water. It is the measurement of dissolved oxygen used by microorganisms to biochemically oxidize organic matter in a water sample in 5 days at 20 degrees Celsius.

Blending: Mixing or combining one water source with another.



Caltrans: California Department of Transportation

CDPH: California Department of Public Health

Chemically Enhanced Primary Treatment (CEPT): The process by which chemicals are added to primary sedimentation basins causing the suspended particles to clump together and settle faster, thereby enhancing treatment efficiency, measured as removal of solids, organic matter and nutrients from the wastewater. The chemicals utilized in CEPT are the same ones commonly added in potable water treatment. This is the level of treatment currently employed at the Point Loma Wastewater Treatment Plant.

City: City of San Diego

Coarse Screening Session: A work session held August 2-3, 2010 that was attended by the City, the City's consultant team, the Study's independent technical reviewer, and JPA representatives. The focus of the session was to evaluate non-potable and indirect potable reuse opportunities throughout the region.

Contaminant: An undesirable substance not normally present or an unusually high concentration of a naturally occurring substance in water, soil or other environmental medium.

Contaminants of Emerging Concern (CECs): Chemicals are being discovered in water that previously had not been detected or are being detected at levels that may be significantly different than expected. These are often generally referred to as "contaminants of emerging concern" (CECs) because the risk to human health and the environment associated with their presence, frequency of occurrence, or source may not be known. EPA is working to improve its understanding of a number of CECs, particularly pharmaceuticals and personal care products (PPCPs) and perfluorinated compounds among others. (*EPA Website, <http://water.epa.gov/scitech/cec/>*)

Costs: The capital and operating expenses of constructing and operating a water reuse project, typically consisting of (1) capital costs, the initial expenditures to design and construct project facilities; and (2) operating costs, the ongoing annual expenses associated with operating the project, including labor, material, and energy costs.

Council: The City Council of San Diego

CWA: Federal Clean Water Act

Demineralization: A process that removes dissolved minerals from water. In some cases, a percentage of water is demineralized and blended back in with the original source water to dilute the level of dissolved solids in the source water.

Detention Time: In storage reservoirs, the length of time water will be held before being extracted from the reservoir for treatment.

Direct Injection: Injecting recycled water through an injection well directly into a groundwater basin. If the water will later be used for drinking, the recycled water will receive advanced treatment prior to injection.

Direct Potable Reuse: The planned introduction of advanced purified water either directly into a public water system, or into an untreated water supply, immediately upstream of a water treatment plant.

Disinfection: Removal, destruction or inactivation of any harmful microorganism

Disinfection By-Products: Compounds formed when chlorine combines with naturally occurring or pollution-derived organic, carbon-based materials, such as the acids from soils or decaying vegetation and bromide (salt).

Drinking Water: See "Potable Water."

Dry Weather Flow (DWF). The DWF condition used is based on 2035 wastewater flow projections and represents the amount of wastewater generated over one year without any consideration of the wet weather component (infiltration and inflow). This flow condition was used to size recycling facilities that are upstream of the Point Loma Wastewater Treatment Plant and that have no outfall.

Endocrine Disrupting Compounds (EDCs): Chemicals that can interfere with the normal hormone function in humans and animals.

EPA: United States Environmental Protection Agency

Eutrophication: The process by which a body of water acquires a high concentration of nutrients, especially phosphates and nitrates, promoting excessive growth of algae. As the algae die and decompose, high levels of organic matter and the decomposing organisms deplete the water of available oxygen, causing the death of other organisms, such as fish. Eutrophication is a natural, slow-aging process for a water body, but human activity greatly speeds up the process. (*USGS Website*)

Fine Screening Session: A work session held October 19, 2010 that was attended by the City, the City's consultant team, the Study's independent technical reviewer, and JPA representatives. This work session focused on refining the Area Concepts into the final integrated reuse alternatives.

Firm Supply: A water supply is considered firm if it is a reliable source for a community, either by legal rights or by natural availability. Recycled water is usually considered to be a firm supply as its source remains available even during dry years.

Framework Planning Session: A work session held on March 2, 2010 that was attended by the City, the City's consultant team, and the Study's independent technical reviewer. This work session was held to align the City, the consultant team, and stakeholders on key project issues, processes, and future steps.

Groundwater: Water beneath the Earth's surface that could supply wells or natural springs.

Groundwater Basin: A groundwater reservoir, defined by an overlying land surface and the underlying aquifers that contain water stored in the reservoir. In some cases, the boundaries of successively deeper aquifers may differ and make it difficult to define the limits of the basin.

Groundwater Recharge: Naturally or artificially adding water back into a groundwater basin by allowing the water to seep through the ground or by injection.

Grove Avenue Pump Station (GAPS): A pump station located in the South Bay that conveys wastewater to the South Bay Water Reclamation Plant.

Hale Avenue Resource Recovery Facility (HARRF): An 18 mgd wastewater treatment facility owned and operated by the City of Escondido.

Harbor Drive Plant: Refers to a new treatment facility conceptualized during this Study. The proposed location is on Harbor Drive near Pump Station No. 2.

Helix: Helix Water District

IBWC: International Boundary and Water Commission.

Imported Water: Water transported from one region or area to another.



Indirect Potable Reuse: Indirect potable reuse is the planned use of advanced purified water for replenishment of a groundwater basin or an aquifer that has been designated as a source of water supply for a public water system, or the planned placement of recycled water into a surface water reservoir used as a source of domestic drinking water supply.

Infill: Increase water reuse demand through connection of large users within 1,320 feet (quarter-mile) of the existing reclaimed water pipeline.

Integrated Reuse Alternatives: Regional recycled water plans developed by combining Area Concepts. These alternatives were developed for policy makers to review, examine and debate as part of establishing the course for reuse in the region. The Integrated Reuse Alternatives were formed based on the project goals established by the project stakeholders.

JPA: The San Diego Metropolitan Wastewater Joint Powers Authority. A coalition of municipalities and special districts in San Diego County that share in the use of the City of San Diego's region wastewater system. The JPA member agencies are the cities of Chula Vista, Coronado, Del Mar, El Cajon, Imperial Beach, La Mesa, National City and Poway; the Lemon Grove Sanitation District; the Padre Dam Municipal and Otay Water Districts; and the County of San Diego (on behalf of the Winter Gardens Sewer Maintenance District, and the Alpine, Lakeside and Spring Valley Sanitation Districts).

Mass Emission Rate (MER): The rate of discharge of a pollutant expressed as a weight per unit time, usually as pounds or kilograms per day or metric tons per year .

MCL: Maximum Contaminant Level as defined in the EPA Drinking Water Standards.

Membrane Bioreactor (MBR): A type of biological wastewater treatment process that uses membranes to filter the wastewater.

Metropolitan Biosolids Center (MBC): The City of San Diego's solids processing facility located north of State 52 and adjacent to the Miramar Landfill.

Metro System: The Metropolitan Wastewater System.

MG: Million gallons.

MGD: Million gallons per day.

Microfiltration (MF): The separation or removal from a liquid of particulates and microorganisms in the size range of 0.1 to 2 microns in diameter. (A micron is a millionth of a meter. A sheet of ordinary 20-weight copier paper is about 90 microns thick.)

Mission Gorge Plant: Refers to a new treatment facility conceptualized during this Study that could either be located near the East Mission Gorge Pump Station or at the Padre Dam Water Reclamation Facility.

Multi-Barrier Approach: Treatment barriers designed to remove various types of contaminants using independent processes, insuring that treatment will not be compromised if any process were to fail.

Multiple Treatment Barriers: Each barrier is designed to provide substantial protection with redundant barriers for each type of treatment. A requirement for multiple barriers assures the overall water treatment process will remain effective if one treatment barrier were to fail.

MWD: Metropolitan Water District of Southern California.

National Pollutant Discharge Elimination System (NPDES): The program established by the Federal Clean Water Act that requires all sources of pollution discharging into any “waters of the United States” to obtain a permit issued by the Environmental Protection Agency or a state agency authorized by the federal agency. The NPDES permit lists permissible discharges and/or the level of cleanup technology required for wastewater.

North City Plant: The abbreviated name for the North City Water Reclamation Plant, a water reclamation plant in the Eastgate Mall area, bordered by Interstate 805 to the west, Miramar Road to the south and Eastgate Mall Road to the north, and an open wildlife preserve to the east. The plant is owned and operated by the City of San Diego.

North City Water Reclamation Plant: See North City Plant.

Non-potable Recycled Water: Synonymous with Non-potable Reclaimed Water, State of California Title 22 Water, and tertiary treated water. Non-potable recycled water is a form of water reuse that includes primary, secondary and tertiary treatment to produce water suitable for a variety of applications, most notably for landscaping irrigation and industrial uses. Further treatment is required for integration with drinking water systems – see indirect potable reuse.

NRC: National Research Council

NWRI: National Water Research Institute

O&M: Operation and Maintenance

Ocean Outfall: A large pipeline used to dispose of treated wastewater offshore.

OPRA: Federal Ocean Pollution Reduction Act.

Otay: Otay Water District.

Padre Dam: Refers to the Padre Dam Municipal Water District.

Participating Agency: A JPA member agency. See “JPA”.

Pathogens: Disease-causing organisms (generally viruses, bacteria, protozoa, or fungi).

Peak: An identified period of time when the maximum amount of water is used or the maximum amount of wastewater is measured or received at a treatment plant (typically during wet weather periods).

Peak Wet Weather Flow (PWWF). The 10-year return PWWF condition used in this Study is based on 2050 wastewater flow projections and is determined by applying a peaking factor to the 10-year return AADF to obtain the peak daily flow occurring during the 10-year return event (i.e., AADF is the annual average flow including the wet weather return period and PWWF is the peak daily flow during the return event). This flow condition applies to the strategy and design of the Point Loma and South Bay Plants to handle a peak wet weather event.

Potable Water: Synonymous with drinking water. Specifically, fresh water that meets the level of quality as established in the EPA Drinking Water Standards.

Poway: City of Poway

PPCPs: Pharmaceuticals and personal care products.

Preliminary Treatment: The first major stage of treatment encountered by domestic wastewater where rags, screenings and grit are removed.



Primary Treatment: The removal of particulate materials from domestic wastewater, usually by allowing the solid materials to settle as a result of gravity.

Public Utilities Department (PUD): The City department responsible for the management and operation of the water and wastewater facilities owned by the City.

Pump Station No. 1 (PS1): A City wastewater pump station located on Harbor Drive near National City. This pump station pumps wastewater from the South Bay area to PS 2.

Pump Station No. 2 (PS2): A City wastewater pump station located on Harbor Drive just west of San Diego International Airport. This pump station pumps wastewater from the Metro System collection area to the Point Loma Plant.

Purified, Advanced Purified, or Advanced Treated Water: Purified, advanced purified, or advanced treated water undergoes advanced treatment processes to convert non-potable recycled water to a highly purified water quality, suitable for augmentation to an untreated drinking water source. Advanced purified water is currently used for indirect potable reuse projects.

Reclaimed Water: The end product of wastewater reclamation that meets water quality requirements for biodegradable materials, suspended matter, toxicants, and pathogens. Reclaimed water is sometimes another name for recycled water.

Recycled Water: Reclaimed water that meets appropriate water quality requirements and is reused for a specific purpose.

Recycled Water Master Plan (RWMP): Refers to the City of San Diego Recycled Water Master Plan. The update of this plan was developed in conjunction with this Study.

Repurified Water: Recycled water treated to an advanced level suitable for augmentation to a drinking water source.

Residence Time: See “Detention Time.”

Reverse Osmosis (RO): A common water filtration process that uses a semi-permeable membrane which allows water to pass through it, while removing contaminants.

Regional Water Quality Control Board (Regional Water Boards): Refers to the Region 9 Board of the California State Water Resources Control Board, which includes the San Diego Region. The RWQCB develops basin plans for the San Diego hydrologic areas, govern requirements/issue waste discharge permits, take enforcement action against violators, and monitor water quality.

SANDAG: San Diego Association of Governments.

SDCWA: San Diego County Water Authority.

Secondary Treatment: Treatment following primary treatment. Removal of biodegradable organic matter and suspended solids from wastewater.

Senate Bill 918 (SB 918): A California Senate Bill approved in 2010 that requires the California Department of Public Health to adopt uniform water recycling criteria for groundwater recharge by December 31, 2013, develop and adopt uniform water recycling criteria for surface water augmentation by December 31, 2016, and investigate and develop a report on the feasibility of direct potable reuse by December 31, 2016.

Soil-Aquifer Treatment: The process of water being purified by percolating through soil and into an underground aquifer.

South Bay Plant: Also known as the South Bay Water Reclamation Plant, a water reclamation plant in the South Bay owned and operated by the City of San Diego.

South Bay Water Reclamation Plant: See South Bay Plant.

Stakeholders: Individuals and organizations who are involved in or may be affected by a proposed action, such as construction and operation of a water recycling project.

Status Update Meetings: Meetings held every two months throughout the Study to update Stakeholders on the Study's progress and findings, and to solicit input from Stakeholders.

Study: City of San Diego Recycled Water Study.

Supply Reliability: The reliability of the City's combined sources of supply of water under a variety of hydrologic and other conditions.

Tertiary Treatment: Treatment beyond secondary treatment typically involving the removal of residual particulate matter by granular media, surface, or membrane filtration.

Title 22 Treatment (Title 22): A method of tertiary wastewater treatment approved by DHS for many water reuse applications. Title 22, Chapter 4 of the California Code of Regulations, outlines the level of treatment required for allowable uses for recycled water, including irrigation, fire fighting, residential landscape watering, industrial uses, food crop production, construction activities, commercial laundries, road cleaning, recreational purposes, decorative fountains, and ponds.

Total Dissolved Solids (TDS): A measure of the amount of material dissolved in water (mostly inorganic salts). An important use of the measure involves the examination of the quality of drinking water.

Total Suspended Solids (TSS): All particles suspended in water which will not pass through a 0.45 micron glass-fiber filter.

Ultrafiltration (UF): A membrane filtration process that falls between reverse osmosis (RO) and microfiltration (MF) in terms of the size of particles removed. UF removes particles in the 0.002 to 0.1 micron range, and typically removes large organic molecules, while allowing smaller molecules to pass.

Ultraviolet Treatment (UV): The use of ultraviolet light for disinfection.

Uninterruptible Water Supply: Indirect potable reuse water is considered uninterruptible because it is not influenced by drought, water rights, or other supply interruptions such as the decision to decrease Southern California water supply because of endangered species in the California Bay-Delta.

Untreated Water (sometimes referred to as Raw Water): Water that is collected and stored in local surface water reservoirs and groundwater basins prior to treatment at a potable (drinking) water treatment plant. Untreated water examples include Colorado River water, water from the California Bay-Delta, and runoff from local rainfall.

Wastewater: Wastewater is generally used to describe sewage that comes from homes, industry or businesses. Wastewater is collected and treated at wastewater treatment plants. In San Diego, some wastewater is currently reclaimed as non-potable recycled water; however, the majority is treated and discharged to the ocean. Wastewater is needed for water reuse. Wastewater does not include stormwater in San Diego. Stormwater is collected in separate systems and typically not treated before discharge to streams and the ocean.

Wastewater Master Plan (WWMP): Refers to the City of San Diego, September 2011 Draft Metropolitan Wastewater Plan.



Water Purification Demonstration Project (WPDP): A project currently underway at the City's North City Plant that is evaluating advanced treatment technologies to help determine the feasibility of reservoir augmentation in San Diego. A study of the San Vicente Reservoir is also being conducted to test the key functions of reservoir augmentation and to determine the viability of a full-scale project. No purified water will be sent to the reservoir during the demonstration phase.

Water Reclamation: (1) The treatment of water of impaired quality, including brackish water and seawater, to produce a water of suitable quality for the intended use; and (2) A term synonymous with water recycling.

Water Recycling: The process of treating wastewater for beneficial use, storing and distributing recycled water, and the actual use of recycled water. Also see Water Reuse.

Water Reuse: Water reuse is a broad term used to describe the process of converting wastewater to a valuable water resource through treatment processes. Water reuse includes non-potable recycled water development and indirect potable reuse involving integration with drinking water supplies. Synonymous with water recycling.

Water Reuse Study: Refers to the 2005 City of San Diego Water Reuse Study.

Wetland: An area periodically inundated by surface water or groundwater. Wetlands support plant and animal life, filter pollutants in stream courses, provide flood control and erosion prevention, and may provide recreational opportunities.

Wholesale Customer: A water agency or utility that purchases non-potable recycled water from the City and then sells it to customers within their own service area.

SAN DIEGO RECYCLED WATER STUDY

LIMITATIONS

This document was prepared solely for City of San Diego, Public Utilities Department in accordance with professional standards at the time the services were performed and in accordance with the contract between City of San Diego, Public Utilities Department and Brown and Caldwell dated July 21, 2009. This document is governed by the specific scope of work authorized by City of San Diego, Public Utilities Department; it is not intended to be relied upon by any other party except for regulatory authorities contemplated by the scope of work. We have relied on information or instructions provided by City of San Diego, Public Utilities Department and other parties and, unless otherwise expressly indicated, have made no independent investigation as to the validity, completeness, or accuracy of such information.



This page intentionally left blank.



REFERENCES

- Barhouni, Amer and Wong, Pete, Secondary Treatment Siting Analysis, The City of San Diego, 2007.*
- Clean Water Program, Project Report for modifications to the Metropolitan Sewerage System, Recommended Plan, Volume IX of IX Volumes, May 1990.*
- Clean Water Program Guidelines, Volume VIII of X Volumes, Program Guidelines for Design Consultant, Appendix D Design Guidelines Wastewater Flow and Load Projections, The City of San Diego, April 1995.*
- Metcalf & Eddy, Wastewater Engineering Treatment and Reuse, McGraw-Hill, New York, 2003, 96-97.*
- Metcalf & Eddy, Water Reuse Issues, Technologies, and Applications. 1997.*
- Metropolitan Sewerage System Projected Flow and Strength Report – FY10, The City of San Diego, February 2010.*
- Draft Metropolitan Wastewater Master Plan, The City of San Diego, September 2011.*
- Draft Metropolitan Wastewater Plan, The City of San Diego, June 2006.*
- PBS&J, City of San Diego 2005 Water Reuse Study, The City of San Diego, 2006.*
- A Plain English Guide to the EPA Part 503 Biosolids Rule, by Michael B. Cook, Diane Pub. Co., August 2004*
- State Water Resources Control Board, Science Advisory Panel on Chemicals of Emerging Concern in Recycled Water, June 30, 2010, Final Panel Report, Communications Fact Sheet*
- National Water Research Institute (NWRI). Final Report of the May 11-12, 2009, Meeting of the Independent Advisory Panel for the City of San Diego Indirect Potable Reuse/Reservoir Augmentation Project. August 11, 2009. Fountain Valley, California.*

This page intentionally left blank.



APPENDIX A: COOPERATIVE AGREEMENT



This page intentionally left blank.

COOPERATIVE AGREEMENT

This Cooperative Agreement ("Agreement") is entered into this 17th day of ~~January~~ ^{February}, 2009, by and between San Diego Coastkeeper ("Coastkeeper"), the San Diego Chapter of Surfrider Foundation ("Surfrider"), and the City of San Diego (the "City"), a municipal corporation, individually referred to herein as "Party" and collectively as "Parties."

RECITALS

- A. Whereas, Coastkeeper and Surfrider have expressed concern over the City's application for a variance from secondary treatment requirements at the Point Loma Wastewater Treatment Plant (the "Waiver") and have litigated past Waiver issuances; and,
- B. Whereas, Coastkeeper and Surfrider have proposed that the City take a long-term view of its wastewater treatment and conveyance infrastructure and conduct a study to identify opportunities to increase recycling of wastewater and minimize discharges of treated sewage from the Point Loma Wastewater Treatment Plant; and,
- C. Whereas, by letter dated December 2, 2008, Region IX of the United States Environmental Protection Agency (the "EPA") tentatively approved the City's application for a Waiver under sections 301(h) and 301(j)(5) of the Clean Water Act; and,
- D. Whereas, the EPA's tentative decision indicates the City needs to pursue additional water reclamation and reuse projects, including those which demand a year-round supply of reclaimed water, to maintain long term compliance with mass emission permit limits for suspended solids; and,
- E. Whereas, the City, Coastkeeper and Surfrider recognize that studying the possibility of significantly reducing wastewater flows to the Point Loma Wastewater Treatment Plant and increasing wastewater recycling could benefit San Diego residents and the environment, and the Parties desire to cooperate in investigation of these opportunities; and,
- F. Whereas, in consideration of these recitals and for good and valuable consideration, the receipt and sufficiency of which are hereby acknowledged, the City, Coastkeeper, and Surfrider hereby set forth their mutual covenants and understandings as follows:

AGREEMENT

ARTICLE I – CITY'S RESPONSIBILITIES

1.1 Study of Wastewater Recycling – Scope of Work. The City shall, in coordination with Coastkeeper and Surfrider, prepare and execute a Scope of Work for the preparation of a city-wide assessment ("Study") of its wastewater collection and treatment system. The goal of the Study shall be to identify opportunities within the City's system to maximize recycling and reclamation of wastewater for potable and non-potable uses. The Scope of Work shall at a

minimum include a review of existing and currently proposed infrastructure, discussion of how much wastewater can feasibly be diverted from the Point Loma Wastewater Treatment Plant for recycling system-wide, an assessment of potential costs of implementing any opportunities explored and corresponding cost savings of implementing secondary treatment standards at the Point Loma Wastewater Treatment Plant, and consideration of how such recycling and reclamation opportunities compare to the anticipated cost and availability of imported water. The Study shall be conducted by City staff and private consultant(s) selected and hired by the City.

1.2 Cost of Study. The City will use its best efforts to complete the Study and all the other obligations required by this Agreement for a cumulative amount not to exceed \$2 million. In no event shall the City be obligated to incur more than \$2 million in costs.

1.3 Time for Completion. The Scope of Work shall be negotiated and completed by the Parties by March 31, 2009. The City shall complete the Study within two years after the effective date of the new National Pollutant Discharge Elimination System permit ("Permit") for the Point Loma Wastewater Treatment Plant.

1.4 Coastkeeper/Surfrider Participation. Coastkeeper and Surfrider representatives and one expert may participate in development of the Scope of Work. The City shall compensate the expert for his/her participation in Scope of Work development in an amount not to exceed \$5,000. Coastkeeper and Surfrider may also appoint one expert to work collaboratively with the City in performing and reviewing the Study. The City shall compensate the expert for his/her participation in the Study in an amount not to exceed \$60,000. The costs of experts are included in the \$2 million limit in Section 1.2.

1.5 Quarterly Updates. The City, Coastkeeper, and Surfrider shall meet at least once every three months during performance of the Study to discuss the progress of the study and exchange information relevant to its completion.

1.6 Peer Review. Upon completion of the Study, the City shall submit all completed reports to a peer review panel comprised of three to five experts selected jointly by the City and Coastkeeper or Surfrider. Any costs associated with peer review shall be paid by the City, and are included in the \$2 million limit in Section 1.2.

ARTICLE II – COASTKEEPER AND SURFRIDER RESPONSIBILITIES

2.1 Support of the Waiver. Coastkeeper and Surfrider shall publicly support the tentative decision of the EPA to grant the Waiver and issue the Permit. Such support may be expressed in terms of the City's obligations under this Agreement rather than the merits of the EPA's tentative decision, at Coastkeeper's and Surfrider's discretion. Coastkeeper and Surfrider shall use their best efforts to gain similar commitments from other interested environmental organizations and individuals not to oppose the EPA's tentative decision or the Permit. Coastkeeper and Surfrider shall also not oppose any subsequent approvals of the EPA's tentative decision by any State agencies, except for any modifications made by State agencies that are less stringent than the EPA's proposed Permit conditions. Nothing in this Agreement shall preclude Coastkeeper and

Surfrider from making substantive recommendations to any regulatory agency for strengthening the monitoring provisions of the Permit. Should such recommendation contribute towards any regulatory agency materially and significantly alter the terms of the Permit, the City may exercise its right to suspend or terminate this Agreement pursuant to Section 3.2.

2.2 Other Assistance. Coastkeeper and Surfrider shall attend meetings, communicate with the City, select an expert and provide any other assistance necessary for the City to complete its obligations as set forth in Article I above.

ARTICLE III – SUSPENSION AND TERMINATION

3.1 Third Party Litigation. In the event any person, organization, or other third party initiates litigation, an administrative appeal, or other action challenging the EPA's or a State agency's decision to approve the Waiver, the City may, in its sole discretion, suspend or terminate this Agreement at any time while such litigation, appeal or other action is pending. The City shall provide advance notice of the suspension or termination in writing to Coastkeeper and Surfrider, specifying the period of suspension or the effective date of termination, as applicable.

3.2 Modification of Proposed Permit Conditions. In the event the EPA or a State agency materially and significantly modifies or alters the Permit conditions in the EPA's tentative decision, the City may, in its sole discretion, suspend or terminate this Agreement. The City shall provide advance notice of the suspension or termination in writing to Coastkeeper and Surfrider, specifying the period of suspension or the effective date of termination, as applicable.

3.3 Extension of Time. If this Agreement is suspended pursuant to this Article, the time for completion of the Scope of Work and the Study shall be extended by the length of time of the suspension unless otherwise agreed to in writing by the Parties.

ARTICLE IV – OTHER CONDITIONS

4.1 Effective Date. This Agreement is subject to the approval of the Mayor and City Council. The obligations of the City, Coastkeeper, and Surfrider shall not become effective until such approval is received and this Agreement is fully executed by all Parties.

4.2 Future Obligations. The City is not obligated to implement any projects, studies, operational changes or other recommendations that may arise from completion of the Study or any reports issued thereunder. The City retains sole discretion to implement any or none of the recommendations of the study.

ARTICLE V - MEDIATION

5.1 Mandatory Non-binding Mediation. If a dispute arises out of, or relates to this Agreement, or the breach thereof, and if said dispute cannot be settled through normal contract

negotiations, the Parties agree to settle the dispute in an amicable manner, using any neutral organization agreed upon before having recourse in any court. Mediation is a condition precedent to either Party initiating litigation arising from this Agreement.

5.2 Mediation Costs. The expenses of witnesses for either side shall be paid by the Party producing such witnesses. All other expenses of the mediation, including required traveling and other expenses of the mediator, and the cost of any proofs or expert advice produced at the direct request of the mediator, shall be borne equally by the Parties, unless they agree otherwise.

5.3 Selection of Mediator. A single mediator that is acceptable to both Parties shall be used to mediate the dispute. The mediator will be familiar with the Clean Water Act, if possible.

5.4 Conduct of Mediation Sessions. Mediation hearings will be conducted in an informal manner and discovery will not be allowed. All discussions, statements, or admissions will be confidential and inadmissible in any other proceeding.

5.5 Mediation Results. Any agreements resulting from mediation shall be documented in writing. All mediation results and documentation, by themselves, shall be “non-binding” and inadmissible for any purpose in any legal proceeding, unless such admission is otherwise agreed upon, in writing, by both Parties. Mediators shall not be subject to any subpoena or liability and their actions shall not be subject to discovery.

ARTICLE VI - MISCELLANEOUS

6.1 Notices. In all cases where written notice is required under this Agreement, service shall be deemed sufficient if the notice is deposited in the United States mail, postage paid. Proper notice shall be effective on the date it is mailed, unless provided otherwise in this Agreement. For the purpose of this Agreement, unless otherwise agreed in writing, notices shall be addressed to:

City of San Diego:	Coastkeeper:	Surfrider:
Jim Barrett Public Utilities Director City of San Diego 600 B Street, 13th floor San Diego, CA 92101	Bruce Reznik Executive Director San Diego Coastkeeper 2825 Dewey Road, Suite 200 San Diego CA 92106	Marco A. Gonzalez Coast Law Group LLP 169 Saxony Road, Suite 204 Encinitas, CA 92024

6.2 Non-Assignment. No Party may assign the obligations or benefits under this Agreement, whether by express assignment or otherwise, nor any monies due or to become due hereunder, without the prior written consent of the other Parties.

6.3 Third Party Beneficiaries. This Agreement is solely for the benefit of the City, Coastkeeper, and Surfrider. Any provision of this Agreement that appears to vest any right of

action in third parties is unintended, and any such third party beneficiary is hereby expressly disclaimed.

6.4 Jurisdiction and Venue. The venue for any suit or proceeding concerning this Agreement, the interpretation or application of any of its terms, or any related disputes shall be in the County of San Diego, State of California.

6.5 Successors in Interest. This Agreement and all rights and obligations created by this Agreement shall be in force and effect whether or not any Parties to the Agreement have been succeeded by another entity, and all rights and obligations created by this Agreement shall be vested and binding on any Party's successor in interest.

6.6 Integration. This Agreement and the Exhibits and references incorporated into this Agreement fully express all understandings of the Parties concerning the matters covered in this Agreement. No change, alteration, or modification of the terms or conditions of this Agreement, and no verbal understanding of the Parties, their officers, agents, or employees shall be valid unless made in the form of a written amendment to this Agreement agreed to by both Parties. All prior negotiations and agreements are merged into this Agreement.

6.7 Counterparts. This Agreement may be executed in counterparts, which when taken together shall constitute a single signed original as though all Parties had executed the same page.

6.8 No Waiver. No failure of the City, Coastkeeper, or Surfrider to insist upon the strict performance by the other of any covenant, term or condition of this Agreement, nor any failure to exercise any right or remedy consequent upon a breach of any covenant, term, or condition of this Agreement, shall constitute a waiver of any such breach of such covenant, term or condition. No waiver of any breach shall affect or alter this Agreement, and each and every covenant, condition, and term hereof shall continue in full force and effect to any existing or subsequent breach.

6.9 Municipal Powers. Nothing contained in this Agreement shall be construed as a limitation upon the powers of the City as a chartered city of the State of California.

6.10 Drafting Ambiguities. The Parties agree that they are aware that they have the right to be advised by counsel with respect to the negotiations, terms and conditions of this Agreement, and the decision of whether or not to seek advice of counsel with respect to this Agreement is a decision which is the sole responsibility of each Party. This Agreement shall not be construed in favor of or against either Party by reason of the extent to which each Party participated in the drafting of the Agreement.

6.11 Conflicts Between Terms. If an apparent conflict or inconsistency exists between the main body of this Agreement and the Exhibits, the main body of this Agreement shall control. If a conflict exists between an applicable federal, state, or local law, rule, regulation, order, or code and this agreement, the law, rule, regulation, order, or code shall control. Varying degrees of stringency among the main body of this agreement, the Exhibits, and laws, rules, regulations, orders, or codes are not deemed conflicts, and the most stringent requirement shall control. Each

Party shall notify the other immediately upon the identification of any apparent conflict or inconsistency concerning this Agreement.

6.12 Exhibits Incorporated. All Exhibits referenced herein are incorporated into this Agreement by this reference.

6.13 Signing Authority. The representative for each Party signing on behalf of a corporation, partnership, joint venture, organization or governmental agency hereby declares that authority has been obtained to sign on behalf of the entity. If any representative signatory hereto lacked such authority at the time of execution of this Agreement, this Agreement is voidable at the discretion of the adversely affected Party.

[remainder of page intentionally blank]

IN WITNESS WHEREOF, this Agreement is executed by the City of San Diego, acting by and through its Mayor or his designee, pursuant to City Council Resolution No. R-304617 authorizing such execution, by San Diego Coastkeeper, and by the San Diego Chapter of Surfrider Foundation.

SAN DIEGO COASTKEEPER

CITY OF SAN DIEGO

By: 
Bruce Reznik
Executive Director

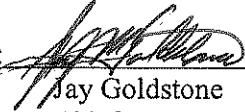
By: 
Jay Goldstone
Chief Operating Officer

Date: January 30, 2009

Date: 2/17/09

SURFRIDER FOUNDATION
SAN DIEGO CHAPTER

I HEREBY APPROVE the form and legality of the foregoing agreement this 18 day of February, 2009.

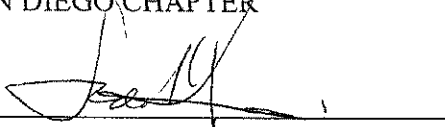
By: 
Scott Harrison
Executive Committee Chairman

JAN I. GOLDSMITH, City Attorney

Date: 3 FEB 2009

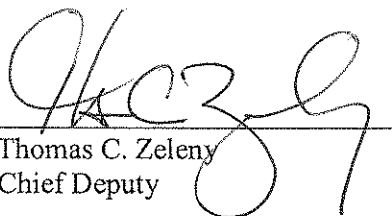
By: 
Thomas C. Zeleny
Chief Deputy

Approved as to form:

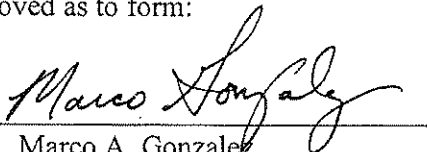
By: 
Marco A. Gonzalez
Coast Law Group LLP
Attorney for Coastkeeper and Surfrider

This page intentionally left blank.

APPENDIX B: POINT LOMA
WASTEWATER TREATMENT PLANT CONCLUSIONS



This page intentionally left blank.

APPENDIX B

POINT LOMA WASTEWATER TREATMENT PLANT CONCLUSIONS

As the San Diego region continues to pursue local sustainable water supplies through the development of non-potable recycled water and indirect potable reuse opportunities, the Point Loma Plant will ultimately become a smaller wastewater treatment facility within the Metro System. Potential new water reuse facilities will use a portion of the flows that currently feed the Point Loma Plant; thus, reducing the quantity of flows received and treated at the Point Loma Plant. This section discusses the changes that may occur at the Point Loma Plant as a result of future increased reuse within the Metro System and conversion to secondary treatment.

B.1 Point Loma Plant

As Water Reclamation Plants and Advanced Water Purification Facilities are planned and constructed within the Metro System, wastewater flows will be diverted to these upstream locations and the Point Loma Plant will be required to treat smaller quantities of wastewater. However, it is expected that the concentration of the influent will change due to the added discharges from these potential Water Reclamation Plants and Advanced Water Purification Facilities. Figure B-1 lists the possible components that may characterize the influent stream in the case that the Point Loma Plant receives discharges from additional future water reuse facilities.

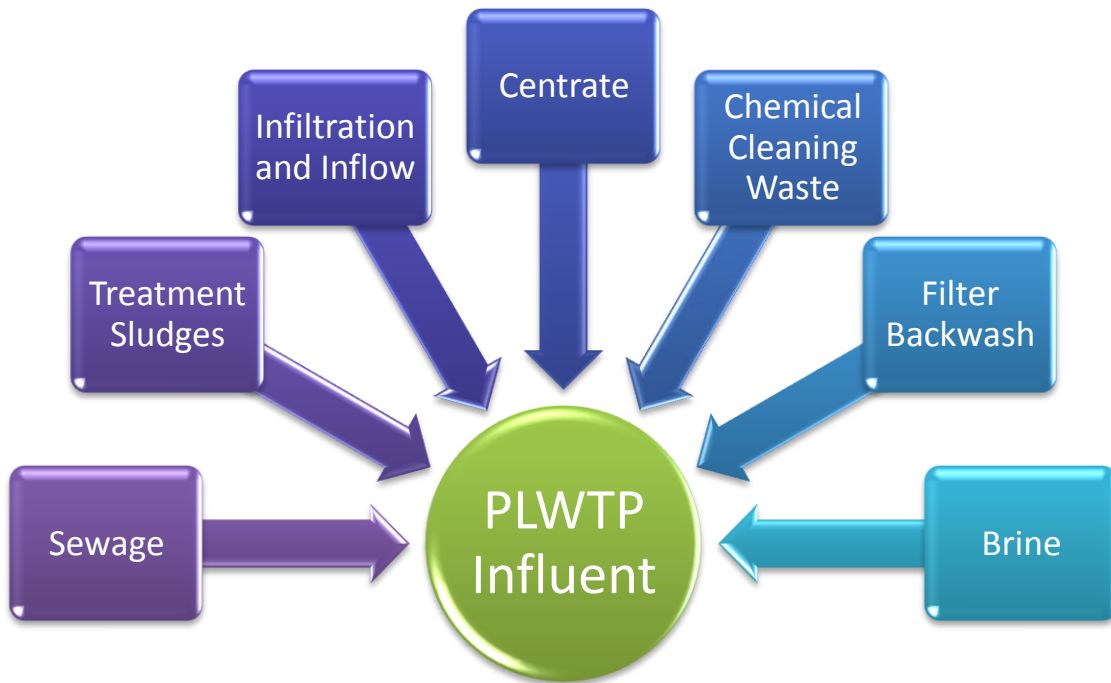

Figure B-1. Make-up of Point Loma Plant Influent

Table B-1 provides a detailed breakdown of the allocation of the 2050 Metro System 10-year annual average daily flow (AADF) and peak wet weather flow (PWWF) after reuse alternatives have been implemented. Figure B-2 presents the 2050 10-year AADF breakdown in pie chart format. When sizing the Point Loma Plant it was assumed that non-potable recycled water would not be used during wet weather which leaves approximately 143 mgd of flow reaching the Point Loma Plant. At this size, a biological aerated filter (BAF)

was assumed for the secondary process. This system, when sized at 143 mgd AADF, can only treat up to 243 mgd during storm events (77 mgd less than the anticipated peak flow reaching the plant). Blending of secondary and chemically-enhanced primary treatment (CEPT) effluents will be required during PWWF. A mass balance evaluation of the proposed blending scenario (77 mgd primary effluent blended with 243 mgd secondary effluent) indicates that it will meet secondary permit requirements for total suspended solids (TSS) and biochemical oxygen demand (BOD). A storage capacity of 28 million gallons (MG) is required to equalize flow during peak wet weather events so that the Point Loma Plant influent does not exceed 320 mgd. This 28 MG of storage upstream of the Point Loma Plant is 7 MG less than the storage proposed in the September 2011 Draft Wastewater Master Plan. Note that the impact of the diversions on the Point Loma Plant influent will be relatively similar between the themes since the amount of source water diversion does not change, only the location where the additional treatment is provided changes.

Table B-1. Allocation of 2050 Metro System 10-Year AADF and PWWF

	2050 10-Year AADF	2050 10-Year PWWF	Remark
Metro System	278 mgd	647 mgd	Source: September 2011 Draft Metropolitan Wastewater Plan
South Bay Diversion (SV8)	47 mgd	133 mgd	An attenuation factor of 0.9 was applied to the PWWF at the SV8 diversion when subtracting it from the Point Loma Plant influent
GAPS	18 mgd	18 mgd	An attenuation factor of 0.9 was applied to the PWWF at the SV8 diversion when subtracting it from the Point Loma Plant influent
San Vicente IPR	68 mgd	68 mgd	Planned IPR to the San Vicente Reservoir
El Monte IPR	5 mgd	5 mgd	From the El Monte Project or equivalent project
South Bay Return Solids	3 mgd	3 mgd	Approximate solids return flow
Storage	N/A	28 MG	28 MG of storage can equalize 441 mgd so that the influent to the Point Loma Plant is 320 mgd
Point Loma Plant	143 mgd	320 mgd	

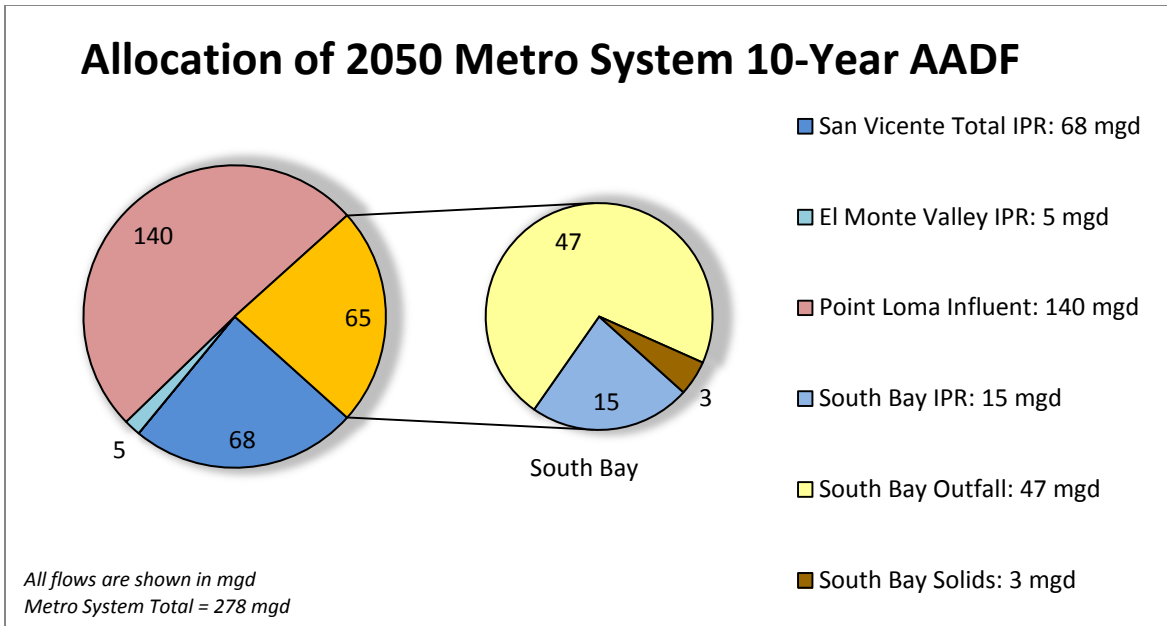

Figure B-2. Allocation of 2050 Metro System Annual Average Daily Flows with a 10-year Wet Weather Event

These flows were used to size the Point Loma and South Bay Plants during a critical wet weather event. The 3 mgd of South Bay Solids may be returned to the Point Loma Plant for a total influent of 143 mgd.

The major technologies and processes proposed to treat the remaining flows at the Point Loma Plant to secondary treatment standards are shown on Figure B-3. It is anticipated that these facilities will be capable of adequately treating the incoming wastewater to secondary treatment standards, but it is strongly suggested that a pilot test be conducted prior to design to confirm treatment process performance under local conditions.

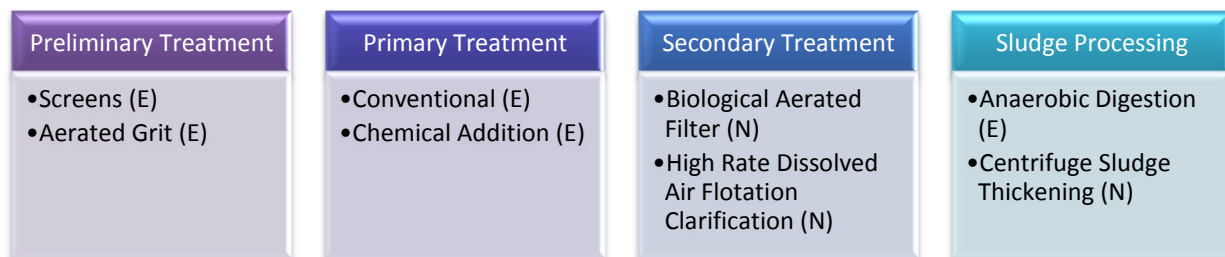

Figure B-3. Proposed Major Processes for a 143 mgd Point Loma Plant

(E = Existing Process; N = New Process)

B.1.1 Chemically Enhanced Primary Treatment (CEPT) Considerations

The Point Loma Plant currently processes incoming wastewater through a CEPT process prior to discharge. CEPT is a physical process that enhances the removal of total suspended solids (TSS) with the aid of a coagulant and flocculent. Organics, or biochemical oxygen demand (BOD), removal is also enhanced by virtue of removing organics in particulate forms. Removal efficiencies for TSS increase from 65 percent to about 75 to 85 percent; consequently BOD removal jumps from 35 percent to about 50 to 60 percent when

compared to conventional primary treatment. Over the years, City operations staff has managed to improve the process to a point where the TSS removal efficiency is as high as 90 percent and the BOD is at 60 percent. The Point Loma Plant effluent has been recorded to have a TSS concentration below the secondary TSS limit of 30 mg/L on occasion.

The low cost of CEPT and the proven minimal impact of BOD on the receiving waters and indigenous organisms from its discharged flows has raised the idea of maintaining CEPT at the Point Loma Plant even after the proposed upgrades. If it were allowed, the Study Team estimated the amount of diversion required upstream so that the projected TSS mass emission rate (MER) for a smaller CEPT plant would be equivalent to the MER of a secondary plant at the current Point Loma Plant permitted capacity of 240 mgd. Table B-2 provides a preliminary summary of the MERs at the Point Loma Plant for various flow scenarios. Figure B-4 provides a graphical representation of the historical TSS MER and the projected MER. These MERs were calculated based on achieving an effluent quality similar to what has been achieved in the last few years. It is assumed that process improvements will be incorporated to achieve the effluent quality presented. Included in the summary are TSS MERs associated with a Point Loma Plant that produces 143 mgd of effluent.

Treatment	Capacity (mgd)	Percent TSS Removal (%)	Point Loma Plant Effluent TSS		
			(mg/L)	(lb/d)	(mt/yr)
Secondary	240	90	30	60,048	9,942
	200	90	30	50,040	8,285
	143	90	30	35,779	5,924
	100	90	30	25,020	4,142
CEPT	240	87	40	80,064	13,256
	240	88	35	70,056	11,599
	200	87	40	66,720	11,046
	200	88	35	58,380	9,666
	143	87	40	47,705	7,898
	143	88	35	41,742	6,911
	100	87	40	33,360	5,523
	100	88	35	29,190	4,833

Notes: 240 mgd is the permitted capacity of the Point Loma Plant. Secondary effluent limits include a 30/30 mg/L TSS/BOD limit. Calculations based on an assumed effluent quality. Influent TSS concentration assumed to be 297 mg/L.

Post process solids (e.g., sludge, filter backwash and centrate solids) returned to the Point Loma Plant increases the concentration of the TSS in the influent. The values in Table B-2 simply assume that the Point Loma Plant produces the noted effluent quality regardless of the influent quality. For conditions A, B, and C shown in Table B-4, a CEPT plant must remove more than 90 percent of the incoming TSS to meet the current permitted TSS MER of 13,598 metric tons per year. There are several approaches to increasing the TSS removal efficiency, including 1) decreasing the surface overflow rate (SOR); 2) increasing chemical addition; and/or 3) install finer screens. It is recommended these approaches be pilot tested to confirm removal efficiencies under local conditions.

The most impactful approach to achieving the needed performance at the Point Loma Plant would be to treat the solids where they are produced and not reintroduce sludge into the Metro System. This approach

supports the construction of a solids processing facility in the South Bay as recommended in the September 2011 Draft Wastewater Master Plan. Solids produced at the Harbor Drive or Mission Gorge Facility could be sent to the Point Loma Plant or piped directly to the MBC for subsequent treatment. A follow-up evaluation should be performed to determine the most cost effective approach. It should be noted that the costs associated with solids facilities are assumed to be covered by wastewater funds and would not impact the costs presented in this Study.

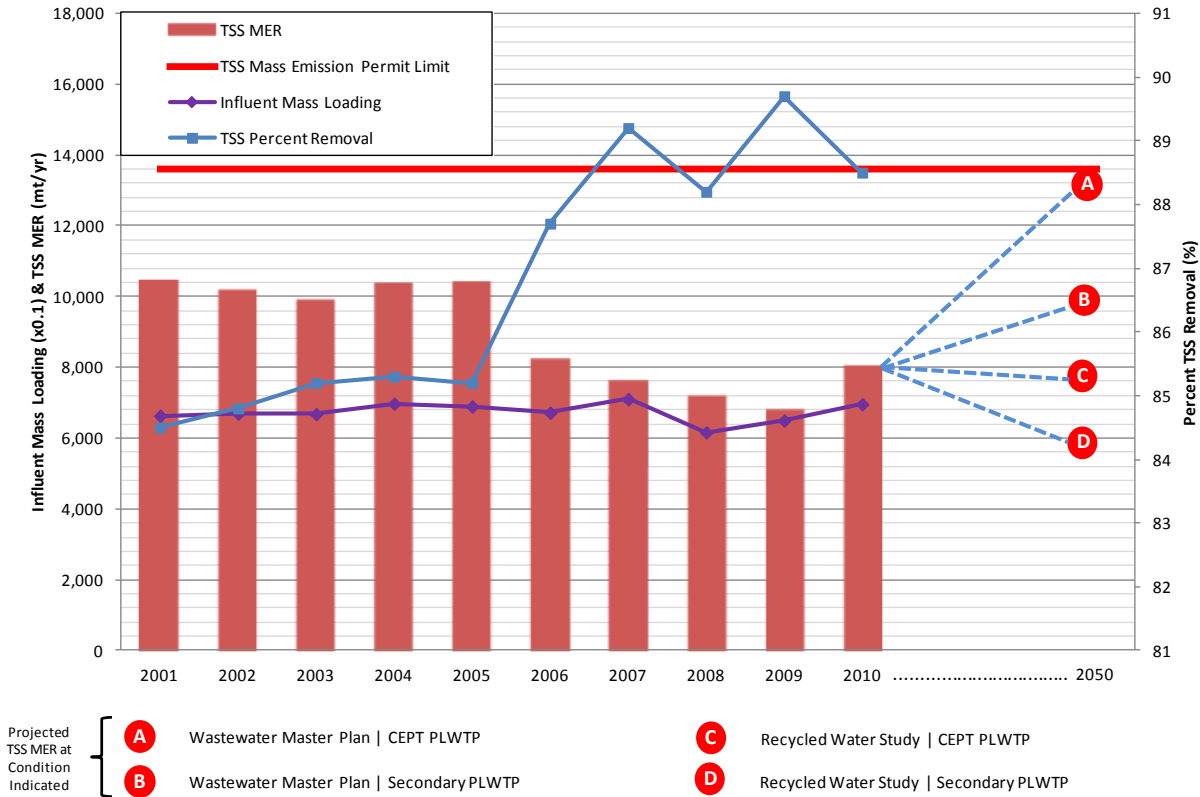

Figure B-4. Historical and Projected Point Loma Plant TSS MER (MER projections based on assumed effluent quality)
 PLWTP = Point Loma Wastewater Treatment Plant
 CEPT = Chemically-Enhanced Primary Treatment

Future TSS MER was also projected assuming the primaries would remove TSS at the same level as they have in the past few years. This calculation accounts for the increased solids concentration in the Point Loma Plant influent resulting from the return of wastes (sludge, centrate and filter backwash) from upstream facilities and estimates the effluent quality based on present day performance. It is important to note that during a secondary process, solids are actually generated at a rate of approximately 1 pound of TSS per pound of BOD removed. This essentially increases the amount of solids that must be removed from the system beyond the amount originally produced by the users of the Metro System. The projected MERs from this evaluation are shown on Figure B-5. Table B-3 provides the historical Point Loma Plant data regarding performance related to the removal of TSS and BOD. Table B-4 shows an accounting of the solids in the Point Loma Plant influent for the various conditions shown on Figure B-5, differentiating solids generated originally by Metro System users and those that are returned as sludge, filter backwash and biosolids processing wastes.



Table B-3. Recorded Values from the Point Loma Plant Annual Reports

Year	Flow (mgd)	TSS							BOD						
		Influent			Effluent			Percent Removal	Influent			Effluent			Percent Removal
		(mt/yr)	(lbs/day)	(mg/L)	(mt/yr)	(lbs/day)	(mg/L)		(mt/yr)	(lbs/day)	(mg/L)	(mt/yr)	(lbs/day)	(mg/L)	
2001	174.8	66,333	400,655	275	10,392	61,931	43	84.5	61,199	369,643	254	22,717	136,700	94	63.0
2002	168.9	66,953	404,400	287	10,114	61,493	44	84.8	61,937	374,104	266	21,763	132,086	94	64.7
2003	169.8	66,786	403,389	285	9,847	59,459	42	85.2	63,482	383,437	271	24,618	148,461	105	61.3
2004	173.9	69,753	421,312	291	10,325	62,028	43	85.3	61,189	369,585	255	24,252	146,787	101	60.3
2005	183.2	68,968	416,573	274	10,371	61,768	41	85.2	63,232	381,927	252	26,561	158,793	105	58.4
2006	169.9	67,201	405,899	287	8,211	49,806	35	87.7	63,635	384,359	271	23,929	144,197	102	62.5
2007	161.4	71,016	428,942	319	7,577	45,822	34	89.2	67,669	408,723	304	21,172	128,471	95	68.5
2008	161.8	61,645	372,338	277	7,169	43,802	32	88.2	62,211	375,757	280	21,507	129,324	96	65.6
2009	153.3	64,980	392,482	308	6,774	40,214	32	89.7	61,544	371,727	292	21,168	128,304	100	65.5
2010	156.7	69,578	420,257	323	8,006	48,585	37	88.5	62,006	374,517	287	22,503	135,410	104	63.8

Source: 2001 - 2010 Annual Reports and Summary Point Loma Wastewater Treatment Plant & Ocean Outfall



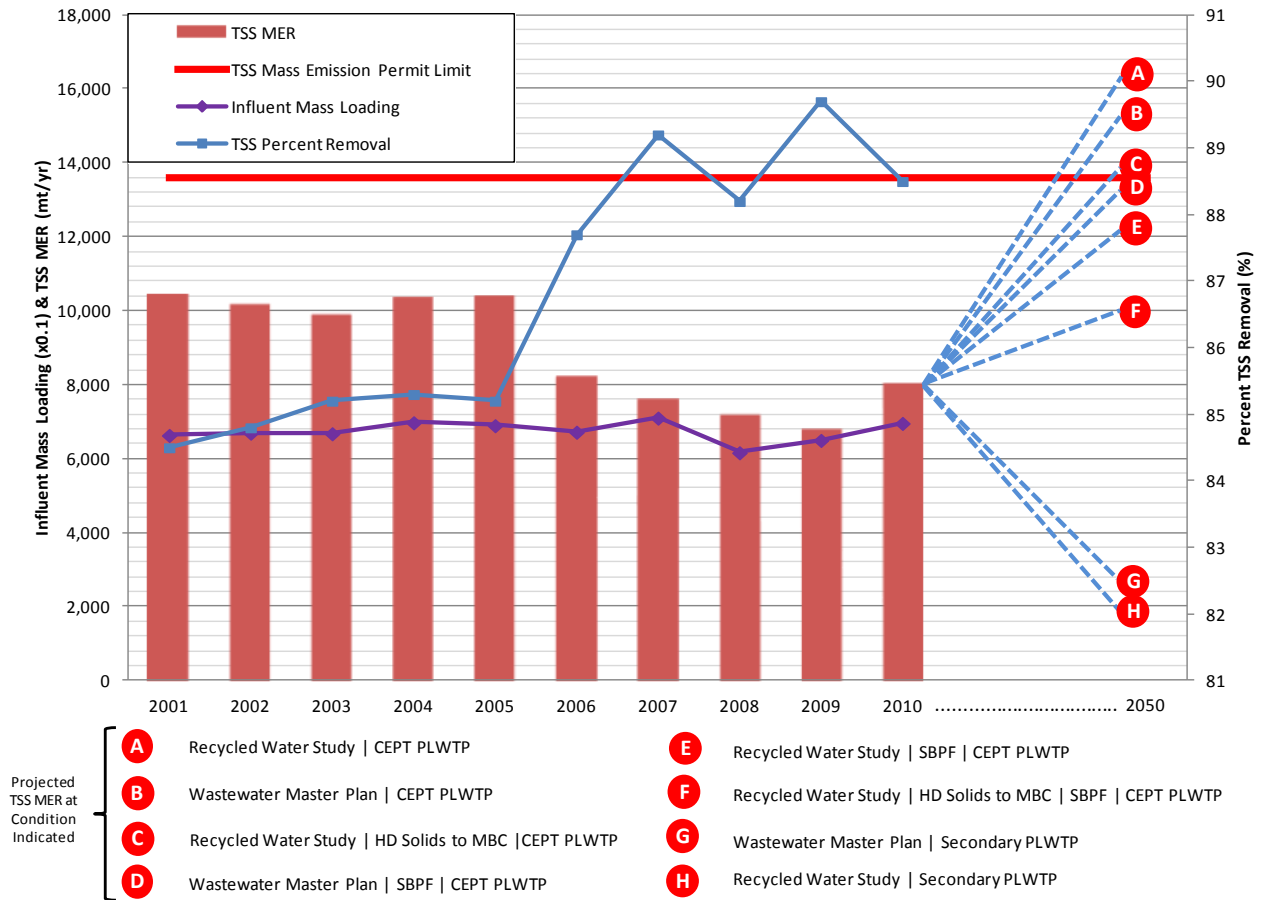

Figure B-5. Historical and Projected Point Loma Plant TSS MER (MER projections based on assumed removal efficiency)

Note: Harbor Drive and South Bay solids returned to Point Loma unless indicated.

PLWTP = Point Loma Wastewater Treatment Plant

CEPT = Chemically-Enhanced Primary Treatment

HD = Harbor Drive

MBC = Metropolitan Biosolids Center

SBPF = Southern Biosolids Processing Facility (Solids are treated at the South Bay and are not returned to Point Loma)



Table B-4. Point Loma Plant Influent Solids (Metro System-Generated Solids Vs. Return Solids)			
Condition (see Figure B-5)	Metro System Solids (lb/day)	Return Solids (lb/day)	Total Point Loma Plant Influent Solids (lb/day)
A	318,221	377,859	696,080
B	545,311	123,180	668,491
C	318,221	260,761	578,982
D	545,311	23,957	569,268
E	318,221	203,806	522,027
F	318,221	86,708	404,929
G	545,311	123,180	668,491
H	318,221	377,859	696,080

Note: Metro System-Generated Solids include solids discharged by Metro System users in the form of raw wastewater. Return solids include sludge, filter backwash, and centrate solids.

The evaluation indicates the importance of providing solids processing at South Bay if the Point Loma Plant is to remain a CEPT plant. It also indicates that the return of sludge produced at a Harbor Drive Plant or a Mission Gorge Plant to the sewer does not impact meeting the current TSS MER limit (shown on Figure B-5). It should be noted that the actual TSS MER limit will likely be lower, but has not been defined by regulators yet.

The Study approach includes a base assumption that secondary upgrades would be required at the Point Loma Plant; however, it does not preclude the assumption that an aggressive reuse plan, supported by regulators and the environmental community, could allow deferring and possibly eliminating the need for secondary upgrades. Allowing CEPT to be maintained after the reuse system expansion would provide significant cost savings to the region's ratepayers.

APPENDIX C: SUMMARY OF REGULATIONS THAT AFFECT WATER, WASTEWATER AND RECYCLED WATER



This page intentionally left blank.

APPENDIX C

SUMMARY OF REGULATIONS THAT AFFECT WATER, WASTEWATER AND RECYCLED WATER

Water, wastewater and recycled water systems are governed by rules and regulations. The following sections summarize the wastewater regulations (pertinent to the Point Loma Plant and ocean water discharge quality) and the water reuse regulations. The water reuse regulation summary includes the regulatory assumptions used to develop the indirect potable reuse alternatives.

C.1 Wastewater Regulations

A majority of the San Diego region’s wastewater is treated and then discharged to the Pacific Ocean. The discharge of treated wastewater effluent via ocean outfalls is governed by federal and state regulatory requirements, as discussed below.

C.1.1 National Pollutant Discharge Elimination System Permit

All point-source discharges to surface waters of the United States are regulated via the National Pollutant Discharge Elimination System (NPDES) Permit Program. Introduced in 1972, the NPDES permit program is managed by the Environmental Protection Agency in partnership with State Water Resources Control Board (State Water Boards) and Regional Water Quality Control Boards (Regional Water Boards). The NPDES process requires dischargers to apply for and obtain permits prior to effluent discharge, and also establishes technology-based requirements for municipal agencies. Treatment involving several physical, chemical and biological processes to remove solids and organics from incoming wastewater streams is typically required prior to ocean disposal. Concentration limits are typically set for certain parameters at 30-day and 7-day running averages and/or instantaneous events. Limits are also imposed on the total weight of materials (also known as mass emission rates) discharged which are based on the concentration limits. Limits prescribed for secondary treated effluents for total suspended solids and total biochemical oxygen demands are presented in Table C-1. In addition, at least 85 percent of the total suspended solids in the untreated wastewater must be removed, and the pH cannot fall below 6 nor exceed 9 at any time.

Table C-1. Secondary Effluent Requirements			
Parameter	Concentration in mg/L		
	30-day Rolling Average	7-day Rolling Average	Instantaneous
Total Suspended Solids	30	45	60
Total Biochemical Oxygen Demand	30	45	60



C.1.2 California Ocean Plan

The State Water Board first adopted the Ocean Plan in 1972 which set water quality standards to protect the beneficial uses of all ocean waters of California and prescribed programs to implement these standards. The State Water Board maintains and updates the California Ocean Plan on a three year cycle, the latest cycle being 2011 to 2013. The State Water Board has the authority to administer and enforce the provisions of the Ocean Plan, including effluent limitations established under the Federal Clean Water Act. The provisions of the plan may include monitoring and reporting requirements, and pollution minimization programs aimed at point-source dischargers. The water quality objectives and effluent limitations apply to several classes of pollutants, including heavy metals, radioactive substances, carcinogens, volatile and semi-volatile organic compounds, pesticides, suspended solids, pH, oil and grease, and temperature. Details on the water quality objectives and effluent limitations may be reviewed by downloading the current Ocean Plan, available at the State Water Board website.

C.1.3 Blending of Treated Effluents

In 2003, the Environmental Protection Agency proposed a policy allowing ocean disposal of blended wastewater during high flow wet weather (rainstorm) events. Blended wastewater included two primary components: flows that were treated through all the treatment processes, and a stream that bypassed certain treatment processes that were not sized for these infrequent peak loads. This approach also allows sensitive biological processes to be protected from upset conditions. The Environmental Protection Agency policy on blending requires the following (*EPA's Proposed Policy on Wastewater Blending: Background and Issues*, Congressional research Service, February 2005):

- The final blended discharge must meet effluent limitations based on the secondary treatment regulation, including applicable percentage removal requirements, or any more stringent limits necessary to attain water quality standards.
- The facility's permit application must specify the treatment scenario to be used for peak flow management.
- All flow must receive at least the equivalent of primary clarification (typically 65 percent removal of the total suspended solids and 35 percent removal of the total biochemical oxygen demand measured in the incoming wastewater).
- Peak flow treatment should be operated as designed and only be used when flows exceed the capacity of storage units and biological treatment units.
- The facility's discharge permit must require sufficient monitoring to ensure compliance with applicable Clean Water Act requirements.
- The permit also must require that the permittee's collection system be properly operated and maintained.

C.2 Ocean Pollution Reduction Act (OPRA)

In addition to a critical water supply need, wastewater management also drives the need to maximize local water recycling. Since 1963 the City has treated its wastewater at the Point Loma Plant, which provides advanced primary treatment before disposal in an ocean outfall. In 1972, the federal Clean Water Act (CWA) was adopted which requires that wastewater plants provide a minimum of secondary treatment. Section 301(h) of the CWA allowed facilities that discharge to certain marine waters to apply for a waiver from secondary treatment standards by 1982. The City originally applied for the waiver, but then withdrew it. In 1987, the U.S. Environmental Protection Agency (EPA) and environmental groups sued the City for not meeting the provisions of the CWA. The Ocean Pollution Reduction Act (OPRA) was passed in 1994 to allow San Diego to reapply for the Section 301(h) waiver. The lawsuit was resolved later that year when the waiver was granted, saving the City an estimated \$3 billion in avoided capital costs for additional facilities.

As part of the Section 301(h) application, the City committed to implementing a water reclamation program that would create a system capacity to treat 45 mgd by 2010. The City has fulfilled the treatment capacity requirement with the completion of the 30 mgd North City Plant in 1997 and the 15 mgd South Bay Plant in 2002. A 1995 federal court order further required the City to construct an “optimized recycled water distribution system” in conjunction with building the North City Plant. The majority of the distribution facilities that comprise the optimized system were installed between 1995 and 1998 to enable delivery of recycled water upon completion of the reclamation plant.

Currently, approximately 11 mgd of recycled water is beneficially reused. Through the retrofit program for existing water customers and by requiring developers in the North City Plant service area to construct recycled water conveyance systems to new developments, the City has diligently pursued the fulfillment of the water reuse goals.

C.3 Non-potable Recycled Water Regulations

Non-potable recycled water (also referred to as *Reclaimed Water* in the United States or *Title 22 Water* in California) is a broad term that encompasses several beneficial uses of treated wastewater. The two state agencies that have primary responsibility for regulating the implementation of non-potable recycled water projects are the California Department of Public Health (CDPH) and the Regional Water Boards. Chapter 3 of the California Code of Regulations Title 22, Division 4, outlines criteria for non-potable water recycling. This document is commonly abbreviated as Title 22 in the industry, and contains regulations that govern the sources, production, intended use and quality of recycled water.

C.3.1 State Water Board Recycled Water Policy

In 2009, the State Water Board adopted a recycled water policy aimed at increasing recycled water usage, minimizing carbon footprint, and promoting sustainable management of surface and groundwater resources. The policy lists the following primary goals for statewide implementation:

- Increase recycled water usage over 2002 levels by one million acre foot per year (AFY) by 2020 and by at least two million AFY by 2030
- Increase stormwater reuse by at least half a million AFY by 2020 and at least one million AFY by 2030
- Increase water conservation in industrial and urban uses by 20 percent by 2020
- Substitute as much recycled water for potable water as possible by 2030

Although increased conservation and use of stormwater is planned, the thrust of the policy is to increase the use of recycled water from municipal sources in a manner that complies with Title 22 and all other applicable state and federal water quality laws and regulations. The policy describes criteria intended to streamline and generate consistency in permitting recycled water projects. Topics addressed by the policy include:

- Salt and nutrient management plans for groundwater basins and watersheds
- Streamlined permitting for landscape irrigation projects that use recycled water
- Recycled water groundwater recharge projects
- Anti-degradation (a State water quality standard requires that existing quality of the receiving waters be maintained unless the degradation is necessary to accommodate important social and economic development in the service area)
- Contaminants of emerging concern (chemicals such as pharmaceuticals, endocrine-disrupting compounds such as hormones, and other environmentally persistent chemicals that enter the wastewater system through human use)
- Incentives for using recycled water

C.3.2 Allowable Uses for Recycled Water

Non-potable recycled water applications are dictated by Title 22 and vary depending on the level of treatment provided, as summarized in Table C-2. Limited applications are allowed at secondary treatment levels. Most agencies in California operate water reclamation plants meeting disinfected tertiary standards (which add filtration and disinfection process after secondary treatment). Disinfected tertiary treatment plants allow serving much broader uses. The City's, along with Padre Dam's and the Otay Water District's, plants include disinfected tertiary treatment, which allows them to serve the broadest application of non-potable recycled water uses.

Table C-2. Allowable Non-potable Uses based on Title 22 Treatment Level

Type of Recycled Water Use	Recycled Water Treatment Level		
	Disinfected Tertiary	Disinfected Secondary	Non-disinfected Secondary
Urban Uses and Landscape Irrigation			
Fire Protection	✓		
Toilet and Urinal Flushing	✓		
Irrigation of Parks, Schoolyards, Residential Landscaping	✓		
Irrigation of Cemeteries, Highway Landscaping	✓	✓	
Irrigation of Nurseries	✓	✓	
Landscape Impoundment	✓	✓*	
Agricultural Irrigation			
Pasture for Milk Producing Animals	✓	✓	
Fodder and Fiber Crops	✓	✓	✓
Orchards (no contact between fruit and recycled water)	✓	✓	✓
Vineyards (no contact between fruit and recycled water)	✓	✓	✓
Non-Food Bearing Trees	✓	✓	✓
Food Crops Eaten After Processing	✓	✓	
Food Crops Eaten Raw	✓		
Structural Fire Fighting	✓		
Commercial Car Washes	✓		
Commercial Laundries	✓		
Artificial Snow Making	✓		
Soil Compaction, Concrete Mixing	✓	✓	
Environmental and Other Uses			
Recreational Ponds with Body Contact (Swimming)	✓		
Wildlife Habitat/Wetland	✓	✓	
Aquaculture	✓	✓*	
Groundwater Recharge			
Seawater Intrusion Barrier	✓*		
Replenishment of Potable Aquifers	✓*		

* Restrictions may apply

SOURCE: Water Recycling 2030, California's Recycled Water Task Force, June 2003.



C.4 Indirect Potable Reuse Regulations

Indirect potable reuse is regulated by the CDPH and the Regional Water Board through the issuance of NPDES permits and Waste Discharge Requirements. Although indirect potable reuse groundwater recharge projects exist in California, uniform regulations have not been adopted. Implementation of existing groundwater recharge projects were based on individual permits and general conformance to CDPH's August 2008 draft regulations specific to the treatment, monitoring and recharge of recycled water for augmenting groundwater basins. General requirements for indirect potable projects include:

- Developing an industrial pre-treatment and pollutant source control program.
- Complying with effluent limits established in the Regional Water Board permit for the reuse project.
- Developing a CDPH-approved plan that provides an alternative source of domestic water supply or a CDPH-approved treatment mechanism in the event that the reuse project causes the drinking water source to become unusable.
- Conducting a public hearing for reuse projects, with specific requirements for public notification via various methods.
- Preparing a CDPH-approved operations plan.
- Sampling the water in the target aquifer before starting the recharge project.

C.4.1 Indirect Potable Reuse Legislation

Senate Bill 918 (SB 918) was approved by the Governor of California and filed with the Secretary of State on September 30, 2010. Among other amendments to the Water Code, SB 918 requires the CDPH to:

- **Uniform Groundwater Recharge Criteria**—adopt uniform water recycling criteria for indirect potable reuse projects using groundwater recharge by December 31, 2013;
- **Uniform Reservoir Augmentation Criteria**—develop and adopt uniform water recycling criteria for indirect potable water projects using surface water augmentation by December 31, 2016;
- **Uniform Direct Potable Reuse Criteria**—investigate the feasibility of developing uniform water recycling criteria for direct potable reuse and provide a final report on the investigation to the Legislature by December 31, 2016.

C.4.2 Regulatory Assumptions for Developing Projects in this Study

Indirect potable reuse projects described in this study were developed using the current CDPH draft regulations for groundwater recharge, anticipated regulations for reservoir augmentation, the City's recent coordination with CDPH on the Water Purification Demonstration Project, and recent regulatory trends based on other indirect potable reuse projects (such as the Orange County Water District's Groundwater Replenishment System). It is important to note that indirect potable reuse regulations are dynamic, and even evolved through the course of this Study. The following sections summarize the anticipated regulatory constraints used to develop indirect potable reuse concepts in this Study. While they will likely continue to evolve, the following categories provide an appropriate range of considerations for developing reuse alternatives and are further discussed in this section.

- Hydraulic retention time
- Short circuiting (for reservoir augmentation projects)
- Recycled water contribution rate
- Nutrients and eutrophication

C.4.2.1 Hydraulic Retention Time

Indirect potable reuse projects include advanced purification treatment and the reintroduction and blending of the water into the natural environment – through a groundwater basin or reservoir. Hydraulic retention time is the time it takes for this water to move through a groundwater basin or reservoir before extraction. The CDPH draft regulations requires advanced treated water to be stored in a groundwater basin for a minimum period of time to blend with the untreated water and undergo a measure of natural treatment. Similar criteria may be incorporated into pending draft regulations for reservoir augmentation, possibly in conjunction with other criteria related to short circuiting. Initially, the alternatives being developed in this Study assumed that a one-year hydraulic retention time would be required in the early project phases, with a reduction to six months once the operation was proven. Based on recent discussions between the City and CDPH, it is generally believed that hydraulic retention time criteria for reservoir augmentation may be tailored specifically to the application, as opposed to developing universal criteria that could be applied to a broader range of projects. These project-specific ranges are not anticipated to be longer than 12 months. It is also anticipated that the required hydraulic retention time may reduce with time as more reservoir augmentation projects are implemented and demonstrate successful operation over longer periods.

C.4.2.2 Reservoir Short Circuiting

Short circuiting is related to hydraulic retention time and is a consideration primarily for indirect potable reservoir augmentation projects. Short circuiting can occur when the reservoir dynamics allow a portion of the advanced purified water from the indirect reuse project to reach the extraction point quicker than desired. This dynamic occurrence is more prevalent in the wintertime when temperature changes can allow rapid mixing of the reservoirs. The City's Water Purification Demonstration Project includes evaluating short circuiting further.

C.4.2.3 Recycled Water Contribution Rate

Another consideration is the recycled water contribution rate, which is the ratio of recycled water to the water it blends with—either natural groundwater or imported untreated water. Recycled water contribution rate considerations include its measurement (monthly, annual, etc.) from the regulatory perspective since the water delivered through reservoirs and groundwater basins changes seasonally, and public perception related to what percentage of the water supply should include advanced purified water from indirect potable reuse. Actual recycled water contribution rates will be determined as part of the Water Purification Demonstration Project. For the purposes of developing the reuse alternatives in this Study, an initial target of 50 percent was used. In other words, the recycled water must be blended 50/50 with another source for recharge (such as groundwater, untreated water or stormwater). The Study also assumed that recycled water contribution rate limits would be relaxed once the indirect reuse project is operational and proven successful, similar to other California projects.

C.4.2.4 Control of Nutrients

Increased nutrient concentrations in natural systems, primarily nitrogen and phosphorus, directly impact the degree of eutrophication. When lakes and reservoirs become eutrophic, they are often characterized by reduced water clarity, periodic algae blooms, wide swings in dissolved oxygen concentrations, and other generally unfavorable conditions. The results of the Water Purification Demonstration Project and the final permit conditions will establish the treatment processes needed to achieve nutrient control.

C.4.2.5 Chemicals of Emerging Concern

Recent trends in recycled water use applications have focused on chemicals of emerging concern (CECs). Such chemicals include pharmaceuticals, endocrine-disrupting compounds such as hormones, and other environmentally persistent chemicals that enter the wastewater system through human use. These constituents are not currently regulated in the potable water supply or in wastewater. Studies indicate that conventional wastewater treatment partially removes CECs, but advanced treatment such as reverse osmosis followed by advanced oxidation may be able to reduce such chemicals to very low levels.

The State Water Board recently released a fact sheet that reported the findings of a Blue Ribbon Advisory Panel. The draft report released by the panel provided guidelines for establishing a baseline monitoring program for indirect potable reuse projects. Initial, or Phase I, monitoring of priority CECs on a quarterly basis was recommended for a minimum of two years during project startup. CECs that consistently meet certain threshold conditions during Phase I may be deleted from the priority list. During Phase II, monitoring frequency is reduced to twice per year for three years, provided that CEC concentrations are below established thresholds. Phase III provides for increased monitoring, source identification studies, toxicological studies, and the potential for plant modifications to further reduce CEC concentrations.

The State Water Board Report also stated that the public can also play a role in reducing CEC's in the water supply by properly disposing of unused pharmaceuticals, preventing the discharge of cleaning products to the sewer or storm drain, and using personal care products sparingly. A public information campaign can help educate the public and achieve a noticeable reduction.

Finally, the report concludes that “no adverse human health impacts have been documented from exposure to the extremely low concentrations of pharmaceuticals or personal care products found in water supplies.” Thus, while research shows that these CECs pose no danger to human health, the City plans on providing treatment facilities that meet or exceed State and Federal standards to protect public health.

C.5 Direct Potable Reuse Regulations

Direct potable reuse refers to the advance purification of recycled water to a purity level acceptable to allow it to be directly connected to the potable water system (or connected just upstream of a potable water treatment plant if an additional level of treatment is desired). In contrast to indirect potable reuse, there is no environmental buffer required before connection to the drinking water system. Regulations do not currently exist for direct potable reuse in the United States. The only documented case of an operational direct potable reuse system is in Windhoek, Namibia. In the United States, this concept is currently being evaluated in Big Springs, Texas and Cloudcroft, New Mexico. Similar to indirect potable reuse, this approach must be evaluated in regards to health and safety standards, and its use must be understood by the public and policy makers. As stated above, SB 918 will address the regulatory approach to direct potable reuse by investigating the feasibility of developing uniform water recycling criteria for direct potable reuse by December 31, 2016. It is likely that successful applications of indirect potable reuse will eventually pave the way for future direct potable reuse opportunities.

C.6 Failsafe Disposal Requirements

Water reuse projects are required to have a mechanism to either store or divert water not meeting Federal and State water quality requirements. This backup mechanism is referred to as Failsafe Disposal, and it is one of the many requirements in place to protect the health and safety of residents. Failsafe Disposal is needed for a number of possible critical scenarios. When a treatment plant does not produce water meeting Federal or State water quality requirements (a condition known as off-specification water), the water must be stored or

diverted. In addition, wet weather events (occurring during larger rainstorms) and power failure conditions are scenarios that should be considered.

The following failsafe scenarios were analyzed in the Study:

- Off-specification condition for non-potable recycled water
- Off-specification condition for Advanced Water Purification Facility / indirect potable reuse water
- Off-specification condition for secondary effluent at the PLWTP
- Wet weather conditions
- Power failure conditions

The following failsafe disposal solutions were considered in the Study.

- Dedicated outfall
- Live stream discharge
- Discharge to the collection system and use of existing outfalls
- Storage
- Use of CEPT at the PLWTP until secondary effluent quality is restored

C.6.1 Biosolids Disposal

Biosolids disposal is regulated by multiple federal, state and local agencies. The regulatory environment is dynamic and proposed modifications are essentially continuous. The primary federal regulation for biosolids management is 40 Code of Federal Regulations 503 (Part 503 Rule) enforced by the EPA. In California, the Part 503 Rule is enforced through NPDES permits. Regulations under this rule address land application, surface disposal, and incineration of biosolids. The Part 503 Rule standards include pollutant limits, management practices and operational criteria, as well as monitoring, record keeping and reporting requirements for biosolids use and disposal. State agencies are allowed to impose more stringent requirements for using and disposing of biosolids beyond those specified in the Part 503 Rule. In California, the State Water Board, the Regional Water Board, the California Integrated Waste Management Board, and the California Department of Food and Agriculture are the primary state agencies responsible for regulating biosolids reuse and disposal. In addition, CDPH, Department of Toxic Substances Control, and California Air Resources Board regulate other aspects of biosolids disposal. Due to State budgetary constraints, the number of State agencies overseeing the disposal and reuse of biosolids may be reduced in the near future. It was assumed that the current regulations in place for the MBC will be maintained.

This page intentionally left blank.



APPENDIX D: SENATE BILL 918



This page intentionally left blank.

Senate Bill No. 918

CHAPTER 700

An act to amend Sections 13350 and 13521 of, and to add Chapter 7.3 (commencing with Section 13560) to Division 7 of, the Water Code, relating to water recycling.

[Approved by Governor September 30, 2010. Filed with Secretary of State September 30, 2010.]

LEGISLATIVE COUNSEL'S DIGEST

SB 918, Pavley. Water recycling.

(1) Existing law establishes the State Water Resources Control Board and the California regional water quality control boards as the principal state agencies with authority over matters relating to water quality. Existing law requires the State Department of Public Health to establish uniform statewide recycling criteria for each varying type of use for recycled water where the use involves the protection of public health.

This bill would require the State Department of Public Health to adopt uniform water recycling criteria for indirect potable water reuse for groundwater recharge, as defined, by December 31, 2013. The bill would require the department to develop and adopt uniform water recycling criteria for surface water augmentation, as defined, by December 31, 2016, if a specified expert panel convened pursuant to the bill finds that the criteria would adequately protect public health. The bill would require the department to investigate the feasibility of developing uniform water recycling criteria for direct potable reuse, as defined, and to provide a final report on that investigation to the Legislature by December 31, 2016. The bill would require the department, in consultation with the State Water Resources Control Board, to report to the Legislature from 2011 to 2016, inclusive, as part of the annual budget process, on the progress towards developing and adopting the water recycling criteria for surface water augmentation and its investigation of the feasibility of developing water recycling criteria for direct potable reuse. The bill would require the State Water Resources Control Board to enter into an agreement with the department to assist in implementing the water recycling criteria provisions.

(2) Existing law imposes specified civil liabilities for violations of water quality requirements, and requires all funds generated by the imposition of those liabilities to be deposited in the Waste Discharge Permit Fund. Existing law requires these moneys to be expended by the State Water Resources Control Board, upon appropriation by the Legislature, to assist California regional water quality control boards and other public agencies in cleaning up or abating the effects of waste on waters of the state.

This bill would require those funds to additionally be made available, upon appropriation by the Legislature, to the state board for purposes of assisting with the development and adoption of the water recycling criteria.

The people of the State of California do enact as follows:

SECTION 1. Section 13350 of the Water Code is amended to read:

13350. (a) A person who (1) violates a cease and desist order or cleanup and abatement order hereafter issued, reissued, or amended by a regional board or the state board, or (2) in violation of a waste discharge requirement, waiver condition, certification, or other order or prohibition issued, reissued, or amended by a regional board or the state board, discharges waste, or causes or permits waste to be deposited where it is discharged, into the waters of the state, or (3) causes or permits any oil or any residuary product of petroleum to be deposited in or on any of the waters of the state, except in accordance with waste discharge requirements or other actions or provisions of this division, shall be liable civilly, and remedies may be proposed, in accordance with subdivision (d) or (e).

(b) (1) A person who, without regard to intent or negligence, causes or permits a hazardous substance to be discharged in or on any of the waters of the state, except in accordance with waste discharge requirements or other provisions of this division, shall be strictly liable civilly in accordance with subdivision (d) or (e).

(2) For purposes of this subdivision, the term “discharge” includes only those discharges for which Section 13260 directs that a report of waste discharge shall be filed with the regional board.

(3) For purposes of this subdivision, the term “discharge” does not include an emission excluded from the applicability of Section 311 of the Clean Water Act (33 U.S.C. Sec. 1321) pursuant to Environmental Protection Agency regulations interpreting Section 311(a)(2) of the Clean Water Act (33 U.S.C. Sec. 1321(a)(2)).

(c) A person shall not be liable under subdivision (b) if the discharge is caused solely by any one or combination of the following:

(1) An act of war.

(2) An unanticipated grave natural disaster or other natural phenomenon of an exceptional, inevitable, and irresistible character, the effects of which could not have been prevented or avoided by the exercise of due care or foresight.

(3) Negligence on the part of the state, the United States, or any department or agency thereof. However, this paragraph shall not be interpreted to provide the state, the United States, or any department or agency thereof a defense to liability for any discharge caused by its own negligence.

(4) An intentional act of a third party, the effects of which could not have been prevented or avoided by the exercise of due care or foresight.

(5) Any other circumstance or event that causes the discharge despite the exercise of every reasonable precaution to prevent or mitigate the discharge.

(d) The court may impose civil liability either on a daily basis or on a per gallon basis, but not on both.

(1) The civil liability on a daily basis shall not exceed fifteen thousand dollars (\$15,000) for each day the violation occurs.

(2) The civil liability on a per gallon basis shall not exceed twenty dollars (\$20) for each gallon of waste discharged.

(e) The state board or a regional board may impose civil liability administratively pursuant to Article 2.5 (commencing with Section 13323) of Chapter 5 either on a daily basis or on a per gallon basis, but not on both.

(1) The civil liability on a daily basis shall not exceed five thousand dollars (\$5,000) for each day the violation occurs.

(A) When there is a discharge, and a cleanup and abatement order is issued, except as provided in subdivision (f), the civil liability shall not be less than five hundred dollars (\$500) for each day in which the discharge occurs and for each day the cleanup and abatement order is violated.

(B) When there is no discharge, but an order issued by the regional board is violated, except as provided in subdivision (f), the civil liability shall not be less than one hundred dollars (\$100) for each day in which the violation occurs.

(2) The civil liability on a per gallon basis shall not exceed ten dollars (\$10) for each gallon of waste discharged.

(f) A regional board shall not administratively impose civil liability in accordance with paragraph (1) of subdivision (e) in an amount less than the minimum amount specified, unless the regional board makes express findings setting forth the reasons for its action based upon the specific factors required to be considered pursuant to Section 13327.

(g) The Attorney General, upon request of a regional board or the state board, shall petition the superior court to impose, assess, and recover the sums. Except in the case of a violation of a cease and desist order, a regional board or the state board shall make the request only after a hearing, with due notice of the hearing given to all affected persons. In determining the amount to be imposed, assessed, or recovered, the court shall be subject to Section 13351.

(h) Article 3 (commencing with Section 13330) and Article 6 (commencing with Section 13360) apply to proceedings to impose, assess, and recover an amount pursuant to this article.

(i) A person who incurs any liability established under this section shall be entitled to contribution for that liability from a third party, in an action in the superior court and upon proof that the discharge was caused in whole or in part by an act or omission of the third party, to the extent that the discharge is caused by the act or omission of the third party, in accordance with the principles of comparative fault.

(j) Remedies under this section are in addition to, and do not supersede or limit, any and all other remedies, civil or criminal, except that no liability

shall be recoverable under subdivision (b) for any discharge for which liability is recovered under Section 13385.

(k) Notwithstanding any other law, all funds generated by the imposition of liabilities pursuant to this section shall be deposited into the Waste Discharge Permit Fund. These moneys shall be separately accounted for, and shall be expended by the state board, upon appropriation by the Legislature, to assist regional boards, and other public agencies with authority to clean up waste or abate the effects of the waste, in cleaning up or abating the effects of the waste on waters of the state, or for the purposes authorized in Section 13443, or to assist in implementing Chapter 7.3 (commencing with Section 13560).

SEC. 2. Section 13521 of the Water Code is amended to read:

13521. The State Department of Public Health shall establish uniform statewide recycling criteria for each varying type of use of recycled water where the use involves the protection of public health.

SEC. 3. Chapter 7.3 (commencing with Section 13560) is added to Division 7 of the Water Code, to read:

CHAPTER 7.3. DIRECT AND INDIRECT POTABLE REUSE

13560. The Legislature finds and declares the following:

(a) In February 2009, the state board unanimously adopted, as Resolution No. 2009-0011, an updated water recycling policy, which includes the goal of increasing the use of recycled water in the state over 2002 levels by at least 1,000,000 acre-feet per year by 2020 and by at least 2,000,000 acre-feet per year by 2030.

(b) Section 13521 requires the department to establish uniform statewide recycling criteria for each varying type of use of recycled water where the use involves the protection of public health.

(c) The use of recycled water for indirect potable reuse is critical to achieving the state board's goals for increased use of recycled water in the state. If direct potable reuse can be demonstrated to be safe and feasible, implementing direct potable reuse would further aid in achieving the state board's recycling goals.

(d) Although there has been much scientific research on public health issues associated with indirect potable reuse through groundwater recharge, there are a number of significant unanswered questions regarding indirect potable reuse through surface water augmentation and direct potable reuse.

(e) Achievement of the state's goals depends on the timely development of uniform statewide recycling criteria for indirect and direct potable water reuse.

(f) This chapter is not intended to delay, invalidate, or reverse any study or project, or development of regulations by the department, the state board, or the regional boards regarding the use of recycled water for indirect potable reuse for groundwater recharge, surface water augmentation, or direct potable reuse.

(g) This chapter shall not be construed to delay, invalidate, or reverse the department's ongoing review of projects consistent with Section 116551 of the Health and Safety Code.

13561. For purposes of this chapter, the following terms have the following meanings:

(a) "Department" means the State Department of Public Health.

(b) "Direct potable reuse" means the planned introduction of recycled water either directly into a public water system, as defined in Section 116275 of the Health and Safety Code, or into a raw water supply immediately upstream of a water treatment plant.

(c) "Indirect potable reuse for groundwater recharge" means the planned use of recycled water for replenishment of a groundwater basin or an aquifer that has been designated as a source of water supply for a public water system, as defined in Section 116275 of the Health and Safety Code.

(d) "Surface water augmentation" means the planned placement of recycled water into a surface water reservoir used as a source of domestic drinking water supply.

(e) "Uniform water recycling criteria" has the same meaning as in Section 13521.

13561.5. The state board shall enter into an agreement with the department to assist in implementing this chapter.

13562. (a) (1) On or before December 31, 2013, the department shall adopt uniform water recycling criteria for indirect potable reuse for groundwater recharge.

(2) (A) Except as provided in subparagraph (C), on or before December 31, 2016, the department shall develop and adopt uniform water recycling criteria for surface water augmentation.

(B) Prior to adopting uniform water recycling criteria for surface water augmentation, the department shall submit the proposed criteria to the expert panel convened pursuant to subdivision (a) of Section 13565. The expert panel shall review the proposed criteria and shall adopt a finding as to whether, in its expert opinion, the proposed criteria would adequately protect public health.

(C) The department shall not adopt uniform water recycling criteria for surface water augmentation pursuant to subparagraph (A), unless and until the expert panel adopts a finding that the proposed criteria would adequately protect public health.

(b) Adoption of uniform water recycling criteria by the department is subject to the requirements of Chapter 3.5 (commencing with Section 11340) of Part 1 of Division 3 of Title 2 of the Government Code.

13563. (a) (1) The department shall investigate and report to the Legislature on the feasibility of developing uniform water recycling criteria for direct potable reuse.

(2) The department shall complete a public review draft of its report by June 30, 2016. The department shall provide the public not less than 45 days to review and comment on the public review draft.

(3) The department shall provide a final report to the Legislature by December 31, 2016. The department shall make the final report available to the public.

(b) In conducting the investigation pursuant to subdivision (a), the department shall examine all of the following:

(1) The availability and reliability of recycled water treatment technologies necessary to ensure the protection of public health.

(2) Multiple barriers and sequential treatment processes that may be appropriate at wastewater and water treatment facilities.

(3) Available information on health effects.

(4) Mechanisms that should be employed to protect public health if problems are found in recycled water that is being served to the public as a potable water supply, including, but not limited to, the failure of treatment systems at the recycled water treatment facility.

(5) Monitoring needed to ensure protection of public health, including, but not limited to, the identification of appropriate indicator and surrogate constituents.

(6) Any other scientific or technical issues that may be necessary, including, but not limited to, the need for additional research.

(c) (1) Notwithstanding Section 10231.5 of the Government Code, the requirement for submitting a report imposed under paragraph (3) of subdivision (a) is inoperative on December 31, 2020.

(2) A report to be submitted pursuant to paragraph (3) of subdivision (a) shall be submitted in compliance with Section 9795 of the Government Code.

13563.5. (a) The department, in consultation with the state board, shall report to the Legislature as part of the annual budget process, in each year from 2011 to 2016, inclusive, on the progress towards developing and adopting uniform water recycling criteria for surface water augmentation and its investigation of the feasibility of developing uniform water recycling criteria for direct potable reuse.

(b) (1) A written report submitted pursuant to subdivision (a) shall be submitted in compliance with Section 9795 of the Government Code.

(2) Pursuant to Section 10231.5 of the Government Code, this section is repealed on January 1, 2017.

13564. In developing uniform recycling criteria for surface water augmentation, the department shall consider all of the following:

(a) The final report from the National Water Research Institute Independent Advisory Panel for the City of San Diego Indirect Potable Reuse/Reservoir Augmentation (IPR/RA) Demonstration Project.

(b) Monitoring results of research and studies regarding surface water augmentation.

(c) Results of demonstration studies conducted for purposes of approval of projects using surface water augmentation.

(d) Epidemiological studies and risk assessments associated with projects using surface water augmentation.

(e) Applicability of the advanced treatment technologies required for recycled water projects, including, but not limited to, indirect potable reuse for groundwater recharge projects.

(f) Water quality, limnology, and health risk assessments associated with existing potable water supplies subject to discharges from municipal wastewater, stormwater, and agricultural runoff.

(g) Recommendations of the State of California Constituents of Emerging Concern Recycled Water Policy Science Advisory Panel.

(h) State funded research pursuant to Section 79144 and subdivision (b) of Section 79145.

(i) Research and recommendations from the United States Environmental Protection Agency Guidelines for Water Reuse.

(j) Other relevant research and studies regarding indirect potable reuse of recycled water.

13565. (a) (1) The department shall convene and administer an expert panel for the purposes of advising the department on public health issues and scientific and technical matters regarding development of uniform water recycling criteria for indirect potable reuse through surface water augmentation and investigation of the feasibility of developing uniform water recycling criteria for direct potable reuse.

(2) The expert panel shall be comprised, at a minimum, of a toxicologist, an engineer licensed in the state with at least three years' experience in wastewater treatment, an engineer licensed in the state with at least three years' experience in treatment of drinking water supplies and knowledge of drinking water standards, an epidemiologist, a microbiologist, and a chemist.

(3) Members of the expert panel may be reimbursed for reasonable and necessary travel expenses.

(b) (1) The department may appoint an advisory group, task force, or other group, comprised of no fewer than nine representatives of water and wastewater agencies, local public health officers, environmental organizations, environmental justice organizations, public health nongovernmental organizations, and the business community, to advise the department regarding the development of uniform water recycling criteria for direct potable reuse.

(2) Environmental, environmental justice, and public health nongovernmental organization representative members of the advisory group, task force, or other group may be reimbursed for reasonable and necessary travel expenses.

13566. In performing its investigation of the feasibility of developing the uniform water recycling criteria for direct potable reuse, the department shall consider all of the following:

(a) Recommendations from the expert panel appointed pursuant to subdivision (a) of Section 13565.

(b) Recommendations from an advisory group, task force, or other group appointed by the department pursuant to subdivision (b) of Section 13565.

(c) Regulations and guidelines for these activities from jurisdictions in other states, the federal government, or other countries.

(d) Research by the state board regarding unregulated pollutants, as developed pursuant to Section 10 of the recycled water policy adopted by state board Resolution No. 2009-0011.

(e) Results of investigations pursuant to Section 13563.

(f) Water quality and health risk assessments associated with existing potable water supplies subject to discharges from municipal wastewater, stormwater, and agricultural runoff.

13567. An action authorized pursuant to this chapter shall be consistent, to the extent applicable, with the federal Clean Water Act (33 U.S.C. Sec. 1251 et seq.), the federal Safe Drinking Water Act (42 U.S.C. Sec. 300f et seq.), this division, and the California Safe Drinking Water Act (Chapter 4 (commencing with Section 116270) of Part 12 of Division 104 of the Health and Safety Code).

13569. The department may accept funds from any source, and may expend these funds, upon appropriation by the Legislature, for the purposes of this chapter.

APPENDIX E: SITING ANALYSIS DOCUMENTS



This page intentionally left blank.



THE CITY OF SAN DIEGO
PUBLIC UTILITIES
DEPARTMENT



City of San Diego's Recycled Water Study

Proposed NTC Treatment Site

January 2011

Public Utilities Department





Metropolitan Sewerage System

- Population Served: 2.2M
- Participating Agencies: 16
- Sewer Mains: 3,000 miles
- Pump Stations: 83
- Treatment Capacity: 240 mgd at Point Loma Wastewater Treatment Plant
- Water Reclamation Plant Capacity: 45 mgd
- Metro Biosolids Center

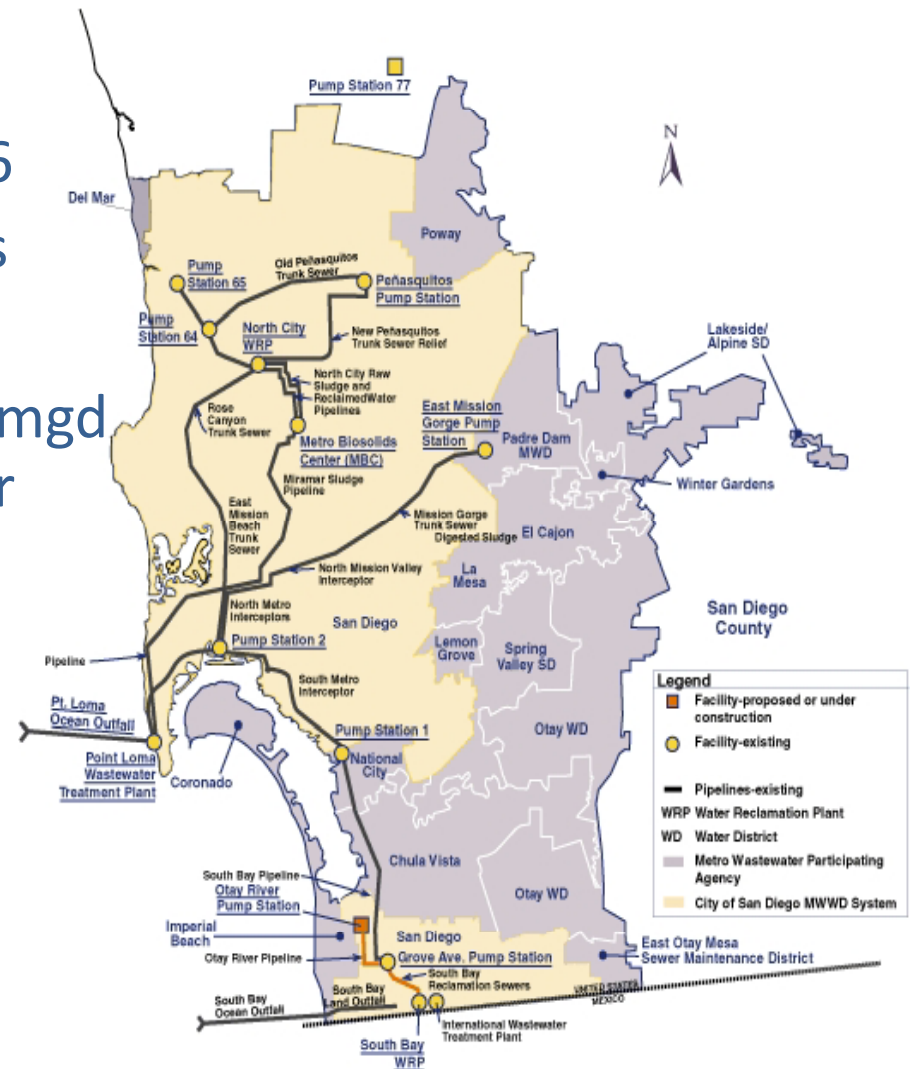



Siting Analysis



- NTC Site
- Fiesta Island Site
- Pump Station 1 Site









Criteria

Number	Criteria	Objective
1	Health and Safety	To protect human health and safety with regard to recycled water use and wastewater conveyance
2	Social Value	To maximize beneficial use of recycled water with regard to quality of life and equal service to all socioeconomic groups
3	Environmental Value	To enhance, create or improve local habitat or ecosystems and avoid or minimize negative environmental impacts
4	Local Water Reliability	To substantially increase the percentage of water supply that comes from water reuse, thereby offsetting the need for imported water
5	Water Quality	Meets or exceeds level of quality required for the intended use and customer needs
6	Operational Reliability	To maximize ability of facilities to perform under a range of future conditions
7	Cost	To minimize total cost to the community
8	Ability to Implement	To evaluate viability or fatal flaws and assess political and public acceptability



SITE COMPARISON

No.	Criteria	NTC Site	Fiesta Island Site	Pump Station 1 Site
1	Health and Safety	<ul style="list-style-type: none">• Minimize wastewater pumping• Proximity to North Metro Interceptor and South Metro Interceptor	<ul style="list-style-type: none">• Greater risk with wastewater pumping (50-60 mgd)	<ul style="list-style-type: none">• Greatest risk with wastewater pumping (50-60 mgd)
2	Social Value	<ul style="list-style-type: none">• Provides a high social value	<ul style="list-style-type: none">• Provides a high social value	<ul style="list-style-type: none">• Provides a high social value
3	Environmental Value	<ul style="list-style-type: none">• Smallest carbon footprint• Least risk to environment• No wastewater pumping	<ul style="list-style-type: none">• Larger carbon footprint• Higher risk to environment when pumping wastewater• Larger environmental impact	<ul style="list-style-type: none">• Largest carbon footprint• Risk to environment when pumping wastewater.• Largest environmental impact
4	Local Water Reliability	<ul style="list-style-type: none">• Due to reduced number of facilities the risk of facility failure is much less, thus this provided higher water reliability	<ul style="list-style-type: none">• Lower Reliability due to a number of new facilities	<ul style="list-style-type: none">• Lowest Reliability due to a number of new facilities



SITE COMPARISON

No.	Criteria	NTC Site	Fiesta Island Site	Pump Station 1 Site
5	Water Quality	<ul style="list-style-type: none">• All options will have the same finished water quality	<ul style="list-style-type: none">• All options will have the same finished water quality	<ul style="list-style-type: none">• All options will have the same finished water quality
6	Operational Reliability	<ul style="list-style-type: none">• Easier to operate• More Reliable	<ul style="list-style-type: none">• Less reliable• More facilities needed• More complex operation	<ul style="list-style-type: none">• Least reliable
7	Cost	<ul style="list-style-type: none">• Lowest cost	<ul style="list-style-type: none">• Higher cost	<ul style="list-style-type: none">• Highest cost
8	Ability to Implement	<ul style="list-style-type: none">• Site acquisition drives implementation• More desirable than pumping wastewater• Easier to implement	<ul style="list-style-type: none">• Site acquisition drives implementation.• Less desirable due to pumping wastewater• More Difficult to implement	<ul style="list-style-type: none">• Site acquisition drives implementation.• Less desirable due to pumping wastewater and longer forcemain• Most difficult to implement



Conclusion

Site	Capital Cost ⁽¹⁾	Annual O&M Cost ⁽¹⁾
Fiesta Island	\$247 M	\$3.7 M
PS1	\$371 M	\$4.2 M

1. The cost shown is an additional cost the City would incur by moving the site from the NTC site to either the Fiesta Island or PS1 site.



Diversion Options



San Vicente – Theme A1

Maximize secondary at North City (45 mgd); AWPf at Stadium

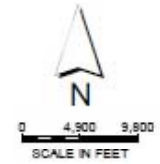
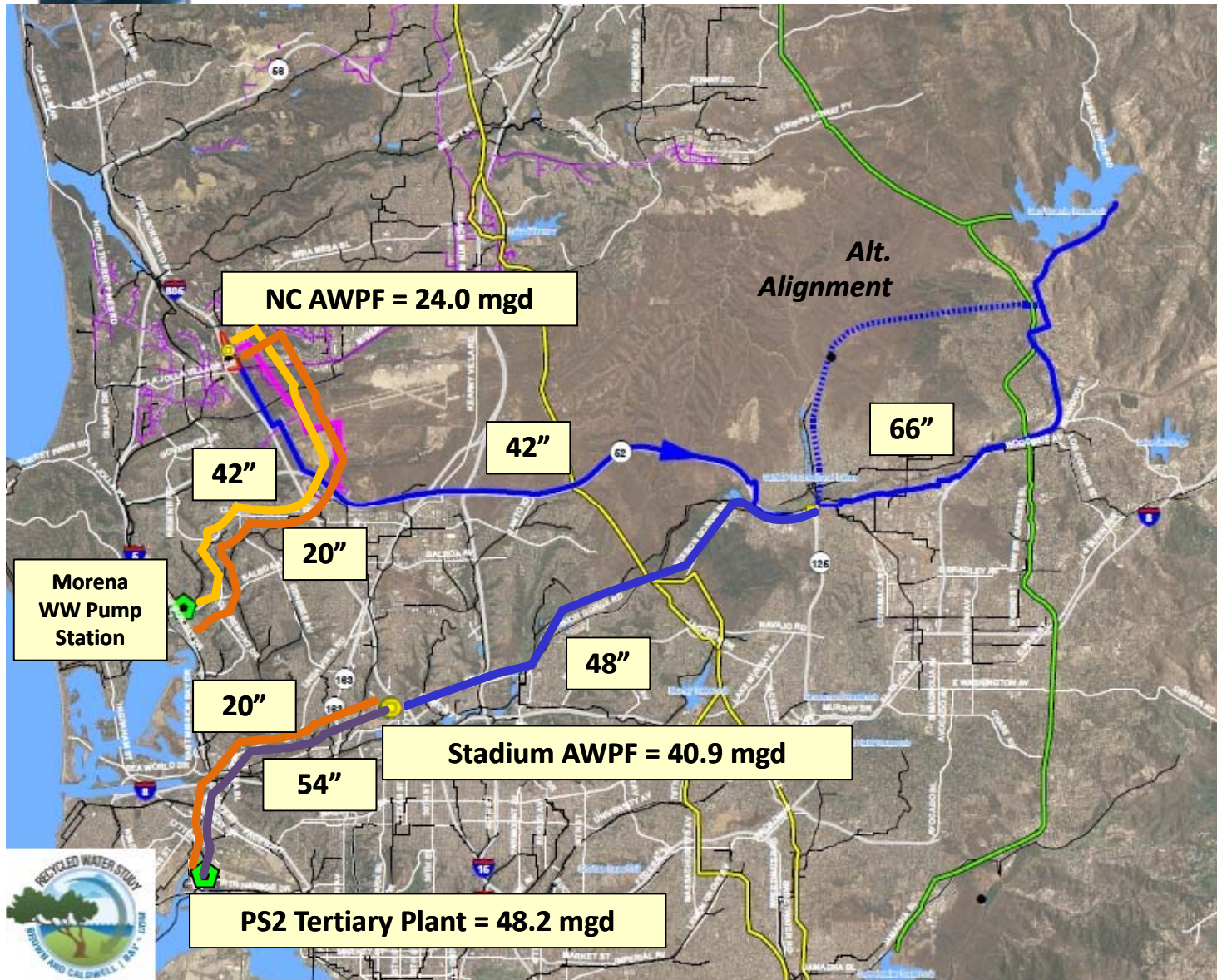

- LEGEND**
- Existing Treatment Plant
 - New Pump Station
 - New AWPf
 - New Distribution System
 - New Distribution System Alternate
 - New Tertiary Water Pipeline
 - New Brine Line
 - Waste Line
 - Sludge Line
 - 1st San Diego Aqueduct
 - 2nd San Diego Aqueduct
 - Existing Recycled Water Pipeline
 - Existing Metro System Trunk Sewers

DRAFT
WORK IN PROGRESS

SAN VICENTE
OPTIONS

Draft work product





San Vicente – Theme A2

Maximize secondary at North City (45 mgd); AWPf at PS2

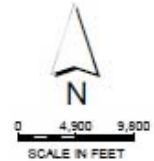
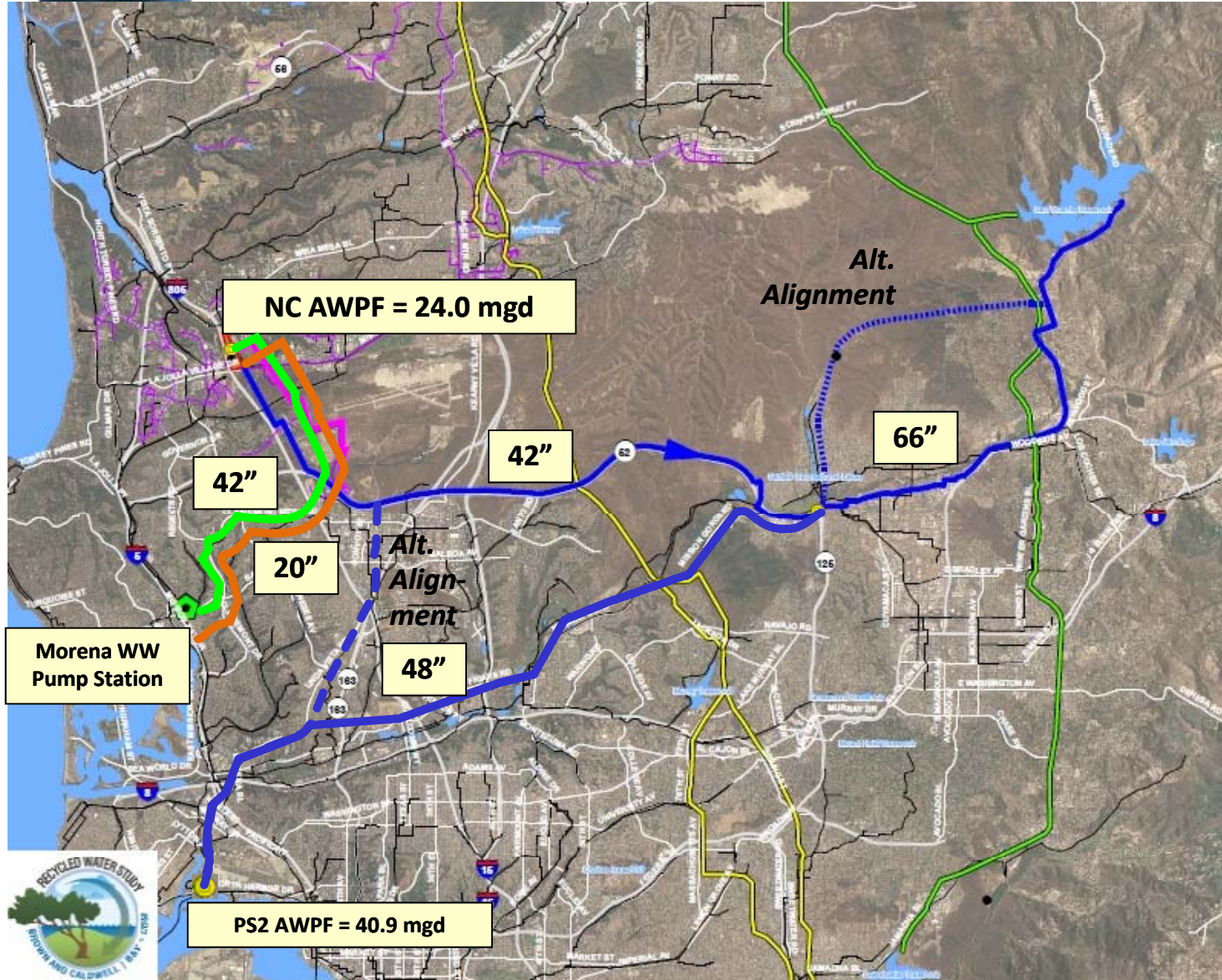

LEGEND

- Existing Treatment Plant
- ◀ New Pump Station
- New AWPf
- New Distribution System
- - - New Distribution System Alternate
- New Tertiary Water Pipeline
- New Brine Line
- Waste Line
- Sludge Line
- 1st San Diego Aqueduct
- 2nd San Diego Aqueduct
- Existing Recycled Water Pipeline
- Existing Metro System Trunk Sewers

DRAFT
WORK IN PROGRESS

SAN VICENTE
OPTIONS

Draft work product



San Vicente – Theme B1

Maximize existing North City (30 mgd); AWPf at Stadium

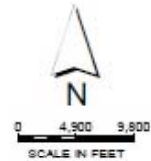
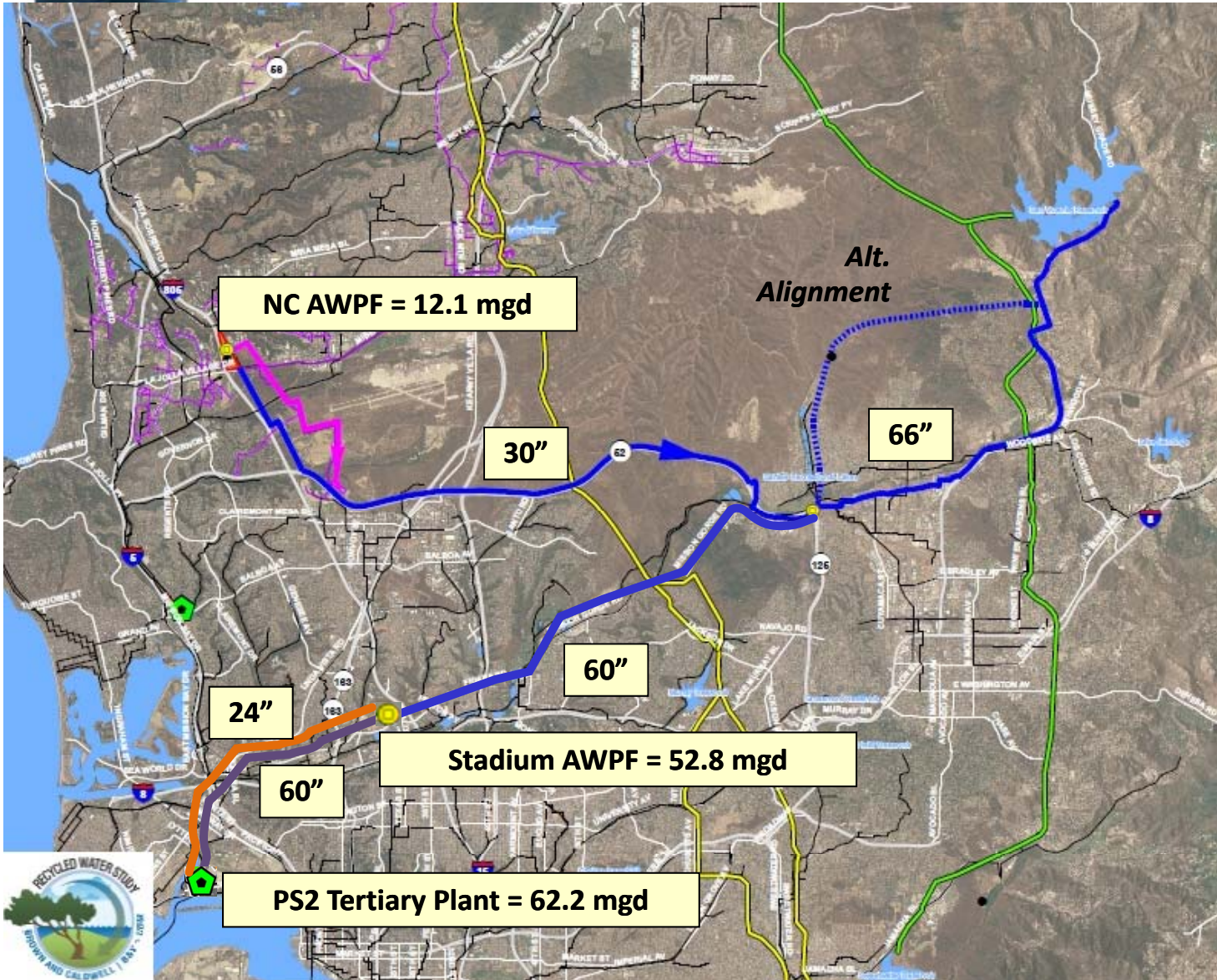

LEGEND

- Existing Treatment Plant
- 🟩 New Pump Station
- New AWPf
- New Distribution System
- - - New Distribution System Alternate
- New Tertiary Water Pipeline
- New Brine Line
- Waste Line
- Sludge Line
- 1st San Diego Aqueduct
- 2nd San Diego Aqueduct
- Existing Recycled Water Pipeline
- Existing Metro System Trunk Sewers

DRAFT
WORK IN PROGRESS

SAN VICENTE
OPTIONS

Draft work product



San Vicente – Theme B2

Maximize existing North City (30 mgd); AWPf at PS2

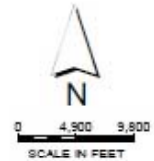
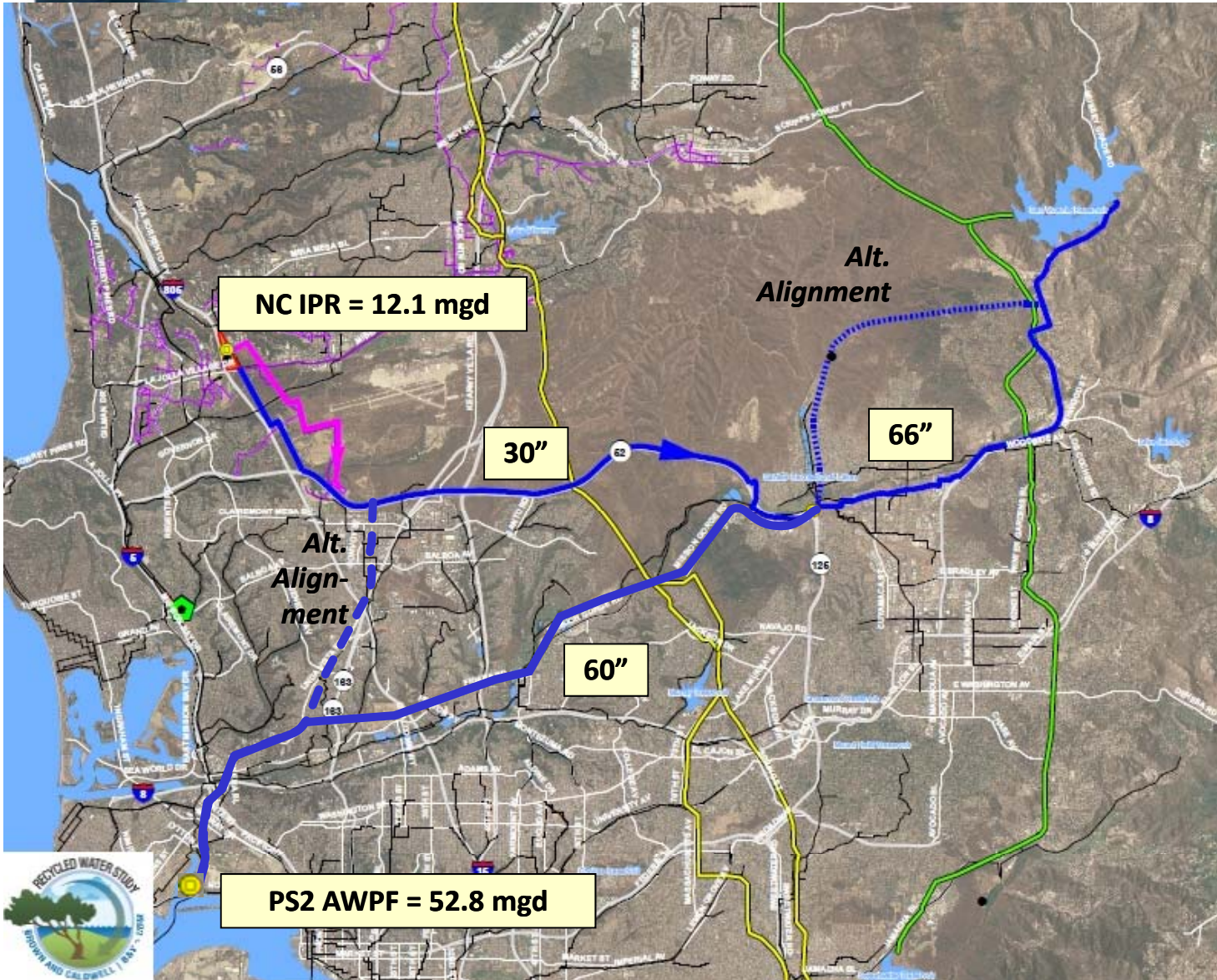

LEGEND

- Existing Treatment Plant
- New Pump Station
- New AWPf
- New Distribution System
- - - New Distribution System Alternate
- New Tertiary Water Pipeline
- New Brine Line
- Waste Line
- Sludge Line
- 1st San Diego Aqueduct
- 2nd San Diego Aqueduct
- Existing Recycled Water Pipeline
- Existing Metro System Trunk Sewers

DRAFT
WORK IN PROGRESS

SAN VICENTE
OPTIONS

Draft work product



PS2 Site



Draft work product



THE CITY OF SAN DIEGO
PUBLIC UTILITIES
DEPARTMENT



Why is the Site Critical to Water & Wastewater?

- Proximity to PS2
- PS2 Age
- Location of a wet-weather facility
- Provide significant relief to the PLWTP

November 2, 2010





Recycled Water Study

Q & A

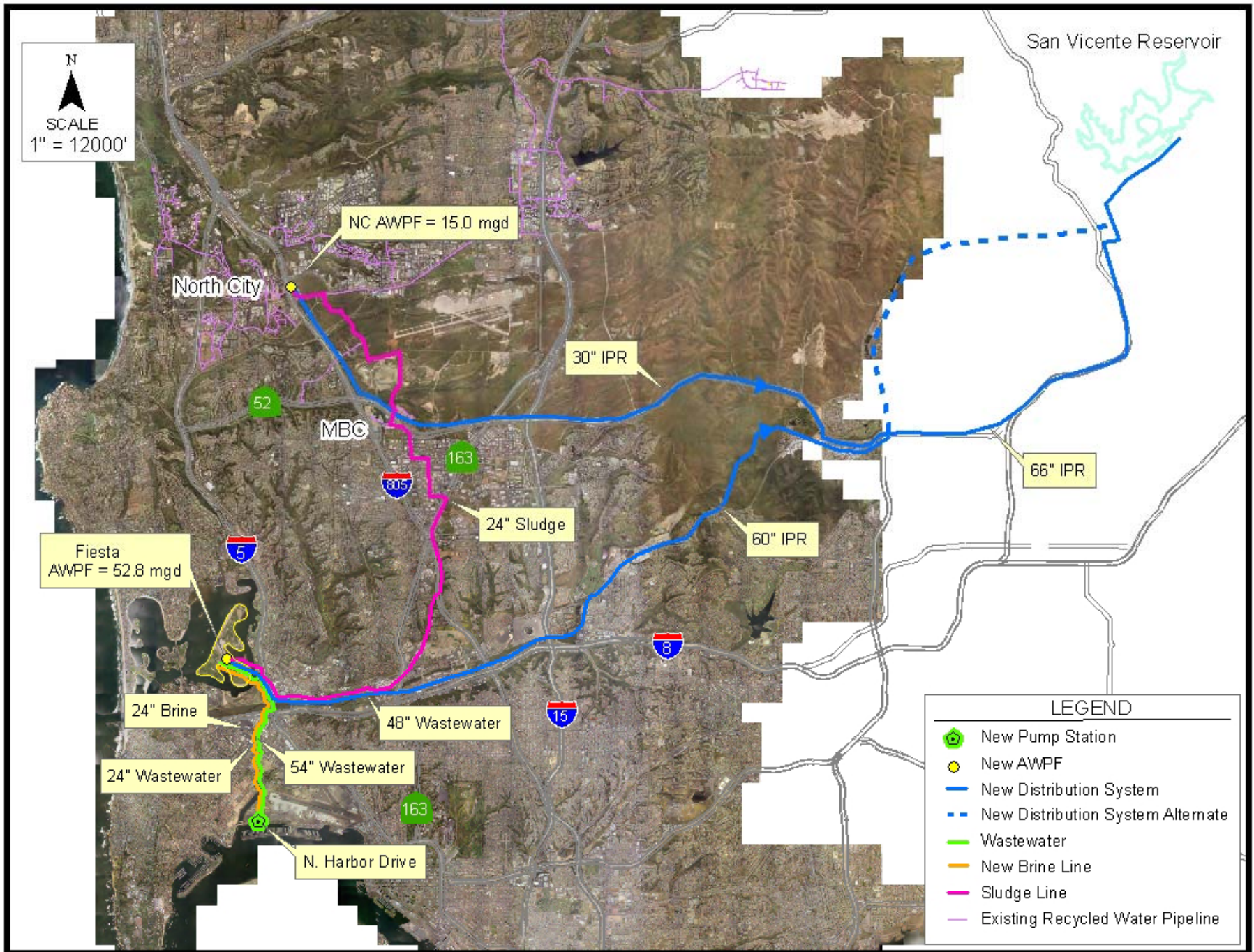

N
 SCALE
 1" = 12000'

San Vicente Reservoir

NC AWWPF = 15.0 mgd

North City

30" IPR

MBC

66" IPR

24" Sludge

60" IPR

Fiesta
 AWWPF = 52.8 mgd

24" Brine

48" Wastewater

24" Wastewater

54" Wastewater

N. Harbor Drive

LEGEND

- New Pump Station
- New AWWPF
- New Distribution System
- New Distribution System Alternate
- Wastewater
- New Brine Line
- Sludge Line
- Existing Recycled Water Pipeline

Fiesta Island Treatment Plant Option

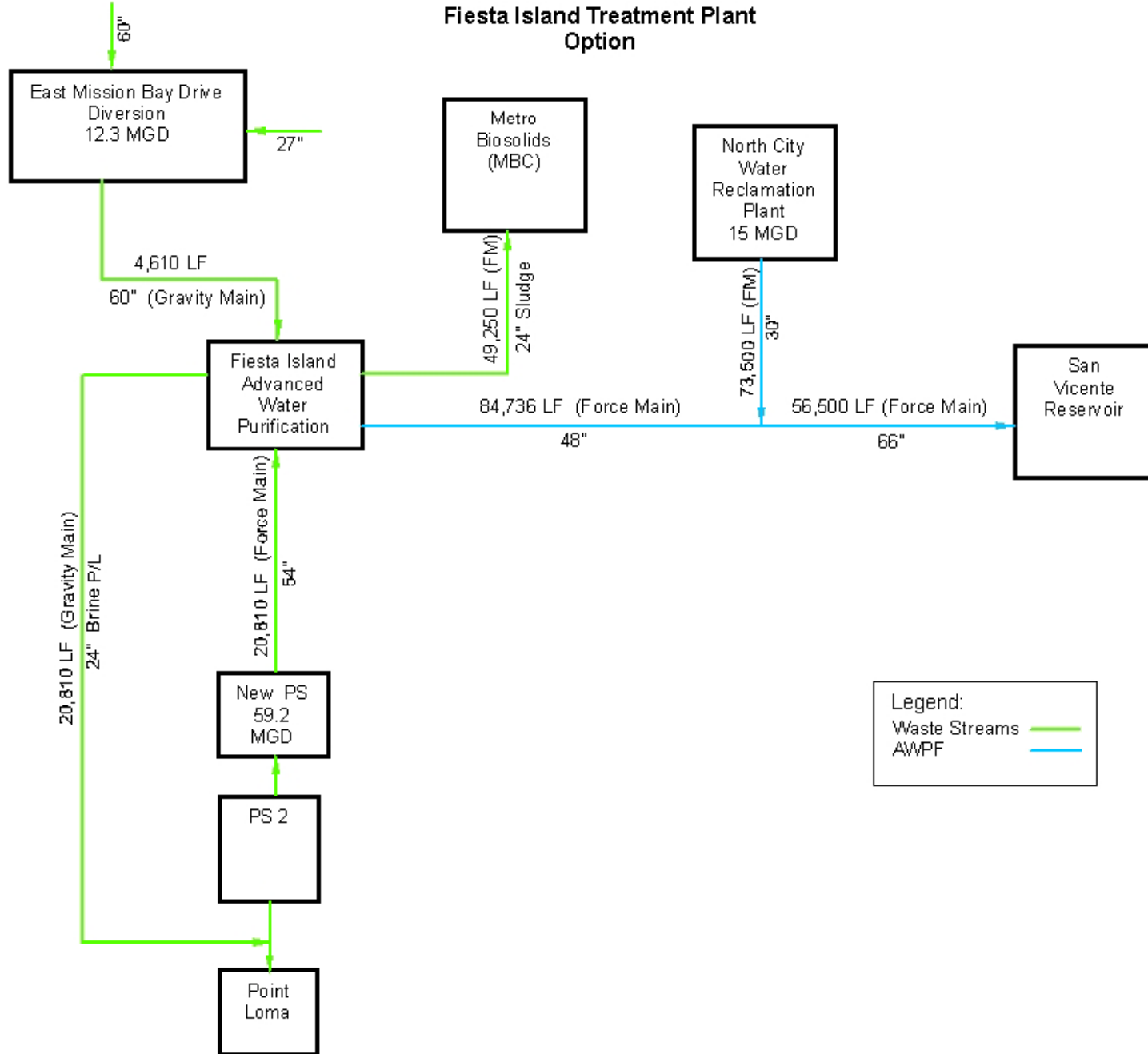

NC at 30 + Harbor Drive WW Diversion + Fiesta Island WRP/AWPF

Item	Cost
NCWRP AWPF Treatment Plant Sub-total	\$80,024,435.40
Wastewater Diversion from Pump Station 2 to Fiesta Island sub-total	\$110,979,246.00
Diversion of Wastewater Flow at East Mission Bay Drive sub-total	\$4,561,410.00
Fiesta Island Wastewater Treatment Plant Sub-total	\$412,163,466.00
Sludge Pumping from Fiesta Island to MBC Sub-total	\$124,573,560.00
Brine from Fiesta Island to PS-2 sub-total	\$25,884,750.00
IPR Treatment Plant at Fiesta Island sub-total	\$147,241,026.80
IPR Service Sub -total	\$227,446,926.00
Sub Total	\$1,132,874,820.20
Soft Cost	
Contingency	\$453,149,928.08
EL & A	\$226,574,964.04
Environmental	\$226,574,964.04
Construction Management	\$113,287,482.02
Land Acquisition	\$45,314,992.81
Total Cost	\$2,197,777,151.19

Additional Structures:

- a) 59.2 MGD wastewater pump station from Harbor Drive to Fiesta Island site
- b) Sludge line from Fiesta Island site to MBC
- c) Brine line from Fiesta Island site to PS-2
- d) Diversion structure at the East Mission Bay TS (12.3 mgd)
- e) Fiesta Island WRP/AWPF

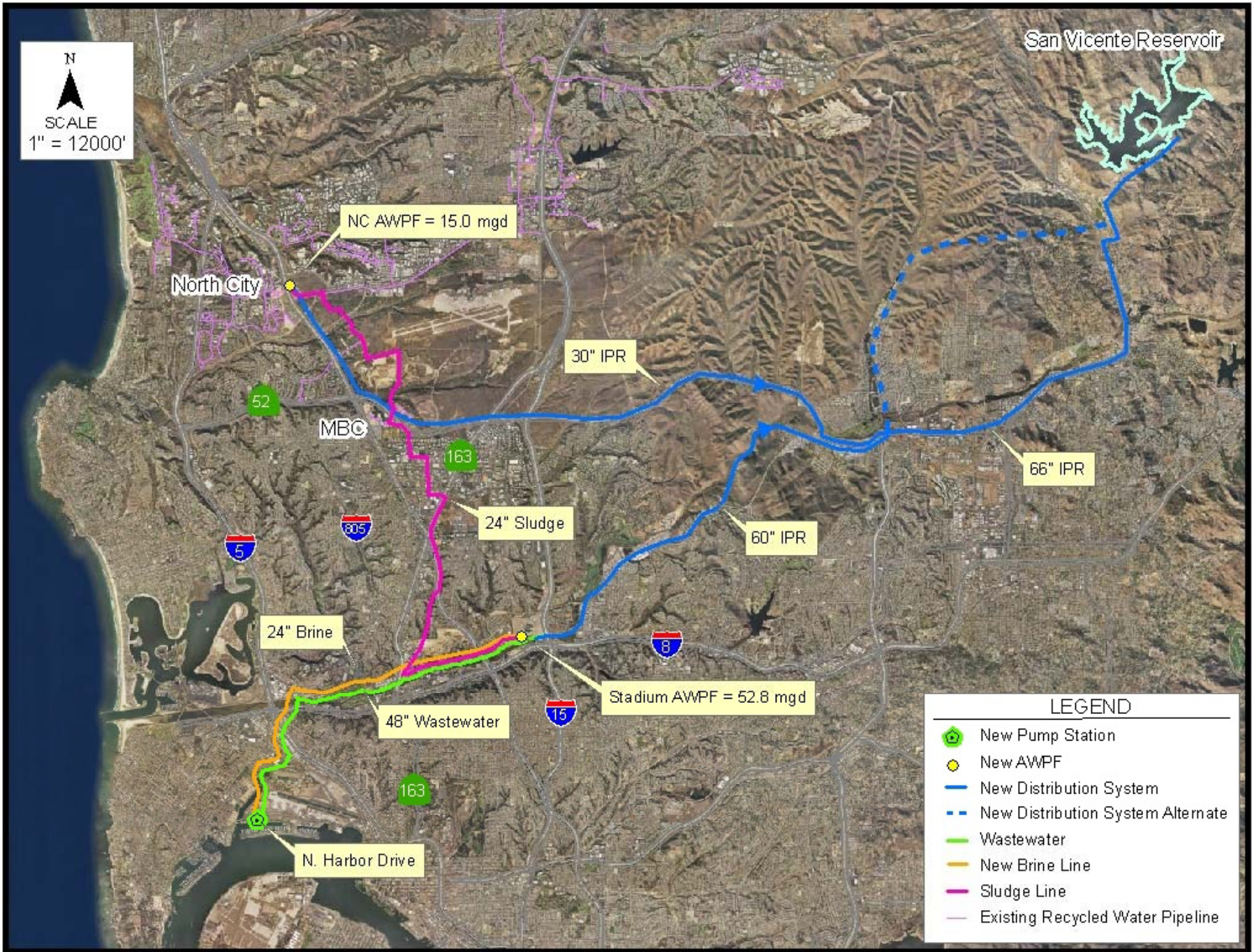

N
 SCALE
 1" = 12000'

San Vicente Reservoir

NC AWPf = 15.0 mgd

North City

30" IPR

52

MBC

163

24" Sludge

60" IPR

66" IPR

5

605

24" Brine

8

Stadium AWPf = 52.8 mgd

15

48" Wastewater

163

N. Harbor Drive

LEGEND

- New Pump Station
- New AWPf
- New Distribution System
- New Distribution System Alternate
- Wastewater
- New Brine Line
- Sludge Line
- Existing Recycled Water Pipeline

Qualcomm Treatment Plant

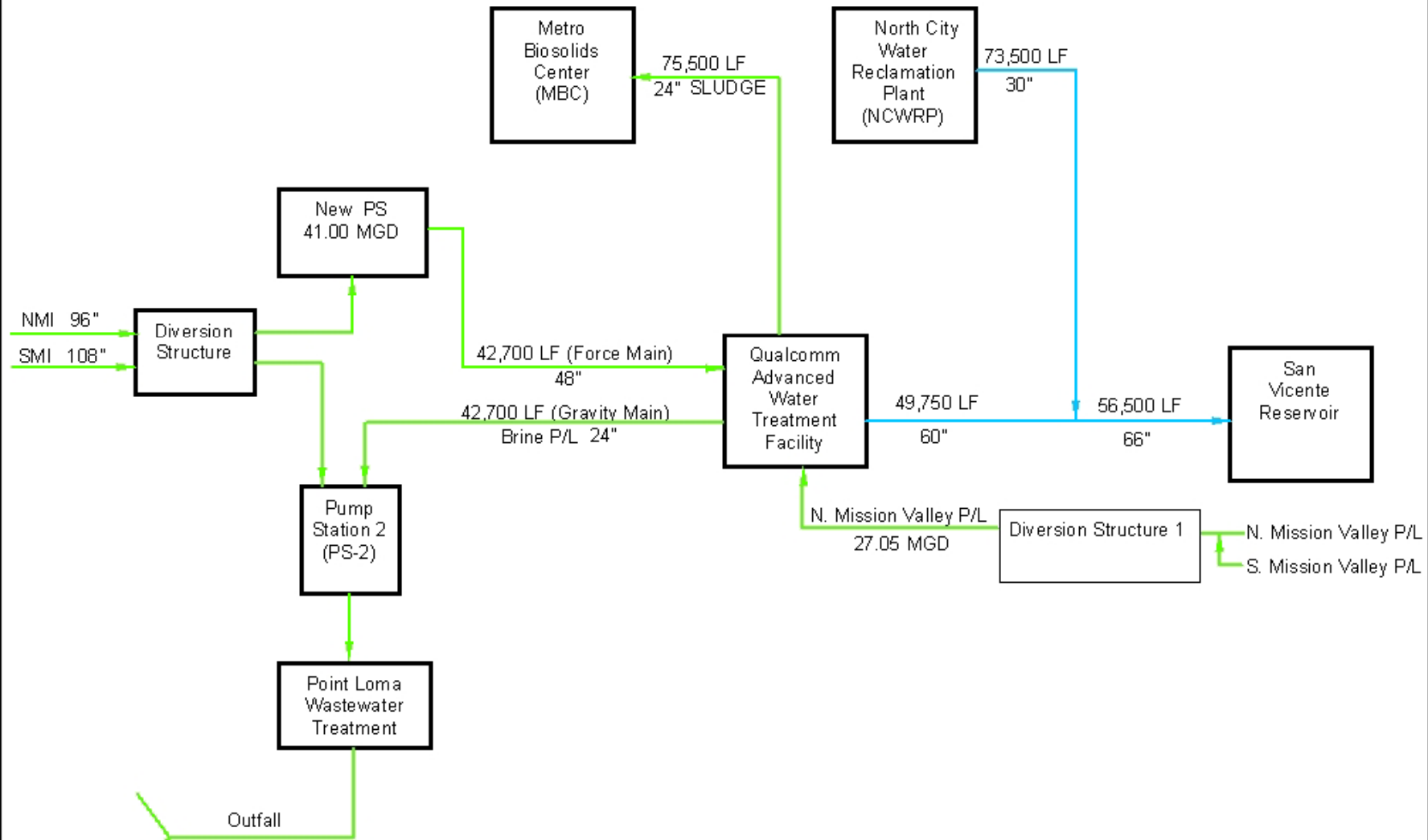

Legend:
 Waste Streams ———
 AWWPF ———

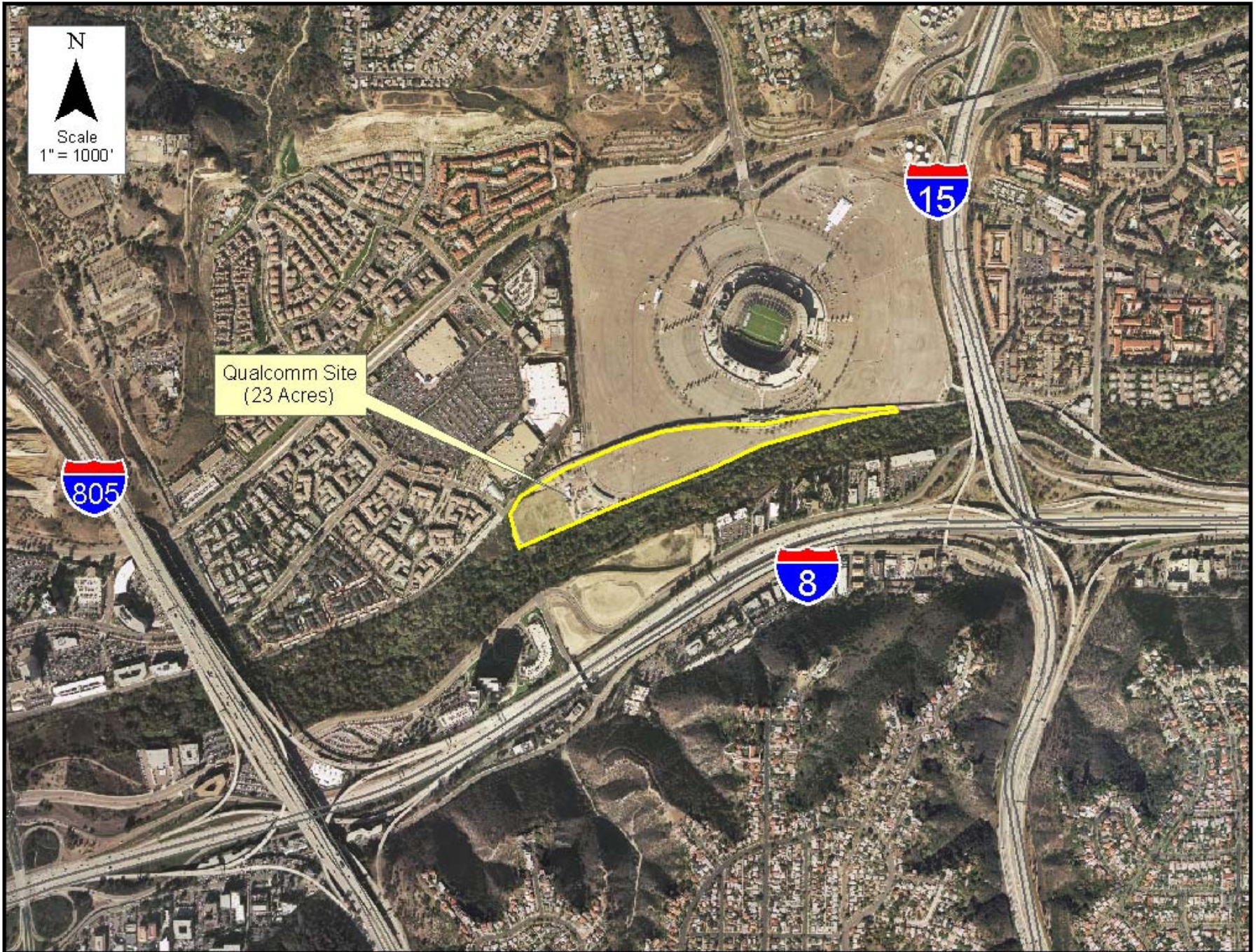

N
Scale
1" = 1000'

Qualcomm Site
(23 Acres)



NC at 30 + Harbor Drive WW Diversion + Qualcomm Stadium WRP/AWPF

Item	Capital Cost
NCWRP AWPF Treatment Plant Sub-Total	\$80,024,435.40
Harbor Drive Diversion PS Sub-Total	\$140,221,843.00
Wastewater Diversion at North Mission Valley Interceptor	\$1,518,000.00
PS-2 Influent Wastewater Diversion Sub-Total	\$1,835,000.00
Qualcomm Wastewater Treatment Sub-total	\$412,163,466.00
Qualcomm Sludge Pumping Sub-total	\$129,767,800.00
Qualcomm Brine Pipeline Sub-total	\$55,384,900.00
Qualcomm AWPF Sub-total	\$106,212,272.40
IPR Pump Station Sub-total	\$34,571,856.00
IPR Conveyance System Sub-total	\$172,644,100.00
Sub Total	\$1,134,343,672.80
Soft Cost	
Contingency	\$453,737,469.12
EL & A	\$226,868,734.56
Environmental	\$226,868,734.56
Construction Management	\$113,434,367.28
Land Acquisition	\$45,373,746.91
Total Cost	\$2,200,626,725.23

Additional Structures:

- a) 41 MGD wastewater pump station from Harbor Drive to Qualcomm site
- b) Additional Sludge line & pump station from Qualcomm site to MBC
- c) Additional Brine line from Qualcomm site to PS-2
- d) Diversion structure at the North Mission Valley TS
- e) Diversion Structure at PS-2 Influent

This page intentionally left blank.

APPENDIX F: CONCEPTUAL COST ESTIMATES FOR THE INTEGRATED REUSE ALTERNATIVES

This page intentionally left blank.

Theme A1 - NC at 45 + Harbor Drive Tertiary + Stadium AWPf

Item	Description	Total Capacity		Unit	Pipe Diameter ^b	Construction Factor	CAPITAL COST				O&M				Total Annual Cost
		Average	Peak				Unit Cost	Unit	Quantity ^a	Cost	Chemical Cost	Energy Cost	Labor Cost	Other Cost	
TREATMENT UP TO AOP															
NCWRP Upgrades/Improvements															
Influent Pump Station	Upgrade existing influent PS	45.2	90.4	mgd	---	1	\$0	mgd	15.2	\$0					
Preliminary	Conventional	45.2	90.4	mgd	---	1	\$1,509,725	mgd	15.2	\$22,947,823					
Primary	Conventional	45.2	90.4	mgd	---	1	\$937,044	mgd	15.2	\$14,243,070					
Secondary	Conventional	45.2	90.4	mgd	---	1	\$3,188,199	mgd	15.2	\$48,460,618					
Tertiary															
Filtration	Provided by MF Below	0.0	0.0	mgd	---	3	\$0	mgd		N/A					
Disinfection	Chlorination (Existing Capacity Adequate)	0.0	0.0	mgd	---	3	\$0	mgd	0.0	N/A					
NCWRP TERTIARY TREATMENT COST SUBTOTAL										\$85,651,511	\$318,544	\$1,079,586	\$1,048,170	\$676,679	\$3,122,979
AWPF	MF (To replace existing granular filters)	44.6	58.0	mgd	---	4	\$1,225,021	mgd	44.6	\$54,686,539					\$7,067,857
	RO (Includes 1.5 mgd permeate for blending)	33.0	42.9	mgd	---	2	\$1,518,190	mgd	33.0	\$50,054,717					\$11,464,887
	AOP	26.9	30.8	mgd	---	2	\$271,002	mgd	26.9	\$7,286,370					\$1,364,074
NCWRP AWPf COST SUBTOTAL										\$112,027,626	\$2,586,586	\$4,775,236	\$4,576,268	\$7,958,727	\$19,896,818
NCWRP TREATMENT COSTS										\$197,679,138	\$2,905,130	\$5,854,823	\$5,624,438	\$8,635,406	\$23,019,796
Harbor Drive															
Influent Pump Station	Influent Pump Station	55.4	110.7	mgd	---	2	\$0	mgd	55.4	\$0					
Preliminary	Conventional	55.4	110.7	mgd	---	2	\$941,678	mgd	55.4	\$52,141,174					
Primary	Conventional	55.4	110.7	mgd	---	2	\$584,473	mgd	55.4	\$32,362,564					
Secondary	MBR	55.4	110.7	mgd	---	2	\$4,238,373	mgd	55.4	\$234,680,902					
Tertiary															
Filtration	Provided by MF Below	0.0	0.0	mgd	---	3	\$0	mgd	0.0	N/A					
Disinfection	Chlorination (No NPR)	0.0	0.0	mgd	---	3	\$0	mgd	0.0	N/A					
Harbor Drive TERTIARY TREATMENT COST SUBTOTAL										\$319,184,640	\$1,395,937	\$8,375,624	\$2,559,218	\$10,934,842	\$23,265,621
AWPF	MF (MBR is Adequate)	0.0	0.0	mgd	---	3	\$0	mgd	0.0	N/A					\$0
	RO (Provided at Stadium)	0.0	0.0	mgd	---	3	\$0	mgd	0.0	N/A					\$0
	AOP (Provided at Stadium)	0.0	0.0	mgd	---	3	\$0	mgd	0.0	N/A					\$0
Harbor Drive AWPf COST SUBTOTAL										\$0	\$0	\$0	\$0	\$0	\$0
Harbor Drive TREATMENT COSTS										\$319,184,640	\$1,395,937	\$8,375,624	\$2,559,218	\$10,934,842	\$23,265,621
Stadium															
AWPF	MF (not required with MBR)	0.0	0.0	mgd	---	3	\$0	mgd	0.0	N/A					\$0
	RO	48.2	62.6	mgd	---	2	\$1,482,894	mgd	48.2	\$71,434,502					\$14,899,196
	AOP	40.9	53.2	mgd	---	2	\$264,702	mgd	40.9	\$10,838,606					\$1,824,183
STADIUM AWPf COST SUBTOTAL										\$82,273,109	\$2,174,039	\$4,013,611	\$3,846,377	\$6,689,352	\$16,723,379
STADIUM SPLIT FACILITY CONSTRUCTION ADDITIONAL COSTS										15%					\$12,340,966
STADIUM TREATMENT COSTS										\$94,614,075	\$2,174,039	\$4,013,611	\$3,846,377	\$6,689,352	\$16,723,379
TREATMENT COST SUBTOTAL										\$611,477,853	\$6,475,107	\$18,244,057	\$12,030,033	\$26,259,600	\$63,008,797
Waste Streams															
NC Brine (for Morena options)		6.1		mgd	20.0	1	\$436	LF	45,000	\$19,638,540					\$196,385
Stadium Brine		7.2		mgd	20.0	1	\$436	LF	42,700	\$18,634,732					\$186,348
WASTE STREAM COSTS										\$38,273,332					\$382,733
COLLECTIONS SYSTEMS IMPROVEMENTS															
Pump Stations															
Morena	PS to feed FM from Morena Blvd to NCWRP Headworks	1,633	1,960	hp		2	\$26,608	hp	1,960	\$52,149,622					\$2,585,403
Harbor Drive WRP Influent PS	PS to feed FM from PS2 to WRF Headworks	520	624	hp		2	\$26,608	hp	624	\$16,603,444					\$823,143
Pipeline															
Gravity															
Morena Gravity - PS feed	Diversion from Morena Blvd to MBPS	16.4	21.3	mgd	48.0	1	\$582	LF	1,000	\$581,934					\$5,819
Force Main															
Morena	Morena Blvd PS to NCWRP	16.4	21.3	mgd	42.0	1	\$453	LF	45,000	\$20,402,595					\$204,026
COLLECTION SYSTEM COST SUBTOTAL										\$89,737,595					\$3,618,391
NPR Distribution															
Pump Station - Harbor Drive to Stadium	only used in A1 and B1	1,164	1,396	hp	---	2	\$5,588	hp	1,396	\$7,802,924					\$1,108,233
Pipeline Segment 2 - Harbor Drive to Stadium	only used in A1 and B1	48.2	62.6	mgd	54.0	1	\$765	LF	42,700	\$32,678,199					\$326,782
NPR DISTRIBUTION SUBTOTAL										\$40,481,123					\$1,435,015
IPR Service															
Pump Station															
North City		4,141	4,970	hp	---	2	\$3,163	hp	4,970	\$15,717,441					\$3,642,719
Stadium	only used in A1 and B1	9,551	9,551	hp	---	2	\$1,866	hp	9,551	\$17,819,061					\$7,940,496
Harbor Drive	only used in A2 and B2	0	0	hp	---	2	\$1,866	hp	0	N/A					
Pipeline															
1 - NCWRP to Mission Gorge		26.9	26.9	mgd	42.0	1	\$649	LF	73,500	\$47,717,685					\$477,177
2 - Harbor Drive to Stadium	only used in A2 and B2	0.0	0.0	mgd	0.0	1	\$243	LF	0	N/A					
3 - Stadium to Mission Gorge		40.9	40.9	mgd	48.0	1	\$707	LF	49,700	\$35,150,762					\$351,508
4 - Mission Gorge to SVR		67.8	67.8	mgd	66.0	1	\$881	LF	48,500	\$42,746,668					\$427,467
5 - SVR Tunnel		67.8	67.8	mgd	66.0	1	\$881	LF	8,000	\$7,050,997					\$70,510
Tunneling									15,000	\$37,755,000					\$377,550
IPR SERVICE SUBTOTAL										\$203,957,614					\$13,287,426
SUBTOTAL										\$983,927,517					\$81,732,363
Soft Cost															
Contingency			% of Subtotal		40%					\$393,571,007					
EL&A			% of Subtotal		20%					\$196,785,503					
Environmental			% of Subtotal		20%					\$196,785,503					
Land Acquisition			% of Subtotal		4%					\$39,357,101					
Construction Management			% of Subtotal		10%					\$98,392,752					
SOFT COST SUBTOTAL										\$924,891,866					
TOTAL CAPITAL & O&M COSTS										\$1,908,819,382					\$81,732,363

SAN VICENTE - MODULE A1 FLOWS

North City	Up to tertiary	AWPF
		45.2 mgd required average capacity up to secondary at the North City WRP
		45.2 mgd installed average capacity up to secondary at the North City WRP
		44.6 mgd required average capacity of tertiary facilities at the North City WRP
		44.6 mgd installed average capacity of tertiary facilities at the North City WRP
		33.0 mgd required average capacity of AWPf at the North City WRP
		33.0 mgd installed average capacity of AWPf at the North City WRP
Pump Station 2 & Mission Valley	Up to tertiary	55.4 mgd required average capacity up to secondary at the Harbor Drive WRP
		55.4 mgd installed average capacity up to secondary at the Harbor Drive WRP
		52.4 mgd required average capacity of tertiary facilities at the Harbor Drive WRP
		52.4 mgd installed average capacity of tertiary facilities at the Harbor Drive WRP
	AWPF	0.0 mgd required average capacity of AWPf at the Harbor Drive WRP
	Option	0.0 mgd required average capacity of AWPf at the Harbor Drive WRP
		48.2 mgd required average capacity of AWPf at the Stadium WRP
		48.2 mgd installed average capacity of AWPf at the Stadium WRP

Notes
^a Some capacities indicate Incremental capacity installed if existing capacity is adequate. Otherwise, full capacity installed if complete replacement required.
^b Gravity sewer diameters determined using "Sewer-Slide Hydraulics Calculator"

Theme A2 - NC at 45 + Harbor Drive AWPf

Item	Description	Total Capacity		Unit	Pipe Diameter ^b	Construction Factor	CAPITAL COST				O&M				
		Average	Peak				Unit Cost	Unit	Quantity ^a	Cost	Chemical Cost	Energy Cost	Labor Cost	Other Cost	Total Annual Cost
TREATMENT UP TO AOP															
NCWRP Upgrades/Improvements															
Influent Pump Station	Upgrade existing influent PS	45.2	90.4	mgd	---	1	\$0	mgd	15.2	\$0					
Preliminary	Conventional	45.2	90.4	mgd	---	1	\$1,509,725	mgd	15.2	\$22,947,823					
Primary	Conventional	45.2	90.4	mgd	---	1	\$937,044	mgd	15.2	\$14,243,070					
Secondary	Conventional	45.2	90.4	mgd	---	1	\$3,188,199	mgd	15.2	\$48,460,618					
Tertiary															
Filtration	Provided by MF Below	0.0	0.0	mgd	---	3	\$0	mgd		N/A					
Disinfection	Chlorination (Existing Capacity Adequate)	0.0	0.0	mgd	---	3	\$0	mgd	0.0	N/A					
NCWRP TERTIARY TREATMENT COST SUBTOTAL										\$85,651,511	\$318,544	\$1,079,586	\$1,048,170	\$676,679	\$3,122,979
AWPF	MF (To replace existing granular filters)	44.6	58.0	mgd	---	4	\$1,225,021	mgd	44.6	\$54,686,539				\$7,067,857	
	RO (Includes 1.5 mgd permeate for blending)	33.0	42.9	mgd	---	2	\$1,518,190	mgd	33.0	\$50,054,717				\$11,464,887	
	AOP	26.9	30.8	mgd	---	2	\$271,002	mgd	26.9	\$7,286,370				\$1,364,074	
NCWRP AWPf COST SUBTOTAL										\$112,027,626	\$2,586,586	\$4,775,236	\$4,576,268	\$7,958,727	\$19,896,818
NCWRP TREATMENT COSTS										\$197,679,138	\$2,905,130	\$5,854,823	\$5,624,438	\$8,635,406	\$23,019,796
Harbor Drive															
Influent Pump Station	Influent Pump Station	55.4	110.7	mgd	---	2	\$0	mgd	55.4	\$0					
Preliminary	Conventional	55.4	110.7	mgd	---	2	\$941,678	mgd	55.4	\$52,141,174					
Primary	Conventional	55.4	110.7	mgd	---	2	\$584,473	mgd	55.4	\$32,362,564					
Secondary	MBR	55.4	110.7	mgd	---	2	\$4,238,373	mgd	55.4	\$234,680,902					
Tertiary															
Filtration	Provided by MBR	0.0	0.0	mgd	---	3	\$0	mgd	0.0	N/A					
Disinfection	Chlorination (No NPR)	0.0	0.0	mgd	---	3	\$0	mgd	0.0	N/A					
Harbor Drive TERTIARY TREATMENT COST SUBTOTAL										\$319,184,640	\$1,395,937	\$8,375,624	\$2,559,218	\$10,934,842	\$23,265,621
AWPF	MF (MBR is Adequate)	0.0	0.0	mgd	---	3	\$0	mgd	0.0	N/A				\$0	
	RO	48.2	62.6	mgd	---	2	\$1,420,436	mgd	48.2	\$68,425,735				\$14,899,196	
	AOP	40.9	53.2	mgd	---	2	\$253,553	mgd	40.9	\$10,382,093				\$1,824,183	
Harbor Drive AWPf COST SUBTOTAL										\$78,807,828	\$2,174,039	\$4,013,611	\$3,846,377	\$6,689,352	\$16,723,379
Harbor Drive TREATMENT COSTS SUBTOTAL										\$397,992,468	\$3,569,977	\$12,389,235	\$6,405,596	\$17,624,194	\$39,989,001
Harbor Drive DIFFICULT CONSTRUCTION ADDITIONAL COSTS										\$43,089,926					
Harbor Drive TREATMENT COST										\$441,082,394					
Stadium															
AWPF	MF (not required with MBR)	0.0	0.0	mgd	---	3	\$0	mgd	0.0	N/A				\$0	
	RO (provided at Harbor Drive)	0.0	0.0	mgd	---	3	\$0	mgd	0.0	N/A				\$0	
	AOP (provided at Harbor Drive)	0.0	0.0	mgd	---	3	\$0	mgd	0.0	N/A				\$0	
STADIUM AWPf COST SUBTOTAL										\$0	\$0	\$0	\$0	\$0	\$0
STADIUM TREATMENT COSTS										\$0	\$0	\$0	\$0	\$0	\$0
TREATMENT COST SUBTOTAL										\$638,761,532	\$6,475,107	\$18,244,057	\$12,030,033	\$26,259,600	\$63,008,797
Waste Streams															
	NC Brine (for Morena options)	6.1		mgd	20.0	1	\$436	LF	45,000	\$19,638,540				\$196,385	
	Stadium Brine	0.0		mgd	0.0	1	\$243	LF	0	N/A					
WASTE STREAM COSTS										\$19,638,540					\$196,385
COLLECTIONS SYSTEMS IMPROVEMENTS															
Pump Stations															
Morena	PS to feed FM from Morena Blvd to NCWRP Headworks	1,633	1,960	hp		2	\$26,608	hp	1,960	\$52,149,622				\$2,585,403	
Harbor Drive WRP Influent PS	PS to feed FM from PS2 to AWPf Headworks	520	624	hp		2	\$26,608	hp	624	\$16,603,444				\$823,143	
Pipeline															
Gravity															
Morena Gravity - PS feed	Diversion from Morena Blvd to MBPS	16.4	21.3	mgd	48.0	1	\$582	LF	1,000	\$581,934				\$5,819	
Force Main															
Morena	Morena Blvd PS to NCWRP	16.4	21.3	mgd	42.0	1	\$453	LF	45,000	\$20,402,595				\$204,026	
COLLECTION SYSTEM COST SUBTOTAL										\$89,737,595					\$3,618,391
NPR Distribution															
Pump Station - Harbor Drive to Stadium	only used in A1 and B1		0	hp	---	2	\$1,866	hp	0	N/A					
Pipeline Segment 2 - Harbor Drive to Stadium	only used in A1 and B1		0	mgd	0.0	1	\$243	LF	0	N/A					
NPR DISTRIBUTION SUBTOTAL										\$0					\$0
IPR Service															
Pump Station															
North City		4,141	4,970	hp	---	2	\$3,163	hp	4,970	\$15,717,441				\$3,642,719	
Stadium	only used in A1 and B1	0	0	hp	---	2	\$1,866	hp	0	N/A					
Harbor Drive	only used in A2 and B2	10,709	12,851	hp	---	2	\$1,866	hp	12,851	\$23,974,848				\$9,002,917	
Pipeline															
1 - NCWRP to Mission Gorge		26.9	26.9	mgd	42.0	1	\$649	LF	73,500	\$47,717,685				\$477,177	
2 - Harbor Drive to Stadium		48.2	48.2	mgd	54.0	1	\$765	LF	42,700	\$32,678,199				\$326,782	
3 - Stadium to Mission Gorge	only used in A2 and B2	40.9	40.9	mgd	48.0	1	\$707	LF	49,700	\$35,150,762				\$351,508	
4 - Mission Gorge to SVR		67.8	67.8	mgd	66.0	1	\$881	LF	48,500	\$42,746,668				\$427,467	
5 - SVR Tunnel		67.8	67.8	mgd	66.0	1	\$881	LF	8,000	\$7,050,997				\$70,510	
Tunneling							\$2,517	LF	15,000	\$37,755,000				\$377,550	
IPR SERVICE SUBTOTAL										\$242,791,600					\$14,676,629
SUBTOTAL										\$990,929,266					\$81,500,202
Soft Cost															
Contingency			% of Subtotal		40%					\$396,371,707					
EL&A			% of Subtotal		20%					\$198,185,853					
Environmental			% of Subtotal		20%					\$198,185,853					
Land Acquisition			% of Subtotal		4%					\$39,637,171					
Construction Management			% of Subtotal		10%					\$99,092,927					
SOFT COST SUBTOTAL										\$931,473,510					
TOTAL CAPITAL & O&M COSTS										\$1,922,402,777					\$81,500,202

SAN VICENTE - MODULE A2 FLOWS

Location	Flow Type	Capacity	Status	Description
North City	Up to tertiary	45.2 mgd	required	average capacity up to secondary at the North City WRP
		45.2 mgd	installed	average capacity up to secondary at the North City WRP
	44.6 mgd	required	average capacity of tertiary facilities at the North City WRP	
	44.6 mgd	installed	average capacity of tertiary facilities at the North City WRP	
Pump Station 2 & Mission Valley	Up to tertiary	33.0 mgd	required	average capacity of AWPf at the North City WRP
		33.0 mgd	installed	average capacity of AWPf at the North City WRP
	55.4 mgd	required	average capacity up to secondary at the Harbor Drive WRP	
	55.4 mgd	installed	average capacity up to secondary at the Harbor Drive WRP	
AWPF Option	AWPF	52.4 mgd	required	average capacity of tertiary facilities at the Harbor Drive WRP
		52.4 mgd	installed	average capacity of tertiary facilities at the Harbor Drive WRP
	48.2 mgd	required	average capacity of AWPf at the Harbor Drive WRP	
	48.2 mgd	installed	average capacity of AWPf at the Harbor Drive WRP	
AWPF Option	AWPF	0.0 mgd	required	average capacity of AWPf at the Stadium WRP
		0.0 mgd	installed	average capacity of AWPf at the Stadium WRP

Notes
a Some capacities indicate Incremental capacity installed if existing capacity is adequate. Otherwise, full capacity installed if complete replacement required.
b Gravity sewer diameters determined using "Sewer-Slide Hydraulics Calculator"

Theme B1 - NC at 30 + Harbor Drive Tertiary + Stadium AWPf

Item	Description	Total Capacity		Unit	Pipe Diameter ^b	Construction Factor	CAPITAL COST				O&M				Total Annual Cost	
		Average	Peak				Unit Cost	Unit	Quantity ^a	Cost	Chemical Cost	Energy Cost	Labor Cost	Other Cost		
TREATMENT UP TO AOP																
NCWRP Upgrades/Improvements																
Influent Pump Station	Upgrade existing influent PS	30.0	60.0	mgd	---	1	\$0	mgd	0.0							
Preliminary	Conventional	30.0	60.0	mgd	---	1	\$1,740,243	mgd	0.0							
Primary	Conventional	30.0	60.0	mgd	---	1	\$1,080,120	mgd	0.0							
Secondary	Conventional	30.0	60.0	mgd	---	1	\$3,675,000	mgd	0.0							
Tertiary																
Filtration	Provided by MF Below	0.0	0.0	mgd	---	3	\$0	mgd								
Disinfection	Chlorination (Existing Capacity Adequate)	0.0	0.0	mgd	---	3	\$0	mgd	0.0							
NCWRP TERTIARY TREATMENT COST SUBTOTAL							\$0				\$0	\$0	\$0	\$0	\$0	
AWPF	MF (To replace existing granular filters)	29.3	38.1	mgd	---	4	\$1,395,660	mgd	29.3						\$5,280,019	
	RO (Includes 1.5 mgd permeate for blending)	18.8	24.5	mgd	---	2	\$1,729,666	mgd	18.8						\$7,785,225	
	AOP	15.0	18.9	mgd	---	2	\$308,751	mgd	15.0						\$911,185	
NCWRP AWPf COST SUBTOTAL											\$78,052,737	\$1,816,936	\$3,354,343	\$3,214,579	\$5,590,571	\$13,976,428
NCWRP TREATMENT COSTS											\$78,052,737	\$1,816,936	\$3,354,343	\$3,214,579	\$5,590,571	\$13,976,428
Harbor Drive																
Influent Pump Station	Influent Pump Station	71.5	142.9	mgd	---	2	\$0	mgd	71.5						\$0	
Preliminary	Conventional	71.5	142.9	mgd	---	2	\$870,293	mgd	71.5						\$62,193,248	
Primary	Conventional	71.5	142.9	mgd	---	2	\$540,166	mgd	71.5						\$38,601,604	
Secondary	MBR	71.5	142.9	mgd	---	2	\$3,917,078	mgd	71.5						\$279,924,027	
Tertiary																
Filtration	Provided by MBR	0.0	0.0	mgd	---	3	\$0	mgd	0.0						N/A	
Disinfection	Chlorination (No NPR)	0.0	0.0	mgd	---	3	\$0	mgd	0.0						N/A	
Harbor Drive TERTIARY TREATMENT COST SUBTOTAL							\$380,718,878				\$1,659,117	\$9,954,705	\$3,041,715	\$12,996,420	\$27,651,958	
AWPF	MF (MBR is Adequate)	0.0	0.0	mgd	---	3	\$0	mgd	0.0						\$0	
	RO	0.0	0.0	mgd	---	2	\$1,750,000	mgd	0.0						\$0	
	AOP	0.0	0.0	mgd	---	2	\$312,381	mgd	0.0						\$0	
Harbor Drive AWPf COST SUBTOTAL							\$0				\$0	\$0	\$0	\$0	\$0	
Harbor Drive TREATMENT COSTS							\$380,718,878				\$1,659,117	\$9,954,705	\$3,041,715	\$12,996,420	\$27,651,958	
Stadium																
AWPF	MF (not required with MBR)	0.0	0.0	mgd	---	3	\$0	mgd	0.0						\$0	
	RO	62.2	80.8	mgd	---	2	\$1,370,482	mgd	62.2						\$17,771,548	
	AOP	52.8	68.7	mgd	---	2	\$244,636	mgd	52.8						\$12,928,135	
STADIUM AWPf COST SUBTOTAL							\$98,134,189				\$2,593,163	\$4,787,378	\$4,587,904	\$7,978,963	\$19,947,408	
STADIUM SPLIT FACILITY CONSTRUCTION ADDITIONAL COSTS															15%	\$14,720,128
STADIUM TREATMENT COSTS							\$112,854,317				\$2,593,163	\$4,787,378	\$4,587,904	\$7,978,963	\$19,947,408	
TREATMENT COST SUBTOTAL							\$571,625,932				\$6,069,216	\$18,096,426	\$10,844,198	\$26,565,955	\$61,575,794	
Waste Streams																
NC Brine (for Morena options)		0.0		mgd	0.0	1	\$243	LF	0						N/A	
Stadium Brine		9.3		mgd	24.0	1	\$475	LF	42,700						\$202,870	
WASTE STREAM COSTS															\$202,870	
COLLECTIONS SYSTEMS IMPROVEMENTS																
Pump Stations																
Morena	PS to feed FM from Morena Blvd to NCWRP Headworks	0	0	hp		2	\$26,608	hp	0						N/A	
Harbor Drive WRP Influent PS	PS to feed FM from PS2 to AWPf Headworks	671	806	hp		2	\$26,608	hp	806						\$21,439,174	
Pipeline																
Gravity																
Morena Gravity - PS feed	Diversion from Morena Blvd to MBPS	0.0	0.0	mgd		1	\$70	LF	0						N/A	
Force Main																
Morena	Morena Blvd PS to NCWRP	0.0	0.0	mgd		1	\$0	LF	45,000						\$0	
COLLECTION SYSTEM COST SUBTOTAL							\$21,439,174								\$1,062,882	
NPR Distribution																
Pump Station - Harbor Drive to Stadium	only used in A1 and B1	1,469	1,763	hp	---	2	\$5,588	hp	1,763						\$9,852,200	
Pipeline Segment 2 - Harbor Drive to Stadium	only used in A1 and B1	62.2		mgd	60.0	1	\$823	LF	42,700						\$35,156,447	
NPR DISTRIBUTION SUBTOTAL							\$45,008,647								\$1,750,852	
IPR Service																
Pump Station																
North City		2,602	3,122	hp	---	2	\$3,163	hp	3,122						\$9,874,763	
Stadium	only used in A1 and B1	11,840	14,208	hp	---	2	\$1,866	hp	14,208						\$26,506,636	
Harbor Drive	only used in A2 and B2	0	0	hp	---	2	\$1,866	hp	0						N/A	
Pipeline																
1 - NCWRP to Mission Gorge		15.0	15.0	mgd	30.0	1	\$533	LF	73,500						\$39,186,011	
2 - Harbor Drive to Stadium		0.0	0.0	mgd	0.0	1	\$243	LF							N/A	
3 - Stadium to Mission Gorge	only used in A2 and B2	52.8	52.8	mgd	60.0	1	\$823	LF	49,700						\$409,199	
4 - Mission Gorge to SVR		67.8	67.8	mgd	66.0	1	\$881	LF	48,500						\$427,467	
5 - SVR Tunnel		67.8	67.8	mgd	66.0	1	\$881	LF	8,000						\$70,510	
Tunneling							\$2,517	LF	15,000						\$37,550,000	
IPR SERVICE SUBTOTAL							\$204,039,874								\$13,918,830	
SUBTOTAL							\$862,400,585									\$78,511,228
Soft Cost																
Contingency			% of Subtotal		40%										\$344,960,234	
EL&A			% of Subtotal		20%										\$172,480,117	
Environmental			% of Subtotal		20%										\$172,480,117	
Land Acquisition			% of Subtotal		4%										\$34,496,023	
Construction Management			% of Subtotal		10%										\$86,240,058	
SOFT COST SUBTOTAL															\$810,656,550	
TOTAL CAPITAL & O&M COSTS											\$1,673,057,135					\$78,511,228

SAN VICENTE - MODULE B1 FLOWS		
North City	Up to tertiary	28.8 mgd required average capacity up to secondary at the North City WRP 30.0 mgd installed average capacity up to secondary at the North City WRP
	AWPF	29.3 mgd required average capacity of tertiary facilities at the North City WRP 29.3 mgd installed average capacity of tertiary facilities at the North City WRP 18.8 mgd required average capacity of AWPf at the North City WRP 18.8 mgd installed average capacity of AWPf at the North City WRP
Pump Station 2 & Mission Valley	Up to tertiary	71.5 mgd required average capacity up to secondary at the Harbor Drive WRP 71.5 mgd installed average capacity up to secondary at the Harbor Drive WRP
	AWPF Option	67.6 mgd required average capacity of tertiary facilities at the Harbor Drive WRP 67.6 mgd installed average capacity of tertiary facilities at the Harbor Drive WRP 0.0 mgd required average capacity of AWPf at the Harbor Drive WRP 0.0 mgd installed average capacity of AWPf at the Harbor Drive WRP 62.2 mgd required average capacity of AWPf at the Stadium WRP 62.2 mgd installed average capacity of AWPf at the Stadium WRP

Notes
^a Some capacities indicate Incremental capacity installed if existing capacity is adequate. Otherwise, full capacity installed if complete replacement required.
^b Gravity sewer diameters determined using "Sewer-Slide Hydraulics Calculator"

Theme B2 - NC at 30 + Harbor Drive WRP/AWPF

Item	Description	Total Capacity			Pipe Diameter ^b	Construction Factor	CAPITAL COST				O&M				Total Annual Cost	
		Average	Peak	Unit			Unit Cost	Unit	Quantity ^a	Cost	Chemical Cost	Energy Cost	Labor Cost	Other Cost		
TREATMENT UP TO AOP																
NCWRP Upgrades/Improvements																
Influent Pump Station	Upgrade existing influent PS	30.0	60.0	mgd	---	1	\$0	mgd	0.0	N/A						
Preliminary	Conventional	30.0	60.0	mgd	---	1	\$1,740,243	mgd	0.0	N/A						
Primary	Conventional	30.0	60.0	mgd	---	1	\$1,080,120	mgd	0.0	N/A						
Secondary	Conventional	30.0	60.0	mgd	---	1	\$3,675,000	mgd	0.0	N/A						
Tertiary																
Filtration	Provided by MF Below	0.0	0.0	mgd	---	3	\$0	mgd		N/A						
Disinfection	Chlorination (Existing Capacity Adequate)	0.0	0.0	mgd	---	3	\$0	mgd	0.0	N/A						
NCWRP TERTIARY TREATMENT COST SUBTOTAL							\$0				\$0	\$0	\$0	\$0	\$0	
AWPF	MF (To replace existing granular filters)	29.3	38.1	mgd	---	4	\$1,395,660	mgd	29.3	\$40,853,399					\$5,280,019	
	RO (Includes 1.5 mgd permeate for blending)	18.8	24.5	mgd	---	2	\$1,729,666	mgd	18.8	\$32,569,605					\$7,785,225	
	AOP	15.0	18.9	mgd	---	2	\$308,751	mgd	15.0	\$4,629,734					\$911,185	
NCWRP AWPF COST SUBTOTAL											\$78,052,737	\$1,816,936	\$3,354,343	\$3,214,579	\$5,590,571	\$13,976,428
NCWRP TREATMENT COSTS											\$78,052,737	\$1,816,936	\$3,354,343	\$3,214,579	\$5,590,571	\$13,976,428
Harbor Drive																
Influent Pump Station	Influent Pump Station	71.5	142.9	mgd	---	2	\$0	mgd	71.5	\$0						
Preliminary	Conventional	71.5	142.9	mgd	---	2	\$870,293	mgd	71.5	\$62,193,248						
Primary	Conventional	71.5	142.9	mgd	---	2	\$540,166	mgd	71.5	\$38,601,604						
Secondary	MBR	71.5	142.9	mgd	---	2	\$3,917,078	mgd	71.5	\$279,924,027						
Tertiary																
Filtration	Provided by MBR	0.0	0.0	mgd	---	3	\$0	mgd	0.0	N/A						
Disinfection	Chlorination (No NPR)	0.0	0.0	mgd	---	3	\$0	mgd	0.0	N/A						
Harbor Drive TERTIARY TREATMENT COST SUBTOTAL							\$380,718,878				\$1,659,117	\$9,954,705	\$3,041,715	\$12,996,420	\$27,651,958	
AWPF	MF (MBR is Adequate)	0.0	0.0	mgd	---	3	\$0	mgd	0.0	N/A					\$0	
	RO	62.2	80.8	mgd	---	2	\$1,312,758	mgd	62.2	\$81,617,239					\$17,771,548	
	AOP	52.8	68.7	mgd	---	2	\$234,332	mgd	52.8	\$12,383,612					\$2,175,860	
Harbor Drive AWPF COST SUBTOTAL											\$94,000,851	\$2,593,163	\$4,787,378	\$4,587,904	\$7,978,963	\$19,947,408
Harbor Drive TREATMENT COSTS SUBTOTAL							\$474,719,729				\$4,252,281	\$14,742,083	\$7,629,619	\$20,975,383	\$47,599,366	
Harbor Drive DIFFICULT CONSTRUCTION ADDITIONAL COSTS							\$51,397,049									
Harbor Drive TREATMENT COST							\$526,116,778									
Stadium																
AWPF	MF (not required with MBR)	0.0	0.0	mgd	---	3	\$0	mgd	0.0	N/A					\$0	
	RO	0.0	0.0	mgd	---	3	\$0	mgd	0.0	N/A					\$0	
	AOP	0.0	0.0	mgd	---	3	\$0	mgd	0.0	N/A					\$0	
STADIUM AWPF COST SUBTOTAL							\$0				\$0	\$0	\$0	\$0	\$0	
STADIUM TREATMENT COSTS							\$0				\$0	\$0	\$0	\$0	\$0	
TREATMENT COST SUBTOTAL							\$604,169,515				\$6,069,216	\$18,096,426	\$10,844,198	\$26,565,955	\$61,575,794	
Waste Streams																
	NC Brine (for Morena options)	0.0		mgd	0.0	1	\$243	LF	0	N/A						
	Stadium Brine	0.0		mgd	0.0	1	\$243	LF	0	N/A						
WASTE STREAM COSTS							\$0								\$0	
COLLECTIONS SYSTEMS IMPROVEMENTS																
Pump Stations																
Morena	PS to feed FM from Morena Blvd to NCWRP Headworks	0	0	hp		2	\$26,608	hp	0	N/A						
Harbor Drive WRP Influent PS	PS to feed FM from PS2 to AWPF Headworks	671	806	hp		2	\$26,608	hp	806	\$21,439,174					\$1,062,882	
Pipeline																
Gravity																
Morena Gravity - PS feed	Diversion from Morena Blvd to MBPS	0.0	0.0	mgd	0.0	1	\$70	LF	0	N/A						
Force Main																
Morena	Morena Blvd PS to NCWRP	0.0	0.0	mgd		1	\$0	LF	45,000	\$0					\$0	
COLLECTION SYSTEM COST SUBTOTAL							\$21,439,174								\$1,062,882	
NPR Distribution																
Pump Station - Harbor Drive to Stadium	only used in A1 and B1		0	hp	---	2	\$1,866	hp	0	N/A						
Pipeline Segment 2 - Harbor Drive to Stadium	only used in A1 and B1			mgd	0.0	1	\$0	LF	42,700	\$0					\$0	
NPR DISTRIBUTION SUBTOTAL							\$0								\$0	
IPR Service																
Pump Station																
North City		2,602	3,122	hp	---	2	\$3,163	hp	3,122	\$9,874,763					\$2,288,603	
Stadium	only used in A1 and B1	0	0	hp	---	2	\$1,866	hp	0	N/A						
Harbor Drive	only used in A2 and B2	12,916	15,499	hp	---	2	\$1,866	hp	15,499	\$28,914,625					\$10,857,878	
Pipeline																
1 - NCWRP to Mission Gorge		15.0	15.0	mgd	30.0	1	\$533	LF	73,500	\$39,186,011					\$391,860	
2 - Harbor Drive to Stadium		52.8	52.8	mgd	60.0	1	\$823	LF	42,700	\$35,156,447					\$351,564	
3 - Stadium to Mission Gorge	only used in A2 and B2	52.8	52.8	mgd	60.0	1	\$823	LF	49,700	\$40,919,799					\$409,198	
4 - Mission Gorge to SVR		67.8	67.8	mgd	66.0	1	\$881	LF	48,500	\$42,746,668					\$427,467	
5 - SVR Tunnel		67.8	67.8	mgd	66.0	1	\$881	LF	8,000	\$7,050,997					\$70,510	
Tunneling							\$2,517	LF	15,000	\$37,755,000					\$377,550	
IPR SERVICE SUBTOTAL							\$241,604,311								\$15,174,631	
SUBTOTAL							\$867,212,999									\$77,813,307
Soft Cost																
Contingency			% of Subtotal		40%					\$346,885,200						
EL&A			% of Subtotal		20%					\$173,442,600						
Environmental			% of Subtotal		20%					\$173,442,600						
Land Acquisition			% of Subtotal		4%					\$34,688,520						
Construction Management			% of Subtotal		10%					\$86,721,300						
SOFT COST SUBTOTAL							\$815,180,219									
TOTAL CAPITAL & O&M COSTS							\$1,682,393,218									\$77,813,307

SAN VICENTE - MODULE B2 FLOWS		
North City	Up to tertiary	28.8 mgd required average capacity up to secondary at the North City WRP 30.0 mgd installed average capacity up to secondary at the North City WRP 29.3 mgd required average capacity of tertiary facilities at the North City WRP 29.3 mgd installed average capacity of tertiary facilities at the North City WRP 18.8 mgd required average capacity of AWPF at the North City WRP 18.8 mgd installed average capacity of AWPF at the North City WRP
	AWPF	
Pump Station 2 & Mission Valley	Up to tertiary	71.5 mgd required average capacity up to secondary at the Harbor Drive WRP 71.5 mgd installed average capacity up to secondary at the Harbor Drive WRP 67.6 mgd required average capacity of tertiary facilities at the Harbor Drive WRP 67.6 mgd installed average capacity of tertiary facilities at the Harbor Drive WRP
	AWPF	62.2 mgd required average capacity of AWPF at the Harbor Drive WRP 62.2 mgd installed average capacity of AWPF at the Harbor Drive WRP
	Option	0.0 mgd required average capacity of AWPF at the Stadium WRP 0.0 mgd installed average capacity of AWPF at the Stadium WRP

Notes
a Some capacities indicate Incremental capacity installed if existing capacity is adequate. Otherwise, full capacity installed if complete replacement required.
b Gravity sewer diameters determined using "Sewer-Slide Hydraulics Calculator"

Theme B3 - NC at 30 + Mission Gorge + Harbor Drive AWP

Item	Description	Total Capacity		Unit	Pipe Diameter ^b	Construction Factor	CAPITAL COST			O&M				Total Annual Cost	
		Average	Peak				Unit Cost	Unit	Quantity ^a	Cost	Chemical Cost	Energy Cost	Labor Cost		Other Cost
TREATMENT UP TO AOP															
NCWRP Upgrades/Improvements															
Influent Pump Station	Upgrade existing influent PS	30.0	60.0	mgd	---	1	see collection syst	mgd	0.0	-					
Preliminary	Conventional	30.0	60.0	mgd	---	1	\$1,740,243	mgd	0.0	N/A					
Primary	Conventional	30.0	60.0	mgd	---	1	\$1,080,120	mgd	0.0	N/A					
Secondary	Conventional	30.0	60.0	mgd	---	1	\$3,675,000	mgd	0.0	N/A					
Tertiary	Provided by MF Below	0.0	0.0	mgd	---	3	\$0	mgd	0.0	N/A					
Filtration	Chlorination (Existing Capacity Adequate)	0.0	0.0	mgd	---	3	\$0	mgd	0.0	N/A					
Disinfection															
NCWRP TERTIARY TREATMENT COST SUBTOTAL															
AWPF	MF (To replace existing granular filters)	29.3	38.1	mgd	---	4	\$1,395,660	mgd	29.3	\$40,853,399					\$5,280,019
	RO (Includes 1.5 mgd permeate for blending)	18.8	24.5	mgd	---	2	\$1,729,666	mgd	18.8	\$32,569,605					\$7,785,225
	AOP	15.0	18.9	mgd	---	2	\$308,751	mgd	15.0	\$4,629,734					\$911,185
NCWRP AWP COST SUBTOTAL															
NCWRP TREATMENT COSTS															
Mission Gorge Upgrades/Improvements															
Influent Pump Station	Upgrade existing influent PS	9.1	18.2	mgd	---	2	see collection syst	mgd	9.1	-					
Preliminary	Conventional	9.1	18.2	mgd	---	2	\$1,644,242	mgd	9.1	\$14,992,269					
Primary	Conventional	9.1	18.2	mgd	---	2	\$1,020,535	mgd	9.1	\$9,305,280					
Secondary	MBR	9.1	18.2	mgd	---	2	\$7,400,528	mgd	9.1	\$67,478,325					
Tertiary	Provided by MBR	0.0	0.0	mgd	---	2	\$1,086,206	mgd	0.0	N/A					
Filtration	Chlorination	0.0	0.0	mgd	---	2	\$19,352	mgd	0.0	N/A					
Disinfection															
Mission Gorge TERTIARY TREATMENT COST SUBTOTAL															
AWPF	MF (Not Needed - Provided by MBR)	8.0	10.4	mgd	---	3	\$0	mgd	0.0	N/A					\$0
	RO (assumed no blending w/ NPR needed)	8.0	10.4	mgd	---	2	\$2,480,191	mgd	8.0	\$19,778,773					\$4,299,660
	AOP	6.8	8.8	mgd	---	2	\$442,723	mgd	6.8	\$3,000,992					\$526,429
Mission Gorge AWP COST SUBTOTAL															
Mission Gorge TREATMENT COSTS															
Harbor Drive															
Influent Pump Station	Influent Pump Station	62.2	124.4	mgd	---	2	see collection syst	mgd	62.2	-					
Preliminary	Conventional	62.2	124.4	mgd	---	2	\$908,417	mgd	62.2	\$56,507,322					
Primary	Conventional	62.2	124.4	mgd	---	2	\$563,929	mgd	62.2	\$35,072,509					
Secondary	MBR	62.2	124.4	mgd	---	2	\$4,088,670	mgd	62.2	\$254,332,387					
Tertiary	Provided by MBR	54.1	70.4	mgd	---	3	\$0	mgd	0.0	N/A					
Filtration	Chlorination (No NPR)	0.0	0.0	mgd	---	3	\$0	mgd	0.0	N/A					
Disinfection															
Harbor Drive TERTIARY TREATMENT COST SUBTOTAL															
AWPF	MF (MBR is Adequate)	54.1	70.4	mgd	---	3	\$0	mgd	0.0	N/A					\$0
	RO	54.1	70.4	mgd	---	2	\$1,370,265	mgd	54.1	\$74,155,504					\$16,146,811
	AOP	46.0	59.8	mgd	---	2	\$244,597	mgd	46.0	\$11,251,458					\$1,976,935
Harbor Drive AWP COST SUBTOTAL															
Harbor Drive TREATMENT COSTS															
Harbor Drive DIFFICULT CONSTRUCTION ADDITIONAL COSTS															
Harbor Drive TREATMENT COST															
Stadium															
AWPF	MF (not required with MBR)	0.0	0.0	mgd	---	3	\$0	mgd	0.0	N/A					\$0
	RO	0.0	0.0	mgd	---	1	\$2,625,000	mgd	0.0	N/A					\$0
	AOP	0.0	0.0	mgd	---	1	\$468,571	mgd	0.0	N/A					\$0
STADIUM AWP COST SUBTOTAL															
STADIUM TREATMENT COSTS															
TREATMENT COST SUBTOTAL															
Waste Streams															
NC Brine (for Morena options)		0.0		mgd	0.0	1	\$243	LF	0	N/A					
Mission Gorge Brine (to PS2) and Solids (assume no brine line)		0.0		mgd	0.0	1	\$243	LF	0	N/A					
				mgd	0.0	1	\$243	LF	0	N/A					
				hp	0.0	2	N/A	HP	0	N/A					
WASTE STREAM COSTS															
COLLECTIONS SYSTEMS IMPROVEMENTS															
Pump Stations															
Mission Gorge	PS to feed FM from EMGPS to Headworks	423	508	hp		1	\$39,912	hp	508	\$20,273,676					\$839,014
Harbor Drive WRP Influent PS	PS to feed FM from PS2 to AWP Headworks	585	702	hp		1	\$39,912	hp	702	\$28,006,532					\$1,159,034
Pipeline															
Gravity	Already gravity flow	0.0	0.0	mgd		1	\$70	LF	0	N/A					
Mission Gorge		9.1	11.9	mgd	30.0	1	\$342	LF	11,000	\$3,760,493					\$37,605
Force Main															
Mission Gorge															
COLLECTION SYSTEM COST SUBTOTAL															
NPR Distribution															
Pump Station - Harbor Drive to Mission Gorge				hp	---	2	N/A	hp	0	N/A					
Pipeline Segment 2 - Harbor Drive to Mission Gorge				mgd	0.0	1	\$243	LF		N/A					
NPR DISTRIBUTION SUBTOTAL															
IPR Service															
Pump Station															
North City		2,602	3,122	hp	---	2	\$3,163	hp	3,122	\$9,873,460					\$2,288,301
Mission Gorge		643	772	hp	---	2	\$6,056	hp	772	\$4,672,884					\$621,364
Harbor Drive		11,513	13,815	hp	---	2	\$1,866	hp	13,815	\$25,774,002					\$9,678,527
Pipeline															
1 - NCWRP to Mission Gorge		15.0	15.0	mgd	30.0	1	\$533	LF	73,500	\$39,186,011					\$391,860
2 - Harbor Drive to Stadium		46.0	46.0	mgd	54.0	1	\$765	LF	42,700	\$32,678,199					\$326,782
3 - Stadium to Mission Gorge		46.0	46.0	mgd	54.0	1	\$765	LF	49,700	\$38,035,281					\$380,353
4 - Mission Gorge to SVR		67.8	67.8	mgd	66.0	1	\$881	LF	48,500	\$42,746,688					\$427,467
5 - SVR Tunnel		67.8	67.8	mgd	66.0	1	\$881	LF	8,000	\$7,050,997					\$70,510
Mission Gorge Plant to segment		6.8	6.8	mgd	20.0	2	\$202	LF	11,000	\$2,225,124					\$22,251
Tunneling															
IPR SERVICE SUBTOTAL															
SUBTOTAL															
Soft Cost															
Contingency			% of Subtotal		40%					\$387,079,213					
EL&A			% of Subtotal		20%					\$193,539,606					
Interagency coordination and agreements (Mission Gorge only)										\$1,000,000					\$100,000
Environmental			% of Subtotal		20%					\$193,539,606					
Land Acquisition			% of Subtotal		4%					\$38,707,921					
Construction Management			% of Subtotal		10%					\$96,769,803					
SOFT COST SUBTOTAL															
TOTAL CAPITAL & O&M COSTS															
\$1,878,334,182															
\$85,730,690															

SAN VICENTE - MODULE B3 FLOWS			
Location	Flow Type	Capacity (mgd)	Description
North City	Up to tertiary	28.8	28.8 mgd required average capacity up to secondary at the North City WRP
	AWPF	30.0	30.0 mgd installed average capacity up to secondary at the North City WRP
	AWPF	29.3	29.3 mgd required average capacity of tertiary facilities at the North City WRP
Mission Gorge	Up to tertiary	9.1	9.1 mgd required average capacity up to secondary at the Mission Gorge WRP
	AWPF	9.1	9.1 mgd installed average capacity up to secondary at the Mission Gorge WRP
	AWPF	8.7	8.7 mgd required average capacity of tertiary facilities at the Mission Gorge WRP
Pump Station 2 & Mission Valley	Up to tertiary	62.2	62.2 mgd required average capacity up to secondary at the Harbor Drive WRP
	AWPF	62.2	62.2 mgd installed average capacity up to secondary at the Harbor Drive WRP
	AWPF Option	58.8	58.8 mgd required average capacity of tertiary facilities at the Harbor Drive WRP
Stadium	Up to tertiary	54.1	54.1 mgd required average capacity of AWP at the Harbor Drive WRP
	AWPF	54.1	54.1 mgd installed average capacity of AWP at the Harbor Drive WRP
	AWPF	0.0	0.0 mgd required average capacity of AWP at the Stadium WRP
Stadium	Up to tertiary	0.0	0.0 mgd installed average capacity of AWP at the Stadium WRP
	AWPF	0.0	0.0 mgd required average capacity of AWP at the Stadium WRP
	AWPF	0.0	0.0 mgd installed average capacity of AWP at the Stadium WRP

Notes
 a Some capacities indicate incremental capacity installed if existing capacity is adequate. Otherwise, full capacity installed if complete replacement required.
 b Gravity sewer diameters determined using "Sewer-Slide Hydraulics Calculator"

C2 = SV8 Diversion + Additional Non-potable Reuse + Otay Lakes

Item	Description	Total Capacity		Unit	Pipe Diameter ^b	Construction Factor	CAPITAL COST				O&M				Total Annual Cost
		Average	Peak				Unit Cost	Unit	Quantity ^a	Cost	Chemical Cost	Energy Cost	Labor Cost	Other Cost	
TREATMENT UP TO AOP															
South Bay WRP Upgrades/Improvements															
Influent Pump Station	Upgrade existing influent PS (GAPS)	44.0	88.0	mgd	---	1	\$0	mgd	26.0	\$0					
Preliminary	Conventional (Upsize after WWMP Upgrades)	44.0	88.0	mgd	---	1	\$1,485,896	mgd	26.0	\$38,633,296					
Primary	Conventional (Upsize after WWMP Upgrades)	44.0	88.0	mgd	---	1	\$922,254	mgd	26.0	\$23,978,604					
Secondary	Conventional (Upsize after WWMP Upgrades)	44.0	88.0	mgd	---	1	\$3,137,876	mgd	26.0	\$81,584,776					
Tertiary															
Filtration	Granular	0.0	0.0	mgd	---	3	\$0	mgd	0.0	N/A					
Disinfection	UV	26.7	34.7	mgd	---	1	\$238,260	mgd	11.7	\$2,782,365					
SBWRP TERTIARY TREATMENT COST SUBTOTAL										\$146,979,041	\$586,006	\$1,986,052	\$1,928,257	\$1,244,847	\$5,745,162
AWPF															
	MF	29.0	37.7	mgd	---	2	\$1,076,710	mgd	29.0	\$31,222,069					\$5,245,808
	RO	17.7	23.0	mgd	---	2	\$1,734,701	mgd	17.7	\$30,648,427					\$7,449,951
	AOP	15.0	18.3	mgd	---	2	\$309,650	mgd	15.0	\$4,644,750					\$911,393
SBWRP AWPf TREATMENT COSTS										\$66,515,246	\$1,387,929	\$4,703,873	\$4,566,988	\$2,948,362	\$13,607,152
SBWRP TREATMENT COSTS										\$213,494,288	\$1,973,936	\$6,689,925	\$6,495,244	\$4,193,208	\$19,352,313
TREATMENT COST SUBTOTAL										\$213,494,288	\$1,973,936	\$6,689,925	\$6,495,244	\$4,193,208	\$19,352,313
Waste Streams															
	Sludge non-pumped forcemain or solids processing upgrade needed by WWMP	0.00		mgd	0.0	1	\$243	LF	0	N/A					
WASTE STREAM COSTS										\$0					\$0
COLLECTIONS SYSTEMS IMPROVEMENTS															
Pump Stations															
SV8	Upsize SV08 PS to SBWRP ; ratio = 30/133	109	130	hp		2	\$26,608	hp	130	\$3,469,091					\$189,038
Pipeline															
Gravity															
SV8	Upsize to SV08; 66"-57" = 9" Net Increase	31.1	62.2	mgd	9.0	1	\$166	LF	1,000	\$166,389					\$1,664
Force Main															
SV8	SV08 FM; 66"-57" = 9" Net Increase	31.1	62.2	mgd	9.0	1	\$147	LF	38,750	\$5,684,199					\$56,842
Tunneling															
					9.0		\$343	LF	8,350	\$2,865,948					\$28,659
COLLECTION SYSTEM COST SUBTOTAL										\$12,185,627					\$276,203
IPR Service															
Pump Station															
	SBWRP to Otay Lakes	2,788	3,345	hp	---	2	\$3,163	hp	3,345	\$10,580,343					\$2,889,655
Pipeline															
	SBWRP to Otay Lakes	15.0	15.0	mgd	30	1	\$533	LF	82,200	\$43,824,355					\$438,244
IPR SERVICE SUBTOTAL										\$54,404,698					\$3,327,898
SUBTOTAL										\$280,084,612					\$22,956,415
Soft Cost															
	Contingency		% of Subtotal	40%						\$112,033,845					
	EL&A		% of Subtotal	20%						\$56,016,922					
	Environmental		% of Subtotal	20%						\$56,016,922					
	Construction Management		% of Subtotal	10%						\$28,008,461					
SOFT COST SUBTOTAL										\$252,076,151					
TOTAL CAPITAL & O&M COSTS (AFTER PLANNED WWMP UPGRADES AT PLWTP)										\$532,160,763					\$22,956,415

SOUTH BAY - MODULE C2

Up to tertiary	44.0 mgd required average capacity up to secondary at the South Bay WRP 44.0 mgd installed average capacity up to secondary at the South Bay WRP
	29.0 mgd required average capacity of tertiary facilities at the South Bay WRP 29.0 mgd installed average capacity of tertiary facilities at the South Bay WRP
AWPF	17.7 mgd required average capacity of AWPf at the South Bay WRP 17.7 mgd installed average capacity of AWPf at the South Bay WRP

256,016,389.84
20,154,654.89

Notes
a Some capacities indicate Incremental capacity installed if existing capacity is adequate. Otherwise, full capacity installed if complete replacement required.
b Gravity sewer diameters determined using "Sewer-Slide Hydraulics Calculator"

APPENDIX G: NATIONAL WATER RESOURCE
INSTITUTE WHITE PAPER



This page intentionally left blank.

National Water Research Institute

AN NWRI WHITE PAPER

Direct Potable Reuse: Benefits for Public Water Supplies, Agriculture, the Environment, and Energy Conservation

Prepared by:

**EDWARD SCHROEDER, GEORGE TCHOBANOGLIOUS,
HAROLD L. LEVERENZ, AND TAKASHI ASANO**

*Department of Civil and Environmental Engineering
University of California, Davis*



This page intentionally left blank.

NWRI White Paper

**Direct Potable Reuse:
Benefits for Public Water Supplies, Agriculture,
the Environment, and Energy Conservation**

Prepared by:

Edward Schroeder, George Tchobanoglous,
Harold L. Leverenz, and Takashi Asano
Department of Civil and Environmental Engineering
University of California at Davis
Davis, California

Prepared for:

National Water Research Institute
Fountain Valley, California

January 2012

This page intentionally left blank.

About NWRI

A 501c3 nonprofit organization, the National Water Research Institute (NWRI) was founded in 1991 by a group of California water agencies in partnership with the Joan Irvine Smith and Athalie R. Clarke Foundation to promote the protection, maintenance, and restoration of water supplies and to protect public health and improve the environment. NWRI's member agencies include Inland Empire Utilities Agency, Irvine Ranch Water District, Los Angeles Department of Water and Power, Orange County Sanitation District, Orange County Water District, and West Basin Municipal Water District.

For more information, please contact:

National Water Research Institute
18700 Ward Street
P.O. Box 8096
Fountain Valley, California 92728-8096 USA
Phone: (714) 378-3278
Fax: (714) 378-3375
www.nwri-usa.org

Jeffrey J. Mosher, Executive Director
Gina Melin Vartanian, Editor

© 2012 by the National Water Research Institute. All rights reserved.

Publication Number NWRI-2012-01

ACKNOWLEDGMENTS

This NWRI White Paper was prepared by Edward Schroeder, George Tchobanoglous, Harold L. Leverenz, and Takashi Asano of the University of California, Davis. Special thanks are extended to Gina Melin Vartanian of NWRI and Professor Rafael Mujeriego of the Polytechnic University of Catalonia for their help and advice.

CONTENTS

ACRONYMS AND UNITS OF MEASURE	iv
1. INTRODUCTION	1
2. BENEFITS OF DIRECT POTABLE REUSE	2
2.1 Benefits for Public Water Supplies	2
2.2 Benefits for Agriculture	2
2.3 Benefits for the Environment	3
2.4 Reduced Energy for Pumping Water	3
3. SOUTHERN CALIFORNIA – AN EXAMPLE	4
3.1 Current Southern California Water Supply	4
3.2 Value of Agriculture in the San Joaquin Valley	5
3.3 Potential for DPR in Southern California	6
3.4 Stabilization of the San Joaquin Valley Water Districts’ Supply	8
3.5 Environmental Enhancement	8
3.6 Energy Conservation	9
4. IMPLICATIONS OF FINDINGS AND NEXT STEPS	11
5. SUMMARY	12
6. REFERENCES	13

TABLES

1. Estimated Freshwater Use by Public Systems in Southern California Counties in 2005	4
2. State Water Project Allocations to MWD and San Joaquin Valley Water Districts	5
3. Data for Selected California Crops Produced Principally in the Central Valley in 2008	6
4. Quantities of Municipal Wastewater Discharged to the Pacific Ocean and Recycled in Southern California	7
5. Electric Power Consumption in Typical Urban Water Systems	9

ACRONYMS

DPR	Direct potable reuse
H ₂ O ₂	Hydrogen peroxide
IPR	Indirect potable reuse
MWD	Metropolitan Water District of Southern California
TDS	Total dissolved solids

ABBREVIATIONS FOR UNITS OF MEASURE

ac	Acre; 43,560 ft ² [(5,280 ft/mi) ² × (640 ac/mi ²)]
ac-ft	Acre-foot
ft	Foot
gal/capita·d	Gallons per capita per day
gal/lb	Gallons per pound
GWh/yr	Gigawatt hour per year
ha	Hectare; ten thousand square meters (100 m × 100 m)
hm ³	Cubic hectometer; million cubic meters (100 m × 100 m × 100 m)
hm ³ /d	Cubic hectometer per day; million cubic meters per day
hm ³ /yr	Cubic hectometer per year; million cubic meters per year
kg	Kilogram
km	Kilometer
kWh	Kilowatt
kWh/ac-ft	Kilowatt hour per acre-foot
kWh/m ³	Kilowatt hour per cubic meter
kWh/Mgal	Kilowatt hour per million gallons
L/capita·d	Liter per capita per day
m	Meter
Mac-ft	Million acre-feet
Mac-ft/yr	Million acre-feet per year
mg/L	Milligram per liter
Mgal/d	Million gallons per day
Mgal/yr	Million gallons per year
mi	Mile
Mlb	Million pounds
m ³	Cubic meter
m ³ /kg	Cubic meter per kilogram
tonne	Metric tonne (1,000 kg)
TWh/yr	Terawatt-hour per year
μm	Micrometer

1. INTRODUCTION

Direct potable reuse (DPR), in which purified municipal wastewater is introduced into a water treatment plant intake or directly into the water distribution system, is becoming an increasingly attractive alternative to developing new water sources (Tchobanoglous et al., 2011). The rationale for DPR is based on the technical ability to reliably produce purified water that meets all drinking water standards and the need to secure dependable water supplies in areas that have, or are expected to have, limited and/or highly variable sources. To meet the purification level required, wastewater treated by conventional means undergoes additional treatment steps to remove residual suspended and dissolved matter, including trace organics. Questions of public acceptance are answered, in part, by the successful incorporation of DPR in the small resort town of Cloudcroft, New Mexico; by the Colorado River Water District serving a population of 250,000 in Big Spring, Stanton, Midland, and Odessa, Texas; and by the results of a recent public acceptance survey (Macpherson and Snyder, in press).

The focus of this white paper is on the role that DPR will have in the management of water resources in the future. For example, in many parts of the world, DPR will be the most economical and reliable method of meeting future water supply needs. The topics considered in this white paper include:

- An examination of beneficial impacts of DPR.
- A case study to demonstrate the relationship between DPR and urban water supplies, agriculture, the environment, and energy conservation, based on Southern California and the California State Water Project.
- The next steps that should be taken by water agencies to prepare for DPR in the future.

2. BENEFITS OF DIRECT POTABLE REUSE

Direct potable reuse can be implemented to provide a new and stable source of water supply for cities. However, the potential benefits accrued for agriculture, environmental preservation and enhancement, and energy conservation through the application of DPR may be more important.

2.1 Benefits for Public Water Supplies

Alternative solutions to meet urban water supply requirements include the development of inter-basin water transfer systems, desalination of brackish water and seawater, and DPR. With inter-basin transfer, the availability of water for food production is limited, source area ecosystems are often destroyed, and transmission systems are subject to damage from earthquakes, floods, and other natural and human-made disasters. With desalination, energy requirements are comparatively large and brine disposal is a serious environmental issue. By comparison, DPR will have relatively modest energy requirements and provide a stable local source of water that is less subject to natural disasters. Because the water requirements of cities are greater than wastewater discharges, DPR will not be a stand-alone water supply. However, in many cases, sustainable local sources combined with DPR will be adequate. The application of DPR to create decentralized water resource management systems will allow the use of less pumping and energy consumption – factors that will mitigate increased treatment costs.

As urban areas grow, pressure on local water supplies, particularly groundwater, will increase. At present, groundwater aquifers used by over half of the world population are being over-drafted (Brown, 2011). The attractiveness of DPR will increase as the world's population becomes increasingly urbanized and concentrated near coastlines where local water supplies are limited and brine disposal is possible (Creel, 2003).

2.2 Benefits for Agriculture

Water exported for urban use decreases its availability for food production. The present world population of 7 billion is expected to reach 9.5 billion by 2050 (U.S. Census Bureau, 2011). A pattern of increased incorporation of animal and dairy products into the diet as people become more affluent and the need to protect aquatic ecosystems provide additional demands on the available water in source regions. The impact of diet on water use is demonstrated by the following statistics (Pimentel and Pimentel, 2003):

- Beef requires 12,000 gallons per pound (gal/lb) [100 cubic meters per kilogram (m^3/kg)] of water.
- Soybeans require 240 gal/lb ($2.0 m^3/kg$) of water.
- Wheat requires 110 gal/lb ($0.90 m^3/kg$) of water.

Municipal wastewater generation in the United States averages approximately 75 gallons per capita per day (gal/capita•d) [280 liters per capita per day (L/capita•d)] and is relatively constant throughout the year. Where collection systems are in poor condition, the wastewater generation rate may be considerably higher or lower due to infiltration/inflow or exfiltration, respectively. Thus, the potential municipal water supply offset by DPR for a community of 1-million people

will be approximately 75 million gallons per day (Mgal/d) [0.28 million cubic meters per day (hm^3/d)] or 27,400 million gallons per year (Mgal/yr) [104 million cubic meters per year (hm^3/yr)]. Assuming adequate storage is available and evaporation losses are minimal, the water saved in the source region through the application of DPR by a population of 1-million people could result in the annual production of 2.3 million pounds (Mlb) (1,050 tonne) of beef, 114 Mlb (51,800 tonne) of soybeans, or 253 Mlb (115,000 tonne) of wheat. Given losses at various points in the system, the actual available water would most likely be about 50 percent of the potential value, but resulting agricultural production would still be impressive.

2.3 Benefits for the Environment

The elimination or minimization of water importation to cities through inter-basin transfers will reduce environmental impacts resulting from the construction of reservoirs and canals. A classic example of an environmental impact resulting from inter-basin transfers is the purchase of land and water rights in the Owens Valley, which is east of the Sierra Nevada, by the City of Los Angeles in the early twentieth century (Los Angeles Department of Water and Power, 2004). The City constructed reservoirs and the 233 mile (mi) [375 kilometer (km)] Los Angeles Aqueduct that stripped the valley of water for farming and cut off water to Owens Lake. Agriculture in the Owens Valley was decimated. Owens Lake dried up and became a major source of airborne particulate matter. In fact, dust emission from the dry lakebed is the nation's largest source of particles less than 10 micrometer (μm) in size and accounts for approximately 6 percent of all dust generation in the United States (Gill and Cahill, 1992; U.S. Environmental Protection Agency, 2004). Extension of the aqueduct into the Mono Lake watershed in 1941 resulted in the loss of 31 percent of the lake volume over the following 40 years. Suits by local governments and environmental groups have resulted in decreases in water imports by the City, a significant rise in the water level of Mono Lake, and a plan to manage dust emissions from Owens Lake.

2.4 Reduced Energy for Pumping Water

Inter-basin transfers of water often require large expenditures of energy to pump water over the mountain ranges separating and defining the basins. As a gravity flow system, the Los Angeles Aqueduct is somewhat of an exception to the general rule. However, the much larger Colorado River Aqueduct constructed in the 1930s by the Metropolitan Water District of Southern California (MWD) is an example of the amount of energy often required to import water to urban regions (Wilkinson, 2007). To bring 1.2 million acre-feet per year (Mac-ft/yr) ($1,500 \text{ hm}^3/\text{yr}$) of water from the Colorado River to Southern California requires lifting water 1,616 feet (ft) [493 meters (m)] and a net power input of 2,400 gigawatt hours per year (GWh/yr) [2,000 kilowatt hours per acre-foot (kWh/ac-ft), 1.6 kilowatt hours per cubic meter (kWh/m^3)], not including the energy and materials required to construct and maintain the 242 mi (387 km) aqueduct consisting of 63 mi (101 km) of canals, 92 mi (147 km) of tunnels, and 84 mi (134 km) of pipes and siphons (Wilkinson, 2007).

3. SOUTHERN CALIFORNIA – AN EXAMPLE

Using a portion of the treated wastewater now being discharged to the Pacific Ocean through the application of DPR could stabilize the water supplies for both Southern California and San Joaquin Valley agriculture, significantly decrease the energy required for transporting water, protect and enhance the ecosystems of the Sacramento-San Joaquin Delta, and decrease the pollution of near shore waters and beaches in Southern California.

3.1 Current Southern California Water Supply

Four counties in Southern California (Los Angeles, Orange, Riverside, and San Diego) import the major portion of their water from Northern California through the State Water Project, the Colorado River, and the Owens Valley. With the exception of the portion from the Owens Valley, water importation is managed by MWD. Estimated average daily use in the four counties is 3,110 Mgal/d (3.48 Mac-ft/yr; 4,290 hm³/yr), as shown in Table 1. The California State Water Project has a projected supply of over 4.0 Mac-ft/yr (4,900 hm³/yr). A maximum allotment of 2.56 Mac-ft/yr (3,160 hm³/yr) is contracted to Southern California water agencies, of which 2.01 Mac-ft/yr (2,480 hm³/yr) is allotted to MWD. Water districts in the San Joaquin Valley have a maximum allotment of 1.20 Mac-ft/yr (1,480 hm³/yr), with 83 percent allotted to the Kern County Water Agency. Nearly all of the water allotted to districts in the San Joaquin Valley is used for agriculture.

Table 1: Estimated Freshwater Use by Public Systems in Four Southern California Counties in 2005^a

Item	Los Angeles	Orange	San Diego	Riverside
Population (1,000s)	9,935	2,988	2,933	1,946
Water Use by County (Mgal/d ^b)				
Groundwater	331	49	75	86
Surface Water ^c	1,529	335	356	349
Total	1,860	384	431	435

^a Adapted from U.S. Geological Survey (2005).

^b 264 Mgal/d = 1 hm³/d.

^c Nearly all imported through inter-basin transfers.

“Maximum” is a key word in describing the distribution of State Project water. Since 2000, the allocations have averaged 69 percent of the maximum value, with average values for MWD and the San Joaquin Valley water districts being 1.35 and 0.83 Mac-ft/yr (1,670 and 1,020 hm³/yr), respectively, as reported in Table 2. Southern California has responded to water supply limitations through water use restrictions, increased emphasis on conservation, and new water recycling projects emphasizing groundwater recharge. Water limitations to the San Joaquin

Valley water districts have been responded to, in part, by improved irrigation management and planting crops that have low water requirements, but the principal response is to reduce cultivated land.

Table 2: State Water Project Allocations to MWD and San Joaquin Valley Water Districts^a

Year	Total All Contractors (Mac-ft/yr^b)	Percent of Capacity	MWD (Mac-ft/yr^b)	San Joaquin Valley (Mac-ft/yr^b)
Maximum	4.13	100	2.01	1.20
2011	3.34	80	1.53	0.91
2010	1.88	50	0.96	0.57
2009	1.67	40	0.76	0.47
2008	2.46	35	0.67	0.41
2007	2.47	60	1.21	0.72
2006	4.13	100	1.91	1.17
2005	3.71	90	1.72	1.05
2004	2.68	65	1.31	0.77
2003	3.71	90	1.81	1.08
2002	2.89	70	1.41	0.84
2001	1.61	39	0.78	0.47
2000	3.41	83	1.51	1.10
Average	2.93	69	1.35	0.83

^a Adapted from California Department of Water Resources (2011).

^b 1 Mac-ft/yr = 1,233 hm³/yr.

The predicted impacts of climate change on water supplies in California include an overall decrease in annual precipitation, greater year-to-year variability, larger storms, and longer droughts. Thus, the variation in future allocations from the State Water Project is likely to become greater than those experienced since 2000.

3.2 Value of Agriculture in the San Joaquin Valley

The San Joaquin Valley of California is the most productive agricultural region in the world, but depends almost completely on irrigation because of limited annual precipitation extending from May through October. The value of agriculture in the valley will increase as global population increases and crops suitable for energy production are grown. The principal crops include a wide range of vegetables, grapes, melons, nuts, and stone fruits, many of which are grown almost exclusively in the valley, as shown in Table 3. Although a small portion of the total U.S. cotton

crop, 90 percent of the nation’s long fiber Pima cotton is grown in the valley (Starrs and Goin, 2010). Similarly, hay production is a small portion of the national crop, but is used locally for the large dairy herds in the valley that make California the leading producer of milk and cheese in the U.S. Although not usually recognized as a wine producing region, approximately 380,000 acres (ac) (150,000 hectares [ha]) of the State’s 535,000 ac (217,000 ha) of wine grapes are grown in the Central Valley.

Table 3: Data for Selected California Crops Produced Principally in the Central Valley in 2008^a

Crop	Percentage of U.S. Commercial Crop	Area Planted (ac^b)	Dollar Value	Approximate Annual Water Requirement (ft^b)
Almonds	99	680,000	2,400,000,000	4.3
Walnuts	99	218,000	750,000,000	3.3
Pistachios	96	150,000	600,000,000	3.5
Peaches	70	55,000	498,000,000	3.5
Nectarines	98	31,000	284,000,000	2.8
Pears	29	14,000	106,000,000	2.8
Apricots	95	24,100	35,000,000	2.9
Plums	99	102,000	218,000,000	2.9
Oranges	30	184,000	1,100,000,000	3.9
Mandarins ^c	37	16,000	77,152,000	3.9
Grapes	91	590,000 ^d	4,000,000,000	3.0
Cantaloupe	55	46,000	150,000,000	2.5
Tomatoes-processing ^e	95	276,000	812,000,000	2.1
Hay	6	570,000	1,400,000,000	4.0
Cotton	8	268,000	326,000,000	2.4

^aAdapted from Starrs and Goin (2010).

^b2.47 ac = 1 ha; 3.28 ft = 1 m.

^cCalifornia Fruit and Nut Review (2008).

^dCentral Valley only.

^eCalifornia Processing Tomato Report (2008).

3.3 Potential for DPR in Southern California

Treated wastewater in the four Southern California counties is recycled for urban applications, used to recharge groundwater, or discharged to the Pacific Ocean. The greatest fraction of municipal wastewater is conveyed to treatment plants near the coast and discharged into the

Pacific Ocean through long ocean outfalls. Ocean discharge, comprising the most available source water for DPR, averages 1,259 Mgal/d [1.410 Mac-ft/yr (1,739 hm³/yr)], as reported in Table 4. Purified water used for groundwater recharge is primarily from the upper reaches of the drainage basins and must be treated at least to the tertiary level. A significant portion of the wastewater is not used for recharge because of high salt concentrations.

Table 4: Quantities of Municipal Wastewater Discharged to the Pacific Ocean and Recycled in Southern California^a

Drainage Basin	Quantity (Mgal/d ^b)	
	Ocean	Recycled
Los Angeles	696	206
Santa Ana	246	44
San Diego	317	37
Total	1,259	287

^a Adapted from Heal The Ocean (2010).

^b 264 Mgal/d = 1 hm³/d.

A model for potable reuse has been provided by the Orange County Water District, which operates a 70 Mgal/d (0.26 hm³/d) advanced treatment facility purifying wastewater to drinking water standards and beyond (Orange County Water District, 2011). About half of the water is used for indirect potable reuse (IPR) through surface infiltration to the aquifer with an approximate residence time of 6 months, and the other half is used for injection wells to prevent seawater intrusion into coastal aquifers. It should be noted that the quality of purified water is reduced when it is blended into groundwater aquifers due to the presence of groundwater constituents.

Water Quantity: Treating a significant fraction of the wastewater now being discharged to the ocean to drinking water standards and introducing DPR will stabilize the water supply in Southern California. For example, using one-half the volume now discharged to the ocean [0.70 Mac-ft/yr (860 hm³/yr)], would make up the difference between the average water allotment since the year 2000 and maximum State Water Project. Further, in the event that the delivery of State Water Project water to Southern California was interrupted due to an unforeseen event, such as a natural or human-made disaster, a substantial local water supply would still be available.

Water Quality: Improvement in Southern California water quality is an added benefit of DPR. State Project and Colorado River water have total dissolved solids (TDS) concentrations of approximately 300 and 650 milligrams per liter (mg/L), respectively, and contain trace organic compounds from agricultural runoff and upstream cities, most notably Las Vegas, Sacramento, and Stockton (Metropolitan Water District of Southern California, 2010, 2011a). Water leaving the DPR treatment facilities will have a TDS concentration of about 50 mg/L after mineral addition to provide chemical stabilization.

Cost of DPR: The Orange County Water District obtains treated wastewater from the Orange County Sanitation District (Orange County Water District, 2011). The treatment steps include microfiltration, reverse osmosis, and advanced oxidation with ultraviolet light and hydrogen peroxide (H₂O₂), and combined chlorine disinfection. The total capital and operating costs of treatment for the 2009-2010 fiscal year was \$747/acre-foot (ac-ft) [\$0.61/cubic meter (m³)]. For comparison, MWD sells treated potable water for \$742/ac-ft (\$0.60/m³) and untreated water for \$527/ac-ft (\$0.43/m³), with increases to 794 and \$560/ac-ft (0.64 and \$0.45/m³), respectively, starting in January 1, 2012 (Metropolitan Water District of Southern California, 2011b).

The Value of Water: In addition to the above considerations, the value of the purified water relative to other water sources must also be considered in assessing the potential of DPR. Such an assessment is of importance in light of recent court decisions regarding the allocation of water from Northern California and from the Colorado River to Southern California. Based on an analysis by the California Department of Water Resources, the cost of developing additional water supply in Southern California ranges from about 1,000 to \$10,000/ac-ft (0.81 to \$8.10/m³) for alternatives such as desalination, water storage, and water conservation; municipal water reuse projects were identified as the least-cost, highest-gain option for long-term water supply reliability (Legislative Analyst's Office, 2008). A marginal cost analysis would be needed to assess the potential value of DPR as a water source.

3.4 Stabilization of the San Joaquin Valley Water Districts' Supply

The production of 0.70 Mac-ft/yr (860 hm³/yr) of potable water through DPR in Southern California would make the same volume available to San Joaquin Valley water districts on a reliable basis. In low precipitation years, such as 2008, when allotments were 35 percent of the maximum, the districts could receive close to a full allotment [0.40 + 0.70 Mac-ft (490 + 860 hm³)]. In years with more precipitation, the excess water could be used for other purposes, such as increasing farmed acreage, enhancement of the Sacramento-San Joaquin Delta, increasing storage volume, or groundwater recharge in the Central Valley. Water made available in the San Joaquin Valley through DPR in Southern California does not need to be treated before use in irrigation.

The decision of how the water made available would be allocated will be difficult because of the number of stakeholders involved. Farmers, environmentalists, and water districts in the San Francisco Bay area and originating areas north of Sacramento, as well as Southern California water districts, will become involved.

3.5 Environmental Enhancement

Instituting DPR in Southern California could greatly decrease environmental stress on the Sacramento-San Joaquin Delta. The State Water Project was highly controversial because of the environmental impacts foreseen and because water originating north of Sacramento was being transferred to the San Joaquin Valley and, more significantly, to Southern California. The initial phase of the California State Water Project, comprising 34 reservoirs and dams and 700 mi (1,120 km) of canals and pipelines, was completed in 1973. Since 1973, some additional phases have been completed, such as the 100 mi (160 km) coastal branch conveying water to San Luis

Obispo and Santa Barbara Counties. However, what remains unresolved is how best to convey water through or around the Sacramento-San Joaquin Delta.

The protection of endangered species, notably Delta smelt and winter-run salmon, and preventing salinity intrusion that impacts both the Delta ecosystems and water quality of communities in the East Bay and of water entering the California Aqueduct at the south end of the Delta, have resulted in a political stalemate for nearly 40 years. Numerous studies have been conducted and solutions proposed that address the environmental issues of the Delta. Each proposed solution has been attacked by one or more of the stakeholders – Delta environmental groups, Delta and East Bay water districts, MWD, and the San Joaquin Valley water districts receiving State Project water. A reliable source of 0.70 Mac-ft/yr (860 hm³/yr) produced by application of DPR (which is 17 percent of the maximum annual yield of the State Water Project) could address most of the concerns, if political agreement can be reached.

3.6 Energy Conservation

At present, 19 percent of the electric power consumption in California is used to transport water (California Energy Commission, 2005). Consumption for urban water use, including wastewater treatment, is approximately 3,800 kilowatt hours per million gallons (kWh/Mgal) [1,200 kWh/ac-ft (1.0 kWh/m³)], excluding conveyance. Importing water to Southern California requires an additional 8,750 kWh/Mgal [2,850 kWh/ac-ft (2.31 kWh/m³)], as reported in Table 5.

Table 5: Electric Power Consumption in Typical Urban Water Systems^a

Use	Power Consumption (kWh/Mgal ^b)	
	Northern California	Southern California
Supply and Conveyance	150	8,900
Treatment	100	100
Distribution	1,200	1,200
Wastewater Treatment	2,500	2,500
Total	3,950	12,700

^a Adapted from California Energy Commission (2005).

^b 3785 kWh/Mgal = 1 kWh/m³.

The energy required for the production of purified water will vary from 3,800 to 5,700 kWh/Mgal [1,200 to 1,900 kWh/ac-ft (1.0 to 1.5 kWh/m³)] beyond secondary treatment, depending on the wastewater total dissolved solids (i.e., about 500 to 1,000 mg/L). For comparison, desalination of seawater requires 13,000 to 15,000 kWh/Mgal [4,200 to 4,900 kWh/ac-ft (3.4 to 4.0 kWh/m³)]. The potential net energy savings in Southern California of

developing 0.70 Mac-ft/yr (860 hm³/yr) of purified water by DPR can be computed as the energy savings for supply/conveyance [estimated to be 8,750 kWh/Mgal (2.31 kWh/m³)] reduced by the energy input required for the purification process [estimated to range from 3,800 to 5,700 kWh/Mgal (1.0 to 1.5 kWh/m³)]. Thus, the estimated net energy savings ranges from 3,000 to 5,000 kWh/Mgal (0.8 to 1.3 kWh/m³), or 0.7 to 1 terawatt-hours per year (TWh/yr). At \$0.075/kWh, the savings would be 50 to \$87 million per year.

4. IMPLICATIONS OF FINDINGS AND NEXT STEPS

DPR is a technically feasible method of stabilizing water supplies for municipalities and agriculture; preventing, minimizing, or correcting environmental damage resulting from inter-basin water transfers; and conserving energy. However, the application of DPR on a large scale, such as in Southern California, will raise significant political issues related to the ownership of water that will need to be resolved.

Given appropriate terminology and context, there is strong support for DPR based on the findings from a recently completed study of public attitudes (Macpherson and Synder, in press). Based on this finding, it is clear that the water and wastewater industry should undertake an initiative to develop a planning process to examine the potential of DPR and impediments to its implementation.

One of the major steps that should be taken by the water and wastewater industry is to develop closer ties with respect to the management of available water resources. As water distribution system modifications and replacements are planned and implemented, attention should be focused on appropriate locations within an existing system where engineered storage buffers or water purification plants can be located (e.g., near existing water treatment plants or other suitable locations within the service area). Studies should be undertaken to assess what blending ratios would be acceptable with the existing water supply to protect public health, maintain water quality, and control corrosion.

For example, conventional wastewater treatment systems will need to be designed or modified to optimize overall performance and enhance the reliability of the DPR water purification system. Measures that can be undertaken to enhance the reliability of a DPR system include: enhanced (targeted) source control programs, enhanced physical screening, upstream flow equalization, elimination of untreated return flows, modifying the mode of operation of biological treatment processes, improved performance monitoring systems, and the use of pilot test facilities for the ongoing evaluation of new technologies and process modifications (Tchobanoglous et al., 2011).

5. SUMMARY

As a result of worldwide population growth, urbanization, and climate change, public water supplies are becoming stressed and tapping new water supplies for metropolitan areas is becoming more difficult, if not impossible. In the future, it is anticipated that DPR will become an imperative (Leverenz et al., 2011). When compared with other options, water reuse is the most cost-effective approach to long-term water supply sustainability. The case study of Southern California illustrates the potential impact of DPR: stabilization of water supplies for a large urban population and a major agricultural region and energy savings ranging from 0.7 to 1 TWh/yr, roughly a savings of \$50 to \$87 million per year. Thus, the steps that will be necessary to make DPR a reality and the elements of an implementation plan should be identified. Starting the planning process now will allow for early identification of the changes required to both the water and wastewater infrastructure to accommodate DPR. These findings are applicable not only in California, but also worldwide.

REFERENCES

Brown, L. R. (2011). "The New Geopolitics of Food," *Foreign Policy*, **4**, 1 – 11.

California Department of Water Resources (2011). Notice to State Water Project Contractors, State Water Project Analyst's Office, <http://www.water.ca.gov/swpao/notices.cfm>.

California Fruit and Nut Review (2008). National Agricultural Statistics Service, U.S. Department of Agriculture, www.nass.usda.gov/Statistics_by_State/California/Publications/Fruits_and_Nuts/200812frtrv.pdf

California Processing Tomato Report (2008). National Agricultural Statistics Service, U.S. Department of Agriculture, http://nass.usda.gov/Statistics_by_State/California/Publications/Vegetables/200808ptom.pdf

California Energy Commission (2005). Final Staff Report, California's Water-Energy Relationship, CEC-700-2005-011-SF, www.energy.ca.gov/2005publications/CEC-700-2005-011/CEC-700-2005-011-SF.PDF

Creel, L. (2003). "Ripple Effects: Population and Coastal Regions," Population Reference Bureau, Washington, DC.

Gill, T.E., and T.A. Cahill (1992). "Drying saline lake beds: a regionally-significant PM10 source," in J.C. Chow and D.M. Ono (eds.) *PM10 Standards And Nontraditional Particulate Source Controls*. Air and Waste Management Association Transactions Series, **22**, 440-454.

Heal The Ocean (2010). *California Ocean Wastewater Report and Discharge* http://healthocean.org/images/pages/research/HTO_COWDI.pdf

Legislative Analyst's Office (2008). *California Water: An LAO Primer*, Legislative Analyst's Office, Sacramento, CA.

Leverenz, H.L., G. Tchobanoglous, and T. Asano (2011). "Direct Potable Reuse: A future imperative," *Journal of Water Reuse and Desalination*, **1**, 1, 2-10.

Los Angeles Department of Water and Power (2004). *Securing LA's Water Supply*, www.ladwp.com/ladwp/cms/ladwp010587.pdf

Macpherson, L., and S. Snyder (in press). *Effect of Prior Knowledge of Unplanned Potable Reuse on the Acceptance of Planned Potable Reuse*, WRF-09-01, WaterReuse Research Foundation, Washington, DC.

Metropolitan Water District of Southern California (2010). *2010 Water Quality Table*, http://www.mwdh2o.com/mwdh2o/pages/yourwater/wq-report/PDFs/WQ_Table.pdf

Metropolitan Water District of Southern California (2011a). *2010 Water Quality Report*, <http://www.mwdh2o.com/mwdh2o/pages/yourwater/wq-report/index.html>

Metropolitan Water District of Southern California (2011b). Water rates and charges 2010 to 2012, http://www.mwdh2o.com/mwdh2o/pages/finance/finance_03.html#Anchor-Tier-6863

Orange County Water District (2011). Groundwater Replenishment System Project Cost http://www.gwrssystem.com/images/stories/pdfs/Operating_Costs_Fact_Sheet.pdf

Pimentel, D., and M. Pimentel (2003). “Sustainability of meat-based and plant-based diets and the environment,” *American Journal of Clinical Nutrition*, **78**, 3, 660S-663S.

Starrs, P.F., and P. Goin (2010). *Field Guide to California Agriculture*, University of California Press, Berkeley, CA.

Tchobanoglous, G., H.L. Leverenz, M.H. Nellor, and J. Crook (2011). *Direct Potable Reuse: The Path Forward*, WaterReuse Research Foundation and Water Reuse California, Washington, DC.

U.S. Census Bureau (2011). International Data Base, World Population: 1950 – 2050, <http://www.census.gov/population/international/data/idb/worldpopgraph.php>

U.S. Environmental Protection Agency Region 9 (2004). *Owens Valley Particulate Matter Plan: Fact Sheet*, <http://www.epa.gov/region9/air/owens/fact.html>

U.S. Geological Survey (2005). *Data Files for Estimated Use of Water in the United States*, <http://water.usgs.gov/watuse/data/2005/index.html>

Wilkinson, R.C. (2007). *Analysis of Energy Intensity for Water Supplies to the West Basin Water District*, West Basin Water District, Carson, CA.

APPENDIX H: RECYCLED WATER STUDY COST METHODOLOGY FREQUENTLY ASKED QUESTIONS



This page intentionally left blank.

APPENDIX H RECYCLED WATER STUDY COST METHODOLOGY SUMMARY

Frequently Asked Questions (FAQs) Format

The following information was prepared as a guide to aid in understanding the financial evaluation of alternatives in the Recycled Water Study. The financial evaluation was prepared to ultimately help decision-makers compare the costs of different water reuse approaches and to aid in making decisions about whether to invest in the water reuse system. The guiding principles for the evaluation included:

- Provide transparent costing of alternatives.
- Provide multiple opportunities at workshops and Stakeholder meetings to review, discuss, and debate project costs.
- Prepare a comparative financial evaluation of the Integrated Reuse Alternatives that includes financing costs.
- Compare the water reuse alternative costs to other options facing the City and Participating Agencies

Q. How were costs calculated, and was cost sharing discussed?

A. The financial evaluation process included the following steps:

- **Unit Costs.** Unit costs were developed from over 50 sources of information, including 23 bid summaries, two agency estimating tools, 14 project cost estimates, actual operating costs, and insight and experience from three national consulting firms.
- **Alternative Costs.** Capital costs (including engineering, administration, legal, land acquisition, environmental and construction management costs) and operational and maintenance (O&M) costs were compiled in an interactive excel model. Costs were thoroughly developed and reviewed in four interactive workshops and a series of status update meetings with the Project Stakeholders.
- **Financial Model Costs.** Capital and O&M costs for each alternative were entered into a net present value (NPV) financial model that included financing costs and other variables (described below). The financial model assumptions were closely coordinated with the City's financial staff to match typical City financing assumptions. The model was also vetted with the project stakeholder group (including the Participating Agencies' independent financial model expert).
- **Cost Framework.** A cost framework for sharing project costs between the City and Participating Agencies was outlined in the Study. Multiple options were outlined based on an interactive workshop with project stakeholders.



Q. How are costs presented in the Study?

A. Costs are presented in \$/acre feet (AF). Four tiers or thresholds are presented to provide a breakout for different conditions and to display values at each calculation step. The following summarizes the thresholds:

- **Gross Costs.** Gross costs include the capital and O&M costs for completing and operating the recycled water projects. The Gross Cost evaluation included a sensitivity analysis with a Favorable and Unfavorable scenario (see related question/answer below). The final Gross Costs include an average of these scenarios based on discussion and agreement with the Study's stakeholder group.
- **Tier 1 Net Costs – Direct Wastewater System Savings (Point Loma Related Savings).** Since the reuse projects offload flows going to Point Loma, there are savings that should be credited. These savings include:
 - Smaller Point Loma Plant secondary facilities (less flow is treated at Point Loma)
 - Smaller wet weather equalization basin (less flow reaches Point Loma)
 - Less pumping at Pump Station No. 2 (less flow is diverted to Point Loma)
 - Less pumping at Pump Station No. 1 (more reuse occurs at the South Bay Plant since more flow is diverted away from PS1)
- **Tier 2 Net Costs - Salt Credit Benefit.** This credit is \$100/AF and accounts for significant salinity reductions in the water, wastewater and reuse systems caused by the advanced purification elements of the reuse projects. This directly benefits municipal water and wastewater systems. There is an additional homeowner and business benefit which is not included in this value. An implementation step is included to discuss how this benefit is credited.
- **Tier 3 Net Costs - Indirect Wastewater Savings (Maintaining CEPT).** Completing these reuse project will significantly reduce Point Loma discharges. Conceptually, this reduction may be sufficient to meet mass emission targets and maintain the Point Loma Plant as a Chemically Enhanced Primary Treatment (CEPT) Facility. While this study does not establish an opinion on whether this approach should be taken, it does quantify the savings that occurs if this reuse program allows maintaining CEPT status at Point Loma. The breakout of this specific threshold is particularly important since there appears to be differing opinions on this issue between the Study's stakeholders.

Q. What were the Favorable and Unfavorable Scenarios?

A. The Gross Cost financial evaluation included a sensitivity analysis that used different assumptions for the following three variables: project contingencies (ranging from 20 to 40 percent), Grants (ranging from 10 to 30 percent), and Metropolitan Water District/Water Authority Local Resource Program (LRP) credits (ranging from \$100/AF to \$450/AF). The Favorable Scenario assumed the best case (20 percent contingency, 30 percent grants, \$450/AF LRP). The Unfavorable Scenario assumed the worst case (40 percent contingency, 10 percent grants, \$100/AF LRP). This sensitivity analysis was performed since stakeholder opinions varied on what the proper assumption should be. For the report, the Stakeholder group agreed to use an average of these values.

Q. How were the Net 1 Direct Wastewater System Savings Calculated?

A. The latest savings calculations were revised between October 2011 and January 2012 to coordinate the efforts of this Study with the City's September 2011 Draft Wastewater Master Plan (WMP), which included updated flow projections. The cost savings are based on a comparison between the Recycled Water Study and the WMP. One key adjustment to the WMP was adjusting it to provide a comparable secondary treatment option. Backup tables regarding these calculations are provided as Attachments 1 and 2. A comparative figure is included as Attachment 3 and 4.

Q. Were specific cost responsibilities determined for Metro wastewater users (including the City and Participating Agencies [PAs])?

A. No. The cost sharing will be a negotiated discussion that is assumed to occur in coordination with Point Loma Plant permit negotiations (in the implementation steps). Cost sharing methodologies were conceptualized in Chapter 8 of the report. The graphic below was developed and presented in the March 2012 Report Review Session recognizing that this is an important question. This graphic depicts how the savings from the comparative analysis was applied to the Net Cost calculations. In summary, the comparative analysis does not try to allocate costs to each agency, it simply attempts to calculate comparable costs between a wastewater centric approach (WMP) and a reuse centric approach (the Recycled Water Study) and then allocates the savings to the reuse program (i.e. wastewater costs are unchanged). The wastewater system benefits include reduced ocean discharge per the goals of the study, and assumed stakeholder support from environmental groups and possible deferral of Point Loma upgrades while the reuse program is being build (pending Point Loma permit negotiations).



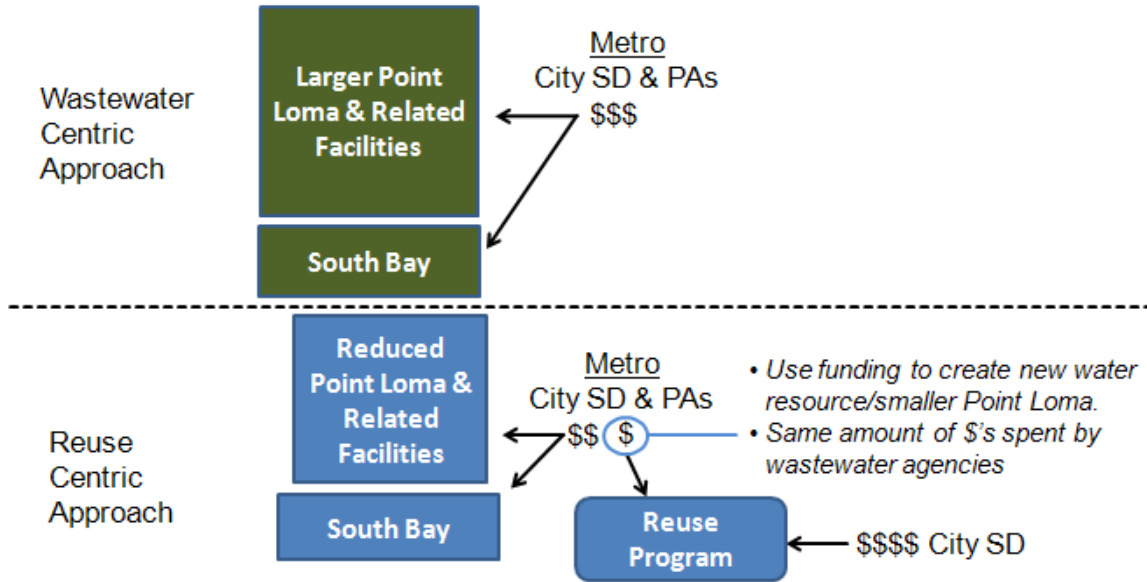

Benefits:

- New Water Created at Reasonable Rate
- Water and Wastewater Quality Improves (lower TDS - salt)
- Ocean Water Quality Improves (less mass emissions)
- Environmental Stakeholder Support

Q. How are South Bay Reuse Costs Calculated?

A. South Bay reuse costs were calculated by including the costs required to upsize the treatment facilities and bypass system beyond the improvements planned in the City’s September 2011 Wastewater Master Plan. The comparative Figure in Attachment 3 and 4 and the table below displays the responsibilities between the WMP and the Recycled Water Study. The incremental cost used in the cost analysis is based on the flow differential shown in this Table. Three major facilities are affected by this cost split: the South Bay Plant treatment systems through secondary processes, and the pump station and force main that diverts wastewater southward from the Spring Valley No. 8 connection (SV08) to the South Bay Plant. (also reference: “Why are the updated Gross Costs Lower?” below)

Facility	Total Planned (mgd)	Wastewater Master Plan (mgd)	Recycled Water Study (mgd)
South Bay Plant treatment; SV08 Diversion Pump Station; SV08 Forcemain	47 mgd (average) 133 mgd (peak)	21 mgd (average) 103 mgd (peak)	26 mgd (average)* 30 mgd (peak)

Notes:

The South Bay 26 mgd expansion shown in the Recycled Water Study is not needed for average reuse production provided the 21 mgd plant expansion is built via the WMP. The 26 mgd plant expansion in the reuse plan is an alternate disposal approach used to keep the Point Loma Plant smaller to avoid high rate clarifiers. Therefore, this facility is likely not needed until after 2035. Multiple scenarios were performed for allocating South Bay Plant costs.



Q. Why are the updated Gross Costs lower?

A. The Gross Costs are lower than earlier drafts and are now closer to the net costs. The reductions are related to how the South Bay costs are accounted for. Previously, the Gross Cost category of the Recycled Water Study carried all the costs to upgrade the South Bay system. Then, in the Tier 1 Net Costs, facilities attributable to the wastewater system were subtracted (or credited) from the Recycled Water Study costs. The new approach is more straightforward in that the Recycled Water Study only carries the differential South Bay costs (i.e. it does not add then subtract the same facilities). The costs included were evaluated in multiple scenarios per Attachments 3 and 4 (also reference: “How are South Bay Reuse Costs Calculated?” above).

Q. Are the Net 1 & Net 3 Wastewater System Savings credited to the Reuse Study Aggressive or Conservative?

A. The wastewater system savings were discussed and coordinated with wastewater planning staff. There are a number of assumptions in this analysis, which were evaluated through sensitivity scenarios using the financial model and the avoided cost calculations included as Attachments. The Study tries to balance the assumptions to provide a realistic cost picture. The following are some considerations:

Type of use assumed. It was concluded that only indirect potable reuse should be considered during the critical wet weather event scenario. Non-potable recycled water use is not assumed to occur within the City, Padre Dam or Otay Water District for this scenario since it is a “wet-year.” While non-potable demands are significantly reduced during wintertime and wet weather events, the assumption to not include any non-potable production likely means the yearly O&M savings are underestimated since the Recycled Water Study includes (on average) 3 mgd more non-potable recycled water use than the WMP. This is not considered a significant savings, but should be considered if other assumptions are challenged.

South Bay. South Bay cost assumptions are challenging since the facility serves as both an end-of-line wastewater plant and a reuse plant. Multiple scenarios were run regarding wastewater system costs and South Bay configurations. The results matched the current net costs shown in the March 2012 Report. The key assumptions include the timing of the 26 mgd expansion and O&M allocations (what is a water cost, what is a wastewater cost, and what is an existing reuse program cost). Because this is an important refinement to determine final cost sharing, the South Bay Plant implementation step was expanded to address the timing and responsibilities for South Bay as this is an important element in determining the final cost sharing approach.

Other Wastewater system savings. The reduction in flows through Pump Station No. 1 and No. 2 would likely reduce pump maintenance, replacement costs and capital costs in addition to power. Only power savings are currently credited to the reuse projects. Therefore, the reuse program would likely create more savings at these locations than currently estimated. In addition, rehabilitation of primaries at Point Loma was included in the reuse program scenario and not the WMP scenario in the avoided cost calculations, which adds additional conservatism to the comparative cost analysis.



Conclusions. Overall, the favorable/unfavorable and avoided cost sensitivity analyses produces results generally with +/- \$200/AF of the values shown in the conclusions. While assumptions can be scrutinized, the key is to finish this study and hold negotiations on the Point Loma permit requirements and Cost Sharing. Once these terms are defined, an accurate cost estimate can be developed and provided to all Stakeholders.

Q. Are there other reuse project savings not included?

A. It is likely that there are material water system savings that may occur as a result of completing the reuse projects. Completing the proposed reuse projects reduces the need to import water. Reducing imported water may reduce the City's liability in pending California Bay-Delta improvements. The reuse projects may also decrease the need to expand conveyance facilities to deliver imported untreated water to the City. Since these impacts are not yet clear, the Study captures these as qualitative considerations. Quantitative values were not applied to the estimates to avoid overstating cost savings from speculative avoided facilities.

Q. How are alternative costs dealt with?

A. There are five (5) refined alternatives in the Recycled Water Study. The cost thresholds described above (Gross, Net 1, Net 2, and Net 3) are included for each of the five alternatives.

Q. What are the current cost estimates for the alternatives, based on the recent coordination efforts with the September 2011 Draft Wastewater Master Plan?

A. The following table summarizes the updated study costs. The Net Costs are nearly identical to the 2011 Draft presented to the Stakeholder group (described further in a question below).

Cost Tier	Average of all Alternatives (A1, A2, B1, B2, B3)		Average of Least Cost Alternatives (B1, B2)	
	January 2012 (NEW)	August 2011 (PREVIOUS)	January 2012 (NEW)	August 2011 (PREVIOUS)
Gross Cost	\$1,800	\$2,200	\$1,700	\$2,100
Tier 1 Net Costs: Point Loma Savings	\$1,200	\$1,200	\$1,100	\$1,100
Tier 2 Net Costs: Salt Credit	\$1,100	\$1,100	\$1,000	\$1,000
Tier 3 Net Costs: Maintaining CEPT	\$700	\$700	\$600	\$500

Notes:

- Net Cost tiers include savings from the previous step.
- Gross Cost values represent the average of the favorable and unfavorable scenarios, which varied the project contingency, grants and LRP credit values.

Q. Why are the updated Net Costs the same or slightly lower than the previous results?

A. The Net costs are nearly identical in all cases. There are competing issues that led to this result. The main influencer is related to increased design flows for the Point Loma Plant, which causes the Point Loma Plant to be larger than previous versions of this Study. The larger plant means the initial Recycled Water Study goal of avoiding more expensive Biological Aerated Filter (BAF) treatment processes cannot be achieved. Even though the Point Loma Plant size increased and BAF was not avoided, the costs increased proportionally between the Wastewater Master Plan and the Recycled Water Study. Since the Net 1 and Net 3 Costs are based on the differential savings between these two studies, little change occurred.

Q. Are these results considered favorable?

A. These results are considered very favorable for the following reasons:

- The reuse costs are comparable to existing untreated water delivery costs of \$904/AF. Raw water costs are projected to rise substantially in the future
- The new reuse supply reduces the region's reliance on imported water and increases local water supply reliability
- The reuse solutions are more sustainable and environmentally friendly
- The reuse solutions produce additional water quality benefits such as significant regional salinity reductions
- The solutions increase the City and Participating Agencies' ability to control long term costs (both water supply and wastewater disposal)
- The solutions are supported by environmental stakeholders



This page intentionally left blank.

Attachment 1 – Point Loma Avoided Cost Calculation Summary

SUMMARY OF WASTEWATER SYSTEM SAVINGS DUE TO REUSE PROJECTS

TYPE	COMPONENT	SAVINGS	KEY
Capital Cost Savings (Total)	Smaller secondary capacity needed at the Point Loma Plant (143 mgd vs. 240 mgd)	\$434,447,915	1
	7 million gallon smaller Wet Weather Equalization Basin	\$123,000,000	3
	Subtotal Capital Cost	\$557,447,915	
O&M Savings (Annual)	Lower Point Loma Plant flows (Primary and Secondary) (143 mgd vs. 240)	\$18,654,416	1
	Less pumping from Pump Station No. 2 to the Point Loma Plant (-73 mgd)	\$2,200,000	4
	Less pumping from Pump Station No. 1 to Pump Station No. 2 (-26 mgd)	\$600,000	5
	7 million gallon smaller Wet Weather Equalization Basin	\$6,150,000	3
	Subtotal Annual O&M Cost Avoided	\$27,604,416	
Tier 1 Wastewater Savings (input into the Financial Model)	Avoided Capital	\$557,447,915	Sum of items above
	Avoided O&M	\$27,604,416	
Tier 3 CEPT Related Savings (input into the Financial Model)	Avoided Capital	\$463,323,028	2
	Avoided O&M	\$12,986,956	

Notes:

- Savings do not include non-potable production during wet weather events.
- Pumping cost savings are for power savings only. Other O&M savings are not included.

= Key corresponding to related cost detail table and comparative figure

← see Attachment 2

← see Attachment 2

← see Attachment 2

Attachment 2. Point Loma Costs at Different Capacities

POINT LOMA PLANT COST SUMMARY	Recycled Water Study		Wastewater Master Plan w/Secondary	Avoided Costs	
	A	B	C	D	E
	143/320 MGD		240/413 MGD	Net 1	Net 3
	SECONDARY	CEPT Only	SECONDARY	Column C - Column A	Column A - Column B
CAPITAL COST					
Raw Construction (Labor, Mtl & Equip)	\$234,795,720	\$105,128,406	\$441,070,171	\$206,274,451	\$129,667,315
Other Cost	\$180,061,976	\$81,357,451	\$337,683,030	\$157,621,054	\$98,704,525
Contractor General Conditions					
Contractor OH/P					
Sales Tax					
Material Shipping and Handling					
Start-up, Training & Contr. O & M					
Construction Contingency					
Builders Risk, Liability & Auto Ins.					
Performance & Payment Bonds					
Construction Cost(Raw Construction + Other)	\$414,857,696	\$186,485,857	\$778,753,201	\$363,895,505	\$228,371,839
Soft Costs	\$165,943,079	\$74,594,343	\$311,501,281	\$145,558,202	\$91,348,736
COMNET					
Engineering, Legal and Administration					
Construction Management					
Subtotal (Construction + Soft)	\$580,800,775	\$261,080,200	\$1,090,254,482	\$509,453,707	\$319,720,575
Other Associated Projects					
Additional Power	\$39,504,836	\$0	\$67,390,602	\$27,885,766	\$39,504,836
Sludge Booster Pump Station Construction	\$0	\$0	\$1,206,059	\$1,206,059	\$0
Environmental Mitigation	\$2,323,814	\$2,323,814	\$2,323,814	\$0	\$0
Existing PSB Upgrades	\$104,097,618	included in estimate	included in estimate	N/A	\$0
TOTAL CAPITAL COST	\$726,727,042	\$263,404,014	\$1,161,174,957	\$434,447,915	\$463,323,028
ANNUAL O&M	\$18,842,645	\$5,855,688	\$37,497,060	\$18,654,415	\$12,986,957
Labor				1	2
Maintenance (@ 4% of Equipment Capital)					
Power (@ \$0.11/kWh)					
Chemicals					
Electrical & Instrumentation					

Notes:

(a) 320 mgd peak flow assumes 28 Mgal EQ Basin in place. \$13 mgd peak flow assumes 35 Mgal EQ Basin in place.

(b) Avoided includes all facilities associated with secondary treatment that is unnecessary if CEPT is allowed

Attachment 3. Comparison between Wastewater Master Plan and Recycled Water Study Facilities

	2011 Wastewater Master Plan W/ BIOLOGICAL AERATED FILTERS (BAF)	Recycled Water Study																						
POINT LOMA PLANT	<p align="center">PLWTP</p> <table border="1"> <thead> <tr> <th>BAF/Secondary</th> <th>Total</th> </tr> </thead> <tbody> <tr> <td>240 mgd ave</td> <td>240 mgd ave</td> </tr> <tr> <td>406 mgd peak</td> <td>413 mgd peak</td> </tr> </tbody> </table>	BAF/Secondary	Total	240 mgd ave	240 mgd ave	406 mgd peak	413 mgd peak	<table border="1"> <thead> <tr> <th>BAF/Secondary</th> <th>Total</th> <th>IPR</th> <th>AWPFs (varies):</th> </tr> </thead> <tbody> <tr> <td>143 mgd ave</td> <td>143 mgd ave</td> <td>5 mgd El Monte</td> <td>Harbor Drive</td> </tr> <tr> <td>243 mgd peak</td> <td>320 mgd peak</td> <td>68 mgd San Vicente</td> <td>North City</td> </tr> <tr> <td></td> <td></td> <td></td> <td>Mission Gorge</td> </tr> </tbody> </table> <p align="center"><i>73 mgd less pumping</i></p>	BAF/Secondary	Total	IPR	AWPFs (varies):	143 mgd ave	143 mgd ave	5 mgd El Monte	Harbor Drive	243 mgd peak	320 mgd peak	68 mgd San Vicente	North City				Mission Gorge
BAF/Secondary	Total																							
240 mgd ave	240 mgd ave																							
406 mgd peak	413 mgd peak																							
BAF/Secondary	Total	IPR	AWPFs (varies):																					
143 mgd ave	143 mgd ave	5 mgd El Monte	Harbor Drive																					
243 mgd peak	320 mgd peak	68 mgd San Vicente	North City																					
			Mission Gorge																					
SOUTH BAY PLANT	<p>SV08 Diversion 21 mgd ave 103 mgd peak = 57" Pipeline @9 ft/s max Velocity</p> <p>South Bay Plant Exsiting 15 mgd ave/Future 18 mgd Planned addl: 21 mgd ave/103 mgd peak</p>	<p>SV08 Diversion 47 mgd ave 133 mgd peak = 66" Pipeline @9 ft/s max Velocity</p> <p>South Bay Plant Exsiting 15 mgd average/Future 18 mgd Planned in Wastewater Master Plan: 21 mgd average/103 mgd peak Additional diverted in Recycled Water Study: 26 mgd average/30 mgd peak</p> <p>IPR 15 mgd Otay Lakes</p> <p>PS1 – 26 mgd less pumping</p>																						
<p>X = Wastewater Master Plan Project eliminated due to secondary treatment # = Item included in avoided cost tables</p>																								

Attachment 4. South Bay flows needed to produce reuse in Recycled Water Study

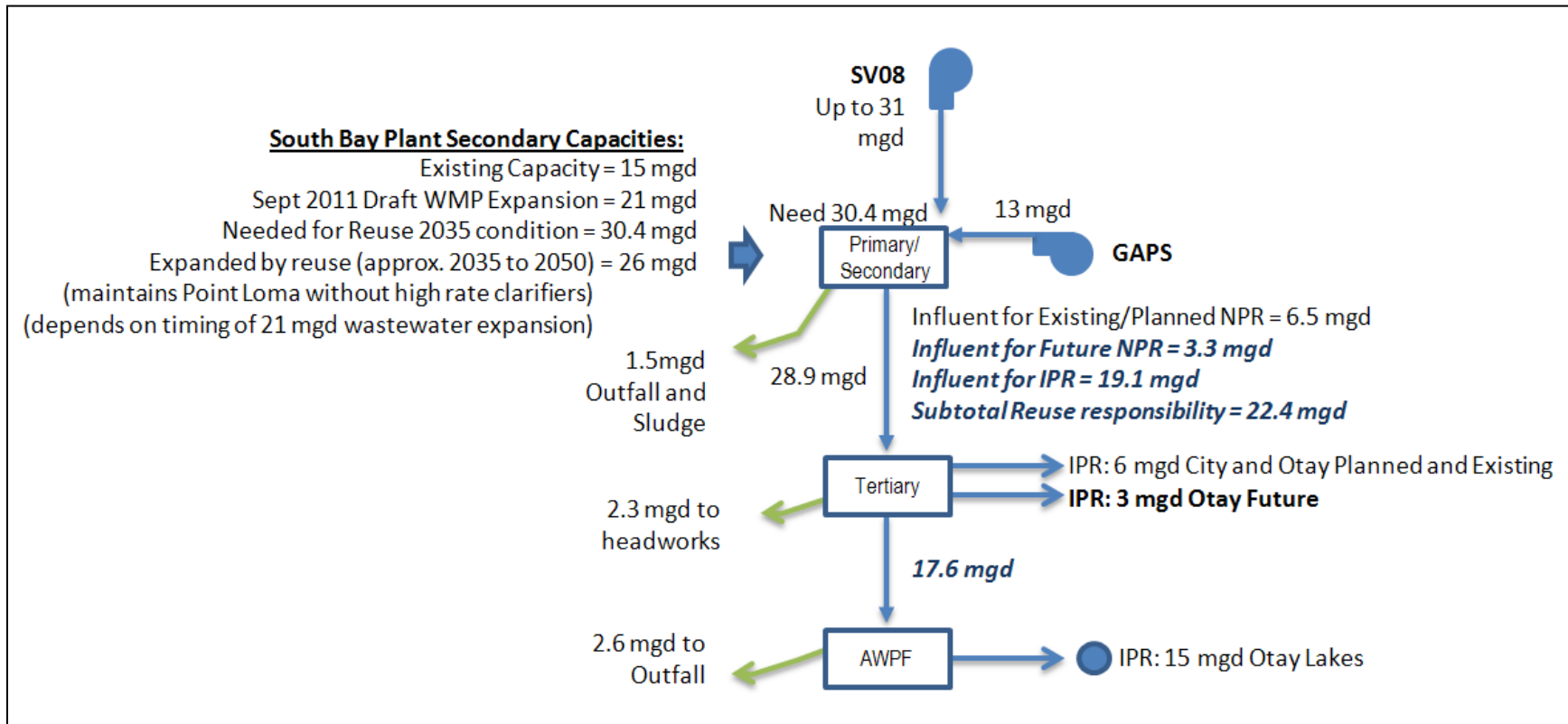

Notes:

- NPR = Non-potable recycled water; IPR = Indirect potable reuse; AWP = Advanced Water Purification Facility; GAPS = Grove Avenue Pump Station; WMP = September 2011 Draft Wastewater Master Plan
- Confirming the timing and final capacity needed for the South Bay 26 mgd expansion included in the Recycled Water Study is included as an Implementation Step. The planned 21 mgd expansion may provide enough secondary treatment to supply all the needed flows for reuse.

APPENDIX I: PARTICIPATING AGENCIES WHITE PAPER



This page intentionally left blank.

FLOW REDUCTIONS TO POINT LOMA WASTEWATER TREATMENT PLANT: OPTIONS OFFERED BY THE PARTICIPATING AGENCIES

September 2011

BACKGROUND

The Participating Agencies (PAs) of the City of San Diego (City) Metropolitan Wastewater System have been active participants in the City's Recycled Water Study. Representatives have attended both the Coarse and Fine Screening Sessions as well as participated in Stakeholder's meetings. Through this participation, the PAs have provided comments on alternatives that are expanded on in greater detail within this document. The PAs have also developed an understanding of the technical alternatives being addressed through the screening process, as well as the constraints placed on the Study, including budget, schedule and stakeholder expectations.

The PAs have provided the City with a White Paper (Paper) in July 2010 and a more recent revision of the white paper in March 2011, all prior to the release of the Draft Recycled Water Study Report (Draft Study) and attended the Draft Report Review Meeting (Review Meeting). At the Stakeholder Review Meeting, considerable time was spent on Section 8.5, Implementation Summary. We are requesting that this white paper be included as an Appendix to the final report and referenced in Section 8.5 as additional options to be considered and reviewed during future studies and/or the implementation process.

The technical staff for the PAs has reviewed the Technical Memorandums and Draft Study and provided comments to the City. Some of our comments have been integrated into the Study and several have not. Although we have participated in the study process, several of our concepts were not embraced due to lack of time, costs or available information in the Draft Study but nevertheless we feel are important to put forth as additional alternatives to consider when evaluating how to off-load flow to Point Loma Wastewater Treatment Plant (PLWTP) during the implementation process. Although estimated costs have not totally been developed for our alternatives, we submit that these alternatives might be less costly for the consumer, are alternatives that facilitate the expansion of recycled water (indirect potable reuse [IPR] and direct potable reuse [DPR]) usage on a regional basis while all the while supporting the Draft Study's purpose and approach, and could be implemented more quickly than the majority of the alternatives included in the Draft Study.

Various approaches exist for how flows are off loaded from PLWTP and how the water is reused. We believe that IPR and DPR remain viable long-term solutions that can provide additional local water supplies. Currently the Draft Study focuses primarily on Alternatives at the North City Water Reclamation Plant (NCWRP), Mission Valley or Pump Station 2 on Harbor Drive next to the airport along with the transportation of treated water to San Vicente Reservoir and to lesser extent alternatives that include diverting flow to East County and South Bay. We believe that our alternative should be explored in more detail as a part of a more regional solution to shaving flow from PLWTP.

ALTERNATIVES

Working within the parameters presented in the Study process, the PAs developed an alternative that offset flows from PLWTP that should have a lower financial impact on the rate

payers than the themes presented in the Draft Study. Although we have not developed costs for these alternatives, they originate from prior work on this Study, as well as other City and Padre Dam studies that have developed concepts and costs for many of the options.

We request that as part of the implementation process these alternatives be further developed and contrasted to other alternatives for North City and South Bay WRP's as part of the Study. Cost estimates should be developed for each individual facility (e.g. cost of Advanced Water Treatment (AWT) pipelines and facilities separate from treatment plant upgrades).

The PA alternative assumes that PLWTP can continue operating as a chemically enhanced advanced primary treatment (CEPT) facility or at a better level. This is based on the concept that the future discharge will still not harm the marine environment (as it does not harm currently.)

Figure 1, entitled "Metro TAC Alternative, Wastewater Offload from Pt. Loma" graphically illustrates our suggested alternative for future review during the implementation of the Recycled Water Study.

Figure 1

Metro TAC Alternative Wastewater Offload from Point Loma

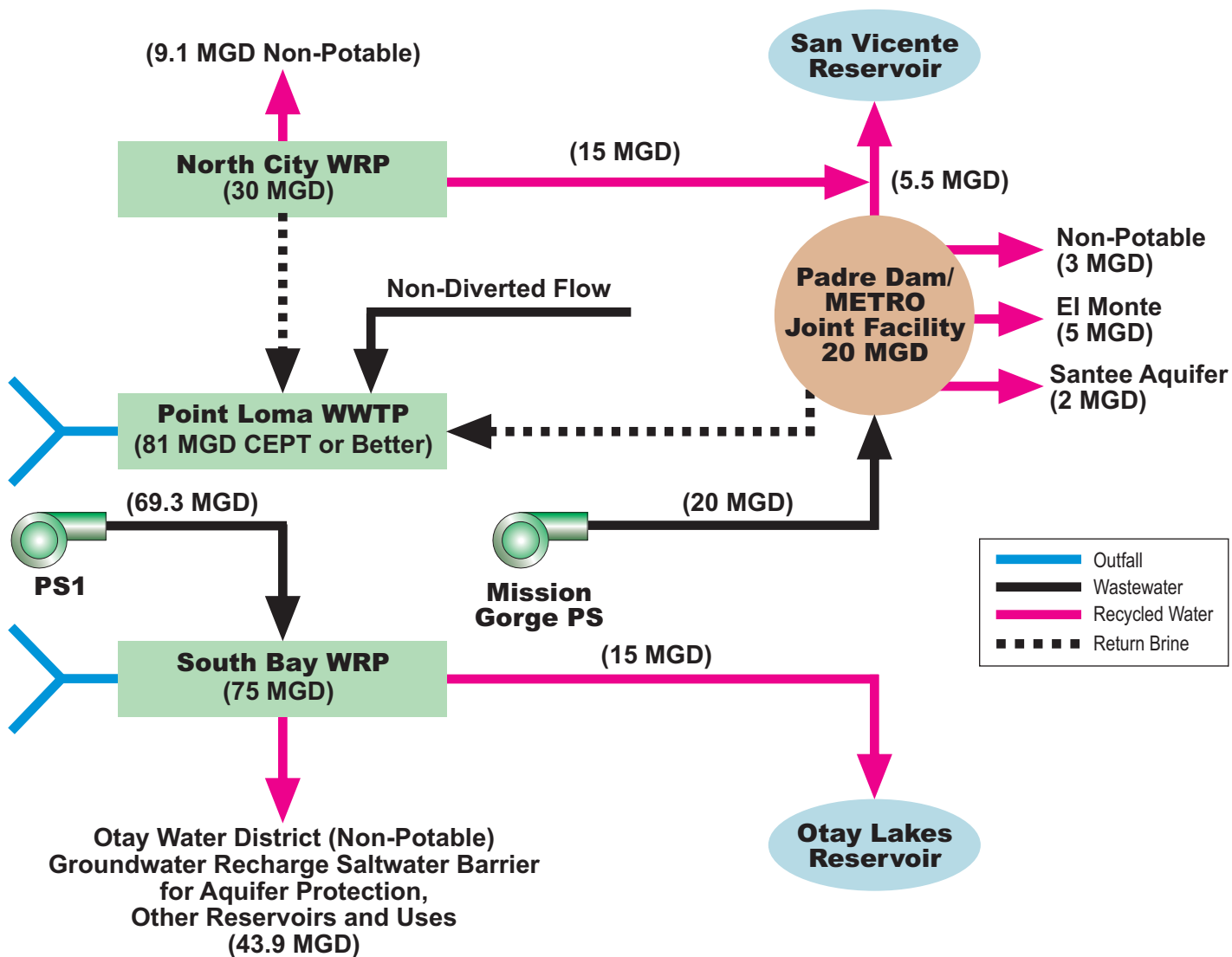

Offload		New/Existing Water	
Offset at Point Loma	in MGD		in MGD
NCWRP	30	NCWRP	24.1
PDMWD	20	PDMWD/ METRO	15.5
SBWRP	69	SBWRP	58.9
Total Offset	119	Total Offset	98.5
Required Treatment at PLWTP	81		

The alternative presented in Figure 1 includes the following approaches, arranged by treatment facility, as well as some general concepts.

Point Loma Wastewater Treatment Plant – Currently the operation of PLWTP, as an advanced primary treatment facility, comes very close to meeting the discharge requirements for a secondary treatment facility. Past studies and current monitoring indicates that the discharges do not negatively impact the marine environment. One option is to reduce the flows to PLWTP so that the discharge requirements meet the mass emissions secondary discharge requirements while staying with CEPT. The City, with the support of the PAs and other Stakeholders, would need to work with the regulators to permit the on-going operation of the plant as an advanced primary facility on a permanent basis. These negotiations should be occurring concurrently with the Water Purification Demonstration Project and the expected negotiations of State regulatory requirements for indirect potable reuse.

Based on projections in the Draft Study, the projected flow to be treated at PLWTP is expected to be 200 mgd (in the year 2035) this figure hasn't been totally vetted however it is the figure that we will base our assumptions on. To achieve a total suspended solids (TSS) mass emission rate for a smaller CEPT facility that could be equivalent to the mass emission rate of a secondary plant at the current PLWTP permitted capacity of 240 mgd, an offset of an average 100 MGD (based on an ultimate wastewater flows of 200 mgd) would be required at PLWTP, depending on the CEPT effluent quality.

The PAs Alternative assumes diverting more flow to the SBWRP and the Padre Dam/METRO Joint Facility to further enhance the CEPT process. As illustrated the PAs Alternative would divert 119 MGD away from PLWTP and meet or exceed this threshold.

North City Water Reclamation Plant – Instead of constructing new treatment facilities or conveyance facilities in the northern service area, expand Padre Dam's existing water recycling facility (PDWRF) to 20 mgd in appropriate phases utilizing the flows from El Cajon, Lakeside, and Alpine, as well as Santee. This would offload PLWTP as well as the East Mission Gorge Interceptor.

Shared City and PA facilities are not a new concept, especially when siting reclamation facilities. The City of Los Angeles is an active participant in the City's of Burbank's treatment plant. These facilities can provide much more cost effective alternatives by siting the reclamation facilities next to market demand.

There is an active, mature market for recycled water and ground water recharge in the East County with permitting already underway. In addition as opposed to Theme B-3¹ in the Draft Report PDWRF could be expanded on its existing footprint and no additional land would need to be acquired. Siting a new treatment plant on acquired land is a time consuming and expensive process. Included in Attachment A is a planning study dated May 17, 2010, presented to the Padre Dam Board of Directors by the District's Engineering Department. It discusses the expansion of the PDWRF in two phases, with the first being to 4.4 mgd.

¹ Theme B-3's included elements are maximizing the NCWRP at 30 mgd by serving existing and planned non-potable demands of 9.1 mgd and a North City indirect potable reuse project sized at 15 mgd, and a combination of a 46.0 mgd Harbor Drive Plant and a 6.8 mgd Mission Gorge Plant.

Padre Dam's facilities are closer to San Vicente and thus the pipeline costs will be reduced. As an interim measure prior to completion of the IPR facilities, the treated effluent from Padre Dam could be used for ground water recharge and the expansion of the recycled water market in the East County.

South Bay Water Reclamation Plant – The PA Alternative diverts the wastewater flows at PS1 (about 70 mgd) and would increase the treatment capacity of SBWRP to 75 mgd. This additional diversion would allow PLWTP's flow rating to be lowered to 81 mgd. Per Table 8-1 in the Draft Study this would provide the greatest cost benefit to the PAs and the City if secondary treatment would be required as conventional activated sludge treatment could be used. With the additional treated water from the 75 MGD plant IPR treated water could potentially be sent to other reservoirs in the region and used for ground water aquifer recharge. Once again full utilization of the SBWRF eliminates the need for the 50 mgd plant located on Harbor Drive next to the airport and/or the construction of a plant on the Qualcomm stadium property as suggested in the Draft Study Themes. The SBWRP has enough property to expand without additional land acquisition and is not in a potentially politically and/or environmentally sensitive area such as Harbor Drive, Qualcomm, and Fiesta Island.

It is our understanding that all of the South Bay Themes being prepared in the Draft Study include building a sludge pipeline from the SBWRP to PS1 and ultimately sending solids back to PLWTP. Alternatives to building a sludge pipeline should be explored particularly if sending solids to PLWTP could negatively impact the region's ability to continue operating PLWTP as a CEPT facility and do not aid in reducing the flows and the solids at PLWTP. Alternatives that could be explored include but should not be limited to siting solids handling facilities at the SBWRP and/or negotiating with the IBWC to handle the sludge produced by SBWRP. The IBWC (International Border and Water Commission) currently has an agreement with Mexico for disposal of its sludge which could be economically advantageous to the region. Such an agreement may also facilitate a new market for recycled water or IPR to Mexico.

The PAs Alternative includes 15 MGD of AWT treated water delivered to Otay Lakes Reservoir through a pipeline from the SBWRP which is similar to all Themes being advanced in the Draft Study. Additional alternatives should be explored that could be less costly in treatment and pipeline costs such as ground water recharge of several aquifers including Tijuana River Valley, Spring Valley, and San Diego aquifers. According to a San Diego County Water Authority study by Boyle Engineering, titled *San Diego Formation Aquifer Storage and Recovery Study, Phase 1*, annual extraction capacities for the San Diego formation have been calculated to be between 40,000 AFY to 90,000 AFY. These were preliminary studies but further assessment of the potential for groundwater recharge should be pursued as part of the implementation of the Draft Study. The largest demand for water in the region could be right next to the SBWRP in Tijuana. There could be opportunities to explore that could facilitate METRO's service area needs with that of our neighbors and taking advantage of both the SBWRP and IBWC plant in this area. Ground water recharge is a large portion of the successful Orange County Water Agencies project which supplies 500,000 Orange County residents with drinking water annually. In contrast to IPR, the regulations and permitting processes for groundwater recharge are vetted and in place.

The PA Alternative diverts the wastewater flows at PS1 (about 70 mgd) and would increase the treatment capacity of SBWRP to 75 mgd. This additional diversion would allow PLWTP's flow rating to be lowered to approximately 80 MGD. Per Table 8-1 in the Draft Study this would provide the greatest cost benefit to the PAs and the City if secondary treatment would be required as conventional activated sludge treatment could be used. With the additional treated

water from the 75 MGD plant IPR treated water could be potentially be sent to other reservoirs in the region and used for ground water aquifer recharge. Once again full utilization of the SBWRF eliminates the need for the 50 mgd plant located on Harbor Drive next to the airport and/or the construction of a plant on the Qualcomm stadium property as suggested in the Draft Study Themes. The SBWRP has enough property to expand without additional land acquisition and is not in a potentially politically and/or environmentally sensitive area such as Harbor Drive, Qualcomm, and Fiesta Island.

SUMMARY AND INTERIM MEASURES

While IPR is a desirable outcome and was thoroughly examined in the Recycled Water Study, we feel that the City should investigate the expansion of its recycled water program from a cost to construct and operate as well as a timing basis. The Draft Study states that IPR will take between a minimum of 8 to 10 years to implement.

By implementing other alternatives sooner than IPR to a reservoir, PLWTP flow offsets can occur sooner and additional recycled water could be produced, thereby increasing the use of this precious resource during the planning and construction of the IPR facilities. This would also allow the Region to diversify its water portfolio during this period of time.

Using this concept, the City should start with the lowest cost water to produce which is currently recycled water. We understand the reluctance on the City's part to expand its purple pipe system but additional recycled water could be sold from the North City and South Bay plants to wholesale customers.

Negotiations with wholesale entities in the North Service area that are requesting recycled water should be started now. The agreements with wholesale customers could be as simple as to provide recycled water until the IPR facilities are in place. In discussions with agencies other than the PAs, we understand that while there is pent-up demand to purchase recycled water purchases, City staff will not discuss expanding recycled water services even to existing wholesale customers where no additional capital cost need be incurred by the City. This is disconcerting because this means that recycled water sales are being artificially capped and valuable revenue and CWA/MWD credits are being lost.

In addition, each year the PAs and the City of San Diego's wastewater customers share in the cost of return to sewer flow approximating 18 MGD. Return flows are not only process water and centrate (which we are not objecting to since centrate must always be discharged) but flows that are treated once at NCWRP and then again at PLWTP. This costs the PAs as well as the City's wastewater customers in excess of \$1 million per year that could be better spent elsewhere. The reduction of these return flows should be a primary goal of implementation process as this would automatically reduce flows to PLWTP of between 18 to 20 MGD. If more recycled water was produced at NCWRP these return flows would decrease. Additionally, treatment costs may decrease because the cost to treat flows to tertiary at NCWRP and generating revenue from the commodity is less expensive than treating secondary treated flows discharged from NCWRP to advanced primary quality at PLWTP and are therefore being treated twice.

In the South Bay the City could quickly begin creating more recycled water, and divert flows from PLWTP, by building either the Salt Creek diversion structure or the CV14 diversion structure to provide the current seasonal recycled water to the South Bay market. The current

South Bay flow cannot meet peak summer demands. This would take between 3 to 6 MGD off of PLWTP in the near future.

In addition, the City should immediately start planning for the diversion of flows at least SV8 and solids handling facilities at SBWRP, as envisioned by the Recycled Water Study and the City's last wastewater master plan, as the land and the permitting is already in place. Maximizing the SBWRP permanently offloads PLWTP as the plant has its own outfall with plenty of capacity if needed.

Once the production of recycled water is maximized at both plants then the least costly alternative(s) should be developed. Creative options such as the ones contained in this Paper should be developed and studied to provide for the most cost effective solution for the region while creating new water supplies that will benefit both the City and the region as a whole.

Attachment A

Engineering Report – Padre Dam Water Recycling Facility Expansion to 4.4 MGD

ENGINEERING REPORT

PADRE DAM WATER RECYCLING FACILITY

EXPANSION TO 4.4 MGD

May 17, 2010

Prepared by:
Al Lau, P.E.
Arne P. Sandvik, P.E.

This page intentionally left blank.

TABLE OF CONTENTS

1. Introduction
 - 1.1 WRF Expansion Objectives
 - 1.2 Background
 - 1.3 Relevant Studies
2. Project Description
3. Recycled Water Demand
 - 3.1 Current and Future Demand Projection
 - 3.2 Seasonal Variation of Recycled Water Demands and Seasonal Storage
4. El Monte Valley Groundwater Recharge and River Restoration Project
5. Project Costs
6. Funding Sources
7. Financial Feasibility Analysis
 - 7.1 Net Present Worth Analysis
 - 7.2 Sensitivity Analysis
 - 7.3 Breakeven Analysis
8. Regulatory Issues
 - 8.1 California Environmental Quality Act (CEQA)
 - 8.2 State Discharge Requirements
 - 8.3 State Department of Health Requirements
 - 8.4 City of Santee Conditional Use Permit
9. Schedule
10. Recommendations

List of Figures

Figure 1 Proposed Site Plan for Expansion to 4.4 mgd

List of Tables

Table 1. Summary of Additional Recycled Water Users
Table 2. Potential New Recycled Water Customers Sorted by Availability of Facilities
Table 3. Advanced Water Treatment Flow Available to the El Monte Valley Groundwater and River Restoration Project
Table 4. Summary of Project Costs
Table 5. Planning Level Construction Costs for Plant Expansion and/or Additional Seasonal Storage
Table 6. Net Present Value (NPV) Summary Table
Table 7. Summary of Design Costs

Attachments

A. System Demands and Seasonal Storage
B. El Monte Valley Recharge Phased Project
C. Yearly Rate Increases, with No WRF Expansion

List of Acronyms

<u>Acronym or Phrase</u>	<u>Meaning</u>
AAD	average annual demand
AF, AFY	acre-feet, acre-feet per year
ARRA	American Reinvestment and Recovery Act
AWT, AWTP	advanced water treatment, advanced water treatment plant
BOR	Department of Interior, Bureau of Reclamation
CEQA	California Environmental Quality Act
CUP	Conditional Use Permit issued by the City of Santee
DHS	Department of Health Services
DWR	California Department of Water Resources
El Monte, EMVRP	El Monte Valley, El Monte Valley Recharge Project
High Rating Study	Feasibility Study for High Rating the Santee Water Reclamation Facility, prepared by Black & Veatch, March 2006.
Helix, HWD	Helix Water District
IPS	Influent Pumping Station
LISA 1, 2	Local Investigations and Studies Assistance program, Phase 1 and Phase 2 respectively. Provides grants from the San Diego County Water Authority.
MBR	Membrane Bioreactor
METRO	City of San Diego Metropolitan Wastewater Department
mgd	million gallons per day
MND	Mitigated Negative Declaration
MWD	Metropolitan Water District of Southern California
NEPA	National Environmental Policy Act
NPDES	National Pollutant Discharge Elimination System
NPV	net present value
Padre Dam, PDMWD	Padre Dam Municipal Water District
PS	pump station
RFP	Request for Proposal
SDCWA	San Diego County Water Authority
Title XVI	Title XVI of the Reclamation Projects Authorization and Adjustment Act of 1992.
Title 22	Title 22 of the California Code of Regulations
WRF	Water Recycling Facility
WSA	Western Service Area - PDMWD
WWTP	Wastewater Treatment Plant

This page intentionally left blank.

1.0 Introduction

The Padre Dam Municipal Water District (Padre Dam) operates a Water Recycling Facility (WRF) located in the northern portion of the City of Santee, San Diego County, California. The proposed WRF Expansion project would expand the capacity of the existing WRF, which converts wastewater generated within Padre Dam's Western Service Area (WSA) into Title 22 tertiary treated recycled water. The tertiary treated recycled water is then used to maintain the water levels of the Santee Lakes or delivered to customers, who primarily use it for landscape irrigation.

Currently, the WRF is having difficulty meeting recycled water demands during the summer months and in some years have had to supplement the recycled water system using a District-owned groundwater well. During the summer peak months, the Santee Lakes have also experienced water quality issues because they draw replenishment water from the oxidation ponds. The water in the oxidation pond, in general, is of lower quality because of water age. As the ponds empty, the water quality may degrade to a point to cause low dissolved oxygen level and resulting in adverse impacts to aquatic life in the lakes.

The purpose of this engineering report is to serve as a briefing document for Padre Dam staff, management team, and Board of Directors to facilitate making a decision to proceed with design of an expansion of the WRF to 4.4 mgd.

This document has been updated from the March 24, 2010 by modifying the financial analysis to reflect a reduced cost to treat wastewater at METRO due to sludge over-billing and reduced loading of suspended solids and chemical oxygen demand due to incorporation of In-Pipe Technology. The financial analysis was also updated to reflect the most recent estimates of the future rates for the sale of recycled water.

1.1 WRF Expansion Objectives

The objectives of the proposed project include:

1. Increase production of recycled water thereby providing an alternative source to reduce the use of potable water for irrigation. This would be accomplished by expanding the capacity of the existing WRF from 2.0 million gallons per day (mgd) to 4.4 mgd by installing additional conventional treatment facilities.
2. Maintain a high quality of treated water in order to meet regulatory standards for live stream discharge and continuing to meet water quality objectives for the Santee Lakes Recreational Facility.
3. Evaluate the potential to install an Advanced Water Treatment Plant (AWTP) on-site to send highly treated recycled water to a groundwater recharge and reclamation project such as Helix's El Monte Valley Recharge project (EMVRP).

1.2 Background

Padre Dam provides wastewater treatment and recycled water production services at its WRF located at the northerly end of the Santee Lakes. The original WRF was constructed in the early 1950's by the Santee County Water District for the purpose of providing sewer treatment to local development. In the early 1960's, the Department of Health approved the use of the lakes for recreation and fishing. A new water recycling facility was constructed in 1968, which was upgraded and expanded to its current form in 1997. The 1997 expansion included construction of a system of distribution pipelines within the City of Santee to supply recycled water to individual customers for landscape irrigation.

The existing WRF is a scalping plant (does not have the ability to treat solids) with a permitted treatment capacity of 2.0 mgd. The remainder of the wastewater generated in the WSA is treated at the City of San Diego Metropolitan Wastewater Department's (METRO) Point Loma Wastewater Treatment Plant (WWTP). The WRF produces tertiary treated recycled water that meets the requirements for reuse as specified in Title 22 of the California Code of Regulations. The recycled water is currently delivered to over 200 customers, mostly within the City of Santee, and is used primarily for irrigating landscape for schools, street medians, and other commercial and residential users.

1.3 Relevant Studies

Previous and concurrent studies performed with regard to expanding the WRF are summarized below:

- Feasibility Study for High Rating the Santee Water Reclamation Facility, Black & Veatch, March 2006. This study evaluated expansion of the plant from 2 mgd to one of the following capacities: 2.7 mgd, 4.0 mgd or 5.4 mgd. This study concentrated on serving recycled water customers within the Padre Dam service area and did not consider providing Advanced Water Treatment (AWT) for water sent to the El Monte Valley Recharge Project (EMVRP).
- El Monte Valley Recharge Project Feasibility Study - Helix completed this study in April 2006. The study evaluated the general feasibility of using advanced treated water for aquifer recharge.
- Feasibility Study for Padre Dam WRF Expansion as it relates to serving recycled water demand (Title 22 water) and providing AWT water for the EMVRP. A draft report has been completed showing options and costs for expanding the WRF to 4.4 mgd in Phase 1, then to 10 mgd in Phase 2.
- Draft Financial Feasibility Study for Padre Dam WRF Expansion as it relates to serving recycled water demand (Title 22 water) and providing AWT water for the EMVRP. A draft final report has been completed to evaluate financial feasibility to expand the WRF utilizing (1) Net Present Value, (2) Break-Even Analysis, and (3) Return on Investment methods.
- Draft Feasibility Study for Seasonal Storage.
- Draft Feasibility Study for Santee Lakes Water Quality Modeling Study.
- Draft Influent Flow Equalization Evaluation Study.
- Draft Headworks Evaluation Study.
- Draft UV Disinfection Alternative Evaluation
- Other National Pollutant Discharge Elimination System (NPDES) permit related studies.

2.0 Project Description

The first phase of the WRF expansion (from 2.0 to 4.4 mgd) would allow additional recycled water to be provided to the customers within the Padre Dam's WSA, which would reduce overall potable water use consumption within the District. Additionally, the first phase of the WRF expansion would have an option to include an AWTP that includes micro-filtration, reverse osmosis and advanced oxidation processes to produce highly purified water suitable for use in an indirect potable reuse project, such as the EMVRP proposed by the Helix Water District.

In addition to the AWTP, the engineering documents, partially funded by the LISA Grant Funding Program addressed the potential for a future Phase II expansion which could increase the capacity from 4.4 to 10.0 mgd if the EMVRP is proved capable of taking addition advanced treated water from the WRF. The proposed expansion from 2.0 to 4.4 mgd would be designed such that it would not preclude this possibility of expansion to 10 mgd.

Currently, the AWTP is an optional expansion task pending on the successful negotiation with Helix on the price of the advanced treated water. The design of the AWTP and pump station

(PS) would not commence unless Helix is committed to purchase the advanced treated water from the District. The costs of conveying the advanced treated water and onsite spreading facilities would be provided by Helix. The lead agency for the environmental review and documentation associated with the EMVRP is Helix.

The first phase of the WRF expansion project will mirror the existing conventional treatment processes at the existing WRF. Utilizing conventional treatment processes to convert wastewater into Title 22 tertiary treated recycled water is the preferred alternative because it is considerably less expansive than utilizing the membrane bio-reactor (MBR) technology. Additionally, Helix prefers conventionally treated water for its EMVRP because it would be more readily accepted by Department of Health Services (DHS). The proposed site plan for this expansion is shown in **Figure 1**.

Major project elements include the following:

1. Pump upsizing at the existing Influent Pump Station (IPS).
2. New headworks facility to remove grit and rags (either near the influent pump station or at the WRF).
3. Flow equalization basins (included in environmental documents, but not planned for design or construction as recent construction of the Cottonwood Diversion should prove that flow equalization basins at the WRF are not needed).
4. New primary clarifiers.
5. Addition of aeration/mixing equipment to Train 2 of the existing Bardenpho basins.
6. New secondary clarifier.
7. New tertiary flocculation sedimentation facility.
8. New tertiary biological polishing filters.
9. New chlorine contact basin and/or disinfection facility.
10. New AWT Facility, if an agreement is reached with Helix.

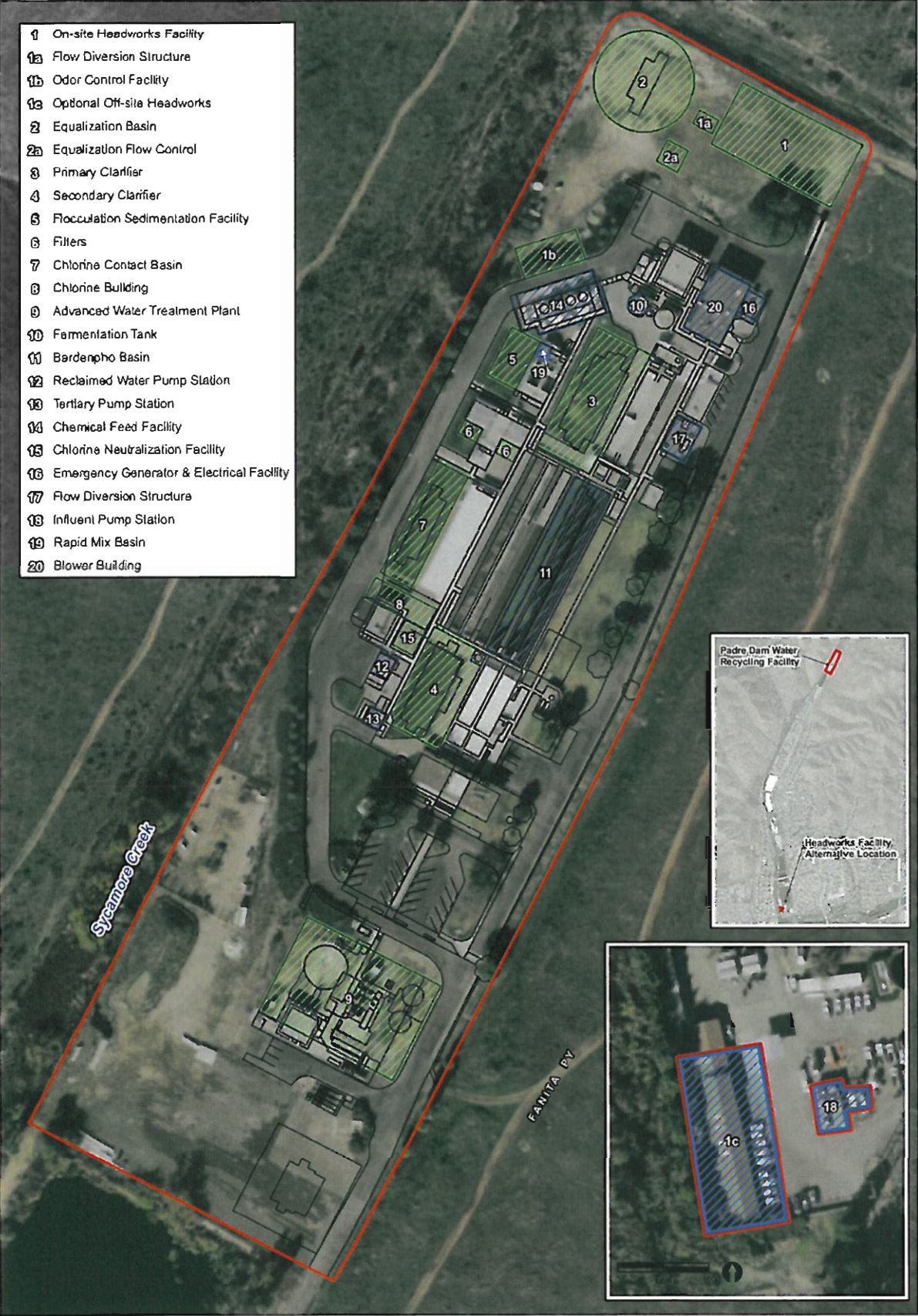

- 1 On-site Headworks Facility
- 1a Flow Diversion Structure
- 1b Odor Control Facility
- 1c Optional Off-site Headworks
- 2 Equalization Basin
- 2a Equalization Flow Control
- 3 Primary Clarifier
- 4 Secondary Clarifier
- 5 Flocculation Sedimentation Facility
- 6 Filters
- 7 Chlorine Contact Basin
- 8 Chlorine Building
- 9 Advanced Water Treatment Plant
- 10 Fermentation Tank
- 11 Bardenpho Basin
- 12 Reclaimed Water Pump Station
- 13 Tertiary Pump Station
- 14 Chemical Feed Facility
- 15 Chlorine Neutralization Facility
- 16 Emergency Generator & Electrical Facility
- 17 Flow Diversion Structure
- 18 Influent Pump Station
- 19 Rapid Mix Basin
- 20 Blower Building

4 OF 19

Project Boundary
 Site Plan
 New Facility
 Modification

0 Feet 100

FIGURE 1
Site Plan – Conventional Treatment Alternative

3.0 Recycled Water Demand

3.1 Current and Future Demand Projection

Currently the demand for recycled water includes the Santee Lakes/Ponds and irrigation users. The lake and ponds have been receiving approximately 1 mgd average annual demand (AAD) which includes consumptive use and discharges to Sycamore Creek (flushing). The Santee Lakes demand could be higher if Padre Dam chooses to enhance the lakes' water quality. The current AAD recycled water demands are approximately 0.8 mgd. Increased recycled demand is anticipated in the following categories of users:

TABLE 1
SUMMARY OF ADDITIONAL RECYCLED WATER USERS

Identified Customers by Category	AAD Identified (mgd)	Cumulative Additional AAD Demand
A. Future Customers Near Existing Recycled Water Lines	0.088	0.088
B. Existing Customers Using Potable Water for Irrigation, located near Existing RW Lines	0.092	0.180
C. Future Customers Serviced with \$1.3M of New RW Lines	0.178	0.358
D. Carlton Oaks Golf Course 6 Months of Winter Flow	0.370	0.728
E. Customers Requiring More Extensive Facilities to Serve or Timing of Development is Highly Questionable.	1.178	1.906
F. Willowbrook Golf Course.	0.500	2.41

A detailed list of users in each category is presented in Table 2.

User categories are further defined as follows:

Category A - Future Customers Near Existing Water Lines. These developments are currently planned or recently connected to the system and are located adjacent to existing recycled waterlines. Use of recycled water can be accomplished at little or no cost to Padre Dam. Three customers listed in this category were connected to the system in 2009: (1) Market Place at Santee, (2) Speer Field and (3) Forrester Creek Irrigation System.

TABLE 2
Potential New Recycled Water Customer Sorted by Availability of Facilities

ID #	Name of Potential New Customer / Developer	Estimated Time Online (Year)	Projected Average Usage (GPD)	Projected Average Usage (Ac-ft / YR)	Notes
A. Customers Near Existing Recycled Water Lines					
3	Riverwalk	2010	8,035	9.0	(1)
4	Santee Elementary School (MG Site)	2015	3,839	4.3	(1)
5	Caltrans Route 52	2012	6,071	6.8	(1)
9	Las Brisas	2010	982	1.1	(1)
11	Town Center Community Park Phase 2 - Sports Park	2010	14,373	16.1	(1)
13	Mission View Estates	2011	6,720	7.5	(1)
14	West Hills and Mast Commerical	2015	5,760	6.5	(1)
16	Chat Harriett Elementary	2010	8,160	9.1	(1)
21	WalMart Expansion	2011	960	1.1	(1)
25	Cajon Park Elementary - Ball Fields	2012	14,880	16.7	(1)
34	Marketplace @ Santee	2009	7,200	8.1	(1)
35	Weld Blvd Commerical Dev.	2015	4,320	4.8	(1)
36	Speer Field	2009	3,360	3.8	(1)
37	Mamokal	2011	2,400	2.7	(1)
40	Forrester Creek Irrigation System	2009	0	0.0	(1)
	Santee Street Cleaning	2011	714	0.8	(1)
	Sub-Total		88,000	98	
B. Existing Irrigation Users Using Potable Water, Located Near Existing RW Lines			92,000	103	
C. Customers Serviced by \$1.3M WL Construction Project					
1	Edgemoor Business Park	2011	6,785	7.6	(2)
2	Edgemoor Hospital	2010	7,945	8.9	(2)
10	Sycamore Landfill	2010	119,985	134.4	(2)
15	Carlton Oaks School	2015	7,200	8.1	(2)
18	Sycamore Canyon Elementary	2015	5,280	5.9	(2)
19	Carlton Hills School	2009	12,000	13.4	(2)
20	Las Colinas	2013	14,400	16.1	(2)
31	County - Condos - Cottonwood West	2015	4,320	4.8	(2)
	Sub-Total		178,000	199	
	Sub-Total Categories A thru C		358,000	400	
D. Carlton Oaks Country Club (6 months of winter demand)					
7	Carlton Oaks Country Club (6 months of winter demand)	2011	370,000	414	
E. Customers Requiring Extensive Facilities to Service or Timing of Development is Highly Questionable.					
Existing Irrigation Users Using Potable Water					
6	Castle Rock	2015	74,098	83.0	(3)
8	Fanita Ranch	2025	699,017	783.0	(3)
12	Olsen Group Condos (N3)	2015	960	1.1	(3)
17	Christ the King Church - Mesa Rd	2010	1,920	2.2	(3)
22	Hill Creek Elementary	2015	14,880	16.7	(3)
23	Meadowrun	2015	4,800	5.4	(3)
24	Hillside Meadow	2015	11,520	12.9	(3)
26	Mast Business Park - Near Riverford Road	2015	3,360	3.8	(3)
27	Riverside Dr. Business Park	2015	9,120	10.2	(3)
29	Cuyamaca Development 1 (North of Silver Country Est.)	2015	6,240	7.0	(3)
30	Cuyamaca Development 2 (North of Silver Country Est.)	2015	12,960	14.5	(3)
32	County - Condos - Cottonwood East	2015	4,320	4.8	(3)
33	Drive-in Commerical Development	2015	4,320	4.8	(3)
38	Mission Villa Estates	2011	480	0.5	(3)
39	Cajon Speedway	2015	21,600	24.2	(3)
	Sub-Total		1,178,000	1319	
F. Willowbrook Golf Course					
28	Willowbrook Golf Course	2025	500,000	560.0	(3)
	Total		2,406,000	2,693	

Used 15% of total project acreage to determine irrigated area of unknown subdivisions.
 Assumed 10,000 sq feet = 480 gpd for drought tolerant planting
 Assumed 5,000 sq feet = 480 gpd for turf

- Notes:
- (1) Customers Near Existing Recycled Water Lines
 - (2) Customers Serviced by \$1.3M WL Construction Project
 - (3) Customers Requiring Extensive Facilities to Service or Timing of Development is Highly Questionable.

Category B - Existing Customers Using Potable Water for Irrigation, Located Near Existing Recycled Water Lines. These users have separate meters for their domestic (in-house) use and their outside irrigation use. They are currently using potable water for both their domestic and outdoor irrigation uses. The demand for this category of user is well documented and is based on existing meter records. There will be some cost of retrofitting the existing irrigation system from using potable water to recycled water. The average cost of the conversion to recycled water is estimated to be \$17,500 per user.

Category C - Future Customers Serviced with \$1.3 Million of New Recycled Waterlines. Customers in this category are not adjacent to existing recycled lines but can be reached for fewer construction dollars per unit of demand than customers in Categories E and F and therefore represent a quicker return on the investment. Included in this Category is the Sycamore Landfill which represents the largest user (67 percent of the total demand for Category B).

Category D - Carlton Oaks Country Club. The golf course currently irrigates with groundwater using on-site wells. During peak summer demands, low groundwater levels are causing production rate problems for the golf course. The golf course is interested in using recycled water during the winter months to keep their groundwater in reserve for use during the peak summer months. However, the golf course is only interested in using recycled water if the District adopts a seasonal discount for recycled water. For planning purposes, it is assumed that the golf course would use one half of their typical water use during the winter months.

Category E - Customers Requiring More Extensive Facilities to Serve or Timing of Development is Highly Questionable. The two largest users in this category are the Castlerock and Fanita Ranch developments and have had a history of delays and setbacks. These two users comprise approximately 89 percent of the total demand in this category.

Category F - Willowbrook Golf Course. Willowbrook Golf Course is an existing nine hole course located in the easterly portion of Padre Dam's Western Service area. The current source of water used for golf course irrigation is either well water similar to Carlton Oaks Golf Course or potable water from Lakeside Water District. The golf course does lie within Padre Dam's Western Service area for sewer service and therefore could potentially be served using recycled water produced by Padre Dam.

Process water needed for treatment process for the Cable Ski Park is not included in the numbers above because the magnitude of this demand has not yet been determined. It will be several years before the Cable Ski Park demand will be realized.

3.2 Seasonal Variation of Recycled Water Demands and Seasonal Storage

Recycled water demands vary considerably during the year with the summer months having higher demand than the winter months. Should peak summer demands exceed the plant recycled water production capacity, the shortage of water must come from any combination of seasonal storage, well water and/or potable water. Monthly variation in recycled water for each demand category is presented in Attachment A.

An analysis was performed to show the seasonal storage needs for each demand category. It was assumed that no water was supplied by either Padre Dam's well or the potable water system. Tables located in Attachment A show the amount of seasonal storage required for each of the demand categories and different treatment plant sizes.

If the treatment plant is not expanded, there would be a need to expand the existing seasonal storage by approximately 63 MG just to keep up with existing demand and not supplement with well or potable water. One of the major reasons the additional storage is needed is to provide flushing of the lakes during the summer months (0.35 mgd flushing).

If the WRF were highrated to 2.7 mgd influent capacity, Category A customers could be served without addition to seasonal storage. Category B could be served with an addition of only 14 MG. To serve Category C, 43 MG of storage would need to be constructed.

With a 4.4 mgd influent treatment plant, additional seasonal storage would not be necessary until Category E was added.

4.0 El Monte Valley Groundwater Recharge Mining and River Restoration Project

In April 2006, Helix completed a study that analyzed the possibility of utilizing highly purified recycled water to recharge a groundwater basin in El Monte Valley. This project was to have the dual benefit of raising the groundwater level to support habitat restoration and then extracting groundwater to provide new raw water to supply the R.M. Levy Water Treatment Plant. This project could have numerous benefits to the local community including creating a recreational area for local residents, restoring natural habitat, improving the water quality in the El Monte Groundwater Basin, and expanding the local water portfolio by providing a new water supply.

The study examined the overall feasibility of the project including: 1) potential treatment processes needed to purify water prior to entering the groundwater basin; 2) the potential yield of the groundwater basin; 3) strategies for raising the groundwater table; 4) pipeline alignments from purified water sources to the El Monte Valley; and 5) funding opportunities for the project. Based on the preliminary modeling performed to date, it appears that, with careful management, the basin can support over 5,000 acre-feet per year (AFY) of recharge and extraction during normal operation.

Padre Dam was approached as the preferred source of the recycled water. Staff participated in reviewing and providing feedback throughout the study, and simultaneously analyzed the feasibility of providing 5,000 acre-feet per year of advanced treated recycled water (approximately 4.5 mgd). This would be a year-round demand and opportunity to treat and dispose of all wastewater generated within the District. Padre Dam would even need to import wastewater from the County Sanitation District to meet the ultimate demand.

The project would require Padre Dam to expand the WRF to 8 to 10 mgd in order to provide the 4.5 mgd of advanced treated recycled water in addition to providing Title 22 treated recycled water to our existing customers and the lakes. Additional advanced treatment facilities would need to be constructed to provide microfiltration, reverse osmosis, advanced oxidation utilizing hydrogen peroxide and ultraviolet radiation, and lime for pH adjustment. A purified water pipeline approximately 12 miles long from the WRF to the El Monte groundwater basin would also have to be constructed. Facilities would also be needed to convey more raw wastewater flow to the treatment plant including diversion structures, wastewater collection and influent pump station upgrades. Spreading grounds and extraction wells would also have to be constructed in the El Monte Valley to provide the groundwater recharge and collect the new raw water.

Helix's Feasibility Study for the El Monte Valley Recharge Project estimated that the total project cost would range between \$64M and \$153M, with a large part of that cost needed to expand the WRF and construct advanced treatment facilities. Part of this cost was anticipated to be funded by the sale of sand that would be mined from the El Monte Valley during the river restoration and in combination of selling treatment capacity at the Point Loma WWTP. There

is also a great potential for grant funding and regional participation that has caused Padre Dam and Helix to continue to pursue this opportunity.

The proposed WRF expansion to 4.4 mgd (tertiary) proposed will generate 2 mgd (2,240 AFY) of advanced treated water and will be constructed in a configuration that will allow a further expansion to 10 mgd and upgrade to advanced treatment in a subsequent phase. When complete, the ultimate benefits of these combined projects will include 4.5 mgd (5,000) AFY of advanced treated water for the El Monte Project and a reduction in the amount of future capacity upgrades that will be necessary at the Point Loma WWTP.

Table 3 shows the demands anticipated for the EMVRP. The project is currently estimated to have a maximum hydraulic capacity of 4.5 mgd (5,000 AFY). Helix has planned three phases for the EMVRP. This is shown in graphical form in **Attachment B**. Each phase has a different blend of AWT to raw water. In Phase 1, the Department of Health will only allow the AWT water to be 25 percent of the total flow sent to the aquifer and the DHS will limit the hydraulic detention time to one year (or 1.125 mgd of AWT water). The other 75 percent would most likely be raw water supplied by Helix. Once the hydraulics prove there is more than a six month travel time and no short-circuiting in the aquifer, then the percentage of AWT water can be increased with Health Department approval.

There will be seasonal variation associated with the amount of AWT water that Padre Dam can send to the EMVRP. **Table 3** shows the variations in flow that a plant expansion to 4.4 mgd influent could send to the EMVRP. As shown in the table, as more categories of demand are added within the District, less AWT water is available. The expansion to 4.4 mgd can provide up to 2.37 mgd during the winter months for all of the demand except Categories E and F. For Categories E and F, the summer demands for Title 22 water customers is so high that the AWT water available falls to zero. The average AWT water available when Categories E and F are added would not be acceptable for the EMVRP project.

TABLE 3
AWT Water Available to the EMVRP
4.4 mgd Treatment Plant
Total Lake/Pond Demand Including Flushing = 1.00 mgd
Lake/Pond Consumptive Use = 0.65 mgd, Flushing = 0.35 mgd

A. EMVRP AWT WATER USE NEEDS

Maximum Hydraulic Capacity Currently Estimated for the EMVRP = 4.5 mgd (5,000 AF/Yr)

	Ratio of AWT Water to Raw Water (Blend)						
	50%	60%	70%	75%	80%	90%	100%
AWT Flow MGD	2.25	2.7	3.15	3.375	3.6	4.05	4.5

B. WRF PRODUCTION - 4.4 MGD Influent

	EXISTING DEMAND			CATEGORY A - Demand by Existing WL's			CATEGORY B - Potable Irrig Users Near (E) WL's			CATEGORY C - Demand by \$1.3M of new WL's		
	Min	Max	Ave	Min	Max	Ave	Min	Max	Ave	Min	Max	Ave
Raw Influent	4.4	4.4	4.4	4.4	4.4	4.4	4.4	4.4	4.4	4.4	4.4	4.4
% Loss Thru Conventional Treatment	10%	10%	10%	10%	10%	10%	10%	10%	10%	10%	10%	10%
Title 22 Output	3.96	3.96	3.96	3.96	3.96	3.96	3.96	3.96	3.96	3.96	3.96	3.96
PD Demands	0.92	2.65	1.79	0.97	2.79	1.88	1.03	2.94	1.97	1.17	3.15	2.15
Remaining RW	3.04	1.31	2.17	2.99	1.17	2.08	2.93	1.02	1.99	2.79	0.81	1.81
% Loss Thru Advanced Treatment	15%	15%	15%	15%	15%	15%	15%	15%	15%	15%	15%	15%
AWT Output	2.58	1.11	1.84	2.54	0.99	1.77	2.49	0.87	1.69	2.37	0.69	1.54

	CATEGORY D - Carlton Oaks Golf Course			CATEGORY E - Highly Questionable Demand			CATEGORY F - Willowbrook Golf Course		
	Min	Max	Ave	Min	Max	Ave	Min	Max	Ave
Raw Influent	4.4	4.4	4.4	4.4	4.4	4.4	4.4	4.4	4.4
% Loss Thru Conventional Treatment	10%	10%	10%	10%	10%	10%	10%	10%	10%
Title 22 Output	3.96	3.96	3.96	3.96	3.96	3.96	3.96	3.96	3.96
PD Demands	1.17	3.15	2.51	1.86	5.05	3.69	2.48	5.77	4.19
Remaining RW	2.79	0.81	1.45	2.1	-1.09	0.27	1.48	-1.81	-0.23
% Loss Thru Advanced Treatment	15%	15%	15%	15%	15%	15%	15%	15%	15%
AWT Output	2.37	0.69	1.23	1.79	-0.93	0.23	1.26	-1.54	-0.20

5.0 Project Costs

Following is a summary of the construction cost estimates from the High Rating Study and the LISA 1 Study.

Summary of Construction Costs

Capacity	Mid Range Construction Cost (Million Dollars)	Comments
2.7 MGD Expansion		
WRF	\$8	Would require significant seasonal storage to meet yearly demand. No water sent to El Monte. Less flexibility to manage flow and demands.
4.4 MGD Expansion		
WRF	\$22	Conventional process uses current treatment process. No seasonal storage required unless Fanita Ranch is developed. Provide maximum flexibility to manage flow.
AWT	\$16	Provides El Monte 2 mgd initially, 1.0 mgd at build-out.
10 MGD Expansion		
WRF	\$82	Requires significant infrastructure to get raw wastewater to the WRF. May need to negotiate with the City of El Cajon or the County of San Diego to sell treatment capacity. Requires redundant treatment trains and solid handling processes to be independent from the METRO system.
AWT	\$14	To Serve 4.5 mgd to El Monte

A summary of project costs is shown in Table 4. The shaded area in the table shows the design cost for the expansion associated with grant. Costs total \$4.0M with ARRA grant money totaling \$1.0M.

Planning level construction costs for plant expansion options and/or additional seasonal storage is presented in Table 5.

6.0 Funding Sources

SDCWA LISA Grants. The LISA program was established by SDCWA in 2007 to provide funding to facilitate studies and investigations of local water supply opportunities. The overall goal of the LISA program is to fund local groundwater, desalination, and water recycling studies, and investigations which would lead to new local water supply or increased dry-year water supplies.

Helix Water District Participation. Helix has tentatively agreed to reimburse Padre Dam the cost of the design of the AWTP should Helix not proceed with the EMVRP.

**TABLE 4
PADRE DAM WRF EXPANSION
SUMMARY OF FUNDING CURRENTLY SECURED**

Work Description	Pre-Construction Cost	Title 16 Grant Funding	ARRA Funding Through the Bureau of Rec	Grant Funds from SDCWA	Prop 50 Grant (1)	Percent Grant
NON-CONSTRUCTION ACTIVITIES & COTTONWOOD DIVERSION						
WRF High Rating Study	\$250,000	\$62,500	\$0	\$75,000		
LISA Study, Phase 1	\$150,000	\$37,500	\$0	\$70,000		
LISA Study, Phase 2						
Dudek/RECON Consultants - Environmental CEQA Permitting						
Mitigated Negative Declaration for a 4 mgd Plant Expansion	\$154,940	\$38,735	\$0	\$47,671		
Black & Veatch - Engineering Studies/Support						
BV Project Management	\$12,710	\$0	\$3,177	\$3,911		
Study of Additional Recycled Water Demand	\$46,930	\$0	\$11,733	\$14,439		
Influent Flow Equalization (4 mgd and 10 mgd)	\$32,980	\$0	\$8,245	\$10,147		
Effluent Management Options Including Seasonal Storage	\$71,870	\$0	\$17,968	\$22,113		
Sanjee Lakes Water Quality	\$46,850	\$0	\$11,713	\$14,415		
Engineering Support for CEQA Process	\$120,000	\$0	\$30,000	\$36,921		
NPDES Permitting	\$226,780	\$0	\$56,750	\$69,775		
Coordination with Regulators	\$13,430	\$0	\$3,357	\$4,132		
Financial Feasibility Technical Memorandum	\$20,930	\$0	\$5,233	\$6,440		
Sub-total for Black & Veatch	\$592,480	\$0	\$148,174	\$182,292		
Padre Dam Management	\$70,000	\$0	\$17,500	\$21,537		
Total LISA Grant Phase 2	\$817,420	\$38,735	\$165,674	\$251,500		
ADDITIONAL WORK REQUESTED FOR DESIGN						
Direct Project Administration Cost	\$325,300	\$0	\$163,625	\$0		
Contractural						
Surveys	\$30,000	\$0	\$7,500	\$0		
Geotechnical	\$50,000	\$0	\$12,500	\$0		
Preliminary Design	\$1,080,000	\$0	\$223,550	\$0		
Detailed Design	\$2,520,000	\$0	\$941,250	\$0		
Minus Grant Adjustments			-\$347,100			
Sub-total for Additional Requested Work	\$4,005,300	\$0	\$1,001,325	\$0	\$3,000,000	
Sub-Total Non-Construction Activities	\$5,222,720	\$138,735	\$1,167,000	\$397,000	\$3,000,000	90%
Cottonwood Diversion Structure & Pipeline Replacement	\$904,000	\$200,000	\$0	\$0	\$0	
Sub-Total Non-Construction Activities & Cottonwood Creek	\$6,126,720	\$338,735	\$1,167,000	\$397,000	\$3,000,000	80%
CONSTRUCTION ACTIVITIES - PLANT EXPANSION TO 4.4 MGD - Includes a Phase 1 AWT						
Construction Management & Eng During Constr.	\$9,180,800					
Construction	\$38,000,000					
Sub-Total Constr, Activities - Plant Expansion to 4.4 mgd (2)	\$47,180,800				\$0	0%

Note. (1) Prop. 50 grant is for \$3M, you have to spent about \$4.3M before you get reimburse for the next \$3M.
(2) Total only shows grants secured to date. It is anticipated that a 25% Bureau of Reclamation Grant will be secured for the Plant Construction Phase
(3) Construction Cost Excludes \$1.3 M of new Pipelines and Conversions to RW

ADDITIONAL WORK REQUESTED FOR DESIGN	Total Costs	Conventional Cost	AWT & PS Cost	BOR Grant
Direct Project Administration Cost	\$325,300	\$182,168	\$143,132	\$163,625
Contractural				
Surveys	\$30,000	\$16,800	\$13,200	\$7,500
Geotechnical	\$50,000	\$28,000	\$22,000	\$12,500
Preliminary Design	\$1,080,000	\$604,800	\$475,200	\$223,550
Detailed Design	\$2,520,000	\$1,411,200	\$1,108,800	\$941,250
Minus Grant Adjustments	\$0		\$0	-\$347,100
Sub-total for Additional Requested Work	\$4,005,300	\$2,242,968	\$1,762,332	\$1,001,325

Total Design Cost \$3,003,975 **With BOR Grant**
Design Cost Conventional WWTP \$1,682,226 **With BOR Grant**
Current Budget for Design \$2,100,000 **W/O AWT**

**Table 5
Planning Level Construction Costs for Plant Expansion and/or Additional Seasonal Storage**

Demand Scenario Description	Plant Title 22 Inflow Capacity (MGD)	Plant Title 22 Production Capacity (MGD)	Additional Seasonal Storage Required (MG)	Plant Expansion Construction Cost (Mid Range)	Seasonal Storage Construction Cost (Mid Range)	Total Construction Cost (Mid Range)
Existing Irrigation & Lake Demand	2.0	1.8	63	\$0	\$19.5M	\$19.5M
Category A - New Demand Next to Existing RW Lines	2.7 4.4	2.4 4.0	0 0	\$8.0M \$20.2M	\$0 \$0	\$8.0M \$20.2M
Category B - Convert Potable Irrigation Demands to RW	2.7 4.4	2.4 4.0	14 0	\$8.0M \$20.2M	\$4.3M \$0	\$12.3M \$20.2M
Category C - Demand with \$1.3M Pipelines	2.7 4.4	2.4 4.0	43 0	\$8.0M \$20.2M	\$13.3M \$0	\$21.3M \$20.2M
Category D - Carlton Oaks Golf Course	4.4	4.0	0	\$20.2M	\$0	\$20.2M
Category E - Fanita Ranch and Other High Risk Demands	4.4 5.1	4.0 4.6	83 0	\$20.2M Not Estimated	\$25.7M \$0	\$45.9M Not Estimated
Category F - Willowbrook Golf Course	4.7 5.8	4.2 5.2	154 0	Not Estimated Not Estimated	\$47.7M \$0	Not Estimated Not Estimated

1. Construction costs for WRF expansion to 4.4 MGD (Inflow Capacity) were estimated based on adding 10% incremental cost to the estimated costs for WRF expansion to 4.0 MGD (Inflow Capacity).
2. Construction costs for seasonal storage include costs for 0.5 mile of 12-inch pipeline and a 4 MGD pump station.

Bureau of Reclamation. Padre Dam has received funding commitments from the Department of Interior, Bureau of Reclamation (BOR), which is authorized to allocate up to \$126M pursuant to Title XVI of the Reclamation Projects Authorization and Adjustment Act of 1992. The act authorized BOR to participate in the construction of five recycling projects, three of which were located in Southern California -- the San Diego Area Water Reclamation Program, Los Angeles Area Water Reclamation and Reuse Project, and the San Gabriel Basin Demonstration Project. Padre Dam's WRF expansion is part of the original San Diego Area Water Reclamation Program. Padre Dam's current allocation of the Title XVI funding authorizes up to 25 percent of the cost of planning, design, and construction of the first phase of the WRF expansion project. To be eligible for Title XVI funds, a water reclamation and reuse project must meet the specific BOR requirements under the National Environmental Policy Act (NEPA) and must also comply with State Revolving Fund requirements.

American Reinvestment and Recovery Act. Additionally, Padre Dam has received funding from the American Reinvestment and Recovery Act (ARRA) through the BOR, Title XVI program. The grant is for 25 percent of the design portion of the WRF expansion. The ARRA funding allowed the BOR to disburse grant funding to projects more quickly and lessened dependence on future congressional appropriations. However, all ARRA funded projects must be completed by November 2010.

State of California Proposition 50 Grant. Padre Dam has received a \$3M grant from the State of California through Proposition 50 administered by the Department of Water Resources (DWR). Additionally, Helix has received \$2.5M from the State of California through Proposition 50 for the EMVRP. The Districts are required to spend 10 percent of total project costs before grant monies are disbursed by DWR through SDCWA.

Rates. The price of conventionally treated recycled water is 90 percent of potable. It is anticipated that the largest future users, such as the Carlton Oaks Golf Course, would not buy recycled water unless it is set at a lower price. For advanced treated water, Helix would pay a negotiated cost, currently estimated in the range of \$800 to \$950 per AF.

Rebates from MWD and SDCWA. MWD is paying \$250 per AF and SDCWA is paying \$200 per AF. It is assumed Padre Dam will receive all \$450 per AF incentive.

Demand Offsets. Facilities that may qualify to be paid for by the demand offset program include the proposed \$2.5M construction of pipelines and the cost to convert existing irrigation users to recycled water.

7.0 Financial Feasibility Analysis

Black & Veatch prepared a financial feasibility analysis of various scenarios. The analysis of each scenario included the following elements:

1. Net present worth analysis for each alternative, with project costs and revenues taken over a 50-year period.
2. Sensitivity analysis to determine which factors had the most effect on the present value of an alternative.
3. Breakeven analysis to determine the minimum revenues from rates and new customers necessary to balance the cost of the WRF expansion.
4. Extent of the minimum distribution system necessary to bring in the breakeven revenues.
5. Impact on Rates.

The feasibility analysis is summarized in the following sections. The full analysis is currently being finalized by Black & Veatch in a memorandum titled Financial Feasibility Study for PDWRF Expansion.

7.1 Net Present Worth Analysis

A net present worth analysis was performed to compare the following three alternatives:

1. Baseline Case. This is a “Do Nothing” alternative where the WRF continues to produce 2 mgd.
2. Expansion to 4.4 mgd, Conventional Treatment. No advanced treated water would be produced for Helix.
3. Expansion to 4.4 mgd with AWT. The 4.4 mgd expansion adds advanced treatment of water for the Helix Groundwater Recharge Project.

A positive net present value (NPV) means that recycled revenues and savings from the project outweigh the cost. The value of all costs and revenues (future and present) are compared in present day dollars. If the NPV is positive, the project revenues are greater than the costs.

Options for the analysis were:

- Sale of METRO Capacity. Income to the District was assumed to be \$10,000 per mgd with 1.26 mgd to be sold in Phase 1, and 3.03 mgd in Phase 2.
- Point Loma Conversion to Secondary Treatment. Cost was assumed to be \$3,125,000 per mgd treated.
- Sale Price for AWT Water. The required sale price was calculated in the breakeven analysis to be in the range of \$800 to \$950 per AF.
- Reduced Water Sales. Assumed Fanita Ranch and Willowbrook Golf Course never develop and that the Carlton Oaks Country Club only uses half of their demand for the six winter months.

The rate scenario used in the NPV analysis assumed the base option of keeping the WRF at 2 mgd and that conversion to secondary treatment at Point Loma would happen. Net present values for the other expansion options were then calculated using the same rate increases. Over a 50 year period, wastewater rates would increase a total of 535 percent if Point Loma converts to secondary. Recycled water rates were held to 383 percent for both cases over the 50 year period. The rate increases on a yearly basis are shown in **Attachment C**.

Table 6 summarizes the NPV of various alternatives. All the 4.4 mgd expansion alternatives have a positive value except the option where Helix would get the incentives from SDCWA and MWD.

This analysis has been updated by modifying the financial analysis to reflect a reduced cost to treat wastewater at METRO due to sludge over-billing and reduced loading of suspended solids and chemical oxygen demand due to incorporation of In-Pipe Technology. The financial analysis was also updated to reflect the most recent estimates of the future rates for the sale of recycled water.

7.2 Sensitivity Analysis

A sensitivity analysis was performed to identify which factors had the greatest effect on NPV. The most significant variables were:

- Sale of METRO Capacity.
- Sale of AWT water.
- Point Loma WWTP conversion to secondary treatment.
- Which agency receives MWD and SDCWA rebates.

TABLE 6

Summary of Total Cash Flow NPVs for PDWRF Phase 1 Expansion
(Relative to Baseline Condition)

		Phase 1 Expansion without AWT ²		Phase 1 Expansion with AWT ²	
		Conservative Demand Assumption?		Assumes No PLWWTP Conversion AWT Water to EMVRP?	
		Yes ¹	No	Best Case ³	Worst Case ⁴
PLWWTP Conversion?	Yes	Box 1 \$37M	Box 3 \$38M	Box 5 \$33M	Box 7 \$7M
	No	Box 2 \$11M	Box 4 \$11M	Box 6 \$3M	Box 8 -\$12M
				CWA/MWD Credits	
				PD	
				Helix	

Notes:

1. Conservative Demand assumes that irrigation Categories A through D are served and Fanita Ranch and Willow Brook Golf Course never develop. Expansion to 4.0 mgd is assumed with the Conservative Demand assumption; expansion to 4.4 is assumed with the non-conservative assumption.
2. Value represents incremental increase in NPV from Baseline case.
3. Best case assumes annual average of 1.84 mgd of advanced treated water to El Monte with minimal recycled water to Padre Dam (existing irrigation users of 0.79 mgd and 1.00 mgd to the Lakes/Ponds).
4. Worst case assumes annual average of 1.23 mgd of advanced treated water to El Monte with Padre Dam to serve irrigation Categories A through D and provide 1.0 mgd to the Lakes/Ponds.

7.3 Breakeven Analysis

A breakeven analysis was performed assuming no conversion to secondary treatment at Point Loma, no participation by Helix, and no revenue from the El Monte Valley Recharge Project. A reduced rate structure was used for large water users during the winter months.

The analysis for expansion to 4.4 mgd shows that if Categories A, B and C are served, approximately 30 acre-feet per year would need to be sold to the Carlton Oakes Golf Course. For the Golf Course this is less than half of their winter demands.

HWD is taking the El Monte Project before their Board on May 19th to present the current project costs. Included in their financial assumptions are that Padre Dam would receive the CWA and MWD incentives of \$200 and \$250 respectively for water produce and that Helix would purchase the AWT water from Padre Dam at a price between \$800 to \$950/acre-foot. An additional assumption is that this price to purchase is in 2010 dollars and would increase by 5 percent per year thereafter. Padre Dam's break even analysis showed that a water sale rate within this range would be financially feasible.

8.0 Regulatory Issues

8.1 California Environmental Quality Act (CEQA)

RECON Environmental is currently preparing the environmental documentation necessary to proceed with construction of expansion to 4.4 mgd. It has recommended that a Mitigated Negative Declaration (MND) be the instrument to be used to meet CEQA and NEPA requirements. NEPA requirements also need to be met to receive Title 16 Federal Grant money from the Bureau Reclamation.

The following environmental studies are being prepared by RECON in support of the CEQA and NEPA documentations:

- Air Quality Technical Report
- Biological Resources Study/Burrowing Owl Survey
- Cultural Resources Study
- Paleontological Resources Letter Report
- Public Safety Memorandum
- Hydrology and Water Quality Technical Report
- Noise Technical Study

The MND will also evaluate the environmental impacts associated with expansion of the WRF utilizing either the membrane bioreactor technology or mirroring the existing conventional treatment process. All documentation necessary to meet environmental requirements is planned to be brought before the Board for approval in April of 2010.

8.2 Regional Water Quality Control Board Discharge Requirements

It is believed that obtaining new NPDES permit for expansion to 4.4 mgd is achievable as the approach would be similar to the recently acquired NPDES permit for the 2 mgd plant. Discharge to Sycamore Creek would be limited to 2 mgd with the same yearly mass loadings for nitrogen and phosphorous held to 1.0 and 0.1 mg/l respectively. If it is anticipated that the

WRF would treat flows in excess of the permit amount, raw sewage flow would simply not be treated at the WRF and would be sent to the Point Loma Treatment Plant for treatment.

8.3 State Department of Health Requirements

Padre Dam will need to revise the Waste Discharge Requirement for Land Application issued by the State DHS.

8.4 City of Santee Conditional Use Permit

Sale of water outside Padre Dam's service area could affect the conditions of the current Conditional Use Permit (CUP), issued by the City of Santee. The permit requires Padre Dam to serve the recycled water demands of users within the City of Santee first. This condition of the CUP could affect sale of water to Helix for the El Monte Valley Recharge Project. Use of recycled water outside Padre Dam's service area needs to be coordinated with the City of Santee.

The existing Conditional Use Permit (CUP) requires the WRF to limit odors at the property line for future development in the area. The proposed design will meet the CUP requirements.

9.0 Schedule

In order to completing the design by the end of November of 2010 and thus receiving ARRA funding, the schedule for implementing the expansion of the WRF, subject to Board approval is as follows:

Task	Schedule
Board Consideration and approval of issuing design RFP	May, 2010
Issue Design RFP	May, 2010
Award Design Contract	June, 2010
60% Design Workshop	August, 2010
Complete Design	November, 2010

10.0 Recommendations

This agenda item requests Board approval to proceed with design of the 4.4 mgd expansion, completing the design by the end of November 2010, and thus receive ARRA funding.

Padre Dam was awarded an ARRA grant of \$1,001,325, or approximately 25 percent of the design costs. An important element of the grant is that the design must be completed by November 30, 2010.

A summary of design costs is shown in Table 7. Costs total \$4,005,300 with ARRA grant money totaling \$1,001,325. Padre Dam would not proceed with design of the AWT portion of the design until we receive a commitment from Helix that if El Monte does not proceed, Helix would pay for the cost of the AWT and pump station design. Design of the AWT and pump station is estimated to be \$1,762,332. Therefore, Padre Dam's estimated cost for the design = \$4,005,300 - \$1,001,325 = \$3,003,975 (including the AWT and pump station). The current budget for design is \$2,400,000 (excluding AWT and pump station). Therefore, we have sufficient funds budgeted.

**TABLE 7
SUMMARY OF DESIGN COSTS**

ADDITIONAL WORK REQUESTED FOR DESIGN	Total Costs	Conventional Cost	AWT & PS Cost	BOR Grant
Direct Project Administration Cost	\$ 325,300	\$ 182,168	\$ 143,132	\$ 163,625
Contractural				
Surveys	\$ 30,000	\$ 16,800	\$ 13,200	\$ 7,500
Geotechnical	\$ 50,000	\$ 28,000	\$ 22,000	\$ 12,500
Preliminary Design	\$ 1,080,000	\$ 604,800	\$ 475,200	\$ 223,550
Detailed Design	<u>\$ 2,520,000</u>	<u>\$ 1,411,200</u>	<u>\$ 1,108,800</u>	<u>\$ 941,250</u>
Minus Grant Adjustments	<u>\$ -</u>		<u>\$ -</u>	<u>\$ (347,100)</u>
Sub-total for Additional Requested Work	<u>\$ 4,005,300</u>	<u>\$ 2,242,968</u>	<u>\$ 1,762,332</u>	<u>\$ 1,001,325</u>

This page intentionally left blank.

ATTACHMENT A

SYSTEM DEMAND

AND

SEASONAL STORAGE

Demands Based on Categories A through F

Month	Days per Month	Percent of Total Demand	Existing Recycled Water Demand	Potential Category "A" Customer	Potential Category "B" Customer	Potential Category "C" Customer	Carbon Oaks GC (Winter) Category "D"	Potential Category "E" Customer	Ultimate Total Irrig. Demand	Total Lake Demand (Consumptive Use + Flushing)	Exist. RW Demand Plus Total Lake Demand	Ultimate Total Irrig. Lake Demands	Lake Consumptive Use (High)	Discharge to Sycamore Creek, Lake Flushing
Jan	31	2.7%	0.23	0.03	0.03	0.12	0.50	0.37	1.57	1.06	1.34	2.66	0.74	0.35
Feb	28	2.2%	0.23	0.03	0.03	0.15	0.67	0.34	1.78	0.98	1.21	2.70	0.83	0.35
Mar	31	6.1%	0.56	0.06	0.07	0.19	0.87	0.84	3.03	0.58	1.14	3.81	0.23	0.35
Apr	30	8.1%	0.78	0.09	0.09	0.16	1.14	1.18	3.98	0.64	1.42	4.62	0.29	0.35
May	31	5.0%	0.48	0.05	0.05	0.15	0.00	0.69	2.02	0.46	0.92	2.48	0.11	0.35
June	30	11.2%	1.07	0.12	0.12	0.23	0.00	1.60	3.86	0.51	1.55	4.37	0.16	0.35
July	31	13.4%	1.25	0.14	0.15	0.21	0.00	1.86	4.35	1.12	2.37	5.47	0.77	0.35
Aug	31	13.7%	1.27	0.14	0.15	0.21	0.00	1.90	4.39	1.36	2.65	5.77	1.03	0.35
Sept	30	12.2%	1.19	0.13	0.14	0.24	0.00	1.75	4.02	1.42	2.60	5.44	1.07	0.35
Oct	31	12.6%	1.20	0.13	0.14	0.20	0.00	1.78	4.02	1.41	2.61	5.31	1.06	0.35
Nov	30	8.2%	0.88	0.10	0.10	0.18	0.64	1.31	3.51	1.26	2.13	4.78	0.90	0.35
Dec	31	3.8%	0.36	0.04	0.04	0.12	0.34	0.50	1.90	1.15	1.51	3.05	0.80	0.35
Yearly Average		100%	0.79	0.09	0.09	0.18	0.37	1.18	3.19	1.00	1.78	4.19	0.65	0.35

Min
Max

0.92
2.65

Min
Max

0.92
2.65

Potential Category "A" Customer	Potential Category "B" Customer	Potential Category "C" Customer	Carbon Oaks GC (Winter) Category "D" Customer	Potential Category "E" Customer	Potential Category "F" Customer
1.35	1.39	1.51	2.03	2.40	2.66
1.23	1.28	1.40	2.09	2.42	2.76
1.21	1.27	1.48	2.33	3.17	3.61
1.50	1.59	1.75	2.89	4.05	4.62
0.97	1.03	1.17	1.17	1.86	2.49
1.70	1.83	2.06	2.06	3.60	4.37
2.51	2.65	2.88	2.88	4.72	5.47
2.79	2.84	3.15	3.15	5.05	5.77
2.73	2.85	3.10	3.10	4.86	5.44
2.75	2.89	3.09	3.09	4.89	5.31
2.23	2.33	2.48	3.13	4.44	4.78
1.55	1.59	1.71	2.25	2.78	3.05
1.88	1.97	2.15	2.51	3.88	4.19

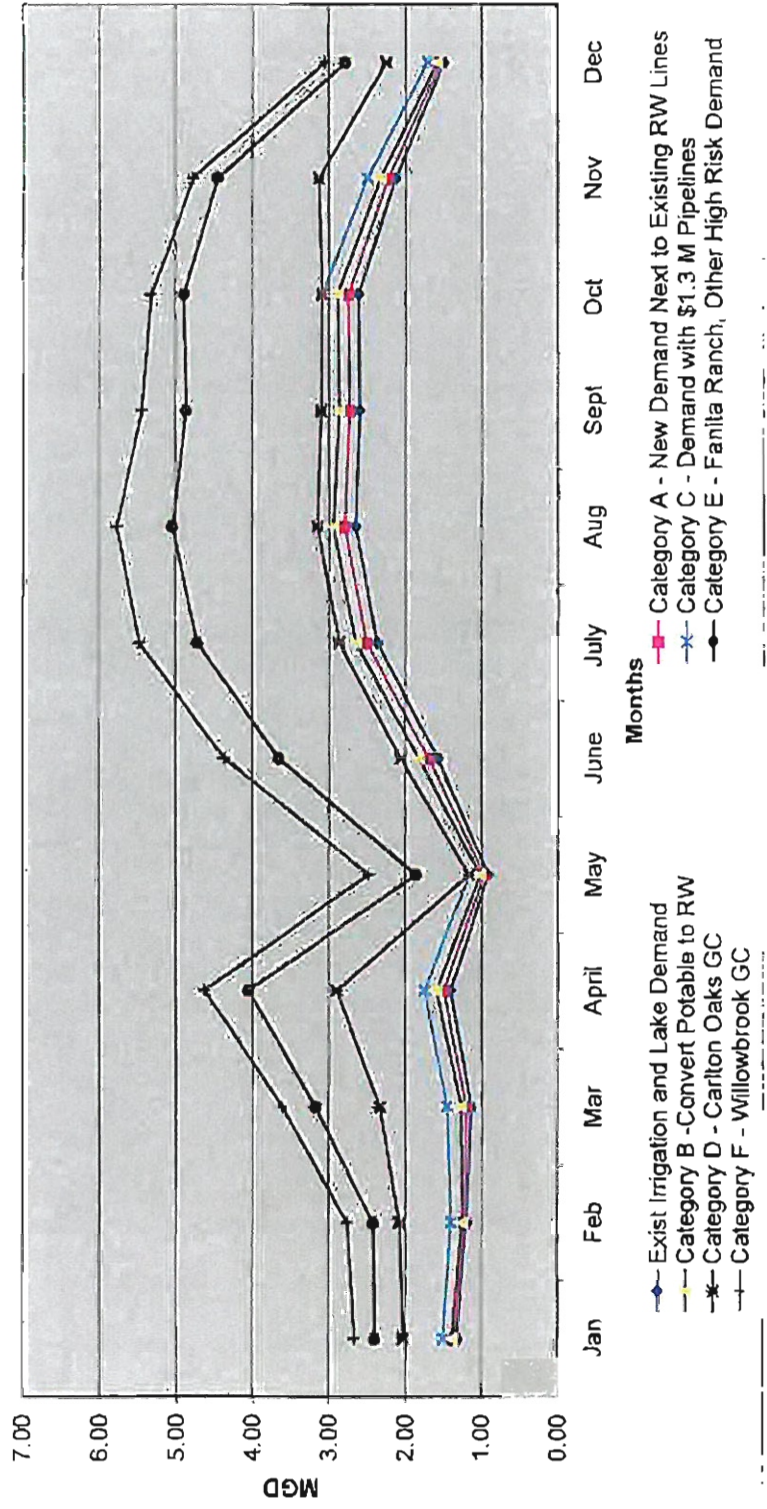

Demand Scenarios and Treatment Plant and Seasonal Storage Needs

Demand Scenario Description	Total Average Annual Demand ¹ (MGD)	Peak Summer Month Demand (MGD)	Plant Title 22 Influent Capacity (MGD)	Plant Title 22 Production Capacity ² (MGD)	Total Seasonal Storage Required ³ (MG)	Existing Seasonal Storage (MG)	Additional Seasonal Storage Required (MG)
Existing Irrigation & Lake Demand	1.79	2.65	2.0	1.8	103	40	63
Category A - New Demand Next to Existing RW Lines	1.88	2.79	2.7 4.4	2.4 4.0	36 0	40 40	0 0
Category B – Convert Potable Irrigation Demands to RW	1.97	2.94	2.7 4.4	2.4 4.0	54 0	40 40	14 0
Category C – Demand with \$1.3M Pipelines	2.15	3.15	2.7 4.4	2.4 4.0	83 0	40 40	43 0
Category D – Carlton Oaks Golf Course	2.51	3.15	4.4	4.0	0	40	0
Category E – Fanita Ranch and Other High Risk Demands	3.69	5.05	4.4 5.1 ⁴	4.0 4.6	123 34	40 40	83 0
Category F – Willowbrook Golf Course	4.19	5.77	4.7 ⁵ 5.8 ⁴	4.2 5.2	194 37	40 40	154 0

1. Includes existing demand for recycled water customers and lakes. Includes total lake demand of 1.0 mgd, which is evapotranspiration plus flushing.
2. Assumes approximately 10% water loss through the plant due to sludge, evaporation, and other losses.
3. Assumes no potable or raw water supplementation.
4. Minimum influent plant capacity required to meet the peak summer month demand without requiring additional seasonal storage.
5. Minimum influent plant capacity required to meet the annual average demand.

ATTACHMENT B

EL MONTE VALLEY RECHARGE

PHASED PROJECT

El Monte Valley Recharge Phased Project

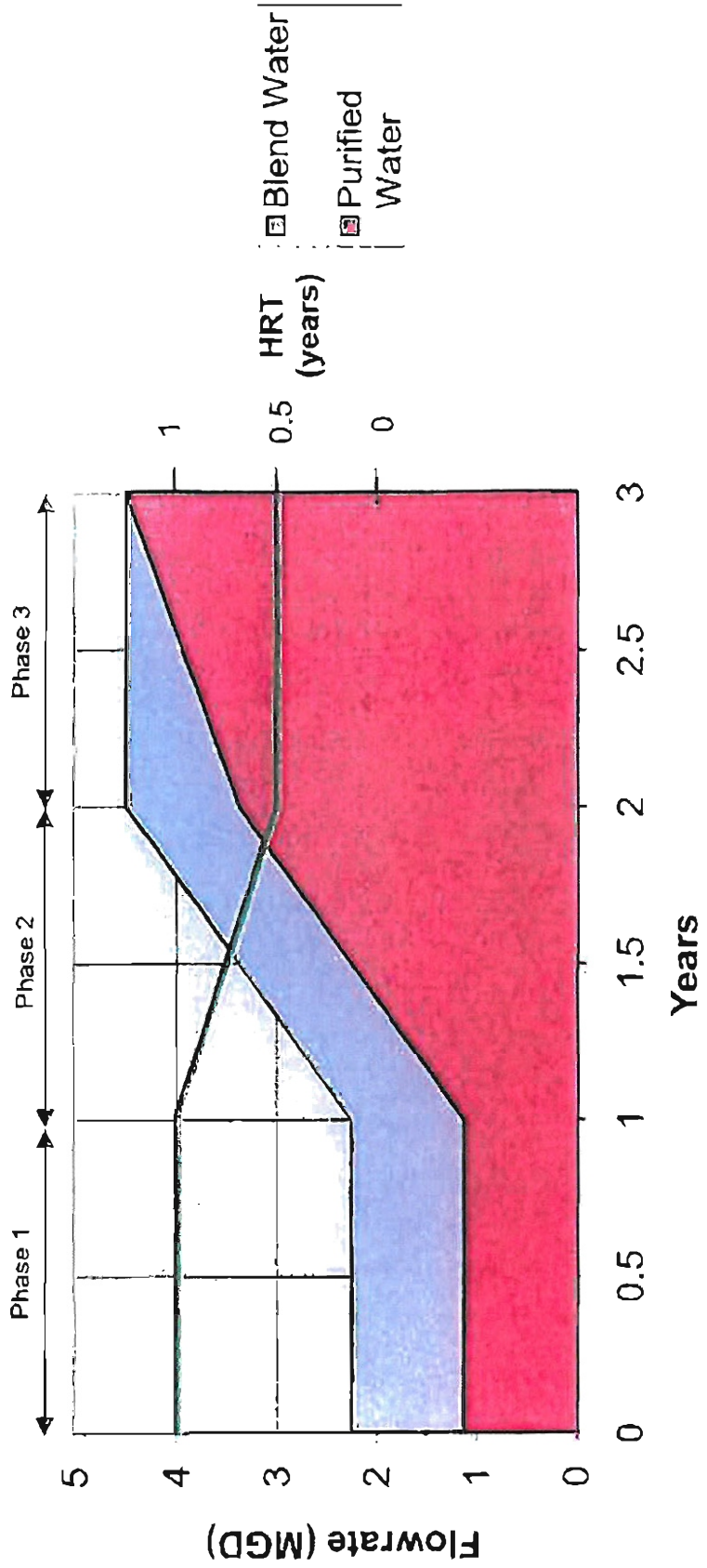

ATTACHMENT C

RATE INCREASES

WITH NO EXPANSION AND

WITH POINT LOMA CONVERSION TO

SECONDARY

ATTACHMENT C

BASE OPTION (No Expansion)
 RATES NEEDED WITH POINT LOMA CONVERSION TO SECONDARY

Fiscal Year Ending June 30,	Baseline Case			
	Wastewater		Recycled Water	
	Annual	Cumulative	Annual	Cumulative
	%	%	%	%
2010	5.0%	5.0%	16.2%	0.0%
2011	5.0%	10.3%	10.3%	10.3%
2012	5.0%	15.8%	9.2%	20.4%
2013	5.0%	21.6%	3.0%	24.1%
2014	5.0%	27.6%	3.0%	27.8%
2015	5.0%	34.0%	3.0%	31.6%
2016	5.0%	40.7%	3.0%	35.6%
2017	5.0%	47.7%	3.0%	39.6%
2018	5.0%	55.1%	3.0%	43.8%
2019	5.0%	62.9%	3.0%	48.1%
2020	5.0%	71.0%	3.0%	52.6%
2021	5.0%	79.6%	3.0%	57.2%
2022	5.0%	88.6%	3.0%	61.9%
2023	5.0%	98.0%	3.0%	66.7%
2024	3.0%	103.9%	3.0%	71.7%
2025	3.0%	110.1%	3.0%	76.9%
2026	3.0%	116.4%	3.0%	82.2%
2027	3.0%	122.8%	3.0%	87.7%
2028	3.0%	129.5%	3.0%	93.3%
2029	3.0%	136.4%	3.0%	99.1%
2030	2.0%	141.1%	3.0%	105.1%
2031	2.0%	146.0%	3.0%	111.2%
2032	3.0%	153.3%	3.0%	117.5%
2033	3.0%	160.9%	3.0%	124.1%
2034	3.5%	170.1%	3.0%	130.8%
2035	3.5%	179.5%	3.0%	137.7%
2036	3.5%	189.3%	3.0%	144.8%
2037	3.5%	199.4%	3.0%	152.2%
2038	3.5%	209.9%	3.0%	159.8%
2039	3.0%	219.2%	3.0%	167.5%
2040	3.0%	228.8%	3.0%	175.6%
2041	3.0%	238.7%	3.0%	183.8%
2042	3.5%	250.5%	3.0%	192.4%
2043	3.5%	262.8%	3.0%	201.1%
2044	3.5%	275.5%	3.0%	210.2%
2045	3.5%	288.6%	3.0%	219.5%
2046	3.0%	300.3%	3.0%	229.1%
2047	3.0%	312.3%	3.0%	238.9%
2048	4.0%	328.8%	3.0%	249.1%
2049	4.0%	345.9%	3.0%	259.6%
2050	5.0%	368.2%	3.0%	270.4%
2051	5.0%	391.6%	3.0%	281.5%
2052	5.0%	416.2%	3.0%	292.9%
2053	3.0%	431.7%	3.0%	304.7%
2054	3.0%	447.7%	3.0%	316.8%
2055	3.0%	464.1%	3.0%	329.3%
2056	3.0%	481.0%	3.0%	342.2%
2057	3.0%	498.4%	3.0%	355.5%
2058	3.0%	516.4%	3.0%	369.1%
2059	3.0%	534.9%	3.0%	383.2%

APPENDIX J: COMMENT/RESPONSE FORM



This page intentionally left blank.

Appendix J
City of San Diego / Public Utilities
Recycled Water Study
Draft Report

NO.	REFERENCE	COMMENT	CITY RESPONSE
BB-1	ES 17 Alternate A1/A2 Capital and O&M Costs per Phase. ES 19 Alternate B1/B2 Capital and O&M Costs per Phase. ES 21 Alternate B3 Capital and O&M Costs per Phase.	The cost numbers being shown to the nearest dollar misrepresents the precision of the cost estimates and may leave readers with an impression that costs are known with great precision. Suggest rounding costs to the nearest value consistent with the precision of the estimates.	The cost numbers have been rounded.
BB-2	ES 14 and ES 26	On page ES 14, the split plant location is referred to as Camino del Rio. On page ES 26 in the Recycled Water Study Project Implementation Summary the split plant location is referred to as Stadium. They should be made consistent.	Revised Figure on ES 26 to refer to the Camino del Rio site.
BB-3	Table 5-3, last Note	Note refers to Chapter 9 for Integrated Reuse Alternatives. Should be Chapter 8.	Revised
BB-4	Page 6-2, 1 st ¶, 3 rd Sentence	Suggest replacing "...this Study..." with "...the current Study..." The use of "...this Study..." here is somewhat confusing.	Revised
BB-5	Page 6-2, 2 nd bullet	The bullet appears to imply that secondary treatment will not be needed at Point Loma. The significant cost savings of reducing flows at Point Loma assuming secondary at Point Loma is required isn't mentioned. At the Fine Screening session and SUM 10, the Study was described as assuming secondary would be needed at Point Loma WWTP, offset savings would be based requiring secondary at lower flows at Point Loma, and the possibility that secondary would not be needed would be discussed.	This sentence has been deleted.
BB-6	Page 7-2, last	Add a disadvantage of pumping wastewater is the	Revised.

Appendix J
City of San Diego / Public Utilities
Recycled Water Study
Draft Report

NO.	REFERENCE	COMMENT	CITY RESPONSE
	bullet	increased adverse environmental impact should a spill occur.	
BB-7	Page 8-7, Table 8-4	The cost numbers being shown to the nearest dollar misrepresents the precision of the cost estimates and may leave readers with an impression that costs are known with great precision. Suggest rounding costs to the nearest value consistent with the precision of the estimates.	Revised
BB-8	Page 8-16, Table 8-14, 1 st row.	How does averaging \$1.4 and \$1.0 billion equal \$1.1 billion in savings? I think it's probably round off error but it might be clearer to round to two decimal points.	Section revised to alternative approach.
BB-9	Page 8-16, Table 8-14, 2 nd row, last sentence	It might be clearer to start the sentence "The <i>additional</i> savings..."	Revised.
Otay-1	General	The City provided this comment sheet and solicited comments from the PAs for several TMs. Room was provided on the comment sheet to note the action taken in response to the comment made by the PAs. To date, no response has been received. Before this draft can be finalized and accepted, the PAs deserve a response to their comments.	The comment/response forms for the Technical Memoranda (TM) developed for this Study have been included in the appendices of each TM, which have been provided to the PA's. The comment/response form for this Report will be included in the appendices.
Otay-2	General	At the same time the City initiated the IPR demonstration project, City budgeting for non-potable water has disappeared. With the timeline for implementation for the IPR 10 years or more away, why isn't the City and this report recommending investing in expanding the non-potable purple pipe to offset the use of potable water supplies?	There is a 66% increase in NPR planned for Otay, Poway, Olivenhain, and the City. See Fig 5-3, Table 5-3 and TM 1.
Otay-3	General	Please address within the Study the existing and	Timing of projects is included in Chapter 8. South

Appendix J
City of San Diego / Public Utilities
Recycled Water Study
Draft Report

NO.	REFERENCE	COMMENT	CITY RESPONSE
		projected recycled water demands that the City customers, Otay WD, and IPR supply requirements are relative to the timing and quantities of proposed diversions of wastewater to the South Bay Plant. A table could be added to the report that lines up demand level projections over time against wastewater supply needs (i.e. diversions to the South Bay Plant). Please add this to the Study.	Bay diversions are included in the 1 st phase. Interim conditions will be discussed directly between the City and OWD outside of this study per previous responses.
<i>Otay-4</i>	General	It looks as though the collected unit cost data used to develop infrastructure and operational costing include the revenue side of the equation. Who gets or owns the IPR water after all is said and done and how much will they pay for the water? How do the PA's get reimbursed for their costs? Where is the nexus per AB1600 between cost and benefit for sewer service versus the water customers and how will this be addressed? Both analyses need to be separately for the South Bay and North City Systems/Plants.	The financial model had a line for revenue which was interest from bonds. This has been re-labeled to more accurately what this is. There was a cost sharing workshop which is outlined in Section 8.5. This is the framework for future discussions on cost sharing.
<i>Otay-5</i>	General	The Study did not discuss near term recycled water needs of the Otay WD from the South Bay Plant. Otay's highest peak day is 7.83 mgd already (not including the City's own customers at South Bay Plant). If you add the current City customers of 1.35 mgd to the Otay value, South Bay Plant is already at 9.18 mgd on a peak day. Since Marsi S. states that the IBWC South Bay Plant demand will be going away please adjust the numbers accordingly and state the timing. This needs to be fully addressed within the Study and within the financial model.	Interim flow diversions will not be discussed in this study. Otay and the City have discussed the funding of the Salt Creek diversion and those discussions will be held outside of this study per previous responses.
<i>Otay-6</i>	General	Need to include and discuss wastewater flow diversions into the South Bay Plant to increase recycled water production levels to meet known existing and future recycled water demands of the Otay WD and any other City customers both existing and future. The Salt Creek Diversion is being addressed currently and needs to be	See Otay-5. The Study addresses the long term solution.

Appendix J
City of San Diego / Public Utilities
Recycled Water Study
Draft Report

NO.	REFERENCE	COMMENT	CITY RESPONSE
		clearly discussed within the Study as a short or near term item with specific timelines. Please be very clear and state in the text the specific diversion(s) the Study addresses for increased flow to the South Bay Plant including the quantities of each and timing.	
<i>Otay-7</i>	General	Within a previous TM, the text stated “maximize the City’s and PA’s investment in existing infrastructure” how do you plan to share the costs and benefits from this with the PA’s? How does the split of costs and benefits between the South Bay System/Plant and the North City System/Plant be determined? Will all revenues from sales of water go back to PA’s per the contract? It appears that both the expenditure and revenue side of the financial model have been built so please calculate the payback period for both the South Bay and North City Systems/Plants separately. Do these solutions look at the concept of designer water where you maximize the least expensive options first and then go to the more expensive options if feasible, as we believe the City should?	See Otay-4
<i>Otay-8</i>	General	Please provide very concise statements within the Study report that IPR owners and operators are to pay the NPR water rate for the supply of NPR water to be run through the IPR process and that the PA’s expect to share in the revenues generated beyond the O&M expenses from any sales of NPR and IPR water, per the existing contracts.	See Otay-4
<i>Otay-9</i>	General	The PA’s would like some discussion within the Study about the process, timing, and estimated dollar amounts that the City of San Diego owes the PA’s for their recycled water sales revenues received from the wholesale recycled water purchasers per terms of the South Bay and the North City agreements.	This is outside the scope of this study
<i>Otay-10</i>	General	Do the baseline non-potable reuse opportunities align with all other items such as the pricing study, the	See response to previous comments.

Appendix J
City of San Diego / Public Utilities
Recycled Water Study
Draft Report

NO.	REFERENCE	COMMENT	CITY RESPONSE
		recycled credits reported to CWA, and the recycled uses projected and reported to CWA? If not they should. The PA's have asked the City to provide a reconciliation of all of these numbers.	
<i>Otay-11</i>	General	It is the Otay WD vision to have two separate rates one for supply from the South Bay Plant and one for supply from the North City Plant. Also, these two separate rates need to be further subdivided to a wholesale rate and retail rate for supply from each separate T/Plant.	The City has one recycled water system. See response to previous comments.
<i>Otay-12</i>	General	The TM's imply a single price for recycled water. There needs to be a separate price for wholesale and retail recycled water. Also, there needs to be separate and different price structures, one for recycled water produced at the South Bay Plant and one for the North City Plant. The systems are not connected and operate separately and Otay WD constructed the capital improvement infrastructure system to the South Bay Plant. There is no nexus between the two City T/Plants or their associated recycled water systems. Please address in the Study.	See response to previous comments.
<i>Otay-13</i>	General	Comments received from the PA's and others on the draft Study report need to be fully addressed in a timely manner and incorporated into a final draft Study report. The Final Draft Study Report should then be prepared and distributed to all stakeholders and the PA's for final review and comment. The Final Study Report should then be prepared and distributed to all stakeholders incorporating the comments.	The City is taking every effort to incorporate all comments generated by the PAs. However, the City believes that comments that are outside the scope of this study should be dealt with separately and not included.
<i>Otay-14</i>	General	As the Otay WD is a South Bay Plant wholesale customer, the existing South Bay Plant recycled water supply agreement with the City does not limit the maximum recycled water flow rate at 6.0 mgd. The agreement states: "10 million gallons per day is available for sale"; "Reclaimed Water produced at SBWRP shall be	OWD supplies via South Bay are accounted for in the Study. Nowhere in the Study does it show these demands going away.

Appendix J
City of San Diego / Public Utilities
Recycled Water Study
Draft Report

NO.	REFERENCE	COMMENT	CITY RESPONSE
		<p>pumped to Otay's 450 zone in an amount equal to or greater than 6 MGD"; and "SBWRP production of Reclaimed Water will meet Otay's peak summer and winter seasonal orders". Otay's peak demand in previous summer months has already been as high as 7.8 mgd. Please address this within the Study. The 6 mgd is not a maximum amount that the City is to supply - the 6 mgd is a minimum amount. The Otay WD can and has the right to take more from the City's South Bay Plant if it is available. The City is not operating the South Bay Plant under the premise and as per terms of the agreement that sufficient wastewater flows are being sent to the South Bay Plant to produce and "of which 10 mgd of tertiary water which is available for sale" at the South Bay Plant. Again just because the existing agreement has a term ending 2026 does not imply or mean that the Otay WD supply needs from the South Bay Plant go away after 2026.</p>	
<i>Otay-15</i>	General	<p>The Otay WD currently receives LRP credit money for retail sales of recycled water that is supplied from the South Bay Plant. Going forward that expectation remains unchanged, thus including revenue to the City of LRP money at the South Bay Plant for non-potable wholesale sales to Otay WD should not occur within the revenue side of the financial model for the City would not receive LRP credit money for the same water.</p>	<p>The model looks conceptually at the financial accounting as a whole and does not appropriate revenue or credits. This would occur in the cost sharing discussions laid out in Section 8.5</p>
<i>Otay-16</i>	General	<p>Many of the figures and photos throughout the draft report are too small to be easily be read and viewed. Please increase the size of the figures to fill a full page and photos as is appropriate.</p>	<p>The photos have been resized and sharpness has been increased in an attempt to make the images as legible as possible.</p>
<i>Otay-17</i>	General	<p>The proposed pricing structure for non-potable recycled water must recognize a need for a wholesale and retail rate. Additionally, recognize the difference in cost and who paid and who benefits between North City and South Bay plants. Finally, to the extent that City recovers full</p>	<p>As stated in our previous responses, the City believes that pricing of recycled water should be dealt with outside this study.</p>

Appendix J
City of San Diego / Public Utilities
Recycled Water Study
Draft Report

NO.	REFERENCE	COMMENT	CITY RESPONSE
		cost, per the agreement with the PA's the amounts over the City's O&M cost should be repaid to the Metro side from the Water side of the City operations. When will the revised pricing study, being prepared by Raftelis Financial Consultants, be released? It is the PA's understanding that the report is complete and the City is using it for this Study. The PA's have asked but have not received an official copy of the revised Raftelis study for review, comment, and discussion.	
<i>Otay-18</i>	General	The revised and latest Raftelis Financial Consultants report needs to be distributed to the PA's for review, comment, and discussion. The report should than be revised to incorporate the PA's previous and any new comments. Please revise the Raftelis Report accordingly after receipt of the PA's latest comments.	See response to Otay-17.
<i>Otay-19</i>	General	The demand and supply numbers used in the Raftelis Financial Consultants Report need to be consistent with that used in the Recycled Water Study. Please be sure and so state within the text that this in fact the case or revise the Raftelis Report accordingly.	See previous response to this comment.
<i>Otay-20</i>	General	At South Bay Plant the Otay WD needs to have the first right to recycled water to serve existing and planned future demands. The existing SBWRP Agreement needs to be revised to accommodate changed conditions and must be renewed in the future. The remaining unused tertiary product water or supply from the South Bay Plant then could be treated to the advanced treatment level and used for IPR purposes. Please so state in the text of the report that this will be the approach. Mr. James Strayer does mention the South Bay Plant supply during summer/winter flows for NPR and IPR on page 3 of the Fine Screening Session Meeting Minutes notes. The Study also needs to address peaking, to minimize or eliminate any potable supplements into the recycled distribution system. This is why the priority of flows	This is outside the scope of this study.

Appendix J
City of San Diego / Public Utilities
Recycled Water Study
Draft Report

NO.	REFERENCE	COMMENT	CITY RESPONSE
		<p>needs to be addressed. Additionally, the study does not address the City's own recycled customers at South Bay Plant that in FY 2010 reached 1.35mgd (1515 af) of sales. The other recycled customers of the City at South Bay Plant need to be included in the current and future demands. Please address within the Study text. The Otay WD ultimate recycled water annual average irrigation demand is estimated to be at least 10,000 acre feet. Marsi Steirer on page 10 of the Fine Screening Session Meeting Minutes notes, states that the IBWC will not purchase recycled water supply from the SBWRP in the future. When will this occur and what is the quantity, 0.65 mgd? Please so state this information in the text of the Study. Please list all existing and future NPR recycled water customers of the City that are and will be supplied with NPR water from the SBWRP and the quantities and schedule for such uses.</p>	
Otay-21	General	<p>The financial rate models should not assume only newly created water credited by new facilities. The rate model should start from existing conditions. The City cannot now divert enough good quality wastewater to the South Bay Plant to meet Otay WD needs and at the same time limit flows to Otay WD to 6 mgd. The Otay WD cannot take 6 mgd from the SBWRP for recycled water irrigation uses every day of the year and in the summer months Otay WD needs much more than 6 mgd of recycled water supply, so making an assumption that Otay WD will take 6 mgd on an annual average basis is simply an error that should not be within the rate model. That is another reason why the rate model must use monthly analyses not use annual average values. Again the Otay WD needs at least 18 mgd of supply in the summer months within the Study analysis period to meet planned and well documented irrigation demands only. This 18 mgd value does not include non irrigation industrial demands for</p>	See previous response to this comment.

Appendix J
City of San Diego / Public Utilities
Recycled Water Study
Draft Report

NO.	REFERENCE	COMMENT	CITY RESPONSE
		recycled water that are likely to materialize within the Otay WD jurisdiction. As a result the Study should reflect the known and predictable monthly supply production levels on a monthly basis for both non-potable production and IPR production levels. To simply assume 3 mgd additional non-potable production for Otay WD is not valid and will result in financial model outcomes that are neither valid nor useful.	
<i>Otay-22</i>	General	The rate models should not assume full or 100% recycled water production at the end of construction activities for non-potable reuse for irrigation demands will grow as development activities occur for at least within the South Bay region in the Otay WD jurisdiction. Also, full production of IPR uses will not occur as well within the South Bay. The non-potable reuse values will vary from summer to winter and conversely affect the magnitude of IPR flows to the Otay Lakes. These facts must be incorporated within the financial model. Please discuss this in text of the Study.	See previous response to this comment.
<i>Otay-23</i>	General	The financial rate models need to be developed with recycled water production levels and demand uses on a monthly basis and not on an annual average basis to reflect production and demand variations that will exist from winter through summer month conditions for both NPR and IPR water types. Using annual average values for production and demand will not correctly reflect the reality of operations from winter through summer periods. Also, will sufficient wastewater be diverted to the South Bay Plant of sufficient quality in a timely manner to meet peak summer month non-potable recycled water demands of that of Otay WD and any other City customers, please state the facts? These two items are important factors on how this will be addressed within the model and will have a significant effect on the financial model outcomes.	See previous response to this comment.

Appendix J
City of San Diego / Public Utilities
Recycled Water Study
Draft Report

NO.	REFERENCE	COMMENT	CITY RESPONSE
<i>Otay-24</i>	General	<p>The Otay WD, as a wholesale recycled water customer, has a contractual commitment per terms of an existing supply agreement with the City of San Diego that specify annual volumes of recycled water to be purchased. The Otay WD has invested over \$43 million of dollars in infrastructure based on the contract. Additionally the Study team appears to address the Otay WD's demands as though they will end in 2026 when the contract term ends, but in fact the demands will continue indefinitely, and with increasing demands up to at least 18 million gallons a day for a peak summer month. The City must be responsible to meet the existing and future NPR demands of the Otay WD supplied from the South Bay Plant. Please make a definitive statement that provides surety to the Otay WD about supplies will in fact be available to the Otay WD to meet their existing and future needs and peak month supplies as well as the supply needs are requested by Otay WD. Please be responsible to rate payers region wide to ensure the maximum demands of the much lower cost water (wastewater treated to the tertiary level) is served prior to the more expensive demands of IPR which requires maybe billions of dollars in infrastructure, plus a second treatment process after the AWT water is placed into local reservoirs. Does the City plan to request or require that the PA's pay for any of the costs for IPR? Does the City intend to claim that the IPR water is 100% owned by the City or what?</p>	See response to previous comments
<i>Otay-25</i>	General	<p>As discussed at previous Metro TAC meetings the vision of the study should be to incorporate the concept and strategy that the total solids loading into the Pacific Ocean from the Point Loma WWTP at the advanced primary level will be substantially reduced by increasing the reuse of recycled water at other local treatment facilities. The strategy is that by agreement with EPA to</p>	Both options are addressed in this study.

Appendix J
City of San Diego / Public Utilities
Recycled Water Study
Draft Report

NO.	REFERENCE	COMMENT	CITY RESPONSE
		<p>permit the Point Loma WWTP at the advanced primary level at a reduced total flow than it is now such that the total annual loading into the ocean would be less than running Point Loma at say 240 mgd at the secondary level. This could be a long term solution which would avoid the waiver process (i.e. obtain a permanent advanced primary permit). This would allow for assurance and rate stability to sewer rate payers, PA's, using the Metro System. A Win-Win situation for all. Potential substantial sewer rate increases would otherwise result if the Point Loma WWTP were required to go to secondary treatment even at 100 mgd diversion away from the Point Loma WWTP. Please add to text to the Study that this strategy is contemplated to be accomplished by the City.</p>	
<i>Otay-26</i>	General	<p>The City needs to address and recognize that the Ocean Protection Reduction Act requirement not only required the construction of 45 mgd of recycled water production capacity but also intended the marketing and reuse of the 45 mgd. This has to be addressed in an appropriate manner in the recycled water study.</p>	<p>The City is aware of all requirements under the Ocean Protection Reduction Act and is in line with all requirements.</p>
<i>Otay-27</i>	General	<p>In the modified NPDES and 301 (h) Tentative Decision Document (TDD), the City proposed to bring additional recycled water users online to reduce dry-weather flows from both reclamation plants. The TDD is dated 12/2/2008 so progress is needed soon for the next 5-year cycle. Why isn't this discussed in this report?</p>	<p>The recycled water study addresses NPR during the next five years.</p>
<i>Otay-28</i>	General	<p>Is the City going to maximize the South Bay WRP by diverting more wastewater for secondary and tertiary treatment or is this report going to sit on a shelf and then state that the City met the requirements of the Cooperative Agreement</p>	<p>The City intends to pursue recycling effort whenever possible. This report is being prepared in order to explore all options and determine costs. Once that is determined it will be taken to Council for approval.</p>
<i>Otay-29</i>	Section 1.1	<p>It appears that the documents included in Appendix A are not the Cooperative Agreement. Please include the</p>	<p>The Cooperative Agreement is now included in Appendix A.</p>

Appendix J
City of San Diego / Public Utilities
Recycled Water Study
Draft Report

NO.	REFERENCE	COMMENT	CITY RESPONSE
	Pg. 1-1	approved and signed Cooperative Agreement as well.	
<i>Otay-30</i>	Section 1.1 Pg. 1-1	The City of San Diego and the Recycled Water Study (Study) team continues to state that “the City’s responsibility per the Cooperative Agreement is to execute the Study”, clearly implying that the City’s only intent is to complete the Study and not create additional recycled water local supplies for both non potable and indirect potable reuses. The “Goal” of the study as stated is “Maximization of reuse.” Completing the Study does nothing toward developing actual reuse projects nor addresses the Point Loma WWTP potential requirement to change to secondary treatment.	There is no clear intent here. This is only stating the requirements of the agreement.
<i>Otay-31</i>	Section 1.1 Pg. 1-1	This section needs to be modified to note the Cooperative Agreement is not only to prepare the study but also to “pursue opportunities to implement recommendations developed as appropriate”.	This section is written per the agreement.
<i>Otay-32</i>	Section 1.2 Pg. 1-1	The Study is deemed incomplete for it did not address and evaluate all viable recycled water supplies and reuse opportunities or options that the wholesale recycled water users and the Participating Agencies (PA’s) are interested in accomplishing that were identified by the PA’s in the White Paper. These opportunities are clearly within the intended Study purpose and approach. Given the fact that the Study team has not addressed these opportunities the Study appears to be incomplete. The Study team appears to have purposely not included those opportunities that were identified early enough during the Study by the PA’s to be dealt with by the Study team. It is clear that the City of San Diego has an agenda to direct essentially only its attention within the Study to indirect potable reuse primarily targeted at San Vicente Reservoir to the exclusion of existing viable non-potable reuses of the wholesale recycled water agencies and other PA’s.	This is not an accurate comment as PA representatives were involved throughout the Study and options were not ignored. Not all PA suggestions were included, but they were vetted in workshops and this is a multi-stakeholder process. The plan conclusions show regional benefits. Implementation steps outline important cost sharing discussions needed. Specific to OWD, expansion of South Bay provides desired NPR demands which is contrary to the comment.

Appendix J
City of San Diego / Public Utilities
Recycled Water Study
Draft Report

NO.	REFERENCE	COMMENT	CITY RESPONSE
<i>Otay-33</i>	Figure 1-1 Pg. 1-2	The figure does not correctly depict the boundaries of the Otay WD on Otay Mesa and else where nor that of the Spring Valley Sanitation District, now known as the San Diego County Sanitation District.	This figure has been revised. Regarding Otay Mesa, it shows sewerage service areas which still need to be confirmed between the City and County. Edits were made in this section to address the recent County Consolidation.
<i>Otay-34</i>	Section 1.3 Pg. 1-3	Is the City of San Diego considered a PA? Should the table list the City of San Diego as a separate stake holder?	Revised
<i>Otay-35</i>	Section 1.3 Pg. 1-3	This is a repeat comment from TM 6, 7 & 8. The City has once again failed to include existing wholesale customers as stakeholders of this study. The Otay WD (OWD) has invested over \$43 million of dollars in infrastructure based on the contract, and therefore OWD and others are very much stakeholders in the process to develop the Study. Additionally the Study team addresses the OWD's demands as though they will end in 2026 when the contract term ends, but in fact the demands will continue indefinitely, and with increasing demands up to at least 18 million gallons a day for a peak summer month. The City must be responsible to meet the existing and future Non-potable recycled (NPR) demands of the OWD supplied from the SBWRP. Please make a definitive statement that provides surety to the OWD that supplies will be available to the OWD to meet their existing and future needs and peak month supplies as well as the supply needs requested by OWD. Please be responsible to rate payers region wide to ensure the maximum demands of the much lower cost water NPR is served prior to the more expensive demands of IPR which requires maybe billions of dollars in infrastructure, plus a second treatment process after the IPR water is placed into local reservoirs. Does the City plan to request or require that the PA's pay for any of the costs for IPR? Does the City intend to claim the IPR water is 100%	This is an unfair comment. See response in this form and on previous comments

Appendix J
City of San Diego / Public Utilities
Recycled Water Study
Draft Report

NO.	REFERENCE	COMMENT	CITY RESPONSE
		owned by the City?	
<i>Otay-36</i>	Section 1.4 Pg. 1-3	The Study process overview description is incomplete. Please address that the TM's were distributed to the PA's for review and comment. Did the City address all of the PA's comments on the TM's?	The comment/response forms for the Technical Memoranda (TM) developed for this Study have been included in the appendices of each TM, which have been provided to the PA's. The comment/response form for this Report will be included in the appendices.
<i>Otay-37</i>	Section 1.5 Pg. 1-4	Identify how the TMs are integrated into this draft version. For example, where is TM 1 reuse market assessment included in the final version?	This could be a broad and complicated mapping producing little benefit. The report was designed to stand alone with additional details provided via the TMs.
<i>Otay-38</i>	Section 1.6 Pg. 1-4	Add "Wholesale Connection" as key term. It is used throughout this report but documents referenced in this report make no distinctions between a typical customer meter and a wholesale customer like Otay WD that has their own customer base.	Wholesale Customer was added to the glossary.
<i>Otay-39</i>	Section 2.1 Pg. 2-1	<p>Please reword the second sentence for water supply is obtained for the Bay-Delta and the Colorado River and conveyed via the California Aqueduct and the Colorado River Aqueduct.</p> <p>Revise text in second paragraph in that water is not supplied from the State Water Project it is conveyed via the State Water Project and supplied from the Bay-Delta.</p> <p>In last paragraph, it is clear that the Study focuses on an area greater than the Metro Service Area for any new local water supply will benefit the entire San Diego County region. Please reword and also please define the Metro Service Area.</p>	<p>Revised.</p> <p>Revised.</p> <p>The study generally stays focused on the Metro Service Area. Chapter 1 includes a revised figure on the Metro Service Area.</p>
<i>Otay-40</i>	Section 2.1	It should be clearly stated within the text of the Study and thoroughly evaluated that the environmental community's	The environmental community has reviewed this text and not suggested this change.

Appendix J
City of San Diego / Public Utilities
Recycled Water Study
Draft Report

NO.	REFERENCE	COMMENT	CITY RESPONSE
	Pg. 2-1	goal is to reduce solids loading into the ocean by means of going to the secondary treatment level at Point Loma WWTP. Reducing solids loading will occur if reuse of recycled water becomes a reality. The PA's are concerned not only with exposure to substantially higher capital costs and O&M costs and increases to these costs associated with going to the secondary level at the Point Loma WWTP at any capacity level.	
<i>Otay-41</i>	Section 2.1 Pg. 2-1	It is highly recommended that a similar stake holder and review process be followed in the City of Diego development of the new Wastewater Master Plan to be sure that the PA's interests are incorporated in the Wastewater Master Plan. This is important in that the Metro JPA will be asked to adopt the new Wastewater Master Plan.	Outside the scope of this study
<i>Otay-42</i>	Section 2.2 Pg. 2-2	Provide a copy of the City's WMP for review by JPA's	It is a standard procedure once the Wastewater Master Plan is complete it is usually routed to the Metro JPA for approval.
<i>Otay-43</i>	Section 2.2 Pg. 2-2	The report WMP focuses on MER as the single issue the City has in which to meet the current requirements of the modified NPDES permit. The commitment made to USEPA to reduce flow to the PLWTP is addressed in this report but the City doesn't need this report to take action.	The report provides a detailed path on how to offload the Point Loma Wastewater Treatment plant. Offloading the PLWTP without this plan will be limited and costly.
<i>Otay-44</i>	Section 2.2 Pg. 2-2	It is short sighted to assume that the Point Loma WWTP will remain as a advanced primary treatment facility at 240 mgd throughout the planning horizon for the May 2011 draft Metro WW Plan report. The WMP needs to consider that it is possible that treatment at the Point Loma facility could be required to go the secondary at some level. Planning for that possibility is important.	The Reuse Study assumes secondary treatment as a baseline and then compares it to the WWMP. A new cost methodology summary is included in Appendix H summarizing these considerations.
<i>Otay-45</i>	Section 2.2 Pg. 2-2	In the last paragraph first sentence the reference is to the current Wastewater Master Plan and not the new one under development? Please clarify.	Edits made

Appendix J
City of San Diego / Public Utilities
Recycled Water Study
Draft Report

NO.	REFERENCE	COMMENT	CITY RESPONSE
<i>Otay-46</i>	Section 2.3.2 Pg. 2-3	What is the estimated cost of the demonstration project and who is paying for it?	The total cost is \$11.8 million and it is being paid by the City of San Diego Citizens through a special assessment.
<i>Otay-47</i>	Section 2.3.4 Pg. 2-4	What are the conclusions of the 2010 Recycled Water Master Plan?	The recycled water master plan will be going to Council for approval in June of 2012 and once approved it will be available on-line for review.
<i>Otay-48</i>	Section 2.3.4 Pg. 2-4	Provide a copy of the 2010 Recycled Water Master Plan Update in the appendices or a link to where this can be found on the City's website. The statement "update is to evaluate opportunities to maximize non-potable reuse <u>if</u> indirect IPR are not pursued". It needs to be both to satisfy the Cooperative Agreement.	The existing and planned NPR as part of the Cooperative Agreement are included in the alternatives and this is represented by the top box in Figure 2-2. The 2010 RWMP is not needed for this purpose.
<i>Otay-49</i>	Section 2.4 Pg. 2-4	The Otay WD completed the Water Resources Master Plan Update in 2010 which includes non potable reuse supply for recycled water supply requirements and demand projections through ultimate build out. Please reference that document in this section for the Otay WD supply requirements from the South Bay Water Reclamation Plant are documented therein.	This section lists reports that the study team has reviewed and evaluated as part of this project. The team has not reviewed the OWD WRMP.
<i>Otay-50</i>	Section 2.4 Pg. 2-5	This is a repeat comment from TM-7 The Raftelis Financial Consultants Report needs to be distributed to the PA's for review and comment. The report should be revised to incorporate the PA's comments.	See response to previous comments
<i>Otay-51</i>	Section 2.4 Pg. 2-5	This is a repeat comment from TM-7 The Raftelis Financial Consultants Report second and third bullets points conflict with each other.	See response to previous comments
<i>Otay-52</i>	Section 2.4 Pg. 2-5	This is a repeat comment from TM-7 The Raftelis Financial Consultants Report should be submitted to all stakeholders including the PA's for review and comment. Comments received from the PA's and others on the initial draft study report need to be fully addressed in a timely manner and incorporated into a	See response to previous comments

Appendix J
City of San Diego / Public Utilities
Recycled Water Study
Draft Report

NO.	REFERENCE	COMMENT	CITY RESPONSE
		<p>final draft study report. The Final Draft Study Report should then be prepared and distributed to all stakeholders and the PA's for final review and comment.</p> <p>The Final Study Report should then be prepared and distributed to all stakeholders incorporating the comments.</p>	
<i>Otay-53</i>	Section 2.3.4 Pg. 2-4	Why is the implementation of future non-potable reuse concepts tied to the Demonstration project? There are projects the City could start today that will integrate with IPR if it moves forward in the future.	This graphic merely says that if the Demonstration project does not show IPR being feasible, the City would revisit a more NPR centric plan. Planned NPR to OWD still continues as noted in the top box.
<i>Otay-54</i>	Section 2.4 Pg. 2-5	The recommendation of a pricing structure that recovers all costs associated with producing and distributing recycled water doesn't address the wastewater agency's responsibility to treat wastewater to secondary. The current price structure does cover the City's costs, otherwise why did the City refund the PA's for revenues at the SBWRP that exceeded costs?	See response to previous comments
<i>Otay-55</i>	Section 2.4 Pg. 2-5	Recycled Water Study Participating Agency Options Metro JPA TAC provided an updated version of these options in March 2011. Explain how these options will be incorporated into this report and provide a copy with this study..	The PA white paper is included in Appendix I. The concepts were brought forward in the workshops and vetted with the stakeholder group.
<i>Otay-56</i>	Section 2.4 Pg. 2-5	The City does not have one recycled water system. The City's recycled water system consists of two distinct and unrelated systems. They are not a single system and there is no nexus between the two systems so please clearly state in the text within the Raftelis Report section the fact that the South Bay recycled water system is completely independent of the North City recycled water system!	See response to previous comments
<i>Otay-57</i>	Section 2.4 Pg. 2-5	Please include in an appendix the PA's Regional Opportunities to Reduce Flows at Point Loma Plant report. Also, include the City of San Diego response to the report.	The PA white paper is included in Appendix I.

Appendix J
City of San Diego / Public Utilities
Recycled Water Study
Draft Report

NO.	REFERENCE	COMMENT	CITY RESPONSE
<i>Otay-58</i>	Section 3.1 Pg. 3-1	The Study process overview description is incomplete. Please address that the TM's were distributed to the PA's for review and comment. Were all the PA's comments addressed? Please provide in an appendix all of the PA's comments on each of the TM's and include the Study team responses to each one of the comments and how they were addressed.	See response to previous comments
<i>Otay-59</i>	Section 3.4.1 Pg. 3-3	Bullet point 2 Will the goal of managing Metro System Costs be realized? If PA's opinions and recommendations are ignored, why should they contribute to City's plan?	PA representatives were involved throughout the Study and options were not ignored. Not all PA suggestions were included, but they were vetted in workshops and this is a multi-stakeholder process. The plan conclusions show regional benefits. Implementation steps outline important cost sharing discussions needed. Specific to OWD, expansion of South Bay provides desired NPR demands.
<i>Otay-60</i>	Section 3.4.1 Pg. 3-3	The City states that larger-scale projects are more cost effective, yet nowhere in this study do they prove this. In fact, the costing of the themes is so vague that there is no way to know that anything is correct. All of the back-up and calculation need to be verified to determine if these numbers are even relevant.	See TM8, Appendix F, and Appendix H. The process was covered in detail during workshops and stakeholder update meetings.
<i>Otay-61</i>	Section 4.2 Pg. 4-3	Provide a copy of the 2010 Recycled Water Master referenced in the report or provide the details mentioned in this section.	See response to previous comments
<i>Otay-62</i>	Section 4.2.1.1 Pg. 4-4	The reduction in reclaim sales is attributed to conservation, water efficiency, and the economic downturn. You should also mention weather impacts demands. The region has experienced both wetter and cooler weather which reduces recycled demand. Should the region experience hot, dry weather for several years in a row, recycled demands could increase dramatically. Wouldn't it be smart to be prepared to supply lower cost recycled water to meet these demands when return due	Weather can impact demands on a seasonal basis but the long term reduction is due to the factors listed. Recent weather data indicates it has been hotter and drier recently, not wetter and cooler.

Appendix J
City of San Diego / Public Utilities
Recycled Water Study
Draft Report

NO.	REFERENCE	COMMENT	CITY RESPONSE
<i>Otay-63</i>	Section 4.2.1.2 Pg. 4-5	to weather? Please list the current recycled water users connected to the South Bay Plant. Include the actual recycled water use of each user showing maximum flow, average flow, and minimum flow similar to table 4-1.	The demand breakout for South Bay is included in Table 5-3.
<i>Otay-64</i>	Section 4.2.1.4 Pg. 4-6	Please expand the description of the RWCWRF to include a description of the collection basin and the possibility of expansion for tertiary recycled water production in the future from 1.3 mgd to 2.6 mgd, and ultimately 3.9 mgd.	OWD expansion possibility noted. Basin details not provided and beyond the limits of the Study, which doesn't include any basin descriptions.
<i>Otay-65</i>	Section 4.2.2 Pg. 4-7	The City does not have one recycled water system. The City's recycled water system consists of two distinct and unrelated systems. They are not a single system and there is no nexus between the two systems so again revise text to so state these facts specifically in the text!	See response to previous comments
<i>Otay-66</i>	Fig. 4-7 Pg. 4-7	Identify existing service area boundaries for north and south systems. The two systems are separate and the services areas are not connected. This distinction is important since the City recycled water cost structure is proposing a single cost structure that would have the south bay rate payers subsidize the north system inconsistent with Prop 218 requirements.	See response to previous comments
<i>Otay-67</i>	Section 4.4.1 Pg. 4-10	The reduction in flow is an important element of meeting the intent of the waiver and the Cooperative Agreement. Suggest adding a simplified graph or graphic to highlight the reduction in flows over the last 10 years. This section is difficult to follow with all of the different flow data presented.	Figure 4-10 has been revised to show the min/max/and average annual flow. Additional text has been added to this section to clarify the flow projections.
<i>Otay-68</i>	Section 4.4.3 Pg. 4-11	For the North City Plant and South Bay Plant clearly define the recycled water production values as annual average rates or what ever they are.	This section does not discuss recycled water production. See chapter 5, which includes an annual graphic for each plant.
<i>Otay-69</i>	Section 4.4.3 Pg. 4-11	This section needs to include the following information: The SBWRP during the summer months cannot keep up	Interim flow diversions will not be discussed in this study. Otay and the City have discussed the

Appendix J
City of San Diego / Public Utilities
Recycled Water Study
Draft Report

NO.	REFERENCE	COMMENT	CITY RESPONSE
		with the peak demands for recycled water resulting in almost zero discharge to the SBOO. Demands already exceed capacity. OWD recently had to supplement with potable water since the SBWRP could not keep up with demand.	funding of the Salt Creek diversion and those discussions will be held outside of this study as previous discussed.
<i>Otay-70</i>	Section 4.4.3 Pg. 4-11	The Otay WD in May of 2007 completed the construction of recycled water pipeline, reservoir, and pump station to link the existing Otay WD recycled water system to the South Bay Plant. The system link allowed for access to the South Bay Plant recycled water supply. Prior to that the Otay WD was supplementing the recycled water supplies from the RWCWRF with imported treated water supplied by the SDCWA. The Otay WD 100% funded the approximately \$43 million dollar supply link. Please add this information to the text.	The details of the wholesale agency systems are not included in this study. It is recognized that OWD has made NPR investments. The plan includes NPR flows for OWD as summarized below.
<i>Otay-71</i>	Section 4.4.3 Pg. 4-11	The timeline for wastewater flow diversions to the South Bay Plant to meet Otay WD non-potable recycled water monthly supply needs need to line up with the monthly supply requirements and demand levels previously provided by Otay WD staff to the Study team. Nearer term wastewater diversions to the SBWRP need to be accomplished in order to achieve the non-potable recycled water demand levels within the Otay WD jurisdiction on a monthly basis. This needs to be addressed and discussed within the text.	Interim flow diversions will not be discussed in this study. Otay and the City have discussed the funding of the Salt Creek diversion and those discussions will be held outside of this study as previous discussed.
<i>Otay-72</i>	Section 4.4.3 Pg. 4-11	The take values in acre feet on an annual basis within the SBWRP agreement between the City and Otay are not demands they are simply numbers. If Otay WD does not take the stated quantity on an annual basis from the SBWRP Otay WD would have to pay for any difference between the take annual quantity and the actual annual quantity taken provided the City is operating under the premise per terms of the agreement that sufficient wastewater flows are being sent to the SBWRP to	The demands planned for are from OWD provided data. See Otay 82 for specifics on inclusions.

Appendix J
City of San Diego / Public Utilities
Recycled Water Study
Draft Report

NO.	REFERENCE	COMMENT	CITY RESPONSE
		<p>produce 10 mgd of tertiary water which is available for sale at the SBWRP which is not the case. Also, if the City limits the Otay WD take to 6 mgd in the summer months then the annual contract take amounts cannot be achieved for the annual contract amounts within the agreement were developed under the assumption that supply from the SBWRP to Otay WD will in fact exceed 6 mgd in the summer months. There is a clear disconnection between the 6 mgd so called City obligation to supply and the annual take values within the agreement. Consequently, sufficient quality wastewater must be diverted to and treated by the South Bay Plant when the supply is needed to meet the conditions of the agreement. Please address these facts within the text.</p>	
<p>Otay-73</p>	<p>Section 4.4.3 Pg. 4-11</p>	<p>The study states: The City and Otay are also separately discussing interim diversions to meet peak summer day demands. This statement is true, but the result of the study by Guann Hwang was that the Salt Creek diversion was too expensive and that if Otay wanted it done then Otay would have to pay for it. Otay did not agree with the method of calculation and asked for the back-up to the calculations. To-date Otay has not received this data. Otay recently had to supplement recycled water with Potable in July 2011 because the production at the SBWRP was not sufficient to meet the demands. At the same time, the City holds Otay accountable to the Take-or-Pay portion of the agreement to purchase recycled water. Doesn't it seem unfair to require Otay to pay for the infrastructure to get enough flows to SBWRP <u>and</u> hold Otay hold Otay accountable to the Take-or-Pay? Not only does this seem unfair, but it is potentially breach of contract for the wholesale sales to Otay from SBWRP.</p>	<p>Interim flow diversions will not be discussed in this study. Otay and the City have discussed the funding of the Salt Creek diversion and those discussions will be held outside of this study as previous discussed.</p>
<p>Otay-74</p>	<p>Section 4.4.4</p>	<p>Change second sentence to read</p>	<p>Revised.</p>

Appendix J
City of San Diego / Public Utilities
Recycled Water Study
Draft Report

NO.	REFERENCE	COMMENT	CITY RESPONSE
<i>Otay-75</i>	Pg. 4-11 Fig. 4-13 Pg. 4-14	These projections are important... Add in intermediate diversions, i.e. Salt Creek, not just the single ultimate diversion.	Interim flow diversions will not be discussed in this study. Otay and the City have discussed the funding of the Salt Creek diversion and those discussions will be held outside of this study as previous discussed.
<i>Otay-76</i>	Section 4.4.5 Pg. 4-15	Missing from this water loss process and Fig. 4-14 on the advanced treatment icon is the evaporation from the reservoir, potential loss from water runoff during a rain event causing the water to spill from the reservoir (lost water), and water loss from the next treatment process to turn it into potable water. The potential loss of water is after the advance treatment stage when potentially huge volumes can be lost. Without completing the full cycle, this section is not complete. Also add the % lost at each stage. By losing 13-15% with the advance treatment, the reader will understand the value of non-potable recycled water, there is simply more to use and less waste.	The figure has been revised to show the percentages of the losses. This figure shows the losses within the treatment processes, not evaporation from a reservoir or losses in an irrigation system for NPR.
<i>Otay-77</i>	Section 5.1 Pg. 5-1	Please be clear that the first priority is to determine and supply the existing and planned non-potable recycled water demands and that the remaining amount of tertiary treated water available for further treatment and recycling are for indirect potable reuse.	Non-potable and indirect potable reuse were evaluated without prioritization. Regardless, OWD's desired demands are included in every alternative in Chapter 8.
<i>Otay-78</i>	Section 5.1 Pg. 5-1	Revise second sentence to include increasing supplies to existing wholesale customers such as Otay WD and that the existing South Bay Plant could be expanded or a new tertiary facility can be constructed near the existing South Bay Plant to meet non-potable recycled water demands.	OWD's desired demands are included in every alternative in Chapter 8. Additional edits here are not essential.
<i>Otay-79</i>	Section 5.2 Pg. 5-1	For both NCWRP and SBWRP is the City really pursuing the expansion of recycled water as required by the waiver?	The City is in line with the waiver requirements.
<i>Otay-80</i>	Section 5.2 Pg. 5-1	Please be clear that the Otay WD, City of Poway, and Olivenhain WD are wholesale customers with wholesale	Revised.

Appendix J
City of San Diego / Public Utilities
Recycled Water Study
Draft Report

NO.	REFERENCE	COMMENT	CITY RESPONSE
		<p>connections. Revise the text.</p> <p>It must be clear that the take values in acre feet on an annual basis within the SBWRP agreement between the City and Otay are not demands they are simply numbers. The timeline for wastewater flow diversions to the South Bay Plant to meet Otay WD non-potable recycled water monthly supply needs need to line up with the monthly supply requirements and demand levels previously provided by Otay WD staff to the Study team. Please use the recycled water demand numbers that Otay WD provided for the baseline and projected demands.</p>	<p>The Otay demand numbers have been used in this study and are included in table 5-3.</p>
<i>Otay-81</i>	Section 5.2 Pg. 5-1	<p>The demands shown in the table do not reflect the Otay WD demands values. Please revise. The 1.8 mgd number is to low for 2026 and the 6.0 mgd simply is the value within the supply agreement. Use demands not contract numbers for Otay WD. Please provide in the table showing the City's and Otay WD's values separately for the South Bay Plant.</p>	<p>See Table 5-3 for OWD breakdown. This includes OWD provided demands.</p>
<i>Otay-82</i>	Section 5.3.2 Pg. 5-4	<p>For the Otay WD include the total ultimate build out irrigation demand number of about 9.0 mgd annual average is which about 10,000 acre feet per year within the text. The peak month demand would be about 18 mgd for the Otay WD.</p>	<p>The study includes 9 mgd of average annual demands for OWD (not including Chapman as noted) as shown in Table 5-3 (this includes existing demands, two levels of planned demands, and future demands just for OWD). Peak month totals are shown in Figure 5-5. Figure 5-5 also notes additional capacity available that could be used to meet the difference between peak week and peak day demands. (as a point of clarification, OWD previously cited 18 mgd as the peak day not peak month – OWD provided historical peak month factors which were lower than 2.0)</p>
<i>Otay-83</i>	Section 5.3.3 Pg. 5-4	<p>The Otay WD intends to operate the RWCWRF at full capacity to the greatest extent possible to produce about</p>	<p>A similar but lower value was included in this study per previously received guidance (see Table 5-3</p>

Appendix J
City of San Diego / Public Utilities
Recycled Water Study
Draft Report

NO.	REFERENCE	COMMENT	CITY RESPONSE
		1,100 acre feet per year or 1 mgd annual average production of recycled water. Please use this value in the Study.	footnote). Slightly higher usage from Chapman is not an issue since it will just mean that South Bay needs to provide a little less than currently projected.
Otay-84	Section 5.4 Pg. 5-5	Non-potable water is the most cost effective water available. IPR water that needs to go through advance treatment through new dedicated pipelines and pump stations and then through a whole new water treatment process cannot be shown to be more cost effective than non-potable water. To be consistent with section 5.4.1, the last sentence should be modified to read “these factors shaped the approach to utilize non-potable first with the balance of the new reuse coming from large IPR projects.	The sentence in the report is consistent with the findings of this study. It is recognized OWD is a strong proponent of NPR and the plan includes Otay’s desired NPR flows.
Otay-85	Section 5.4 Pg. 5-5	In the second paragraph include a few sentences that include the planned and contracted totals and compare with the reuse target of the Study. Please include values for a measure of relative comparison.	Table 5-5 includes a detailed demand breakdown.
Otay-86	Section 5.4 and Fig. 5-3 Pg. 5-5	The City is projecting very little growth in non-potable water use over the 30 year timeframe of the graphic. This indicates the City will stop expanding their system at the expense of very expensive IPR water. Has the City considered a set of “designer water” similar to what west basin has done to use as much of the non-potable water as possible? The highest and best use is non-potable water with IPR using the left over water. The report is written and the data appears skewed to place IPR over all other uses of recycled water.	The Designer Water concept was discussed at a workshop and determined not to be appropriate for San Diego. West Basin has groundwater and multiple industrial uses including refineries. San Diego does not have these opportunities. The data is not skewed. The evaluation has shown that IPR should be pursued as described in this report. It is recognized that OWD is a proponent of NPR and OWD’s NPR demands are included in this plan.
Otay-87	Fig. 5-5 Pg. 5-8	Graphic is misleading suggesting there is adequate wastewater available to meet demands today. That isn’t accurate. A line needs to be added to reflect current capacity at the top of the 2009 existing non-potable recycled water demand curve since that accurately reflects the current situation. This line can be labeled	Interim flow diversions will not be discussed in this study. Otay and the City have discussed the funding of the Salt Creek diversion and those discussions will be held outside of this study as previously commented on.

Appendix J
City of San Diego / Public Utilities
Recycled Water Study
Draft Report

NO.	REFERENCE	COMMENT	CITY RESPONSE
		"existing capacity without diversion". That is the reasoning behind the discussions with the City to initiate the Salt Creek diversion. Either way, Salt creek would be diverted, not sent to SV08 to pump it back up to the plant.	
<i>Otay-88</i>	Fig. 5-5 Pg. 5-8	To determine how much SBWRP can offload PLWTP, more information on the capacity of Lower Otay to take IPR water is needed. The excess tertiary available may not be of use if the reservoir has a capacity limit.	See discussion of reservoir capacity in TM 5. There is enough wastewater planned at South Bay for both the IPR project and OWD desired demands. An implementation step is also included to address these points.
<i>Otay-89</i>	Section 6.1 Pg. 6-2	Last paragraph appears to indicate going to IPR will reduce costs. Since a separate treatment process. Separate pipelines, pump stations, and a second full pass for water treatment prior to use. No information is provided to support the last sentence that non-potable... "impacts costs". Section 5.4 doesn't describe cost comparison.	The evaluation in this Study has shown that IPR costs less than an IPR/NPR project related Alternative B2 with and without a Rancho Bernardo NPR expansion. It is recognized OWD is a strong proponent of NPR and the plan includes Otay's desired NPR flows.
<i>Otay-90</i>	Section 6.1 Pg. 6-2	States: Non-potable recycled water also requires maintaining a separate accounting and billing system. This is not true. Yes, you do need a separate account number to track revenue and cost of recycled but not a whole system. Otay uses fund and account numbers to properly segregate potable, recycled and sewer.	Edits made to clarify that separate accounting and billing is required, not necessarily new systems
<i>Otay-92</i>	Section 6-2 Pg. 6-2	Improved water quality for one constituent (TDS). How about for others like boron? Wastewater boron levels are higher as a result of the household cleaning products and other sources used by customers. What is the expected concentration after advanced treatment? Will there be a concentration as a result of several passes through the wastewater plant? What about pharmaceuticals?	The demonstration project is ongoing and results will be available after the project is complete.
<i>Otay-93</i>	Table 6-1 Pg. 6-4	The assumption on this table is that the full capacity is available however 41,000+/- 6,000 AF would be more likely for flood control. The Lower Otay reservoir supplies the Lower Otay WTP. The current ADD is 20 MGD and the demand by 2035 is estimated to be 35 MGD.	There are follow-up steps related to the Otay IPR project. Regardless, the plan includes OWD's desired NPR flows without changes to the IPR plan at Otay Lakes.

Appendix J
City of San Diego / Public Utilities
Recycled Water Study
Draft Report

NO.	REFERENCE	COMMENT	CITY RESPONSE
		Currently the City only needs 8 to 10.7 MGD of raw water delivered to the reservoir to provide the 20 MGD demand. The rest is supplied from storm runoff. Given the existing demand will use up the storage within a single year, it isn't clear that this reservoir is a viable candidate for IPR.	
<i>Otay-94</i>	Section 6.3 Pg. 6-3	The Study should discuss the potential impact of existing and future potable water demands at, for example the Otay WTP, relative to the reservoir augmentation quantity potential upon detention time and customer consumption percentage of non potable reuse water.	See discussion in TM 5. The planned IPR project is less than 50% of the projected water demands.
<i>Otay-95</i>	Section 7.2 Pg. 7-2	Bullet points at bottom of the page; Comparing IRP as the most ideal compared to non-potable because you are wasting 15% through the RO process actually makes the case that non-potable is more valuable than IRP. You get 15% more to reuse.	IPR water use is unlimited. NPR is limited to specific non-potable reuse opportunities. Water used for irrigation is not recovered. IPR is recovered and used again.
<i>Otay-96</i>	Section 7.2 Pg. 7-2	Indirect potable reuse opportunities were sized based upon available wastewater supplies less non-potable reuse identified in Chapter 5 for the indirect potable reuse capacity potential. Revise text in first paragraph.	The two were sized in coordination with each other. Neither was given preference. This should be a non-issue since the plan provides OWD it's desired NPR totals.
<i>Otay-97</i>	Section 7.3.4 Pg. 7-6	States: Ability to peak during summer, that the Harbor Dr site could provide more water to local drinking water treatment plants when demands are the highest. If water need to sit in San Vicente for two years before you could pull it out, treat it again and put it into the potable distribution system, how would this help seasonal peaking?	The injection into San Vicente and the flows out of San Vicente are being modeled as part of the Demonstration Project. The system is dynamic and the model is being used in coordination with developing the regulations.
<i>Otay-98</i>	Table 7-1 Pg. 7-8	None of the PA's suggestions are included on this list. What happened to the idea of Padre Dam doing IPR to San Vicente? Is the Mission Gorge Water Treatment Plant, Padre Dam's plant	PA representatives were involved in the screening sessions and had a hand in developing the options presented. Some options were not advanced. The Mission Gorge option was added based on PA support. The Mission Gorge plant is currently considered independent of the PDMWD plant, but

Appendix J
City of San Diego / Public Utilities
Recycled Water Study
Draft Report

NO.	REFERENCE	COMMENT	CITY RESPONSE
<i>Otay-99</i>	Section 7-5 Pg. 7-15	Option A, B, and C should all include maximizing non-potable use for many reasons. It is cheaper water to produce. Also less of it is wasted through the advance treatment process (15%), evaporation (5-10%), or loss during a storm event (0 to 100%).	there is an implementation step in 8.5 to look at potential benefits and impacts of this approach. This section captures the options evaluated in the workshop. Doing less NPR was a valid consideration to weigh against more NPR. Regardless, every alternative in Chapter 8 includes South Bay C2 and it is recognized that OWD favors this scenario.
<i>Otay-100</i>	Fig. 7-10 Pg. 7-15	Why is the City assuming in Options A & C that they will only provide 50% of Otay's demands and in Option B zero percent of Otay's demands Otay has invested \$43 million just to connect to SBWRP, plus millions more to build a distribution system. Why would you even consider not serving your lowest cost customers (recycled) first prior to doing IPR. Option C2 is the only viable option.	This section captures the options evaluated in the workshop. Doing less NPR was a valid consideration to weigh against more NPR. Regardless, every alternative in Chapter 8 includes South Bay C2 and it is recognized that OWD favors this scenario.
<i>Otay-101</i>	Section 7-5 Pg. 7-15	With the City only including the Otay WD contracted flows in the South Bay Concepts it limits the Otay WD ability to develop recycled water markets beyond current demand levels and does not assure the Otay WD will have enough recycled water supply to meet existing and future demands from the SBWRP. The South Bay Concepts should assume that the South Bay Plant will meet all of Otay's existing and future planned recycled water demands and not limit those uses. The existing Otay WD recycled water system is sized to acquire at least 18 mgd from the South Bay Plant hence the City only needs to comment to providing sufficient supply to Otay WD from the South Bay Plant. With the City only including what is called the baseline demands this is inconsistent with the evaluation criteria established for the Study and the primary goal of the Study. Any option which does not meet the Otay WD recycled water supply needs from the South Bay Plant should be considered as not addressing the intent of the Cooperative Agreement.	Section 7 includes all the concepts considered. A sentence was added to Section 7.5 to clarify that C2 was included in each Alternative.

Appendix J
City of San Diego / Public Utilities
Recycled Water Study
Draft Report

NO.	REFERENCE	COMMENT	CITY RESPONSE
Otay-102	Section 7-5 Pg. 7-15	Only Option C2 as shown meets all requirements. Figure 7-10 for Option C the Otay WD recycled water demands should first be met at 100% and the remaining recycled water should be used for Otay Lakes indirect potable reuse. In fact the Otay WD recycled water demands should take precedence over the indirect potable reuse demands for the delivery systems are in place and it is less costly to produce tertiary water. The Otay WD projects the need for 18 mgd from the South Bay Plant to meet summer irrigation demands at ultimate build out.	Every alternative in Chapter 8 includes South Bay C2 with flows based on values provided directly by OWD. The study includes 9 mgd of average annual demands for OWD (not including Chapman as noted) as shown in Table 5-3 (this includes existing demands, two levels of planned demands, and future demands just for OWD). Peak month totals are shown in Figure 5-5. Figure 5-5 also notes additional capacity available that could be used to meet the difference between peak week and peak day demands. No changes are needed to the Otay Lakes IPR flow to accomplish this.
Otay-103	Table 7-4 Pg. 7-15	Table should use same labels and be in the same order as Table 4-2	Edits made
Otay-104	Section 7.5.1 Pg. 7-16	Talks about the City, Otay and Chula Vista discussing interim diversions. As stated above, this is not happening in a productive, meaningful or sincere manner.	This item needs to be addressed outside this study.
Otay-105	Table 7-5 Pg. 7-17	Table should use same labels and be in the same order as Table 4-2	Edits made
Otay-106	Section 7.5.2 Pg. 7-18	For the South Bay B and C Options reduce the indirect potable reuse to 11.5 mgd and 13.0 mgd respectively and increase non-potable recycled water production to 9 mgd. That is what should be analyzed for this is the least costly for both options.	This revision does not need to occur to meet OWD demands. See previous responses.
Otay-107	Section 8.1.1 Pg. 8-1	Water reuse is both non-potable and IPR per Section 1.6. Replace IPR with non-potable and IPR in the next to last sentence.	Water reuse was changed to indirect potable reuse in the last sentence.
Otay-108	Section 8.1.2 Pg. 8-2	This section brings up the issue of blending. How will this water be blended? How much of a change in TDS will be evident in the product water? Suggest an estimation of this be provided in this report. Looking at boron levels in	Added some language about this benefit based rough +/- 50/50 blend with 60 TDS AWPf water leading to reductions up to 50%.

Appendix J
City of San Diego / Public Utilities
Recycled Water Study
Draft Report

NO.	REFERENCE	COMMENT	CITY RESPONSE
		the product water when Poseidon goes online will be a concern in the future, especially during the winter months when Poseidon could make up nearly 100% of the water delivered from CWA.	
<i>Otay-109</i>	Table 8-1 Pg. 8-3	Identify the source of the \$1.053 billion estimate. Is this the low end of the estimate or the high end?	Totals revised per Sept 2011 WWMP. See Appendix H.
<i>Otay-110</i>	Section 8.2 Pg. 8-5	Please add a sentence or two to state that the costs shown in tables 8-4 through 8-10 do not include the O&M and any other costs for treatment at the Otay WTP or the Alvarado WPT to produce treated water.	Added.
<i>Otay-111</i>	Section 8.2 Pg. 8-5	Please provide in an appendix the detail cost information that support information in tables 8-4 through 8-10.	See TM8, Appendix F, and Appendix H.
<i>Otay-112</i>	Section 8.3 Pg. 8-12	In table 8-12 please include some text about the South Bay C2 Option.	The same South Bay C2 option is included an all alternatives. Therefore, it does not require comparison in this table. A footnote was added for this.
<i>Otay-113</i>	Section 8.4.1 Pg. 8-14	Soft costs are 50% of what?	50% of the capital costs
<i>Otay-114</i>	Section 8.4.3 Pg. 8-15 Pg. 8-16	Salt Reduction Credit of \$100 is too high without benefit of a study that can quantify the improvement.	A previous MWD study provided a larger Salt Credit (\$250/AF) than what was used in this Study (\$100/AF). See discussion in TM 8.
<i>Otay-115</i>	Table 8-16 Pg. 8-19	The City states that larger-scale projects are more cost effective, yet nowhere in this study do they prove this. In fact, the costing of the themes is so vague that there is no way to know that anything is correct. All of the back-up and calculation need to be verified to determine if these numbers are even relevant.	See TM8, Appendix F, and Appendix H. The process was covered in detail during workshops and stakeholder update meetings.
<i>Otay-116</i>	Table 8-16 Pg. 8-19	Without any supporting documentation it is unreasonable for the PAs to support any of these cost figures. Explanations of methods, sources, and calculations are needed to vet these numbers. Where did the calculation	See TM8, Appendix F, and Appendix H.

Appendix J
City of San Diego / Public Utilities
Recycled Water Study
Draft Report

NO.	REFERENCE	COMMENT	CITY RESPONSE
Otay-117	Section 8.4.4 Pg. 8-19	for Salt Credit come from? Please provide in an appendix the detail cost information that support information in tables 8-16 and 8-17.	See TM8 and Appendix F in this report.
Otay-118	Fig. 8-9 Pg. 8-21	Implementation for the North City and South Bay should be parallel, not sequential to be consistent with the earlier schedules. Re-label North City initial IPR as Demonstration Project and add another box for North City IPR parallel to South Bay IPR	The figure has been revised to show North City and South Bay occurring parallel.
Otay-119	Section 8.5.2 Pg. 8-21	It should be addressed within the Study that the CWA and its member agencies are major stakeholders in the concept of IPR within particularly the San Vicente Reservoir. The CWA and its member agencies should be approached to discuss many related topics some of which include public perception, public outreach, IPR water ownership, who pays for what, etc. The outcome of the CWA and its member agency stakeholder thoughts, approaches, positions, etc. should be included within the Study.	CWA has been an active stakeholder in this study.
Otay-120	Section 8.5.4 Pg. 8-22	Include the South Bay Plant expansion, pump station, and transmission main to Otay Lakes in the list.	This has been added.
Otay-121	Section 8.5.4 Pg. 8-22	Include discussion on benefit sharing on water produced and other benefits.	See 8.5.5
Otay-122	Section 8.5.5 Pg. 8-23	Frame work concept descriptions are confusing, i.e. Water Expense versus Wastewater Expenses and 50-50% Split. These are two different concepts but appear to address the cost of recycled water. How will Prop 218 fit into these discussions?	Cost sharing discussions are an implementation step as outlined in Section 8.5.5. Discussion of prop 218 may be included in this future implementation step.
CV-1	Section 2.2, page 2-2	Recommend expanding the discussion of the annual mass emissions at the PLWTP to include a graph which shows the permit requirements, the actual amount each year for the past 10 years, and the estimated amounts for secondary at 240 mgd, secondary at 200 mgd, secondary at 100 mgd, CEPT at 240 mgd, CEPT at 200	Added reference to appendix B. Added table to appendix B.

Appendix J
City of San Diego / Public Utilities
Recycled Water Study
Draft Report

NO.	REFERENCE	COMMENT	CITY RESPONSE
CV-2	Section 8.1.4, page 8-2	mgd and CEPT at 100 mgd. This section states that the upper limit capacity of the PLWTP was reduced from the permitted capacity of 240 mgd to 200 mgd based on reduced flow estimates in 2050. This is a very significant assumption and should be backed up with detailed calculations as part of this document. In addition, the implication is that subsequent cost estimates in the document for secondary upgrade cost savings are based on a comparison of secondary costs at 200 mgd not 240 mgd. Is that true? Do these estimates assume primary treatment facilities like sedimentation basins over that needed for 200 mgd or for 100 mgd will be removed to make room for secondary facilities? If so, a potential downside is the loss of peaking capacity for primary treatment.	Point Loma flows have been updated per the City's September 2011 Draft Wastewater Master Plan. The comparison between the Point Loma Plant with the reuse projects in this study has been updated. See Chapter 8, Appendix B and Appendix H.
CV-3	Table 8-14, page 8-16	It is not clear if the projected savings for the 100 mgd Point Loma Secondary Treatment Upgrade scenario is in comparison to the costs for a 240 mgd secondary upgrade or a 200 mgd secondary upgrade as identified in Section 8.1.4.	See CV-2. Details in Appendix H.
CV-4	Appendix C	This Appendix should include a description of OPRA as it affects wastewater.	OPRA background added to C.2.
PD-1	Pg ES-8	Table shows Padre Dam Water Recycling Facility has a 2.3 mgd design capacity. The current design capacity is 2.0 mgd. Revise Table to show a 2.0 mgd design capacity	Revised.
PD-2	Pg ES-10	Under Indirect Potable Reuse Opportunities. Helix Water District is also considering an option to send advanced treated recycled water to their Lake Jennings Reservoir as part of a reservoir augmentation IPR project. Add a discussion in this section on use of Lake Jennings for an IPR project.	Added an implementation step to re-evaluate reservoirs as those studies evolve.
PD-3	Pg ES-12	On the Figure for Reservoirs, Groundwater Basins and Proposed Projects add the Santee Basin which is	Added an implementation step to update information on groundwater basins.

Appendix J
City of San Diego / Public Utilities
Recycled Water Study
Draft Report

NO.	REFERENCE	COMMENT	CITY RESPONSE
PD-4	Pg ES-13	<p>currently under study by the Bureau of Reclamation for Padre Dam Municipal Water District. Preliminary planning number put the capacity of the first site considered to be between 1.5 mgd and 3 mgd of groundwater recharge capacity. Add the Santee Basin to the Figure on Pg ES-12 and to the appropriate section for discussion.</p> <p>On the Table showing Indirect Potable Reuse Projects Advanced add Lake Jennings to this list. Lake Jennings is close to the location of the proposed pipeline conveying advanced treated recycled water to the El Monte Valley Project and the Levy Treatment Plant which gives this project potential. Add Lake Jennings to the like of Potable Reuse Projects advanced.</p>	Added an implementation step for this.
PD-5	Pg ES-14	<p>The bulleted text, “3” Sub-Alternative states “Alternative “B3” is the same as Alternative “B2”, except that it included a small plant in Mission Gorge to collect, treat and convey water to the San Vicente Reservoir. This adds a fourth plant, but it is the closest location to the San Vicente Reservoir.” Alternative B3 does not add a fourth plant but expands the Padre Dam WRF currently planned to serve local non-potable water demand plus the El Monte Groundwater Project. Remove text that says a fourth plant would need to be constructed (enlargement of the currently planned Padre Dam WRF from 10 mgd to 18.7 mgd would be needed).</p> <p>The current plan for Padre Dam WRF to accommodate non-potable and El Monte demands is to expand the existing 2.0 mgd plant to approximately 10 mgd. All alternatives in this study require that a minimum 10 mgd plant be constructed to accommodate these flows. In order to produce 6.8 mgd of IRP water to be sent to San Vicente (under alternative B3) an additional 8.7 mgd of plant influent capacity would be needed for a total of</p>	<p>There is a difference in assumptions here. The MG plant and the PDMWD efforts are not considered combined at this point of the study. They are considered independent. An implementation step has been added to evaluate this area in more detail to look at costs, benefits and impacts.</p> <p>The Mission Gorge plant is handled the same as North City and South Bay. New plants were counted when and AWT was added. The “1” alternatives also add an additional plant and a comment has been added to that description to be equitable.</p>

Appendix J
City of San Diego / Public Utilities
Recycled Water Study
Draft Report

NO.	REFERENCE	COMMENT	CITY RESPONSE
		18.7 mgd raw wastewater influent capacity.	
PD-6	Pg ES-16 & 17	El Monte Valley Groundwater Basin Project is an additional 5 mgd off load to Point Loma. El Monte Valley Groundwater Basin flow of 5 mgd is not shown on Reuse by Phase Graph, Reuse Per Plant Graph, Implementation Schedule Graph, Table showing Off Loads, and Table showing Capital and O&M Costs per Phase. Add El Monte Valley Groundwater Recharge Project to all Graphs and Tables in this Section.	The El Monte Valley project is shown on the Metro System flows graph. The other graph is for projects costed and led by the City. El Monte Valley is properly accounted and the City is supportive of your project.
PD-7	Pg ES-18 & 19	El Monte Valley Groundwater Basin Project is an additional 5 mgd off load to Point Loma. El Monte Valley Groundwater Basin flow of 5 mgd is not shown on Reuse by Phase Graph, Reuse Per Plant Graph, Implementation Schedule Graph, Table showing Off Loads, and Table showing Capital and O&M Costs per Phase. Add El Monte Valley Groundwater Recharge Project to all Graphs and Tables in this Section.	See PD-6
PD-8	Pg ES-20 & 21	El Monte Valley Groundwater Basin Project is an additional 7 mgd off load to Point Loma. El Monte Valley Groundwater Basin flow of 5 mgd is not shown on Reuse by Phase Graph, Reuse Per Plant Graph, Implementation Schedule Graph, Table showing Off Loads, and Table showing Capital and O&M Costs per Phase. By combining the offload that would be generated by the additional demands of El Monte, PDMWD's RW demands, PDMWD facility could be expanded to 18 to 20 MGD to achieve the economy of scale comparable to other options outlined in this study. Add El Monte Valley Groundwater Recharge Project to all Graphs and Tables in this Section.	See PD-6
PD-9	Pg ES-23	With regard to the Salt Credit of \$100/AF, all water customers within the region will benefit from reduced salt concentration. Note that the IPR water placed into San Vicente Reservoir is a shared facility with the CWA and the City of San Diego. Reduction of salt would be a	The need to determine the fair share responsibilities for the Salt Credit has been added to the Cost Sharing discussion in 8.5.7.1

Appendix J
City of San Diego / Public Utilities
Recycled Water Study
Draft Report

NO.	REFERENCE	COMMENT	CITY RESPONSE
PD-10	Pg ES-24	<p>benefit to the region; therefore, salt credit must be paid for by all customers that receive the benefits of reduced salt in the potable water supply. Additionally, CWA should be consulted extensively regarding the viability of providing this credit to the project. Address regional impacts of implementing salt credit in the fairest and reasonable manner including the CWA.</p> <p>Under discussion on Alternative B3 it states that the technical complexity is “High (4th Water Reclamation Plant/Advanced Water Purification Facility at Mission Gorge)”, and that the “Mission Gorge Plant is relatively small due to limited tributary wastewater flows.”</p> <p>Alternative B3 does not add a fourth plant but expands the Padre Dam WRF currently planned to serve local non-potable water demand plus the El Monte Groundwater Project.</p> <p>The current plan for Padre Dam WRF to accommodate non-potable and El Monte demands is to expand the existing 2.0 mgd plant to approximately 10 mgd. All alternatives in this study require that a minimum 10 mgd plant be constructed to accommodate these flows. In order to produce 6.8 mgd of IRP water to be sent to San Vicente (under alternative B3) an additional 8.7 mgd of plant influent capacity would be needed for a total of 18.7 mgd raw wastewater influent capacity. Expanding the plant from 10 mgd to 18.7 does not add technical complexity nor is it a small plant with regard to other plants proposed under this alternative. Revise text.</p>	<p>There is a difference in assumptions here. The plants are not considered combined at this point of the study. They are considered independent. An implementation step has been added to evaluate this area in more detail to look at costs, benefits and impacts.</p>
PD-11	Pg ES-26	<p>The graphic at the top of the page does not show the El Monte Valley Groundwater Recharge Project. Add the El Monte Project to this graphic.</p>	<p>Added</p>

Appendix J
City of San Diego / Public Utilities
Recycled Water Study
Draft Report

NO.	REFERENCE	COMMENT	CITY RESPONSE
PD-12	General	This study still did not discuss how much IPR Water San Vicente can take. What is the City's contingency plan if the regulatory framework is more restrictive? Where is the offload then? Address.	The background for the San Vicente project sizing is provided in TM 5 and summarized in Chapter 6. A technical implementation step has also been added.
PD-13	General	There are significant avoided costs by diverting flow into Padre Dam's facility including pending upgrades and rehabilitation of the sewer force main and Mission Gorge Pump Station. This cost avoidance should be recognized in the report as they represent significant savings to the Participating Agencies. Add avoided cost for not proceeding with the rehabilitation of the force main and Mission Gorge Pump Station with alternative B3.	See response to previous comments.
PD-14	General	Note that the proposed expansion at Padre Dam in association with the El Monte Project would result in offloading of the PLWTP by 5 mgd. This would result in significant cost savings to the Participating Agencies and the City of San Diego. Costs for offloading the PLWTP by expanding the Padre Dam facilities to recharge the El Monte Project should be recognized in all themes presented in this report. Discuss sharing of cost savings with Padre Dam MWD as related to capital and O&M costs.	El Monte Valley is recognized as an offload to the PLWTP and is shown in the Metro offload graphs for all themes. The costs and benefits (savings) for El Monte Valley are not shown since they are not led by the City. The follow-on cost sharing discussions are intended to fairly consider the El Monte Valley project and its benefits to the City and PA members.
PD-15	General	Land acquisition and environmental difficulties for the Harbor Drive site are significant. The Padre Dam facility already has land and has treated wastewater at its current location for over 50 years. Therefore, expansion of the Padre Dam facility would have less environmental and community impacts than the Harbor Drive option. Provide a more realistic cost estimate on environmental related mitigation cost for the Harbor Drive option vs. the Padre Dam Expansion option. Pumping costs from Harbor Drive to San Vicente are	Siting: The City has existing land at Harbor Drive so land acquisition may not be significant. The site houses the largest wastewater pump station in San Diego and has blighted structures. Pumping: Agree that pumping from Mission Gorge is less than from Harbor Drive. This has been accounted for in the cost model. Harbor Drive has economy of scale. Further cost refinements can occur as part of detailed siting work in the implementation steps included in Section 8.5.

Appendix J
City of San Diego / Public Utilities
Recycled Water Study
Draft Report

NO.	REFERENCE	COMMENT	CITY RESPONSE
		also much greater than from the Mission Gorge site. Provide a more realistic energy cost savings associated with the Padre Dam option versus the Harbor Drive option.	
PD-16	Table 4-1	Levy Treatment Plant demand is not addressed. Add Levy Treatment plant to the Table and discussion.	This table is no longer included and the language was clarified to discuss how early project sizing was completed.
PD-17	Figure 4-4	Annual Average line is not shown. Add	Added the annual average/max/ and min month to the figure.
PD-18	Figure 4-6	Annual Average line is not shown. Add	Added the annual average/max/ and min month to the figure.
PD-19	4.2.1.3	Third line of the first paragraph states that the Padre Dam WRF has an existing capacity of 2.3 mgd. The existing plant has a 2.0 mgd capacity. Revise to 2.0 mgd	Revised.
PD-20	4.2.1.3	Third paragraph. This paragraph describes the El Monte Valley project as an indirect potable reuse project but fails to mention that it is a ground water recharge project which is significantly different than a reservoir augmentation project from a regulatory perspective. Specify that the El Monte Project is an in direct potable reuse project that utilized ground water recharge.	Added.
PD-21	4.2.1.3	Discuss that Padre Dam is currently working with the Bureau of Reclamation in studying another location in the Santee Basin for Ground Water Recharge of highly treated recycled water. The capacity for IPR water at this site range from 1.5 mgd to 3 mgd. There may be other locations within the El Monte/Santee Basin where highly treated recycled water could be used to create new water. Add a discussion on additional locations in the Santee Basin for development of groundwater	An implementation step was added regarding this.

Appendix J
City of San Diego / Public Utilities
Recycled Water Study
Draft Report

NO.	REFERENCE	COMMENT	CITY RESPONSE
PD-22	4.2.2	recharge using highly treated recycled water. Conveyance systems were described for both the City of San Diego's and Otay's recycled water distribution systems but not for Padre Dam's system. Add a description of Padre Dam's recycled water conveyance system.	4.2.2 is regarding the City's system, which Otay connects to. Padre Dam's system is described in section 4.2.1.3. Please provide any specific edits desired.
PD-23	Figure 4-10	Annual Average line is not shown. Add the annual average flowrate to aid in the text discussion.	Added the annual average/max/ and min month to the figure.
PD-24	Table 4-2	The flowrate at Mission Gorge Diversion is not listed.	The projected flow rate at Mission Gorge has been added to the Table.
PD-25	Figure 4-12	There is no identifying site number for the East Mission Gorge Pump Station. Associated flow for this location should also be identified. Add a Site Number N13 at the East Mission Gorge Pump Station.	The East Mission Gorge flow was added as N9.
PD-26	Table 5-1	What about peak RW demands? What about utilizing seasonal storage as an mean to accommodate peak demands rather than building more treatment capacity? Add a discussion on how you planned on meeting peak demands and consideration for seasonal storage.	Peaking is discussed in Section 5.4.1. Seasonal storage was evaluated in the 2005 Study and was addressed in TM 5.
PD-27	Figure 5-2	Do not see areas served by the new Treatment Plant. More clearly identify areas served by new Treatment Plants.	This information was provided in TM 1. Please reference TM 1. Was not detailed in the final study since these were not pursued in the workshops.
PD-28	5.3.2	In discussing Future Wholesale Non-potable Recycled Water Opportunities, there was no discussion on how seasonal storage (if constructed) could allow service to this untapped demand without constructing new treatment capacity. Add discussion on how seasonal storage could aid in allowing the North City Plant meet additional recycled water demand for these future wholesale clients.	See PD-26.
PD-29	5.4.1	The fourth sentence of the first paragraph states "This generally means that the treatment plant capacity must be two times larger than the average demands resulting	See PD-26.

Appendix J
City of San Diego / Public Utilities
Recycled Water Study
Draft Report

NO.	REFERENCE	COMMENT	CITY RESPONSE
		in potentially underutilized capacity at the treatment plants.” This is not true if you implement seasonal storage. Add seasonal storage to the discussion to aid in reduction in treatment plant size.	
PD-30	6.1	Indirect Potable Reuse Summary, fourth paragraph, second to last sentence references the “El Monte Valley Project”. When referencing this project use the following title “El Monte Groundwater Recharge Project”. Use the title “El Monte Groundwater Recharge Project” in all references to this project to distinguish it from reservoir augmentation projects.	Revised.
PD-31	Table 6-1	Lake Jennings should be added, discuss with Helix Water District. Add Lake Jennings as a Surface Water Reservoir Candidate.	Added and implementation step regarding re-evaluating reservoirs again as regulations get finalized. This seems more appropriate an approach since the info listed served as a basis for the Study.
PD-32	Table 6-2 Surface Water Reservoir Candidates Not Advanced	For the Jennings reservoir, the first Key Consideration was that the reservoir is “Too small to meet anticipated regulatory requirements;....”. The relative small size would just reduce the capacity of this alternative compared to a larger reservoir, not prevent it from meeting regulatory requirements. Revise text	See PD-31
PD-33	Table 6-2 Surface Water Reservoir Candidates Not Advanced	For the Jennings reservoir, the last sentence under Key Considerations states “As the regulatory environment for indirect potable reuse evolves, these requirements may become feasible.” Lake Jennings will be subject to the same regulatory requirements as will San Vicente (size is not the issue). Revise text which discounts an IRP project at Lake Jennings from meeting regulatory requirements due to size.	See PD-31
PD-34	6.3.2	Ground Water Recharge Opportunities Considered. The first bulleted item is El Monte Valley. This should also include the Santee Basin. Revise the text for the first bulleted item to be “El Monte Valley/Santee Basin	Added an implementation step to update groundwater basin data as future studies progress.

Appendix J
City of San Diego / Public Utilities
Recycled Water Study
Draft Report

NO.	REFERENCE	COMMENT	CITY RESPONSE
PD-35	Table 6-3	Padre Dam is currently working with the Bureau of Reclamation in studying another location in the Santee Basin for Ground Water Recharge of highly treated recycled water. The capacity for IPR water at this site range from 1.5 mgd to 3 mgd. There may be other locations in the Santee Basin where highly treated recycled water could be used to create new water. Add a discussion on additional locations in the Santee Basin for development of groundwater recharge using highly treated recycled water.	See PD-34
PD-36	7.2	Third bulleted item discusses pumping wastewater and in the first sentence states “Most costly (and difficult to pump from and odor control perspective)”. Pumping wastewater is also most costly from and energy perspective. Add that pumping wastewater is also most costly from and energy standpoint.	Added.
PD-37	Figure 7-3	Instead of showing a Mission Gorge Plant near what appears to be the location of the Mission Gorge Pump Station, show the Plant to be at the site of the Padre Dam WRF. Revise location of the Mission Gorge Plant to be at the site of the Padre Dam WRF.	Location shown is generic until a siting implementation step is complete as outlined in 8.5.
PD-38	Table 7-2	North City/San Vicente Area Concept Summary – 2035. Where is the 7 mgd raw flow needed for the El Monte Valley Groundwater Recharge Project? Add the flow needed to supply water for the El Monte Valley Ground Water Recharge Project.	The table is now footnoted to clarify that the EMVGRP flows were accounted for.
PD-39	Figure 7-5	Show Padre Dam WRF location for general reference. Add location on Figure.	This figure shows facilities relevant to Theme A1. The Padre Dam plant has been added to Figure 7-9.
PD-40	Figure 7-6	Show Padre Dam WRF location for general reference. Add location on Figure.	This figure shows facilities relevant to Theme A2. The Padre Dam plant has been added to Figure 7-9.
PD-41	8.2	On page 8-5, “3” Sub-alternative states “Alternative “B3” is the same as Alternative “B2”, except that it included a	See PD-10

Appendix J
City of San Diego / Public Utilities
Recycled Water Study
Draft Report

NO.	REFERENCE	COMMENT	CITY RESPONSE
		<p>small plant in Mission Gorge to collect, treat and convey water to the San Vicente Reservoir. This adds a fourth plant, but it is the closest location to the San Vicente Reservoir.” Alternative B3 does not add a fourth plant but expands the Padre Dam WRF currently planned to serve local non-potable water demand plus the El Monte Groundwater Project. Remove text that says a fourth plant would need to be constructed (enlargement of the currently planned Padre Dam WRF from 10 mgd to 18.7 mgd would be needed).</p> <p>The current plan for Padre Dam WRF to accommodate non-potable and El Monte demands is to expand the existing 2.0 mgd plant to approximately 10 mgd. All alternatives in this study require that a minimum 10 mgd plant be constructed to accommodate these flows. In order to produce 6.8 mgd of IRP water to be sent to San Vicente (under alternative B3) an additional 8.7 mgd of plant influent capacity would be needed for a total of 18.7 mgd raw wastewater influent capacity.</p>	
PD-42	8.2.1	<p>El Monte Valley Groundwater Basin Project is an additional 5 mgd off load to Point Loma. El Monte Valley Groundwater Basin flow of 5 mgd is not shown on Reuse by Phase Graph, Reuse Per Plant Graph, Implementation Schedule Graph, Table showing Off Loads, and Table showing Capital and O&M Costs per Phase. Add El Monte Valley Groundwater Recharge Project to all Graphs and Tables in this Section.</p>	See PD-6
PD-43	8.2.2	<p>El Monte Valley Groundwater Basin Project is an additional 5 mgd off load to Point Loma. El Monte Valley Groundwater Basin flow of 5 mgd is not shown on Reuse by Phase Graph, Reuse Per Plant Graph, Implementation Schedule Graph, Table showing Off Loads, and Table showing Capital and O&M Costs per Phase. Add El Monte Valley Groundwater Recharge</p>	See PD-14

Appendix J
City of San Diego / Public Utilities
Recycled Water Study
Draft Report

NO.	REFERENCE	COMMENT	CITY RESPONSE
		Project to all Graphs and Tables in this Section.	
PD-44	8.2.3	El Monte Valley Groundwater Basin Project is an additional 7 mgd off load to Point Loma. El Monte Valley Groundwater Basin flow of 5 mgd is not shown on Reuse by Phase Graph, Reuse Per Plant Graph, Implementation Schedule Graph, Table showing Off Loads, and Table showing Capital and O&M Costs per Phase. By combining the offload that would be generated by the additional demands of El Monte, PDMWD's RW demands, PDMWD facility could be expanded to 18 to 20 MGD to achieve the economy of scale comparable to other options outlined in this study. Add El Monte Valley Groundwater Recharge Project to all Graphs and Tables in this Section.	See PD-14
PD-45	Table 8-10	The capital and O&M costs for the Mission Gorge Plant are too high and not consistent with current O&M costs for the Padre Dam Water Recycling Facility and the Black & Veatch Planning Study(s). Revise unit cost and extended amounts in the detailed cost estimate to be consistent with previous studies.	See PD-48
PD-46	Table 8-12	Alternative B3, fourth bullet under Key Infrastructure Siting and Complexity Considerations states "Mission Gorge Plant is relatively small due to smaller tributary wastewater flows limited and reduces Harbor Drive Plant economy of scale". The Padre Dam WRF (Mission Gorge Plant) is only small if you don't consider flows required for the El Monte Project. The Padre Dam WRF is planned to be approximately 18 mgd under this alternative, this should not be considered a small plant as it off loads 18 mgd from Point Loma. Revise text.	The statement assumes an independent plant. Implementation steps outlines in 8.5 can look at cost saving potential of joint plant operations and other benefits/impacts.
PD-47	Table 8-14	Salt Reduction Credit. Discussion does not explain how the \$100/acre foot credit would work. As the IPR water entering the San Vicente and Otay Reservoirs would benefit both the County Water Authority and the City of San Diego, would a credit be paid from these agencies	Agree. Added a note at the end of 8.5.5 under the cost sharing framework.

Appendix J
City of San Diego / Public Utilities
Recycled Water Study
Draft Report

NO.	REFERENCE	COMMENT	CITY RESPONSE
PD-48	Table 8-16	<p>to the wastewater side? The method of applying this credit needs to be practical or the benefit should not be claimed in the financial analysis. Explain how the Salt Credit would be implemented or remove it from the analysis.</p> <p>Column for Theme B3. The capital and O&M costs for the Mission Gorge Plant is too high and not consistent with current O&M costs for the Padre Dam Water Recycling Facility and the Black & Veatch Planning Study(s). Revise unit cost and extended amounts in the detailed cost estimate to be consistent with previous studies.</p>	<p>A broad costing protocol was used for this Study since it's a global master plan covering multiple plants, at multiple locations; and three different consulting firms provided cost data, which was reviewed by all stakeholders in previous workshops and meetings. Costs saving ideas specific to each option are welcomed and can be looked at as part of the implementation step for this area outlined in 8.5.</p>
PD-49	Detailed Cost Estimate Spreadsheet, Theme B3	<p>Padre Dam Expansion (Mission Gorge) Upgrades/Improvements for MBR uses a unit cost of \$7,400,528 per MGD and the Harbor Drive uses a unit cost of \$4,088,670 per MGD. Padre Dam's prior study showed that cost per MGD of MBR is closer to the cost associated with Harbor Drive Option. Revise cost to reflect lower capital cost for Theme B3.</p> <p>Similar high unit costs were used for the preliminary, primary treatment processes and AWTP. The detailed cost breakdown showed that the Padre Dam Option is twice the cost as the Harbor Drive Option. Studies completed by Padre Dam in the recent past reflected much lower cost per MGD to construct all facilities. Again, Padre Dam prior studies showed that capital costs for all aspect of capital improvements are in similar order magnitude as the Harbor Drive cost option. Revise cost assumption to reflect similar cost structure.</p> <p>O&M cost inclusive of AWTP for the Mission Gorge Facility showed an O&M cost of \$1.28M/MGD while the</p>	<p>See PD-48</p>

Appendix J
City of San Diego / Public Utilities
Recycled Water Study
Draft Report

NO.	REFERENCE	COMMENT	CITY RESPONSE
		<p>Harbor Drive Option has an O&M cost of \$0.69M/MGD. Currently, Padre Dam facility has an O&M cost structure on par with the PLWTP O&M cost on a per MGD treated basis even though it is much smaller plant and Padre Dam treats its wastewater to a higher level standard than the PLWTP. Additionally, PDMWD's facility is only 2 MGD compared to PLWTP rated 240 MGD facility. Therefore, additional justifications should be provided other than using a theoretical economy of scale curve. Revise O&M costs to reflect a more realistic estimate between options.</p>	
PD-50	Detailed Cost Estimate Spreadsheet, Theme B3	<p>Collection system improvements, under Pump Stations; EMGPS is \$20M for 10 mgd and the Harbor Drive Station is \$28M for 46 mgd. The EMGPS was originally designed with consideration for pumping this wastewater to the Padre Dam WRF site; therefore improvement costs for the EMGPS should be much lower per mgd than the Harbor Drive estimate. Either significantly reduce the EMGPS estimate or significantly increase the cost for the Harbor Drive improvement.</p>	<p>The unit costs for pumping are based on HP. $HP = \text{flow} \times \text{lift}$. Lift requirements are larger for the EMGPS. The static lift for the EMGPS is about 4.5 times greater than the HDPS, therefore greater HP is required which increases the cost. Cost is not based simply on flow. However, both locations have existing facilities that may be used to save costs, which can be assessed per the implementation steps in 8.5.</p>
POWAY-1		<p>Typos on pages 2-2, 4-10, 6-1, 7-7, 7-16, 8-3, 8-13. Correct typos.</p>	Corrected typos.
POWAY-2	Section 1.2 and 1.6	<p>Is a "natural water source reservoir" the same thing as a "surface water storage reservoir"? What is an example of a natural water source reservoir related to this project? This language conflicts and may mislead the reader as to where NPR water will be stored. Make language consistent.</p>	Revised.
POWAY-3	Section 1.1	<p>Will San Diego Coast Keeper and Surfrider accept a 100 mgd offloading at Point Loma and not take legal action at a later date to force elimination of any discharge to the ocean from Point Loma?</p>	This has not been discussed with Coastkeeper and Surfrider. Their intent is unknown.

Appendix J
City of San Diego / Public Utilities
Recycled Water Study
Draft Report

NO.	REFERENCE	COMMENT	CITY RESPONSE
POWAY-4	Section 1.2	Define “uninterruptible”. Does this term mean the same as uninterrupted water supplied by SDCWA? Is uninterrupted the same as “available”. Suggest including a definition in Section 1.6.	This term was used in Section 8.1.1. It refers to the fact that IPR water service is not affected by outside influences as imported water is. A definition was added to the glossary and section 1.6.
POWAY-5	Page 1-2, Figure 1-1	This map shows existing Metro facilities. Are all the yellow circles and squares part of the Metro System? Please provide answer.	The facilities have been removed from this figure and the title has changed.
POWAY-6		Has the EPA/Feds indicated that offloading Point Loma would definitely avoid an order to achieve secondary treatment? If yes, what is the minimum offloading that would be acceptable? Many of the alternatives have projected costs that exceed the estimate to upgrade Point Loma, why would a more costly alternative be pursued?	There have not been any discussions with the EPA as part of this Study and the EPA has not indicated that any amount of offloading would eliminate the requirement to convert to secondary or apply for a permit modification. This Study evaluated potential scenarios but the assumption used in this Study is that secondary treatment will be required, regardless of the offload. The potential to keep PLWTP at CEPT was discussed but was not the Study’s assumption. This will be a negotiating point at the permit update.
POWAY-7	Section 2.4 Page 2-5	Was the Recycled Water Pricing Study ever finished? Do we know the true cost of producing and distributing recycled water today?	The City will address pricing study questions separately.
POWAY-8		Find the number/letter schemes for the different options very confusing and hard to follow. Consider using descriptive names for the different alternatives instead of numbers.	Understood. ES-14 was created for this purpose. Will continue to consider improvements as it is finalized.
POWAY-9		Case-building on pros of the Harbor Drive facility are strong.	Agree. This is the location where the majority of the metro system wastewater collects so there are several benefits to placing a treatment facility here, as noted in the table.
POWAY-10		Request that additional methodology be included. In addition to using avoided costs as part of calculation to arrive at actual cost, provide	The cost comparison was revised and Appendix H was added to provide a clearer methodology and FAQ style summary. It also includes cost

Appendix J
City of San Diego / Public Utilities
Recycled Water Study
Draft Report

NO.	REFERENCE	COMMENT	CITY RESPONSE
		estimated actual cost of Point Loma upgrades to actual costs for alternatives including total project cost comparative and per acre-foot basis. Also include projected costs avoided with introduction of this new water source. Consider modifying methodology or showing a cost comparison both ways.	comparison tables and a comparative graphic.
POWAY-11		Concerned that the cost for the A1 through B3 alternatives is twice as expensive as upgrading PLWTP to secondary treatment. Need to better compare costs of alternatives A1-B3 to the cost of upgrading to secondary treatment at PLWTP.	While the cost is more, it generates a product that is worth something. That offsets buying imported water and end up with greater benefit. The implementation steps in 8.5 include cost sharing discussions.
POWAY-12	Section 4.2.1.1 Page 4-4	Shouldn't recycled water provide a viable alternative during times of drought and therefore increased usage would be allowed, even encouraged? If yes, then need to reconsider pricing structure and marketing of recycled water during drought. Figure 4-4 (text): "higher recycled water rates". Who is paying higher recycled water rates? Is this San Diego customers? Is this a unit cost increase? Describe higher recycled water rates, what the form of the increase is, and who is paying it.	Agree. This text has been deleted.
POWAY-13	Section 5.4.1 Page 5-6	Should peak management also be considered for recycled water usage? If yes, consider pricing incentives (e.g. off-peak electrical rate incentives to reduce electrical loads during peak usage periods) to shift use of recycled water to non-peak times. This might also apply to water usage given its relationship to energy costs.	This consideration has been added.

Appendix J
City of San Diego / Public Utilities
Recycled Water Study
Draft Report

NO.	REFERENCE	COMMENT	CITY RESPONSE
POWAY-14	Section 6.3.1 Page 6-3	<p>Figure 6-1 includes Loveland Reservoir but it is not on the list. Note to explain why Loveland Reservoir excluded.</p> <p>Figure 6-1 includes Barrett Lakes, list notes Barrett Reservoir, are they the same? Make title consistent.</p>	<p>Considered a part of Sweetwater. A note has been added to Table 6-2.</p> <p>Revised figure to label Barrett Reservoir.</p>
POWAY-15	Section 7.3 Page 7-3	How does SDCWA feel about using San Vicente Reservoir for storage capacity since they paid for the dam raise? Need to incorporate this into the study.	The SDCWA has been an active participant in the Study and the development of the Integrated Reuse Alternatives.
POWAY-16	Section 7.3.4 Page 7-6	Padre Dam proposed an alternative siting scheme which is not reference. How do these points about the strengths of Harbor Drive as a site compare to Padre Dam's proposed alternative siting? Need to incorporate this into the study.	The B3 option incorporates this issue. Whith the Mission Gorge Plant, the Harbor Drive Plant is 6.8 mgd smaller. See Table 7-2. PDMWD options to divert other flows to this location were screened out at the workshops.
POWAY-17	Section 7.4 Page 7-7	This section is confusing. Difficult to follow the points being made and connecting 7.3.5 to 7.4. Please evaluate the language and look for ways to clarify what you are trying to say.	Reworded the transition
POWAY-18	Section 7.5 Page 7-15	Options A and C meet only 50% of Otoy Water District non-potable demands between 2026 and 2040, how will the other 50% be met? Address the issue of meeting only 50% of projected demand.	Chapter 7 summarized preliminary work. All final options include 100% of Otoy's demands thru 2040.
POWAY-19	Section 8.1.1 Page 8-1	Love the idealism of a water reuse target as high as possible, but realistically may only be able to fund just what it takes. Need confirmation that 100 mgd guarantees that feds will accept that in lieu of Point Loma secondary upgrade. Or that something less	This will be a negotiating point at the next permit cycle.

Appendix J
City of San Diego / Public Utilities
Recycled Water Study
Draft Report

NO.	REFERENCE	COMMENT	CITY RESPONSE
POWAY-20	Section 8.1.4 Page 8-3	wouldn't be acceptable (e.g. 50 mgd). Table 8-1 is hard to understand and narrative doesn't help much. Improve explanation of Table 8-1.	This table is no longer relevant. Chapter 8 is revised and Appendix H includes a cost methodology summary.
POWAY-21	Section 8.2.1 Page 8-7	If the most a Point Loma upgrade could cost is \$1.053 billion, then considering alternatives costing more than \$1.5 billion doesn't make sense. Need more explanation of why alternatives that cost more than the Point Loma upgrade are recommended.	Appendix H attempts to provide a more clear comparison and cost methodology summary. Although the reuse program overall costs more, the value of the water produced makes it more beneficial.
POWAY-22	Section 8.4.1 Page 8-5	What is the necessity of alternative B3? Please better explain the benefits of that alternative. It's not clear to me why we're looking at this alternative and what the benefit of this option is.	The B3 option has been championed by the PDMWD. It does offer additional phasing of facilities which will be added to table 8-12.
POWAY-23	Section 8.4.1 Page 8-13	Don't understand references to "Unit Cost Basis." Clarify the language. The electricity cost of \$.12/ kW seems low. What is the basis for this number?	Revised heading to help clarify. Agree. The electric rate was used in the 2005 study and was discussed again. It was determined to be appropriate at the gross planning level.
POWAY-24	Section 8.4.3 Page 8-16	1) What is the cost for upgrading Point Loma to secondary treatment? Answer this question and clearly state it in this study. 2) "...Reliable, uninterruptible, untreated water supply..." – This is a unique benefit to the City of San Diego. How are they going to compensate the PAs for that benefit. Our wastewater becomes their commodity for this "uninterruptible" water supply. This will be a major policy discussion. Should be addressed	Clarified in revised Chapter 8 and Appendix H. See cost sharing discussion in 8.5

Appendix J
City of San Diego / Public Utilities
Recycled Water Study
Draft Report

NO.	REFERENCE	COMMENT	CITY RESPONSE
		in some way as part of this study. Raises the issues of revenue sharing, benefit sharing, etc. from not only the wastewater side but also the water side. A broader stakeholder discussion for both aspects would be valuable	
POWAY-25	Section 8.4.4 Page 8-17	Diagram text references “to the right” but there is not anything to the right. Just a typo that needs to be fixed.	Revised.
POWAY-26	Page 8-20	Several questions	?
POWAY-27	Pages 8-19 and 8-20	When I was looking at the chart, I was having a hard time remembering what “favorable” versus “unfavorable” meant. Provide a reference back to the page where that is explained more completely.	This has been added.
POWAY-28	Section 8.5 Page 8-21	This diagram (Figure 8-9) is hard to follow. Clarify the diagram.	Edits made to clarify including a timeline
POWAY-29	Section 8.5.2 Page 8-21	“Stakeholder advocacy at City and participating agencies” is a key implementation step. Therefore, City of San Diego should rethink approach on TM-8 (“not enough time to meet to provide an in-depth workshop for PAs”). If they want the PAs to be stakeholders and advocate, we need to understand and agree with the financing methodology. The most important concern for the PAs is the money! Plan a workshop with all PAs to review TM-8 and the financial analysis.	Agree that this is an important issue. Two workshops were held - one specifically on the model and one on the cost sharing framework. There will be important follow up meetings on this as stated in Section 8.5. TM 8 provided an estimate of the alternatives but detailed financing and cost and revenue sharing are details that stakeholders will work through outside of, and subsequent to this Study.
POWAY-30	Section 8.5.5 Page 8-23	Financial participation “Value Assessment” - Language is a little ambiguous. Provide clarification. This section (an	Noted. This will occur as part of the implementation. Additional edits have been made in Section 8.5.

Appendix J
City of San Diego / Public Utilities
Recycled Water Study
Draft Report

NO.	REFERENCE	COMMENT	CITY RESPONSE
POWAY-31	Section 8.5.7 Page 8-25	<p>San Diego’s policy perspective on this topic) is extremely important. Plan a workshop with all Pas to review TM-8 and the financial analysis. Workshop needs to include a dialogue on this topic and what San Diego’s thinking is.</p> <p>“In the event the Harbor Drive facility is not available, the level of indirect potable reuse could be significantly reduced and the cost of producing the same amount of treated water could significantly increase.” This study should include a more detailed analysis of what Harbor Drive’s capacity is in order to move forward.</p> <p>This sentence causes me concern. Seems like if this is such a pivotal question, then this study should include a more detailed analysis of what Harbor Drive’s capacity is. If there is not sufficient time before completing the report to go back to City Council, then the recommendations should include a list of next steps to further consider before moving forward (which would include this).</p>	<p>There is an implementation step in Section 8.5, which has been expanded. An additional implementation step regarding San Vicente was also added. There are other options, just at an added cost. In part, this section reiterates its critical water/wastewater importance to City decision makers who are considering multiple users for this site.</p>
POWAY-32	Section 8.5.8 Page 8-25	<p>“This is a critical decision that will have significant cost impacts.”</p> <p>Does this sentence mean that the current cost projections do not include the cost of the pipelines? Not much detail is provided on that, and those seem like an expensive piece of the puzzle and a really important component in deciding if/how to move forward. Address this in the study.</p>	<p>The cost of pipelines are included in the estimate. This is intended to indicate an early decision on Harbor Drive is needed to minimize piping costs. “Significant” has been removed.</p>

Appendix J
City of San Diego / Public Utilities
Recycled Water Study
Draft Report

NO.	REFERENCE	COMMENT	CITY RESPONSE
POWAY-33		The study doesn't discuss energy requirements to produce and pump the purified water. Were the energy requirements/cost factored into any aspect of the analysis? Address energy requirements and estimated costs for the required energy. Answer whether the projected energy costs were incorporated into M&O costs.	The adaptive model included energy costs specific to each type of water and every facility. A note was added to section 3.4 and appendix F, which included O&M costs for energy, labor and materials.
POWAY-34		The expected amount of new purified water that could be generated is approximately 70-75 MGD; how does that compare to the City of San Diego's daily potable water demands? What is the target date to off load 100 MGD from Point Loma?	The City's 2035 average annual water demands are projected to be 269 mgd. This does not include the demands of other agencies connected to the Water Authority aqueducts. The target date for this Study is 2035.
POWAY-35	ES-10	Non-Potable Recycled Water Opportunities paragraph, describes an analysis between more purple pipe and IPR. Is this analysis available? Provide analysis.	The analysis is described in section 5.4, second paragraph. It entailed a spreadsheet cost comparison between two options.
Surf-1	Pg 7-15, Table 7-4	Is there an error? Is the bottom left box supposed to have an X ?	The X has been removed. The A option did not include a South Bay IPR project.
Surf-2	Pg 8-22, 8.5.4	It is Surf rider's understanding that this report is not supposed to take a stance as to whether secondary improvements should be made at Point Loma or not. If so, perhaps this bullet point should be reworded.	This bullet has been revised so that no stance is taken on the issue of converting to secondary or not. This is a City/PA viewpoint.
Surf-3	Pg 8-24, 8.5.5.1	The following is a little unclear: "The 50 percent/50 percent split was discounted, but it was noted that this assumption assumed that an agreement would be met on the more detailed cost-share concepts. Orange County Water District and Orange County Sanitation District successfully used this approach for their Ground Water Recovery System project. Did Orange County use the 50 percent/50 percent split or a more detailed cost share concept? These sentences should be clarified a bit.	Orange County used a 50/50 split after they were unable to come to an agreement on a more detailed cost-sharing agreement. The text has been revised so that it is clearer.

Appendix J
City of San Diego / Public Utilities
Recycled Water Study
Draft Report

NO.	REFERENCE	COMMENT	CITY RESPONSE
Surf-4	Pg 8-25, 8.5.8	"If direct potable reuse becomes viable in the future, then the Harbor Drive Facility will likely convey indirect potable reuse water to the Advanced Water Treatment Plant, and a larger-diameter pipe would not be needed. Should the bolded word be direct potable?"	Edits included to clarify this point.
Surf-5	Pg B-4, Top paragraph	"Throughout this Study, the goal treatment capacity at the Point Loma Plant was held at 100mgd. However, according to Figure B-2, the influent flow to be received at the Point Loma Plant is 2035 is 61 mgd. This is because the treatment process selected for the Point Loma Plant was chosen for the ultimate required capacity of 200 mgd, which is projected to occur in 2050. The projected annual average daily flow to the Point Loma Plant in 2035 is 178mgd. Please clarify.	Appendix B has been revised and Figure B-2 has been replaced.
JP-1		It would be good to define Direct Potable Reuse in the Key terms section	The definition of direct potable reuse has been added to the list of key terms and is included in the glossary.
JP-2	Pg ES-6	The section: "Water Supply Considerations for the Water Reuse Target" ends with the sentence: "Indirect potable reuse can fulfill this need and, over time, do so at lower costs." You might add something like: "When and if the regulatory framework for Direct Potable Reuse matures that will help fulfill this need at a lower infrastructure and operating cost."	This was added to the sentence along with other comments from stakeholders.
JP-3	Pg ES-7	The table on ES-7 is important to understand, but I do not see how someone that has not been through this process can understand it. The table and the text leading to it need to be modified to make the concept and the table easier to understand	This table is no longer used. Reference simplified Chapter 8 language and Appendix H.
JP-4	Pg ES-16	ES-16 and other places talk of expanding NPR by 4	Noted. This is the approach taken for the City

Appendix J
City of San Diego / Public Utilities
Recycled Water Study
Draft Report

NO.	REFERENCE	COMMENT	CITY RESPONSE
		mgd. When a cost of service study is done, including the infrastructure cost of NPR it is not going to be as attractive as it is now with its subsidy from other uses. Do not expand the investment in NPR past what the City is already committed to. Additional investment in NPR is likely to be stranded when appropriate prices are assigned. Increase IPR by that amount instead.	related projects.
JP-5	Pgs ES-17 and ES-19	The time chart shows the North City and Harbor Drive plants taking 5 years each for construction. Will it really take that long?	This is a reasonable estimate at this time due to length and difficulty to construct pipelines.
JP-6	Pg ES-17 and 19	The term Tier 1, 2 and 3 are shown on the unit cost table, but I could not find that they have been introduced earlier in the document. It might be better to explain them in text before the figures as well as in the footnotes. Maybe the explanations on ES-22 and 23 should come before these figures.	Will look to improve readability.
JP-7	Pg ES-17 and 19	In the Unit Cost table the numbers are shown as \$, but aren't they actually \$ per acre foot?	Correct. The units have been added to the column heading.
JP-8	Pg ES-17 and 19	It was not easy to connect the footnotes with what they refer to in the figures. Number the footnotes instead of identifying them with non-specific dots	Moved notes directly under the tables they correspond to. Numbering not used due to space constraints.
JP-9	Pg ES-19	It would be helpful to have a numbered footnote with a brief explanation about why the B alternatives were so much cheaper than the A alternatives	This has been summarized in the first paragraph of ES-22.
JP-10	Pg ES-22	The explanation of Tier one on ES-22 is not clear. I think it is the avoided cost of not having to squeeze too much wastewater treatment onto the Point Loma plant site, but that is not clear from the text.	Text has been added to clarify this topic.

Appendix J
City of San Diego / Public Utilities
Recycled Water Study
Draft Report

NO.	REFERENCE	COMMENT	CITY RESPONSE
JP-11		The bullet point on ES-17 and 19 is clearer. I did not see where the sludge from the different sites will go. Should more information on that be included?	This document attempts to provide a high level overview of the study. Flow diagrams provided in TM 5 show where each stream is sent. In general, all solids are sent to PLWTP except the NCWRP solids, which are sent directly to MBC. There may also be a solids processing facility in the South Bay. The location of solids treatment does not effect this study or the outcomes because the costs associated with solids processing must be accounted for either way.
PA-1	1-2 & 4-8	This table is confusing as it shows both Metro & Muni facilities but is entitled "San Diego Metro System". Should be renamed to something like "San Diego Wastewater Service Area".	Changed the figure and the title.
PA-2	Appendix to be named 2-5	We have attached the draft of our white paper entitled " FLOW REDUCTIONS TO POINT LOMA WASTEWATER TREATMENT PLANT: OPTIONS OFFERED BY THE PARTICIPATING AGENCIES -- March 16, 2011 ". We formally request that this white paper be incorporated as Appendix G and included in the final report. We will be revising it somewhat and will send you the revised paper as soon as possible. This is an important request as we will recommend to the JPA Board not to accept the final report if this is not included as an appendix and referenced in the body of the report.	Paper added as Appendix I.
PA-3	7-8	Why are you not including the expansion of the Padre Dam facility to 20 MGD? This project could be started sooner and the Santee plant is much closer to San Vicente and would require a shorter pipeline. It would also benefit the City's municipal wastewater system because flow would be substantially reduced on the East Mission Gorge interceptor.	The B3 option provides an IPR facility in the Mission Gorge area that may or may not be coordinated with PDMWD plans per the implementation steps outline sin Section 8.5. Wastewater accounting includes an assumption for PDMWD non-potable reuse and the El Monte

Appendix J
City of San Diego / Public Utilities
Recycled Water Study
Draft Report

NO.	REFERENCE	COMMENT	CITY RESPONSE
PA-4	8-7	Why do you have South Bay Indirect Potable Reuse as Phase 4? You could immediately take 3 MGD off of Point Loma with the Diversion at Salt Creek for \$800,000. South Bay is an existing plant and it is being underutilized. Flow should be diverted to it to maximize its treatment capability and insure that the South Bay customers are being provided adequate recycled water. It is our understanding that Otay had to supplement with potable water in July because the plant did not have enough wastewater to produce the recycled water they needed.	Valley Groundwater Recharge project. B3 uses all remaining wastewater for a joint or separate project. Other projects diverting more wastewater to the PDMWD (such as via North City) were screened out in the workshops. The South Bay diversion is phased in parallel to the North City project as Phase I. South Bay IPR occurs later since it is prudent to permit it after San Vicente is proven. As previously responded to, any interim diversions will coordinated by the City and Otay outside of this Study.
PA-5	8-19	Table 8-16 is confusing and misleading. It needs to be expanded otherwise the average reader is going to think that all of these construction costs are only going to amount to \$300 per acre foot. It should also be shown as costs per gallon as well as cost per acre-foot because many of the readers of this report will be wastewater customers who think in cost per gallon not cost per acre-foot. The details that roll up into these numbers at each level plus the assumptions made per line item need to be included in an appendices and reference for the reader to easily find. Same comment for Table 8-17	The cost discussion prior has been modified to clarify gross costs and net costs. A new cost methodology FAQ has been developed and is provided in Appendix H. \$/gallon totals are now shown in the tables. The cost sheets are included as appendix F.
PA-6	8-23	Reword this from "...that there will be sizable wastewater..." ...to "there might be..." under Concept 1.	Changed

Appendix J
City of San Diego / Public Utilities
Recycled Water Study
Draft Report

NO.	REFERENCE	COMMENT	CITY RESPONSE
PA-7	General	The Pas have submitted comments to each one of the TM's but have never seen the comment sheets back with the action taken to address these comments in the report.	The comment sheets along with responses to each comment have been included as attachments to each Final TM.
PA-8	7-3	What is the current arrangement with the CWA on using San Vicente for storage? Can San Vicente hold all of the proposed IPR water during the winter months during major rain events? How much water does San Vicente currently and normally hold during the summer and winter months. Put a table in showing what the average summer and winter levels are, the proposed addition of IPR water and the balance still available as a failsafe so that IPR water is not lost during major rain events. Same thing should be done for Otay.	These detailed operating plans are part of the implementation and edits have been made in this section (8.5) to clarify this point. IPR flows would offset imported water entering these reservoirs. IPR sizing accounted for reservoir capacity per chapter 6 and TM 5.
PA-9	2-5	You reference the recycled water pricing study on this page but we have not seen the most recent draft. The price of recycled water is important from many perspectives. It needs to recover some costs but it also should not be so high as to discourage expansion of recycled water use. This study has not been provided to the stakeholders to determine if the assumptions are accurate or flawed. If the study is being indicated as relevant to the Recycled Water Study we are concerned as it has not been vetted by the stakeholders. This should be vetted by the stakeholders prior to the finalization of the report.	Reference has been removed.
PA-10		Attached is the PDF of the report with sticky notes on the following pages: 1-3, 2-1, 2-2, 2-5, 7-2, 8-6 and 8-18.	1-3) Heading changed to Metro JPA Members. 2-1) Revised per recommended edits. 2-2) MER discussion added to Appendix B. 2-5) The City will address Pricing Study questions

Appendix J
City of San Diego / Public Utilities
Recycled Water Study
Draft Report

NO.	REFERENCE	COMMENT	CITY RESPONSE
			<p>separately 2-5) Recommended edits to text incorporated. 7-2) Flow is the correct term – no change. 8-16) The offset cost evaluation is based on the September 2011 Draft WMP. This WMP does include the wet weather storage facilities. 8-18) Text was added to the paragraph above the figure to indicate that MWD costs may increase if less water is purchased.</p>
PA-11	Page ES-1	Under background please include more information regarding the waiver and Cooperative Agreement, etc.	The Cooperative Agreement is included in the appendices.
PA-12	Page ES-1	<p>Please reword the second sentence in the second paragraph for water supply is obtained from the Bay-Delta and the Colorado River and conveyed via the California Aqueduct and the Colorado River Aqueduct.</p> <p>Please revise the second to last sentence as well under the same premise.</p>	These two sentences have been revised.
PA-13	Page ES-1	It should be clearly stated that the environmental community's goal is to reduce solids loading into the ocean by means of going to the secondary treatment level at Point Loma WWTP. Reducing solids loading will occur if reuse of recycled water becomes a reality. The PA's are concerned not only with exposure to substantially higher capital costs and O&M costs and increases to these costs associated with going to the secondary level at the Point Loma WWTP at any capacity level.	See response to this comment on previous TMs.
PA-14	Page ES-1	The City of San Diego and the Recycled Water Study (Study) team continues to state that "the City's responsibility per the Cooperative Agreement is to execute the Study", clearly implying that the City's only intent is to complete the Study and not create additional recycled water local supplies for both non potable and	See response to this comment on previous TMs.

Appendix J
City of San Diego / Public Utilities
Recycled Water Study
Draft Report

NO.	REFERENCE	COMMENT	CITY RESPONSE
		indirect potable reuses. The “Goal” of the study as stated is “Maximization of reuse.” Completing the Study does nothing toward developing actual reuse projects nor addresses the Point Loma WWTP potential requirement to change to secondary treatment. Please state the City’s intent regarding Point Loma and local water supply development.	
PA-15	Page ES-2	Add “Wholesale Connection” as key term. It is used throughout this report but documents referenced in this report make no distinctions between a typical customer meter and a wholesale customer like Otay WD that has their own customer base.	The term “Wholesale Customer” has been added to the glossary.
PA-16	Page ES-5	The Study process overview description is incomplete. Please document how the PA’s comments were addressed for each TM. Did the City address all of the PA’s comments on the TM’s? The work session timeline appears to document more status update meetings than was actually held. Who attended meetings 9 and 10?	The comment/response form for each TM was included as an appendix to the Final TMs. This form includes all the PA comments as well as responses to these comments. PA representatives attended both status update meetings 9 and 10.
PA-17	Page ES-6	Revise to say indirect potable reuse can fulfill this need and, over time, do so at lower costs if costs savings from the Point Loma WWTP are considered.	Revised.
PA-18	Page ES-7	What was the primary driver that caused the cost to increase at 100 mgd was it the cost of more expensive treatment processes or that the land area was limited at the Point Loma site.? List the cost factors for each.	This section has been replaced. See Appendix H for full discussion.
PA-19	Page ES-7	Identify the source of the \$1.053 billion estimate. Is this the low end of the estimate or the high end?	This section has been replaced. See Appendix H for full discussion.
PA-20	Page ES-8	Revise text as three wholesale purchasers of recycled water for the City are located.	Revised.
PA-21	Page ES-8	List the following as a key component in the table. The Otay WD in May of 2007 completed the construction of recycled water transmission main, reservoir, and	Added a summary of this here, as well as in chapter 4.

Appendix J
City of San Diego / Public Utilities
Recycled Water Study
Draft Report

NO.	REFERENCE	COMMENT	CITY RESPONSE
		<p>pump station to link the existing Otay WD recycled water system to the South Bay Plant. The system link allowed for access to the South Bay Plant recycled water supply. Prior to that the Otay WD was supplementing the recycled water supplies from the RWCWRF with imported treated water supplied by the SDCWA. The Otay WD 100% funded the approximately \$43 million dollar supply link. Please add this information to the text.</p>	
PA-22	Page ES-9	On the map add the above listed Otay WD transmission main.	The report does not include detailed layouts for the OWD and PDMWD systems as it drew the limits as to the details shown. The Figure is primarily about the regional treatment plants, and both OWD and PDMWD's are shown.
PA-23	Page ES-10	The summary must be written to maximize the use of non-potable water first before it is used for IPR.	This Study, like the 2005 Study, concluded that IPR should be pursued in lieu of pursuing additional NPR within the City, with NPR continuing for Otay and PDMWD. This is discussed in NPR paragraph on ES-10.
PA-24	Page ES-10	The non-potable summary statement that "cost to dual pipe an existing community...higher than the IPR approaches for new areas" doesn't make sense.	This Study, along with the 2005 Study, and several others have concluded that the cost to dual plumb an existing community for NPR can be greater than IPR.
PA-25	Page ES-10	Dual plumbing of all new developments must continue, not just on maximizing the existing system where most economical.	The direction from the work sessions and meetings focused on IPR over this. This will be an agency by agency policy determination.
PA-26	Page ES-10	Revise text to say that the non-potable recycled water demands carried forward can be summarized as the existing demands, planned demands, and future demands (which includes 3 mgd for expanded service from the South Bay Plant occurring between 2026 and 2040 totaling 9 mgd annual average total demand for the Otay WD).	This ES is for a high level overview. The details of the demands have been included within the report. An individual total just for Otay in the Executive Summary creates equity issues for other wholesale customers. Otay demands are clearly listed in Table 5-3.
PA-27	Page ES-11	The timeline for wastewater flow diversions to the South Bay Plant to meet Otay WD non-potable recycled water	Interim flow diversions will not be discussed in this

Appendix J
City of San Diego / Public Utilities
Recycled Water Study
Draft Report

NO.	REFERENCE	COMMENT	CITY RESPONSE
		monthly supply needs need to line up with the monthly supply requirements and demand levels previously provided by Otay WD staff to the Study team. Nearer term wastewater diversions to the South Bay Plant need to be accomplished in order to achieve the non-potable recycled water demand levels within the Otay WD jurisdiction on a monthly basis. List in the table the short term Salt Creek Inceptor diversion to the South Bay Plant. This needs to be addressed and discussed within the text.	study as previously noted. Otay and the City have discussed the funding of the Salt Creek diversion and those discussions should be held outside of this study.
PA-28	Page ES-13	For the Otay WD include in the table the total ultimate build out irrigation demand number of about 9.0 mgd annual average which is about 10,000 acre feet per year. The peak month demand would be about 18 mgd for the Otay WD.	See PA-26. As a point of clarification, our understanding from past correspondence is that the 18 mgd is a peak day total not a peak month total. The reuse study uses peak month totals based on OWD provided data. There is excess capacity beyond peak month for peak day demands as noted in Chapter 5 and previous response to comments.
PA-29	Page ES-13	The IPR Project Advanced table should include the potential impact of existing and future potable water demands at, for example the Otay WTP, relative to the reservoir augmentation quantity potential upon detention time and customer consumption percentage of non potable reuse water. Since the annual demand at Otay Lakes in 20 mgd and the table showing augmentation at up 22 mgd the percentage of consumption the recycled water would indeed be very high.	The demand at the OWTP is projected to be 33 mgd as noted. The table shows the potential flows based on hydraulic retention time regulatory limits as described in the footnote. Unclear what edit is needed here.
PA-30	Page ES-14	Identify elements from South Bay area concepts and elements from other agencies.	Text added to clarify. Elements from the South Bay area and other agencies are provided in the facing table.
PA-31	Page ES-17	Please add a sentence or two to state that the costs shown in the following tables do not include the O&M and any other costs for treatment at the Otay WTP or the Alvarado WPT to produce treated water	A footnote has been added.

Appendix J
City of San Diego / Public Utilities
Recycled Water Study
Draft Report

NO.	REFERENCE	COMMENT	CITY RESPONSE
PA-32	Page ES-18	Reuse by Phase; Harbor Drive IPR 52.8 MGD missing in graph	Harbor Drive IPR 52.8 is shown in the bar chart on ES-18. There is one less step in B1/B2 which may be the confusion here.
PA-33	Page ES-22	Please include two more tables similar to table 8-15 separating the South Bay System from the North City System. That is one table for South Bay and one table for North City.	The Integrated Reuse Alternatives include a combination of projects that were developed in the Area Concepts section. The costs for each of the options – including C2 – are included in the appendices.
PA-34	Page ES-23	Include the South Bay Plant expansion, pump station, and transmission main to Otay Lakes in the list of the table.	As the C2 option is common to all alternatives, it is not necessary to include elements of that project in a comparative summary table.
PA-35	Page ES-25	Where is the Otay WD South Bay Plant offto of 9 mgd? Add to the list and pie chart.	This is included within the South Bay Plant flows and the SV8 flows. The South Bay NPR of 9 mgd can be found in table 5-3.
PA-36	Page ES-26	Where is the box for South Bay NPR water for Otay WD? Please add.	South Bay non-potable reuse is included in the first box titled South Bay non-potable reuse.
PA-37	Page ES-26	Implementation for the North City and South Bay should be parallel, not sequential to be consistent with the earlier schedules. Re-label North City initial IPR as <i>Demonstration Project</i> and add another box for North City IPR parallel to South Bay IPR	The South Bay box has been adjusted.
PA-38	Page ES-26	It should be addressed within the Study that the CWA and its member agencies are major stakeholders in the concept of IPR within particularly the San Vicente Reservoir. The CWA and its member agencies should be approached to discuss many related topics some of which include public perception, public outreach, IPR water ownership, who pays for what, etc. The outcome of the CWA and its member agency stakeholder thoughts, approaches, positions, etc. should be included within the Study.	The CWA has been an active participant in each step of the study.
PA-39	Page ES-27	Tech/Other; Include the South Bay Plant expansion, pump station,	Added.

Appendix J
City of San Diego / Public Utilities
Recycled Water Study
Draft Report

NO.	REFERENCE	COMMENT	CITY RESPONSE
PA-40	Page ES-27	and transmission main to Otay Lakes in the list. Include discussion on benefit sharing on water produced and other benefits.	This is included as an implementation step, Section 8.5
PA-41	Page ES-27	Frame work concept descriptions are confusing, i.e. Water Expense versus Wastewater Expenses and 50-50% Split. How will Prop 218 fit into these discussions?	Cost sharing discussions are an implementation step as outlined in Section 8.5. Discussion of prop 218 may be included in this future implementation step, specifically the steps now listed in 8.5.5
PA-42	Page ES-27	The Study is deemed incomplete for it did not address and evaluate all viable recycled water supplies and reuse opportunities or options that the wholesale recycled water users and the Participating Agencies (PA's) are interested in accomplishing that were identified by the PA's in the White Paper. These opportunities are clearly within the intended Study purpose and approach. Given the fact that the Study team has not addressed these opportunities the Study appears to be incomplete. The Study team appears to have purposely not included those opportunities that were identified early enough during the Study by the PA's to be dealt with by the Study team. It is clear that the City of San Diego has an agenda to direct essentially only its attention within the Study to indirect potable reuse primarily targeted at San Vicente Reservoir to the exclusion of existing viable non-potable reuses of the wholesale recycled water agencies and other PA's.	See response to PA-11 on TM 8.
PA-43	General Comment	As discussed at previous Metro TAC meetings the vision of the study should be to incorporate the concept and strategy that the total solids loading into the Pacific Ocean from the Point Loma WWTP at the advanced primary level will be substantially reduced by increasing the reuse of recycled water at other local treatment facilities. The strategy is that by agreement with EPA to permit the Point Loma WWTP at the advanced primary level at a reduced total flow than it is now such that the	See TM 8, PA-12 response.

Appendix J
City of San Diego / Public Utilities
Recycled Water Study
Draft Report

NO.	REFERENCE	COMMENT	CITY RESPONSE
PA-44	General Comment	Please provide very concise statements within the Study report that IPR owners and operators are to pay the NPR water rate for the supply of NPR water to be run through the IPR process and that the PA's expect to share in the revenues generated beyond the O&M expenses from any sales of NPR and IPR water, per the existing contracts.	This is an implementation step per section 8.5.
PA-45	General Comment	It looks as though the collected unit cost data used to develop infrastructure and operational costing include the revenue side of the equation. Who gets or owns the IPR water after all is said and done and how much will they pay for the water? How do the PA's get reimbursed for their costs? Where is the nexus per AB1600 between cost and benefit for sewer service versus the water customers and how will this be addressed? Both analyses need to be separately for the South Bay and North City Systems/Plants.	This is an implementation step per section 8.5.
PA-46	General Comment	It should be addressed within the Study that the CWA and its member agencies are major stakeholders in the concept of IPR within particularly the San Vicente Reservoir. The CWA and its member agencies should be approached to discuss many related topics some of which include public perception, public outreach, IPR	The SDCWA had had a representative as a stakeholder that has participated throughout the Study, as listed in ES-4 and page 1-3.

Appendix J
City of San Diego / Public Utilities
Recycled Water Study
Draft Report

NO.	REFERENCE	COMMENT	CITY RESPONSE
PA-47	General Comment	<p>water ownership, who pays for what, who benefits from the new water supply, etc. The outcome of the CWA and its member agency stakeholder thoughts, approaches, positions, etc. should be included within the Study.</p> <p>Why would not the regional wastewater system users including the City and the PA's consider funding any new local water supply development project such as the El Monte Project and Padre Dam Concept totaling 20 mgd, or others using recycled water just as those being considered as opportunities as defined in the Study? They should be! There is no difference to benefits to the region.</p>	<p>Working together to find the best solutions is the intent of the Study. The implementation steps include further analyses to detail the alternatives to find additional benefits or reduced costs. Any upstream improvements such as the PDMWD option would not alter the alternatives – it would just make Harbor Drive smaller (which is what B3 does). As the project proceeds, the City and PAs should work together to find the best benefits at the least cost.</p>
TR-1	ES-General	<p>Executive Summary does not include a summary of conclusions/recommendations to clearly guide decision makers on where to go next.</p> <p>Before Key terms add a conclusion/recommendations section. You really need to sell the concepts/recommended approach up front in the document. Some ideas things that could be included as recommendations:</p> <ol style="list-style-type: none"> 1. Develop recycled water supplies to offset requirements for upgrades to the Point Loma Plan. 2. When considering all benefits, it is cost effective to proceed with development of 80 to 100 MGD of recycled water supplies 3. To meet recycled water supply goals, it will be necessary to transition from development of non-potable supplies to development of potable reuse using purified water. 	<p>A results and conclusion page is now included at the start. The next steps were not moved since it was viewed as being out of context that early in the summary.</p>

Appendix J
City of San Diego / Public Utilities
Recycled Water Study
Draft Report

NO.	REFERENCE	COMMENT	CITY RESPONSE
		Etc.... Move next steps, pg ES-25 to follow summary recommendations. Right now the reader will have to go through all of the technical information before they get to what do we do next.	
TR-2	ES-1	This section does not mention anything about economic well being. Discuss the need for a reliable and drought proof water supply to support economic development in San Diego County.	Economic well being was incorporated into the conclusions section (Page ES-1) under reliability.
TR-3	ES-2, Key Terms	Change definition of advanced purified water. Propose new definition: Purified or advanced purified water is water of wastewater origin that undergoes advanced treatment to achieve a quality of water that is suitable for augmentation of a raw drinking water source. Advanced treated water is currently used for indirect potable reuse projects.	The key terms in the report has been revised based on multiple comments. In addition, a note has been added to the heading that notes that some definitions may differ from legislative definitions with a note referring to the California Water Code.
TR-4	ES-2, Key Terms	Indirect potable reuse can be done using tertiary treated water for groundwater recharge and does not require advanced treated water. Propose new definition: Indirect potable reuse means the planned use of recycled water for replenishment of a groundwater basin or an aquifer that has been designated as a source of water supply for a public water system, or the planned placement of recycled water into a surface water reservoir used as a source of domestic drinking water supply (WC 13561)	The key terms in the report has been revised based on multiple comments. In addition, a note has been added to the heading that notes that some definitions may differ from legislative definitions with a note referring to the California Water Code.
TR-5	ES-2, Key terms	Untreated Water, definition implies that all untreated water must be treated before use as potable supply. Many groundwater supplies are used without further treatment. Propose new definition: Raw Surface Water: Raw surface water is water that is collected and stored in local surface water reservoirs prior to treatment at a potable water treatment plant. Raw surface water examples include Colorado River water, water from the	The key terms in the report has been revised based on multiple comments. In addition, a note has been added to the heading that notes that some definitions may differ from legislative definitions with a note referring to the California Water Code.

Appendix J
City of San Diego / Public Utilities
Recycled Water Study
Draft Report

NO.	REFERENCE	COMMENT	CITY RESPONSE
TR-6	ES-2, Key terms	California Bay-Delta and runoff from local rainfall Potable (drinking water) implies that all sources must be treated. Also it references only Federal standards...California standards may be more stringent. Propose modified definition: Potable water is water that meets the USEPA and California Safe Drinking Water Act standards. Residents and businesses receive potable water at their water meter connection and its use is unrestricted.	The key terms in the report has been revised based on multiple comments. In addition, a note has been added to the heading that notes that some definitions may differ from legislative definitions with a note referring to the California Water Code.
TR-7	ES-6, Water Supply Considerations	A visual showing costs of producing recycled water and increasing costs imported water supply would be compelling. Add graph showing this information	This was the intent of the graphic on page ES-23, recognizing this comes much further back. Will assess ability to include a simplified version earlier.
TR-8	ES-8, Existing recycled water systems	This refers to recycled retailers as wholesalers. Change last sentence of paragraph: In addition to serving customers within the city of San Diego, recycled water is deliver to three retail agencies outside the city: city of Poway and Olivenhain Municipal Water District (Northern Service Area), and Otay Water District (Southern Service Area)	Revised similar.

BB=Bruce Bell
PA=Participating Agency
Surf=Julia Chun

CV=Chula Vista
JP=Jim Peugh
PD=Padre Dam

**City of San Diego
Recycled Water Study
Final Draft Report Comment/Response Form**

NO.	REFERENCE	COMMENT	ACTION
OTAY			
Otay 1		Otay has repeatedly made the point that this report needs to be less IPR centric and concentrate first on NPR. The City's response to Otay's comments is that <i>...IPR water use, the most expensive option, is unlimited and NPR is limited to specific non-potable reuse opportunities. Water used for irrigation is not recovered. IPR is recovered and used again...</i> If 50% of IPR water will be used outside the home for landscaping, how will this water will used again?	The study focused equally on NPR and IPR, with TM 1 and 2 dedicated to NPR. The Study includes existing and planned NPR flows, and additional NPR flows for Otay's. Other Stakeholders felt strongly regarding IPR, so the Study balances these perspectives since IPR offloads Point Loma during the critical wet weather period. Regarding this section, we have clarified that "indoor" uses are recovered.
Otay 2	Section 2.3.4	The 2010 Recycled Water Master Plan (RWMP) will identify NPR projects which are key to the Recycled Water Study, The PAs should be provided a copy to make sure this report includes the projected demands recommended in the RWMP are included into this report. These results of these reports need to be integrated to make the most cost efficient decisions.	Both the Recycled Water Study and the Recycled Water Master Plan were based on the demands shown in TM 1 and 2 of the recycled water study (which includes demand data from the PAs). The RWMP outlines a program that could occur if IPR is not pursued. The stakeholder representatives elected to pursue the NPR/IPR plan shown in the Recycled Water Study. They agreed to provide additional NPR to Otay as requested, but also felt that based on the analysis conducted under the recycled water study an IPR strategy would be more effective in offloading the Point Loma Plant.
Otay 3	Section 2.3.4	The City has stated that if the demonstration project does not show IPR being feasible, the City would revisit a more NPR centric plan. An NPR centric plan is key to providing the most cost effective use of this resource. This can be done with this report and is clearly within the scope of work. If IPR doesn't work for economic or issues related to CDPH, do we need a backup plan?	See Otay 1 regarding NPR vs. IPR, The recycled water master plan provides the backup plan.
Otay 4	Section 2.3.4	Response to previous comments stated <i>"it is recognized OWD is a strong proponent of NPR and the plan includes Otay's desired NPR flows"</i> misses the point being made. Approx. 50% or more of the water used in	NPR or IPR can be more economical depending on the situation. For South Bay, it was economical and the Study includes Otay's demands. In concert with that, the Study found integrating IPR elements also have

**City of San Diego
Recycled Water Study
Final Draft Report Comment/Response Form**

NO.	REFERENCE	COMMENT	ACTION
		San Diego is used for landscaping. The cost to develop IPR water is too expensive when a cheaper alternative, NPR is available. That is why we need to do conservation first, NPR second and IPR last.	important benefits as it offloads Point Loma and South Bay during the critical wet weather period where NPR does not. This study provides the desired flow to Otay, offloads Point Loma and South Bay, and produces high quality, reliable and affordable water. We hope Otay can appreciate there are multiple stakeholders on this Study, and Otay is getting its desired NPR flows.
Otay 5	Section 4.2	What are the conclusions of the 2010 Recycled Water Master Plan? A summary should be included.	The City's recycled water master plan is a public document and will be available on the City's website.
Otay 6	Section 4.2.2	Correct the length of the conveyance system to 0.5 mile of pipe. The City doesn't have 3.12 miles of conveyance in the southern service area.	The City has verified that 3.12 miles of Recycled Water pipeline is correct.
Otay 7	Section 4.2.2	The City of San Diego currently has essentially no recycled water transmission or distribution system in the South Bay except for their approximately 3,000 feet of 30 inch recycled main which was constructed as a part of the SBWRP project. To characterize this very limited pipeline as a recycled water system is clearly overstating the facts.	See Otay 6.
Otay 8	Fig. 4-9	Label bottom data set below axis "Maximum Month"	Added
Otay 9	Fig 4-12	Show PLWTP and Harbor Drive Diversion at PS 2 to match previous figure 4-11.	Revised
Otay 10	Section 4.4.6 and Fig. 4=13	Clearly state the volume of water through the whole treatment cycle, not just as it leaves the wastewater treatment plant. The figure is misleading and is not complete. The water loss must be shown to include evaporation (5-10%), or loss during a storm event (0 to 100%). This section and this figure understate the quantity of water that will be available for potable use. This also has a cost impact as the true volume of water available for distribution as potable water will be less than identified in this report.	Local losses are the same whether this is IPR or imported water. In the bigger picture, we lose less water from locally produced IPR projects than imported water that travels long distances with greater evaporation.
Otay 11	Section 6.2	Why limit expansion of NPR?	The City did not limit the expansion of NPR. An NPR and IPR strategy was chosen through extensive

**City of San Diego
Recycled Water Study
Final Draft Report Comment/Response Form**

NO.	REFERENCE	COMMENT	ACTION
			analysis, workshops, and discussion with the Stakeholders group. See Otay 1.
Otay 12	Section 7.2 Pg. 7-2	Bullet points at bottom of the page; Comparing IRP as the most ideal compared to non-potable because you are wasting 15% through the RO process actually makes the case that non-potable is more valuable than IRP. You get 15% more NPR to reuse. Saying IPR is 15% more efficient because you have 15% less IPR water to pump (because it is lost in production) is weak.	This section simply summarizes why it was better to treat and pump IPR water versus pumping wastewater and then treating to IPR at the destination. It is not an assessment of NPR vs. IPR. See Otay 4.
Otay 13	Section 8.2.1 Table 8-4	These tables are confusing. If 99 MGD is being offloaded, what is the net new water? If 5% loss as sludge, 8% loss through tertiary, plus 15% loss for advance treatment, isn't the net new water a little over 70 MGD? Same question for the cost per acre-feet, isn't the cost much larger since the net volume is less? What about the treatment cost for the loss during treatment. Where is the cost for this treatment accounted for? Isn't a larger volume greater than 100 MGD needed to actually offload 100 MGD from PLWTP?	The treatment plants are sized and costed based on influent flows. The offload is accounted for as effluent flows. Therefore, the Study properly accounts for the input and output volumes, their costs and their benefits. The offload north of Interstate 8 is the output to San Vicente. The offload south of Interstate 8 is the diversion via the Spring Valley No. 8 connection. The two page summaries for each alternative show the water produced and the Point Loma offload.
Otay 14	Section 8.5.4	Change Finalize to develop a cost sharing framework. You can't finalize a cost sharing framework that hasn't been disclosed. This needs to be consistent with Section 8.5.7 that states " <i>discussions between the City and PAs could become the frame work</i> ". Include Prop 218 review since any discussion on cost sharing must consider this state law.	Revised to "Develop and finalize....". Prop 218 would be included under review of legal issues already stated in Section 8.5.4.
Otay 15	Section 8.5.5	Change Finalize to develop a cost sharing framework. You can't finalize a cost sharing framework that hasn't been disclosed.	Implementation step rephrased
Otay 16		More time is needed to do a thorough review.	
POWAY			

**City of San Diego
Recycled Water Study
Final Draft Report Comment/Response Form**

NO.	REFERENCE	COMMENT	ACTION
Poway 1		Agree with many aspects of the study. Appreciate its thoroughness.	Noted
Poway 2		Supportive of the AWP/reuse concept, but it is still very hard to understand the true cost of the project options to the participating agencies.	A clarifying graphic was presented at the report review session. This will be incorporated into the Cost Methodology. A detailed cost split between Metro agencies was not the intent of the Study; however, this is included as a recommended implementation step to occur once a cost sharing approach is agreed to. The Study develops a comparative analysis using the difference between the reuse approach and the wastewater approach as the potential contribution that Metro (City and PA) could make. With this approach, it attempts to keep the Metro costs the same regardless of whether a reuse centric or wastewater centric approach is taken. The study then determines what benefits are derived by the reuse route as opposed to the wastewater centric approach. Since there are clear benefits to the reuse approach (not just water at a reasonable cost), the Study recommends proceeding with the implementation steps and working out a cost sharing agreement between these parties.
Poway 3		We understand the importance of knowing the end cost of the water per acre-foot to compare against the cost of purchasing imported water, but that's really only meaningful to the City of San Diego, since they're the only agency able to look at this is a replacement for water supply.	See Poway 2.
Poway 4		What is the cost for the different options going to be for participating agencies? At what point in the treatment/purification process does the participating agencies' financial participation begin (compared to what we pay for now) and end (when it's considered a San Diego water system cost)?	See Poway 2
Poway 5		Recognizing the long-term value of this new water supply and the long-range implementation horizon to	See Poway 2

**City of San Diego
Recycled Water Study
Final Draft Report Comment/Response Form**

NO.	REFERENCE	COMMENT	ACTION
		bring this project to complete fruition, how would the costs be spread out between the City of San Diego/participating agencies/water customers?	
Poway 6		Is there any possibility to sell this advanced purified water supply to SDCWA or other local water districts?	The SDCWA could participate beyond LRP funding. Even indirectly, they will receive a portion of the water when then use San Vicente. There is an implementation step involving policy decisions on SDCWA. An additional implementation step has been added to address financial partnership and broader policy issues.
Poway 7		What about bringing SDCWA in as a financial partner so they can add this water to their water supply portfolio? Would result in cost-sharing for City of San Diego and enhanced water reliability for the region.	See Poway 6
Poway 8		How can other water districts benefit from SBX7-7 value of creating recycled water? Seems like participating agencies (or rather, applicable water agencies) should be able to get some type of SBX7-7 credit for this project since our wastewater is being used to create the recycled water and we are helping to pay for the project?	A new implementation step was added to address.
Poway 9		Location near Qualcomm Stadium – How would this location be impacted by potential redevelopment of the Qualcomm Stadium site?	This site is close to the Stadium site, but it is not the actual stadium site. It is a vacant site south of the San Diego River, owned by the City.
Poway 10		Salt Credit – Is this real money? Does some agency actually give a financial credit for this? Or, is this just the estimated avoided cost because the water is less salty? If the latter, where is San Diego expecting to realize this cost savings? At the treatment plant? In the pipelines? Very unclear.	The salt credit is similar to the Point Loma offload benefit. By doing reuse, you avoid a cost somewhere else in the system. The credit of this would be from the downstream water system (City and SDCWA agencies served by San Vicente) and wastewater system (Metro). The crediting of this money would need to be worked out. This has been added to the implementation checklist.
Poway 11		Appreciate that SDCWA has participated in the Recycled Water process as a stakeholder, but it seems like there needs to be a broader discussion of this	As part of the SDCWA master plan (which is building upon the UWMP), the SDCWA will analyze the impacts of the Recycled Water Study IPR program. It is

**City of San Diego
Recycled Water Study
Final Draft Report Comment/Response Form**

NO.	REFERENCE	COMMENT	ACTION
		<p>project at SDCWA GM/Board level because of the deep implications for the region's water supply portfolio.</p> <p>If the City of San Diego is reducing purchase of imported water by such a significant amount, what will the impact of that be to other agencies SDCWA member agencies?</p> <p>Again, AWP has the potential to be a great water supply project for the region. Seems like there should be a broader regional discussion from the perspective of water suppliers. Not all Metro PAs are water agencies, so to date, they have likely not been closely following this study, but they are stakeholders and may have valuable thoughts on making it a viable project and advocating for implementation.</p>	<p>anticipated that the IPR program will have a similar affect on the SDCWA aqueduct system to other scenarios that delay the immediate need for infrastructure. This in turn will offset capital outlays by the SDCWA countering any impacts from reduced imported water. In addition, this program reduces the region's risk to future cost impacts such as the Bay-Delta fix and provides local water reliability important to agency revenues.</p> <p>Regarding SDCWA and member agency participation, an additional implementation step has been added to address financial partnership and broader policy issues.</p>
Poway 12	ES-1	<p>"Study Results and Conclusions"</p> <p>The first sentence in that paragraph is an awkward introduction. It does not feel like an opening sentence, rather like a concluding sentence or as if you are picking up in the middle of a document.</p> <p>I understand the value of beginning with the conclusions so they are right up-front for the reader, but perhaps the wording could be massaged so it doesn't feel like it was just cut and pasted from the end. The intro needs to be smoother.</p>	New intro added.
Poway 13	ES-17	The study shows Poway's total future recycled water use at 751 AF.	If Poway projections end up being less, than North City infill totals or increased initial capacity to San Vicente IPR will make up the difference. This has no material impact. The status update is appreciated.

**City of San Diego
Recycled Water Study
Final Draft Report Comment/Response Form**

NO.	REFERENCE	COMMENT	ACTION
		<p>Poway is assuming there will be no recycled water connection to serve north Poway. Poway's 2010 Urban Water Management Plan projects recycled water use to be 650 AF/year in 2025-2035.</p> <p>In 2010, the City of Poway purchased 251 AF of recycled water from San Diego, though recycled water customer demand was 499 AF. Poway's demand for recycled water does average closer to 428 AF as the study states.</p> <p>If Poway's demand never rises to 751 AF, would there be any negative impact for San Diego?</p>	
Poway 14	ES-30	<p>Typo; Fifth bullet under "Financials"</p> <p>Should say "Develop rate impacts." Delete "of."</p>	Revised
Poway 15		<p>There needs to be a corresponding summary document that's even briefer than the Executive Summary and written in less technical terms. The Executive Summary is helpful, but for general elected officials and the public, it would be helpful to have something that's more concise with a high-level description of outcomes. Ideal length would be no more than five pages with minimal jargon and simple charts.</p>	Noted.
Poway 16	B-8	<p>Cost Methodology FAQ</p> <p>"Gross costs include the capital and O&M costs..."</p> <p>How are O & M costs factored since those are annual costs?</p>	O&M costs are annual as noted, inflated, and then brought back as a net present value.
Poway 17	B-9	Cost Methodology FAQ	South Bay is complicated because it is both an "end-of-use" plant and a reuse plant. The Cost Methodology is

**City of San Diego
Recycled Water Study
Final Draft Report Comment/Response Form**

NO.	REFERENCE	COMMENT	ACTION
		Section on how South Bay reuse costs are calculated is hard to understand.	updated to try and clarify this point. The key issue is to finalize a cost sharing framework so final cost responsibilities can be determined between wastewater agencies (City/PAs) and water beneficiaries (City and potentially the SDCWA and member agencies).
Poway 18	Chapter 8 Page 8-3	Table 8-1 Last row lists El Monte Groundwater Recharge Project Is this project still happening? Thought I read in the paper that Helix decided to hold off on further pursuing this project.	It is currently on hold, but is still assumed to happen (potentially in a different form) at some time. Since we do not carry the costs for this project, its timing does not affect the Study or the Alternative Costs.
Poway 19	Chapter 8 Pages 8-6, 8-8 and 8-10	The Gant charts are confusing. Please clarify when the projects are expected to be fully implemented. Gant chart completion date looks like approximately 2031. Table 8-2 shows cumulative new water in 2021 as 85.8 MGD. Does that mean there is more "new water" between 2021 and 2031 when the project is fully implemented?	"Start" Date will be changed to "Start of Operations" and the dates will be adjusted accordingly to better describe when the offload starts. Once the facility begins operation, the flows are assumed to remain constant.
Poway 20	Chapter 8 Pages 8-6, 8-8 and 8-10	Tables 8-3, 8-6, 8-9 How do the cumulative costs from these tables correlate with the tables on pages 8-18 and 8-19?	Tables 8-3, 8-6 and 8-9 are phased capital and O&M costs based on 2011 dollars. These values feed into the financial model. Tables 8-15 and 8-16 are results from the NPV analysis after inflation, financing and timing are accounted for.
Poway 21	8.5.7 Page 8-24	"The follow-up meeting included a more detailed discussion of cost-sharing concepts. It was anticipated that these concepts could become the framework for a cost-sharing agreement between the City and the Participating Agencies." This statement sounds like the cost-sharing discussion	This implementation step has been re-phrased to "Complete discussions on cost share framework concepts and agreements, clarify City and Participating Agency costs, and clarify sources for offsets such as the salt credit."

**City of San Diego
Recycled Water Study
Final Draft Report Comment/Response Form**

NO.	REFERENCE	COMMENT	ACTION
		<p>is much farther along than the City of Poway perceives it to be. Poway still has many unanswered questions about the cost analysis and cost-sharing. The City of San Diego needs to make a concerted effort to have a collaborative discussion with a goal of developing a cost-sharing arrangement based on consensus.</p>	
Poway 22	8.5.7.1 Page 8-24	<p>“Value Assessment” section</p> <p>“Early in the implementation, recycled water costs will be higher than untreated water. The Wastewater system would be responsible for paying the difference between untreated water costs and the recycled water costs.”</p> <p>This is not an equitable approach. Does this mean that once the cost of untreated water is much higher than recycled water, the water customers are going to pay back the wastewater customers at a premium to reimburse for the up-front costs in this investment?</p> <p>There needs to be recognition that this is also an investment in a water supply diversification project, which means acknowledging an up-front cost on the water-side in return for the anticipated reliability and future water costs savings.</p>	Noted. This documents one concept conceptualized by a participant of the cost framework meeting. The cost approach used in the financial model does not assume this. See Poway 2.
Poway 23	8.5.7.1 Page 8-25	<p>Concept 2A and Concept 2B</p> <p>The positive benefit of the water supply reliability and long-term water cost savings seems to be just to the benefit of San Diego though all the PAs are helping to pay for that.</p>	See Poway 2. Other wastewater benefits may include deferral of secondary treatment or other cost reductions at Point Loma benefitting all the PAs. The reuse program is considered an important tool for the City and PAs to discuss future permit requirements at Point Loma with Environmental stakeholders.
Poway 24	8.5.7.2	Orange County Groundwater Replenishment District cost-sharing situation is different than this situation	Noted. This was one concept conceptualized by a participant. The cost approach used in the financial

**City of San Diego
Recycled Water Study
Final Draft Report Comment/Response Form**

NO.	REFERENCE	COMMENT	ACTION
	Page 8-25	because multiple agencies in OC are able to draw up the advance purified/replenished groundwater for treatment and use in their service area. That is not the same case for the San Diego area.	model does not assume this. See Poway 2.
Poway 25	8.5.9 Page 8-25	Harbor Drive facility – We understand that the City already owns this land, that there is already a large wastewater facility there, and that this site makes sense for a lot of different reasons. However, it also seems like prime real estate given its proximity to the bay, the airport, and downtown. It seems like we should really be asking if this is the site that makes the most sense to locate a major wastewater facility for the next 50-100 years. Is siting a major wastewater facility at this location consistent with the long-term vision for this area of San Diego? Are there any nearby areas with less prime real estate that might make more sense and still keep engineering costs low because of connectivity to existing infrastructure, like in the Rosecrans/I-5 area in the vicinity of the Midway Post Office?	This topic was brought up in the team meetings and the City evaluated alternative sites. This is included in Appendix E of the Report. An important next step is defining the Harbor Drive site so policy discussions can be held. This is included as an implementation step.
	Chapter 8 (pages 8-18 and 8-19)	<p>Annual Operating Costs vs. Capital Costs</p> <p>In interpreting the cost comparison chart for the different alternatives, it looks like the capital construction cost for the different options ranges from \$284 million to \$357 million.</p> <p>The annual operating costs looks like it ranges from \$139 million to \$183 million.</p> <p>Are we understanding this correctly? Is it true that the annual cost to operate is almost half of the cost to construct?</p>	These tables are summaries from the financial model. The capital costs you refer to are only the paygo portion. The debt financed portions are included above in operations since they are annualized costs. We will modify the label to clarify this. The capital and O&M costs are best seen on the two page summaries.

**City of San Diego
Recycled Water Study
Final Draft Report Comment/Response Form**

NO.	REFERENCE	COMMENT	ACTION
		If I have misunderstood the capital construction cost, that itself is a problem because it means that after studying the draft report for several hours, it's not clear to me how much the different options would cost. I appreciate that there are many variables affecting what the cost would be. Perhaps list the cost estimates as a range showing high/low possibility?	
Poway 26	Chapter 8 (pages 8-16 and 8-17)	In the cost scenarios, the Tier 3 net cost assumes PLWTP stays at CEPT. What is assumed is happening at PLWTP under the other scenarios?	For Tier 1 and Tier 2 (with the reuse program), Point Loma is assumed to be upgraded to secondary for the remaining flows (after IPR and diversion through SV08). At these flows, that is assumed to involve Biological Aerated Filters. Without the reuse program, full secondary at PLWTP includes BAF and high rate clarifiers.
Poway 27		Considerable more time needs to be spent on cost analysis/financing. From the PA's perspective, this is the most critical piece. The financing discussion in Chapter 8 and the FAQs is still hard to follow. The costs to the PAs are very ambiguous. The PAs need to be involved in this process as a key stakeholder. So far, it's felt more like our questions and requests for a meeting to clarify TM 8 have been received as a hindrance to the City of San Diego's tight-timeframe for this project rather than interest in a constructive dialogue.	See Poway 2. The Study does not commit any party to certain financial responsibilities, it only answers whether regional benefits should be derived and provides different concepts on cost sharing. The implementation step regarding negotiating fair and equitable terms will be important. Regarding TM8, there were a series of meetings on this material. Stakeholder Update Meeting 8 introduced the financial model, Stakeholder Update Meeting 9 was dedicated to TM8 topics and showing the model in real time, the Cost Sharing Workshop vetted cost sharing concepts. Implementation steps include further discussion on costs and cost sharing, recognizing that this is an important topic to both the City and PAs.
Poway 28		How will a decision be made on which of the five alternatives to pursue?	The Study does not recommend an alternative. It is assumed all five will be carried into the implementation stage for further evaluation.
Chula Vista			

**City of San Diego
Recycled Water Study
Final Draft Report Comment/Response Form**

NO.	REFERENCE	COMMENT	ACTION
CV1	Page ES-9, Measure 4	Measure 4 indicates that, after comparing previous analysis to the September 2011 Draft Wastewater Master Plan, the savings at the Point Loma Plant decreased but the costs in the South Bay decreased a similar amount. In costing the increased facilities required at the South Bay Plant, were there increases in the size of the primary and secondary facilities required and, if so, were these costs included in the comparison as Reuse Program costs? In addition, when do wastewater flow projections indicate the total planned diversion to South Bay would be attained?	<p>The latest revision involved an increase in Metro-generated wastewater flows totaling about 63 mgd (from 215 to 278 mgd). Since the capacities of the upstream recycled water facilities remained the same, the capacity of Point Loma and South Bay had to be increased to treat the additional flows.</p> <p>For PLWTP, the increase in flows causes the wastewater centric approach to require BAF and high rate clarifiers. The reuse centric approach only requires BAF. For South Bay, the wastewater master plan includes additional improvements, which lowers the reuse plan costs at this location. This facility is important for the cost split since it serves as a reuse facility and an end-of-line wastewater treatment plant. The study has looked at multiple scenarios and the costs generally remain within +/- \$200/AF. The key step will occur after the study in the cost sharing discussions.</p> <p>The full South Bay flows in the reuse program projected to be available at 2035 per Table 4-3. On average, the reuse program needs 30.4 mgd of influent wastewater. Per Table 3-4, this is already available with SV08.</p>
CV 2	Page ES-11, Direct Wastewater System Savings	Should this read: "to 2) the smaller Point Loma Plant size (<u>adjusted to a secondary treatment option</u>)" ?	Edited, but "adjusted" left out, since the base assumption in the Reuse Study starts with secondary.
CV 3	Page ES-11, Salt Reduction Credit	Where it says, "municipal treatment systems," should it read "municipal <u>water and wastewater</u> treatment systems"? If so, can the savings be apportioned between the two systems?	Added
CV 4	Page ES-17, Indirect Potable Re-	The first sentence says, "Three surface water augmentation projects" but only two are shown in	Revised

**City of San Diego
Recycled Water Study
Final Draft Report Comment/Response Form**

NO.	REFERENCE	COMMENT	ACTION
	use	the table.	
CV 5	Page ES-25, Flow Chart	Suggest adding a block titled South Bay Secondary Wastewater Treatment Plant since this will be a key component.	A footnote was added to note the coordination needed for South Bay between the Wastewater Master Plan and the Recycled Water Study.
CV 6	Page ES-30, Implementatio n Checklist	Suggest adding a step: Develop timeline for implementation steps including facilities projects.	Added
CV 7	Page ES-30, Implementatio n Checklist, Financials	Should <u>Water</u> Rate Payers be involved as well?	Revised
CV 8	Page ES-31	What is the Sweetwater River Crossing concept?	"Concept" removed. There is a crossing that needs to be evaluated.
CV 9	Page 2-1, Section 2.2	This says the Metro JPA will vote to adopt the revised plan. Won't the City of San Diego have to vote for it as well?	City will be added
CV 10	Page 4-1, Section 4.1, 1 st paragraph, last sentence	Figure 4-2 doesn't show "Totals for these facilities"	Reference removed
CV 11	Page 4-3, Section 4.2.1.1, 1 st paragraph	Suggest: "Wastewater in excess of the non-potable recycled water demands is <u>treated to secondary level and diverted.....</u> "	Revised
CV 12	Figure 4-7	Suggest enlarging; difficult to read.	Revised
CV 13	Page 8-2, Section 8.1.5, 2 nd paragraph	It would help to include a narrative description of how the costs remained consistent when additional flows were diverted to South Bay.	The Cost Methodology attempts to provide this.
CV 14	Pages 8-6 and	Should the note at the bottom of each page read:	Revised

**City of San Diego
Recycled Water Study
Final Draft Report Comment/Response Form**

NO.	REFERENCE	COMMENT	ACTION
	8-8	"Section 8.4" instead of "Section 8.5"?	
CV 15	Page B-6, Table B-3	This table indicates that the MER would be 9,942 mt/yr at secondary at 240 mgd and that the MER would be 7,898 mt/yr at the 40 mg/L CEPT at 143 mgd (The proposed flow after implementation of the Water Reuse Plan). Therefore, at 143 mgd, wouldn't 40 mg/L CEPT produce less mass emissions than it has in the past and less than it would at 240 mgd secondary? Also, it would help to include a graph of actual mass emissions for the past 10 years.	Revised as discussed in the Report Review meeting. Actual mass emission rates, influent TSS loading, PLWTP TSS removal efficiencies, and projected mass emission rates presented in the table are reported on a figure as discussed. In addition, a figure that presents the projected mass emission rate (assuming the PLWTP removes TSS at the average efficiency observed in the past 5 years) has been added. Edits provided in Appendix B and have been discussed with Scott Tulloch.
PA WHITE PAPER COMMENTS			
Otay	Bullet 3	Bullet 3 states that there is no market in South Bay. While there may not be a City of San Diego Market for the water there is Sweetwater, Cal Am and Otay in South Bay who could purchase the water.	Since additional non-potable reuse is included per Otay's request, please specify what this comment is requesting. Need more specifics to address further (such as page/section no.).
Padre Dam	Bullet 5	Why did the system flow increase so dramatically on their latest iteration? Going from 215 mgd system flow to 278 mgd system flow is very significant. This needs to be explained in a simple straight forward manner.	The 2050 projected metro system flow used in the August 2011 version of the RWS report used the projected annual average flow with a 2-year storm, which was not consistent with the Metropolitan Wastewater Master Plan currently being prepared by the PUD. The Master Plan uses an annual average flow that includes a 10-year storm event. This planning methodology has been previously approved by all PAs.
Implementation Comments			
1	ES30-32	The South San Diego County Water Reclamation Project (Project) is a comprehensive and coordinated approach by three public water agencies to sustainably use	The Recycled Water Study is based on current available information. Coordination will definitely need to take place in the future as their study progresses and determination as to the capacity of the SD formation is determined.

**City of San Diego
Recycled Water Study
Final Draft Report Comment/Response Form**

NO.	REFERENCE	COMMENT	ACTION
		<p>the apparently vast groundwater resources of the San Diego Formation (SD Formation) by developing a new Brackish Groundwater Desalination facility, and a multi-purpose Concentrate Conveyance facility. Current estimates indicate that the SD Formation holds upward of 1,000,000 acre-feet (AF) of water, but currently produces only about four million gallons per day (MGD) of desalinated brackish water and two MGD of potable well water within Sweetwater Authority's service area. The Project also includes development of recycled water via Membrane Bioreactor (MBR) technology, reducing the wastewater load to the regional wastewater treatment facility. The Sweetwater Authority, Cities of Chula Vista and National City, California, and the Otay Water District (Partners) are the local sponsors of the Project. As part of implementation coordination should start with these agencies to use excess water produced by the South Bay Plant as an Orange County style project for ground water injection into the San Diego Formation,</p>	
2	ES30-32	<p>The USGS is currently completing a study of the San Diego Formation which will provide key data concerning the capacity of the Formation, its rate of recharge, and long term sustainable use. Once this study is completed a new study</p>	<p>The implementation steps currently include updating future plans based on ongoing groundwater evaluations.</p>

**City of San Diego
Recycled Water Study
Final Draft Report Comment/Response Form**

NO.	REFERENCE	COMMENT	ACTION
		should integrate ground water injection (Orange County style project) with the plan for South Bay and the use of 65 MGD of treated water as discussed in the Recycled Water Study.	
3	ES30-32	The Peer Review cited on Page 2 Item 1.6 of the Cooperative Agreement between the City of San Diego and the Environmental Community needs to be completed as soon as possible.	The City is in communication with the environmental community.
4	ES30-32	Further study by San Diego PUD staff and possibly an outside consultant of the 278 mgd versus 215 mgd at Point Loma needs to be accomplished to see if the planning data needs to include a ten-year rain event. The additional 31 mgd drastically increases the cost of taking Point Loma to secondary if that is required.	Noted. Item will be discussed with Metropolitan Wastewater Department of PUD.
5	General	That all implementation comments made at the stake holders meeting by all parties will be incorporated into the final draft in the executive summary and the revised final draft report.	This has been the intent provided that the comments are aligned with the goals of the study and are supported by the broader Stakeholder group.
SURFRIDER			
Surf-1	ES-9	Suggested language change is in bold: Measure 4: "Leading up to the Fine Screening Session, a reuse/ Point Loma offload target of approximately 100 mgd was established to maximize cost savings by avoiding upgrades for over 200 mgd at the Point Loma Plant. This comment is attempting to bring in more of the cost/benefit jump information that was present in previous versions.	Section 8.1.5 of the report was updated to describe further. Per conversation with Julia at the Report Review Session, the new flows do not permit avoiding eth BAF jump.
Surf-2	ES-30	Two reference on this page (Mayor and City Council	Added "full-scale" per conversation with Julia at the

**City of San Diego
Recycled Water Study
Final Draft Report Comment/Response Form**

NO.	REFERENCE	COMMENT	ACTION
		paragraph and Financials paragraph) make it seem like it is an “either or” decision between upgrading Point Loma and implementing the Reuse Program. It’s also possible that implementing the Reuse Program makes upgrading Point Loma for the remaining flow more feasible and affordable.	Report Review Session.
Surf-3	8.1.5	Does it have to be either or? Can’t the water reuse projects be implemented and the City may still choose to upgrade the remaining flow at Point Loma? Regardless of whether the remaining flow is treated to secondary standards or not, implementing the Water Reuse Program will make treatment at Point Loma more feasible and affordable.	See Surf-1
Surf-4	8.5.3	Suggestion to add bolded language: “While the reuse Program appears to offer substantial cost savings to ratepayers (compared to upgrading over 200 MDG to secondary treatment at the Point Loma Plant), support from the policymakers to advance the program will be needed. The following summarized these key Mayor and City Council implementation steps”	See Surf-2
Surf-5	8.5.8	“The City, the Participating Agencies, the EPA, and the Stakeholder groups will be key participants in addressing the Point Loma Plant as the reuse plan is implemented. The plan assumes that any secondary treatment upgrades (if required) at the Point Loma Plant would be completed at the end of the reuse implementation period when firm reuse totals are achieved. This approach would allow determining the actual solids mass emission rates occurring after the new reuse projects offload flows to the Point Loma Plant and after solids are removed and sent	Modified per the discussion at the Report Review Session

**City of San Diego
Recycled Water Study
Final Draft Report Comment/Response Form**

NO.	REFERENCE	COMMENT	ACTION
		<p>to the Met Biosolids Center. Although the study looked at both secondary treatment and CEPT approaches at the Point Loma Plant, making a determination on CEPT would clarify the avoided facilities savings element associated with the financial evaluation section above.”</p> <p>Please provide references; when was this decided? Does this belong in this study? Does this imply that if secondary is required, it would not be implemented until 2035?</p>	
Surf-6	General	During the implementation phase, the City should explore more beneficial uses for the concentrated discharge.	Added to the waste stream implementation step
Surf-7	General	I wish there was a way to bring the info from table 8.1 in the Aug 2011 version forward to articulate the jump in savings. Although the numbers have changed due to coordination with the Waste Water Management Plan. The info contained in the old Table 8.1 is good to reference.	See Surf-1
PADRE DAM			
PD1	Pg ES-15	In the Area Concept Summary Table, for the San Vicente/North City Area under the column for Additional Consideration after Stakeholder Review, add the Santee Basin Aquifer Project which is currently under study by the Bureau of Reclamation for Padre Dam Municipal Water District. Preliminary planning number put the capacity of the first site considered to be between 1.5 mgd and 3 mgd of groundwater recharge capacity. Suggested Action - Add the Santee Basin Aquifer to the column for Additional Consideration after Stakeholder Review.	This table lists what was considered at that point in the project. Since the Santee Basin Aquifer project was not part of the area concepts development it is not included in that table but has been added to the list of implementation steps.
PD2	Pg ES-15	In the Area Concept Summary Table, for the San	This table lists what was considered at that point in the

**City of San Diego
Recycled Water Study
Final Draft Report Comment/Response Form**

NO.	REFERENCE	COMMENT	ACTION
		Vicente/North City Area under the column for Additional Consideration after Stakeholder Review, add that the Helix Water District is also considering an option to send advanced treated recycled water to their Lake Jennings Reservoir as part of a reservoir augmentation IPR project. Suggested Action - Add the Helix Water Districts Lake Jennings Reservoir Project to the column for Additional Consideration after Stakeholder Review.	project. Since the Helix IPR project was not part of the area concepts development it is not included in that table but has been added to the list of implementation steps.
PD3	Pg ES-17	Under the Table for Indirect Potable Reuse Projects Advanced, under Surface Water Reservoir Candidates Advanced to the Fine Screening Session, add the Helix Water District Lake Jennings Reservoir Augmentation IPR project. Suggested Action - Add to the Table and to the text a discussion on use of Lake Jennings for an IPR project.	This table lists what was advanced from the coarse screening session to the fine screening session. The Helix project was not discussed at that point of the project and has not been added to the table. This project has been added as an implementation step however.
PD4	Pg ES-17	Under the Table for Indirect Potable Reuse Projects Advanced, under Groundwater Augmentation Projects by Others Considered, add the Santee Basin Aquifer Project which is currently under study by the Bureau of Reclamation for Padre Dam Municipal Water District. Preliminary planning number put the capacity of the first site considered to be between 1.5 mgd and 3 mgd of groundwater recharge capacity. Suggested Action - Add to the Table and to the text a discussion on use of Santee Basin Aquifer Project.	See response to comment above.
PD5	Pg ES-18	The bulleted text, "3" Sub-Alternative states "Alternative "B3" is the same as Alternative "B2", except that it included a small plant in Mission Gorge to collect, treat and convey water to the San Vicente Reservoir. This adds a fourth plant, but it is the closest location to the San Vicente Reservoir." Alternative B3 does not add a fourth plant but expands the Padre Dam WRF currently planned to serve local non-potable water demand plus the EI	The location of this plant has not been determined but a siting analysis is included as an implementation step.

**City of San Diego
Recycled Water Study
Final Draft Report Comment/Response Form**

NO.	REFERENCE	COMMENT	ACTION
		<p>Monte Groundwater Project.</p> <p>The current plan for Padre Dam WRF to accommodate non-potable and El Monte demands is to expand the existing 2.0 mgd plant to approximately 10 mgd. All alternatives in this study require that a minimum 10 mgd plant be constructed to accommodate these flows. In order to produce 6.8 mgd of IRP water to be sent to San Vicente (under alternative B3) an additional 8.7 mgd of plant influent capacity would be needed for a total of 18.7 mgd raw wastewater influent capacity. Suggested Action - Remove text that says a fourth plant would need to be constructed (enlargement of the currently planned Padre Dam WRF from 10 mgd to 18.7 mgd would be needed).</p>	
PD6	Pg ES-20 & 21	<p>El Monte Valley Groundwater Basin Project is an additional 5 mgd off load to Point Loma. El Monte Valley Groundwater Basin flow of 5 mgd is not shown on Reuse by Phase Graph, Reuse Per Plant Graph, Implementation Schedule Graph, Table showing Off Loads, and Table showing Capital and O&M Costs per Phase. Suggested Action - Add El Monte Valley Groundwater Recharge Project to all Graphs and Tables in this Section.</p>	<p>These graphs only show the projects costed in this study. The El Monte project is noted in the footnote.</p>
PD7	Pg ES-22 & 23	<p>El Monte Valley Groundwater Basin Project is an additional 5 mgd off load to Point Loma. El Monte Valley Groundwater Basin flow of 5 mgd is not shown on Reuse by Phase Graph, Reuse Per Plant Graph, Implementation Schedule Graph, Table showing Off Loads, and Table showing Capital and O&M Costs per Phase. Suggested Action - Add El Monte Valley Groundwater Recharge Project to all Graphs and Tables in this Section.</p>	<p>see PD6</p>

**City of San Diego
Recycled Water Study
Final Draft Report Comment/Response Form**

NO.	REFERENCE	COMMENT	ACTION
PD8	Pg ES-24 & 25	<p>El Monte Valley Groundwater Basin Project is an additional 5 mgd off load to Point Loma. El Monte Valley Groundwater Basin flow of 5 mgd is not shown on Reuse by Phase Graph, Reuse Per Plant Graph, Implementation Schedule Graph, Table showing Off Loads, and Table showing Capital and O&M Costs per Phase. By combining the offload that would be generated by the additional demands of El Monte, PDMWD's RW demands, PDMWD facility could be expanded to 18 to 20 MGD to achieve the economy of scale comparable to other options outlined in this study. Suggested Action - Add El Monte Valley Groundwater Recharge Project to all Graphs and Tables in this Section.</p>	see PD6
PD9	ES-11?	<p>With regard to the Salt Credit of \$100/AF, all water customers within the region will benefit from reduced salt concentration. Note that the IPR water placed into San Vicente Reservoir is a shared facility with the CWA and the City of San Diego. Reduction of salt would be a benefit to the region; therefore, salt credit must be paid for by all customers that receive the benefits of reduced salt in the potable water supply. Additionally, CWA should be consulted extensively regarding the viability of providing this credit to the project. Suggested Action - Address regional impacts of implementing salt credit in the fairest and reasonable manner including the CWA.</p>	<p>The salt credit is similar to the Point Loma offload benefit. By doing reuse, you avoid a cost somewhere else in the system. The credit of this would be from the downstream water system (City and SDCWA agencies served by San Vicente) and wastewater system (Metro). The crediting of this money would need to be worked out. This has been added to the implementation checklist.</p>
PD10	Pg ES-28	<p>Under discussion on Alternative B3 it states that the technical complexity is "High (4th Water Reclamation Plant/Advanced Water Purification Facility at Mission Gorge)", and that the "Mission Gorge Plant is relatively small due to limited tributary wastewater flows."</p>	<p>An implementation step has been included to determine the siting of new facilities, including the Mission Gorge facility. It has not yet been determined that it will be co-located at the Padre Dam WRF site. This is an implementation step that requires further evaluation.</p>

**City of San Diego
Recycled Water Study
Final Draft Report Comment/Response Form**

NO.	REFERENCE	COMMENT	ACTION
		<p>Alternative B3 does not add a fourth plant but expands the Padre Dam WRF currently planned to serve local non-potable water demand plus the El Monte Groundwater Project.</p> <p>The current plan for Padre Dam WRF to accommodate non-potable and El Monte demands is to expand the existing 2.0 mgd plant to approximately 10 mgd. All alternatives in this study require that a minimum 10 mgd plant be constructed to accommodate these flows. In order to produce 6.8 mgd of IRP water to be sent to San Vicente (under alternative B3) an additional 8.7 mgd of plant influent capacity would be needed for a total of 18.7 mgd raw wastewater influent capacity. Expanding the plant from 10 mgd to 18.7 does not add technical complexity nor is it a small plant with regard to other plants proposed under this alternative. Suggested Action - Revise text.</p>	
COMMENTS ON MAIN BODY OF REPORT			
PD11	General	<p>This study still did not discuss how much IPR Water San Vicente can take. What is the City's contingency plan if the regulatory framework is more restrictive? Where is the offload then? Suggested Action - Address.</p>	<p>The amount of IPR water SVR can take from a regulatory view is discussed in TM 5 and summarized in Chapter 6, Table 6-1. The regulatory environment is dynamic, with uniform criteria on reservoir augmentation due out in 2016. The City's Water Purification Demonstration Project will also provide important metrics on permit constraints. Multiple implementation steps address this, including updates on current groundwater evaluations and evaluation of the feasibility of serving smaller reservoirs based on new regulations. The phasing of the projects allows these issues to be addressed as the Study is implemented.</p>
PD12	General	<p>There are significant avoided costs by diverting flow into Padre Dam's facility including pending upgrades and</p>	<p>An implementation step has been added to evaluate the merits of a joint PDWRF/MG plant. The offloads and</p>

**City of San Diego
Recycled Water Study
Final Draft Report Comment/Response Form**

NO.	REFERENCE	COMMENT	ACTION
		<p>rehabilitation of the sewer force main and Mission Gorge Pump Station. This cost avoidance should be recognized in the report as they represent significant savings to the Participating Agencies. Suggested Action - Add avoided cost for not proceeding with the rehabilitation of the force main and Mission Gorge Pump Station with alternative B3.</p>	<p>need to upgrade the MG PS and FM could be part of this evaluation. This option would also need to address failsafe and waste stream disposal which may require some of the pending improvements.</p>
PD13	General	<p>Note that the proposed expansion at Padre Dam in association with the El Monte Project would result in offloading of the PLWTP by 5 mgd. This would result in significant cost savings to the Participating Agencies and the City of San Diego. Costs for offloading the PLWTP by expanding the Padre Dam facilities to recharge the El Monte Project should be recognized in all themes presented in this report. Suggested Action - Discuss sharing of cost savings with Padre Dam MWD as related to capital and O&M costs.</p>	<p>The Study does not include the costs or take credit for the El Monte Valley project. It coordinated the projects such that there was enough flow. The benefits from building such a project could be negotiated similar to the cost sharing discussion planned for the projects included in this Study. Since the El Monte project is on hold, this seems like a mute point until it becomes imminent again.</p>
PD14	General	<p>Land acquisition and environmental difficulties for the Harbor Drive site are significant. The Padre Dam facility already has land and has treated wastewater at its current location for over 50 years. Therefore, expansion of the Padre Dam facility would have less environmental and community impacts than the Harbor Drive option.</p> <p>Pumping costs from Harbor Drive to San Vicente are also much greater than from the Mission Gorge site.</p> <p>Suggested Action - Provide a more realistic cost estimate on environmental related mitigation cost for the Harbor Drive option vs. the Padre Dam Expansion option.</p> <p>Provide a more realistic energy cost savings associated with the Padre Dam option versus the Harbor Drive</p>	<p>The City owns the HD site. This topic was brought up in the team meetings and the City evaluated alternative sites. This is included in Appendix E of the Report. An important next step is defining the Harbor Drive site so policy discussions can be held. This is included as an implementation step. It is important to note that the Mission Gorge site alone does not produce the volume of offload at Point Loma desired by Stakeholders. Therefore, the plan is not an either-or regarding Harbor Drive.</p> <p>The IRA B3 includes the mission gorge plant and all costs related to pumping from the MG site to SVR (and therefore, less IPR pumping from HD) have been accounted for. This option has other factors that affect the cost including the conveyance of waste streams. An implementation step is included to evaluate this area further..</p>

**City of San Diego
Recycled Water Study
Final Draft Report Comment/Response Form**

NO.	REFERENCE	COMMENT	ACTION
		option.	
PD15	4.1	Levy Treatment Plant demand is not addressed. Suggested Action - Add Levy Treatment plant to the discussion.	The primary IPR deliveries screened reviewed during the Study were to San Vicente and Otay Lakes. There is an implementation step to consider smaller lakes as regulations evolve. Lake Jennings has been added to the list per your comments.
PD16	Pg. 4-1	Reference was made to Figure 4-2 showing totals for the Potable Treatment Plants. Suggested Action - Add this Figure including the total for Levy Treatment Plant.	See PD15. In addition, this Figure no longer is included in the report.
PD17	Figure 4-3	Annual Average line is not shown Suggested Action - Add	The average annual values are provided below the bar chart.
PD18	4.2.1.3	Discuss that Padre Dam is currently working with the Bureau of Reclamation in studying another location in the Santee Basin for Ground Water Recharge of highly treated recycled water. The capacity for IPR water at this site range from 1.5 mgd to 3 mgd. There may be other locations within the El Monte/Santee Basin where highly treated recycled water could be used to create new water. Suggested Action - Add a discussion on additional locations in the Santee Basin for development of groundwater recharge using highly treated recycled water.	Added sentence that PD is also evaluating GW recharge in the Santee basin.
PD19	4.2.2	Conveyance systems were described for both the City of San Diego's and Otay's recycled water distribution systems but not for Padre Dam's system. Suggested Action - Add a description of Padre Dam's recycled water conveyance system.	Additional details added to 4.2.1.3. Section 4.2.2 describes the City's recycled water system expansion which is connected to the Metro treatment plants. This section mentions Otay since it is directly connected.
PD20	Figure 4-10	Annual Average line is not shown. Suggested Action - Add the annual average flowrate to aid in the text discussion.	Assume this is a reference to Figure 4-9. Average annual flow values are provided below the graph.
PD21	Table 4-2	Mission Gorge Flow was added to be 0 to 9 mgd based on alternative being studied. Suggested Action - If PDMWD and HWD abandon the El Monte GW Recharge Project, a combined East County Facility	The 5 mgd offload from the El Monte Valley project is coordinated with the Study. Expanding the San Vicente flows further fall under possible implementation steps and tie to regulatory limits at San Vicente.

**City of San Diego
Recycled Water Study
Final Draft Report Comment/Response Form**

NO.	REFERENCE	COMMENT	ACTION
		could offload more wastewater flow than stated. Additionally, even if the El Monte GW project moves forward, the project would offload additional flows to Metro system that the City should recognize.	
PD22	Figure 4-12	There is no identifying site number for the East Mission Gorge Pump Station. Associated flow for this location should also be identified. Suggested Action - Add a Site Number N13 at the East Mission Gorge Pump Station.	In figure 4-11 the East MG PS is identified as N9.
PD23	Table 5-1	What about peak RW demands? What about utilizing seasonal storage as a mean to accommodate peak demands rather than building more treatment capacity? Suggested Action - Add a discussion on how you planned on meeting peak demands and consideration for seasonal storage.	Seasonal storage was addressed in previous comments. No seasonal storage is included in the Study.
PD24	Figure 5-2	Do not see areas served by the new Treatment Plant Suggested Action - More clearly identify areas served by new Treatment Plants.	Figure 5-2 is a density map showing the NPR demands. This map does not show areas served by treatment facilities.
PD25	5.3.2	In discussing Future Wholesale Non-potable Recycled Water Opportunities, there was no discussion on how seasonal storage (if constructed) could allow service to this untapped demand without constructing new treatment capacity. Suggested Action - Add discussion on how seasonal storage could aid in allowing the North City Plant meet additional recycled water demand for these future wholesale clients.	See PD23
PD26	5.4.1	The fourth sentence of the first paragraph states "This generally means that the treatment plant capacity must be two times larger than the average demands resulting in potentially underutilized capacity at the treatment plants." This is not true if you implement seasonal storage. Suggested Action - Add seasonal storage to the discussion to aid in reduction in treatment plant size.	See PD23

**City of San Diego
Recycled Water Study
Final Draft Report Comment/Response Form**

NO.	REFERENCE	COMMENT	ACTION
PD27	Table 6-1	Lake Jennings should be added, discuss with Helix Water District. Suggested Action - Add Lake Jennings as a Surface Water Reservoir Candidate.	Table 6-1 lists the reservoirs advanced during this Study to the Coarse Screening Session. Lake Jennings was not advanced. Lake Jennings has been added to the implementation step involving evaluating smaller reservoirs per your comment.
PD28	Table 6-2 Surface Water Reservoir Candidates Not Advanced	For the Jennings reservoir, the first Key Consideration was that the reservoir is "Too small to meet anticipated regulatory requirements;....". The relative small size would just reduce the capacity of this alternative compared to a larger reservoir, not prevent it from meeting regulatory requirements. Suggested Action - Revise text	See PD27
PD29	Table 6-2 Surface Water Reservoir Candidates Not Advanced	For the Jennings reservoir, the last sentence under Key Considerations states "As the regulatory environment for indirect potable reuse evolves, these requirements may become feasible." Lake Jennings will be subject to the same regulatory requirements as will San Vicente (size is not the issue). Suggested Action - Revise text which discounts an IRP project at Lake Jennings from meeting regulatory requirements due to size.	See PD27
PD30	6.3.2	Ground Water Recharge Opportunities Considered. The first bulleted item is El Monte Valley. This should also include the Santee Basin. Suggested Action - Revise the text for the first bulleted item to be "El Monte Valley/Santee Basin	Although Padre Dam noted their interest in the Santee Basin, the City feels this alternative was not vetted and discussed in the Study and needs further discussion between the two parties.
PD31	Table 6-3	Padre Dam is currently working with the Bureau of Reclamation in studying another location in the Santee Basin for Ground Water Recharge of highly treated recycled water. The capacity for IPR water at this site range from 1.5 mgd to 3 mgd. There may be other locations in the Santee Basin where highly treated recycled water could be used to create new water. Suggested Action - Add a discussion on additional locations in the Santee Basin for development of	See PD30

**City of San Diego
Recycled Water Study
Final Draft Report Comment/Response Form**

NO.	REFERENCE	COMMENT	ACTION
		groundwater recharge using highly treated recycled water.	
PD32	Figure 7-3	Instead of showing a Mission Gorge Plant near what appears to be the location of the Mission Gorge Pump Station, show the Plant to be at the site of the Padre Dam WRF. Suggested Action - Revise location of the Mission Gorge Plant to be at the site of the Padre Dam WRF.	The site of this plant has not been determined. An implementation step is included to evaluate the siting of new facilities.
PD33	Table 7-2	North City/San Vicente Area Concept Summary – 2035. Where is the 7 mgd raw flow needed for the El Monte Valley Groundwater Recharge Project? Suggested Action - Add the flow needed to supply water for the El Monte Valley Ground Water Recharge Project.	Bullet point 4 addresses that the flows were accounted for.
PD34	Figure 7-5	Show Padre Dam WRF location for general reference. Suggested Action - Add location on Figure.	Revised
PD35	Figure 7-6	Show Padre Dam WRF location for general reference. Suggested Action - Add location on Figure.	Revised
PD36	8.2	<p>On page 8-5, “3” Sub-alternative states “Alternative “B3” is the same as Alternative “B2”, except that it included a small plant in Mission Gorge to collect, treat and convey water to the San Vicente Reservoir. This adds a fourth plant, but it is the closest location to the San Vicente Reservoir.” Alternative B3 does not add a fourth plant but expands the Padre Dam WRF currently planned to serve local non-potable water demand plus the El Monte Groundwater Project.</p> <p>The current plan for Padre Dam WRF to accommodate non-potable and El Monte demands is to expand the existing 2.0 mgd plant to approximately 10 mgd. All alternatives in this study require that a minimum 10 mgd plant be constructed to accommodate these flows. In order to produce 6.8 mgd of IRP water to be sent to</p>	See PD10.

**City of San Diego
Recycled Water Study
Final Draft Report Comment/Response Form**

NO.	REFERENCE	COMMENT	ACTION
		San Vicente (under alternative B3) an additional 8.7 mgd of plant influent capacity would be needed for a total of 18.7 mgd raw wastewater influent capacity. Suggested Action - Remove text that says a fourth plant would need to be constructed (enlargement of the currently planned Padre Dam WRF from 10 mgd to 18.7 mgd would be needed).	
PD37	Table 8-5	El Monte Valley Groundwater Basin Project is an additional 5 mgd off load to Point Loma. El Monte Valley Groundwater Basin flow of 5 mgd is not shown on Reuse by Phase Graph, Reuse Per Plant Graph, Implementation Schedule Graph, Table showing Off Loads, and Table showing Capital and O&M Costs per Phase. Suggested Action - Should PDMWD and HWD suspend or abandon the El Monte Project, additional offload to PLWWTP will be required; this study should consider this alternative.	see PD6
PD38	Table 8-8	El Monte Valley Groundwater Basin Project is an additional 7 mgd off load to Point Loma. El Monte Valley Groundwater Basin flow of 5 mgd is not shown on Reuse by Phase Graph, Reuse Per Plant Graph, Implementation Schedule Graph, Table showing Off Loads, and Table showing Capital and O&M Costs per Phase. By combining the offload that would be generated by the additional demands of El Monte, PDMWD's RW demands, PDMWD facility could be expanded to 18 to 20 MGD to achieve the economy of scale comparable to other options outlined in this study. Suggested Action - Wastewater offloaded for the El Monte Project should be considered by this study as any wastewater offloaded by Participating Agency would result in savings	see PD6
PD39	Table 8-9	The capital and O&M costs for the Mission Gorge Plant are too high and not consistent with current O&M costs for the Padre Dam Water Recycling Facility and the	This is a regional study with a consistent cost methodology applied to all facilities. Specific site evaluations to look for cost efficiencies are considered

**City of San Diego
Recycled Water Study
Final Draft Report Comment/Response Form**

NO.	REFERENCE	COMMENT	ACTION
		Black & Veatch Planning Study(s). Suggested Action - Revise unit cost and extended amounts in the detailed cost estimate to be consistent with previous studies.	implementation steps. This includes the Mission Gorge area.
PD40	Table 8-11	<p>Alternative B3, Key Infrastructure Siting and Complexity Considerations:</p> <p>“Mission Gorge Plant is relatively small due to smaller tributary wastewater flows limited and reduces Harbor Drive Plant economy of scale”. The Padre Dam WRF (Mission Gorge Plant) is only small if you don’t consider flows required for the El Monte Project. If a combined plant is envision, the East County option could be a 18 to 20 mgd facility which would improve the economy of scale significantly.</p> <p>Reduced flow downstream of Mission Gorge facility would allow significant savings to replace existing Metro sewer facilities and would decrease maintenance issues; not increase maintenance issues.</p> <p>Suggested Action - Revise text.</p>	This is a new concept since the El Monte Valley project was assumed to occur during the Study. Any new concepts can be considered during implementation.
PD41	Table 8-13	Salt Reduction Credit. Discussion does not explain how the \$100/acre foot credit would work. As the IPR water entering the San Vicente and Otay Reservoirs would benefit both the County Water Authority and the City of San Diego, would a credit be paid from these agencies to the wastewater side? Suggested Action - Although the report indicated that this is a projected savings in equipment costs in water facilities; it does not decrease overall cost of the project. The method of applying this credit needs to be practical or the benefit should not be claimed in the financial analysis.	See PD-9
PD42	Table 8-15	Column for Theme B3. The capital and O&M costs for the Mission Gorge Plant is too high and not consistent	See PD39

**City of San Diego
Recycled Water Study
Final Draft Report Comment/Response Form**

NO.	REFERENCE	COMMENT	ACTION
		<p>with current O&M costs for the Padre Dam Water Recycling Facility and the Black & Veatch Planning Study(s). Suggested Action - It appears that the cost estimates have changed significantly; however, no details are given to review and inputs.</p>	
PD43	Detailed Cost Estimate Spreadsheet, Theme B3	<p>Padre Dam Expansion (Mission Gorge) Upgrades/Improvements for MBR uses a unit cost of \$7,400,528 per MGD and the Harbor Drive uses a unit cost of \$4,088,670 per MGD.</p> <p>Similar high unit costs were used for the preliminary, primary treatment processes and AWTP. The detailed cost breakdown showed that the Padre Dam Option is twice the cost as the Harbor Drive Option. Studies completed by Padre Dam in the recent past reflected much lower cost per MGD to construct all facilities.</p> <p>O&M cost inclusive of AWTP for the Mission Gorge Facility showed an O&M cost of \$1.28M/MGD while the Harbor Drive Option has an O&M cost of \$0.69M/MGD. Currently, Padre Dam facility has an O&M cost structure on par with the PLWTP O&M cost on a per MGD treated basis even though it is much smaller plant and Padre Dam treats its wastewater to a higher level standard than the PLWTP. Additionally, PDMWD's facility is only 2 MGD compared to PLWTP rated 240 MGD facility. Therefore, additional justifications should be provided other than using a theoretical economy of scale curve.</p> <p>Suggested Action - It appears that the cost estimates have changed significantly; however, no details are given to review and inputs.</p>	See PD39

**City of San Diego
Recycled Water Study
Final Draft Report Comment/Response Form**

NO.	REFERENCE	COMMENT	ACTION
		<p>Padre Dam's prior study showed that cost per MGD of MBR is closer to the cost associated with Harbor Drive Option. Revise cost to reflect lower capital cost for Theme B3.</p> <p>Again, Padre Dam prior studies showed that capital costs for all aspect of capital improvements are in similar order magnitude as the Harbor Drive cost option. Revise cost assumption to reflect similar cost structure.</p> <p>Revise O&M costs to reflect a more realistic estimate between options. Currently, PDMWD is treating wastewater to secondary level at a lower cost than the City is treating to advanced primary level on a per MGD basis without the benefits of economy of scale.</p>	
PD44	Detailed Cost Estimate Spreadsheet, Theme B3	<p>Collection system improvements, under Pump Stations; EMGPS is \$20M for 10 mgd and the Harbor Drive Station is \$28M for 46 mgd. The EMGPS was originally designed with consideration for pumping this wastewater to the Padre Dam WRF site; therefore improvement costs for the EMGPS should be much lower per mgd than the Harbor Drive estimate.</p> <p>Suggested Action - It appears that the cost estimates have changed significantly; however, no details are given to review and inputs.</p>	See PD39

APPENDIX K: CONCEPTUAL METRO SYSTEM FLOW SCHEMATICS



This page intentionally left blank.

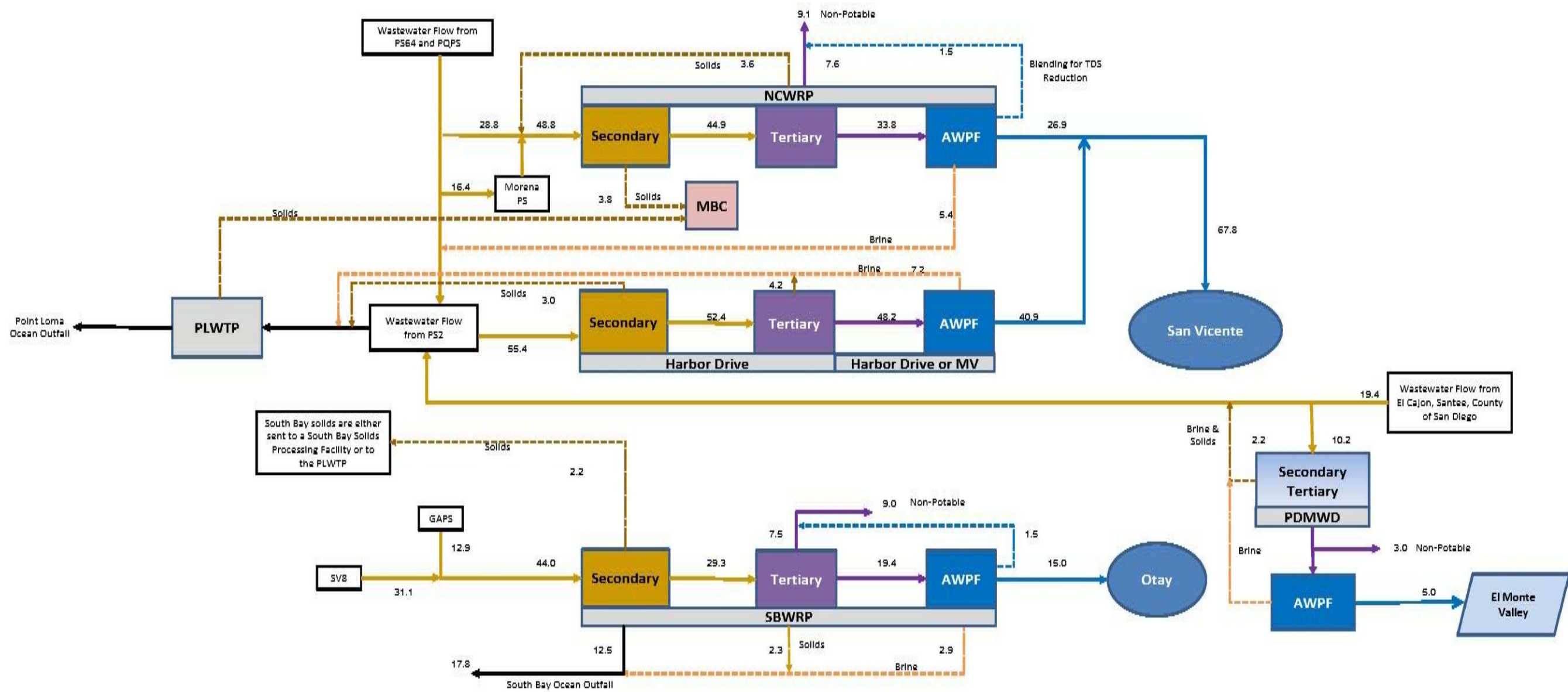

Figure K-1. Theme A1/A2 Conceptual Flow Schematic

Notes: Totals shown represent average 2035 dry weather flows in million gallons per day. The South Bay and Point Loma facilities will need to be sized to handle the peak wet weather flows (not shown on schematic). Solids will either be delivered to Point Loma/Metro Biosolids Center or to a new Southern Solids Processing Facility at South Bay.

This page intentionally left blank.

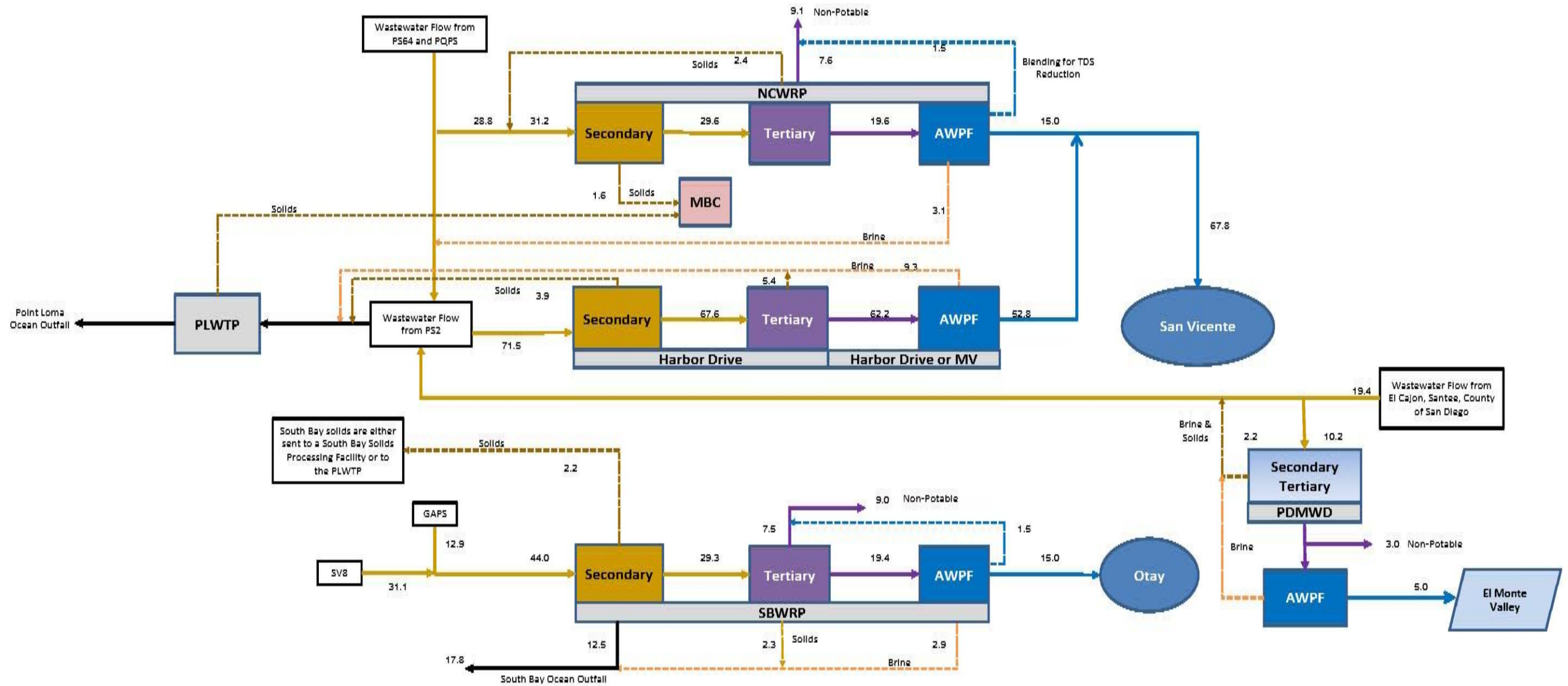

Figure K-2. Theme B1/B2 Conceptual Flow Schematic

Notes: Totals shown represent average 2035 dry weather flows in million gallons per day. The South Bay and Point Loma facilities will need to be sized to handle the peak wet weather flows (not shown on schematic). Solids will either be delivered to Point Loma/Metro Biosolids Center or to a new Southern Solids Processing Facility at South Bay. The initial North City Plant IPR water flow ranges from 11 mgd to 18 mgd.



This page intentionally left blank.

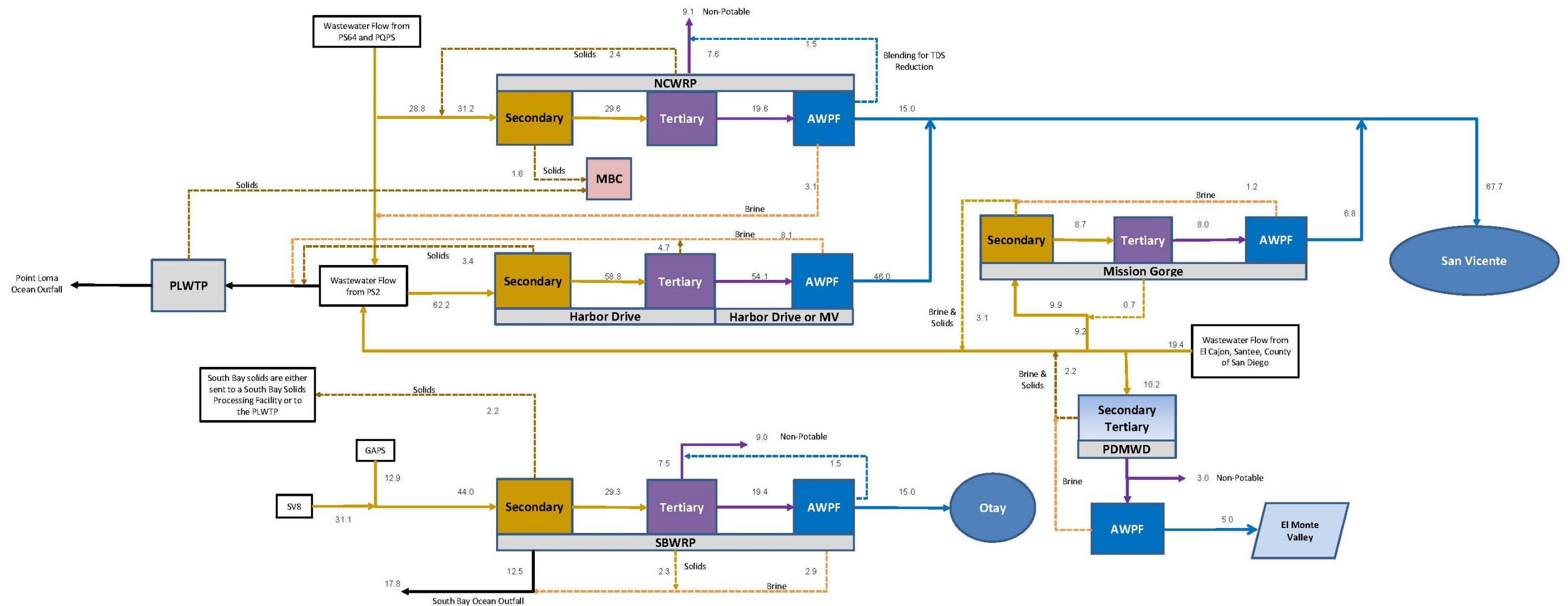

Figure K-3. Theme B3 Conceptual Flow Schematic

Notes: Totals shown represent average 2035 dry weather flows in million gallons per day. The South Bay and Point Loma facilities will need to be sized to handle the peak wet weather flows (not shown on schematic). Solids will either be delivered to Point Loma/Metro Biosolids Center or to a new Southern Solids Processing Facility at South Bay. The Mission Gorge Plant could be co-located with the planned Padre Dam MWD AWPF facility.



This page intentionally left blank.

APPENDIX L: METRO JPA LETTER



This page intentionally left blank.



Ernest Ewin, Chairman

www.metrojpa.org

June 7, 2012

Ms. Marsi A. Steirer
Deputy Director
Water Recourses and Planning
City of San Diego Public Utilities Department
600 B Street, MS 906
San Diego, CA 92101

Re: Metro Commission/JPA Acceptance of the Recycled Water Study

Dear Marsi:

In August 2009, the City of San Diego (San Diego), along with key stakeholders, including representatives from the Participating Agencies (PAs), initiated the Recycled Water Study (Study). The Study is intended to serve as a guidance document in helping policy leaders make the important decisions ahead regarding water reuse and the region's water and wastewater infrastructure.

The Study process was very collaborative and included a number of technical evaluations and coordination steps to identify and evaluate reuse alternatives within San Diego as well as areas served by the Participating Agencies. Throughout the Study, regular Stakeholder Status Update meetings were held to present progress and to receive input and feedback on the activities. Eight technical memoranda were developed to document information.

We accept the San Diego Recycled Water Study dated May 3, 2012. With this acceptance we acknowledge that this Study provides valuable foundational data on Indirect Potable Reuse (IPR) and other water recycling opportunities but is just the first step in the process of achieving the Study's stated objectives:

1. Identify opportunities to increase recycling of wastewater for IPR and Non-Potable Reuse (NPR)
2. Determine the extent recycling can reduce wastewater flows to the Point Loma Wastewater Treatment Plant
3. Determine implementation costs.

We appreciate the inclusion of the Metro TAC and Metro Commission/JPA as stakeholders in the Study process and San Diego's allowing the PAs to comment on each Technical Memorandum and including these comments and the PAs White Paper as appendices to the Report.

We accept San Diego's offer of our continued collaboration as stakeholders in the implementation process and acknowledge that additional investments will be needed to plan and develop the program to a level of detail that can be designed, permitted and constructed as outlined in the Implementation Checklist from the Report (attached). With this acceptance we request that the following items be addressed in the next year:

1. Finalize cost sharing framework
2. Move forward with all items listed on Finance Implementation Checklist
3. Identify water supply implications for the region and work with the County Water Authority.
4. Begin the Point Loma offloads starting with the Salt Creek Diversion to the South Bay Plant.



Ernest Ewin
Chairman, Metro JPA



Greg Humora
Chairman, MetroTAC

The Joint Powers Authority Proactively Addressing Regional Wastewater Issues

IMPLEMENTATION CHECKLIST: REGULATORY, INSTITUTIONAL, POLICY, FINANCE

Water Purification Demonstration Project/Permitting. The Water Purification Demonstration Project (Demonstration Project) and the San Vicente flow modeling are key steps of the public involvement and regulatory permitting processes to confirm the health and safety of the new water supply. The following summarizes these key implementation steps:

- Obtain Advanced Water Purification Facility water quality and San Vicente limnology model final results
- Provide on-going public involvement and community outreach
- Coordinate with CDPH and the Regional Water Quality Control Board on processes and permitting (whether through uniform criteria being developed by CDPH or project specific criteria)
- Promote advocacy by Stakeholder groups with CDPH and the Regional Water Quality Control Board

Mayor and City Council. Support from the Mayor and City Council is essential to implement such an important program. While the reuse program appears to offer substantial cost savings to ratepayers (compared to upgrading the Point Loma Plant), support from policymakers to advance the program will be needed. The following summarizes these key Mayor and City Council implementation steps:

- Obtain Independent Rates Oversight Committee support
- Obtain Natural Resources and Culture Committee approval.
- Obtain stakeholder advocacy support of the Study by the Metro JPA, Independent Rates Oversight Committee, environmental groups, and other interested parties.
- Obtain City Council approval.
- Coordinate implementation with broader water policy issues and programs

Metro JPA Approval. As partners in the Metro System, support from the Metro JPA is also essential to implement such an important program. Support from JPA policymakers is needed to advance the program. The following summarizes these key Metro JPA implementation steps:

- Finalize the cost sharing framework, as summarized below. This includes policy and legal issues, costs and consensus.
- Promote stakeholder advocacy in support of the Study by the City, Independent Rates Oversight Committee, environmental groups, and other interested parties.
- Obtain Policymaker approval to support the Study and the reuse program.

Financials. Fiscal responsibility is important for all parties. For Metropolitan Wastewater System ratepayers, there is an important choice required regarding whether to fund this water reuse plan or fund the alternative improvements at the Point Loma Plant. The following summarizes key financial implementation steps:

- Finalize cost share framework concepts and agreements
- Provide comparative financial analyses with other sources (if desired)
- Determine/develop policy on local resource program funding from SDCWA/MWD.
- Seek out and apply for grants.
- Develop of rate impacts
- Develop a detailed financing plan
- Provide funding and staff to move forward with the program implementation, including the activities needed for near-term and long-term projects



IMPLEMENTATION CHECKLIST: TECHNICAL

Technical/Other. Implementing the reuse plan will require technical evaluations and engineering. The following summarizes these key technical implementation steps:

- North City treatment. Determine the North City treatment approach (existing filters, feed source, recovery rates, improvements to the treatment processes upstream of the filters, the fate of the electro dialysis reversal unit's, and other technical design parameters.
- Non-potable reuse demands and wastewater flow confirmation. Continue to evaluate non-potable reuse demands and use trends; and wastewater flow generation. These totals will be important to finalize the size of indirect potable reuse projects.
- Point Loma permitting. Continue permitting coordination amongst Stakeholders as part of the Point Loma Plant 301h Modified Permit process.
- New facility siting. Develop detailed siting studies for new pump stations and treatment plants, including evaluation and confirmation of availability of the Harbor Drive and Camino del Rio North sites.
- Wastewater treatment pilot testing. Test treatment strategies and high rate systems to develop area-specific design values.
- New conveyance facility alignments. Perform alignment studies for new conveyance facilities.
- SV8 Diversion to South Bay. Update the SV8 Pump Station Predesign and Sweetwater River crossing concept (with possible evaluation of constructing solids handling facilities at the South Bay Plant in lieu of diverting to the Point Loma Plant). Coordinate efforts between the Recycled Water Study needs and the September 2011 Draft Wastewater Master Plan (or any updates) needs.
- South Bay Plant. Continue discussion and coordination on South Bay Plant issues, including on-going evaluations regarding whether to treat biosolids produced at the South Bay Plant at a dedicated facility instead of continuing to send it to the Point Loma Plant and the MBC for treatment.
- South Bay indirect potable reuse delivery. Perform detailed evaluation of the South Bay Plant expansion including pump station and delivery pipeline to Otay Lakes.
- Otay Lakes operation. Perform an Otay Lakes operational evaluation in relation to local runoff and indirect potable reuse operation to confirm flow rates and optimal project sizing. Develop a hydraulic model similar to those developed for the San Vicente Reservoir to determine seasonal hydraulic patterns within the Otay Lakes system.
- Joint Project Evaluation. Identify opportunities of joint projects, such as brine pipelines or indirect potable reuse delivery pipelines coordinated with other regional projects.
- Mission Gorge Plant Evaluations. Coordinate further discussion and evaluation on the merits of a joint plant with Padre Dam Municipal Water District in the Mission Gorge area (conceptualized in Alternative B3).
- Groundwater updates. Complete groundwater studies including evaluation of the San Diego Formation and San Diego River system for possible inclusion into future master planning efforts. Update the status of other County groundwater studies including San Pasqual and Padre Dam Municipal Water District's studies.
- Waste stream recovery. Evaluate waste stream efficiency and recovery analysis to evaluate ways to further minimize waste streams.



- San Vicente regulatory limits and operational coordination. Perform San Vicente analysis to evaluate maximum potential indirect potable reuse. If it is limited, determine options such as further evaluation of the San Diego formation or integration with other reservoirs. Coordinate reuse operational activities with other San Vicente operations after the dam raise is complete.
- Regulatory update on minimum reservoir capacities. Check assumptions on smaller sized reservoirs (Lakes Murray and Miramar) once indirect potable reuse reservoir augmentation regulations are finalized.
- SDCWA Coordination. Coordinate with SDCWA on their Master Plan (currently underway), broader water policy support at the state level, and possible regional collaboration involving funding.
- Peak Wet Weather Flow strategies. Continue to evaluate fail-safe disposal strategies under wet weather conditions, including equalization, live stream discharge, and CEPT-secondary effluent blending at the Point Loma Plant.



APPENDIX M: CITY COUNCIL RESOLUTION



This page intentionally left blank.

RESOLUTION NUMBER R- 307585

DATE OF FINAL PASSAGE JUL 19 2012

A RESOLUTION OF THE COUNCIL OF THE CITY OF SAN DIEGO AUTHORIZING RECEIPT OF THE RECYCLED WATER STUDY FINAL DRAFT REPORT.

WHEREAS, in 2010, the United States Environmental Protection Agency [USEPA] granted the City of San Diego a 301(h) modification to its National Pollutant Discharge Elimination System Permit [Permit], which allows the City to continue to discharge chemically-enhanced primary treated water from the Point Loma Wastewater Treatment Plant [Point Loma]; and

WHEREAS, on January 27, 2009, the City Council adopted Resolution R-304617 authorizing and execution of a cooperative agreement with San Diego Coastkeeper and San Diego Chapter of the Surfrider Foundation to execute a Recycled Water Study; and

WHEREAS, during the Permit renewal application process, San Diego Coastkeeper and the San Diego Chapter of Surfrider Foundation entered into a Cooperative Agreement with the City to conduct a Recycled Water Study, and the City's responsibility is to complete the Study within two years of the Permit's effective date of August 1, 2010; NOW, THEREFORE,

BE IT RESOLVED, by the Council of the City of San Diego, that the Mayor, or his designee, is authorized to receive the Recycled Water Study Draft Report as a fulfillment of the elements outlined in Resolution R-304617 adopted on January 27, 2009.

BE IT FURTHER RESOLVED, that the Mayor, or his designee, is authorized to receive the Recycled Water Study Final Draft Report as a fulfillment of the elements outlined in the Cooperative Agreement.

BE IT FURTHER RESOLVED, that the Mayor, or his designee, is authorized to refer a prioritization of the key implementation steps contained in Section 8 of the Recycled Water Study Draft Report to the Natural Resources & Culture Committee for its consideration.

APPROVED: JANI GOLDSMITH, City Attorney

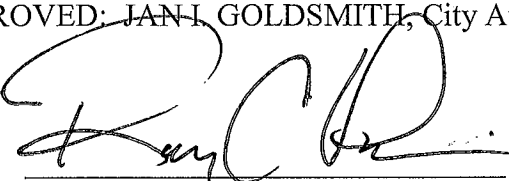
By 
Raymond C. Palmucci
Deputy City Attorney

RCP:cfq
6/07/2012
Or.Dept:Water
Doc. No.: 369989

I hereby certify that the foregoing Resolution was passed by the Council of the City of San Diego, at this meeting of July 17, 2012

ELIZABETH S. MALAND
City Clerk

By 
Deputy City Clerk

Approved: 7-19-12
(date)

JERRY SANDERS, Mayor

Vetoed: _____
(date)

JERRY SANDERS, Mayor



Prepared by

