

APPENDIX F

- Truck Counts Data

	NB				SB				EB				WB				INTERVAL TOTALS
	Main St.				Main St.				Schley St.				Schley St.				
	Left	Thru	Right	HV	Left	Thru	Right	HV	Left	Thru	Right	HV	Left	Thru	Right	HV	
06:00 AM		1													1		
06:15 AM														1			
06:30 AM						1											
06:45 AM																	
07:00 AM		1									1						
07:15 AM		1															
07:30 AM		1			1				1					1			
07:45 AM			1			1											
08:00 AM		1				1											
08:15 AM		2															
08:30 AM		1											1	1			
08:45 AM																	
09:00 AM		2															
09:15 AM																	
09:30 AM					1		1										
09:45 AM	1	1				2	1								1		
Sum	1	11	1	0	2	5	2	0	1	0	1	0	1	3	2	0	0
02:00 PM																	
02:15 PM						3											
02:30 PM						1											
02:45 PM																	
03:00 PM		1															
03:15 PM															1		
03:30 PM		1															
03:45 PM																	
04:00 PM					1	1				1							
04:15 PM					1												
04:30 PM													1				
04:45 PM																	
05:00 PM																	
05:15 PM																	
05:30 PM																	
05:45 PM																	
Sum	0	2	0	0	2	5	0	0	0	1	0	0	1	0	1	0	0
	1	13	1	0	4	10	2	0	1	1	1	0	2	3	3	0	
	15				16				3				8				

	NB				SB				EB				WB				INTERVAL TOTALS
	Harbor Dr				Harbor Dr				Schley St.				Schley St.				
	Left	Thru	Right	HV	Left	Thru	Right	HV	Left	Thru	Right	HV	Left	Thru	Right	HV	
06:00 AM						1											
06:15 AM											1						
06:30 AM			1			2											
06:45 AM			3			1											
07:00 AM			2														
07:15 AM			2			1											
07:30 AM			3	1		1									1		
07:45 AM			1			1											
08:00 AM			3			2											
08:15 AM						5											
08:30 AM			3			2											
08:45 AM				1													
09:00 AM			2			2											
09:15 AM			3														
09:30 AM			3										1				
09:45 AM			3			1					2						
Sum	0	29	2	0	0	19	0	0	0	0	3	0	1	0	1	0	
02:00 PM		1				1											
02:15 PM						1											
02:30 PM						1											
02:45 PM																	
03:00 PM						2											
03:15 PM																	
03:30 PM																	
03:45 PM						2											
04:00 PM			1			2											
04:15 PM																	
04:30 PM																	
04:45 PM							1										
05:00 PM																	
05:15 PM																	
05:30 PM																	
05:45 PM																	
Sum																0	
	0	29	2	0	0	19	0	0	0	0	3	0	1	0	1	0	
		31				19				3			2				

	NB				SB				EB				WB				INTERVAL TOTALS
	Harbor Dr				Harbor Dr				Sicard St.				None				
	Left	Thru	Right	HV	Left	Thru	Right	HV	Left	Thru	Right	HV	Left	Thru	Right	HV	
06:00 AM																	
06:15 AM		1															
06:30 AM		3				1											
06:45 AM		2				3											
07:00 AM		4															
07:15 AM		1				2											
07:30 AM		2				1											
07:45 AM		2				4											
08:00 AM		3				5											
08:15 AM		1				3											
08:30 AM		8				2											
08:45 AM		2				2											
09:00 AM		4				3											
09:15 AM		2															
09:30 AM		5				2											
09:45 AM		4				2											
Sum	0	44	0	0	0	30	0	0	0	0	0	0	0	0	0	0	0
<hr/>																	
02:00 PM		4				2					1						
02:15 PM						2											
02:30 PM		2				1											
02:45 PM																	
03:00 PM																	
03:15 PM		1				2											
03:30 PM						2											
03:45 PM						1											
04:00 PM						1											
04:15 PM						2											
04:30 PM						1											
04:45 PM						2											
05:00 PM						1											
05:15 PM																	
05:30 PM																	
05:45 PM																	
Sum	0	7	0	0	0	17	0	0	0	0	1	0	0	0	0	0	0
<hr/>																	
	0	51	0	0	0	47	0	0	0	0	1	0	0	0	0	0	0

51

47

1

0

3-Axle Trucks Total Count

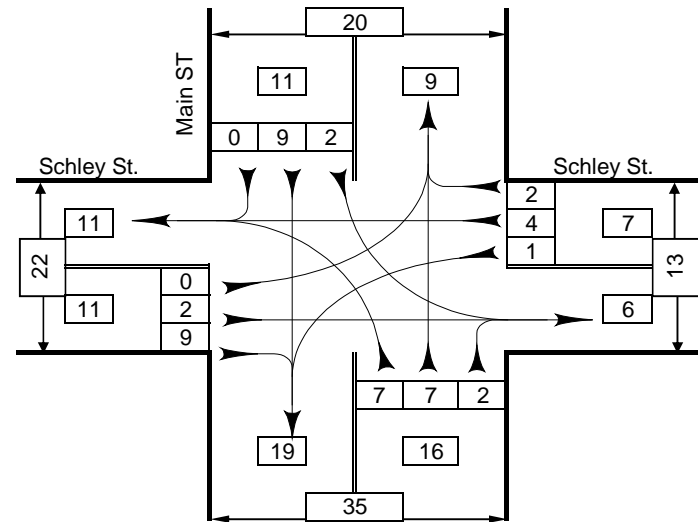
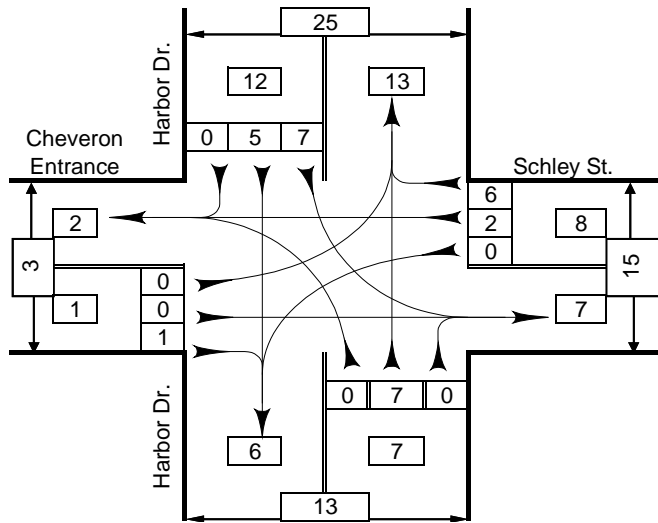
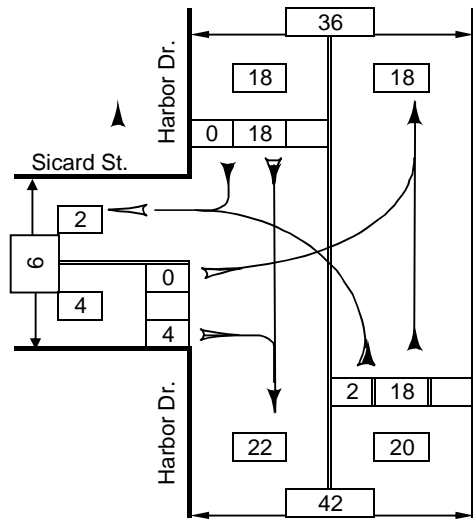

3-Axle Trucks AM Count

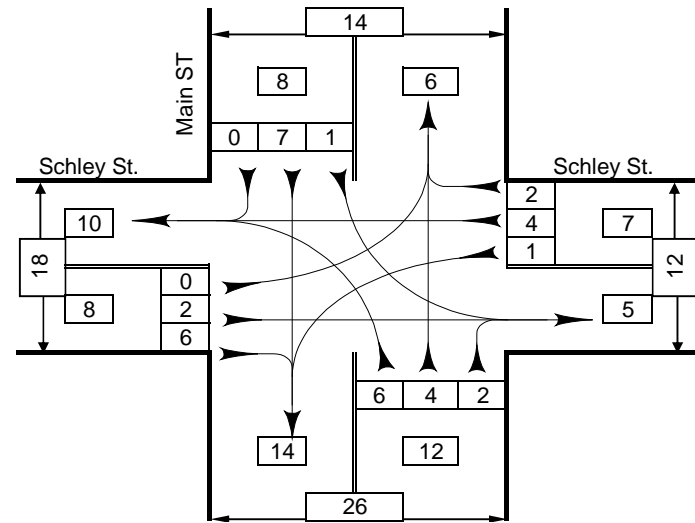
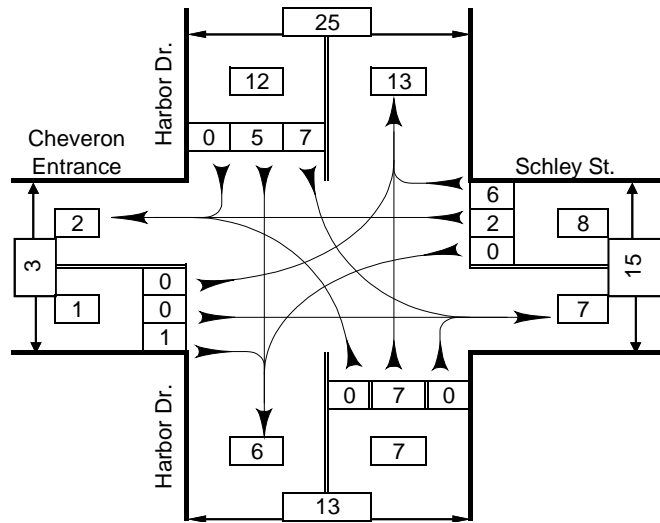
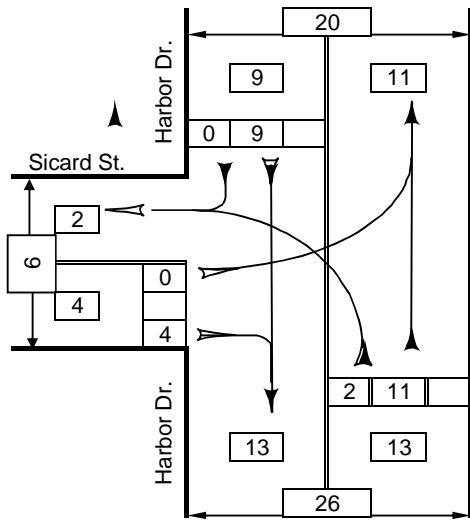

4-Axle Trucks Total Count

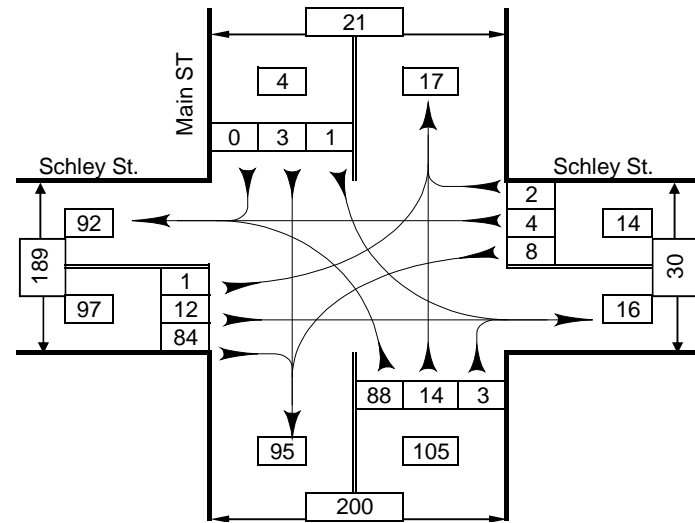
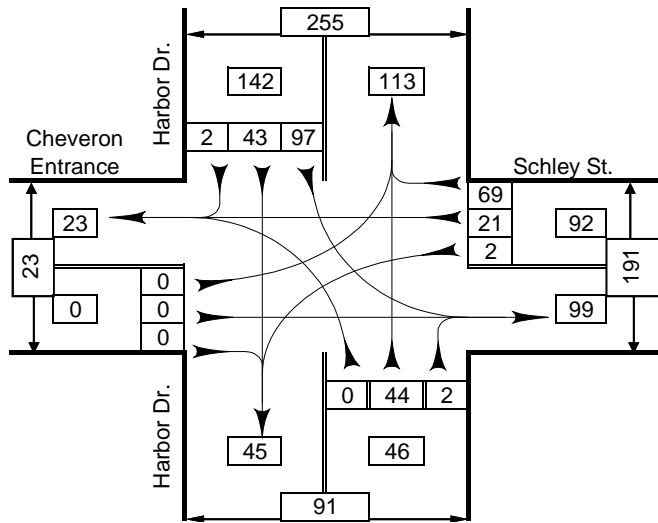
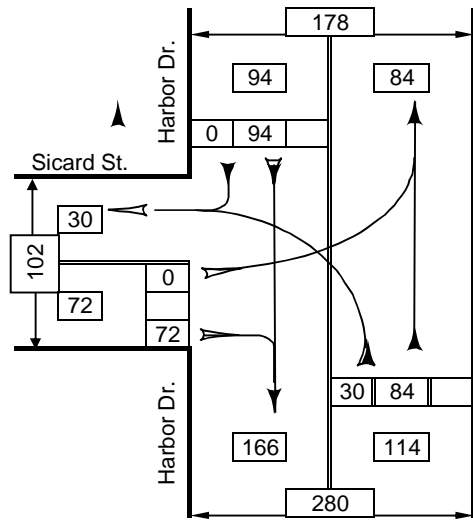

4-Axle Trucks PM Count
 PM Peak 4:30

