

City of San Diego

CONTRACTOR'S NAME: _____
ADDRESS: _____
TELEPHONE NO.: _____ FAX NO.: _____
CITY CONTACT: Damian Singleton, Contract Specialist, Email: Dsingleton@sandiego.gov
Phone No. (619) 533-3482, Fax No. (619) 533-3633
DLi/BDoringo/egz

CONTRACT DOCUMENTS



FOR

25TH STREET RENAISSANCE PROJECT

VOLUME 1 OF 2

BID NO.: _____ K-14-5524-DBB-3
SAP NO. (WBS/IO/CC): _____ S-00985, B-12016
CLIENT DEPARTMENT: _____ 2113, 2013
COUNCIL DISTRICT: _____ 3
PROJECT TYPE: _____ IG, KB
FEDERAL AID PROJECT NO.: _____ RPSTPLE 5004(176)

THIS CONTRACT IS SUBJECT TO THE FOLLOWING:

- THE CITY'S SUBCONTRACTING PARTICIPATION REQUIREMENTS FOR SLBE PROGRAM.
- PREVAILING WAGE RATES APPLY: STATE FEDERAL

BID DUE DATE:

**2:00 PM
OCTOBER 31, 2013
CITY OF SAN DIEGO
PUBLIC WORKS CONTRACTING GROUP
1010 SECOND AVENUE, SUITE 1400, MS 614C
SAN DIEGO, CA 92101**

ENGINEER OF WORK

The engineering Specifications and Special Provisions contained herein have been prepared by or under the direction of the following Registered Engineer:

Gerald L. Michael

9/19/2013

Seal:

1) Registered Engineer

Date



Brad Johnson

9/19/13

Seal

2) For City Engineer

Date



TABLE OF CONTENTS

1. NOTICE INVITING BIDS.....	4
2. CONTRACT FORMS AGREEMENT.....	17
3. CONTRACT/AGREEMENTS ATTACHMENTS:	
1. Performance Bond and Labor and Materialmen’s Bond.....	21
2. Drug-Free Workplace.....	23
3. American with Disabilities Act (ADA) Compliance Certification	24
4. Contractor Standards - Pledge of Compliance Certificate.....	25
5. Affidavit of Disposal Certificate	26
6. Materials and Workmanship Compliance	27
7. Notice of Materials to Be Used	28
4. SUPPLEMENTARY SPECIAL PROVISIONS	29
5. SUPPLEMENTARY SPECIAL PROVISIONS - APPENDICES:	
A. Notice of Exemption.....	50
B. Fire Hydrant Meter Program	53
C. Materials Typically Accepted by Certificate of Compliance	67
D. Sample City Invoice	69
E. Location Map.....	71
F. Storm Water Prevention Pollution Plan.....	73
G. Hydrostatic Discharge Form.....	75
H. Adjacent Project	77

CITY OF SAN DIEGO, CALIFORNIA

NOTICE INVITING BIDS

1. **RECEIPT AND OPENING OF BIDS:** Bids will be received at the Public Works Contracting Group at the location, time, and date shown on the cover of these specifications for performing work on **25th Street Renaissance Project** (Project).
2. **DESCRIPTION OF WORK:** The Work involves furnishing all labor, materials, equipment, services, and other incidental works and appurtenances for the construction of the Project as described below:

The 25th Street Renaissance Project will provide traffic calming improvements to increase pedestrian safety, additional street parking, as well as streetscape improvements to enhance the aesthetics of the corridor. Additionally, the project includes replacement of existing water main.

2.1. The Work shall be performed in accordance with:

2.1.1. This Notice Inviting Bids and Plans numbered **36515-1-D** through **36515-29-D** and **36515-T1-D** through **36515-T12-D**, inclusive.

3. **EQUAL OPPORTUNITY.**

3.1 To The WHITEBOOK, Chapter 10, Sections D and E, DELETE in their entirety and SUBSTITUTE with the following:

D. CITY'S EQUAL OPPORTUNITY COMMITMENT.

1. Nondiscrimination in Contracting Ordinance.

1. The Contractor, Subcontractors and Suppliers shall comply with requirements of the City's Nondiscrimination in Contracting Ordinance, San Diego Municipal Code §§22.3501 through 22.3517.

The Contractor shall not discriminate on the basis of race, gender, religion, national origin, ethnicity, sexual orientation, age, or disability in the solicitation, selection, hiring, or treatment of subcontractors, vendors, or suppliers. The Contractor shall provide equal opportunity for subcontractors to participate in subcontracting opportunities. The Contractor understands and agrees that violation of this clause shall be considered a material breach of the contract and may result in contract termination, debarment, or other sanctions.

The Contractor shall include the foregoing clause in all contracts between the Contractor and Subcontractors and Suppliers.

2. Disclosure of Discrimination Complaints. As part of its Bid or Proposal, the Bidder shall provide to the City a list of all instances within the past 10 years where a complaint was filed or pending against Bidder in a legal or administrative proceeding alleging that

Bidder discriminated against its employees, subcontractors, vendors, or suppliers, and a description of the status or resolution of that complaint, including any remedial action taken.

3. Upon the City's request, the Contractor agrees to provide to the City, within 60 days, a truthful and complete list of the names of all Subcontractors and Suppliers that the Contractor has used in the past 5 years on any of its contracts that were undertaken within San Diego County, including the total dollar amount paid by the Contractor for each subcontract or supply contract.
4. The Contractor further agrees to fully cooperate in any investigation conducted by the City pursuant to the City's Nondiscrimination in Contracting Ordinance, Municipal Code §§22.3501 through 22.3517. The Contractor understands and agrees that violation of this clause shall be considered a material breach of the Contract and may result in remedies being ordered against the Contractor up to and including contract termination, debarment and other sanctions for violation of the provisions of the Nondiscrimination in Contracting Ordinance. The Contractor further understands and agrees that the procedures, remedies and sanctions provided for in the Nondiscrimination in Contracting Ordinance apply only to violations of the Ordinance.

E. EQUAL EMPLOYMENT OPPORTUNITY OUTREACH PROGRAM.

1. The Contractor, Subcontractors and Suppliers shall comply with the City's Equal Employment Opportunity Outreach Program, San Diego Municipal Code §§22.2701 through 22.2707.

The Contractor shall not discriminate against any employee or applicant for employment on any basis prohibited by law. Contractor shall provide equal opportunity in all employment practices. Prime Contractor shall ensure their subcontractors comply with this program. Nothing in this section shall be interpreted to hold a prime contractor liable for any discriminatory practice of its subcontractors.

The Contractor shall include the foregoing clause in all contracts between the Contractor and Subcontractors and Suppliers.

2. If the Contract is competitively solicited, the selected Bidder shall submit a Work Force Report (Form BB05), within 10 Working Days after receipt by the Bidder of Contract forms to the City for approval as specified in the Notice of Intent to Award letter from the City.
3. If a Work Force Report is submitted, and the City determines there are under-representations when compared to County Labor Force Availability data, the selected Bidder shall submit an Equal Employment Opportunity Plan.
4. If the selected Bidder submits an Equal Employment Opportunity Plan, it shall include the following assurances:

1. The Contractor shall maintain a working environment free of discrimination, harassment, intimidation and coercion at all sites and in all facilities at which the Contractor's employees are assigned to work.
2. The Contractor reviews its EEO Policy, at least annually, with all on-site supervisors involved in employment decisions.
3. The Contractor disseminates and reviews its EEO Policy with all employees at least once a year, posts the policy statement and EEO posters on all company bulletin boards and job sites, and documents every dissemination, review and posting with a written record to identify the time, place, employees present, subject matter, and disposition of meetings.
4. The Contractor reviews, at least annually, all supervisors' adherence to and performance under the EEO Policy and maintains written documentation of these reviews.
5. The Contractor discusses its EEO Policy Statement with subcontractors with whom it anticipates doing business, includes the EEO Policy Statement in its subcontracts, and provides such documentation to the City upon request.
6. The Contractor documents and maintains a record of all bid solicitations and outreach efforts to and from subcontractors, contractor associations and other business associations.
7. The Contractor disseminates its EEO Policy externally through various media, including the media of people of color and women, in advertisements to recruit, maintains files documenting these efforts, and provides copies of these advertisements to the City upon request.
8. The Contractor disseminates its EEO Policy to union and community organizations.
9. The Contractor provides immediate written notification to the City when any union referral process has impeded the Contractor's efforts to maintain its EEO Policy.
10. The Contractor maintains a current list of recruitment sources, including those outreaching to people of color and women, and provides written notification of employment opportunities to these recruitment sources with a record of the organizations' responses.
11. The Contractor maintains a current file of names, addresses and phone numbers of each walk-in applicant, including people of color and women, and referrals from unions, recruitment sources, or community organizations with a description of the employment action taken.
12. The Contractor encourages all present employees, including people of color and women employees, to recruit others.

13. The Contractor maintains all employment selection process information with records of all tests and other selection criteria.
14. The Contractor develops and maintains documentation for on-the-job training opportunities, participates in training programs, or both for all of its employees, including people of color and women, and establishes apprenticeship, trainee, and upgrade programs relevant to the Contractor's employment needs.
15. The Contractor conducts, at least annually, an inventory and evaluation of all employees for promotional opportunities and encourages all employees to seek and prepare appropriately for such opportunities.
16. The Contractor ensures the company's working environment and activities are non-segregated except for providing separate or single-user toilets and necessary changing facilities to assure privacy between the sexes.

4. SUBCONTRACTING PARTICIPATION PERCENTAGES.

4.1. The City has incorporated **mandatory** SLBE-ELBE subcontractor participation percentages to enhance competition and maximize subcontracting opportunities. For the purpose of achieving the mandatory subcontractor participation percentages, a recommended breakdown of the SLBE and ELBE subcontractor participation percentages based upon certified SLBE and ELBE firms has also been provided to achieve the mandatory subcontractor participation percentages:

1. SLBE participation	10.3 %
2. ELBE participation	23.1 %
3. Total mandatory participation	33.4 %

4.2. The Bidders are strongly encouraged to attend the Pre-Bid Meeting to better understand the Good Faith Effort requirements of this contract. See the City's document titled "SLBE Program, Instructions For Bidders Completing The Good Faith Effort Submittal" available at: <http://www.sandiego.gov/eoc/>.

4.3. The Bid will be declared non-responsive if the Bidder fails the following mandatory conditions:

4.3.1. Bidder's inclusion of SLBE-ELBE certified subcontractors at the overall mandatory participation percentage identified in this document; OR.

4.3.2. Bidder's submission of Good Faith Effort documentation demonstrating the Bidder made a good faith effort to outreach to and include SLBE-ELBE Subcontractors required in this document within 3 Working Day of the Bid opening if the overall mandatory participation percentage is not met.

5. PRE-BID MEETING:

5.1. There will be a Pre-Bid Meeting to discuss the scope of the Project, bidding requirements, pre-qualification process, and Equal Opportunity Contracting Program

requirements and reporting procedures in the Public Works Contracting Group, Conference Room at 1010 Second Avenue, Suite 1400, San Diego, CA 92101 **at 10:00 AM, on OCTOBER 10, 2013.**

- 5.2. All potential bidders are encouraged to attend.
- 5.3. To request a copy of the agenda on an alternative format, or to request a sign language or oral interpreter for this meeting, call the Public Works Contracting Group at (619) 533-3450 at least 5 Working Days prior to the Pre-Bid Meeting to ensure availability.
6. **CONTRACTOR REGISTRATION AND ELECTRONIC REPORTING SYSTEM:**
 - 6.1. **Prior** to the Award of the Contract or each Task Order, you and your Subcontractors and Suppliers **must** register with Prism®, the City’s web-based contract compliance portal at:
<https://pro.prismcompliance.com/default.aspx>.
 - 6.2. The City may not award the contract until registration of all subcontractors and suppliers is complete. In the event this requirement is not met within the time frame specified in the Notice of Intent to Award letter, the City reserves the right to rescind the Notice of Award / Intent to Award and to make the award to the next responsive and responsible bidder / proposer.
7. **CONSTRUCTION COST:** The City’s estimated construction cost for this contract is **\$1,960,000.**
8. **LOCATION OF WORK:** The location of the Work is as follows:
25th Street between F Street and Russ Boulevard.
9. **CONTRACT TIME:** The Contract Time for completion of the Work shall be **140 Working Days.**
10. **CONTRACTOR'S LICENSE CLASSIFICATION:** In accordance with the provisions of California Law, the Contractor shall possess valid appropriate license(s) at the time that the Bid is submitted. Failure to possess the specified license(s) shall render the Bid as **non-responsive** and shall act as a bar to award of the Contract to any Bidder not possessing required license(s) at the time of Bid.
 - 10.1. The City has determined the following licensing classification(s) for this contract:
 - CLASS A
11. **JOINT VENTURE CONTRACTORS:** Provide a copy of the Joint Venture agreement and the Joint Venture license to the City within 10 Working Days after receiving the Contract forms. See 2-1.1.2, “Joint Venture Contractors” in The WHITEBOOK for details.
12. **WAGE RATES:** Prevailing wage rates apply to this contract.
 - 12.1. **STATE REQUIREMENTS FOR CONTRACTS SUBJECT TO STATE PREVAILING WAGE REQUIREMENTS.**

- 12.1.1** In accordance with the provisions of California Labor Code Sections 1770, et seq. as amended, the Director of the Department of Industrial Relations has determined the general prevailing rate of per diem wages in accordance with the standards set forth in such Sections for the locality in which the Work is to be performed. Copies of the prevailing rate of per diem wages may be found at http://www.dir.ca.gov/dlsr/statistics_research.html. The Contractor shall post a copy of the above determination of the prevailing rate of per diem wages at each job site and shall make them available to any interested party on request.
- 12.1.2.** Pursuant to Sections 1720 et seq., and 1770 et seq., of the California Labor Code the Contractor any Subcontractor shall pay not less than said specified rates determined by the Director of the California Department of Industrial Relations to all workmen employed by them in the execution of the Work.
- 12.1.3.** The wage rates determined by the Director of Industrial Relations and published in the Department of Transportation publication entitled, "General Prevailing Wage Rates", refer to expiration dates. If the published wage rate does not refer to a predetermined wage rate to be paid after the expiration date, said published rate of wage shall be in effect for the life of this contract. If the published wage rate refers to a predetermined wage rate to become effective upon expiration of the published wage rate and the predetermined wage rate is on file with the Department of Industrial Relations, such predetermined wage rate shall become effective on the date following the expiration date and shall apply to this contract in the same manner as if it had been published in said publication. If the predetermined wage rate refers to one or more additional expiration dates with additional predetermined wage rates, which expiration dates occur during the life of this contract, each successive predetermined wage rate shall apply to this contract on the date following the expiration date of the previous wage rate. If the last of such predetermined wage rates expires during the life of this contract, such wage rate shall apply to the balance of the contract.
- 12.1.4.** The successful bidder intending to use a craft or classification not shown on the prevailing rate determinations may be required to pay the rate of the craft or classification most closely related to it.

13. INSURANCE REQUIREMENTS:

- 13.1.** All certificates of insurance and endorsements required by the contract are to be provided upon issuance of the City's Notice of Intent to Award letter.
- 13.2.** Refer to sections 7-3, "LIABILITY INSURANCE", and 7-4, "WORKERS' COMPENSATION INSURANCE" of the Supplementary Special Provisions (SSP) for the insurance requirements which must be met.

14. PREQUALIFICATION OF CONTRACTORS:

- 14.1.** Contractors submitting Bid must be pre-qualified for the total amount proposed, inclusive of all alternate items prior to the date of submittal. Bids from contractors who have not been pre-qualified as applicable and Bids that exceed the maximum dollar amount at

which contractors are pre-qualified will be deemed **non-responsive** and ineligible for award. Complete information and prequalification questionnaires are available at:

<http://www.sandiego.gov/cip/bidopps/prequalification.shtml>

14.2. The completed questionnaire, financial statement, and bond letter or a copy of the contractor’s SLBE-ELBE certification and bond letter, must be submitted no later than 2 weeks prior to the bid opening to the Public Works Contracting Group, Prequalification Program, 1010 Second Avenue, Suite 1400, San Diego, CA 92101. For additional information or the answer to questions about the prequalification program, contact David Stucky at 619-533-3474 or dstucky@sandiego.gov.

15. REFERENCE STANDARDS: Except as otherwise noted or specified, the Work shall be completed in accordance with the following standards:

Title	Edition	Document Number
Standard Specifications for Public Works Construction (“The GREENBOOK”)	2012	PITS070112-01
City of San Diego Standard Specifications for Public Works Construction (“The WHITEBOOK”)*	2012	PITS070112-02
City of San Diego Standard Drawings*	2012	PITS070112-03
Caltrans Standard Specifications	2010	PITS070112-04
Caltrans Standard Plans	2010	PITS070112-05
California MUTCD	2012	PITS070112-06
City Standard Drawings - Updates Approved For Use (when specified)*	Varies	Varies
Standard Federal Equal Employment Opportunity Construction Contract Specifications and the Equal Opportunity Clause Dated 09-11-84	1984	769023
NOTE: Available online under Engineering Documents and References at: http://www.sandiego.gov/publicworks/edocref/index.shtml		

16. CITY'S RESPONSES AND ADDENDA: The City at its option, may respond to any or all questions submitted in writing, via letter, or FAX in the form of an addendum. No oral comment shall be of any force or effect with respect to this solicitation. The changes to the Contract Documents through addendum are made effective as though originally issued with the Bid. The Bidders shall acknowledge the receipt of Addenda on the form provided for this purpose in the Bid.

17. CITY'S RIGHTS RESERVED: The City reserves the right to cancel the Notice Inviting Bids at any time, and further reserves the right to reject submitted Bids, without giving any reason for such action, at its sole discretion and without liability. Costs incurred by the Bidder(s) as a result of preparing Bids under the Notice Inviting Bids shall be the sole responsibility of each bidder. The Notice Inviting Bids creates or imposes no obligation upon the City to enter a contract.

18. CONTRACT PRICING FORMAT: This solicitation is for a Lump Sum contract with Unit Price provisions as set forth in the Bid Proposal Form(s), Volume 2.

19. SUBMITTAL OF “OR EQUAL” ITEMS: See Section 4-1.6, “Trade Names or Equals” in The WHITEBOOK and as amended in the SSP.

20. AWARD PROCESS:

- 20.1.** The Award of this contract is contingent upon the Contractor's compliance with all conditions precedent to Award.
- 20.2.** Upon acceptance of a Bid, the City will prepare contract documents for execution within approximately 21 days of the date of the Bid opening and award the Contract approximately within 7 days of receipt of properly executed Contract, bonds, and insurance documents.
- 20.3.** This contract will be deemed executed, and effective, only upon the signing of the Contract by the Mayor or designee of the City.

21. SUBCONTRACT LIMITATIONS: The Bidder's attention is directed to Standard Specifications for Public Works Construction, Section 2-3, "SUBCONTRACTS" in The WHITEBOOK and as amended in the SSP which requires the Contractor to self perform the amount therein stipulated. Failure to comply with these requirements may render the Bid **non-responsive** and ineligible for award.

22. AVAILABILITY OF PLANS AND SPECIFICATIONS: Contract Documents may be obtained by visiting the City's website: <http://www.sandiego.gov/cip/>. Plans and Specifications for this contract are also available for review in the office of the City Clerk or Public Works Contracting Group.

23. QUESTIONS:

- 23.1.** The Director (or designee), of the Public Works Department is the officer responsible for opening, examining, and evaluating the competitive Bids submitted to the City for the acquisition, construction and completion of any public improvement except when otherwise set forth in these documents. All questions related to this procurement action shall be addressed to the Public Works Contracting Group, Attention Contract Specialist, 1010 Second Avenue, Suite 1400, San Diego, California, 92101, and Telephone No. (619) 533-3450.
- 23.2.** Questions received less than 14 days prior to the date for opening of Bids may not be answered.
- 23.3.** Interpretations or clarifications considered necessary by the City in response to such questions will be issued by Addenda which will be uploaded to the City's online bidding service.
- 23.4.** Only questions answered by formal written addenda will be binding. Oral and other interpretations or clarifications will be without legal effect. It is the Bidder's responsibility to become informed of any Addenda that have been issued and to include all such information in its Bid.

24. ELIGIBLE BIDDERS: No person, firm, or corporation shall be allowed to make, file, or be interested in **more** than one (1) Bid for the same work unless alternate Bids are called for. A person, firm or corporation who has submitted a sub-proposal to a Bidder, or who has quoted prices on materials to a Bidder, is not hereby disqualified from submitting a sub-proposal or quoting prices to other Bidders or from submitting a Bid in its own behalf. Any Bidder who submits more than one bid will result in the rejection of all bids submitted.

- 25. SAN DIEGO BUSINESS TAX CERTIFICATE:** The Contractor and Subcontractors, not already having a City of San Diego Business Tax Certificate for the work contemplated shall secure the appropriate certificate from the City Treasurer, Civic Center Plaza, first floor and submit to the Contract Specialist upon request or as specified in the Contract Documents. Tax Identification numbers for both the Bidder and the listed Subcontractors must be submitted on the City provided forms with the Notice Inviting Bids and Contract forms.
- 26. PROPOSAL FORMS:** Bid shall be made only upon the Bidding Documents i.e., Proposal form attached to and forming a part of the specifications. The signature of each person signing shall be in longhand.
- 26.1.** Bidder shall complete and submit all pages in the "Bidding Document" Section (see Volume 2) as their Bid per the schedule given under "Required Documents Schedule," (see Volume 1). Bidder is requested to retain for their reference other portions of the Contract Documents that are not required to be submitted with the Bid. The entire specifications for the bid package do not need to be submitted with the bid.
- 26.2.** The City may require any Bidder to furnish a statement of experience, financial responsibility, technical ability, equipment, and references.
- 26.3.** Bids and certain other forms and documents as specified in the Volume 2 of 2 of the Contract Documents shall be enclosed in a sealed envelope and shall bear the title of the work and name of the Bidder and the appropriate State Contractors License designation which the Bidder holds.
- 26.4.** Bids may be withdrawn by the Bidder prior to, but not after, the time fixed for opening of Bids.
- 27. BIDDERS' GUARANTEE OF GOOD FAITH (BID SECURITY):**
- 27.1.** With the exception of the contracts valued \$5,000 or less, JOC and Design-Build contracts, and contracts subject to the Small and Local Business Program of \$250,000 or less e.g., ELBE contracts, each Bidder shall accompany its Bid with either a cashier's check upon some responsible bank, or a check upon such bank properly certified or an approved corporate surety bond payable to the City of San Diego, for an amount of not less than 10% of the aggregate sum of the Bid, which check or bond, and the monies represented thereby shall be held by the City as a guarantee that the Bidder, if awarded the contract, will in good faith enter into such contract and furnish the required final bonds.
- 27.2.** The Bidder agrees that in case of Bidder's refusal or failure to execute this contract and give required final bonds, the money represented by a cashier's or certified check shall remain the property of the City, and if the Bidder shall fail to execute this contract, the Surety agrees that it will pay to the City damages which the City may suffer by reason of such failure, not exceeding the sum of 10% of the amount of the Bid.
- 27.3.** A Bid received without the specified bid security will be rejected as being **non-responsive**.
- 28. AWARD OF CONTRACT OR REJECTION OF BIDS:**
- 28.1.** This contract may be awarded to the lowest responsible and reliable Bidder.

- 28.2. Bidders shall complete the entire Bid schedule (also referred to as “schedule of prices” or Proposal form). Incomplete price schedules will be rejected as being non-responsive.
- 28.3. The City reserves the right to reject any or all Bids, and to waive any informality or technicality in Bids received and any requirements of these specifications as to bidding procedure.
- 28.4. Bidders will not be released on account of their errors of judgment. Bidders may be released only upon receipt by the City from the Bidder within 3 Working Days, excluding Saturdays, Sundays, and state holidays, after the opening of Bids, of written notice which includes proof of honest, credible, clerical error of material nature, free from fraud or fraudulent intent, and of evidence that reasonable care was observed in the preparation of the Bid.
- 28.5. A non-selected Bidder may protest award of the Contract to the selected Bidder by submitting a written “Notice of Intent to Protest” including supporting documentation which shall be received by Public Works Contracting Group no later than 10 days after the City’s announcement of the selected Bidder or no later than 10 days from the date that the City issues notice of designation of a Bidder as non-responsive in accordance with San Diego Municipal Code Chapter 2, § 22.3029, “Protests of Contract Award.”
- 28.6. The City of San Diego will not discriminate with regard to race, religious creed, color, national origin, ancestry, physical handicap, marital status, sex or age, in the award of contracts.
- 28.7. Each Bid package properly executed as required by these specifications shall constitute a firm offer, which may be accepted by the City within the time specified in the Proposal.
- 28.8. The City reserves the right to evaluate all Bids and determine the lowest Bidder on the basis of any proposed alternates, additive items or options, at its discretion that will be disclosed in the Volume 2 of 2.

29. BID RESULTS:

- 29.1. The Bid opening by the City shall constitute the public announcement of the Apparent Low Bidder. In the event that the Apparent Low Bidder is subsequently deemed non-responsive or non-responsible, a public announcement will be posted in the City’s web page: <http://www.sandiego.gov/cip/index.shtml>, with the name of the newly designated Apparent Low Bidder.
- 29.2. To obtain Bid results, either attend Bid opening, review the results on the City’s web site, or provide a self-addressed, stamped envelope, referencing Bid number, and Bid tabulation will be mailed to you upon verification of extensions. Bid results cannot be given over the telephone.

30. THE CONTRACT:

- 30.1. The Bidder to whom award is made shall execute a written contract with the City of San Diego and furnish good and approved bonds and insurance certificates specified by the City within 14 days after receipt by Bidder of a form of contract for execution unless an extension of time is granted to the Bidder in writing.

- 30.2.** If the Bidder takes longer than 14 days to fulfill these requirements, then the additional time taken shall be added to the Bid guarantee. The Contract shall be made in the form adopted by the City, which includes the provision that no claim or suit whatsoever shall be made or brought by Contractor against any officer, agent, or employee of the City for or on account of anything done or omitted to be done in connection with this contract, nor shall any such officer, agent, or employee be liable hereunder.
- 30.3.** If the Bidder to whom the award is made fails to enter into the contract as herein provided, the award may be annulled and the Bidder's Guarantee of Good Faith will be subject to forfeiture. An award may be made to the next lowest responsible and reliable Bidder who shall fulfill every stipulation embraced herein as if it were the party to whom the first award was made.
- 30.4.** Pursuant to the San Diego City Charter section 94, the City may only award a public works contract to the lowest responsible and reliable Bidder. The City will require the Apparent Low Bidder to (i) submit information to determine the Bidder's responsibility and reliability, (ii) execute the Contract in form provided by the City, and (iii) furnish good and approved bonds and insurance certificates specified by the City within 14 Days, unless otherwise approved by the City, in writing after the Bidder receives notification from the City, designating the Bidder as the Apparent Low Bidder and formally requesting the above mentioned items.
- 30.5.** The award of the Contract is contingent upon the satisfactory completion of the above mentioned items and becomes effective upon the signing of the Contract by the Mayor or designee. If the Apparent Low Bidder does not execute the Contract or submit required documents and information, the City may award the Contract to the next lowest responsible and reliable Bidder who shall fulfill every condition precedent to award. A corporation designated as the Apparent Low Bidder shall furnish evidence of its corporate existence and evidence that the officer signing the Contract and bond for the corporation is duly authorized to do so.
- 31. EXAMINATION OF PLANS, SPECIFICATIONS, AND SITE OF WORK:** The Bidder shall examine carefully the Project Site, the Plans and Specifications, other materials as described in the Special Provisions, Section 2-7, and the proposal forms (e.g., Bidding Documents). The submission of a Bid shall be conclusive evidence that the Bidder has investigated and is satisfied as to the conditions to be encountered, as to the character, quality, and scope of Work, the quantities of materials to be furnished, and as to the requirements of the Bidding Documents Proposal, Plans, and Specifications.
- 32. CITY STANDARD PROVISIONS.** This contract is subject to the following standard provisions. See The WHITEBOOK for details.
- 32.1.** The City of San Diego Resolution No. R-277952 adopted on May 20, 1991 for a Drug-Free Workplace.
- 32.2.** The City of San Diego Resolution No. R-282153 adopted on June 14, 1993 related to the Americans with Disabilities Act.
- 32.3.** The City of San Diego Municipal Code §22.3004 for Pledge of Compliance.
- 32.4.** The City of San Diego's Labor Compliance Program and the State of California Labor Code §§1771.5(b) and 1776.

- 32.5. Sections 1777.5, 1777.6, and 1777.7 of the State of California Labor Code concerning the employment of apprentices by contractors and subcontractors performing public works contracts.
- 32.6. The City’s Equal Benefits Ordinance (EBO), Chapter 2, Article 2, Division 43 of The San Diego Municipal Code (SDMC).
- 32.7. The City’s Information Security Policy (ISP) as defined in the City’s Administrative Regulation 90.63.

33. PRE-AWARD ACTIVITIES:

- 33.1. The selected contractor by the City to execute a contract for this Work shall provide the information required within the time specified in “Required Documents,” of this bid package. Failure to provide the information within the time specified may result in the Bid being rejected as **non-responsive**.
- 33.2. If the Bid is rejected as non-responsive, the selected contractor by the City to execute a contract for this Work shall forfeit the required Bid. The decision that the selected contractor by the City to execute a contract for this Work is non-responsive for failure to provide the information required within the time specified shall be at the sole discretion of the City.

34. ADDITIVE/DEDUCTIVE ALTERNATES:

- 34.1. The additive/deductive alternates have been established to allow the City to compare the cost of specific portions of the Work with the Project’s budget and enable the City to make decision prior to award. The award will be established as described in the Bid. The City reserves the right to award the Contract for the Base Bid only or the Base Bid plus any combination of Additive and Deductive Alternate(s).
- 34.2. For water pipeline projects, the Plans typically show all cut and plug and connection work to be performed by City Forces. However, Bidders shall refer to Bidding Documents to see if all or part of this work will be performed by the Contractor.

35. REQUIRED DOCUMENT SCHEDULE:

- 35.1. The Bidder’s attention is directed to the City’s Municipal Code §22.0807(e), (3)-(5) for important information regarding grounds for debarment for failure to submit required documentation.
- 35.2. The specified Equal Opportunity Contracting Program (EOCP) forms are available for download from the City’s web site at:

<http://www.sandiego.gov/eoc/forms/index.shtml>

ITEM	WHEN DUE	FROM	DOCUMENT TO BE SUBMITTED
1.	BID SUBMITTAL DATE/TIME	ALL BIDDERS	Bid
2.	BID SUBMITTAL DATE/TIME	ALL BIDDERS	Bid Bond
3.	BID SUBMITTAL DATE/TIME	ALL BIDDERS	Non-collusion Affidavit to be Executed By Bidder and Submitted with Bid under 23 USC 112 and PCC 7106

ITEM	WHEN DUE	FROM	DOCUMENT TO BE SUBMITTED
4.	BID SUBMITTAL DATE/TIME	ALL BIDDERS	Contractors Certification of Pending Actions
5.	BID SUBMITTAL DATE/TIME	ALL BIDDERS	Equal Benefits Ordinance Certification of Compliance
6.	BID SUBMITTAL DATE/TIME	ALL BIDDERS	Form AA35 - List of Subcontractors
7.	BID SUBMITTAL DATE/TIME	ALL BIDDERS	Form AA40 - Named Equipment/Material Supplier List
8.	BID SUBMITTAL DATE/TIME	ALL BIDDERS	Form AA45 - Subcontractors Additive/Deductive Alternate
9.	WITHIN 3 WORKING DAYS OF BID OPENING WITH GOOD FAITH EFFORT DOCUMENTATION	ALL BIDDERS	SLBE Good Faith Efforts Documentation
10.	WITHIN 3 WORKING DAYS OF BID OPENING WITH GOOD FAITH EFFORT DOCUMENTATION	ALL BIDDERS	Form AA60 – List of Work Made Available
11.	WITHIN 3 WORKING DAYS OF BID OPENING WITH GOOD FAITH EFFORT DOCUMENTATION	ALL BIDDERS	Proof of Valid DBE-MBE-WBE-DVBE Certification Status e.g., Certs.
12.	WITHIN 10 WORKING DAYS AFTER RECEIPT BY BIDDER OF CONTRACT FORMS	APPARENT LOW BIDDER	Names of the principal individual owners of the Apparent Low Bidder
13.	WITHIN 10 WORKING DAYS AFTER RECEIPT BY BIDDER OF CONTRACT FORMS	APPARENT LOW BIDDER	If the Contractor is a Joint Venture: <ul style="list-style-type: none"> • Joint Venture Agreement • Joint Venture License
14.	WITHIN 10 WORKING DAYS AFTER RECEIPT BY BIDDER OF CONTRACT FORMS	APPARENT LOW BIDDER	Form BB05 - Work Force Report
15.	WITHIN 10 WORKING DAYS AFTER RECEIPT BY BIDDER OF CONTRACT FORMS	APPARENT LOW BIDDER	Contract Forms - Agreement
16.	WITHIN 10 WORKING DAYS AFTER RECEIPT BY BIDDER OF CONTRACT FORMS	APPARENT LOW BIDDER	Contract Forms - Payment and Performance Bond
17.	WITHIN 10 WORKING DAYS AFTER RECEIPT BY BIDDER OF CONTRACT FORMS	APPARENT LOW BIDDER	Certificates of Insurance and Endorsements
18.	WITHIN 10 WORKING DAYS AFTER RECEIPT BY BIDDER OF CONTRACT FORMS	APPARENT LOW BIDDER	Contractor Certification - Drug-Free Workplace
19.	WITHIN 10 WORKING DAYS AFTER RECEIPT BY BIDDER OF CONTRACT FORMS	APPARENT LOW BIDDER	Contractor Certification - American with Disabilities Act
20.	WITHIN 10 WORKING DAYS AFTER RECEIPT BY BIDDER OF CONTRACT FORMS	APPARENT LOW BIDDER	Contractors Standards - Pledge of Compliance

CONTRACT FORMS
AGREEMENT

CONTRACT FORMS AGREEMENT

CONSTRUCTION CONTRACT

This contract is made and entered into between THE CITY OF SAN DIEGO, a municipal corporation, herein called "City", and TRI GROUP CONSTRUCTION & DEVELOPMENT INC., herein called "Contractor" for construction of 25th Street Renaissance Project; Bid No. K-14-5524-DBB-3; in the amount of ONE MILLION SEVEN HUNDRED TWENTY-SIX THOUSAND NINE HUNDRED FIFTY-SEVEN DOLLARS AND 00/100 (\$1,726,957.00), which is comprised of the Base Bid plus Additive Alternates A and B.

IN CONSIDERATION of the payments to be made hereunder and the mutual undertakings of the parties hereto, City and Contractor agree as follows:

1. The following are incorporated into this contract as though fully set forth herein:
 - (a) The attached Faithful Performance and Payment Bonds.
 - (b) The attached Proposal included in the Bid documents by the Contractor.
 - (c) Reference Standards listed in the Notice Inviting Bids and the Supplementary Special Provisions (SSP).
 - (d) That certain documents entitled 25th Street Renaissance Project, on file in the office of the Public Works Department as Document No. S-00985, B-12016, as well as all matters referenced therein.
2. The Contractor shall perform and be bound by all the terms and conditions of this contract and in strict conformity therewith shall perform and complete in a good and workmanlike manner 25th Street Renaissance Project, Bid Number K-14-5524-DBB-3, San Diego, California.
3. For such performances, the City shall pay to Contractor the amounts set forth at the times and in the manner and with such additions or deductions as are provided for in this contract, and the Contractor shall accept such payment in full satisfaction of all claims incident to such performances.
4. No claim or suit whatsoever shall be made or brought by Contractor against any officer, agent, or employee of the City for or on account of anything done or omitted to be done in connection with this contract, nor shall any such officer, agent, or employee be liable hereunder.
5. This contract is effective as of the date that the Mayor or designee signs the agreement.

CONTRACT FORMS (continued)

AGREEMENT

IN WITNESS WHEREOF, this Agreement is signed by the City of San Diego, acting by and through its Mayor or designee, pursuant to Municipal Code §22.3102 authorizing such execution.

THE CITY OF SAN DIEGO

APPROVED AS TO FORM AND LEGALITY

By 

Jan I. Goldsmith, City Attorney

By 

Print Name: _____
Stephen Samara
Senior Contract Specialist

Print Name: RYAN P. GERBERTY
Deputy City Attorney

Date: 2/5/14

Date: 2/4/2014

CONTRACTOR

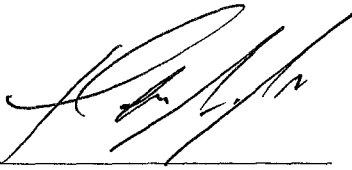
By 

HANI ASSI

Print Name: _____

Title: SECRETARY OF CORPORATION

Date: 12-31-2013

City of San Diego License No.: 2003004679

State Contractor's License No.: 792159

**CONTRACT/AGREEMENT
ATTACHMENTS**

PREMIUM IS FOR CONTRACT TERM
AND IS SUBJECT TO ADJUSTMENT
BASED ON FINAL CONTRACT PRICE

EXECUTED IN TRIPLICATE
BOND NO. 2169294
PREMIUM: \$15,367.00

CONTRACT ATTACHMENT PERFORMANCE BOND AND LABOR AND MATERIALMEN'S BOND

FAITHFUL PERFORMANCE BOND AND LABOR AND MATERIALMEN'S BOND:

TRI GROUP CONSTRUCTION & DEVELOPMENT INC., a corporation, as principal, and NORTH AMERICAN SPECIALTY INSURANCE COMPANY, a corporation authorized to do business in the State of California, as Surety, hereby obligate themselves, their successors and assigns, jointly and severally, to The City of San Diego a municipal corporation, in the sum of ONE MILLION SEVEN HUNDRED TWENTY-SIX THOUSAND NINE HUNDRED FIFTY-SEVEN DOLLARS AND 00/100 (\$1,726,957.00), for the faithful performance of the annexed contract, and in the sum of ONE MILLION SEVEN HUNDRED TWENTY-SIX THOUSAND NINE HUNDRED FIFTY-SEVEN DOLLARS AND 00/100 (\$1,726,957.00), for the benefit of laborers and materialmen designated below.

Conditions:

If the Principal shall faithfully perform the annexed contract 25th Street Renaissance Project, Bid Number K-14-5524-DBB-3, San Diego, California then the obligation herein with respect to a faithful performance shall be void; otherwise it shall remain in full force.

If the Principal shall promptly pay all persons, firms and corporations furnishing materials for or performing labor in the execution of this contract, and shall pay all amounts due under the California Unemployment Insurance Act then the obligation herein with respect to laborers and materialmen shall be void; otherwise it shall remain in full force.

The obligation herein with respect to laborers and materialmen shall inure to the benefit of all persons, firms and corporations entitled to file claims under the provisions of Chapter 3 of Division 5 of Title I of the Government Code of the State of California or under the provisions of Section 3082 et seq. of the Civil Code of the State of California.

Changes in the terms of the annexed contract or specifications accompanying same or referred to therein shall not affect the Surety's obligation on this bond, and the Surety hereby waives notice of same.

CONTRACT ATTACHMENT (continued)
PERFORMANCE BOND AND LABOR AND MATERIALMEN'S BOND

The Surety shall pay reasonable attorney's fees should suit be brought to enforce the provisions of this bond.

Dated JANUARY 2, 2014

Approved as to Form and Legality

TRI-GROUP CONSTRUCTION
AND DEVELOPMENT, INC.

Principal

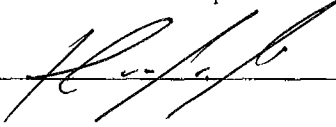
By 

HANI ASSI, SECRETARY

Printed Name of Person Signing for Principal

Jan I. Goldsmith, City Attorney

By 
Deputy City Attorney

NORTH AMERICAN
SPECIALTY INSURANCE COMPANY

Surety

By 

MARK D. IATAROLA, Attorney-in-fact

Approved:

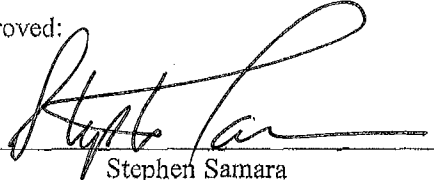
By 
Stephen Samara
Senior Contract Specialist

6 HUTTON CENTRE DRIVE, SUITE 850

Local Address of Surety

SANTA ANA, CA 92707

Local Address (City, State) of Surety

714/550-7799

Local Telephone No. of Surety

PREMIUM IS FOR CONTRACT TERM
AND IS SUBJECT TO ADJUSTMENT
BASED ON FINAL CONTRACT PRICE

Premium \$ 15,367.00

Bond No. 2169294

CALIFORNIA ALL-PURPOSE ACKNOWLEDGMENT

STATE OF CALIFORNIA

County of SAN DIEGO }

On 1/2/2014 before me, MICHELLE M. BASUIL, NOTARY PUBLIC
Date Here Insert Name and Title of the Officer

personally appeared MARK D. IATAROLA
Name(s) of Signer(s)

who proved to me on the basis of satisfactory evidence to be the person~~(s)~~ whose name~~(s)~~ is/~~are~~ subscribed to the within instrument and acknowledged to me that he/~~she/they~~ executed the same in his/~~her/their~~ authorized capacity~~(ies)~~, and that by his/~~her/their~~ signature~~(s)~~ on the instrument the person~~(s)~~, or the entity upon behalf of which the person~~(s)~~ acted, executed the instrument.



Place Notary Seal Above

I certify under PENALTY OF PERJURY under the laws of the State of California that the foregoing paragraph is true and correct.

Witness my hand and official seal.

Signature Michelle M. Basuil
Signature of Notary Public

OPTIONAL

Though the information below is not required by law, it may prove valuable to persons relying on the document and could prevent fraudulent removal and reattachment of this form to another document.

Description of Attached Document

Title or Type of Document: PERFORMANCE BOND AND LABOR AND MATERIALMEN'S BOND

Document Date: 1/2/2014 Number of Pages: 2

Signer(s) Other Than Named Above: _____

Capacity(ies) Claimed by Signer(s)

Signer's Name: MARK D. IATAROLA

- Individual
- Corporate Officer — Title(s): _____
- Partner — Limited General
- Attorney in Fact
- Trustee
- Guardian or Conservator
- Other: _____

RIGHT THUMBPRINT OF SIGNER

Top of thumb here

Signer Is Representing:

Signer's Name: _____

- Individual
- Corporate Officer — Title(s): _____
- Partner — Limited General
- Attorney in Fact
- Trustee
- Guardian or Conservator
- Other: _____

RIGHT THUMBPRINT OF SIGNER

Top of thumb here

Signer Is Representing:

NAS SURETY GROUP

NORTH AMERICAN SPECIALTY INSURANCE COMPANY
WASHINGTON INTERNATIONAL INSURANCE COMPANY

GENERAL POWER OF ATTORNEY

KNOW ALL MEN BY THESE PRESENTS, THAT North American Specialty Insurance Company, a corporation duly organized and existing under laws of the State of New Hampshire, and having its principal office in the City of Manchester, New Hampshire, and Washington International Insurance Company, a corporation organized and existing under the laws of the State of New Hampshire and having its principal office in the City of Schaumburg, Illinois, each does hereby make, constitute and appoint:

JOHN G. MALONEY, HELEN MALONEY, MICHELLE M. BASUIL,
GLEND A. J. GARDNER, MARK D. IATAROLA and DEBORAH D. DAVIS

JOINTLY OR SEVERALLY

Its true and lawful Attorney(s)-in-Fact, to make, execute, seal and deliver, for and on its behalf and as its act and deed, bonds or other writings obligatory in the nature of a bond on behalf of each of said Companies, as surety, on contracts of suretyship as are or may be required or permitted by law, regulation, contract or otherwise, provided that no bond or undertaking or contract or suretyship executed under this authority shall exceed the amount of:

FIFTY MILLION (\$50,000,000.00) DOLLARS

This Power of Attorney is granted and is signed by facsimile under and by the authority of the following Resolutions adopted by the Boards of Directors of both North American Specialty Insurance Company and Washington International Insurance Company at meetings duly called and held on the 9th of May, 2012:

RESOLVED, that any two of the Presidents, any Managing Director, any Senior Vice President, any Vice President, any Assistant Vice President, the Secretary or any Assistant Secretary be, and each or any of them hereby is authorized to execute a Power of Attorney qualifying the attorney named in the given Power of Attorney to execute on behalf of the Company bonds, undertakings and all contracts of surety, and that each or any of them hereby is authorized to attest to the execution of any such Power of Attorney and to attach therein the seal of the Company; and it is

FURTHER RESOLVED, that the signature of such officers and the seal of the Company may be affixed to any such Power of Attorney or to any certificate relating thereto by facsimile, and any such Power of Attorney or certificate bearing such facsimile signatures or facsimile seal shall be binding upon the Company when so affixed and in the future with regard to any bond, undertaking or contract of surety to which it is attached.



By [Signature]
Steven P. Anderson, Senior Vice President of Washington International Insurance Company
& Senior Vice President of North American Specialty Insurance Company



By [Signature]
David M. Layman, Vice President of Washington International Insurance Company
& Vice President of North American Specialty Insurance Company

IN WITNESS WHEREOF, North American Specialty Insurance Company and Washington International Insurance Company have caused their official seals to be hereunto affixed, and these presents to be signed by their authorized officers this 10th day of December, 2012.

North American Specialty Insurance Company
Washington International Insurance Company

State of Illinois
County of Cook ss:

On this 10th day of December, 2012, before me, a Notary Public personally appeared Steven P. Anderson, Senior Vice President of Washington International Insurance Company and Senior Vice President of North American Specialty Insurance Company and David M. Layman, Vice President of Washington International Insurance Company and Vice President of North American Specialty Insurance Company, personally known to me, who being by me duly sworn, acknowledged that they signed the above Power of Attorney as officers of and acknowledged said instrument to be the voluntary act and deed of their respective companies.

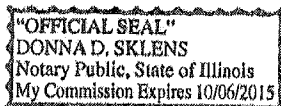

[Signature]
Donna D. Sklens, Notary Public

I, Jeffrey Goldberg, the duly elected Assistant Secretary of North American Specialty Insurance Company and Washington International Insurance Company, do hereby certify that the above and foregoing is a true and correct copy of a Power of Attorney given by said North American Specialty Insurance Company and Washington International Insurance Company, which is still in full force and effect.

IN WITNESS WHEREOF, I have set my hand and affixed the seals of the Companies this 2ND day of JANUARY, 2014.

[Signature]
Jeffrey Goldberg, Vice President & Assistant Secretary of
Washington International Insurance Company & North American Specialty Insurance Company

CONTRACTOR CERTIFICATION

DRUG-FREE WORKPLACE

PROJECT TITLE: 25th Street Renaissance Project

I hereby certify that I am familiar with the requirements of San Diego City Council Policy No. 100-17 regarding Drug-Free Workplace as outlined in the WHITEBOOK, Section 7-13.3, "Drug-Free Workplace", of the project specifications, and that;

**TRI-GROUP
CONSTRUCTION AND
DEVELOPMENT, INC.**

(Name under which business is conducted)

has in place a drug-free workplace program that complies with said policy. I further certify that each subcontract agreement for this project contains language which indicates the subcontractor's agreement to abide by the provisions of subdivisions a) through c) of the policy as outlined.

Signed _____

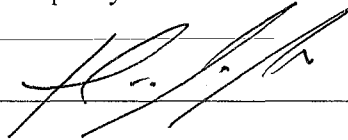

HANI ASSI

Printed Name _____

Title _____

SECRETARY OF CORPORATION

CONTRACTOR CERTIFICATION

AMERICAN WITH DISABILITIES ACT (ADA) COMPLIANCE CERTIFICATION

PROJECT TITLE: 25th Street Renaissance Project

I hereby certify that I am familiar with the requirements of San Diego City Council Policy No. 100-4 regarding the American With Disabilities Act (ADA) outlined in the WHITEBOOK, Section 7-13.2, "American With Disabilities Act", of the project specifications, and that;

**TRI-GROUP
CONSTRUCTION AND
DEVELOPMENT, INC.**

(Name under which business is conducted)

has in place a workplace program that complies with said policy. I further certify that each subcontract agreement for this project contains language which indicates the subcontractor's agreement to abide by the provisions of the policy as outlined.

Signed  _____

HANI ASSI

Printed Name _____

SECRETARY OF CORPORATION

Title _____

CONTRACTOR CERTIFICATION

CONTRACTOR STANDARDS – PLEDGE OF COMPLIANCE

PROJECT TITLE: 25th Street Renaissance Project

I declare under penalty of perjury that I am authorized to make this certification on behalf of TRI-GROUP CONSTRUCTION & DEV. INC. as Contractor, that I am familiar with the requirements of City of San Diego Municipal Code § 22.3224 regarding Contractor Standards as outlined in the WHITEBOOK, Section 7-13.4, ("Contractor Standards"), of the project specifications, and that Contractor has complied with those requirements.

I further certify that each of the Contractor's subcontractors whose subcontracts are greater than \$50,000 in value has completed a Pledge of Compliance attesting under penalty of perjury of having complied with City of San Diego Municipal Code § 22.3224.

Dated this 31ST Day of DEC., 2013.

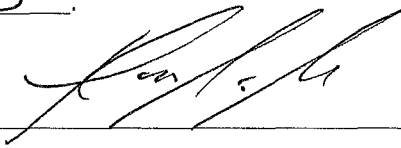
Signed  _____

HANI ASSI

Printed Name _____

Title **SECRETARY OF CORPORATION** _____

AFFIDAVIT OF DISPOSAL

WHEREAS, on the _____ DAY OF _____, _____, the undersigned entered into and executed a contract with the City of San Diego, a municipal corporation, for:

25th Street Renaissance Project
(Name of Project)

as particularly described in said contract and identified as Bid No. **K-14-5524-DBB-3**; SAP No. (WBS/IO/CC) **S-00985, B-12016**; and WHEREAS, the specification of said contract requires the Contractor to affirm that "all brush, trash, debris, and surplus materials resulting from this project have been disposed of in a legal manner"; and WHEREAS, said contract has been completed and all surplus materials disposed of:

NOW, THEREFORE, in consideration of the final payment by the City of San Diego to said Contractor under the terms of said contract, the undersigned Contractor, does hereby affirm that all surplus materials as described in said contract have been disposed of at the following location(s)

and that they have been disposed of according to all applicable laws and regulations.

Dated this _____ DAY OF _____, _____.

by _____ Contractor

ATTEST:

State of _____
County of _____

On this _____ DAY OF _____, 2_____, before the undersigned, a Notary Public in and for said County and State, duly commissioned and sworn, personally appeared _____ known to me to be the _____ Contractor named in the foregoing Release, and whose name is subscribed thereto, and acknowledged to me that said Contractor executed the said Release.

Notary Public in and for said County and State

COMPANY LETTERHEAD

CERTIFICATE OF COMPLIANCE

Materials and Workmanship Compliance

For Contract _____

I certify that the material listed below complies with the materials and workmanship requirements of the Caltrans Contract Plans, Special Provisions, Standard Specifications, and Standard Plans for the contract listed above.

I also certify that I am an official representative for _____, the manufacturer of the material listed above. Furthermore, I certify that where California test methods, physical or chemical test requirements are part of the specifications, that the manufacturer has performed the necessary quality control to substantiate this certification.

Material Description:

Manufacturer: _____
Model: _____
Serial Number (if applicable) _____
Quantity to be supplied: _____
Remarks: _____

Signed by: _____

Printed Name: _____

Title: _____

Company: _____

Date: _____

**City of San Diego
Engineering and Capital Projects, Field Division**

NOTICE OF MATERIALS TO BE USED

To: _____
Resident Engineer

Date: _____, 2 _____

You are hereby notified that the materials required for use under Contract No. _____ for construction of _____, in the City of San Diego, will be obtained from sources herein designated.

CONTRACT ITEM NO. (Bid Item)	KIND OF MATERIAL (Category)	NAME AND ADDRESS WHERE MATERIAL CAN BE INSPECTED (At Source)

It is requested that you arrange for a sampling, testing, and inspection of the materials prior to delivery, in accordance with Section 4-1.11 of the WHITEBOOK, where it is practicable, and in accordance with your policy. It is understood that source inspection does not relieve the Contractor of full responsibility for incorporating in the work, materials that comply in all respects with the contract plans and specifications, nor does it preclude subsequent rejection of materials found to be undesirable or unsuitable.

Distribution:

Supplier

Yours truly,

Signature of Supplier

Address

Phone Number: _____

SUPPLEMENTARY SPECIAL PROVISIONS (SSP)

SUPPLEMENTARY SPECIAL PROVISIONS

The following Supplementary Special Provisions (SSP) modifies the following documents:

- 1) Standard Specifications for Public Works Construction (The GREENBOOK) currently in effect.
- 2) The City of San Diego Standard Specifications for Public Works Construction (The WHITEBOOK).

SECTION 1 – TERMS, DEFINITIONS, ABBREVIATIONS, UNITS OF MEASURE, AND SYMBOLS

1-2 TERMS AND DEFINITIONS.

Normal Working Hours. To the City Supplement, ADD the following:

The Normal Working Hours are 8:30 AM to 3:30 PM.

SECTION 2 - SCOPE AND CONTROL OF WORK

2-3.2 Self Performance. DELETE in its entirety and SUBSTITUTE with the following:

1. You must perform, with your own organization, Contract work amounting to at least 50% of the base bid alone or base bid and any additive or deductive alternate(s) that together when added or deducted form the basis of award.
2. The self performance percentage requirement will be waived for contracts when a “B” License is required or allowed.

2-7 SUBSURFACE DATA. ADD the following:

4. In preparation of the Contract Documents, the designer has relied upon the following reports of explorations and tests of subsurface conditions at the Work Site:
 1. Geotechnical Services Report dated April 1, 2011 by Geocon, Inc.
5. The report(s) listed above is(are) available for review by contacting the City Contract Specialist or visiting:

<ftp://ftp.sannet.gov/OUT/DLi/25th%20Street%20Renaissance/>

2-14.2 Integration of the Work with Separate Contractors. To the City Supplement, ADD the following:

The list of Separate Contractors includes:

1. City Forces

2-14.3 Coordination. To the City Supplement, ADD the following:

Other adjacent City project is scheduled for construction for the same time period in the vicinity of 25th Street & B Street and on 25th Street & E Street. See Appendix "H" for approximate locations. Coordinate the Work with the adjacent project as listed below:

- a) Water Group Job 959, Luis Schaar (619-533-7492)

SECTION 4 - CONTROL OF MATERIALS

ADD:

4-1.1.1 Buy America.

4.1.1.2 Steel and Iron Materials (23 CFR 635.410). Furnish steel and iron materials to be incorporated into the work with certificates of compliance. Steel and iron materials must be produced in the U.S. except:

1. Foreign pig iron and processed, pelletized, and reduced iron ore may be used in the domestic production of the steel and iron materials [60 Fed Reg 15478 (03/24/1995)].
2. If the total combined cost of the materials does not exceed the greater of 0.1 percent of the total bid or \$2,500, materials produced outside the U.S. may be used.

Production includes:

1. Processing steel and iron materials, including smelting or other processes that alter the physical form or shape (such as rolling, extruding, machining, bending, grinding, and drilling) or chemical composition.
2. Coating application, including epoxy coating, galvanizing, and painting, that protects or enhances the value of steel and iron materials.

4-1.6 Trade Names or Equals. ADD the following:

You must submit your list of proposed substitutions for “an equal” (“or equal”) item(s) **no later than 5 Working Days after the determination of the Apparent Low Bidder** and on a City form when provided by the City.

SECTION 6 – PROSECUTION, PROGRESS, AND ACCEPTANCE OF THE WORK

6-7.1 General. ADD the following:

The following must be included in the stipulated Contract Time:

1. 30 Working Days for the first phase and 10 Working Days for each subsequent phase for City Force high-line work for water mains (if applicable).
2. 30 Working Days for the City Forces TV inspection of sewer mains (if applicable).

3. Number of Working Days specified for Walk-through and preparation and completion of Punchlist items.
4. If weather condition is suitable, complete each street segment within 15 Working Days from the day the slurry seal or asphalt overlay is placed. Each completed segment must include other incidental Work items e.g., weed abatement, damaged asphalt pavement replacement, asphalt patching, resurfacing, striping, markings, raised pavement markers, and inlet markers.
5. For Water project where shutdowns of 16 inch and larger pipes are required, there is a shutdown moratorium from May until October. Contractor shall plan and schedule working accordingly. No additional payment or working days will be granted for delays due to this moratorium.

SECTION 7 - RESPONSIBILITIES OF THE CONTRACTOR

7-3 **LIABILITY INSURANCE.** DELETE in its entirety and SUBSTITUTE with the following:

The insurance provisions herein must not be construed to limit your indemnity obligations contained in the Contract.

7-3.1 Policies and Procedures.

1. You must procure the insurance described below, at its sole cost and expense, to provide coverage against claims for loss including injuries to persons or damage to property, which may arise out of or in connection with the performance of the Work by you, your agents, representatives, officers, employees or Subcontractors.
2. Insurance coverage for property damage resulting from your operations is on a replacement cost valuation. The market value will not be accepted.
3. You must maintain this insurance for the duration of this contract and at all times thereafter when you are correcting, removing, or replacing Work in accordance with this contract. Your liabilities under the Contract, e.g., your indemnity obligations, is not deemed limited to the insurance coverage required by this contract.
4. Payment for insurance is included in the various items of Work as bid by you, and except as specifically agreed to by the City in writing, you are not entitled to any additional payment. Do not begin any work under this contract until you have provided and the City has approved all required insurance.
5. Policies of insurance must provide that the City is entitled to 30 days (10 days for cancellation due to non-payment of premium) prior written notice of cancellation or non-renewal of the policy. Maintenance of specified insurance coverage is a material element of the Contract. Your failure to maintain or renew coverage or to provide evidence of renewal during the term of the Contract may be treated by the City as a material breach of the Contract.

7-3.2 Types of Insurance.

7-3.2.1 Commercial General Liability Insurance.

1. Commercial General Liability Insurance must be written on the current version of the ISO Occurrence form CG 00 01 07 98 or an equivalent form providing coverage at least as broad.
2. The policy must cover liability arising from premises and operations, XCU (explosions, underground, and collapse), independent contractors, products/completed operations, personal injury and advertising injury, bodily injury, property damage, and liability assumed under an insured’s contract (including the tort liability of another assumed in a business contract).
3. There must be no endorsement or modification limiting the scope of coverage for either “insured vs. insured” claims or contractual liability. You must maintain the same or equivalent insurance for at least 10 years following completion of the Work.
4. All costs of defense must be outside the policy limits. Policy coverage must be in liability limits of not less than the following:

<u>General Annual Aggregate Limit</u>	<u>Limits of Liability</u>
Other than Products/Completed Operations	\$2,000,000
Products/Completed Operations Aggregate Limit	\$2,000,000
Personal Injury Limit	\$1,000,000
Each Occurrence	\$1,000,000

7-3.2.2 Commercial Automobile Liability Insurance.

1. You must provide a policy or policies of Commercial Automobile Liability Insurance written on the current version of the ISO form CA 00 01 12 90 or later version or equivalent form providing coverage at least as broad in the amount of \$1,000,000 combined single limit per accident, covering bodily injury and property damage for owned, non-owned, and hired automobiles (“Any Auto”).
2. All costs of defense must be outside the limits of the policy.

7-3.3 Rating Requirements. Except for the State Compensation Insurance Fund, all insurance required by this contract as described herein must be carried only by responsible insurance companies with a rating of, or equivalent to, at least “A-, VI” by A.M. Best Company, that are authorized by the California Insurance Commissioner to do business in the State, and that have been approved by the City.

7-3.3.1 Non-Admitted Carriers. The City will accept insurance provided by non-admitted, “surplus lines” carriers only if the carrier is authorized to do business in the State and is included on the List of Approved Surplus Lines Insurers (LASLI list).

All policies of insurance carried by non-admitted carriers must be subject to all of the requirements for policies of insurance provided by admitted carriers described herein.

7-3.4 Evidence of Insurance. Furnish to the City documents e.g., certificates of insurance and endorsements evidencing the insurance required herein, and furnish renewal documentation prior to expiration of this insurance. Each required document must be signed by the insurer or a person authorized by the insurer to bind coverage on its behalf. We reserve the right to require complete, certified copies of all insurance policies required herein.

7-3.5 Policy Endorsements.

7-3.5.1 Commercial General Liability Insurance.

7-3.5.1.1 Additional Insured.

- a) You must provide at your expense policy endorsement written on the current version of the ISO Occurrence form CG 20 10 11 85 or an equivalent form providing coverage at least as broad.
- b) To the fullest extent allowed by law e.g., California Insurance Code §11580.04, the policy must be endorsed to include the City and its respective elected officials, officers, employees, agents, and representatives as additional insured.
- c) The additional insured coverage for projects for which the Engineer's Estimate is \$1,000,000 or more must include liability arising out of: (a) Ongoing operations performed by you or on your behalf, (b) your products, (c) your work, e.g., your completed operations performed by you or on your behalf, or (d) premises owned, leased, controlled, or used by you.
- d) The additional insured coverage for projects for which the Engineer's Estimate is less than \$1,000,000 must include liability arising out of: (a) Ongoing operations performed by you or on your behalf, (b) your products, or (c) premises owned, leased, controlled, or used by you.

7-3.5.1.2 Primary and Non-Contributory Coverage. The policy must be endorsed to provide that the coverage with respect to operations, including the completed operations, if appropriate, of the Named Insured is primary to any insurance or self-insurance of the City and its elected officials, officers, employees, agents and representatives. Further, it must provide that any insurance maintained by the City and its elected officials, officers, employees, agents and representatives must be in excess of your insurance and must not contribute to it.

7-3.5.1.3 Project General Aggregate Limit. The policy or policies must be endorsed to provide a Designated Construction Project General Aggregate Limit that will apply only to the Work. Only claims payments which arise from the Work must reduce the Designated Construction Project General Aggregate Limit. The Designated Construction Project General Aggregate Limit must be in addition to the aggregate limit provided for the products-completed operations hazard.

7-3.5.2 Commercial Automobile Liability Insurance.

7-3.5.2.1 Additional Insured. Unless the policy or policies of Commercial Auto Liability Insurance are written on an ISO form CA 00 01 12 90 or a later version of this form or equivalent form providing coverage at least as broad, the policy must be endorsed to

include the City and its respective elected officials, officers, employees, agents, and representatives as additional insured, with respect to liability arising out of automobiles owned, leased, hired or borrowed by you or on your behalf. This endorsement is limited to the obligations permitted by California Insurance Code §11580.04.

7-3.6 Deductibles and Self-Insured Retentions. You must pay for all deductibles and self-insured retentions. You must disclose deductibles and self-insured retentions to the City at the time the evidence of insurance is provided.

7-3.7 Reservation of Rights. The City reserves the right, from time to time, to review your insurance coverage, limits, deductibles and self-insured retentions to determine if they are acceptable to the City. The City will reimburse you, without overhead, profit, or any other markup, for the cost of additional premium for any coverage requested by the Engineer but not required by this contract.

7-3.8 Notice of Changes to Insurance. You must notify the City 30 days prior to any material change to the policies of insurance provided under this contract.

7-3.9 Excess Insurance. Policies providing excess coverage must follow the form of the primary policy or policies e.g., all endorsements.

7-3.10 Architects and Engineers Professional Insurance (Errors and Omissions Insurance).

1. For contracts with required engineering services (e.g., Design-Build, preparation of engineered Traffic Control Plans (TCP), etc. by the Contractor) for all of your employees or Subcontractors who provide professional engineering services under this contract, you must keep or must require its Subcontractor keep in full force and effect, Professional Liability coverage with a limit of **\$1,000,000** per claim and **\$2,000,000** annual aggregate.
2. You must ensure both that: (a) the policy retroactive date is on or before the date of commencement of the Project; and (b) the policy will be maintained in force for a period of 3 years after completion of the Project or termination of this contract whichever occurs last. You agree that for the time period specified above, there will be no changes or endorsements to the policy that affect the specified coverage.
3. If professional engineering services are to be provided solely by the Subcontractor, you must (a) certify this to the City in writing and (b) agree in writing to require the Subcontractor to procure Professional Liability coverage in accordance with the requirements set forth above.

7-4 WORKERS' COMPENSATION INSURANCE. DELETE in its entirety and SUBSTITUTE with the following:

7-4.1 Workers' Compensation Insurance and Employers Liability Insurance.

1. In accordance with the provisions of §3700 of the California Labor Code, you must provide at your expense Workers' Compensation Insurance and Employers Liability Insurance to protect you against all claims under applicable state workers compensation laws. The City, its elected officials,

and employees will not be responsible for any claims in law or equity occasioned by your failure to comply with the requirements of this section.

2. Limits for this insurance must be not less than the following:

<u>Workers' Compensation</u>	<u>Statutory Employers Liability</u>
Bodily Injury by Accident	\$1,000,000 each accident
Bodily Injury by Disease	\$1,000,000 each employee
Bodily Injury by Disease	\$1,000,000 policy limit

3. By signing and returning the Contract you certify that you are aware of the provisions of §3700 of the Labor Code which require every employer to be insured against liability for worker's compensation or to undertake self-insurance in accordance with the provisions of that code and you must comply with such provisions before commencing the Work as required by §1861 of the California Labor Code.

7-4.1.1 Waiver of Subrogation. The policy or policies must be endorsed to provide that the insurer will waive all rights of subrogation against the City, and its respective elected officials, officers, employees, agents, and representatives for losses paid under the terms of the policy or policies and which arise from work performed by the Named Insured for the City.

7-10.1.1.1 Vehicular Access. ADD the following:

Contractor shall notify business owners at least 2 weeks in advance of any work adjacent to the business. Business hours vary from business to business. For driveway removal and replacement, if a business has multiple driveways, Contractor shall schedule work so that at least 1 is open at all times. For any business with only 1 driveway, Contractor shall coordinate with each business and arrange for a method of construction that minimizes any impact to the business. Solutions can include: staging the work in phases so that access can be maintained, scheduling work outside of normal business days/hours, and/or arranging for the business to close for a day. Contractor may propose to use a special concrete mix design in accordance with 201-1 to obtain an early increase in strength, such that access can be restored within 24 hours.

Contractor shall perform the work at the Fire Station 11 driveway in 2 phases to ensure that at least 1 garage bay is accessible at all times. For the duration of the driveway work, Contractor shall reimburse the Fire Department for rental and delivery fees for 2 trailers that will be used to temporarily relocate Fire Station 11 personnel. Payment for the trailers shall be made out of the Reimbursement for Trailers allowance in the Bid. Contractor shall use a special concrete mix design in accordance with 201-1 to obtain a 3250 psi compressive strength not to exceed 5 days. Contractor shall provide the Resident Engineer with a construction schedule 5 weeks in advance of performing the driveway work, so proper coordination with Fire Station 11 can be made.

7-10.1.1.2 Pedestrian Access. ADD the following:

Contractor shall notify business owners at least 2 weeks in advance of any work adjacent to the business. Business hours vary from business to business. For sidewalk removal and replacement which affects access to the business, Contractor

shall coordinate with each business and arrange for a method of construction that minimizes any impact to the business. Solutions can include staging the work in phases so that access can be maintained, scheduling work outside of normal business days/hours, and/or arranging for the business to close for a day.

Contractor may propose to use a special concrete mix design in accordance with 201-1 to obtain an early increase in strength, such that access can be restored within 24 hours.

7-10.5.3 Steel Plate Covers. Table 7-10.5.3(A), REVISE the plate thickness for 5'-3" trench width to read 1 3/4".

7-15 INDEMNIFICATION AND HOLD HARMLESS AGREEMENT. To the City Supplement, fourth paragraph, last sentence, DELETE in its entirety and SUBSTITUTE with the following:

Your duty to indemnify and hold harmless does not include any claims or liability arising from the established active or sole negligence, or willful misconduct of the City, its officers, or employees.

SECTION 8 - FACILITIES FOR AGENCY PERSONNEL

8-2 FIELD OFFICE FACILITIES. To the City Supplement, DELETE in its entirety.

SECTION 9 - MEASUREMENT AND PAYMENT

9-3.1 General. ADD the following:

Site Furnishings consist of existing benches, newspaper racks, potted plants, trash receptacles, bus shelters, etc. as identified in the Plans to be relocated. Site Furnishings shall be relocated to the location shown on the Plans, in conformance with the Standard Specification and the Whitebook Standard Specifications.

The Contractor shall provide anchor inserts to match the existing anchors in kind (including matching finish), in the sidewalk at the new location.

Damaged components of the existing Site Furnishings as a result of the relocation shall be repaired or replaced as part of the relocation cost.

Newspaper Racks: Coordinate with newspaper rack owners and City prior to relocation.

Bus Shelter: Contractor shall notify Michele Shepard at MTS, 619-238-0100 x6451, at least 2 weeks prior to relocation of bus shelter.

9-3.2.5 Withholding of Payment. To the City Supplement, item i), DELETE in its entirety and SUBSTITUTE with the following:

- i) Your failure to comply with 7-2.3, "PAYROLL RECORDS" and 2-16, "CONTRACTOR REGISTRATION AND ELECTRONIC REPORTING SYSTEM."

ADD:

9-3.7 Compensation Adjustments for Price Index Fluctuations. This Contract is not subject to the provisions of The WHITEBOOK for Compensation Adjustments for Price Index Fluctuations for the paving asphalt.

SECTION 203 – BITUMINOUS MATERIALS

203-1.1 **General.** ADD the following:

Asphalt Concrete Paving shall include full depth asphalt patching and asphalt overlays, and shall be per the details shown on the plans, and in accordance with Sections 203-6 and 302-5 of the Standard Specifications, Sections 203, 302-5 and 400 of the Whitebook Standard Specifications, and these Special Provisions.

Paving asphalt shall be PG 64-10 in accordance with Table 203-1.2(A) of the Standard Specifications and Section 203 and Section 400 of the Whitebook Standard Specifications.

203-15 **RUBBER POLYMER MODIFIED SLURRY (RPMS).** RPMS shall be used on this contract.

SECTION 207 – PIPE

207-27 **FUSIBLE NON-PRESSURE POLYVINYLCHOLORIDE PIPE.** DELETE in its entirety.

SECTION 209 – STREET LIGHTING AND TRAFFIC SIGNAL MATERIALS

209-6.4 **Induction Cobra Head Luminaire.** To the City Supplement, CORRECT certain section numbering as follows:

OLD SECTION NUMBER	TITLE	NEW SECTION NUMBER
209-6.4.7	Luminaire Identification	209-6.4.8
209-6.4.8	Photometric Documentation	209-6.4.9
209-6.4.9	Quality Assurance	209-6.4.10

SECTION 300 – EARTHWORK

300-1.4 **Payment.** To the City Supplement, paragraph (2), DELETE in its entirety and SUBSTITUTE with the following:

2. Payment for existing pavement removal and disposal of up to 12” thick, within the excavation e.g., trench limits, shall be included in the Bid item for installation of the mains or the Work item that requires pavement removal.

SECTION 301 – TREATED SOIL, SUBGRADE PREPARATION, AND PLACEMENT OF BASE MATERIALS

301-1.7 Payment. To the City Supplement, ADD the following to the first paragraph:

The contractor shall inventory all existing utilities and other items that need to be adjusted to grade in order to complete the improvements, and notify the Engineer of any discrepancies that exist prior to construction. Adjustment of utilities to grade, shall include any concrete collars that are necessary to complete the adjustment to grade.

The lump sum price paid for Adjust Utilities to Grade shall include full compensation for furnishing all labor, materials, equipment, tools and incidentals for adjusting to grade any utilities such as water meters, water gate valves, backflow preventers, manholes, and pullboxes, as necessary to provide a smooth transition with the new roadway or sidewalk elevation.

301-3.3.6 Measurement and Payment of Cement-Treated Base (CTB). DELETE in its entirety and SUBSTITUTE with the following:

Cement-treated base and subbase shall be paid for by the Cubic Yard, complete in place as shown on the plans or as directed by the Engineer. Furnishing, mixing, spreading, shaping, compacting, trimming and curing of the treated materials shall be included in the Bid item for Cement Treated Base.

SECTION 302 – ROADWAY SURFACING

302-1.1 General. To the City Supplement, ADD the following:

20. The depth of cold milling shall be established by the finished grades shown on the plans and allowance for a minimum of 2” depth of new overlay with asphalt concrete.
21. Disposal of debris from cold milling shall be considered as included in the contract price paid for cold milling of existing asphalt concrete, and no additional compensation will be allowed therefore.
22. The Contractor shall provide keep public streets clean during cold milling operations, to the satisfaction of the Resident Engineer.
23. The Contractor shall provide temporary smooth transitions, using cold mix asphalt, where cold milling operations abuts existing surfaces, until final overlay of asphalt concrete has been completed. Cold mix materials shall be removed and disposed of, prior to tack coat and overlay.

302-1.3.1 General. ADD the following:

In areas where the depth of cold milling extends below the existing asphalt and into the existing concrete pavement, these areas shall be sawcut to full depth of existing section and demolished and disposed of.

302-1.6 Cold Milling of Composite Pavements. To the City Supplement, DELETE in its entirety.

To the Greenbook, DELETE the second and last sentences and REPLACE with the following:

The thickness of all existing pavement material was not known at the time of the project design. Any areas where it is necessary to cold mill to a depth that exceeds the thickness of the existing asphalt paving and extends down to the Portland cement concrete paving, shall be completely demolished and disposed of, per the requirements of "Clearing and Grubbing".

302-3 Preparatory Repair Work. To the City Supplement, DELETE in its entirety and SUBSTITUTE with the following:

302-3 Preparatory Repair Work.

1. Prior to roadway resurfacing or the application of slurry, the Contractor shall complete all necessary preparation and repair work to the road segment e.g., tree trimming, weed spray, weed abatement, crack sealing, asphalt repair, hump removal, miscellaneous asphalt patching, removal of raised pavement markers, removal of pavement markings, etc. and as specified in the Special Provisions.
2. Preparatory work shall include, but not be limited to, tree trimming, weed spray, weed abatement, crack sealing, asphalt repair i.e., mill and pave, hump removal, miscellaneous asphalt patching, removal of raised pavement markers, removal of pavement markings, etc.
3. The Contractor shall repair areas of distressed asphalt concrete pavement by milling or removing damaged areas of pavement to a minimum depth of 2" for Residential streets, and a minimum depth of 3" for all others to expose firm and unyielding pavement. The Contractor shall prepare subgrade as needed and install a minimum of 2" for residential streets, and a minimum of 3" for all others, of compacted asphalt concrete pavement over compacted native material as directed by the Engineer.
4. If, in order to achieve the minimum specified depth, the base material is exposed, the material shall be compacted to 95% relative compaction to a depth 10" below the finished grade (dig out). Compaction tests shall be made to ensure compliance with the specifications. The Engineer will determine when and where the test will occur. The City will pay for the soils testing required by the Engineer, which meets the required compaction. The Contractor shall reimburse the City for the cost of retesting failing compaction tests. If additional base material is required, the Contractor shall use Crushed Aggregate Base in accordance with 200-2.2, "Crushed Aggregate Base."
5. Recycled base material shall conform to Crushed Miscellaneous Base Material in accordance with 200-2.4.
6. Prior to replacing asphalt, the area shall be cleaned by removing all loose and damaged material, moisture, dirt, and other foreign matter and shall be tack coated in accordance with 302-5.4 "Tack Coat."

7. The Contractor shall install new asphalt within the repair area or for patches in accordance with 302-5, "ASPHALT CONCRETE PAVEMENT." Asphalt concrete shall be C2-PG 64-10 in compliance with 400-4, "ASPHALT CONCRETE."
8. No preparatory asphalt work shall be done when the atmospheric temperature is below 50 °F or during unsuitable weather.
9. Following the asphalt placement, the Contractor shall roll the entire area of new asphalt in both directions at least twice. The finished patch shall be level and smooth in compliance with 302-5.6.2 "Density and Smoothness." After placement and compaction of the asphalt patch, the Contractor shall seal all finished edges with a 4" wide continuous band of SS-1H.
10. The minimum dimension for each individual repair shall be 4' x 4' and shall be subject to the following conditions:
 - a) If the base material is exposed to achieve the required minimum removal thickness, the base material shall be prepared conforming to 301-1, "SUBGRADE PREPARATION."
 - b) When additional base material is required, then the contractor shall use Class 2 Aggregate Base in accordance with 200-2.2, "Crushed Aggregate Base." Recycled base material shall conform to Crushed Miscellaneous Base Material in accordance with 200-2.4, "Crushed Miscellaneous Base."
 - c) The Contractor may use grinding as a method for removal of deteriorated pavement when the areas indicated for removal are large enough (a minimum of the machine drum width) and when approved by the Engineer.
 - d) For both scheduled and unscheduled base repairs, failed areas may be removed by milling or by excavation provided that the edges are cut cleanly with a saw. The areas shall be cleaned and tack coated in accordance with 302-5.4, "Tack Coat" before replacing the asphalt. The areas for scheduled repairs have been marked on the street.

302-3.1 Asphalt Patching.

1. Asphalt patching shall consist of patching potholes, gutter-line erosion, and other low spots in the pavement that are deeper than ½" per 302-5.6.2, "Density and Smoothness." These areas are generally smaller and more isolated than those areas in need of mill and pave.
2. The areas requiring patching have been identified in the Contract Documents, marked on the streets, or as directed by the Engineer. The Contractor shall identify any new areas that may require patching prior to slurry work to ensure the smoothness and quality of the finished product.
3. The Contractor shall identify and repair any areas that may require patching, prior to the placement of slurry seal for smooth finished product.

4. Asphalt overlay shall not be applied over deteriorated pavement. Preparatory asphalt work shall be completed and approved by the Engineer before proceeding with asphalt overlay.
5. The Contractor shall remove distressed asphalt pavement either by saw cutting or milling, to expose firm and unyielding pavement; prepare subgrade (as needed); and install compacted asphalt concrete pavement over compacted native material as directed by the Engineer.
6. Prior to replacing asphalt, the area shall be cleaned and tack coated per 302-5.4, "Tack Coat".
7. Following the asphalt placement, the Contractor shall roll the entire patch in both directions covering the patch at least twice.
8. After placement and compaction of the asphalt patch, the Contractor shall seal all finished edges with a 4" wide continuous band of SS-1H.
9. Base repairs shall not exceed 20% RAP in content.

302-3.2 Payment.

1. Payment for replacement of existing pavement when required shall be included in the unit bid price for Asphalt Pavement repair for the total area replaced and no additional payment shall be made regardless of the number of replacements completed. No payment shall be made for areas of over excavation or outside trench areas in utility works unless previously approved by the Engineer. No payment for pavement replacement will be made when the damage is due to the Contractor's failure to protect existing improvements. The Contractor shall reimburse the City for the cost of retesting all failing compaction tests.
2. The areas and quantities shown on the road segments and in appendices are given only for the Contractor's aid in planning the Work and preparing Bids. The Engineer will designate the limits to be removed and these designated areas shall be considered to take precedent over the area shown in an Appendix to the Contract Documents. The quantities shown in the appendices are based on a street assessment survey and may vary.
3. At the end of each day, the Contractor shall submit to the Engineer an itemized list of the asphalt pavement repair work completed. The list shall include the location of the work and the exact square footage of the repair.
4. Preparatory repair work and tack coating will be paid at the Contract unit price per ton for Asphalt Pavement Repair. No payment shall be made for areas of over excavation unless previously approved by the Engineer.
5. Milling shall be included in the Bid item for Asphalt Pavement Repair unless separate Bid item has been provided.
6. Payment for miscellaneous asphalt patching shall be included in the Contract unit price for slurry and no additional payment shall be made therefore.

302-5.1.1 Damaged AC Pavement Replacement. To the City Supplement, DELETE in its entirety.

302-5.1.2 Measurement and Payment. To the City Supplement, DELETE in its entirety.

302-5.5 Distribution and Spreading. To the City Supplement, ADD the following:

19. Overlays of existing asphalt concrete that has been cold milled shall be a minimum of 2” in depth on average and per the elevations shown on the plans.

302-6.7 Traffic and Use Provisions. DELETE Paragraphs 2 and 3 and SUBSTITUTE with the following:

For properties with only one driveway and whose driveway cannot be constructed in phases to allow continuous access, modifications to City of San Diego Standard Drawing SDG-159 Concrete Driveway (Contiguous Sidewalk) will include deleting 560-C-3250. Contractor shall determine the concrete mix design based on the minimum compressive strength of 3250 psi within 24 hours.

Pavement constructed of concrete which has been treated in accordance with 201-1 to obtain an early increase in strength may be opened to traffic 1 day after it is placed.

At least 1 day shall elapse from the time the concrete is placed before any mechanical tamper, spreader, or finisher which will be supported by the edge of the new pavement, may be operated in adjacent lanes.

SECTION 303 – CONCRETE AND MASONRY CONSTRUCTION

ADD:

303-1.12 Trench Drain and Cover Grates.

303-1.12.1 General. Trench drains shall be constructed in accordance with 303-1. Grates and frames for the trench drain system shall be installed in accordance with manufacturer's instructions and recommendations. The frames and grates shall be installed such that the grate is firmly seated into the frame without rocking or protruding edges.

The frames shall be secured during construction of the trench drain in such a manner that the installed grate will be flush with the adjacent curb surface.

Cover Grates shall be R-4999 FX – Type D, manufactured by Neenah Foundry, or an approved equal.

303-1.12.2 Measurement and Payment. Trench Drain and Cover Grates will be paid for per Linear Feet, and shall include full compensation for furnishing all labor, materials, equipment, tools and incidentals and for the concrete trench drain, trench covers, and trench frames, complete in place, as specified in these Specifications, as shown on the Plans, and as directed by the City Engineer.

303-5.5.3 Walk. To the City Supplement, ADD the following:

6. Expansion, control, and scoring joints shall be per the details shown on the plans.

ADD:

303-5.5.3.1 Decorative Emblems. Decorative Emblems shall be cast brass plaque with Golden Hill logo as detailed on the plans and approved by the Engineer.

Contractor shall provide shop drawings illustrating methods of construction for approval prior to fabrication.

Fabrication of emblem is available through “The Sign Place”, Tel: 805-781-2091.

ADD:

303-5.5.3.2 Measurement and Payment. Decorative Emblems shall be paid for at the contract unit price for Each, and shall include full compensation for furnishing all labor, materials, tools, equipment, and incidentals, and for doing all the work involved in Decorative Emblems, complete, in place, as shown on the plans and per these Special Provisions.

303-5.5.5 Alley Intersections, Access Ramps, and Driveways. To the City Supplement, ADD the following:

Expansion, control, and scoring joints shall be per the details shown on the plans.

303-5.9 Measurement and Payment. To the City Supplement, ADD the following:

7. The contract unit price for PCC Sidewalk shall include doing all the work involved in the expansion, control, and scoring joints as details on the Plans.

ADD:

303-9 INTERLOCKING CONCRETE PAVERS.

303-9.1 General. Contractor shall submit two samples of each color to the City for approval prior to installation. Provide cut-sheets for available color & size options, and a list of manufacturers.

Interlocking Concrete Pavers:

Acceptable Manufacturer: Wausau Tile Co., P. O. Box 1520 9001 Bus Hwy. 51; Wausau, WI 54402-1520; Toll Free Tel: 800-388-8728; Tel: 715-359-3121; Email: request info (wtile@wausautile.com.); Web: www.wausautile.com

Model: Plank Pavers

Size: 3”x12” (75%), 3”x24” (25%)

Pattern: Random as approved.

Color: Dark Brown (20%), Tan (30%), Gray (30%), Gray Black (20%)

Example photograph of style to be provided upon request.

Or approved equal.

Installation Materials:

Base: Sub-base aggregate shall conform with Section 301

Bedding Sand: Clean Washed Concrete Bedding Sand

Jointing Sand: Alliance Gator XP Polymeric Sand

Filter Fabric: Woven or non-woven non-biodegradable filter between the compacted base and the sand leveling bed.

Installation:

Mockup: Provide a sample mockup installation in one of the areas to receive pavers within the project. This mockup will be subject for approval by the City. The mockup may be used in the final installation if approved.

Install in accordance with manufacturer's instructions.

Placement Tolerance:

Maximum of 1/16 inch (1.6 mm) height variation between adjacent pavers.

Individual pavers shall not vary more than 1/16 inch (1.6 mm) from level across width of the paver.

Paved areas shall not vary more than 1/4 inch (6 mm) from level in a distance of 10 feet (3 m) measured at any location and in any direction.

Joints between pavers to be 3/16 inch (4.8 mm) or 1/8 inch (3 mm).

303-9.2 Measurement and Payment. Interlocking Concrete Pavers shall be paid for at the contract unit price per Square Foot, and shall include full compensation for furnishing all labor, materials, tools, equipment, and incidentals, and for doing all the work involved in Interlocking Concrete Pavers, complete, in place, as shown on the plans and per these Special Provisions.

SECTION 306 – UNDERGROUND CONDUIT CONSTRUCTION

306-1 OPEN TRENCH OPERATIONS. To the City Supplement, CORRECT certain section numbering as follows:

OLD SECTION NUMBER	TITLE	NEW SECTION NUMBER
306-1.8	House Connection Sewer (Laterals) and Cleanouts	306-1.9
306-1.7.1	Payment	306-1.9.1
306-1.7.2	Sewer Lateral with Private Replumbing	306-1.9.2
306-1.7.2.1	location	306-1.9.2-1
306-1.7.2.2	Permits	306-1.9.2-2
306-1.7.2.3	Submittals	306-1.9.2-3
306-1.7.2.4	Trenchless Construction	306-1.9.2-4
306-1.7.2.5	Payment	306-1.9.2-5
306-1.7.3.6	Private Pump Installation	306-1.9.2-6
306-1.7.3.7	Payment	306-1.9.2-7

306-1.1.1 General. ADD the following:

Build the Project in accordance with the water high lining phasing shown on the Plans and in phase as follows:

Phase I: 25th Street from B to E Street

306-1.6 Basis of Payment for Open Trench Installations. ADD the following:

Payment for imported backfill when the Contractor elects to import material from a source outside the project limits and when authorized by the Engineer shall be included in the Bid unit price for Imported Backfill. The price shall include the removal and disposal of unsuitable materials.

306-5.3 Payment. To the City Supplement, ADD the following:

7. Payment for removing and capping abandoned water meter boxes outside the proposed trench zone shall be included in the Bid items for remove and cap abandoned water meter boxes.

306-22 Pipe Fusion. DELETE in its entirety.

SECTION 314 – TRAFFIC STRIPING, CURB AND PAVEMENT MARKINGS, AND PAVEMENT MARKERS

314-4.3.1 General. ADD the following:

Traffic striping and pavement marking shall conform to Section 84, and to the Standard Plans, State of California, Drawing No. A20 A, B, C, and D; and to A24 A, B, C, D, and E.

The paint shall be rapid dry water-borne (State Spec. No. 8010-19D-30).

314-4.4.1 General. ADD the following:

Pedestrian crosswalks, limit lines, pavement arrows, and pavement legends (except within a bike lane) shall be installed utilizing thermoplastic marking material.

314-5.2.1 General. ADD the following:

Raised Reflective pavement markers shall conform to Section 85 of the California Standard Specifications.

Pavement markers shall be installed where indicated on the plans on all lane lines and centerline striping on all new streets, as well as on existing streets where replacement of pavement markers is necessary. The minimum height of the pavement markers shall be 18 mm (0.70”).

SECTION 600 – WORK INVOLVING THE CITY FORCES

600-1.2.1.2 High-lining Removed by the Contractor. To the City Supplement, DELETE the first paragraph (a), and SUBSTITUTE with the following:

When directed by the Engineer the Contractor shall transfer the water services and remove the high-line materials. The Contractor will pickup and deliver all the City high-line materials to Water Operations Division at: Chollas Station, 2797 Caminito Chollas, San Diego, CA 92105

600-1.2.1.3 Payment, To the City Supplement, DELETE the 3rd paragraph (c), and SUBSTITUTE with the following:

If high-lining by Contractor is awarded under “Additive Alternate”, payment for high-lining removal and water service transfers by Contractor shall be included in the unit bid price for “High-lining Installation and Dismantling by the Contractor”. Otherwise, if City Forces install the high-line system and the Contractor is requested to transfer the water services, remove the high-line and deliver to the City designated location, payment shall then be made in accordance with the unit bid price for “High-lining Removed by Contractor” and “Water Service Transfer from High-line” in the base bid.

SECTION 701 – WATER POLLUTION CONTROL

ADD:

701-2.9.1 Storm Water Treatment Basins. Storm Water Treatment Basins shall be installed per the manufacturer’s recommendations, in conformance with the Standard and Whitebook Specifications, and per the plans and these special provisions.

Acceptable Products:

Curb Inlet Treatment Basins:

2 each Biofilter Inline, Model UGBF0612, 42” Depth, manufactured by Contech Construction Products Inc., Phone: 1-800-526-3999.

Storage Tanks:

32 total Triple units manufactured by EcoRain Systems, Phone 818-905-7145, and installed per the details shown on the plans and per the manufacturer's recommendations.

Preparation of the subgrade shall be per the manufacturer's recommendations.

The gravel used for the bedding material of the infiltration basin shall be ¾" in conformance with Section 200 of the Standard Specifications.

The Contractor's attention is directed to the recommendations of the manufacturer concerning unloading requirements and basic installation requirements.

701-11 Post-Construction Requirements. To the City Supplement, ADD the following:

5. Comply with the following post-construction requirements:

- **Storm Water Treatment Basins**

701-13.8.4 Payment. ADD the following:

4. Payment for the storm water treatment basins shall be included in the contract unit price of each "Storm Water Treatment Basins," and shall include full compensation for furnishing all labor, materials, tools, equipment, and incidentals, and for doing all the work involved to install storm water treatment basins (including, but not limited to, Contech Biofilter Inline, EcoRain storage tanks, piping, and bedding material), complete in place, as shown on the plans and per these Special Provisions.

SECTION 705 – WATER DISCHARGES

705-2.6.1 General. Paragraph (3), CORRECT reference to Section 803 to read "Section 703."

705-2.6.3 Community Health and Safety Plan. To the City Supplement, DELETE in its entirety and SUBSTITUTE with the following:

705-2.6.3 Community Health and Safety Plan. See 703-2, "Community Health and Safety Plan."

SECTION 707 – RESOURCE DISCOVERIES

ADD:

707-1.1 Environmental Document. The City of San Diego Environmental Analysis Section (EAS) of the Development Services Department has prepared a Notice of Exemption for 25th Street Renaissance, Project No. WBS No. S-00985, as referenced in the Contract Appendix. You must comply with all requirements of the Notice of Exemption as set forth in the Contract Appendix

Compliance with the City's environmental document is included in the various Bid items, unless a bid item has been provided.

END OF SUPPLEMENTARY SPECIAL PROVISIONS (SSP)

SUPPLEMENTARY SPECIAL PROVISIONS

APPENDICES

APPENDIX A
NOTICE OF EXEMPTION

NOTICE OF EXEMPTION

(Check one or both)

TO: RECORDER/COUNTY CLERK
P.O. BOX 1750, MS A-33
1600 PACIFIC HWY, ROOM 260
SAN DIEGO, CA 92101-2422

FROM: CITY OF SAN DIEGO
DEVELOPMENT SERVICES DEPARTMENT
1222 FIRST AVENUE, MS 501
SAN DIEGO, CA 92101

OFFICE OF PLANNING AND RESEARCH
1400 TENTH STREET, ROOM 121
SACRAMENTO, CA 95814

PROJECT NO.: WBS No. S-00985

PROJECT TITLE: 25TH STREET RENAISSANCE

PROJECT LOCATION-SPECIFIC: The project is located within the existing public right-of-way along 25th St., between Golden Hill Dr. and SR-94, within the Greater Golden Hill Community Planning Area.

PROJECT LOCATION-CITY/COUNTY: San Diego/San Diego

DESCRIPTION OF NATURE AND PURPOSE OF THE PROJECT: The proposed street improvement project would widen and restripe 25th Street in order to improve traffic movement, accommodate a new Class II bicycle lane, provide increased on-street parking, provide landscaped parkways, and install ADA-compliant bulb-outs at all street corners. Approximately 82 new street trees would be installed to complement the existing 110 street trees. The new street trees would conform to the Greater Golden Hill Community Plan, which calls for palm trees lining the street and Jacaranda trees lining the sidewalks. Any encountered historic sidewalk stamps or railroad tracks would be preserved per City standards (SDG-115) and Greenbook specifications. The Geotracker hazardous materials database shows several closed cases within the project vicinity. City Environmental Services staff has confirmed that no adverse impacts would result from the proposed project. All proposed work would occur within the public right-of-way. From B Street to Broadway, both sides would be widened by 2.5 feet, and existing sidewalks would be replaced with new 17.5-foot sidewalks, curb, and gutter. The street would be restriped from four travel lanes to two travel lanes with a middle left-turn lane. A project-specific traffic study concludes that no adverse impacts to operational levels of service would result from the proposed project. The west side of the street, between B Street and Broadway, would include seven-foot-wide parallel parking, five-foot-wide Class II bike lane, and an 11-foot-wide southbound travel lane adjacent to the ten-foot-wide center left-turn lane. The east side of the street, between B Street and Broadway, would include 16-foot-deep angled back-in parking, five-foot-wide Class II bike lane, and an 11-foot-wide northbound travel lane. From Broadway to E Street, the project would replace existing four- to five-foot-wide sidewalks with new eight-foot-wide sidewalks, and reduce the width of existing parkway accordingly. Seven-foot-wide parallel parking, five-foot-wide Class II bike lanes, 11-foot-wide travel lanes, and a center left-turn lane will also be provided. From E Street to F Street, the project would widen the existing sidewalks from five feet to eight feet and replace street lights to be consistent with the Golden Hill Community Plan and community input. From B Street to Russ Street, the project would widen the existing sidewalks from five feet to eight feet, extend curb and gutter out by 6.5 feet, narrow the street and widen the parkway. Street lights consistent with Golden Hill Community Plan and community input would be installed. A new turn-around at the intersection of 25th Street and Golden Hill Drive would continue to allow traffic in to and out of Balboa Park and facilitate turn-around movements when the park entry gates are closed each evening. A water line that extends from B Street, south to Street would be replaced in place.

NAME OF PUBLIC AGENCY APPROVING PROJECT: City of San Diego

NAME OF PERSON OR AGENCY CARRYING OUT PROJECT: City of San Diego, Engineering & Capital Projects Department
David Li, Project Engineer
600 B Street, MS 908A
San Diego, CA 92101
(619) 533-5164

EXEMPT STATUS: CATEGORICAL EXEMPTION: 15301 (EXISTING FACILITIES) & 15302 (REPLACEMENT OR RECONSTRUCTION)

REASONS WHY PROJECT IS EXEMPT: The City of San Diego conducted an Initial Study which determined that this project meets the criteria set forth in CEQA Section 15301 which allows for the repair, maintenance, or minor alteration of existing public facilities, including streets, sidewalks, gutters and CEQA Section 15302 which allows for replacement or reconstruction of existing facilities involving negligible or no expansion of capacity, and where exceptions listed in CEQA Section 15300.4 would not apply. Records and subsequent investigations have shown the existence of railroad tracks buried under 25th Street for a two block section, from Broadway to B Street. Although these track sections have been removed by public improvements over the years, the San Diego trolley's beginnings, expansion, demise and more recent resurgence are well-documented by the San Diego History Center, major local universities, San Diego Transit engineering drawings, and by publications such as the 1960 book, "Rails of the Silver Gate," by Richard V. Dodge and the "San Diego & Arizona, The Impossible Railroad (1984), by Robert Hanft. Any encountered railroad tracks would be removed and properly disposed of per Greenbook per Section 800-1.9.2. No impacts to historical resources are anticipated.

Revised 010410mjh

LEAD AGENCY CONTACT PERSON: Myra Herrmann

TELEPHONE: (619) 446-5372

IF FILED BY APPLICANT:

- 1. ATTACH CERTIFIED DOCUMENT OF EXEMPTION FINDING.
- 2. HAS A NOTICE OF EXEMPTION BEEN FILED BY THE PUBLIC AGENCY APPROVING THE PROJECT? () YES () NO

IT IS HEREBY CERTIFIED THAT THE CITY OF SAN DIEGO HAS DETERMINED THE ABOVE ACTIVITY TO BE EXEMPT FROM CEQA

 SENIOR PLANNER

 SIGNATURE/TITLE

July 22, 2011

 DATE

CHECK ONE:

- (X) SIGNED BY LEAD AGENCY
- () SIGNED BY APPLICANT

DATE RECEIVED FOR FILING WITH COUNTY CLERK OR OPR:

APPENDIX B
FIRE HYDRANT METER PROGRAM

CITY OF SAN DIEGO CALIFORNIA DEPARTMENT INSTRUCTIONS	NUMBER DI 55.27	DEPARTMENT Water Department
SUBJECT FIRE HYDRANT METER PROGRAM (FORMERLY: CONSTRUCTION METER PROGRAM)	PAGE 1 OF 10	EFFECTIVE DATE October 15, 2002
	SUPERSEDES DI 55.27	DATED April 21, 2000

1. **PURPOSE**

1.1 To establish a Departmental policy and procedure for issuance, proper usage and charges for fire hydrant meters.

2. **AUTHORITY**

2.1 All authorities and references shall be current versions and revisions.

2.2 San Diego Municipal Code (NC) Chapter VI, Article 7, Sections 67.14 and 67.15

2.3 Code of Federal Regulations, Safe Drinking Water Act of 1986

2.4 California Code of Regulations, Titles 17 and 22

2.5 California State Penal Code, Section 498B.0

2.6 State of California Water Code, Section 110, 500-6, and 520-23

2.7 Water Department Director

Reference

2.8 State of California Guidance Manual for Cross Connection Programs

2.9 American Water Works Association Manual M-14, Recommended Practice for Backflow Prevention

2.10 American Water Works Association Standards for Water Meters

2.11 U.S.C. Foundation for Cross Connection Control and Hydraulic Research Manual

3. **DEFINITIONS**

3.1 **Fire Hydrant Meter:** A portable water meter which is connected to a fire hydrant for the purpose of temporary use. (These meters are sometimes referred to as Construction Meters.)

CITY OF SAN DIEGO CALIFORNIA DEPARTMENT INSTRUCTIONS	NUMBER DI 55.27	DEPARTMENT Water Department
SUBJECT FIRE HYDRANT METER PROGRAM (FORMERLY: CONSTRUCTION METER PROGRAM)	PAGE 2 OF 10	EFFECTIVE DATE October 15, 2002
	SUPERSEDES DI 55.27	DATED April 21, 2000

- 3.2 **Temporary Water Use:** Water provided to the customer for no longer than twelve (12) months.
- 3.3 **Backflow Preventor:** A Reduced Pressure Principal Assembly connected to the outlet side of a Fire Hydrant Meter.

4. **POLICY**

- 4.1 The Water Department shall collect a deposit from every customer requiring a fire hydrant meter and appurtenances prior to providing the meter and appurtenances (see Section 7.1 regarding the Fees and Deposit Schedule). The deposit is refundable upon the termination of use and return of equipment and appurtenances in good working condition.
- 4.2 Fire hydrant meters will have a 2 ½" swivel connection between the meter and fire hydrant. The meter shall not be connected to the 4" port on the hydrant. All Fire Hydrant Meters issued shall have a Reduced Pressure Principle Assembly (RP) as part of the installation. Spanner wrenches are the only tool allowed to turn on water at the fire hydrant.
- 4.3 The use of private hydrant meters on City hydrants is prohibited, with exceptions as noted below. All private fire hydrant meters are to be phased out of the City of San Diego. All customers who wish to continue to use their own fire hydrant meters must adhere to the following conditions:
 - a. Meters shall meet all City specifications and American Water Works Association (AWWA) standards.
 - b. Customers currently using private fire hydrant meters in the City of San Diego water system will be allowed to continue using the meter under the following conditions:
 - 1. The customer must submit a current certificate of accuracy and calibration results for private meters and private backflows annually to the City of San Diego, Water Department, Meter Shop.

CITY OF SAN DIEGO CALIFORNIA DEPARTMENT INSTRUCTIONS	NUMBER DI 55.27	DEPARTMENT Water Department
SUBJECT FIRE HYDRANT METER PROGRAM (FORMERLY: CONSTRUCTION METER PROGRAM)	PAGE 3 OF 10	EFFECTIVE DATE October 15, 2002
	SUPERSEDES DI 55.27	DATED April 21, 2000

2. The meter must be properly identifiable with a clearly labeled serial number on the body of the fire hydrant meter. The serial number shall be plainly stamped on the register lid and the main casing. Serial numbers shall be visible from the top of the meter casing and the numbers shall be stamped on the top of the inlet casing flange.
3. All meters shall be locked to the fire hydrant by the Water Department, Meter Section (see Section 4.7).
4. All meters shall be read by the Water Department, Meter Section (see Section 4.7).
5. All meters shall be relocated by the Water Department, Meter Section (see Section 4.7).
6. These meters shall be tested on the anniversary of the original test date and proof of testing will be submitted to the Water Department, Meter Shop, on a yearly basis. If not tested, the meter will not be allowed for use in the City of San Diego.
7. All private fire hydrant meters shall have backflow devices attached when installed.
8. The customer must maintain and repair their own private meters and private backflows.
9. The customer must provide current test and calibration results to the Water Department, Meter Shop after any repairs.
10. When private meters are damaged beyond repair, these private meters will be replaced by City owned fire hydrant meters.

CITY OF SAN DIEGO CALIFORNIA DEPARTMENT INSTRUCTIONS	NUMBER DI 55.27	DEPARTMENT Water Department
SUBJECT FIRE HYDRANT METER PROGRAM (FORMERLY: CONSTRUCTION METER PROGRAM)	PAGE 4 OF 10	EFFECTIVE DATE October 15, 2002
	SUPERSEDES DI 55.27	DATED April 21, 2000

11. When a private meter malfunctions, the customer will be notified and the meter will be removed by the City and returned to the customer for repairs. Testing and calibration results shall be given to the City prior to any re-installation.
 12. The register shall be hermetically sealed straight reading and shall be readable from the inlet side. Registration shall be in hundred cubic feet.
 13. The outlet shall have a 2 ½ “National Standards Tested (NST) fire hydrant male coupling.
 14. Private fire hydrant meters shall not be transferable from one contracting company to another (i.e. if a company goes out of business or is bought out by another company).
- 4.4 All fire hydrant meters and appurtenances shall be installed, relocated and removed by the City of San Diego, Water Department. All City owned fire hydrant meters and appurtenances shall be maintained by the City of San Diego, Water Department, Meter Services.
- 4.5 If any fire hydrant meter is used in violation of this Department Instruction, the violation will be reported to the Code Compliance Section for investigation and appropriate action. Any customer using a fire hydrant meter in violation of the requirements set forth above is subject to fines or penalties pursuant to the Municipal Code, Section 67.15 and Section 67.37.

4.6 Conditions and Processes for Issuance of a Fire Hydrant Meter

Process for Issuance

- a. Fire hydrant meters shall only be used for the following purposes:
 1. Temporary irrigation purposes not to exceed one year.

CITY OF SAN DIEGO CALIFORNIA DEPARTMENT INSTRUCTIONS	NUMBER DI 55.27	DEPARTMENT Water Department
SUBJECT FIRE HYDRANT METER PROGRAM (FORMERLY: CONSTRUCTION METER PROGRAM)	PAGE 5 OF 10	EFFECTIVE DATE October 15, 2002
	SUPERSEDES DI 55.27	DATED April 21, 2000

2. Construction and maintenance related activities (see Tab 2).
 - b. No customer inside or outside the boundaries of the City of San Diego Water Department shall resell any portion of the water delivered through a fire hydrant by the City of San Diego Water Department.
 - c. The City of San Diego allows for the issuance of a temporary fire hydrant meter for a period not to exceed 12 months (365 days). An extension can only be granted in writing from the Water Department Director for up to 90 additional days. A written request for an extension by the consumer must be submitted at least 30 days prior to the 12 month period ending. No extension shall be granted to any customer with a delinquent account with the Water Department. No further extensions shall be granted.
 - d. Any customer requesting the issuance of a fire hydrant meter shall file an application with the Meter Section. The customer must complete a "Fire Hydrant Meter Application" (Tab 1) which includes the name of the company, the party responsible for payment, Social Security number and/or California ID, requested location of the meter (a detailed map signifying an exact location), local contact person, local phone number, a contractor's license (or a business license), description of specific water use, duration of use at the site and full name and address of the person responsible for payment.
 - e. At the time of the application the customer will pay their fees according to the schedule set forth in the Rate Book of Fees and Charges, located in the City Clerk's Office. All fees must be paid by check, money order or cashiers check, made payable to the City Treasurer. Cash will not be accepted.
 - f. No fire hydrant meters shall be furnished or relocated for any customer with a delinquent account with the Water Department.
 - g. After the fees have been paid and an account has been created, the

CITY OF SAN DIEGO CALIFORNIA DEPARTMENT INSTRUCTIONS	NUMBER DI 55.27	DEPARTMENT Water Department
SUBJECT FIRE HYDRANT METER PROGRAM (FORMERLY: CONSTRUCTION METER PROGRAM)	PAGE 6 OF 10	EFFECTIVE DATE October 15, 2002
	SUPERSEDES DI 55.27	DATED April 21, 2000

meter shall be installed within 48 hours (by the second business day). For an additional fee, at overtime rates, meters can be installed within 24 hours (within one business day).

4.7 Relocation of Existing Fire Hydrant Meters

- a. The customer shall call the Fire Hydrant Meter Hotline (herein referred to as “Hotline”), a minimum of 24 hours in advance, to request the relocation of a meter. A fee will be charged to the existing account, which must be current before a work order is generated for the meter’s relocation.
- b. The customer will supply in writing the address where the meter is to be relocated (map page, cross street, etc). The customer must update the original Fire Hydrant Meter Application with any changes as it applies to the new location.
- c. Fire hydrant meters shall be read on a monthly basis. While fire hydrant meters and backflow devices are in service, commodity, base fee and damage charges, if applicable, will be billed to the customer on a monthly basis. If the account becomes delinquent, the meter will be removed.

4.8 Disconnection of Fire Hydrant Meter

- a. After ten (10) months a “Notice of Discontinuation of Service” (Tab 3) will be issued to the site and the address of record to notify the customer of the date of discontinuance of service. An extension can only be granted in writing from the Water Department Director for up to 90 additional days (as stated in Section 4.6C) and a copy of the extension shall be forwarded to the Meter Shop Supervisor. If an extension has not been approved, the meter will be removed after twelve (12) months of use.
- b. Upon completion of the project the customer will notify the Meter Services office via the Hotline to request the removal of the fire hydrant meter and appurtenances. A work order will be generated

CITY OF SAN DIEGO CALIFORNIA DEPARTMENT INSTRUCTIONS	NUMBER DI 55.27	DEPARTMENT Water Department
SUBJECT FIRE HYDRANT METER PROGRAM (FORMERLY: CONSTRUCTION METER PROGRAM)	PAGE 7 OF 10	EFFECTIVE DATE October 15, 2002
	SUPERSEDES DI 55.27	DATED April 21, 2000

for removal of the meter.

- c. Meter Section staff will remove the meter and backflow prevention assembly and return it to the Meter Shop. Once returned to the Meter Shop the meter and backflow will be tested for accuracy and functionality.
- d. Meter Section Staff will contact and notify Customer Services of the final read and any charges resulting from damages to the meter and backflow or its appurtenance. These charges will be added on the customer's final bill and will be sent to the address of record. Any customer who has an outstanding balance will not receive additional meters.
- e. Outstanding balances due may be deducted from deposits and any balances refunded to the customer. Any outstanding balances will be turned over to the City Treasurer for collection. Outstanding balances may also be transferred to any other existing accounts.

5. **EXCEPTIONS**

- 5.1 Any request for exceptions to this policy shall be presented, in writing, to the Customer Support Deputy Director, or his/her designee for consideration.

6. **MOBILE METER**

- 6.1 Mobile meters will be allowed on a case by case basis. All mobile meters will be protected by an approved backflow assembly and the minimum requirement will be a Reduced Pressure Principal Assembly. The two types of Mobile Meters are vehicle mounted and floating meters. Each style of meters has separate guidelines that shall be followed for the customer to retain service and are described below:

- a) **Vehicle Mounted Meters:** Customer applies for and receives a City owned Fire Hydrant Meter from the Meter Shop. The customer mounts the meter on the vehicle and brings it to the Meter Shop for

CITY OF SAN DIEGO CALIFORNIA DEPARTMENT INSTRUCTIONS	NUMBER DI 55.27	DEPARTMENT Water Department
SUBJECT FIRE HYDRANT METER PROGRAM (FORMERLY: CONSTRUCTION METER PROGRAM)	PAGE 8 OF 10	EFFECTIVE DATE October 15, 2002
	SUPERSEDES DI 55.27	DATED April 21, 2000

inspection. After installation is approved by the Meter Shop the vehicle and meter shall be brought to the Meter Shop on a monthly basis for meter reading and on a quarterly basis for testing of the backflow assembly. Meters mounted at the owner's expense shall have the one year contract expiration waived and shall have meter or backflow changed if either fails.

b) **Floating Meters:** Floating Meters are meters that are not mounted to a vehicle. **(Note: All floating meters shall have an approved backflow assembly attached.)** The customer shall submit an application and a letter explaining the need for a floating meter to the Meter Shop. The Fire Hydrant Meter Administrator, after a thorough review of the needs of the customer, (i.e. number of jobsites per day, City contract work, lack of mounting area on work vehicle, etc.), may issue a floating meter. At the time of issue, it will be necessary for the customer to complete and sign the "Floating Fire Hydrant Meter Agreement" which states the following:

- 1) The meter will be brought to the Meter Shop at 2797 Caminito Chollas, San Diego on the third week of each month for the monthly read by Meter Shop personnel.
- 2) Every other month the meter will be read and the backflow will be tested. This date will be determined by the start date of the agreement.

If any of the conditions stated above are not met the Meter Shop has the right to cancel the contract for floating meter use and close the account associated with the meter. The Meter Shop will also exercise the right to refuse the issuance of another floating meter to the company in question.

Any Fire Hydrant Meter using reclaimed water shall not be allowed use again with any potable water supply. The customer shall incur the cost of replacing the meter and backflow device in this instance.

CITY OF SAN DIEGO CALIFORNIA DEPARTMENT INSTRUCTIONS	NUMBER DI 55.27	DEPARTMENT Water Department
SUBJECT FIRE HYDRANT METER PROGRAM (FORMERLY: CONSTRUCTION METER PROGRAM)	PAGE 9 OF 10	EFFECTIVE DATE October 15, 2002
	SUPERSEDES DI 55.27	DATED April 21, 2000

7. **FEE AND DEPOSIT SCHEDULES**

7.1 **Fees and Deposit Schedules:** The fees and deposits, as listed in the Rate Book of Fees and Charges, on file with the Office of the City Clerk, are based on actual reimbursement of costs of services performed, equipment and materials. These deposits and fees will be amended, as needed, based on actual costs. Deposits, will be refunded at the end of the use of the fire hydrant meter, upon return of equipment in good working condition and all outstanding balances on account are paid. Deposits can also be used to cover outstanding balances.

All fees for equipment, installation, testing, relocation and other costs related to this program are subject to change without prior notification. The Mayor and Council will be notified of any future changes.

8. **UNAUTHORIZED USE OF WATER FROM A HYDRANT**

8.1 Use of water from any fire hydrant without a properly issued and installed fire hydrant meter is theft of City property. Customers who use water for unauthorized purposes or without a City of San Diego issued meter will be prosecuted.

8.2 If any unauthorized connection, disconnection or relocation of a fire hydrant meter, or other connection device is made by anyone other than authorized Water Department personnel, the person making the connection will be prosecuted for a violation of San Diego Municipal Code, Section 67.15. In the case of a second offense, the customer's fire hydrant meter shall be confiscated and/or the deposit will be forfeited.

8.3 Unauthorized water use shall be billed to the responsible party. Water use charges shall be based on meter readings, or estimates when meter readings are not available.

8.4 In case of unauthorized water use, the customer shall be billed for all applicable charges as if proper authorization for the water use had been obtained, including but not limited to bi-monthly service charges, installation charges and removal charges.

CITY OF SAN DIEGO CALIFORNIA DEPARTMENT INSTRUCTIONS	NUMBER DI 55.27	DEPARTMENT Water Department
SUBJECT FIRE HYDRANT METER PROGRAM (FORMERLY: CONSTRUCTION METER PROGRAM)	PAGE 10 OF 10	EFFECTIVE DATE October 15, 2002
	SUPERSEDES DI 55.27	DATED April 21, 2000

- 8.5 If damage occurs to Water Department property (i.e. fire hydrant meter, backflow, various appurtenances), the cost of repairs or replacements will be charged to the customer of record (applicant).

**Larry Gardner
Water Department Director**

- Tabs: 1. Fire Hydrant Meter Application
2. Construction & Maintenance Related Activities With No Return To Sewer
3. Notice of Discontinuation of Service

APPENDIX

Administering Division: Customer Support Division

Subject Index: Construction Meters
Fire Hydrant
Fire Hydrant Meter Program
Meters, Floating or Vehicle Mounted
Mobile Meter
Program, Fire Hydrant Meter

Distribution: DI Manual Holders



Application for Fire Hydrant Meter (EXHIBIT A)

(For Office Use Only)

NS REQ	FAC#
DATE	BY

METER SHOP (619) 527-7449

Meter Information

Application Date	Requested Install Date:
------------------	-------------------------

Fire Hydrant Location: (Attach Detailed Map//Thomas Bros. Map Location or Construction drawing.) <u>Zip:</u>	<u>T.B.</u>	<u>G.B. (CITY USE)</u>
Specific Use of Water:		
Any Return to Sewer or Storm Drain, If so, explain:		
Estimated Duration of Meter Use: <input type="text"/>	<input type="checkbox"/>	Check Box if Reclaimed Water

Company Information

Company Name:			
Mailing Address:			
City:	State:	Zip:	Phone: ()
*Business license#		*Contractor license#	
A Copy of the Contractor's license OR Business License is required at the time of meter issuance.			
Name and Title of Billing Agent: <small>(PERSON IN ACCOUNTS PAYABLE)</small>			Phone: ()
Site Contact Name and Title:			Phone: ()
Responsible Party Name:			Title:
Cal ID#			Phone: ()
Signature:		Date:	
Guarantees Payment of all Charges Resulting from the use of this Meter. Insures that employees of this Organization understand the proper use of Fire Hydrant Meter			

Fire Hydrant Meter Removal Request	Requested Removal Date:
Provide Current Meter Location if Different from Above:	
Signature:	Title: Date:
Phone: ()	Pager: ()

<input type="checkbox"/>	City Meter	<input type="checkbox"/>	Private Meter
Contract Acct #:		Deposit Amount: \$ 936.00	Fees Amount: \$ 62.00
Meter Serial #		Meter Size: 05	Meter Make and Style: 6-7
Backflow #		Backflow Size:	Backflow Make and Style:
Name:		Signature:	Date:

WATER USES WITHOUT ANTICIPATED CHARGES FOR RETURN TO SEWER

Auto Detailing
Backfilling
Combination Cleaners (Vactors)
Compaction
Concrete Cutters
Construction Trailers
Cross Connection Testing
Dust Control
Flushing Water Mains
Hydro Blasting
Hydro Seeing
Irrigation (for establishing irrigation only; not continuing irrigation)
Mixing Concrete
Mobile Car Washing
Special Events
Street Sweeping
Water Tanks
Water Trucks
Window Washing

Note:

1. If there is any return to sewer or storm drain, then sewer and/or storm drain fees will be charges.

Date

Name of Responsible Party
Company Name and Address
Account Number: _____

Subject: Discontinuation of Fire Hydrant Meter Service

Dear Water Department Customer:

The authorization for use of Fire Hydrant Meter # _____, located at *(Meter Location Address)* ends in 60 days and will be removed on or after *(Date Authorization Expires)*. Extension requests for an additional 90 days must be submitted in writing for consideration 30 days prior to the discontinuation date. If you require an extension, please contact the Water Department, or mail your request for an extension to:

City of San Diego
Water Department
Attention: Meter Services
2797 Caminito Chollas
San Diego, CA 92105-5097

Should you have any questions regarding this matter, please call the Fire Hydrant Hotline at (619) _____ - _____.

Sincerely,

Water Department

APPENDIX C

MATERIALS TYPICALLY ACCEPTED BY CERTIFICATE OF COMPLIANCE

Materials Typically Accepted by Certificate of Compliance

1. Soil amendment
2. Fiber mulch
3. PVC or PE pipe up to 16 inch diameter
4. Stabilizing emulsion
5. Lime
6. Preformed elastomeric joint seal
7. Plain and fabric reinforced elastomeric bearing pads
8. Steel reinforced elastomeric bearing pads
9. Waterstops (Special Condition)
10. Epoxy coated bar reinforcement
11. Plain and reinforcing steel
12. Structural steel
13. Structural timber and lumber
14. Treated timber and lumber
15. Lumber and timber
16. Aluminum pipe and aluminum pipe arch
17. Corrugated steel pipe and corrugated steel pipe arch
18. Structural metal plate pipe arches and pipe arches
19. Perforated steel pipe
20. Aluminum underdrain pipe
21. Aluminum or steel entrance tapers, pipe downdrains, reducers, coupling bands and slip joints
22. Metal target plates
23. Paint (traffic striping)
24. Conductors
25. Painting of electrical equipment
26. Electrical components
27. Engineering fabric
28. Portland Cement
29. PCC admixtures
30. Minor concrete, asphalt
31. Asphalt (oil)
32. Liquid asphalt emulsion
33. Epoxy

APPENDIX D
SAMPLE CITY INVOICE

City of San Diego, Field Engineering Div., 9485 Aero Drive, SD CA 92123						Contractor's Name:					
Project Name:						Contractor's Address:					
SAP No. (WBS/IO/CC)											
City Purchase Order No.						Contractor's Phone #:			Invoice No.		
Resident Engineer (RE):						Contractor's Fax #:			Invoice Date:		
RE Phone#:			RE Fax#:			Contact Name:			Billing Period:		
Item #	Item Description	Contract Authorization				Previous Estimate		This Estimate		Totals to Date	
		Unit	Qty	Price	Extension	%/QTY	Amount	% / QTY	Amount	% / QTY	Amount
1	2 Parallel 4" PVC C900	LF	1,380	\$34.00	\$46,920.00						
2	48" Primary Steel Casing	LF	500	\$1,000.00	\$500,000.00						
3	2 Parallel 12" Secondary Steel	LF	1,120	\$53.00	\$59,360.00						
4	Construction and Rehab of PS 49	LS	1	\$150,000.00	\$150,000.00						
5	Demo	LS	1	\$14,000.00	\$14,000.00						
6	Install 6' High Chain Link Fence	LS	1	\$5,600.00	\$5,600.00						
7	General Site Restoration	LS	1	\$3,700.00	\$3,700.00						
8	10" Gravity Sewer	LF	10	\$292.00	\$2,920.00						
9	4" Blow Off Valves	EA	2	\$9,800.00	\$19,600.00						
10	Bonds	LS	1	\$16,000.00	\$16,000.00						
11	Field Orders	AL	1	80,000	\$80,000.00						
11.1	Field Order 1	LS	5,500	\$1.00	\$5,500.00						
11.2	Field Order 2	LS	7,500	\$1.00	\$7,500.00						
11.3	Field Order 3	LS	10,000	\$1.00	\$10,000.00						
11.4	Field Order 4	LS	6,500	\$1.00	\$6,500.00						
12	Certified Payroll	LS	1	\$1,400.00	\$1,400.00						
CHANGE ORDERS											
Change Order 1			4,890								
Items 1-4					\$11,250.00						
Item 5-Deduct Bid Item 3		LF	120	-\$53.00	(\$6,360.00)						
Change Order 2			160,480								
Items 1-3					\$95,000.00						
Item 4 Deduct Bid Item 1		LF	380	-\$340.00	(\$12,920.00)						
Item 5-Encrease bid Item 9		LF	8	\$9,800.00	\$78,400.00						
Change Order 3 (Close Out)			-121,500								
Item 1 Deduct Bid Item 3			53	-500.00	(\$26,500.00)						
Item 2 Deduct Bid Item 4		LS	-1	45,000.00	(\$45,000.00)						
Items 3-9			1	-50,500.00	(\$50,500.00)						
SUMMARY								Total This	\$ -	Total Billed	\$0.00
A. Original Contract Amount						Retention and/or Escrow Payment Schedule					
B. Approved Change Order 1 Thru 3						Total Retention Required as of this billing					
C. Total Authorized Amount (A+B)						Previous Retention Withheld in PO or in Escrow					
D. Total Billed to Date						Add'l Amt to Withhold in PO/Transfer in Escrow:					
E. Less Total Retention (5% of D)						Amt to Release to Contractor from PO/Escrow:					
F. Less Total Previous Payments											
G. Payment Due Less Retention						Contractor Signature and Date:					
H. Remaining Authorized Amount											

APPENDIX E
LOCATION MAP

25TH STREET RENAISSANCE / GROUP JOB 960



Right of Way Design

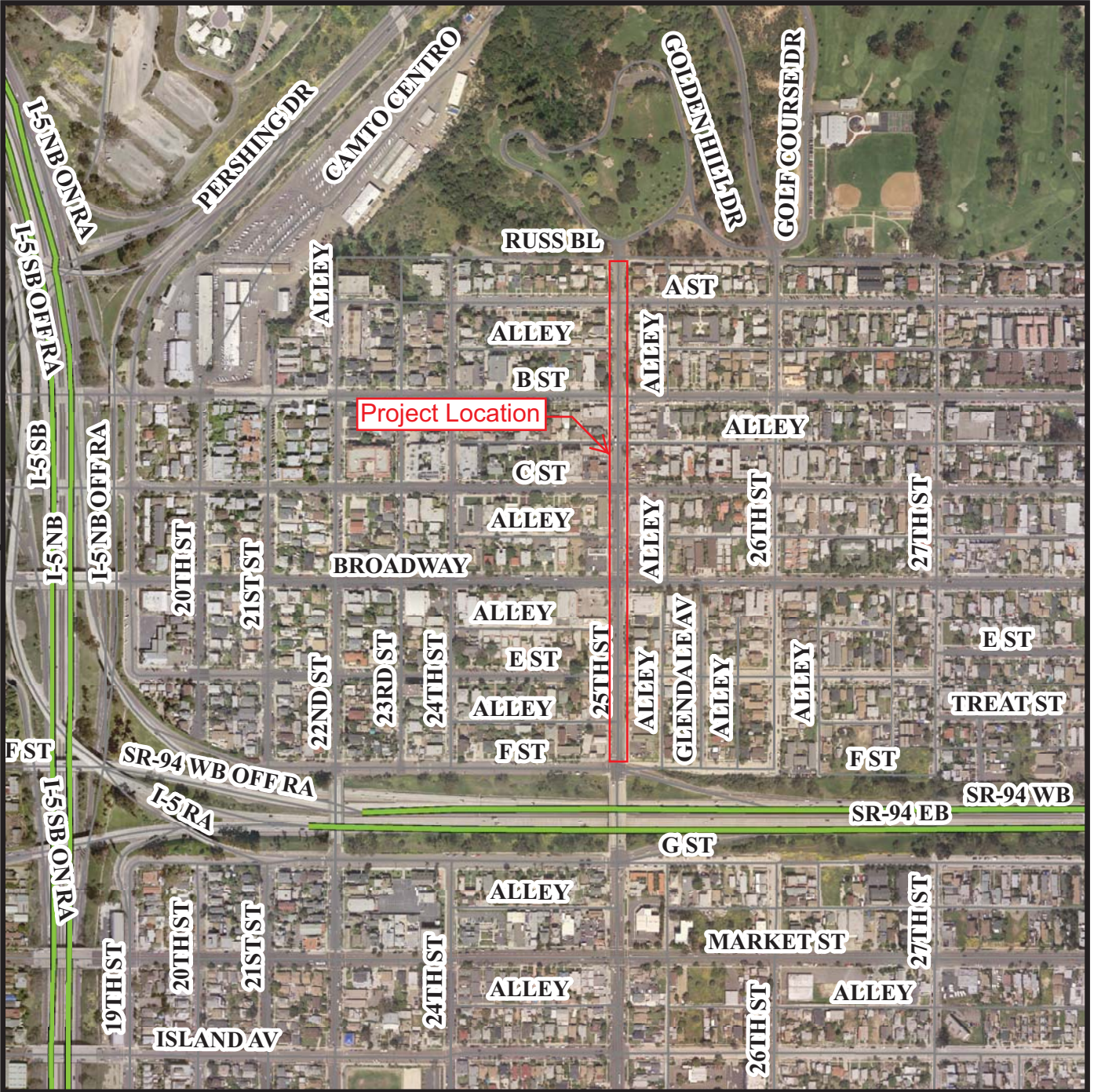

Legend



COMMUNITY NAME:
GREATER GOLDEN HILL
25th Street Renaissance Project
Date: February 11, 2013



Appendix E - Location Map
Federal No.: RPSTPLE 5004(176)

COUNCIL DISTRICT: 3



SAP ID: S00985 \\
B12016 (W)
72 | Page

THIS MAP/DATA IS PROVIDED WITHOUT WARRANTY OF ANY KIND, EITHER EXPRESS OR IMPLIED, INCLUDING, BUT NOT LIMITED TO, THE IMPLIED WARRANTIES OR MERCHANTABILITY AND FITNESS FOR A PARTICULAR PURPOSE. Note: This product may contain information reproduced with permission granted by RAND MCNALLY & COMPANY to SanGIS. This map is copyrighted by RAND MCNALLY & COMPANY. It is unlawful to copy or reproduce all or any part thereof, whether for personal use or resale, without the prior, written permission of RAND MCNALLY & COMPANY.

APPENDIX F
STORM WATER PREVENTION POLLUTION PLAN

In accordance with Whitebook Section 701-8, #6, a SWPPP outline has been prepared and available for download from:

<ftp://ftp.sannet.gov/OUT/DLi/25th%20Street%20Renaissance/>

Note that this outline is being provided for reference only. The Contractor is required to prepare his own SWPPP per Section 701 of the Whitebook.

APPENDIX G
HYDROSTATIC DISCHARGE FORM

APPENDIX

Hydrostatic Discharge Requirements Certification (Discharge Events < 500,000 gpd)

All discharge activities related to this project comply with the Regional Water Quality Control Board (RWQCB) Order No. 2002-0020, General Permit for Discharges of Hydrostatic Test Water and Potable Water to Surface Water and Storm Drains as referenced by (http://www.swrcb.ca.gov/rwqcb9/board_decisions/adopted_orders/2002/2002_0020.shtml), and as follows:

Discharged water has been dechlorinated to below 0.1 (mg/l) level; and effluent has been maintained between 6 and 9 (PH) based on:							<i>is discharge within acceptable limits?</i>		<i>Comment</i>
Event #	Discharge Date & Amount (GAL)	Discharge Time	Meter Readings (at source)	Test Results (Chlorine / PH)	Name of Personnel Conducting Tests (print)	*signature of personnel	yes	no	
	Date	Start:	Start:						
	Amt:	End:	End:						
	Date	Start:	Start:						
	Amt:	End:	End:						
	Date	Start:	Start:						
	Amt:	End:	End:						
	Date	Start:	Start:						
	Amt:	End:	End:						
	Date	Start:	Start:						
	Amt:	End:	End:						
	Date	Start:	Start:						
	Amt:	End:	End:						
	Date	Start:	Start:						
	Amt:	End:	End:						
	Date	Start:	Start:						
	Amt:	End:	End:						
	Date	Start:	Start:						
	Amt:	End:	End:						
	Date	Start:	Start:						
	Amt:	End:	End:						

*By signing, I certify that all of the statements and conditions for hydrostatic discharge events are correct.

Project Name: _____

Work Order No.(s): _____

Have any thresholds have been exceeded? Per Order No. 2002-0020, would this be a reportable discharge and must be reported **within 24 hours** of the event? [Reportable discharge would include violation of maximum gallons per day, any upset which exceeds any effluent limit]

APPENDIX H
ADJACENT PROJECT

Water Group Job 959



Legend

— GJ 959



City of San Diego

CITY CONTACT: Damian Singleton, Contract Specialist, Email: Dsingleton@sandiego.gov
Phone No. (619) 533-3482, Fax No. (619) 533-3633

ADDENDUM "A"

FOR



25TH STREET RENAISSANCE PROJECT

BID NO.:	K-14-5524-DBB-3
SAP NO. (WBS/IO/CC):	S-00985, B-12016
CLIENT DEPARTMENT:	2113, 2013
COUNCIL DISTRICT:	3
PROJECT TYPE:	IG, KB

BID DUE DATE:

**2:00 PM
OCTOBER 31, 2013
CITY OF SAN DIEGO
PUBLIC WORKS CONTRACTING GROUP
1010 SECOND AVENUE, SUITE 1400, MS 614C
SAN DIEGO, CA 92101**

ENGINEER OF WORK

The engineering Specifications and Special Provisions contained herein have been prepared by or under the direction of the following Registered Engineer:

Gerald L. Michael
1) Registered Engineer

10/25/2013
Date

Seal:



Brad Johnson
2) For City Engineer

10/25/2013
Date

Seal:

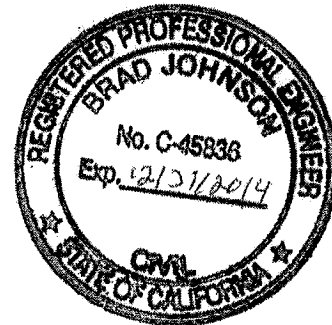

A. CHANGES TO CONTRACT DOCUMENTS

The following changes to the Contract Documents are hereby made effective as though originally issued with the bid package. Bidders are reminded that all previous requirements to this solicitation remain in full force and effect.

B. VOLUME 2

1. To Bidding Documents, Proposal (BID), Pages 11 through 16, **DELETE** in their entirety and **SUBSTITUTE** with pages 4 of 11 through 9 of 11 of this Addendum.

C. PLANS

- 1, To Drawing number 36515-02-D and 36515-03-D, **DELETE** in their entirety and **REPLACE** with pages 10 of 11 through 11 of 11 of this Addendum.

Tony Heinrichs, Director
Public Works Department

Dated: *October 25, 2013*
San Diego, California

TH/BD/NB/CA/egz

BIDDING DOCUMENTS

PROPOSAL (BID)

The Bidder agrees to the construction of **25th Street Renaissance Project**, for the City of San Diego, in accordance with these contract documents for the prices listed below. The Bidder guarantees the Contract Price for a period of 120 days (90 days for federally funded contracts and contracts valued at \$500,000 or less) from the date of Bid opening to Award of the Contract. The duration of the Contract Price guarantee shall be extended by the number of days required for the City to obtain all items necessary to fulfill all conditions precedent e.g., bond and insurance.

Item	Quantity	Unit	NAICS	Payment Reference	Description	Unit Price	Extension
BASE BID							
25TH STREET RENAISSANCE							
1.	1	LS	524126	2-4.1	Bond (Payment and Performance)	 	\$
2.	1	AL	532490	7-10.1.1.1	Reimbursement for Trailers – Type I	 	\$10,000.00
3.	1	LS	237310	7-10.2.7	Traffic Control	 	\$
4.	6	EA	238210	9-3.1	Remove and Salvage Existing Traffic Sign	\$	\$
5.	39	EA	238210	9-3.1	Relocate Existing Sign	\$	\$
6.	1	LS	238910	9-3.1	Remove and Reinstall Site Furnishings (Including Bus Shelter)	 	\$
7.	1	LS	237310	9-3.4.1	Mobilization	 	\$
8.	1	AL		9-3.5	Field Orders - Type II	 	\$80,000.00
9.	1	LS	238910	300-1.4	Clearing and Grubbing	 	\$
10.	4	EA	238910	300-1.4	Tree Removal	\$	\$
11.	1	LS	237310	301-1.7	Adjust Utilities to Grade	 	\$
12.	1,405	CY	237310	301-3.3.6	Cement Treated Base	\$	\$
13.	44,220	SF	237310	302-1.12	2” Cold Mill Asphalt Pavement	\$	\$
14.	787	TN	237310	302-5.9	4” Asphalt Concrete Pavement	\$	\$
15.	516	TN	237310	302-5.9	2” Asphalt Overlay	\$	\$
16.	1,200	SF	237310	302-6.8	Bus Stop Slab	\$	\$

BIDDING DOCUMENTS

Item	Quantity	Unit	NAICS	Payment Reference	Description	Unit Price	Extension
17.	16	LF	237110	303-1.12.2	Trench Drain and Cover Grates	\$	\$
18.	6	EA	237310	303-5.5.3.2	Decorative Emblems	\$	\$
19.	10	EA	237310	303-5.9	Relocate Contractor Date Stamps and Impressions	\$	\$
20.	2,260	LF	237310	303-5.9	Curb & Gutter, Type G	\$	\$
21.	3,750	SF	237310	303-5.9	Cross Gutter, per SDG-157	\$	\$
22.	1,255	SF	237310	303-5.9	Alley Apron, per SDG-120	\$	\$
23.	750	SF	237310	303-5.9	Driveway, per SDG-159	\$	\$
24.	525	SF	237310	303-5.9	Driveway, per SDG-160	\$	\$
25.	90	LF	237310	303-5.9	Median Curb, Type B-1, per SDG-154	\$	\$
26.	21,750	SF	237310	303-5.9	PCC Sidewalk	\$	\$
27.	850	LF	237310	303-5.9	Concrete Band, 12" Wide	\$	\$
28.	225	LF	237310	303-5.9	Concrete Band, 24" Wide	\$	\$
29.	3,675	SF	237310	303-9.2	Interlocking Concrete Pavers	\$	\$
30.	12	EA	237310	303-5.10.2	Curb Ramp Type A with Stainless Steel Detectable Warning Tiles	\$	\$
31.	8	EA	237310	303-5.10.2	Curb Ramp Type D with Stainless Steel Detectable Warning Tiles	\$	\$
32.	2	EA	237310	303-5.10.2	Curb Ramp Case A with Stainless Steel Detectable Warning Tiles	\$	\$
33.	20	LF	237110	306-1.6	Sidewalk Underdrain, per D-27	\$	\$
34.	13	EA	238210	307-2	Relocate Decorative Street Lights	\$	\$
35.	1	LS	238210	307-2	Traffic Signal Modification	\$	\$
36.	34	EA	238210	307-2	Install Traffic Sign On Post	\$	\$
37.	3,850	LF	237310	314-4.3.7	Painted Traffic Stripes	\$	\$

BIDDING DOCUMENTS

Item	Quantity	Unit	NAICS	Payment Reference	Description	Unit Price	Extension
38.	600	SF	237310	314-4.3.7	Painted Pavement Markings	\$	\$
39.	400	LF	237310	314-4.3.7	Painted Curb Markings	\$	\$
40.	10,100	LF	237310	314-4.4.6	Thermoplastic Traffic Stripes	\$	\$
41.	725	SF	237310	314-4.4.6	Thermoplastic Pavement Markings	\$	\$
42.	240	EA	237310	314-5.6	Pavement Markers (Retroreflective and Non-retroreflective)	\$	\$
43.	2	EA	237110	701-13.8.4	Storm Water Treatment Basins	\$	\$
44.	1	LS	541330	701-13.8.4	Water Pollution Control Program Development	 	\$
45.	1	LS	237990	701-13.8.4	Water Pollution Control Program Implementation	 	\$
46.	1	LS	541330	701-13.8.4	Permit Fee	 	\$
WATER GROUP JOB 960							
47.	1	LS	524126	2-4.1	Bonds (Payment and Performance)	 	\$
48.	1	EA	541214	3-3.2.2.1	Certified Payroll	\$	\$
49.	1	LS	238990	7-9.1.1	Video Recording of Pre-existing Conditions	 	\$
50.	1	LS	237110	9-3.4.1	Mobilization	 	\$
51.	1	AL		9-3.5	Field Orders - Type II	 	\$15,000.00
52.	1,000	SF	237310	302-5.2.1	Pavement Restoration Adjacent to Trench	\$	\$
53.	3	EA	237310	303-5.10.2	Curb Ramp Type A with Stainless Steel Detectable Warning Tiles	\$	\$
54.	1	LS	237110	306-1.1.6	Trench Shoring	 	\$
55.	50	CY	237110	306-1.2.1.1	Additional Bedding	\$	\$
56.	45	TON	237310	306-1.5.1	Temporary Resurfacing	\$	\$
57.	100	TON	237110	306-1.6	Imported Backfill	\$	\$
58.	41	LF	237110	306-1.6	12-Inch Water Main	\$	\$

BIDDING DOCUMENTS

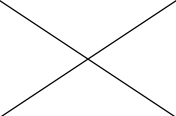
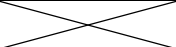
Item	Quantity	Unit	NAICS	Payment Reference	Description	Unit Price	Extension
59.	1,141	LF	237110	306-1.6	16-Inch Water Main	\$	\$
60.	9	CY	237110	306-1.6	Thrust Anchor	\$	\$
61.	1	EA	237110	306-1.6	4-Inch Fire Service Connection & Assembly	\$	\$
62.	2	EA	237110	306-1.6	6-Inch Fire Hydrant Assembly & Marker	\$	\$
63.	4	EA	237110	306-1.6	16-Inch Butterfly Valve Class 250B	\$	\$
64.	2	EA	237110	306-1.6	12-Inch Gate Valve	\$	\$
65.	15	EA	237110	306-14.1	1-Inch Water Service	\$	\$
66.	2	EA	237110	306-14.1	2-Inch Copper Water Service	\$	\$
67.	3	EA	237110	306-5.3	Remove and Cap Abandoned Water Meter Box	\$	\$
68.	2,400	LF	237110	600-1.2.1.3	High-lining Removed by Contractor	\$	\$
69.	24	EA	237110	600-1.2.1.3	Water Service Transfer from Highline	\$	\$
70.	1	LS	237110	600-1.3.1.5	Contractor Furnished Materials for City Forces Connection and Cut-in Work for Mains 16-inch and Larger		\$
71.	250	SF	237110	600-1.3.1.5	Pavement Restoration for City Forces Final Connection	\$	\$
72.	41	LF	237110	708-6	Handling and Disposal of Non-friable Asbestos Material	\$	\$
ESTIMATED TOTAL BASE BID:							\$
ALTERNATE A							
1.	-2,400	LF	237110	600-1.2.1.3	High-lining Removed by the Contractor (Base Bid Item 68)	\$	\$
2.	1	LS	237110	600-1.3.2.10	High-lining by Contractor		\$
ESTIMATED TOTAL ALTERNATE A:							\$

BIDDING DOCUMENTS

Item	Quantity	Unit	NAICS	Payment Reference	Description	Unit Price	Extension	
ALTERNATE B								
1.	-250	SF	237110	600-1.3.1.5	Pavement Restoration for City Forces Final Connection (Base Bid Item 71)	\$	\$	
2.	1	EA	237110	600-1.3.2.10	8-Inch through 16-Inch Connections to The Existing System by Contractor	\$	\$	
3.	2	EA	237110	600-1.4.9	Cut and Plug of The Existing System by Contractor	\$	\$	
ESTIMATED TOTAL ALTERNATE B:							\$	
ESTIMATED TOTAL BASE BID PLUS ALTERNATE A PLUS ALTERNATE B:							\$	

TOTAL BID PRICE FOR BID (Items 1 through 72 Plus Alternate A, item 1 through 2 Plus Alternate B, item 1 through 3, inclusive) amount written in words:

The Bid shall contain an acknowledgment of receipt of all addenda, the numbers of which shall be filled in on the Bid form. If an addendum or addenda has been issued by the City and not noted as being received by the Bidder, this proposal shall be rejected as being **non-responsive**. The following addenda have been received and are acknowledged in this bid: _____

The names of all persons interested in the foregoing proposal as principals are as follows:

IMPORTANT NOTICE: If Bidder or other interested person is a corporation, state secretary, treasurer, and manager thereof; if a co-partnership, state true name of firm, also names of all individual co-partners composing firm; if Bidder or other interested person is an individual, state first and last names in full.

BIDDING DOCUMENTS

Bidder: _____

Title: _____

Business Address: _____

Place of Business: _____

Place of Residence: _____

Signature: _____

NOTES:

- A. The City shall determine the low Bid based on the Base Bid Plus Alternates A and B.
- B. After the low Bid has been determined, the City may award the Contract for the Base Bid alone or if applicable, for the Base Bid plus any combination of alternates selected in the City's sole discretion.
- C. Prices and notations shall be in ink or typewritten. All corrections (which have been initiated by the Bidder using erasures, strike out, line out, or "white-out") shall be typed or written in with ink adjacent thereto, and shall be initialed in ink by the person signing the bid proposal.
- D. Failure to initial all corrections made in the bidding documents shall cause the Bid to be rejected as **non-responsive** and ineligible for further consideration.
- E. Blank spaces must be filled in, using figures. Bidder's failure to submit a price for any Bid item that requires the Bidder to submit a price shall render the Bid **non-responsive** and shall be cause for its rejection.
- F. Unit prices shall be entered for all unit price items. Unit prices shall not exceed two (2) decimal places. If the Unit prices entered exceed two (2) decimal places, the City will only use the first two digits after the decimal points without rounding up or down.
- G. All extensions of the unit prices bid will be subject to verification by the City. In the case of inconsistency or conflict between the product of the Quantity x Unit Price and the Extension, the product shall govern.
- H. In the case of inconsistency or conflict, between the sums of the Extensions with the estimated total Bid, the sum of the Extensions shall govern.
- I. Bids shall not contain any recapitulation of the Work. Conditional Bids will be rejected as being **non-responsive**. Alternative proposals will not be considered unless called for.

Apr. 29, 2013 - 10:27am N:\2008\1408525-25th-Renaissance\Engineering\ConDocs\Sheet-Files\100X-Submittal\1408525-DW-100.dwg

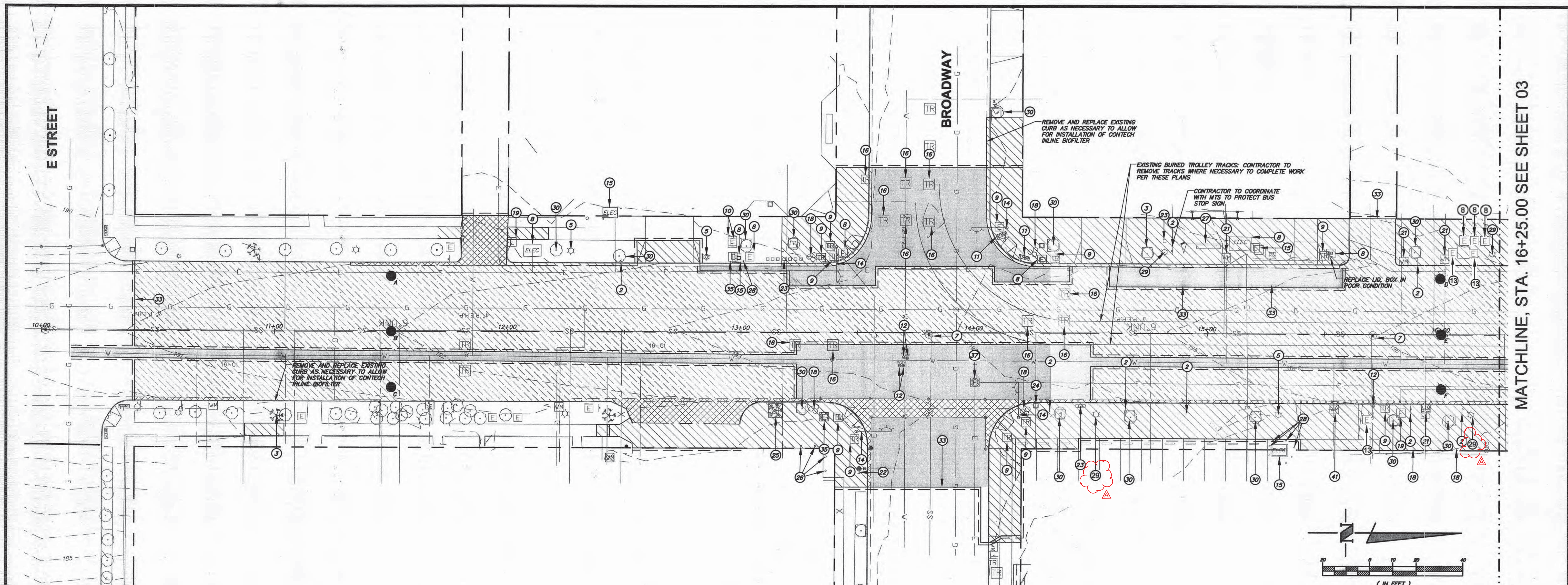

MATCHLINE, STA. 16+25.00 SEE SHEET 03

EXISTING FEATURES	
W	EXISTING WATER LINE
WL	EXISTING WATER LATERAL
WM	EXISTING WATER METER
WV	EXISTING WATER VALVE
FH	EXISTING FIRE HYDRANT
DS	EXISTING DOWN SPOUT
SS	EXISTING SEWER
SL	EXISTING SEWER LATERAL
SM	EXISTING SEWER MANHOLE
GM	EXISTING GAS METER
TS	EXISTING TRAFFIC SIGNAL
LP	EXISTING LIGHT POLE
SLT	EXISTING STREET LIGHT
TEL	EXISTING TELEPHONE MANHOLE
T	EXISTING STREET SIGN
G	EXISTING GAS LINE
C	EXISTING CONCRETE PILLAR
P	EXISTING PG&E UTILITY BOX
S	EXISTING SPLICE BOX
E	EXISTING EDISON UTILITY BOX
ELEC	EXISTING ELECTRICAL BOX
V	EXISTING VENT
SL	EXISTING STREET LIGHT
CTV	EXISTING CABLE TELEVISION BOX
TR	EXISTING UTILITY CABINET
TR	EXISTING TRAFFIC LOOP
TR	EXISTING TROLLEY TRACKS

DEMOLITION KEY	
1	EXISTING FIRE HYDRANT TO BE REPLACED. SEE SHEET 24 & 26 FOR DETAILS
2	RELOCATE SIGN PER CONSTRUCTION PLANS
3	EXISTING TREE TO BE REMOVED
4	PROTECT EXISTING BACKFLOW PREVENTOR AND ADJUST TO FINISHED GRADE. RELOCATE AS NEEDED
5	PROTECT EXISTING STREET LIGHT POLE
6	PROTECT WATER METER IN PLACE AND ADJUST TO FINISHED GRADE. IF BOX IS DAMAGED, REPLACE WITH NEW METER BOX
7	PROTECT EXISTING MANHOLE IN PLACE AND ADJUST TO FINISHED GRADE
8	PROTECT EXISTING SDGE ELECTRICAL BOX AND ADJUST TO FINISHED GRADE
9	PROTECT EXISTING TRAFFIC SIGNAL PULL BOX AND ADJUST TO FINISHED GRADE. REPLACE IF DAMAGED
10	PROTECT EXISTING STREET LIGHT BOX AND ADJUST TO FINISHED GRADE. REPLACE IF DAMAGED
11	REMOVE AND REINSTALL HISTORICAL STAMP PER CITY OF SD STD. SDG-115
12	PROTECT WATER VALVE IN PLACE AND ADJUST TO FINISHED GRADE
13	PROTECT EXISTING CABLE TELEVISION BOX AND ADJUST TO FINISHED GRADE
14	PROTECT EXISTING TRAFFIC SIGNAL POLE IN PLACE
15	PROTECT EXISTING SDGE UTILITY CABINET
16	REMOVE TRAFFIC LOOP DETECTOR WIRE. REPLACE PER TRAFFIC SIGNAL MODIFICATION PLANS
17	RELOCATE EXISTING SDGE ELECTRICAL BOX
18	PROTECT AND RELOCATE EXISTING DECORATIVE POTS TO LOCATION AS SHOWN ON STREET IMPROVEMENTS PLAN
19	RELOCATE EXISTING STREET LIGHT PULL BOX, REPLACE IF DAMAGED
20	RELOCATE EXISTING WATER VALVE
21	EXISTING WATER METER TO BE REPLACED AND RELOCATED BEHIND NEW CURB. SEE SHEETS 24 & 25 FOR DETAILS

22	PROTECT EXISTING FIRE HYDRANT IN PLACE
23	SALVAGE EXISTING NEWS RACKS FOR RELOCATION
24	RELOCATE EXISTING TRASH CANS TO LOCATION AS SHOWN ON STREET IMPROVEMENT PLANS
25	REMOVE EXISTING TREE GRATE AND RETURN TO CITY. PROTECT TREE IN PLACE
26	PROTECT UPLIGHTS IN PLACE
27	SALVAGE AND REINSTALL BUS SHELTER
28	PROTECT EXISTING BOLLARDS IN PLACE, RELOCATE IF NEEDED
29	RELOCATE EXISTING STREET LIGHT
30	PROTECT EXISTING TREE IN PLACE
31	PROTECT EXISTING ELECTRICAL BOX IN PLACE
32	REMOVE EXISTING BOLLARDS
33	SAWCUT
34	EXISTING DRIVEWAY TO REMAIN
35	PROTECT EXISTING SDGE PULLBOX AND ADJUST TO FINISHED GRADE
36	PROTECT EXISTING BENCH
37	PROTECT PAC-BELL MANHOLE LID AND ADJUST TO FINISHED GRADE
38	PROTECT EXISTING SDGE PULLBOX AND ADJUST TO FINISHED GRADE
39	PROTECT EXISTING STOP SIGN AND ADJUST TO FINISHED GRADE
40	RELOCATE EXISTING TELEPHONE BOX
41	EXISTING WATER METER TO BE REPLACED. SEE SHEETS 24 & 25 FOR DETAILS
42	EXISTING WATER METER TO BE ABANDONED. SEE SHEETS 24 & 25 FOR DETAILS

PAVEMENT CORING LEGEND	
A	8" AC / NATIVE SUBGRADE
B	10" AC / NATIVE SUBGRADE
C	8" AC / NATIVE SUBGRADE
D	4" AC / 6" PCC NATIVE SUBGRADE
E	6" AC / 10" PCC NATIVE SUBGRADE
F	6" AC / 6" PCC NATIVE SUBGRADE
G	6" AC / 6" PCC NATIVE SUBGRADE
H	5" AC / 7" PCC NATIVE SUBGRADE
I	6" AC / 6" PCC NATIVE SUBGRADE

LEGEND	
[Symbol]	REMOVE AND DISPOSE OF FULL ROAD SECTION
[Symbol]	VARIABLE DEPTH PROFILE MILL EXISTING ASPHALT CONCRETE SURFACE
[Symbol]	REMOVE AND DISPOSE OF CONCRETE SIDEWALK, BASE ROCK, CURB, AND/OR GUTTER. OVER-EXCAVATE 6" IN CONCRETE INTERLOCKING PAVING AREA
[Symbol]	REMOVE AND DISPOSE OF CONCRETE CROSS GUTTER AND/OR CONCRETE PAVEMENT
[Symbol]	APPROX. LOCATION OF PAVEMENT CORING (NOVEMBER 17, 2010)

NOTE:
TRENCHING FOR WATER SERVICE LATERALS WILL BE NECESSARY FROM NEW WATER MAIN TO METER LOCATIONS. SEE WATER GROUP JOB 960 PLANS FOR WATER METER AND LATERAL LOCATIONS.

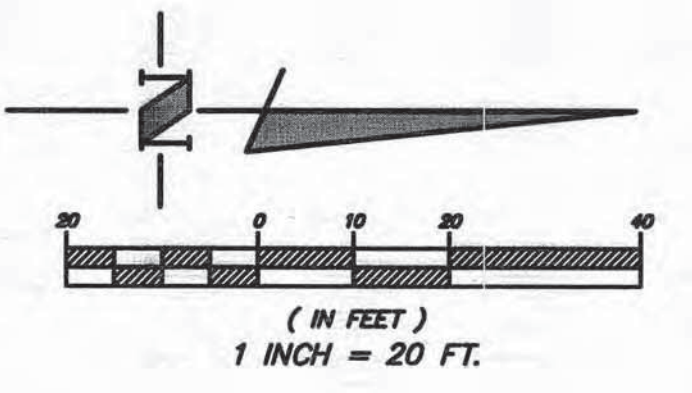

CAUTION!!
LOCATION OF EXISTING UTILITIES ON THESE PLANS ARE APPROXIMATE AND SHALL BE VERIFIED BY CONTRACTOR PRIOR TO CONSTRUCTION.

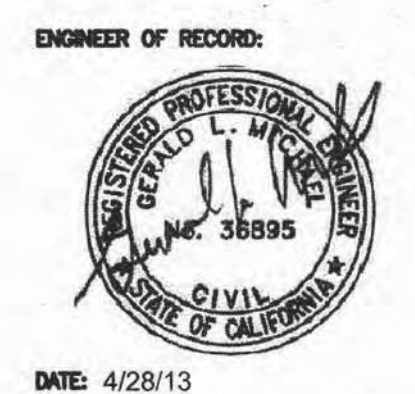

rmdesigngroup
creating environments people enjoy®
3765 South Higuera St., Ste. 102, San Luis Obispo, CA 93401
P: (805) 543-1794 | F: (805) 543-4809 | www.rmdesigngroup.com
A California Corporation | 11409 Highwayway, Ardmore (BC1000) | Jerry Michael, PE #20085, LB #0279 | Jeff Fisher, LA #204

PLANS FOR THE CONSTRUCTION OF 25TH ST. RENAISSANCE PROJECT DEMOLITION PLAN

CITY OF SAN DIEGO, CALIFORNIA PUBLIC WORKS DEPARTMENT SHEET 2 OF 29 SHEETS		DATE: 8/11/13	PROJECT ENGINEER: DAVID LI
FOR CITY ENGINEER: [Signature]	DATE: 8/11/13	ASSOCIATE ENGINEER: MARC PIRAZZINI	
DESCRIPTION	BY	APPROVED	DATE
ORIGINAL	RRM		
ADDENDUM "A"			
CONTRACTOR INSPECTOR		DATE STARTED / DATE COMPLETED	
		36515-02-D	

MATCHLINE, STA. 16+25.00 SEE SHEET 02

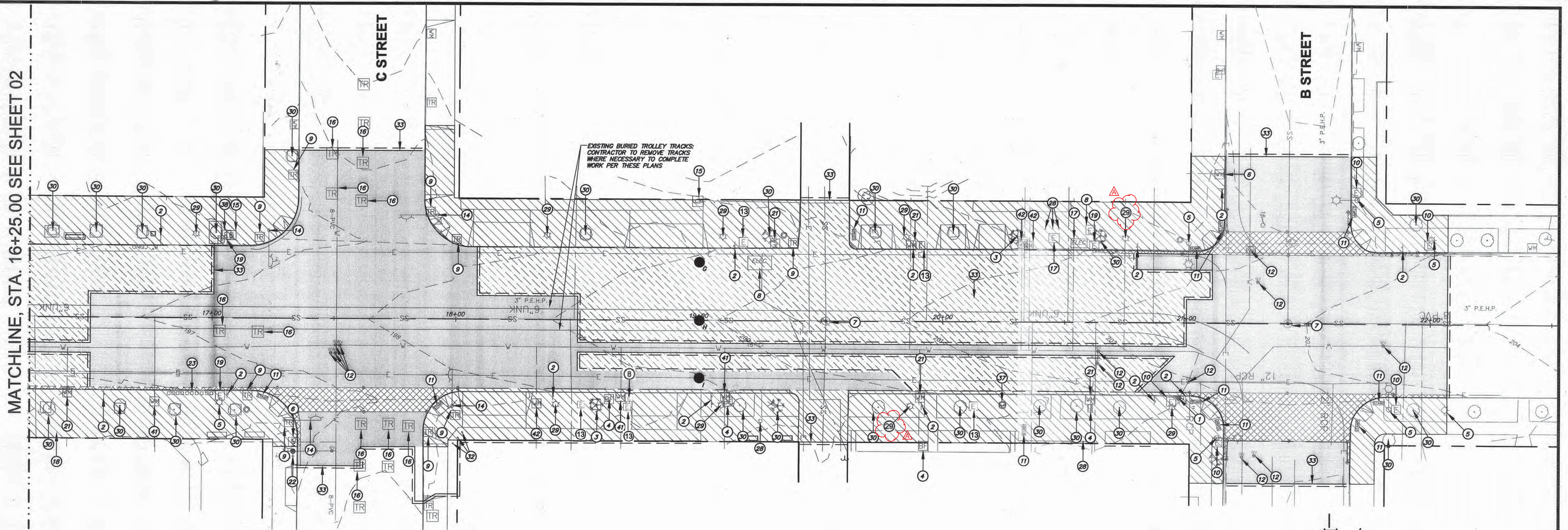

EXISTING BURIED TROLLEY TRACKS
CONTRACTOR TO REMOVE TRACKS
WHERE NECESSARY TO COMPLETE
WORK PER THESE PLANS

EXISTING FEATURES

—	EXISTING WATER LINE
—	EXISTING WATER LATERAL
WM	EXISTING WATER METER
WV	EXISTING WATER VALVE
—	EXISTING FIRE HYDRANT
DS	EXISTING DOWN SPOUT
SS	EXISTING SEWER
—	EXISTING SEWER LATERAL
SM	EXISTING SEWER MANHOLE
GM	EXISTING GAS METER
—	EXISTING TRAFFIC SIGNAL
—	EXISTING LIGHT POLE
—	EXISTING STREET LIGHT
TEL	EXISTING TELEPHONE MANHOLE
—	EXISTING STREET SIGN
G	EXISTING GAS LINE
E	EXISTING CONCRETE PILLAR
—	EXISTING PG&E UTILITY BOX
—	EXISTING SPLICE BOX
—	EXISTING EDISON UTILITY BOX
—	EXISTING TREE
ELEC	EXISTING ELECTRICAL BOX
—	EXISTING VENT
SL	EXISTING STREET LIGHT
CTV	EXISTING CABLE TELEVISION BOX
TR	EXISTING UTILITY CABINET
TR	EXISTING TRAFFIC LOOP
TR	EXISTING TROLLEY TRACKS

DEMOLITION KEY

1	EXISTING FIRE HYDRANT TO BE REPLACED. SEE SHEET 24 & 26 FOR DETAILS
2	RELOCATE SIGN PER CONSTRUCTION PLANS
3	EXISTING TREE TO BE REMOVED
4	PROTECT EXISTING BACKFLOW PREVENTOR AND ADJUST TO FINISHED GRADE. RELOCATE AS NEEDED
5	PROTECT EXISTING STREET LIGHT POLE
6	PROTECT WATER METER IN PLACE AND ADJUST TO FINISHED GRADE. IF BOX IS DAMAGED, REPLACE WITH NEW METER BOX.
7	PROTECT EXISTING MANHOLE IN PLACE AND ADJUST TO FINISHED GRADE
8	PROTECT EXISTING SDGE ELECTRICAL BOX AND ADJUST TO FINISHED GRADE
9	PROTECT EXISTING TRAFFIC SIGNAL PULL BOX AND ADJUST TO FINISHED GRADE. REPLACE IF DAMAGED
10	PROTECT EXISTING STREET LIGHT BOX AND ADJUST TO FINISHED GRADE. REPLACE IF DAMAGED
11	REMOVE AND REINSTALL HISTORICAL STAMP PER CITY OF SD STD. SDG-115
12	PROTECT WATER VALVE IN PLACE AND ADJUST TO FINISHED GRADE
13	PROTECT EXISTING CABLE TELEVISION BOX AND ADJUST TO FINISHED GRADE
14	PROTECT EXISTING TRAFFIC SIGNAL POLE IN PLACE
15	PROTECT EXISTING SDGE UTILITY CABINET
16	REMOVE TRAFFIC LOOP DETECTOR WIRE. REPLACE PER TRAFFIC SIGNAL MODIFICATION PLANS
17	RELOCATE EXISTING SDGE ELECTRICAL BOX
18	PROTECT AND RELOCATE EXISTING DECORATIVE POTS TO LOCATION AS SHOWN ON STREET IMPROVEMENTS PLAN
19	RELOCATE EXISTING STREET LIGHT PULL BOX, REPLACE IF DAMAGED
20	RELOCATE EXISTING WATER VALVE
21	EXISTING WATER METER TO BE REPLACED AND RELOCATED BEHIND NEW CURB. SEE SHEETS 24 & 25 FOR DETAILS

22	PROTECT EXISTING FIRE HYDRANT IN PLACE
23	SALVAGE EXISTING NEWS RACKS FOR RELOCATION
24	RELOCATE EXISTING TRASH CANS TO LOCATION AS SHOWN ON STREET IMPROVEMENT PLANS
25	REMOVE EXISTING TREE GRATE AND RETURN TO CITY. PROTECT TREE IN PLACE
26	PROTECT UPLIGHTS IN PLACE
27	SALVAGE AND REINSTALL BUS SHELTER
28	PROTECT EXISTING BOLLARDS IN PLACE, RELOCATE IF NEEDED
29	RELOCATE EXISTING STREET LIGHT
30	PROTECT EXISTING TREE IN PLACE
31	PROTECT EXISTING ELECTRICAL BOX IN PLACE
32	REMOVE EXISTING BOLLARDS
33	SAWCUT
34	EXISTING DRIVEWAY TO REMAIN
35	PROTECT EXISTING SDGE PULLBOX AND ADJUST TO FINISHED GRADE
36	PROTECT EXISTING BENCH
37	PROTECT PAC-BELL MANHOLE LID AND ADJUST TO FINISHED GRADE
38	PROTECT EXISTING SDGE PULLBOX AND ADJUST TO FINISHED GRADE
39	PROTECT EXISTING STOP SIGN AND ADJUST TO FINISHED GRADE
40	RELOCATE EXISTING TELEPHONE BOX
41	EXISTING WATER METER TO BE REPLACED. SEE SHEETS 24 & 25 FOR DETAILS
42	EXISTING WATER METER TO BE ABANDONED. SEE SHEETS 24 & 25 FOR DETAILS

PAVEMENT CORING LEGEND

A	6" AC / NATIVE SUBGRADE
B	10" AC / NATIVE SUBGRADE
C	8" AC / NATIVE SUBGRADE
D	4" AC / 6" PCC NATIVE SUBGRADE
E	6" AC / 10" PCC NATIVE SUBGRADE
F	5" AC / 6" PCC NATIVE SUBGRADE
G	6" AC / 6" PCC NATIVE SUBGRADE
H	5" AC / 7" PCC NATIVE SUBGRADE
I	6" AC / 6" PCC NATIVE SUBGRADE

LEGEND

□	REMOVE AND DISPOSE OF FULL ROAD SECTION
▨	VARIABLE DEPTH PROFILE MILL EXISTING ASPHALT CONCRETE SURFACE
▩	REMOVE AND DISPOSE OF CONCRETE SIDEWALK, BASE ROCK, CURB, AND/OR GUTTER. OVER-EXCAVATE 6" IN CONCRETE INTERLOCKING PAVING AREA
▧	REMOVE AND DISPOSE OF CONCRETE CROSS GUTTER AND/OR CONCRETE PAVEMENT
●	APPROX. LOCATION OF PAVEMENT CORING (NOVEMBER 17, 2010)

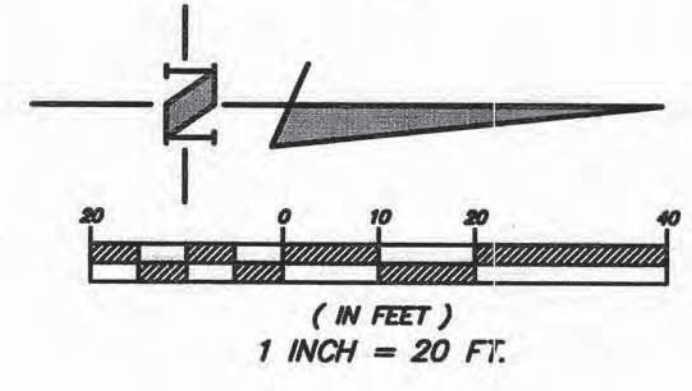

NOTE:
TRENCHING FOR WATER SERVICE LATERALS WILL BE NECESSARY FROM NEW WATER MAIN TO METER LOCATIONS. SEE WATER GROUP JOB 960 PLANS FOR WATER METER AND LATERAL LOCATIONS

D-2

**PLANS FOR THE CONSTRUCTION OF
25TH ST. RENAISSANCE PROJECT
DEMOLITION PLAN**

CITY OF SAN DIEGO, CALIFORNIA PUBLIC WORKS DEPARTMENT SHEET 3 OF 29 SHEETS		WBS - S-00985
APPROVED BY: <i>David Li</i>	DATE: 8/11/13	SUBMITTED BY: DAVID LI ASSOCIATE ENGINEER
DESCRIPTION: ORIGINAL	BY: RRM	PROJECT ENGINEER: MARC PIRAZZINI
ADDENDUM "A"		200-1795
		CCS27 COORDINATE: 6286407-1838444
		CCS83 COORDINATE: 36515-03-D
CONTRACTOR INSPECTOR	DATE STARTED	DATE COMPLETED

CAUTION!!
LOCATION OF EXISTING UTILITIES ON THESE PLANS ARE APPROXIMATE AND SHALL BE VERIFIED BY CONTRACTOR PRIOR TO CONSTRUCTION.



rrmdesigngroup
creating environments people enjoy®

3765 South Highways St., Ste. 102, San Luis Obispo, CA 93401
P: (805) 543-1794 F: (805) 543-4929 www.rrmdesign.com

DATE: 4/28/13

Apr 29, 2013 10:25am N:\2008\1408825-25th-Renaissance\Engineering\Comp\Draw\Sheet\1408825-DW-100.dwg

City of San Diego

CITY CONTACT: Damian Singleton, Contract Specialist, Email: Dsingleton@sandiego.gov
Phone No. (619) 533-3482, Fax No. (619) 533-3633

ADDENDUM "B"

FOR



25TH STREET RENAISSANCE PROJECT

BID NO.:	K-14-5524-DBB-3
SAP NO. (WBS/IO/CC):	S-00985, B-12016
CLIENT DEPARTMENT:	2113, 2013
COUNCIL DISTRICT:	3
PROJECT TYPE:	IG, KB

BID DUE DATE:

**2:00 PM
OCTOBER 31, 2013
CITY OF SAN DIEGO
PUBLIC WORKS CONTRACTING GROUP
1010 SECOND AVENUE, SUITE 1400, MS 614C
SAN DIEGO, CA 92101**

ENGINEER OF WORK

The engineering Specifications and Special Provisions contained herein have been prepared by or under the direction of the following Registered Engineer:



1) For City Engineer

10/30/13
Date

Seal:



10/30/13

A. CHANGES TO CONTRACT DOCUMENTS

The following changes to the Contract Documents are hereby made effective as though originally issued with the bid package. Bidders are reminded that all previous requirements to this solicitation remain in full force and effect.

B. BIDDER'S QUESTIONS

Q1. Plan sheets C-11 & C-12 (sheets 24 & 25 of 29) show the new 16" PVC water line at the same elevations as the existing 16" Cast Iron water line. The plan notes call for only cap and plug of the existing line, not removal. Without removing the existing main, we don't see how it is possible to install the new water line in the same alignment and elevation as the existing.

Even if the new alignment is supposed to be parallel with the existing, there are still conflicts with all of the main cross-street connections and at least some of the lateral connections.

Shouldn't the existing 16" cast iron water line be removed in order to accommodate the new water line? What are we missing that makes leaving it in place workable? Please clarify.

A1. The Plans show the existing 16" cast iron water main to be removed and replaced with a 16" PVC water main. Please refer section 306-5.3.

Q2. The legend on plan sheet G-2 (Sheet 23 of 29) says to cut & plug the existing 16" main and references Standard Drawing WP-03. It is our understanding that under the base bid, this work will be done by city forces. Under Alternate B, it will be done by the Contractor.

Note 4 on Standard Drawing WP-03 says: "Existing mains 400mm (16") and larger require the entire length of the pipe to be filled by pressure grouting or by blown sand."

Does bid Item 3 of Alternate 'B' include only cutting and plugging, or the complete backfilling of the existing 16" main? Please clarify.

A2. Item 3 of Alternate 'B' includes cutting and plugging and complete backfilling of the existing 16" water main.

Q3. Per page 44 of Volume 1 of the 25th St Renaissance Project, the decorative emblems are supposedly fabricated by "The Sign Place." However, I called them for a quote and I was told that they were not the outfit chosen by the design engineer (RRMdesigngroup) to fabricate the emblems. Can you please provide me with the company that has the approval by the City to make/quote the specified emblems in bid item 18?

A3. Please see changes to the Supplementary Special Provisions as part of this Addendum.

C. VOLUME 1

1. To the Supplementary Special Provisions, page 44, subsection 303-5.5.3.1, 3rd paragraph, **DELETE** in its entirety and **SUBSTITUTE** with the following:

Fabrication of emblem is available through “The Sign Place”, Tel: 805-781-2091 or approved equal.

Tony Heinrichs, Director
Public Works Department

Dated: *October 30, 2013*
San Diego, California

TH/BD/egz

City of San Diego

CITY CONTACT: Damian Singleton, Contract Specialist, Email: Dsingleton@sandiego.gov
Phone No. (619) 533-3482, Fax No. (619) 533-3633

ADDENDUM "C"

FOR



25th STREET RENAISSANCE PROJECT

BID NO.:	K-14-5524-DBB-3
SAP NO. (WBS/IO/CC):	S-00985, B-12016
CLIENT DEPARTMENT:	2113, 2013
COUNCIL DISTRICT:	3
PROJECT TYPE:	IG, KB

BID DUE DATE:

2:00 PM
NOVEMBER 12, 2013
CITY OF SAN DIEGO
PUBLIC WORKS CONTRACTING GROUP
1010 SECOND AVENUE, SUITE 1400, MS 614C
SAN DIEGO, CA 92101

A. CHANGES TO CONTRACT DOCUMENTS

The following changes to the Contract Documents are hereby made effective as though originally issued with the bid package. Bidders are reminded that all previous requirements to this solicitation remain in full force and effect.

THE SUBMITTAL DATE FOR THIS PROJECT HAS BEEN EXTENDED AS STATED ON THE COVER PAGE.

Tony Heinrichs, Director
Public Works Department

Dated: *October 31, 2013*
San Diego, California

TH/BD/ez

City of San Diego

CITY CONTACT: Damian Singleton - Contract Specialist, Email: dsingleton@sandiego.gov
Phone No. (619) 533-3482 - Fax No. (619) 533-3633

ADDENDUM "D"

FOR



25TH STREET RENAISSANCE PROJECT

BID NO.: K-14-5524-DBB-3
SAP NO. (WBS/IO/CC): S-00985, B-12016
CLIENT DEPARTMENT: 2113, 2013
COUNCIL DISTRICT: 3
PROJECT TYPE: IG, KB
FEDERAL AID PROJECT NO.: RPSTPLE 5004(176)

BID DUE DATE:

**2:00 PM
NOVEMBER 12, 2013
CITY OF SAN DIEGO
PUBLIC WORKS CONTRACTING GROUP
1010 SECOND AVENUE, SUITE 1400, MS 614C
SAN DIEGO, CA 92101**

ENGINEER OF WORK

The engineering Specifications and Special Provisions contained herein have been prepared by or under the direction of the following Registered Engineer:

1) For City Engineer

11/1/13
Date

Seal:

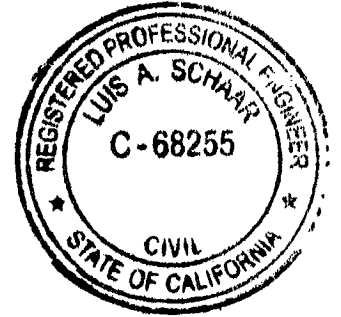

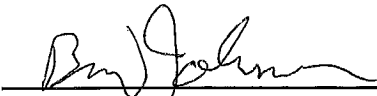
2) For City Engineer

11/1/13
Date

Seal:



A. CHANGES TO CONTRACT DOCUMENTS

The following changes to the Contract Documents are hereby made effective as though originally issued with the bid package. Bidders are reminded that all previous requirements to this solicitation remain in full force and effect.

B. BIDDER'S QUESTIONS

Q1. Addendum B for 25th St Renaissance addresses our question regarding the Emblem Vendor. However, all the city did is delete the Vendor in the original specs and replace it with the exact same info and vendor.

Can you let us know who RRM Design contacted for these custom emblems?

A1. Addendum B added "or approved equal" to the original emblem vendor. Therefore, contractors are free to use any vendor to manufacture the emblem as long as shop drawings are submitted for review per the specifications.

C. ADDENDUM A

1. Item B, Volume 2, sub-item 1, Bidding Documents, Proposal (BID), pages 4 through 9, **DELETE** in their entirety and **SUBSTITUTE** with page 4 of 11 through 11 of 11 of this Addendum.

Tony Heinrichs, Director
Public Works Department

Dated: *November 1, 2013*
San Diego, California

TH/BD/egz

BIDDING DOCUMENTS

PROPOSAL (BID)

The Bidder agrees to the construction of **25th Street Renaissance Project**, for the City of San Diego, in accordance with these contract documents for the prices listed below. The Bidder guarantees the Contract Price for a period of 120 days (90 days for federally funded contracts and contracts valued at \$500,000 or less) from the date of Bid opening to Award of the Contract. The duration of the Contract Price guarantee shall be extended by the number of days required for the City to obtain all items necessary to fulfill all conditions precedent e.g., bond and insurance.

Item	Quantity	Unit	NAICS	Payment Reference	Description	Unit Price	Extension
BASE BID							
25TH STREET RENAISSANCE							
1.	1	LS	524126	2-4.1	Bond (Payment and Performance)	 	\$
2.	1	AL	532490	7-10.1.1.1	Reimbursement for Trailers - Type I	 	\$10,000.00
3.	1	LS	237310	7-10.2.7	Traffic Control	 	\$
4.	6	EA	238210	9-3.1	Remove and Salvage Existing Traffic Sign	\$	\$
5.	39	EA	238210	9-3.1	Relocate Existing Sign	\$	\$
6.	1	LS	238910	9-3.1	Remove and Reinstall Site Furnishings (Including Bus Shelter)	 	\$
7.	1	LS	237310	9-3.4.1	Mobilization	 	\$
8.	1	AL		9-3.5	Field Orders - Type II	 	\$80,000.00
9.	1	LS	238910	300-1.4	Clearing and Grubbing	 	\$
10.	4	EA	238910	300-1.4	Tree Removal	\$	\$
11.	1	LS	237310	301-1.7	Adjust Utilities to Grade	 	\$

BIDDING DOCUMENTS

Item	Quantity	Unit	NAICS	Payment Reference	Description	Unit Price	Extension
12.	1,405	CY	237310	301-3.3.6	Cement Treated Base	\$	\$
13.	44,220	SF	237310	302-1.12	2" Cold Mill Asphalt Pavement	\$	\$
14.	787	TN	237310	302-5.9	4" Asphalt Concrete Pavement	\$	\$
15.	516	TN	237310	302-5.9	2" Asphalt Overlay	\$	\$
16.	1,200	SF	237310	302-6.8	Bus Stop Slab	\$	\$
17.	16	LF	237110	303-1.12.2	Trench Drain and Cover Grates	\$	\$
18.	6	EA	237310	303-5.5.3.2	Decorative Emblems	\$	\$
19.	10	EA	237310	303-5.9	Relocate Contractor Date Stamps and Impressions	\$	\$
20.	2,260	LF	237310	303-5.9	Curb & Gutter, Type G	\$	\$
21.	3,750	SF	237310	303-5.9	Cross Gutter, per SDG-157	\$	\$
22.	1,255	SF	237310	303-5.9	Alley Apron, per SDG-120	\$	\$
23.	750	SF	237310	303-5.9	Driveway, per SDG-159	\$	\$
24.	525	SF	237310	303-5.9	Driveway, per SDG-160	\$	\$
25.	90	LF	237310	303-5.9	Median Curb, Type B-1, per SDG-154	\$	\$
26.	21,750	SF	237310	303-5.9	PCC Sidewalk	\$	\$
27.	850	LF	237310	303-5.9	Concrete Band, 12" Wide	\$	\$
28.	225	LF	237310	303-5.9	Concrete Band, 24" Wide	\$	\$
29.	3,675	SF	237310	303-9.2	Interlocking Concrete Pavers	\$	\$

BIDDING DOCUMENTS

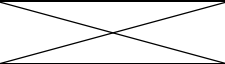
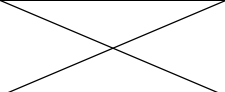
Item	Quantity	Unit	NAICS	Payment Reference	Description	Unit Price	Extension
30.	12	EA	237310	303-5.10.2	Curb Ramp Type A with Stainless Steel Detectable Warning Tiles	\$	\$
31.	8	EA	237310	303-5.10.2	Curb Ramp Type D with Stainless Steel Detectable Warning Tiles	\$	\$
32.	2	EA	237310	303-5.10.2	Curb Ramp Case A with Stainless Steel Detectable Warning Tiles	\$	\$
33.	20	LF	237110	306-1.6	Sidewalk Underdrain, per D-27	\$	\$
34.	13	EA	238210	307-2	Relocate Decorative Street Lights	\$	\$
35.	1	LS	238210	307-2	Traffic Signal Modification		\$
36.	34	EA	238210	307-2	Install Traffic Sign On Post	\$	\$
37.	3,850	LF	237310	314-4.3.7	Painted Traffic Stripes	\$	\$
38.	600	SF	237310	314-4.3.7	Painted Pavement Markings	\$	\$
39.	400	LF	237310	314-4.3.7	Painted Curb Markings	\$	\$
40.	10,100	LF	237310	314-4.4.6	Thermoplastic Traffic Stripes	\$	\$
41.	725	SF	237310	314-4.4.6	Thermoplastic Pavement Markings	\$	\$
42.	240	EA	237310	314-5.6	Pavement Markers (Retroreflective and Non-retroreflective)	\$	\$
43.	2	EA	237110	701-13.8.4	Storm Water Treatment Basins	\$	\$
44.	1	LS	541330	701-13.8.4	Water Pollution Control Program Development		\$

BIDDING DOCUMENTS

Item	Quantity	Unit	NAICS	Payment Reference	Description	Unit Price	Extension
45.	1	LS	237990	701-13.8.4	Water Pollution Control Program Implementation		\$
46.	1	AL	541330	701-13.8.4	Permit Fee - Type I		\$664.00
WATER GROUP JOB 960							
47.	1	LS	524126	2-4.1	Bonds (Payment and Performance)		\$
48.	1	EA	541214	3-3.2.2.1	Certified Payroll	\$	\$
49.	1	LS	238990	7-9.1.1	Video Recording of Pre-existing Conditions		\$
50.	1	LS	237110	9-3.4.1	Mobilization		\$
51.	1	AL		9-3.5	Field Orders - Type II		\$15,000.00
52.	1,000	SF	237310	302-5.2.1	Pavement Restoration Adjacent to Trench	\$	\$
53.	3	EA	237310	303-5.10.2	Curb Ramp Type A with Stainless Steel Detectable Warning Tiles	\$	\$
54.	1	LS	237110	306-1.1.6	Trench Shoring		\$
55.	50	CY	237110	306-1.2.1.1	Additional Bedding	\$	\$
56.	45	TON	237310	306-1.5.1	Temporary Resurfacing	\$	\$
57.	100	TON	237110	306-1.6	Imported Backfill	\$	\$
58.	41	LF	237110	306-1.6	12-Inch Water Main	\$	\$
59.	1,141	LF	237110	306-1.6	16-Inch Water Main	\$	\$
60.	9	CY	237110	306-1.6	Thrust Anchor	\$	\$

BIDDING DOCUMENTS

Item	Quantity	Unit	NAICS	Payment Reference	Description	Unit Price	Extension	
61.	1	EA	237110	306-1.6	4-Inch Fire Service Connection & Assembly	\$	\$	
62.	2	EA	237110	306-1.6	6-Inch Fire Hydrant Assembly & Marker	\$	\$	
63.	4	EA	237110	306-1.6	16-Inch Butterfly Valve Class 250B	\$	\$	
64.	2	EA	237110	306-1.6	12-Inch Gate Valve	\$	\$	
65.	40	LF	237110	306-5.3	Large Water Main Abandonment	\$	\$	
66.	15	EA	237110	306-14.1	1-Inch Water Service	\$	\$	
67.	2	EA	237110	306-14.1	2-Inch Copper Water Service	\$	\$	
68.	3	EA	237110	306-5.3	Remove and Cap Abandoned Water Meter Box	\$	\$	
69.	2,400	LF	237110	600-1.2.1.3	High-lining Removed by Contractor	\$	\$	
70.	24	EA	237110	600-1.2.1.3	Water Service Transfer from Highline	\$	\$	
71.	1	LS	237110	600-1.3.1.5	Contractor Furnished Materials for City Forces Connection and Cut-in Work for Mains 16-Inch and Larger	X	\$	
72.	250	SF	237110	600-1.3.1.5	Pavement Restoration for City Forces Final Connection		\$	\$
73.	41	LF	237110	708-6	Handling and Disposal of Non-friable Asbestos Material	\$	\$	
ESTIMATED TOTAL BASE BID:							\$	\$

BIDDING DOCUMENTS

Item	Quantity	Unit	NAICS	Payment Reference	Description	Unit Price	Extension
ALTERNATE A							
1.	-2,400	LF	237110	600-1.2.1.3	High-lining Removed by Contractor (Base Bid Item 69)	\$	\$
2.	1	LS	237110	600-1.3.2.10	High-lining by Contractor	 	\$
ESTIMATED TOTAL ALTERNATE A:							\$
ALTERNATE B							
1.	-250	SF	237110	600-1.3.1.5	Pavement Restoration for City Forces Final Connection (Base Bid Item 72)	\$	\$
2.	1	EA	237110	600-1.3.2.10	8-Inch through 16-Inch Connections to the Existing System by Contractor	\$	\$
3.	2	EA	237110	600-1.4.9	Cut and Plug of the Existing System by Contractor	\$	\$
ESTIMATED TOTAL ADDITIVE ALTERNATE B:							\$
ESTIMATED TOTAL BID PLUS ALTERNATE A PLUS ALTERNATE B:							\$

TOTAL BID PRICE FOR BID (Items 1 through 73 Plus Alternate A, item 1 through 2 Plus Alternate B, item 1 through 3, inclusive) amount written in words:

The Bid shall contain an acknowledgment of receipt of all addenda, the numbers of which shall be filled in on the Bid form. If an addendum or addenda has been issued by the City and not noted as being received by the Bidder, this proposal shall be rejected as being **non-responsive**. The following addenda have been received and are acknowledged in this bid: _____

BIDDING DOCUMENTS

The names of all persons interested in the foregoing proposal as principals are as follows:

IMPORTANT NOTICE: If Bidder or other interested person is a corporation, state secretary, treasurer, and manager thereof; if a co-partnership, state true name of firm, also names of all individual co-partners composing firm; if Bidder or other interested person is an individual, state first and last names in full.

Bidder: _____

Title: _____

Business Address: _____

Place of Business: _____

Place of Residence: _____

Signature: _____

BIDDING DOCUMENTS

NOTES:

- A. The City shall determine the low Bid based on the Base Bid plus Alternates A and B.
- B. After the low Bid has been determined, the City may award the Contract for the Base Bid alone or if applicable, for the Base Bid plus any combination of alternates selected in the City's sole discretion.
- C. Prices and notations shall be in ink or typewritten. All corrections (which have been initiated by the Bidder using erasures, strike out, line out, or "white-out") shall be typed or written in with ink adjacent thereto, and shall be initialed in ink by the person signing the bid proposal.
- D. Failure to initial all corrections made in the bidding documents shall cause the Bid to be rejected as **non-responsive** and ineligible for further consideration.
- E. Blank spaces must be filled in, using figures. Bidder's failure to submit a price for any Bid item that requires the Bidder to submit a price shall render the Bid **non-responsive** and shall be cause for its rejection.
- F. Unit prices shall be entered for all unit price items. Unit prices shall not exceed two (2) decimal places. If the Unit prices entered exceed two (2) decimal places, the City will only use the first two digits after the decimal points without rounding up or down.
- G. All extensions of the unit prices bid will be subject to verification by the City. In the case of inconsistency or conflict between the product of the Quantity x Unit Price and the Extension, the product shall govern.
- H. In the case of inconsistency or conflict, between the sums of the Extensions with the estimated total Bid, the sum of the Extensions shall govern.
- I. Bids shall not contain anSy recapitulation of the Work. Conditional Bids will be rejected as being **non-responsive**. Alternative proposals will not be considered unless called for.

City of San Diego

CITY CONTACT: Damian Singleton, Contract Specialist, Email: Dsingleton@sandiego.gov
Phone No. (619) 533-3482, Fax No. (619) 533-3633

ADDENDUM "E"

FOR

25TH STREET RENAISSANCE PROJECT



BID NO.: _____ K-14-5524-DBB-3
SAP NO. (WBS/IO/CC): _____ S-00985, B-12016
CLIENT DEPARTMENT: _____ 2113, 2013
COUNCIL DISTRICT: _____ 3
PROJECT TYPE: _____ IG, KB
FEDERAL AID PROJECT NO.: _____ RPSTPLE 5004(176)

BID DUE DATE:

**2:00 PM
DECEMBER 3, 2013
CITY OF SAN DIEGO
PUBLIC WORKS CONTRACTING GROUP
1010 SECOND AVENUE, SUITE 1400, MS 614C
SAN DIEGO, CA 92101**

ENGINEER OF WORK

The engineering Specifications and Special Provisions contained herein have been prepared by or under the direction of the following Registered Engineer:

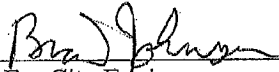

For City Engineer

11/8/13
Date

Seal:



A. CHANGES TO CONTRACT DOCUMENTS

The following changes to the Contract Documents are hereby made effective as though originally issued with the bid package. Bidders are reminded that all previous requirements to this solicitation remain in full force and effect.

THE SUBMITTAL DATE FOR THIS PROJECT HAS BEEN EXTENDED AS STATED ON THE COVER PAGE.

B. BIDDER'S QUESTIONS

Q1. Paragraph 2 of Section 302-1.6 of the Supplementary Special Provisions says in part: "...Any where it is necessary to cold mill to a depth that exceeds the thickness of the existing asphalt paving and extends down to the Portland cement concrete paving, shall be completely demolished and disposed of, per the requirements of "Clearing and Grubbing."

It is also very likely that Portland cement concrete paving will be encountered in the water main trench line, and will need to be removed.

How thick is the existing Portland cement concrete paving? And, is it reinforced with rebar, welded wire mesh or some other form of reinforcement?

The responsibility for determining the concrete pavement thickness and reinforcement, if any, should rightfully be the City's, not the contractor's, who would have no way of making such a determination. The contractor should not have to guess and gamble on something as variable as these two questions.

A1. Trench caps are constructed per Standard Drawing SDG-107, which calls for up to 9" of PCC without any reinforcement.

Q2. Section 302-3.2, paragraph 1, says: "Payment for replacement of existing pavement when required shall be included in the unit bid price for Asphalt Pavement repair for the total area replaced and no additional payment shall be made regardless of the number of replacements completed..."

Section 302-3.2, paragraph 2, says: "The areas and quantities shown on the road segments and in appendices are given only for the Contractor's aid in planning the Work and preparing Bids..."

There is no bid item in the bid schedule for "Asphalt Pavement Repair."

There are no areas and quantities for this work shown on the plans.

There is no Appendix giving areas and quantities for this work.

A2. Section 302-3, "Preparatory Repair Work" in the SSP is a correction to the 2012 City Supplement. The standard specification may or may not apply depending on the project's scope of work. It does not apply to this project.

- Q3. Detail F on plan sheet C-7, calls for "Engraved Donor Brick Pavers" and says to see plan for location. We cannot find any locations on the improvement plans for these items. Neither do we find any thing on the plans or in the specifications telling us how we are to be paid for this work.

Indicate on revised plans how many and where these items are to be installed, and provide a new and separate bid item for "Engraved donor Brick Pavers" with a quantity for the number to be provided, not just a Lump Sum.

What is the definition of O.F.C.I.?

- A3. The note about Engraved Donor Brick Pavers was inadvertently left in Detail F of the plans. It does not apply to this project. See Clarification #1 below.
- Q4. The addition of the phrase "or approved equal" with regard to the decorative emblems is not adequate to obtain a subquote for the item. Bidders have no way to qualify a manufacturer as approved by the City.

Provide the bidders with a list of manufacturers whom the City has determined to be an acceptable and "approved equal."

- A4. Addendum D clarified that you are free to use any vendor as long as shop drawings are submitted for approval.
- Q5. Paragraph 2 of Section 302-1.6, Cold Milling of Composite Pavements of the Supplementary Special Provisions says "The thickness of all existing pavement material was not know at the time of the project design. Any areas where it is necessary to cold mill to a depth that exceeds the thickness of the existing asphalt paving and extends down to the Portland cement concrete paving, shall be completely demolished and disposed of, per the requirements of "Clearing and Grubbing."

Without a more complete and detailed plan indicating the variable thicknesses of the existing asphalt pavement, the scope of this work is non-quantifiable and puts the bidder into a high risk position of guessing, which is an unfair situation.

Provide a more complete and detailed plan indicating the variable thicknesses of the existing asphalt pavement removal.

The responsibility for determining the existing asphalt pavement thickness should rightfully be the City's, not the contractor's, who would have no way of making such a determination. The contractor should not have to guess and gamble on something as variable as this item.

- A5. Pavement coring results are provided on the Demolition plans.

- Q6. Paragraph 2 of Section 302-1.6, Cold Milling of Composite Pavements of the Supplementary Special Provisions says "The thickness of all existing pavement material was not know at the time of the project design. Any areas where it is necessary to cold mill to a depth that exceeds the thickness of the existing asphalt paving and extends down to the Portland cement concrete paving, shall be completely demolished and disposed of, per the requirements of "Clearing and Grubbing."

We cannot find what the replacement structural section is to be in these areas, nor what kind of materials are to be used. Neither do we find a method of payment for this work.

What is the structural section for replacement of areas removed under Section 302-1.6 and how is this work paid for?

- A6. Any areas where the existing pavement has been completely removed shall be replaced with a full pavement section of 4" AC on 13.5" CTB per SDG-113. Please refer to the payment reference in the Bid.
- Q7. There are break lines where the "sun rays" touch the outer circle, are these meant to be there? Or is the water jet cut stainless steel part of the emblem all one piece?
- A7. The breaklines are intentional because the stainless steel for the "sun rays" are separate from that of the inner circle.
- Q8. The "GH" letters in the middle are a different color then the rest. Is this a different material to be inset separately?
- A8. The "GH" letters in the middle (small emblem) will be 5/8" thick bronze. See E. Plans, item 2 of this Addendum.

C. CLARIFICATIONS

1. The improvement plans do not show any locations where engraved donor brick pavers are to be used. Bid Item 29, Interlocking Concrete Pavers is to be constructed with only normal interlocking concrete pavers. See E. Plans, item 1 of this Addendum.

D. VOLUME 1

1. To the Supplementary Special Provisions, Section 300 – Earthwork, **ADD** the following:

300-1.1 General. ADD the following:

Prior to submittal of a Bid for this Work, the Contractor shall inspect the project site to verify the magnitude and cost of all clearing and grubbing required to accomplish the Work.

Clearing and grubbing shall also include saw cutting, demolition, removal, and disposal of all existing improvements (up to 22”) including, but not limited to, soil, pavement (Asphalt Concrete, Base, Unclassified Materials), curb and gutter, buried trolley tracks, abandoned utilities and utility structures (pull boxes, etc.), and all other existing improvements that are shown on the plans for removal, directed by the Resident Engineer to be removed, or otherwise required to perform the work.

2. To the Supplementary Special Provisions, Section 300 - Earthwork, Page 38, Sub-section 300-1.4, “Payment”, **DELETE** in its entirety and **SUBSTITUTE** with the following:

300-1.4 Payment. To the City Supplement, **DELETE** the first five paragraphs in this section and **ADD** the following:

7. The lump sum price paid for Clearing and Grubbing shall include full compensation for the sawcutting, removal, protection, and disposal of any and all PCC Pavement, AC Pavement, Base Material, soil, driveway, sidewalk, curb & gutter, buried trolley tracks, median, bollards, street light foundation, landscaping, irrigation, and any other materials and objects that are in conflict with the installation of the Work as shown on the Plans.

3. To the Supplementary Special Provisions, **ADD** the following:

SECTION 307 – STREET LIGHTING AND TRAFFIC SIGNAL SYSTEMS

307-2 Payment. To the City Supplement, **ADD** the following:

4. The contract Lump Sum price paid for the Traffic Signal Modifications shall include full compensation for removal and salvaging of existing equipment, furnishing and installing street light and traffic signal standards, posts and pedestals, vehicle detector loops, signal & lighting electrical service and switches, luminaires, lamps, ballasts, electrical conduits, conductors and cable, pull boxes, signal heads, city furnished emergency vehicle preemption equipment, installation of city furnished controller assembly, central control unit, and a conflict monitor unit, and other such items as required on the Plans or these Special Provisions, except for Work covered in separate bid items, and no additional compensation will be allowed.
5. Relocate Decorative Street Lights shall be paid for at the contract unit price for Each, and shall include full compensation for furnishing all labor, materials, tools,

equipment, and incidentals, and for doing all the work involved in relocating the existing decorative street lights, complete, in place, as shown on the plans and per these Special Provisions, including foundations, new pull boxes, wiring, fuses, and conduits.

E. PLANS

1. To Drawing number 36515-10-D, Sheet C-7, Detail F, Concrete Interlocking Pavers, to note “Engraved Donor Brick Pavers O.F.C.I. See Construction Plan for Locations”, **DELETE** in its entirety.
2. To Drawing number 36515-10-D, Sheet C-7, Detail G, Golden Hill Emblem, to “GH” letters (bottom of emblem), **ADD** the following:

““5/8” THICK BRONZE LETTERS”.

Tony Heinrichs, Director
Public Works Department

Dated: *November 8, 2013*
San Diego, California

TH/BD/egz

City of San Diego

TRI-GROUP CONSTRUCTION
AND DEVELOPMENT, INC.
9580 BLACK MOUNTAIN RD, STE L
SAN DIEGO, CA 92126

CONTRACTOR'S NAME: _____
ADDRESS: _____
TELEPHONE NO.: 858-689-0058 FAX NO.: 858-689-1594
CITY CONTACT: Damian Singleton, Contract Specialist, Email: Dsingleton@sandiego.gov
Phone No. (619) 533-3482, Fax No. (619) 533-3633
DLi/BDoringo/egz

CONTRACT DOCUMENTS



FOR

25TH STREET RENAISSANCE PROJECT

VOLUME 2 OF 2

BID NO.: _____ K-14-5524-DBB-3
SAP NO. (WBS/IO/CC): _____ S-00985, B-12016
CLIENT DEPARTMENT: _____ 2113, 2013
COUNCIL DISTRICT: _____ 3
PROJECT TYPE: _____ IG, KB
FEDERAL AID PROJECT NO.: _____ RPSTPLE 5004(176)

THIS CONTRACT IS SUBJECT TO THE FOLLOWING:

- THE CITY'S SUBCONTRACTING PARTICIPATION REQUIREMENTS FOR SLBE PROGRAM.
- PREVAILING WAGE RATES: STATE FEDERAL

THIS BIDDING DOCUMENT TO BE SUBMITTED IN ITS ENTIRETY
REFER TO VOLUME 1 COVER PAGE FOR TIME, DATE, AND LOCATION

TABLE OF CONTENTS

Volume 2 - Bidding Documents

The following forms must be completed in their entirety and submitted with the Bid. Include the form(s) even if the information does not apply. Where the information does not apply write in N/A. Failure to include any of the forms may cause the Bid to be deemed **non-responsive**. If you are uncertain or have any questions about any required information, contact the City no later than 14 days prior to Bid due date.

1. Bid/Proposal.....	4
2. Bid Bond.....	7
3. Non-Collusion Affidavit to be executed by Bidder and Submitted with Bid under 23 USC 112 and PCC 7106.....	8
4. Contractors Certification of Pending Actions.....	9
5. Equal Benefits Ordinance Certification of Compliance.....	10
6. Proposal (Bid).....	11
7. Form AA35 - List of Subcontractors.....	17
8. Form AA40 - Named Equipment/Material Supplier List.....	18
9. Form AA45 - Subcontractors Additive/Deductive Alternate.....	19

PROPOSAL

Bidder's General Information

To the City of San Diego:

Pursuant to "Notice Inviting Bids", specifications, and requirements on file with the City Clerk, and subject to all provisions of the Charter and Ordinances of the City of San Diego and applicable laws and regulations of the United States and the State of California, the undersigned hereby proposes to furnish to the City of San Diego, complete at the prices stated herein, the items or services hereinafter mentioned. The undersigned further warrants that this bid is not made in the interest of, or on behalf of, any undisclosed person, partnership, company, association, organization, or corporation; that the bid is genuine and not collusive or sham; that the bidder has not directly or indirectly induced or solicited any other bidder to put in a false or sham bid, and has not directly or indirectly colluded, conspired, connived, or agreed with any bidder or anyone else to put in a sham bid, or that anyone shall refrain from bidding; that the bidder has not in any manner, directly or indirectly, sought by agreement, communication, or conference with anyone to fix the bid price of the bidder or any other bidder, or to fix any overhead, profit, or cost element of the bid price, or of that of any other bidder, or to secure any advantage against the public body awarding the contract of anyone interested in the proposed contract; that all statements contained in the bid are true; and, further, that the bidder has not, directly or indirectly, submitted his or her bid price or any breakdown thereof, or the contents thereof, or divulged information or data relative thereto, or paid, and will not pay, any fee to any corporation, partnership, company, association, organization, bid depository, or to any member or agent thereof to effectuate a collusive or sham bid.

The undersigned bidder(s) further warrants that bidder(s) has thoroughly examined and understands the entire Contract Documents (plans and specifications) and the Bidding Documents therefore, and that by submitting said Bidding Documents as its bid proposal, bidder(s) acknowledges and is bound by the entire Contract Documents, including any addenda issued thereto, as such Contract Documents incorporated by reference in the Bidding Documents.

IF A SOLE OWNER OR SOLE CONTRACTOR SIGN HERE:

(N/A)

- (1) Name under which business is conducted _____
- (2) Signature (Given and surname) of proprietor _____
- (3) Place of Business (Street & Number) _____
- (4) City and State _____ Zip Code _____
- (5) Telephone No. _____ Facsimile No. _____

IF A PARTNERSHIP, SIGN HERE:

(N/A)

- (1) Name under which business is conducted _____

BIDDING DOCUMENTS

(2) Name of each member of partnership, indicate character of each partner, general or special (limited):

(3) Signature (Note: Signature must be made by a general partner)

Full Name and Character of partner

(4) Place of Business (Street & Number) _____

(5) City and State _____ Zip Code _____

(6) Telephone No. _____ Facsimile No. _____

IF A CORPORATION, SIGN HERE:

**TRI-GROUP
CONSTRUCTION AND
DEVELOPMENT, INC.**

(1) Name under which business is conducted _____

(2) Signature, with official title of officer authorized to sign for the corporation:

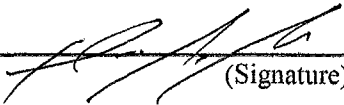

(Signature)

HANI ASSI

(Printed Name)

SECRETARY OF CORPORATION

(Title of Officer)

(Impress Corporate Seal Here)

(3) Incorporated under the laws of the State of CALIFORNIA

(4) Place of Business (Street & Number) 9580 BLACK MTN RD SUITE "L"

(5) City and State SAN DIEGO CA Zip Code 92126

(6) Telephone No. 858-689-0058 Facsimile No. 858-689-1594

BIDDING DOCUMENTS

THE FOLLOWING SECTIONS MUST BE FILLED IN BY ALL PROPOSERS:

In accordance with the "NOTICE INVITING BIDS", the bidder holds a California State Contractor's license for the following classification(s) to perform the work described in these specifications:

LICENSE CLASSIFICATION "A"
LICENSE NO. 792159 EXPIRES 03-31-2015

This license classification must also be shown on the front of the bid envelope. Failure to show license classification on the bid envelope may cause return of the bid unopened.

TAX IDENTIFICATION NUMBER (TIN): [REDACTED]

E-Mail Address: trigroupconst@aol.com

BIDDING DOCUMENTS

THIS PROPOSAL MUST BE NOTARIZED BELOW:

I certify, under penalty of perjury, that the representations made herein regarding my State Contractor's license number, classification and expiration date are true and correct.

HANI ASSI

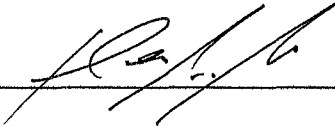
Signature  Title _____
SECRETARY OF CORPORATION

SUBSCRIBED AND SWORN TO BEFORE ME, THIS 30th DAY OF October, 2013

Notary Public in and for the County of San Diego, State of California

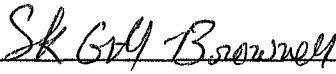
(NOTARIAL SEAL)

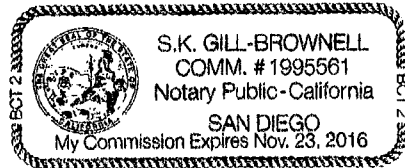

BIDDING DOCUMENTS

BID BOND

KNOW ALL MEN BY THESE PRESENTS,

That TRI-GROUP CONSTRUCTION AND DEVELOPMENT, INC. as Principal, and NORTH AMERICAN SPECIALTY INSURANCE COMPANY as Surety, are held and firmly bound unto The City of San Diego hereinafter called "OWNER," in the sum of **10% OF THE TOTAL BID AMOUNT** for the payment of which sum, well and truly to be made, we bind ourselves, our heirs, executors, administrators, successors, and assigns, jointly and severally, firmly by these presents.

WHEREAS, said Principal has submitted a Bid to said OWNER to perform the WORK required under the bidding schedule(s) of the OWNER's Contract Documents entitled

25TH STREET RENAISSANCE PROJECT, BID NO. K-14-5524-DBB-3

NOW THEREFORE, if said Principal is awarded a contract by said OWNER and, within the time and in the manner required in the "Notice Inviting Bids" enters into a written Agreement on the form of agreement bound with said Contract Documents, furnishes the required certificates of insurance, and furnishes the required Performance Bond and Payment Bond, then this obligation shall be null and void, otherwise it shall remain in full force and effect. In the event suit is brought upon this bond by said OWNER and OWNER prevails, said Surety shall pay all costs incurred by said OWNER in such suit, including a reasonable attorney's fee to be fixed by the court.

SIGNED AND SEALED, this 22ND day of NOVEMBER, 20 13

TRI-GROUP CONSTRUCTION AND DEVELOPMENT, INC. (SEAL)
(Principal)

NORTH AMERICAN SPECIALTY INSURANCE COMPANY (SEAL)
(Surety)

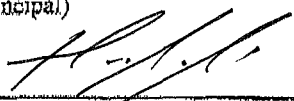
By: 
(Signature)
HANI ASSI, SECRETARY

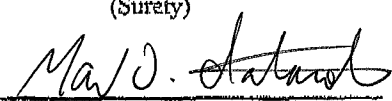
By: 
(Signature)
MARK D. IATAROLA, ATTORNEY-IN-FACT

(SEAL AND NOTARIAL ACKNOWLEDGEMENT OF SURETY)

CALIFORNIA ALL-PURPOSE ACKNOWLEDGMENT

STATE OF CALIFORNIA

County of SAN DIEGO }

On 11/22/2013 before me, MICHELLE M. BASUIL, NOTARY PUBLIC,
Date Here Insert Name and Title of the Officer

personally appeared MARK D. IATAROLA
Name(s) of Signer(s)

who proved to me on the basis of satisfactory evidence to be the person(~~s~~) whose name(~~s~~) is/~~are~~ subscribed to the within instrument and acknowledged to me that he/~~she/they~~ executed the same in his/~~her/their~~ authorized capacity(~~ies~~), and that by his/~~her/their~~ signature(~~s~~) on the instrument the person(~~s~~), or the entity upon behalf of which the person(~~s~~) acted, executed the instrument.

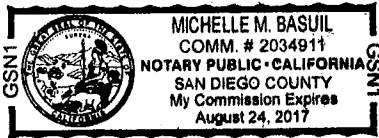

Place Notary Seal Above

I certify under PENALTY OF PERJURY under the laws of the State of California that the foregoing paragraph is true and correct.

Witness my hand and official seal.

Signature Michelle M. Basuil
Signature of Notary Public

OPTIONAL

Though the information below is not required by law, it may prove valuable to persons relying on the document and could prevent fraudulent removal and reattachment of this form to another document.

Description of Attached Document

Title or Type of Document: BID BOND

Document Date: 11/22/2013 Number of Pages: 1

Signer(s) Other Than Named Above: _____

Capacity(ies) Claimed by Signer(s)

Signer's Name: MARK D. IATAROLA

- Individual
- Corporate Officer — Title(s): _____
- Partner — Limited General
- Attorney in Fact
- Trustee
- Guardian or Conservator
- Other: _____

Signer Is Representing: _____

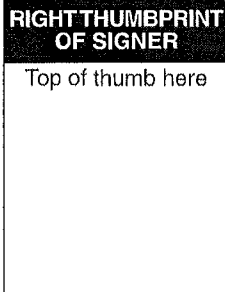

Signer's Name: _____

- Individual
- Corporate Officer — Title(s): _____
- Partner — Limited General
- Attorney in Fact
- Trustee
- Guardian or Conservator
- Other: _____

Signer Is Representing: _____

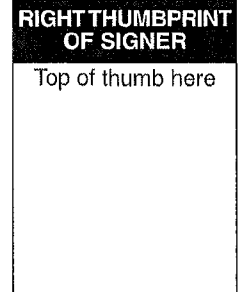

NAS SURETY GROUP

NORTH AMERICAN SPECIALTY INSURANCE COMPANY
WASHINGTON INTERNATIONAL INSURANCE COMPANY

GENERAL POWER OF ATTORNEY

KNOW ALL MEN BY THESE PRESENTS, THAT North American Specialty Insurance Company, a corporation duly organized and existing under laws of the State of New Hampshire, and having its principal office in the City of Manchester, New Hampshire, and Washington International Insurance Company, a corporation organized and existing under the laws of the State of New Hampshire and having its principal office in the City of Schaumburg, Illinois, each does hereby make, constitute and appoint:

JOHN G. MALONEY, HELEN MALONEY, MICHELLE M. BASUIL,
GLEND A. J. GARDNER, MARK D. IATAROLA and DEBORAH D. DAVIS

JOINTLY OR SEVERALLY

Its true and lawful Attorney(s)-in-Fact, to make, execute, seal and deliver, for and on its behalf and as its act and deed, bonds or other writings obligatory in the nature of a bond on behalf of each of said Companies, as surety, on contracts of suretyship as are or may be required or permitted by law, regulation, contract or otherwise, provided that no bond or undertaking or contract or suretyship executed under this authority shall exceed the amount of:

FIFTY MILLION (\$50,000,000.00) DOLLARS

This Power of Attorney is granted and is signed by facsimile under and by the authority of the following Resolutions adopted by the Boards of Directors of both North American Specialty Insurance Company and Washington International Insurance Company at meetings duly called and held on the 9th of May, 2012:

"RESOLVED, that any two of the Presidents, any Managing Director, any Senior Vice President, any Vice President, any Assistant Vice President, the Secretary or any Assistant Secretary be, and each or any of them hereby is authorized to execute a Power of Attorney qualifying the attorney named in the given Power of Attorney to execute on behalf of the Company bonds, undertakings and all contracts of surety, and that each or any of them hereby is authorized to attest to the execution of any such Power of Attorney and to attach therein the seal of the Company; and it is

FURTHER RESOLVED, that the signature of such officers and the seal of the Company may be affixed to any such Power of Attorney or to any certificate relating thereto by facsimile, and any such Power of Attorney or certificate bearing such facsimile signatures or facsimile seal shall be binding upon the Company when so affixed and in the future with regard to any bond, undertaking or contract of surety to which it is attached."



By [Signature]
Steven P. Anderson, Senior Vice President of Washington International Insurance Company
& Senior Vice President of North American Specialty Insurance Company



By [Signature]
David M. Layman, Vice President of Washington International Insurance Company
& Vice President of North American Specialty Insurance Company

IN WITNESS WHEREOF, North American Specialty Insurance Company and Washington International Insurance Company have caused their official seals to be hereunto affixed, and these presents to be signed by their authorized officers this 10th day of December, 2012.

North American Specialty Insurance Company
Washington International Insurance Company

State of Illinois
County of Cook ss:

On this 10th day of December, 2012, before me, a Notary Public personally appeared Steven P. Anderson, Senior Vice President of Washington International Insurance Company and Senior Vice President of North American Specialty Insurance Company and David M. Layman, Vice President of Washington International Insurance Company and Vice President of North American Specialty Insurance Company, personally known to me, who being by me duly sworn, acknowledged that they signed the above Power of Attorney as officers of and acknowledged said instrument to be the voluntary act and deed of their respective companies.



[Signature]
Donna D. Sklens, Notary Public

I, Jeffrey Goldberg, the duly elected Assistant Secretary of North American Specialty Insurance Company and Washington International Insurance Company, do hereby certify that the above and foregoing is a true and correct copy of a Power of Attorney given by said North American Specialty Insurance Company and Washington International Insurance Company, which is still in full force and effect.

IN WITNESS WHEREOF, I have set my hand and affixed the seals of the Companies this 22nd day of NOVEMBER, 2013.

[Signature]
Jeffrey Goldberg, Vice President & Assistant Secretary of
Washington International Insurance Company & North American Specialty Insurance Company

NON-COLLUSION AFFIDAVIT TO BE EXECUTED BY BIDDER AND SUBMITTED WITH BID UNDER 23 UNITED STATES CODE 112 AND PUBLIC CONTRACT CODE 7106

State of California)
County of SAN DIEGO) ss.
HANI ASSI

being first duly sworn, deposes and says that he or she is SECRETARY OF CORPORATION of the party making the foregoing bid that the bid is not made in the interest of, or on behalf of, any undisclosed person, partnership, company, association, organization, or corporation; that the bid is genuine and not collusive or sham; that the bidder has not directly or indirectly induced or solicited any other bidder to put in a false or sham bid, and has not directly or indirectly colluded, conspired, connived, or agreed with any bidder or anyone else to put in a sham bid, or that anyone shall refrain from bidding; that the bidder has not in any manner, directly or indirectly, sought by agreement, communication, or conference with anyone to fix the bid price of the bidder or any other bidder, or to fix any overhead, profit, or cost element of the bid price, or of that of any other bidder, or to secure any advantage against the public body awarding the contract of anyone interested in the proposed contract; that all statements contained in the bid are true; and further, that the bidder has not, directly or indirectly, submitted his or her bid price or any breakdown thereof, or the contents thereof, or divulged information or data relative thereto, or paid, and will not pay, any fee to any corporation, partnership, company association, organization, bid depository, or to any member or agent thereof to effectuate a collusive or sham bid.

Signed: [Signature] HANI ASSI
Title: SECRETARY OF CORPORATION

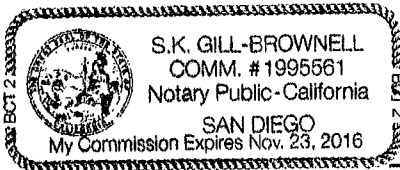

Subscribed and sworn to before me this 30th day of October, 2013
[Signature]
Notary Public

(SEAL)

CONTRACTORS CERTIFICATION OF PENDING ACTIONS

As part of its bid or proposal (Non-Price Proposal in the case of Design-Build contracts), the Bidder shall provide to the City a list of all instances within the past 10 years where a complaint was filed or pending against the Bidder in a legal or administrative proceeding alleging that Bidder discriminated against its employees, subcontractors, vendors or suppliers, and a description of the status or resolution of that complaint, including any remedial action taken.

CHECK ONE BOX ONLY.

- The undersigned certifies that within the past 10 years the Bidder has NOT been the subject of a complaint or pending action in a legal administrative proceeding alleging that Bidder discriminated against its employees, subcontractors, vendors or suppliers.

- The undersigned certifies that within the past 10 years the Bidder has been the subject of a complaint or pending action in a legal administrative proceeding alleging that Bidder discriminated against its employees, subcontractors, vendors or suppliers. A description of the status or resolution of that complaint, including any remedial action taken and the applicable dates is as follows:

DATE OF CLAIM	LOCATION	DESCRIPTION OF CLAIM	LITIGATION (Y/N)	STATUS	RESOLUTION/REMEDIAL ACTION TAKEN
		TRI-GROUP CONSTRUCTION AND DEVELOPMENT, INC.			HANI ASSI <i>HA</i>

Contractor Name: _____

Certified By *HANI ASSI* Title **SECRETARY OF CORPORATION**
Name
 [Signature] Date 10-31-2013
Signature

USE ADDITIONAL FORMS AS NECESSARY

BIDDING DOCUMENTS

**EQUAL BENEFITS ORDINANCE
CERTIFICATION OF COMPLIANCE**



For additional information, contact:
CITY OF SAN DIEGO
EQUAL BENEFITS PROGRAM
 202 C Street, MS 9A, San Diego, CA 92101
 Phone (619) 533-3948 Fax (619) 533-3220

COMPANY INFORMATION

Company Name:	TRI-GROUP CONSTRUCTION AND DEVELOPMENT, INC.	Contact Name:	HANI ASSI
Company Address:	9580 BLACK MOUNTAIN RD, STE L SAN DIEGO, CA 92126	Contact Phone:	858-689-0558
		Contact Email:	trigroupconst@aol.com

CONTRACT INFORMATION

Contract Title:	25th STREET RENAISSANCE	Start Date:	02-15-14
Contract Number (if no number, state location):	BID No K-14-5504-DBB-3	End Date:	09-15-14

SUMMARY OF EQUAL BENEFITS ORDINANCE REQUIREMENTS

The Equal Benefits Ordinance [EBO] requires the City to enter into contracts only with contractors who certify they will provide and maintain equal benefits as defined in SDMC §22.4302 for the duration of the contract. To comply:

- Contractor shall offer equal benefits to employees with spouses and employees with domestic partners.
 - Benefits include health, dental, vision insurance; pension/401(k) plans; bereavement, family, parental leave; discounts, child care; travel/relocation expenses; employee assistance programs; credit union membership; or any other benefit.
 - Any benefit not offer an employee with a spouse, is not required to be offered to an employee with a domestic partner.
- Contractor shall post notice of firm's equal benefits policy in the workplace and notify employees at time of hire and during open enrollment periods.
- Contractor shall allow City access to records, when requested, to confirm compliance with EBO requirements.
- Contractor shall submit *EBO Certification of Compliance*, signed under penalty of perjury, prior to award of contract.

NOTE: This summary is provided for convenience. Full text of the EBO and Rules Implementing the EBO are available at www.sandiego.gov/administration.

CONTRACTOR EQUAL BENEFITS ORDINANCE CERTIFICATION

Please indicate your firm's compliance status with the EBO. The City may request supporting documentation.

- I affirm **compliance** with the EBO because my firm (*contractor must select one reason*):
- Provides equal benefits to spouses and domestic partners.
 - Provides no benefits to spouses or domestic partners.
 - Has no employees.
 - Has collective bargaining agreement(s) in place prior to January 1, 2011, that has not been renewed or expired.
- I request the City's approval to pay affected employees a cash equivalent in lieu of equal benefits and verify my firm made a reasonable effort but is not able to provide equal benefits upon contract award. I agree to notify employees of the availability of a cash equivalent for benefits available to spouses but not domestic partners and to continue to make every reasonable effort to extend all available benefits to domestic partners.

It is unlawful for any contractor to knowingly submit any false information to the City regarding equal benefits or cash equivalent associated with the execution, award, amendment, or administration of any contract. [San Diego Municipal Code §22.4307(a)]

Under penalty of perjury under laws of the State of California, I certify the above information is true and correct. I further certify that my firm understands the requirements of the Equal Benefits Ordinance and will provide and maintain equal benefits for the duration of the contract or pay a cash equivalent if authorized by the City.

HANI ASSI SECRETARY OF CORP.

Name/Title of Signatory Signature

FOR OFFICIAL CITY USE ONLY

Receipt Date:	EBO Analyst:	<input type="checkbox"/> Approved	<input type="checkbox"/> Not Approved – Reason:
---------------	--------------	-----------------------------------	---

BIDDING DOCUMENTS

PROPOSAL (BID)

The Bidder agrees to the construction of **25th Street Renaissance Project**, for the City of San Diego, in accordance with these contract documents for the prices listed below. The Bidder guarantees the Contract Price for a period of 120 days (90 days for federally funded contracts and contracts valued at \$500,000 or less) from the date of Bid opening to Award of the Contract. The duration of the Contract Price guarantee shall be extended by the number of days required for the City to obtain all items necessary to fulfill all conditions precedent e.g., bond and insurance.

Item	Quantity	Unit	NAICS	Payment Reference	Description	Unit Price	Extension
BASE BID							
25TH STREET RENAISSANCE							
1.	1	LS	524126	2-4.1	Bond (Payment and Performance)	 	\$
2.	1	AL	532490	7-10.1.1.1	Reimbursement for Trailers – Type I	 	\$10,000.00
3.	1	LS	237310	7-10.2.7	Traffic Control	 	\$
4.	6	EA	238210	9-3.1	Remove and Salvage Existing Traffic Sign	\$	\$
5.	39	EA	238210	9-3.1	Relocate Existing Sign	\$	\$
6.	1	LS	238910	9-3.1	Remove and Reinstall Site Furnishings (Including Bus Shelter)	 	\$
7.	1	LS	237310	9-3.4.1	Mobilization	 	\$
8.	1	AL		9-3.5	Field Orders - Type II	 	\$80,000.00
9.	1	LS	238910	300-1.4	Clearing and Grubbing	 	\$
10.	4	EA	238910	300-1.4	Tree Removal	\$	\$
11.	1	LS	237310	301-1.7	Adjust Utilities to Grade	 	\$
12.	1,405	CY	237310	301-3.3.6	Cement Treated Base	\$	\$
13.	44,220	SF	237310	302-1.12	2" Cold Mill Asphalt Pavement	\$	\$
14.	787	TN	237310	302-5.9	4" Asphalt Concrete Pavement	\$	\$
15.	516	TN	237310	302-5.9	2" Asphalt Overlay	\$	\$
16.	1,200	SF	237310	302-6.8	Bus Stop Slab	\$	\$

BIDDING DOCUMENTS

Item	Quantity	Unit	NAICS	Payment Reference	Description	Unit Price	Extension
17.	16	LF	237110	303-1.12.2	Trench Drain and Cover Grates	\$	\$
18.	6	EA	237310	303-5.5.3.2	Decorative Emblems	\$	\$
19.	10	EA	237310	303-5.9	Relocate Contractor Date Stamps and Impressions	\$	\$
20.	2,260	LF	237310	303-5.9	Curb & Gutter, Type G	\$	\$
21.	3,750	SF	237310	303-5.9	Cross Gutter, per SDG-157	\$	\$
22.	1,255	SF	237310	303-5.9	Alley Apron, per SDG-120	\$	\$
23.	750	SF	237310	303-5.9	Driveway, per SDG-159	\$	\$
24.	525	SF	237310	303-5.9	Driveway, per SDG-160	\$	\$
25.	90	LF	237310	303-5.9	Median Curb, Type B-1, per SDG-154	\$	\$
26.	21,750	SF	237310	303-5.9	PCC Sidewalk	\$	\$
27.	850	LF	237310	303-5.9	Concrete Band, 12" Wide	\$	\$
28.	225	LF	237310	303-5.9	Concrete Band, 24" Wide	\$	\$
29.	3,675	SF	237310	303-9.2	Interlocking Concrete Pavers	\$	\$
30.	12	EA	237310	303-5.10.2	Curb Ramp Type A with Stainless Steel Detectable Warning Tiles	\$	\$
31.	8	EA	237310	303-5.10.2	Curb Ramp Type D with Stainless Steel Detectable Warning Tiles	\$	\$
32.	2	EA	237310	303-5.10.2	Curb Ramp Case A with Stainless Steel Detectable Warning Tiles	\$	\$
33.	20	LF	237110	306-1.6	Sidewalk Underdrain, per D-27	\$	\$
34.	9	EA	238210	307-2	Relocate Decorative Street Lights	\$	\$
35.	1	LS	238210	307-2	Traffic Signal Modification	\$	\$
36.	34	EA	238210	307-2	Install Traffic Sign On Post	\$	\$
37.	3,850	LF	237310	314-4.3.7	Painted Traffic Stripes	\$	\$

BIDDING DOCUMENTS

Item	Quantity	Unit	NAICS	Payment Reference	Description	Unit Price	Extension
38.	600	SF	237310	314-4.3.7	Painted Pavement Markings	\$	\$
39.	400	LF	237310	314-4.3.7	Painted Curb Markings	\$	\$
40.	10,100	LF	237310	314-4.4.6	Thermoplastic Traffic Stripes	\$	\$
41.	725	SF	237310	314-4.4.6	Thermoplastic Pavement Markings	\$	\$
42.	240	EA	237310	314-5.6	Pavement Markers (Retroreflective and Non-retroreflective)	\$	\$
43.	2	EA	237110	701-13.8.4	Storm Water Treatment Basins	\$	\$
44.	1	LS	541330	701-13.8.4	Water Pollution Control Program Development	 	\$
45.	1	LS	237990	701-13.8.4	Water Pollution Control Program Implementation	 	\$
46.	1	LS	541330	701-13.8.4	Permit Fee	 	\$
WATER GROUP JOB 960							
47.	1	LS	524126	2-4.1	Bonds (Payment and Performance)	 	\$
48.	1	EA	541214	3-3.2.2.1	Certified Payroll	\$	\$
49.	1	LS	238990	7-9.1.1	Video Recording of Pre-existing Conditions	 	\$
50.	1	LS	237110	9-3.4.1	Mobilization	 	\$
51.	1	AL		9-3.5	Field Orders - Type II	 	\$15,000.00
52.	1,000	SF	237310	302-5.2.1	Pavement Restoration Adjacent to Trench	\$	\$
53.	3	EA	237310	303-5.10.2	Curb Ramp Type A with Stainless Steel Detectable Warning Tiles	\$	\$
54.	1	LS	237110	306-1.1.6	Trench Shoring	 	\$
55.	50	CY	237110	306-1.2.1.1	Additional Bedding	\$	\$
56.	45	TON	237310	306-1.5.1	Temporary Resurfacing	\$	\$
57.	100	TON	237110	306-1.6	Imported Backfill	\$	\$

BIDDING DOCUMENTS

Item	Quantity	Unit	NAICS	Payment Reference	Description	Unit Price	Extension	
58.	41	LF	237110	306-1.6	12-Inch Water Main	\$	\$	
59.	1,141	LF	237110	306-1.6	16-Inch Water Main	\$	\$	
60.	9	CY	237110	306-1.6	Thrust Anchor	\$	\$	
61.	1	EA	237110	306-1.6	4-Inch Fire Service Connection & Assembly	\$	\$	
62.	2	EA	237110	306-1.6	6-Inch Fire Hydrant Assembly & Marker	\$	\$	
63.	4	EA	237110	306-1.6	16-Inch Butterfly Valve Class 250B	\$	\$	
64.	2	EA	237110	306-1.6	12-Inch Gate Valve	\$	\$	
65.	15	EA	237110	306-14.1	1-Inch Water Service	\$	\$	
66.	2	EA	237110	306-14.1	2-Inch Copper Water Service	\$	\$	
67.	3	EA	237110	306-5.3	Remove and Cap Abandoned Water Meter Box	\$	\$	
68.	2,400	LF	237110	600-1.2.1.3	High-lining Removed by Contractor	\$	\$	
69.	24	EA	237110	600-1.2.1.3	Water Service Transfer from Highline	\$	\$	
70.	1	LS	237110	600-1.3.1.5	Contractor Furnished Materials for City Forces Connection and Cut-in Work for Mains 16-inch and Larger	X	\$	
71.	250	SF	237110	600-1.3.1.5	Pavement Restoration for City Forces Final Connection	\$	\$	
72.	41	LF	237110	708-6	Handling and Disposal of Non-friable Asbestos Material	\$	\$	
ESTIMATED TOTAL BASE BID:							\$	\$
ALTERNATE A								
1.	-2,400	LF	237110	600-1.2.1.3	High-lining Removed by the Contractor (Base Bid Item 68)	\$	\$	
2.	1	LS	237110	600-1.3.2.10	High-lining by Contractor	X	\$	
ESTIMATED TOTAL ALTERNATE A:							\$	\$

BIDDING DOCUMENTS

Item	Quantity	Unit	NAICS	Payment Reference	Description	Unit Price	Extension	
ALTERNATE B								
1.	-250	SF	237110	600-1.3.1.5	Pavement Restoration for City Forces Final Connection (Base Bid Item 71)	\$	\$	
2.	1	EA	237110	600-1.3.2.10	8-Inch through 16-Inch Connections to The Existing System by Contractor	\$	\$	
3.	2	EA	237110	600-1.4.9	Cut and Plug of The Existing System by Contractor	\$	\$	
ESTIMATED TOTAL ALTERNATE B:							\$	\$
ESTIMATED TOTAL BASE BID PLUS ALTERNATE A PLUS ALTERNATE B:							\$	\$

TOTAL BID PRICE FOR BID (Items 1 through 72 Plus Alternate A, item 1 through 2 Plus Alternate B, item 1 through 3, inclusive) amount written in words:

The Bid shall contain an acknowledgment of receipt of all addenda, the numbers of which shall be filled in on the Bid form. If an addendum or addenda has been issued by the City and not noted as being received by the Bidder, this proposal shall be rejected as being **non-responsive**. The following addenda have been received and are acknowledged in this bid: ADDENDUM 'A'

The names of all persons interested in the foregoing proposal as principals are as follows:

GUS ASSI HANI ASSI
PRESIDENT +
SECRETARY OF CORPORATION

IMPORTANT NOTICE: If Bidder or other interested person is a corporation, state secretary, treasurer, and manager thereof; if a co-partnership, state true name of firm, also names of all individual co-partners composing firm; if Bidder or other interested person is an individual, state first and last names in full.

BIDDING DOCUMENTS

Bidder: TRI-GROUP CONSTRUCTION AND DEVELOPMENT, INC. HANI ASSI

Title: SECRETARY OF CORPORATION

Business Address: _____

Place of Business: CITY OF SAN DIEGO

Place of Residence: CITY OF SAN DIEGO

Signature: [Handwritten Signature]

NOTES:

- A. The City shall determine the low Bid based on the Base Bid Plus Alternates A and B.
- B. After the low Bid has been determined, the City may award the Contract for the Base Bid alone or if applicable, for the Base Bid plus any combination of alternates selected in the City's sole discretion.
- C. Prices and notations shall be in ink or typewritten. All corrections (which have been initiated by the Bidder using erasures, strike out, line out, or "white-out") shall be typed or written in with ink adjacent thereto, and shall be initialed in ink by the person signing the bid proposal.
- D. Failure to initial all corrections made in the bidding documents shall cause the Bid to be rejected as **non-responsive** and ineligible for further consideration.
- E. Blank spaces must be filled in, using figures. Bidder's failure to submit a price for any Bid item that requires the Bidder to submit a price shall render the Bid **non-responsive** and shall be cause for its rejection.
- F. Unit prices shall be entered for all unit price items. Unit prices shall not exceed two (2) decimal places. If the Unit prices entered exceed two (2) decimal places, the City will only use the first two digits after the decimal points without rounding up or down.
- G. All extensions of the unit prices bid will be subject to verification by the City. In the case of inconsistency or conflict between the product of the Quantity x Unit Price and the Extension, the product shall govern.
- H. In the case of inconsistency or conflict, between the sums of the Extensions with the estimated total Bid, the sum of the Extensions shall govern.
- I. Bids shall not contain any recapitulation of the Work. Conditional Bids will be rejected as being **non-responsive**. Alternative proposals will not be considered unless called for.

BIDDING DOCUMENTS

PROPOSAL (BID)

The Bidder agrees to the construction of **25th Street Renaissance Project**, for the City of San Diego, in accordance with these contract documents for the prices listed below. The Bidder guarantees the Contract Price for a period of 120 days (90 days for federally funded contracts and contracts valued at \$500,000 or less) from the date of Bid opening to Award of the Contract. The duration of the Contract Price guarantee shall be extended by the number of days required for the City to obtain all items necessary to fulfill all conditions precedent e.g., bond and insurance.

Item	Quantity	Unit	NAICS	Payment Reference	Description	Unit Price	Extension
BASE BID							
25TH STREET RENAISSANCE							
1.	1	LS	524126	2-4.1	Bond (Payment and Performance)	 	\$
2.	1	AL	532490	7-10.1.1.1	Reimbursement for Trailers – Type I	 	\$10,000.00
3.	1	LS	237310	7-10.2.7	Traffic Control	 	\$
4.	6	EA	238210	9-3.1	Remove and Salvage Existing Traffic Sign	\$	\$
5.	39	EA	238210	9-3.1	Relocate Existing Sign	\$	\$
6.	1	LS	238910	9-3.1	Remove and Reinstall Site Furnishings (Including Bus Shelter)	 	\$
7.	1	LS	237310	9-3.4.1	Mobilization	 	\$
8.	1	AL		9-3.5	Field Orders - Type II	 	\$80,000.00
9.	1	LS	238910	300-1.4	Clearing and Grubbing	 	\$
10.	4	EA	238910	300-1.4	Tree Removal	\$	\$
11.	1	LS	237310	301-1.7	Adjust Utilities to Grade	 	\$
12.	1,405	CY	237310	301-3.3.6	Cement Treated Base	\$	\$
13.	44,220	SF	237310	302-1.12	2" Cold Mill Asphalt Pavement	\$	\$
14.	787	TN	237310	302-5.9	4" Asphalt Concrete Pavement	\$	\$
15.	516	TN	237310	302-5.9	2" Asphalt Overlay	\$	\$
16.	1,200	SF	237310	302-6.8	Bus Stop Slab	\$	\$

BIDDING DOCUMENTS

Item	Quantity	Unit	NAICS	Payment Reference	Description	Unit Price	Extension
17.	16	LF	237110	303-1.12.2	Trench Drain and Cover Grates	\$	\$
18.	6	EA	237310	303-5.5.3.2	Decorative Emblems	\$	\$
19.	10	EA	237310	303-5.9	Relocate Contractor Date Stamps and Impressions	\$	\$
20.	2,260	LF	237310	303-5.9	Curb & Gutter, Type G	\$	\$
21.	3,750	SF	237310	303-5.9	Cross Gutter, per SDG-157	\$	\$
22.	1,255	SF	237310	303-5.9	Alley Apron, per SDG-120	\$	\$
23.	750	SF	237310	303-5.9	Driveway, per SDG-159	\$	\$
24.	525	SF	237310	303-5.9	Driveway, per SDG-160	\$	\$
25.	90	LF	237310	303-5.9	Median Curb, Type B-1, per SDG-154	\$	\$
26.	21,750	SF	237310	303-5.9	PCC Sidewalk	\$	\$
27.	850	LF	237310	303-5.9	Concrete Band, 12" Wide	\$	\$
28.	225	LF	237310	303-5.9	Concrete Band, 24" Wide	\$	\$
29.	3,675	SF	237310	303-9.2	Interlocking Concrete Pavers	\$	\$
30.	12	EA	237310	303-5.10.2	Curb Ramp Type A with Stainless Steel Detectable Warning Tiles	\$	\$
31.	8	EA	237310	303-5.10.2	Curb Ramp Type D with Stainless Steel Detectable Warning Tiles	\$	\$
32.	2	EA	237310	303-5.10.2	Curb Ramp Case A with Stainless Steel Detectable Warning Tiles	\$	\$
33.	20	LF	237110	306-1.6	Sidewalk Underdrain, per D-27	\$	\$
34.	13	EA	238210	307-2	Relocate Decorative Street Lights	\$	\$
35.	1	LS	238210	307-2	Traffic Signal Modification	\$	\$
36.	34	EA	238210	307-2	Install Traffic Sign On Post	\$	\$
37.	3,850	LF	237310	314-4.3.7	Painted Traffic Stripes	\$	\$

BIDDING DOCUMENTS

Item	Quantity	Unit	NAICS	Payment Reference	Description	Unit Price	Extension
38.	600	SF	237310	314-4.3.7	Painted Pavement Markings	\$	\$
39.	400	LF	237310	314-4.3.7	Painted Curb Markings	\$	\$
40.	10,100	LF	237310	314-4.4.6	Thermoplastic Traffic Stripes	\$	\$
41.	725	SF	237310	314-4.4.6	Thermoplastic Pavement Markings	\$	\$
42.	240	EA	237310	314-5.6	Pavement Markers (Retroreflective and Non-retroreflective)	\$	\$
43.	2	EA	237110	701-13.8.4	Storm Water Treatment Basins	\$	\$
44.	1	LS	541330	701-13.8.4	Water Pollution Control Program Development	\$	\$
45.	1	LS	237990	701-13.8.4	Water Pollution Control Program Implementation	\$	\$
46.	1	LS	541330	701-13.8.4	Permit Fee	\$	\$
WATER GROUP JOB 960							
47.	1	LS	524126	2-4.1	Bonds (Payment and Performance)	\$	\$
48.	1	EA	541214	3-3.2.2.1	Certified Payroll	\$	\$
49.	1	LS	238990	7-9.1.1	Video Recording of Pre-existing Conditions	\$	\$
50.	1	LS	237110	9-3.4.1	Mobilization	\$	\$
51.	1	AL		9-3.5	Field Orders - Type II	\$	\$15,000.00
52.	1,000	SF	237310	302-5.2.1	Pavement Restoration Adjacent to Trench	\$	\$
53.	3	EA	237310	303-5.10.2	Curb Ramp Type A with Stainless Steel Detectable Warning Tiles	\$	\$
54.	1	LS	237110	306-1.1.6	Trench Shoring	\$	\$
55.	50	CY	237110	306-1.2.1.1	Additional Bedding	\$	\$
56.	45	TON	237310	306-1.5.1	Temporary Resurfacing	\$	\$
57.	100	TON	237110	306-1.6	Imported Backfill	\$	\$
58.	41	LF	237110	306-1.6	12-Inch Water Main	\$	\$

BIDDING DOCUMENTS

Item	Quantity	Unit	NAICS	Payment Reference	Description	Unit Price	Extension	
59.	1,141	LF	237110	306-1.6	16-Inch Water Main	\$	\$	
60.	9	CY	237110	306-1.6	Thrust Anchor	\$	\$	
61.	1	EA	237110	306-1.6	4-Inch Fire Service Connection & Assembly	\$	\$	
62.	2	EA	237110	306-1.6	6-Inch Fire Hydrant Assembly & Marker	\$	\$	
63.	4	EA	237110	306-1.6	16-Inch Butterfly Valve Class 250B	\$	\$	
64.	2	EA	237110	306-1.6	12-Inch Gate Valve	\$	\$	
65.	15	EA	237110	306-14.1	1-Inch Water Service	\$	\$	
66.	2	EA	237110	306-14.1	2-Inch Copper Water Service	\$	\$	
67.	3	EA	237110	306-5.3	Remove and Cap Abandoned Water Meter Box	\$	\$	
68.	2,400	LF	237110	600-1.2.1.3	High-lining Removed by Contractor	\$	\$	
69.	24	EA	237110	600-1.2.1.3	Water Service Transfer from Highline	\$	\$	
70.	1	LS	237110	600-1.3.1.5	Contractor Furnished Materials for City Forces Connection and Cut-in Work for Mains 16-inch and Larger	\$	\$	
71.	250	SF	237110	600-1.3.1.5	Pavement Restoration for City Forces Final Connection	\$	\$	
72.	41	LF	237110	708-6	Handling and Disposal of Non-friable Asbestos Material	\$	\$	
ESTIMATED TOTAL BASE BID:							\$	\$
ALTERNATE A								
1.	-2,400	LF	237110	600-1.2.1.3	High-lining Removed by the Contractor (Base Bid Item 68)	\$	\$	
2.	1	LS	237110	600-1.3.2.10	High-lining by Contractor	\$	\$	
ESTIMATED TOTAL ALTERNATE A:							\$	\$

BIDDING DOCUMENTS

Item	Quantity	Unit	NAICS	Payment Reference	Description	Unit Price	Extension	
ALTERNATE B								
1.	-250	SF	237110	600-1.3.1.5	Pavement Restoration for City Forces Final Connection (Base Bid Item 71)	\$	\$	
2.	1	EA	237110	600-1.3.2.10	8-Inch through 16-Inch Connections to The Existing System by Contractor	\$	\$	
3.	2	EA	237110	600-1.4.9	Cut and Plug of The Existing System by Contractor	\$	\$	
ESTIMATED TOTAL ALTERNATE B:							\$	\$
ESTIMATED TOTAL BASE BID PLUS ALTERNATE A PLUS ALTERNATE B:							\$	\$

TOTAL BID PRICE FOR BID (Items 1 through 72 Plus Alternate A, item 1 through 2 Plus Alternate B, item 1 through 3, inclusive) amount written in words:

The Bid shall contain an acknowledgment of receipt of all addenda, the numbers of which shall be filled in on the Bid form. If an addendum or addenda has been issued by the City and not noted as being received by the Bidder, this proposal shall be rejected as being **non-responsive**. The following addenda have been received and are acknowledged in this bid: ADDENDUM "A" & ADDENDUM "B" & ADDENDUM "C" & ADDENDUM "D"

The names of all persons interested in the foregoing proposal as principals are as follows:

GUS ASSI HANI ASSI
PRESIDENT SECRETARY OF CORPORATION

IMPORTANT NOTICE: If Bidder or other interested person is a corporation, state secretary, treasurer, and manager thereof; if a co-partnership, state true name of firm, also names of all individual co-partners composing firm; if Bidder or other interested person is an individual, state first and last names in full.

BIDDING DOCUMENTS

HANI ASSI

Bidder: **TRI-GROUP
CONSTRUCTION AND
DEVELOPMENT, INC.**

Title: **SECRETARY OF CORPORATION**

Business Address: **9580 BLACK MOUNTAIN ROAD SUITE "L" SAN DIEGO CA 92126**

Place of Business: **CITY OF SAN DIEGO**

Place of Residence: **CITY OF SAN DIEGO**

Signature: 

NOTES:

- A. The City shall determine the low Bid based on the Base Bid Plus Alternates A and B.
- B. After the low Bid has been determined, the City may award the Contract for the Base Bid alone or if applicable, for the Base Bid plus any combination of alternates selected in the City's sole discretion.
- C. Prices and notations shall be in ink or typewritten. All corrections (which have been initiated by the Bidder using erasures, strike out, line out, or "white-out") shall be typed or written in with ink adjacent thereto, and shall be initialed in ink by the person signing the bid proposal.
- D. Failure to initial all corrections made in the bidding documents shall cause the Bid to be rejected as **non-responsive** and ineligible for further consideration.
- E. Blank spaces must be filled in, using figures. Bidder's failure to submit a price for any Bid item that requires the Bidder to submit a price shall render the Bid **non-responsive** and shall be cause for its rejection.
- F. Unit prices shall be entered for all unit price items. Unit prices shall not exceed two (2) decimal places. If the Unit prices entered exceed two (2) decimal places, the City will only use the first two digits after the decimal points without rounding up or down.
- G. All extensions of the unit prices bid will be subject to verification by the City. In the case of inconsistency or conflict between the product of the Quantity x Unit Price and the Extension, the product shall govern.
- H. In the case of inconsistency or conflict, between the sums of the Extensions with the estimated total Bid, the sum of the Extensions shall govern.
- I. Bids shall not contain any recapitulation of the Work. Conditional Bids will be rejected as being **non-responsive**. Alternative proposals will not be considered unless called for.

BIDDING DOCUMENTS

The names of all persons interested in the foregoing proposal as principals are as follows:

HANI ASSI

GUS ASSI

PRESIDENT

HANI ASSI

SECRETARY OF CORPORATION

IMPORTANT NOTICE: If Bidder or other interested person is a corporation, state secretary, treasurer, and manager thereof; if a co-partnership, state true name of firm, also names of all individual co-partners composing firm; if Bidder or other interested person is an individual, state first and last names in full.

**HRI-GROUP
CONSTRUCTION AND
DEVELOPMENT, INC.**

HANI ASSI

Bidder: _____

SECRETARY OF CORPORATION

Title: _____

Business Address: 9580 BLACK MTN RD SUITE "L" SAN DIEGO CA 92126

Place of Business: CITY OF SAN DIEGO

Place of Residence: CITY OF SAN DIEGO

Signature: 

BIDDING DOCUMENTS

NOTES:

- A. The City shall determine the low Bid based on the Base Bid plus Alternates A and B.
- B. After the low Bid has been determined, the City may award the Contract for the Base Bid alone or if applicable, for the Base Bid plus any combination of alternates selected in the City's sole discretion.
- C. Prices and notations shall be in ink or typewritten. All corrections (which have been initiated by the Bidder using erasures, strike out, line out, or "white-out") shall be typed or written in with ink adjacent thereto, and shall be initialed in ink by the person signing the bid proposal.
- D. Failure to initial all corrections made in the bidding documents shall cause the Bid to be rejected as **non-responsive** and ineligible for further consideration.
- E. Blank spaces must be filled in, using figures. Bidder's failure to submit a price for any Bid item that requires the Bidder to submit a price shall render the Bid **non-responsive** and shall be cause for its rejection.
- F. Unit prices shall be entered for all unit price items. Unit prices shall not exceed two (2) decimal places. If the Unit prices entered exceed two (2) decimal places, the City will only use the first two digits after the decimal points without rounding up or down.
- G. All extensions of the unit prices bid will be subject to verification by the City. In the case of inconsistency or conflict between the product of the Quantity x Unit Price and the Extension, the product shall govern.
- H. In the case of inconsistency or conflict, between the sums of the Extensions with the estimated total Bid, the sum of the Extensions shall govern.
- I. Bids shall not contain anSy recapitulation of the Work. Conditional Bids will be rejected as being **non-responsive**. Alternative proposals will not be considered unless called for.

BIDDING DOCUMENTS

PROPOSAL (BID)

The Bidder agrees to the construction of 25th Street Renaissance Project, for the City of San Diego, in accordance with these contract documents for the prices listed below. The Bidder guarantees the Contract Price for a period of 120 days (90 days for federally funded contracts and contracts valued at \$500,000 or less) from the date of Bid opening to Award of the Contract. The duration of the Contract Price guarantee shall be extended by the number of days required for the City to obtain all items necessary to fulfill all conditions precedent e.g., bond and insurance.

Item	Quantity	Unit	NAICS	Payment Reference	Description	Unit Price	Extension
BASE BID							
25TH STREET RENAISSANCE							
1.	1	LS	524126	2-4.1	Bond (Payment and Performance)	 	\$ 15,000
2.	1	AL	532490	7-10.1.1.1	Reimbursement for Trailers - Type I	 	\$10,000.00
3.	1	LS	237310	7-10.2.7	Traffic Control	 	\$ 40,000
4.	6	EA	238210	9-3.1	Remove and Salvage Existing Traffic Sign	\$ 50	\$ 300
5.	39	EA	238210	9-3.1	Relocate Existing Sign	\$ 185	\$ 7,215
6.	1	LS	238910	9-3.1	Remove and Reinstall Site Furnishings (Including Bus Shelter)	 	\$ 4,000
7.	1	LS	237310	9-3.4.1	Mobilization	 	\$ 40,859
8.	1	AL		9-3.5	Field Orders - Type II	 	\$80,000.00
9.	1	LS	238910	300-1.4	Clearing and Grubbing	 	\$ 155,000
10.	4	EA	238910	300-1.4	Tree Removal	\$ 500	\$ 2,000
11.	1	LS	237310	301-1.7	Adjust Utilities to Grade	 	\$ 4,000

BIDDING DOCUMENTS

Item	Quantity	Unit	NAICS	Payment Reference	Description	Unit Price	Extension
12.	1,405	CY	237310	301-3.3.6	Cement Treated Base	\$ 48	\$ 67,440
13.	44,220	SF	237310	302-1.12	2" Cold Mill Asphalt Pavement	\$ 0.25	\$ 11,055
14.	787	TN	237310	302-5.9	4" Asphalt Concrete Pavement	\$ 105	\$ 82,635
15.	516	TN	237310	302-5.9	2" Asphalt Overlay	\$ 95	\$ 49,020
16.	1,200	SF	237310	302-6.8	Bus Stop Slab	\$ 9	\$ 10,800
17.	16	LF	237110	303-1.12.2	Trench Drain and Cover Grates	\$ 400	\$ 6,400
18.	6	EA	237310	303-5.5.3.2	Decorative Emblems	\$ 18,250	\$ 109,500
19.	10	EA	237310	303-5.9	Relocate Contractor Date Stamps and Impressions	\$ 75	\$ 750
20.	2,260	LF	237310	303-5.9	Curb & Gutter, Type G	\$ 27	\$ 61,020
21.	3,750	SF	237310	303-5.9	Cross Gutter, per SDG-157	\$ 9	\$ 33,750
22.	1,255	SF	237310	303-5.9	Alley Apron, per SDG-120	\$ 9	\$ 11,295
23.	750	SF	237310	303-5.9	Driveway, per SDG-159	\$ 5.50	\$ 4,125
24.	525	SF	237310	303-5.9	Driveway, per SDG-160	\$ 5.50	\$ 2,887.50
25.	90	LF	237310	303-5.9	Median Curb, Type B-1, per SDG-154	\$ 27	\$ 2,430
26.	21,750	SF	237310	303-5.9	PCC Sidewalk	\$ 5.50	\$ 119,625
27.	850	LF	237310	303-5.9	Concrete Band, 12" Wide	\$ 20	\$ 17,000
28.	225	LF	237310	303-5.9	Concrete Band, 24" Wide	\$ 25.50	\$ 5,737.50
29.	3,675	SF	237310	303-9.2	Interlocking Concrete Pavers	\$ 23	\$ 84,525

BIDDING DOCUMENTS

Item	Quantity	Unit	NAICS	Payment Reference	Description	Unit Price	Extension
30.	12	EA	237310	303-5.10.2	Curb Ramp Type A with Stainless Steel Detectable Warning Tiles	\$ 1,750	\$ 21,000
31.	8	EA	237310	303-5.10.2	Curb Ramp Type D with Stainless Steel Detectable Warning Tiles	\$ 1,750	\$ 14,000
32.	2	EA	237310	303-5.10.2	Curb Ramp Case A with Stainless Steel Detectable Warning Tiles	\$ 2,000	\$ 4,000
33.	20	LF	237110	306-1.6	Sidewalk Underdrain, per D-27	\$ 99	\$ 1,980
34.	13	EA	238210	307-2	Relocate Decorative Street Lights	\$ 1,750	\$ 22,750
35.	1	LS	238210	307-2	Traffic Signal Modification	 	\$ 84,000
36.	34	EA	238210	307-2	Install Traffic Sign On Post	\$ 250	\$ 8,500
37.	3,850	LF	237310	314-4.3.7	Painted Traffic Stripes	\$ 0.70	\$ 2,695
38.	600	SF	237310	314-4.3.7	Painted Pavement Markings	\$ 3	\$ 1,800
39.	400	LF	237310	314-4.3.7	Painted Curb Markings	\$ 1.50	\$ 600
40.	10,100	LF	237310	314-4.4.6	Thermoplastic Traffic Stripes	\$ 1	\$ 10,100
41.	725	SF	237310	314-4.4.6	Thermoplastic Pavement Markings	\$ 7	\$ 5,075
42.	240	EA	237310	314-5.6	Pavement Markers (Retroreflective and Non-retroreflective)	\$ 5	\$ 1,200
43.	2	EA	237110	701-13.8.4	Storm Water Treatment Basins	\$ 39,000	\$ 78,000
44.	1	LS	541330	701-13.8.4	Water Pollution Control Program Development	 	\$ 15,000

BIDDING DOCUMENTS

Item	Quantity	Unit	NAICS	Payment Reference	Description	Unit Price	Extension
45.	1	LS	237990	701-13.8.4	Water Pollution Control Program Implementation	 	\$ 9,000
46.	1	AL	541330	701-13.8.4	Permit Fee - Type I	 	\$664.00
WATER GROUP JOB 960							
47.	1	LS	524126	2-4.1	Bonds (Payment and Performance)	 	\$ 5,000
48.	1	EA	541214	3-3.2.2.1	Certified Payroll	\$ 2,000	\$ 2,000
49.	1	LS	238990	7-9.1.1	Video Recording of Pre-existing Conditions	 	\$ 11,000
50.	1	LS	237110	9-3.4.1	Mobilization	 	\$ 10,000
51.	1	AL		9-3.5	Field Orders - Type II	 	\$15,000.00
52.	1,000	SF	237310	302-5.2.1	Pavement Restoration Adjacent to Trench	\$ 6	\$ 6,000
53.	3	EA	237310	303-5.10.2	Curb Ramp Type A with Stainless Steel Detectable Warning Tiles	\$ 2,250	\$ 6,750
54.	1	LS	237110	306-1.1.6	Trench Shoring	 	\$ 4,000
55.	50	CY	237110	306-1.2.1.1	Additional Bedding	\$ 32	\$ 1,600
56.	45	TON	237310	306-1.5.1	Temporary Resurfacing	\$ 175	\$ 7,875
57.	100	TON	237110	306-1.6	Imported Backfill	\$ 15	\$ 1,500
58.	41	LF	237110	306-1.6	12-Inch Water Main	\$ 100	\$ 4,100
59.	1,141	LF	237110	306-1.6	16-Inch Water Main	\$ 135	\$ 154,035
60.	9	CY	237110	306-1.6	Thrust Anchor	\$ 400	\$ 3,600

BIDDING DOCUMENTS

Item	Quantity	Unit	NAICS	Payment Reference	Description	Unit Price	Extension	
61.	1	EA	237110	306-1.6	4-Inch Fire Service Connection & Assembly	\$ 7,400	\$ 7,400	
62.	2	EA	237110	306-1.6	6-Inch Fire Hydrant Assembly & Marker	\$ 6,900	\$ 13,800	
63.	4	EA	237110	306-1.6	16-Inch Butterfly Valve Class 250B	\$ 4,500	\$ 18,000	
64.	2	EA	237110	306-1.6	12-Inch Gate Valve	\$ 6000	\$ 12,000	
65.	40	LF	237110	306-5.3	Large Water Main Abandonment	\$ 65	\$ 2,600	
66.	15	EA	237110	306-14.1	1-Inch Water Service	\$ 2,300	\$ 34,500	
67.	2	EA	237110	306-14.1	2-Inch Copper Water Service	\$ 4,400	\$ 8,800	
68.	3	EA	237110	306-5.3	Remove and Cap Abandoned Water Meter Box	\$ 500	\$ 1,500	
69.	2,400	LF	237110	600-1.2.1.3	High-lining Removed by Contractor	\$ 1	\$ 2,400	
70.	24	EA	237110	600-1.2.1.3	Water Service Transfer from Highline	\$ 351	\$ 8,424	
71.	1	LS	237110	600-1.3.1.5	Contractor Furnished Materials for City Forces Connection and Cut-in Work for Mains 16-Inch and Larger	X	\$ 21,000	
72.	250	SF	237110	600-1.3.1.5	Pavement Restoration for City Forces Final Connection	\$ 15	\$ 3,750	
73.	41	LF	237110	708-6	Handling and Disposal of Non-friable Asbestos Material	\$ 140	\$ 5,740	
ESTIMATED TOTAL BASE BID:							\$ 1,691,107	

BIDDING DOCUMENTS

Item	Quantity	Unit	NAICS	Payment Reference	Description	Unit Price	Extension
ALTERNATE A							
1.	-2,400	LF	237110	600-1.2.1.3	High-lining Removed by Contractor (Base Bid Item 69)	\$ 1	\$ -2,400
2.	1	LS	237110	600-1.3.2.10	High-lining by Contractor	 	\$ 6,500
ESTIMATED TOTAL ALTERNATE A:							\$ 4,100
ALTERNATE B							
1.	-250	SF	237110	600-1.3.1.5	Pavement Restoration for City Forces Final Connection (Base Bid Item 72)	\$ 15	\$ -3,750
2.	1	EA	237110	600-1.3.2.10	8-Inch through 16-Inch Connections to the Existing System by Contractor	\$ 26,500	\$ 26,500
3.	2	EA	237110	600-1.4.9	Cut and Plug of the Existing System by Contractor	\$ 4,500	\$ 9,000
ESTIMATED TOTAL ADDITIVE ALTERNATE B:							\$ 31,750
ESTIMATED TOTAL BID PLUS ALTERNATE A PLUS ALTERNATE B:							\$ 1,726,957

TOTAL BID PRICE FOR BID (Items 1 through 73 Plus Alternate A, item 1 through 2 Plus Alternate B, item 1 through 3, inclusive) amount written in words:

ONE MILLION SEVEN HUNDRED TWENTY SIX THOUSAND NINE HUNDRED FIFTY SEVEN DOLLARS

The Bid shall contain an acknowledgment of receipt of all addenda, the numbers of which shall be filled in on the Bid form. If an addendum or addenda has been issued by the City and not noted as being received by the Bidder, this proposal shall be rejected as being **non-responsive**. The following addenda have been received and are acknowledged in this bid: ADDENDUM "A" ADDENDUM "B"

BIDDING DOCUMENTS

LIST OF SUBCONTRACTORS

In accordance with the requirements provided in the "Subletting and Subcontracting Fair Practices Act", Division 2, Part 1, Chapter 4 of the Public Contract Code, the Bidder shall list below the name and address of each Subcontractor who will perform work, labor, render services or specially fabricates and installs a portion [type] of the work or improvement, in an amount in excess of 0.5% of the Contractor's total Bid. The Bidder shall also list below the portion of the work which will be done by each subcontractor under this Contract. The Contractor shall list only one Subcontractor for each portion of the Work. The **DOLLAR VALUE** of the total Bid to be performed shall be stated for all subcontractors listed. Failure to comply with this requirement shall result in the Bid being rejected as **non-responsive** and ineligible for award. The Bidder's attention is directed to the Special Provisions - General; Paragraph 2-3 Subcontracts, which stipulates the percent of the Work to be performed with the Bidders' own forces. The Bidder shall list all SLBE, ELBE, DBE, DVBE, MBE, WBE, OBE, SDB, WoSB, HUBZone, and SDVOSB Subcontractors that Bidders are seeking recognition towards achieving any mandatory, voluntary, or both subcontracting participation percentages.

NAME, ADDRESS AND TELEPHONE NUMBER OF SUBCONTRACTOR	CONSTRUCTOR OR DESIGNER	TYPE OF WORK	DOLLAR VALUE OF SUBCONTRACT	MBE, WBE, DBE, DVBE, OBE, ELBE, SLBE, SDB, WoSB, HUBZone, OR SDVOSB ^①	WHERE CERTIFIED ^②	CHECK IF JOINT VENTURE PARTNERSHIP
Name: <u>STATEWIDE STRIPES</u> Address: <u>PO BOX 600710</u> City: <u>SAN DIEGO</u> State: <u>CA</u> Zip: <u>92160</u> Phone: <u>619-562-8887</u>	<i>CONSTRUCTOR</i>	<i>STRIPING & SIGNS</i>	<i>\$ 32,431</i> <i>32,551</i> <i>1</i> <i>1/2</i>			
Name: <u>SRM CONTRACTING & PAVING</u> Address: <u>7192 MISSION GORGE RD</u> City: <u>SAN DIEGO</u> State: <u>CA</u> Zip: <u>92120</u> Phone: <u>619-265-0955</u>	<i>CONSTRUCTOR</i>	<i>COLD MILL & ASPHALT</i>	<i>\$</i> <i>128,040.90</i> <i>1</i>	-	-	-
Name: <u>W.E.G. ENGINEERING</u> Address: <u>15780 OLD HWY 80</u> City: <u>EL CAJON</u> State: <u>CA</u> Zip: <u>92021</u> Phone: <u>619-921-7114</u>	<i>CONSTRUCTOR</i>	<i>WATER GROUP JOB</i>	<i>\$</i> <i>269,638.24</i> <i>1</i>	-	-	-

① As appropriate, Bidder shall identify Subcontractor as one of the following and shall include a valid proof of certification (except for OBE, SLBE and ELBE):

Certified Minority Business Enterprise	MBE	Certified Woman Business Enterprise	WBE
Certified Disadvantaged Business Enterprise	DBE	Certified Disabled Veteran Business Enterprise	DVBE
Other Business Enterprise	OBE	Certified Emerging Local Business Enterprise	ELBE
Certified Small Local Business Enterprise	SLBE	Small Disadvantaged Business	SDB
Woman-Owned Small Business	WoSB	HUBZone Business	HUBZone
Service-Disabled Veteran Owned Small Business	SDVOSB		

② As appropriate, Bidder shall indicate if Subcontractor is certified by:

City of San Diego	CITY	State of California Department of Transportation	CALTRANS
California Public Utilities Commission	CPUC	San Diego Regional Minority Supplier Diversity Council	SRMSDC
State of California's Department of General Services	CADoGS	City of Los Angeles	LA
State of California	CA	U.S. Small Business Administration	SBA

The Bidder will not receive any subcontracting participation percentages if the Bidder fails to submit the required proof of certification.

BIDDING DOCUMENTS

LIST OF SUBCONTRACTORS

In accordance with the requirements provided in the "Subletting and Subcontracting Fair Practices Act", Division 2, Part 1, Chapter 4 of the Public Contract Code, the Bidder shall list below the name and address of each Subcontractor who will perform work, labor, render services or specially fabricates and installs a portion [type] of the work or improvement, in an amount in excess of 0.5% of the Contractor's total Bid. The Bidder shall also list below the portion of the work which will be done by each subcontractor under this Contract. The Contractor shall list only one Subcontractor for each portion of the Work. The **DOLLAR VALUE** of the total Bid to be performed shall be stated for all subcontractors listed. Failure to comply with this requirement shall result in the Bid being rejected as **non-responsive** and ineligible for award. The Bidder's attention is directed to the Special Provisions - General; Paragraph 2-3 Subcontracts, which stipulates the percent of the Work to be performed with the Bidders' own forces. The Bidder shall list all SLBE, ELBE, DBE, DVBE, MBE, WBE, OBE, SDB, WoSB, HUBZone, and SDVOSB Subcontractors that Bidders are seeking recognition towards achieving any mandatory, voluntary, or both subcontracting participation percentages.

NAME, ADDRESS AND TELEPHONE NUMBER OF SUBCONTRACTOR	CONSTRUCTOR OR DESIGNER	TYPE OF WORK	DOLLAR VALUE OF SUBCONTRACT	MBE, WBE, DBE, DVBE, OBE, ELBE, SLBE, SDB, WoSB, HUBZone, OR SDVOSB ^①	WHERE CERTIFIED ^②	CHECK IF JOINT VENTURE PARTNERSHIP
Name: <u>PERZY ELECTRIC</u> Address: <u>P.O. BOX 710130</u> City: <u>SAN DIEGO</u> State: <u>CA</u> Zip: <u>92172</u> Phone: <u>619-449-0045</u>	<u>CONSTRUCTOR</u>	<u>STREET LIGHTS & SIGNPL</u>	<u>\$105,500</u>	<u>SLBE</u>	<u>City of SAN DIEGO</u>	<u>-</u>
Name: <u>T.B. PENICK & SONS</u> Address: <u>15435 INNOVATION DR</u> City: <u>SAN DIEGO</u> State: <u>CA</u> Zip: <u>92128</u> Phone: <u>619-538-1380</u>	<u>CONSTRUCTOR</u>	<u>EMBLEMS</u>	<u>\$108,000</u>	<u>-</u>	<u>-</u>	<u>-</u>
Name: _____ Address: _____ City: _____ State: _____ Zip: _____ Phone: _____						

① As appropriate, Bidder shall identify Subcontractor as one of the following and shall include a valid proof of certification (except for OBE, SLBE and ELBE):

Certified Minority Business Enterprise	MBE	Certified Woman Business Enterprise	WBE
Certified Disadvantaged Business Enterprise	DBE	Certified Disabled Veteran Business Enterprise	DVBE
Other Business Enterprise	OBE	Certified Emerging Local Business Enterprise	ELBE
Certified Small Local Business Enterprise	SLBE	Small Disadvantaged Business	SDB
Woman-Owned Small Business	WoSB	HUBZone Business	HUBZone
Service-Disabled Veteran Owned Small Business	SDVOSB		

② As appropriate, Bidder shall indicate if Subcontractor is certified by:

City of San Diego	CITY	State of California Department of Transportation	CALTRANS
California Public Utilities Commission	CPUC	San Diego Regional Minority Supplier Diversity Council	SRMSDC
State of California's Department of General Services	CADoGS	City of Los Angeles	LA
State of California	CA	U.S. Small Business Administration	SBA

The Bidder will not receive any subcontracting participation percentages if the Bidder fails to submit the required proof of certification.

Form Title: LIST OF SUBCONTRACTORS
Form Number: AA35
25th Street Renaissance Project
Federal Aid Project No: RPSTPLE 5004(176)

(Rev. July 2012)

2 of 2

17 | Page

BIDDING DOCUMENTS

NAMED EQUIPMENT/MATERIAL SUPPLIER LIST

The Bidder seeking the recognition of equipment, materials, or supplies obtained from Suppliers towards achieving any mandatory, voluntary, or both subcontracting participation percentages shall list the Supplier(s) on the Named Equipment/Material Supplier List. The Named Equipment/Material Supplier List, at a minimum, shall have the name, locations (City) and the **DOLLAR VALUE** of the Suppliers. The Bidder will be credited up to 60% of the amount to be paid to the Suppliers for such materials and supplies unless vendor manufactures or substantially alters materials and supplies in which case 100% will be credited. The Bidder is to indicate (Yes/No) whether listed firm is a supplier or manufacturer. In calculating the subcontractor participation percentages, vendors/suppliers will receive 60% credit of the listed **DOLLAR VALUE**, whereas manufacturers will receive 100% credit. If no indication provided, listed firm will be credited at 60% of the listed dollar value for purposes of calculating the Subcontractor Participation Percentage, Suppliers will receive 60% credit of the listed **DOLLAR VALUE**, whereas manufacturers will receive 100% credit. If no indication provided, listed firm will be credited at 60% of the listed **DOLLAR VALUE** for purposes of calculating the subcontractor participation percentages.

NAME, ADDRESS AND TELEPHONE NUMBER OF VENDOR/SUPPLIER	MATERIALS OR SUPPLIES	DOLLAR VALUE OF MATERIAL OR SUPPLIES	SUPPLIER (Yes/No)	MANUFACTURE R (Yes/No)	MBE, WBE, DBE, DVBE, OBE, ELBE, SLBE, SDB, WoSB, HUBZone, OR SDVOSB①	WHERE CERTIFIED ②
Name: _____ Address: _____ City: _____ State: _____ Zip: _____ Phone: _____						
Name: _____ Address: _____ City: _____ State: _____ Zip: _____ Phone: _____						
Name: _____ Address: _____ City: _____ State: _____ Zip: _____ Phone: _____						

- ① As appropriate, Bidder shall identify Vendor/Supplier as one of the following and shall include a valid proof of certification (except for OBE, SLBE and ELBE):
- | | | | |
|---|--------|--|---------|
| Certified Minority Business Enterprise | MBE | Certified Woman Business Enterprise | WBE |
| Certified Disadvantaged Business Enterprise | DBE | Certified Disabled Veteran Business Enterprise | DVBE |
| Other Business Enterprise | OBE | Certified Emerging Local Business Enterprise | ELBE |
| Certified Small Local Business Enterprise | SLBE | Small Disadvantaged Business | SDB |
| Woman-Owned Small Business | WoSB | HUBZone Business | HUBZone |
| Service-Disabled Veteran Owned Small Business | SDVOSB | | |
- ② As appropriate, Bidder shall indicate if Vendor/Supplier is certified by:
- | | | | |
|--|--------|--|----------|
| City of San Diego | CITY | State of California Department of Transportation | CALTRANS |
| California Public Utilities Commission | CPUC | San Diego Regional Minority Supplier Diversity Council | SRMSDC |
| State of California's Department of General Services | CADoGS | City of Los Angeles | LA |
| State of California | CA | U.S. Small Business Administration | SBA |

The Bidder will not receive any subcontracting participation percentages if the Bidder fails to submit the required proof of certification.

BIDDING DOCUMENTS

**SUBCONTRACTORS ADDITIVE/DEDUCTIVE ALTERNATE
(USE ONLY WHEN ADDITIVE ALTERNATES ARE REQUIRED)**

Bidder shall list all Subcontractors described in the Bidder's *Base Bid* whose percentage of work will increase or decrease if alternates are selected for award. Bidder shall also list additional Subcontractors not described in the Bidder's *Base Bid* who, as a result of the alternates, will perform work or labor, or render services, or specially fabricate and install a portion [type] of work or improvements in an amount in excess of 0.5%.. The Bidder shall list all SLBE, ELBE, DBE, DVBE, MBE, WBE, OBE, SDB, WoSB, HUBZone, and SDVOSB Subcontractors that Bidders are seeking recognition towards achieving any mandatory, voluntary, or both subcontracting participation percentages.

ADDITIVE/ DEDUCTIVE ALTERNATE	NAME, ADDRESS AND TELEPHONE NUMBER OF SUBCONTRACTOR	CONSTRUCTO R OR DESIGNER	TYPE OF WORK	DOLLAR VALUE OF SUBCONTRACT	MBE, WBE, DBE, DVBE, OBE, ELBE, SLBE, SDB, WoSB, HUBZone, OR SDVOSB [ⓐ]	WHERE CERTIFIED [ⓑ]	CHECK IF JOINT VENTURE PARTNERSHIP
A B	Name: <u>W.E.G ENGINSENG</u> Address: <u>15780 Hwy 80</u> City: <u>EL COTON</u> State: <u>CA</u> Zip: <u>92021</u> Phone: <u>619-521-7114</u>	<i>CONTRACTOR</i>	<i>WATER GROUP JOB</i>	<i>39,445</i>	-	-	-
	Name: _____ Address: _____ City: _____ State: _____ Zip: _____ Phone: _____						
	Name: _____ Address: _____ City: _____ State: _____ Zip: _____ Phone: _____						
	Name: _____ Address: _____ City: _____ State: _____ Zip: _____ Phone: _____						

ⓐ As appropriate, Bidder shall identify Subcontractor as one of the following and shall include a valid proof of certification (except for OBE, SLBE and ELBE):

Certified Minority Business Enterprise	MBE	Certified Woman Business Enterprise	WBE
Certified Disadvantaged Business Enterprise	DBE	Certified Disabled Veteran Business Enterprise	DVBE
Other Business Enterprise	OBE	Certified Emerging Local Business Enterprise	ELBE
Certified Small Local Business Enterprise	SLBE	Small Disadvantaged Business	SDB
Woman-Owned Small Business	WoSB	HUBZone Business	HUBZone
Service-Disabled Veteran Owned Small Business	SDVOSB		

ⓑ As appropriate, Bidder shall indicate if Subcontractor is certified by:

City of San Diego	CITY	State of California Department of Transportation	CALTRANS
California Public Utilities Commission	CPUC	San Diego Regional Minority Supplier Diversity Council	SRMSDC
State of California's Department of General Services	CADoGS	City of Los Angeles	LA
State of California	CA	U.S. Small Business Administration	SBA

The Bidder will not receive any subcontracting participations percentages if the Bidder fails to submit the required proof of certification.

Form Title: SUBCONTRACTORS ADDITIVE/DEDUCTIVE ALTERNATES

(Rev. July 2012)

Form Number: AA45

25th Street Renaissance Project

19 | Page

Federal Aid Project No: RPSTPLE 5004(176)