

City of San Diego

CONTRACTOR'S NAME: _____
ADDRESS: _____
TELEPHONE NO.: _____ FAX NO.: _____
CITY CONTACT: DAMIAN SINGLETON, Contract Specialist, Email: dsingleton@sandiego.gov
Phone No. (619) 533-3482, Fax No. (619) 533-3633
L SCHULTZ / A REYES / LS



CONTRACT DOCUMENTS

FOR

KELTON ROAD SIDEWALK IMPROVEMENTS

VOLUME 1 OF 2

BID NO.:	<u>L-13-5607-DBB-1-A</u>
SAP NO. (WBS/IO/CC):	<u>S-10154</u>
CLIENT DEPARTMENT:	<u>2112</u>
COUNCIL DISTRICT:	<u>4</u>
PROJECT TYPE:	<u>IK</u>

THIS CONTRACT IS SUBJECT TO THE FOLLOWING:

- THE CITY'S SUBCONTRACTING PARTICIPATION REQUIREMENTS FOR SLBE PROGRAM.
- COMPETITION RESTRICTED TO: ELBE

BID DUE DATE:

**1:30 PM
MAY 8, 2013
CITY OF SAN DIEGO
PUBLIC WORKS DEPARTMENT
1010 SECOND AVENUE, SUITE 1400, MS 614C
SAN DIEGO, CA 92101**

ENGINEER OF WORK

The engineering Specifications and Special Provisions contained herein have been prepared by or under the direction of the following Registered Engineer:

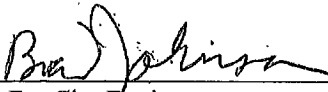
For City Engineer

3/28/13
Date

Seal:



TABLE OF CONTENTS

1. NOTICE INVITING BIDS	4-16
2. CONTRACT FORMS AGREEMENT	17-19
3. CONTRACT/AGREEMENTS ATTACHMENTS	20
1. Performance Bond and Labor and Materialmen’s Bond	21-22
2. Drug-Free Workplace	23
3. American with Disabilities Act (ADA) Compliance Certification	24
4. Contractor Standards - Pledge of Compliance Certificate.....	25
5. Affidavit of Disposal Certificate	26
6. Materials and Workmanship Compliance	27
7. Notice of Materials to Be Used	28
4. SUPPLEMENTARY SPECIAL PROVISIONS	29-40
5. SUPPLEMENTARY SPECIAL PROVISIONS – APPENDICES.....	41
A. Notice of Exemption.....	42-43
B. Fire Hydrant Meter Program	44-58
C. Sample City Invoice	59-60
D. Location Map.....	61-62
E. Caltrans Guardrail Standards.....	63-66
F. Adjacent Projects.....	67-68

CITY OF SAN DIEGO, CALIFORNIA

NOTICE INVITING BIDS

1. **LIMITED COMPETITION:** This contract may only be bid by the Contractors on the City's approved SLBE-ELBE Construction Contractors List. For information regarding the SLBE-ELBE Construction Program and registration visit the City's web site: <http://www.sandiego.gov>.
2. **RECEIPT AND OPENING OF BIDS:** Bids will be received at the Public Works Contracting Group at the location, time, and date shown on the cover of these specifications for performing work on **KELTON ROAD SIDEWALK IMPROVEMENTS** (Project).
3. **DESCRIPTION OF WORK:** The Work involves furnishing all labor, materials, equipment, services, and other incidental works and appurtenances for the construction of the Project as described below:

This project will install new popout sidewalks and guardrail on Kelton Road close to Zircon Street and west of Henry Johnson Elementary School. These improvements include lighted crosswalk, new street markings/stripping, guardrail, sidewalk modifications, and curb ramp installations.

3.1. The Work shall be performed in accordance with:

3.1.1. This Notice Inviting Bids and Plans numbered **36487-1-D** through **36487-5-D**, inclusive.

4. **EQUAL OPPORTUNITY**

4.1. To The WHITEBOOK, Chapter 10, Sections D and E, DELETE in their entirety and SUBSTITUTE with the following:

D. CITY'S EQUAL OPPORTUNITY COMMITMENT.

1. Nondiscrimination in Contracting Ordinance.

1. The Contractor, Subcontractors and Suppliers shall comply with requirements of the City's Nondiscrimination in Contracting Ordinance, San Diego Municipal Code §§22.3501 through 22.3517.

The Contractor shall not discriminate on the basis of race, gender, religion, national origin, ethnicity, sexual orientation, age, or disability in the solicitation, selection, hiring, or treatment of subcontractors, vendors, or suppliers. The Contractor shall provide equal opportunity for subcontractors to participate in subcontracting opportunities. The Contractor understands and agrees that violation of this clause shall be considered a material breach of the contract and may result in contract termination, debarment, or other sanctions.

The Contractor shall include the foregoing clause in all contracts between the Contractor and Subcontractors and Suppliers.

2. Disclosure of Discrimination Complaints. As part of its Bid or Proposal, the Bidder shall provide to the City a list of all instances within the past 10 years where a complaint was filed or pending against Bidder in a legal or administrative proceeding alleging that Bidder discriminated against its employees, subcontractors, vendors, or suppliers, and a description of the status or resolution of that complaint, including any remedial action taken.
3. Upon the City's request, the Contractor agrees to provide to the City, within 60 days, a truthful and complete list of the names of all Subcontractors and Suppliers that the Contractor has used in the past 5 years on any of its contracts that were undertaken within San Diego County, including the total dollar amount paid by the Contractor for each subcontract or supply contract.
4. The Contractor further agrees to fully cooperate in any investigation conducted by the City pursuant to the City's Nondiscrimination in Contracting Ordinance, Municipal Code §§22.3501 through 22.3517. The Contractor understands and agrees that violation of this clause shall be considered a material breach of the Contract and may result in remedies being ordered against the Contractor up to and including contract termination, debarment and other sanctions for violation of the provisions of the Nondiscrimination in Contracting Ordinance. The Contractor further understands and agrees that the procedures, remedies and sanctions provided for in the Nondiscrimination in Contracting Ordinance apply only to violations of the Ordinance.

E. EQUAL EMPLOYMENT OPPORTUNITY OUTREACH PROGRAM.

1. The Contractor, Subcontractors and Suppliers shall comply with the City's Equal Employment Opportunity Outreach Program, San Diego Municipal Code §§22.2701 through 22.2707.

The Contractor shall not discriminate against any employee or applicant for employment on any basis prohibited by law. Contractor shall provide equal opportunity in all employment practices. Prime Contractor shall ensure their subcontractors comply with this program. Nothing in this section shall be interpreted to hold a prime contractor liable for any discriminatory practice of its subcontractors.

The Contractor shall include the foregoing clause in all contracts between the Contractor and Subcontractors and Suppliers.

2. If the Contract is competitively solicited, the selected Bidder shall submit a Work Force Report (Form BB05), within 10 Working Days after receipt by the Bidder of Contract forms to the City for approval as specified in the Notice of Intent to Award letter from the City.

3. If a Work Force Report is submitted, and the City determines there are under-representations when compared to County Labor Force Availability data, the selected Bidder shall submit an Equal Employment Opportunity Plan.
4. If the selected Bidder submits an Equal Employment Opportunity Plan, it shall include the following assurances:
 1. The Contractor shall maintain a working environment free of discrimination, harassment, intimidation and coercion at all sites and in all facilities at which the Contractor's employees are assigned to work.
 2. The Contractor reviews its EEO Policy, at least annually, with all on-site supervisors involved in employment decisions.
 3. The Contractor disseminates and reviews its EEO Policy with all employees at least once a year, posts the policy statement and EEO posters on all company bulletin boards and job sites, and documents every dissemination, review and posting with a written record to identify the time, place, employees present, subject matter, and disposition of meetings.
 4. The Contractor reviews, at least annually, all supervisors' adherence to and performance under the EEO Policy and maintains written documentation of these reviews.
 5. The Contractor discusses its EEO Policy Statement with subcontractors with whom it anticipates doing business, includes the EEO Policy Statement in its subcontracts, and provides such documentation to the City upon request.
 6. The Contractor documents and maintains a record of all bid solicitations and outreach efforts to and from subcontractors, contractor associations and other business associations.
 7. The Contractor disseminates its EEO Policy externally through various media, including the media of people of color and women, in advertisements to recruit, maintains files documenting these efforts, and provides copies of these advertisements to the City upon request.
 8. The Contractor disseminates its EEO Policy to union and community organizations.
 9. The Contractor provides immediate written notification to the City when any union referral process has impeded the Contractor's efforts to maintain its EEO Policy.
 10. The Contractor maintains a current list of recruitment sources, including those outreaching to people of color and women, and

provides written notification of employment opportunities to these recruitment sources with a record of the organizations' responses.

11. The Contractor maintains a current file of names, addresses and phone numbers of each walk-in applicant, including people of color and women, and referrals from unions, recruitment sources, or community organizations with a description of the employment action taken.
12. The Contractor encourages all present employees, including people of color and women employees, to recruit others.
13. The Contractor maintains all employment selection process information with records of all tests and other selection criteria.
14. The Contractor develops and maintains documentation for on-the-job training opportunities, participates in training programs, or both for all of its employees, including people of color and women, and establishes apprenticeship, trainee, and upgrade programs relevant to the Contractor's employment needs.
15. The Contractor conducts, at least annually, an inventory and evaluation of all employees for promotional opportunities and encourages all employees to seek and prepare appropriately for such opportunities.
16. The Contractor ensures the company's working environment and activities are non-segregated except for providing separate or single-user toilets and necessary changing facilities to assure privacy between the sexes.

5. SUBCONTRACTING PARTICIPATION PERCENTAGES.

- 5.1. The City has incorporated voluntary subcontractor participation percentage to enhance competition and maximize subcontracting opportunities as follows.
- 5.2. The following voluntary subcontractor participation percentage for DBE, DVBE, WBE, MBE, SLBE, and ELBE certified Subcontractors shall apply to this contract:

**Total voluntary subcontractor participation percentage for this project is
14.4%.**

6. PRE-BID MEETING:

- 6.1. There will be a Pre-Bid Meeting to discuss the scope of the Project, bidding requirements, pre-qualification process, and Equal Opportunity Contracting Program requirements and reporting procedures in the **Public Works Contracting Group, Conference Room at 1010 Second Avenue, Suite 1400, San Diego, CA 92101 at 10:00 A.M., on APRIL 16th, 2013.**
- 6.2. All potential bidders are encouraged to attend.

6.3. To request a copy of the agenda on an alternative format, or to request a sign language or oral interpreter for this meeting, call the Public Works Contracting Group at (619) 533-3450 at least 5 Working Days prior to the Pre-Bid Meeting to ensure availability.

7. **CONTRACTOR REGISTRATION AND ELECTRONIC REPORTING SYSTEM:**

7.1. **Prior** to the Award of the Contract or each Task Order, you and your Subcontractors and Suppliers **must** register with Prism®, the City's web-based contract compliance portal at:

<https://pro.prismcompliance.com/default.aspx>.

7.2. The City may not award the contract until registration of all subcontractors and suppliers is complete. In the event this requirement is not met within the time frame specified in the Notice of Intent to Award letter, the City reserves the right to rescind the Notice of Award / Intent to Award and to make the award to the next responsive and responsible bidder / proposer.

8. **CONSTRUCTION COST:** The City's estimated construction cost for this contract is **\$126,000.00**.

9. **LOCATION OF WORK:** The location of the Work is as follows:

Kelton Road between Bethune Court and Zircon Street

10. **CONTRACT TIME:** The Contract Time for completion of the Work shall be **33 Working Days**.

11. **CONTRACTOR'S LICENSE CLASSIFICATION:** In accordance with the provisions of California Law, the Contractor shall possess valid appropriate license(s) at the time that the Bid is submitted. Failure to possess the specified license(s) shall render the Bid as **non-responsive** and shall act as a bar to award of the Contract to any Bidder not possessing required license(s) at the time of Bid.

11.1. The City has determined the following licensing classification for this contract:

- **CLASS A**

12. **JOINT VENTURE CONTRACTORS.** Provide a copy of the Joint Venture agreement and the Joint Venture license to the City within 10 Working Days after receiving the Contract forms. See 2-1.1.2, "Joint Venture Contractors" in The WHITEBOOK for details.

13. **WAGE RATES:** Prevailing wages are not applicable to this contract.

14. **INSURANCE REQUIREMENTS:**

14.1. All certificates of insurance and endorsements required by the contract are to be provided upon issuance of the City's Notice of Intent to Award letter.

14.2. Refer to sections 7-3, “LIABILITY INSURANCE”, and 7-4, “WORKERS’ COMPENSATION INSURANCE” of the Supplementary Special Provisions (SSP) for the insurance requirements which must be met.

15. PREQUALIFICATION OF CONTRACTORS:

15.1. Contractors submitting Bid must be pre-qualified for the total amount proposed, inclusive of all alternate items prior to the date of submittal. Bids from contractors who have not been pre-qualified as applicable and Bids that exceed the maximum dollar amount at which contractors are pre-qualified will be deemed **non-responsive** and ineligible for award. Complete information and prequalification questionnaires are available at:

<http://www.sandiego.gov/cip/bidopps/prequalification.shtml>

15.2. The completed questionnaire, financial statement, and bond letter or a copy of the contractor’s SLBE-ELBE certification and bond letter, must be submitted no later than 2 weeks prior to the bid opening to the Public Works Department - Engineering & Capital Project, Prequalification Program, 1010 Second Avenue, Suite 1200, San Diego, CA 92101. For additional information or the answer to questions about the prequalification program, contact David Stucky at 619-533-3474 or dstucky@sandiego.gov.

16. **REFERENCE STANDARDS:** Except as otherwise noted or specified, the Work shall be completed in accordance with the following standards:

Title	Edition	Document Number
Standard Specifications for Public Works Construction (“The GREENBOOK”)	2012	PITS070112-01
City of San Diego Standard Specifications for Public Works Construction (“The WHITEBOOK”)*	2012	PITS070112-02
City of San Diego Standard Drawings*	2012	PITS070112-03
Caltrans Standard Specifications	2010	PITS070112-04
Caltrans Standard Plans	2010	PITS070112-05
California MUTCD	2012	PITS070112-06
City Standard Drawings - Updates Approved For Use (when specified)*	Varies	Varies
Standard Federal Equal Employment Opportunity Construction Contract Specifications and the Equal Opportunity Clause Dated 09-11-84	1984	769023
NOTE: Available online under Engineering Documents and References at: http://www.sandiego.gov/publicworks/edocref/index.shtml .		

17. **CITY’S RESPONSES AND ADDENDA:** The City at its option, may respond to any or all questions submitted in writing, via letter, or FAX in the form of an addendum. No oral comment shall be of any force or effect with respect to this solicitation. The changes to the

Contract Documents through addendum are made effective as though originally issued with the Bid. The Bidders shall acknowledge the receipt of Addenda on the form provided for this purpose in the Bid.

- 18. CITY'S RIGHTS RESERVED:** The City reserves the right to cancel the Notice Inviting Bids at any time, and further reserves the right to reject submitted Bids, without giving any reason for such action, at its sole discretion and without liability. Costs incurred by the Bidder(s) as a result of preparing Bids under the Notice Inviting Bids shall be the sole responsibility of each bidder. The Notice Inviting Bids creates or imposes no obligation upon the City to enter a contract.
- 19. CONTRACT PRICING FORMAT:** This solicitation is for a Lump Sum contract with Unit Price provisions as set forth in the Bid Proposal Form(s), Volume 2.
- 20. SUBMITTAL OF "OR EQUAL" ITEMS:** See Section 4-1.6, "Trade Names or Equals" in The WHITEBOOK and as amended in the SSP.
- 21. AWARD PROCESS:**
 - 21.1.** The Award of this contract is contingent upon the Contractor's compliance with all conditions precedent to Award.
 - 21.2.** Upon acceptance of a Bid, the City will prepare contract documents for execution within approximately 21 days of the date of the Bid opening and award the Contract approximately within 7 days of receipt of properly executed Contract, bonds, and insurance documents.
 - 21.3.** This contract will be deemed executed, and effective, only upon the signing of the Contract by the Mayor or designee of the City.
- 22. SUBCONTRACT LIMITATIONS:** The Bidder's attention is directed to Standard Specifications for Public Works Construction, Section 2-3, "SUBCONTRACTS" in The WHITEBOOK and as amended in the SSP which requires the Contractor to self perform the amount therein stipulated. Failure to comply with these requirements may render the Bid **non-responsive** and ineligible for award.
- 23. AVAILABILITY OF PLANS AND SPECIFICATIONS:** Contract Documents may be obtained by visiting the City's website: <http://www.sandiego.gov/cip/>. Plans and Specifications for this contract are also available for review in the office of the City Clerk or Public Works Contracting Group.
- 24. QUESTIONS:**
 - 24.1.** The Director (or designee), of the Public Works Department is the officer responsible for opening, examining, and evaluating the competitive Bids submitted to the City for the acquisition, construction and completion of any public improvement except when otherwise set forth in these documents. All questions related to this procurement action shall be addressed to the Public Works Contracting Group, Attention Contract Specialist, 1010 Second Avenue, Suite 1400, San Diego, California, 92101, and Telephone No. (619) 533-3450.

- 24.2. Questions received less than 14 days prior to the date for opening of Bids may not be answered.
- 24.3. Interpretations or clarifications considered necessary by the City in response to such questions will be issued by Addenda which will be uploaded to the City's online bidding service.
- 24.4. Only questions answered by formal written addenda will be binding. Oral and other interpretations or clarifications will be without legal effect. It is the Bidder's responsibility to become informed of any Addenda that have been issued and to include all such information in its Bid.
25. **ELIGIBLE BIDDERS:** No person, firm, or corporation shall be allowed to make, file, or be interested in **more** than one (1) Bid for the same work unless alternate Bids are called for. A person, firm or corporation who has submitted a sub-proposal to a Bidder, or who has quoted prices on materials to a Bidder, is not hereby disqualified from submitting a sub-proposal or quoting prices to other Bidders or from submitting a Bid in its own behalf. Any Bidder who submits more than one bid will result in the rejection of all bids submitted.
26. **SAN DIEGO BUSINESS TAX CERTIFICATE:** The Contractor and Subcontractors, not already having a City of San Diego Business Tax Certificate for the work contemplated shall secure the appropriate certificate from the City Treasurer, Civic Center Plaza, first floor and submit to the Contract Specialist upon request or as specified in the Contract Documents. Tax Identification numbers for both the Bidder and the listed Subcontractors must be submitted on the City provided forms with the Notice Inviting Bids and Contract forms.
27. **PROPOSAL FORMS:** Bid shall be made only upon the Bidding Documents i.e., Proposal form attached to and forming a part of the specifications. The signature of each person signing shall be in longhand.
- 27.1. Bidder shall complete and submit all pages in the "Bidding Document" Section (see Volume 2) as their Bid per the schedule given under "Required Documents Schedule," (see Volume 1). Bidder is requested to retain for their reference other portions of the Contract Documents that are not required to be submitted with the Bid. The entire specifications for the bid package do not need to be submitted with the bid.
- 27.2. The City may require any Bidder to furnish a statement of experience, financial responsibility, technical ability, equipment, and references.
- 27.3. Bids and certain other forms and documents as specified in the Volume 2 of 2 of the Contract Documents shall be enclosed in a sealed envelope and shall bear the title of the work and name of the Bidder and the appropriate State Contractors License designation which the Bidder holds.
- 27.4. Bids may be withdrawn by the Bidder prior to, but not after, the time fixed for opening of Bids.

28. BIDDERS' GUARANTEE OF GOOD FAITH (BID SECURITY):

- 28.1.** With the exception of the contracts valued \$5,000 or less, JOC and Design-Build contracts, and contracts subject to the Small and Local Business Program of \$250,000 or less e.g., ELBE contracts, each Bidder shall accompany its Bid with either a cashier's check upon some responsible bank, or a check upon such bank properly certified or an approved corporate surety bond payable to the City of San Diego, for an amount of not less than 10% of the aggregate sum of the Bid, which check or bond, and the monies represented thereby shall be held by the City as a guarantee that the Bidder, if awarded the contract, will in good faith enter into such contract and furnish the required final bonds.
- 28.2.** The Bidder agrees that in case of Bidder's refusal or failure to execute this contract and give required final bonds, the money represented by a cashier's or certified check shall remain the property of the City, and if the Bidder shall fail to execute this contract, the Surety agrees that it will pay to the City damages which the City may suffer by reason of such failure, not exceeding the sum of 10% of the amount of the Bid.
- 28.3.** A Bid received without the specified bid security will be rejected as being **non-responsive**.

29. AWARD OF CONTRACT OR REJECTION OF BIDS:

- 29.1.** This contract may be awarded to the lowest responsible and reliable Bidder.
- 29.2.** Bidders shall complete the entire Bid schedule (also referred to as "schedule of prices" or Proposal form). Incomplete price schedules will be rejected as being non-responsive.
- 29.3.** The City reserves the right to reject any or all Bids, and to waive any informality or technicality in Bids received and any requirements of these specifications as to bidding procedure.
- 29.4.** Bidders will not be released on account of their errors of judgment. Bidders may be released only upon receipt by the City from the Bidder within 3 Working Days, excluding Saturdays, Sundays, and state holidays, after the opening of Bids, of written notice which includes proof of honest, credible, clerical error of material nature, free from fraud or fraudulent intent, and of evidence that reasonable care was observed in the preparation of the Bid.
- 29.5.** A non-selected Bidder may protest award of the Contract to the selected Bidder by submitting a written "Notice of Intent to Protest" including supporting documentation which shall be received by Public Works Contracting Group no later than 10 days after the City's announcement of the selected Bidder or no later than 10 days from the date that the City issues notice of designation of a Bidder as non-responsive in accordance with San Diego Municipal Code Chapter 2, § 22.3029, "Protests of Contract Award."

- 29.6. The City of San Diego will not discriminate with regard to race, religious creed, color, national origin, ancestry, physical handicap, marital status, sex or age, in the award of contracts.
- 29.7. Each Bid package properly executed as required by these specifications shall constitute a firm offer, which may be accepted by the City within the time specified in the Proposal.
- 29.8. The City reserves the right to evaluate all Bids and determine the lowest Bidder on the basis of any proposed alternates, additive items or options, at its discretion that will be disclosed in the Volume 2 of 2.

30. BID RESULTS:

- 30.1. The Bid opening by the City shall constitute the public announcement of the Apparent Low Bidder. In the event that the Apparent Low Bidder is subsequently deemed non-responsive or non-responsible, a public announcement will be posted in the City's web page: <http://www.sandiego.gov/cip/index.shtml>, with the name of the newly designated Apparent Low Bidder.
- 30.2. To obtain Bid results, either attend Bid opening, review the results on the City's web site, or provide a self-addressed, stamped envelope, referencing Bid number, and Bid tabulation will be mailed to you upon verification of extensions. Bid results cannot be given over the telephone.

31. THE CONTRACT:

- 31.1. The Bidder to whom award is made shall execute a written contract with the City of San Diego and furnish good and approved bonds and insurance certificates specified by the City within 14 days after receipt by Bidder of a form of contract for execution unless an extension of time is granted to the Bidder in writing.
- 31.2. If the Bidder takes longer than 14 days to fulfill these requirements, then the additional time taken shall be added to the Bid guarantee. The Contract shall be made in the form adopted by the City, which includes the provision that no claim or suit whatsoever shall be made or brought by Contractor against any officer, agent, or employee of the City for or on account of anything done or omitted to be done in connection with this contract, nor shall any such officer, agent, or employee be liable hereunder.
- 31.3. If the Bidder to whom the award is made fails to enter into the contract as herein provided, the award may be annulled and the Bidder's Guarantee of Good Faith will be subject to forfeiture. An award may be made to the next lowest responsible and reliable Bidder who shall fulfill every stipulation embraced herein as if it were the party to whom the first award was made.
- 31.4. Pursuant to the San Diego City Charter section 94, the City may only award a public works contract to the lowest responsible and reliable Bidder. The City will require the Apparent Low Bidder to (i) submit information to determine the Bidder's responsibility and reliability, (ii) execute the Contract in form provided by the City, and (iii) furnish good and approved bonds and insurance certificates specified by the

City within 14 Days, unless otherwise approved by the City, in writing after the Bidder receives notification from the City, designating the Bidder as the Apparent Low Bidder and formally requesting the above mentioned items.

- 31.5.** The award of the Contract is contingent upon the satisfactory completion of the above mentioned items and becomes effective upon the signing of the Contract by the Mayor or designee. If the Apparent Low Bidder does not execute the Contract or submit required documents and information, the City may award the Contract to the next lowest responsible and reliable Bidder who shall fulfill every condition precedent to award. A corporation designated as the Apparent Low Bidder shall furnish evidence of its corporate existence and evidence that the officer signing the Contract and bond for the corporation is duly authorized to do so.
- 32. EXAMINATION OF PLANS, SPECIFICATIONS, AND SITE OF WORK:** The Bidder shall examine carefully the Project Site, the Plans and Specifications, other materials as described in the Special Provisions, Section 2-7, and the proposal forms (e.g., Bidding Documents). The submission of a Bid shall be conclusive evidence that the Bidder has investigated and is satisfied as to the conditions to be encountered, as to the character, quality, and scope of Work, the quantities of materials to be furnished, and as to the requirements of the Bidding Documents Proposal, Plans, and Specifications.
- 33. CITY STANDARD PROVISIONS.** This contract is subject to the following standard provisions. See The WHITEBOOK for details.
- 33.1.** The City of San Diego Resolution No. R-277952 adopted on May 20, 1991 for a Drug-Free Workplace.
- 33.2.** The City of San Diego Resolution No. R-282153 adopted on June 14, 1993 related to the Americans with Disabilities Act.
- 33.3.** The City of San Diego Municipal Code §22.3004 for Pledge of Compliance.
- 33.4.** The City of San Diego’s Labor Compliance Program and the State of California Labor Code §§1771.5(b) and 1776.
- 33.5.** Sections 1777.5, 1777.6, and 1777.7 of the State of California Labor Code concerning the employment of apprentices by contractors and subcontractors performing public works contracts.
- 33.6.** The City’s Equal Benefits Ordinance (EBO), Chapter 2, Article 2, Division 43 of The San Diego Municipal Code (SDMC).
- 33.7.** The City’s Information Security Policy (ISP) as defined in the City’s Administrative Regulation 90.63.
- 34. PRE-AWARD ACTIVITIES:**
- 34.1.** The selected contractor by the City to execute a contract for this Work shall provide the information required within the time specified in “Required Documents,” of this bid package. Failure to provide the information within the time specified may result in the Bid being rejected as **non-responsive**.

34.2. If the Bid is rejected as non-responsive, the selected contractor by the City to execute a contract for this Work shall forfeit the required Bid. The decision that the selected contractor by the City to execute a contract for this Work is non-responsive for failure to provide the information required within the time specified shall be at the sole discretion of the City.

35. REQUIRED DOCUMENT SCHEDULE:

35.1. The Bidder’s attention is directed to the City’s Municipal Code §22.0807(e), (3)-(5) for important information regarding grounds for debarment for failure to submit required documentation.

35.2. The specified Equal Opportunity Contracting Program (EOCP) forms are available for download from the City’s web site at:

<http://www.sandiego.gov/eoc/forms/index.shtml>

ITEM	WHEN DUE	FROM	DOCUMENT TO BE SUBMITTED
1.	BID SUBMITTAL DATE/TIME	ALL BIDDERS	Bid
2.	BID SUBMITTAL DATE/TIME	ALL BIDDERS	Non-collusion Affidavit to be Executed By Bidder and Submitted with Bid under 23 USC 112 and PCC 7106
3.	BID SUBMITTAL DATE/TIME	ALL BIDDERS	Contractors Certification of Pending Actions
4.	BID SUBMITTAL DATE/TIME	ALL BIDDERS	Equal Benefits Ordinance Certification of Compliance
5.	BID SUBMITTAL DATE/TIME	ALL BIDDERS	Form AA35 - List of Subcontractors
6.	BID SUBMITTAL DATE/TIME	ALL BIDDERS	Form AA40 - Named Equipment/Material Supplier List
7.	WITHIN 10 WORKING DAYS AFTER RECEIPT BY BIDDER OF CONTRACT FORMS	APPARENT LOW BIDDER	Names of the principal individual owners of the Apparent Low Bidder
8.	WITHIN 10 WORKING DAYS AFTER RECEIPT BY BIDDER OF CONTRACT FORMS	APPARENT LOW BIDDER	If the Contractor is a Joint Venture: <ul style="list-style-type: none"> • Joint Venture Agreement • Joint Venture License
9.	WITHIN 10 WORKING DAYS AFTER RECEIPT BY BIDDER OF CONTRACT FORMS	APPARENT LOW BIDDER	Form BB05 - Work Force Report

ITEM	WHEN DUE	FROM	DOCUMENT TO BE SUBMITTED
10.	WITHIN 10 WORKING DAYS AFTER RECEIPT BY BIDDER OF CONTRACT FORMS	APPARENT LOW BIDDER	Contract Forms - Agreement
11.	WITHIN 10 WORKING DAYS AFTER RECEIPT BY BIDDER OF CONTRACT FORMS	APPARENT LOW BIDDER	Contract Forms - Payment and Performance Bond
12.	WITHIN 10 WORKING DAYS AFTER RECEIPT BY BIDDER OF CONTRACT FORMS	APPARENT LOW BIDDER	Certificates of Insurance and Endorsements
13.	WITHIN 10 WORKING DAYS AFTER RECEIPT BY BIDDER OF CONTRACT FORMS	APPARENT LOW BIDDER	Contractor Certification - Drug-Free Workplace
14.	WITHIN 10 WORKING DAYS AFTER RECEIPT BY BIDDER OF CONTRACT FORMS	APPARENT LOW BIDDER	Contractor Certification - American with Disabilities Act
15.	WITHIN 10 WORKING DAYS AFTER RECEIPT BY BIDDER OF CONTRACT FORMS	APPARENT LOW BIDDER	Contractors Standards - Pledge of Compliance

CONTRACT FORMS
AGREEMENT

CONTRACT FORMS AGREEMENT

CONSTRUCTION CONTRACT

This contract is made and entered into between THE CITY OF SAN DIEGO, a municipal corporation, herein called "City", and HTA ENGINEERING & CONSTRUCTION, INC., herein called "Contractor" for construction of **KELTON ROAD SIDEWALK IMPROVEMENTS**; BidNo. **L-13-5607-DBB-1-A**, in the amount of ONE HUNDRED THIRTEEN THOUSAND EIGHT HUNDRED DOLLARS AND 00/100 (\$113,800.00), which is comprised of the Base Bid.

IN CONSIDERATION of the payments to be made hereunder and the mutual undertakings of the parties hereto, City and Contractor agree as follows:

1. The following are incorporated into this contract as though fully set forth herein:
 - (a) The attached Faithful Performance and Payment Bonds.
 - (b) The attached Proposal included in the Bid documents by the Contractor.
 - (c) Reference Standards listed in the Notice Inviting Bids and the Supplementary Special Provisions (SSP).
 - (d) That certain documents entitled **KELTON ROAD SIDEWALK IMPROVEMENTS**, on file in the office of the Public Works Department as Document No. **S-10154**, as well as all matters referenced therein.
2. The Contractor shall perform and be bound by all the terms and conditions of this contract and in strict conformity therewith shall perform and complete in a good and workmanlike manner **KELTON ROAD SIDEWALK IMPROVEMENTS**, Bid No. **L-13-5607-DBB-1-A**, San Diego, California.
3. For such performances, the City shall pay to Contractor the amounts set forth at the times and in the manner and with such additions or deductions as are provided for in this contract, and the Contractor shall accept such payment in full satisfaction of all claims incident to such performances.
4. No claim or suit whatsoever shall be made or brought by Contractor against any officer, agent, or employee of the City for or on account of anything done or omitted to be done in connection with this contract, nor shall any such officer, agent, or employee be liable hereunder.
5. This contract is effective as of the date that the Mayor or designee signs the agreement.

CONTRACT FORMS (continued)

AGREEMENT

IN WITNESS WHEREOF, this Agreement is signed by the City of San Diego, acting by and through its Mayor or designee, pursuant to Municipal Code §22.3102(d) authorizing such execution.

THE CITY OF SAN DIEGO

APPROVED AS TO FORM AND LEGALITY

Jan I. Goldsmith, City Attorney

By Tony Heinrichs

By Ryan P. Gerrity

Print Name: Tony Heinrichs
Director, Department of Public Works

Print Name: RYAN P GERRITY
Deputy City Attorney

Date: 7/19/13

Date: 7/19/13

CONTRACTOR

By Hatim T. Askar

Print Name: Hatim T. Askar

Title: President

Date: 06/11/13

City of San Diego License No. 82003002063

State Contractor's License No.: 798372

CONTRACT/AGREEMENT
ATTACHMENTS

Premium Is For Contract Term
And Is Subject To Adjustment
Based On Final Contract Price

EXECUTED IN TRIPLICATE
BOND NO. 1000957121
PREMIUM: \$2,707.00

CONTRACT ATTACHMENT PERFORMANCE BOND AND LABOR AND MATERIALMEN'S BOND

FAITHFUL PERFORMANCE BOND AND LABOR AND MATERIALMEN'S BOND:

HTA CONSTRUCTION
HTA ENGINEERING & CONSTRUCTION, INC. DBA: , a corporation, as principal, and
U.S. SPECIALTY INSURANCE COMPANY , a corporation authorized to do
business in the State of California, as Surety, hereby obligate themselves, their successors and
assigns, jointly and severally, to The City of San Diego a municipal corporation in the sum of
ONE HUNDRED THIRTEEN THOUSAND EIGHT HUNDRED DOLLARS AND 00/100
(\$113,800.00) for the faithful performance of the annexed contract, and in the sum of ____
ONE HUNDRED THIRTEEN THOUSAND EIGHT HUNDRED DOLLARS AND 00/100
(\$113,800.00) for the benefit of laborers and materialmen designated below.

Conditions:

If the Principal shall faithfully perform the annexed contract **KELTON ROAD SIDEWALK IMPROVEMENTS**; Bid No. **L-13-5607-DBB-1-A**, San Diego, California then the obligation herein with respect to a faithful performance shall be void; otherwise it shall remain in full force.

If the Principal shall promptly pay all persons, firms and corporations furnishing materials for or performing labor in the execution of this contract, and shall pay all amounts due under the California Unemployment Insurance Act then the obligation herein with respect to laborers and materialmen shall be void; otherwise it shall remain in full force.

The obligation herein with respect to laborers and materialmen shall inure to the benefit of all persons, firms and corporations entitled to file claims under the provisions of Chapter 3 of Division 5 of Title I of the Government Code of the State of California or under the provisions of Section 3082 et seq. of the Civil Code of the State of California.

Changes in the terms of the annexed contract or specifications accompanying same or referred to therein shall not affect the Surety's obligation on this bond, and the Surety hereby waives notice of same.

CONTRACT ATTACHMENT (continued)
PERFORMANCE BOND AND LABOR AND MATERIALMEN'S BOND

The Surety shall pay reasonable attorney's fees should suit be brought to enforce the provisions of this bond.

Dated JUNE 10, 2013

Approved as to Form and Legality

HTA ENGINEERING & CONSTRUCTION, INC.
DBA: HTA CONSTRUCTION
Principal

By Hatim T. Askar

HATIM T. ASKAR, PRESIDENT
Printed Name of Person Signing for Principal

Jan I. Goldsmith, City Attorney

By 
Deputy City Attorney

U.S. SPECIALTY INSURANCE COMPANY
Surety

By 
MARK D. IATAROLA, Attorney-in-fact

Approved:

601 SOUTH FIGUEROA STREET, SUITE 1600
Local Address of Surety

By 
Tony Heinrichs
Director, Department of Public Works

LOS ANGELES, CA 90017
Local Address (City, State) of Surety

310/649-0990
Local Telephone No. of Surety

**Premium Is For Contract Term
And Is Subject To Adjustment
Based On Final Contract Price**

Premium \$ 2,707.00

Bond No. 1000957121

CALIFORNIA ALL-PURPOSE ACKNOWLEDGMENT

STATE OF CALIFORNIA

County of SAN DIEGO }

On 6/10/2013 before me, DEBORAH D. DAVIS, NOTARY PUBLIC,
Date Here Insert Name and Title of the Officer

personally appeared MARK D. IATAROLA
Name(s) of Signer(s)

who proved to me on the basis of satisfactory evidence to be the person(s) whose name(s) is/are subscribed to the within instrument and acknowledged to me that he/she/they executed the same in his/her/their authorized capacity(ies), and that by his/her/their signature(s) on the instrument the person(s), or the entity upon behalf of which the person(s) acted, executed the instrument.

I certify under PENALTY OF PERJURY under the laws of the State of California that the foregoing paragraph is true and correct.

Witness my hand and official seal.

Signature [Handwritten Signature]
Signature of Notary Public



Place Notary Seal Above

OPTIONAL

Though the information below is not required by law, it may prove valuable to persons relying on the document and could prevent fraudulent removal and reattachment of this form to another document.

Description of Attached Document

Title or Type of Document: _____

Document Date: _____ Number of Pages: _____

Signer(s) Other Than Named Above: _____

Capacity(ies) Claimed by Signer(s)

Signer's Name: MARK D. IATAROLA

- Individual
- Corporate Officer — Title(s): _____
- Partner — Limited General
- Attorney in Fact
- Trustee
- Guardian or Conservator
- Other: _____

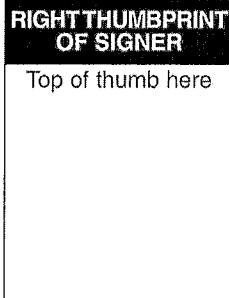

Signer Is Representing:

Signer's Name: _____

- Individual
- Corporate Officer — Title(s): _____
- Partner — Limited General
- Attorney in Fact
- Trustee
- Guardian or Conservator
- Other: _____



Signer Is Representing:

CALIFORNIA ALL-PURPOSE ACKNOWLEDGMENT

STATE OF CALIFORNIA

County of SAN DIEGO }

On 10/11/2015 before me, BEVERLEY J. CROSS, NOTARY PUBLIC,
Date Here Insert Name and Title of the Officer

personally appeared HATIM T. ASKAR
Name(s) of Signer(s)

who proved to me on the basis of satisfactory evidence to be the person(s) whose name(s) is/are subscribed to the within instrument and acknowledged to me that he/she/they executed the same in his/her/their authorized capacity(ies), and that by his/her/their signature(s) on the instrument the person(s), or the entity upon behalf of which the person(s) acted, executed the instrument.

I certify under PENALTY OF PERJURY under the laws of the State of California that the foregoing paragraph is true and correct.

Witness my hand and official seal.

Signature [Handwritten Signature]
Signature of Notary Public

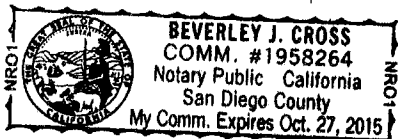

Place Notary Seal Above

OPTIONAL

Though the information below is not required by law, it may prove valuable to persons relying on the document and could prevent fraudulent removal and reattachment of this form to another document.

Description of Attached Document

Title or Type of Document: _____

Document Date: _____ Number of Pages: _____

Signer(s) Other Than Named Above: _____

Capacity(ies) Claimed by Signer(s)

Signer's Name: HATIM T. ASKAR

- Individual
- Corporate Officer — Title(s): PRESIDENT
- Partner — Limited General
- Attorney in Fact
- Trustee
- Guardian or Conservator
- Other: _____

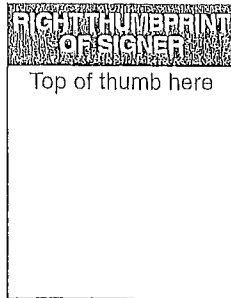

Signer Is Representing: _____

Signer's Name: _____

- Individual
- Corporate Officer — Title(s): _____
- Partner — Limited General
- Attorney in Fact
- Trustee
- Guardian or Conservator
- Other: _____

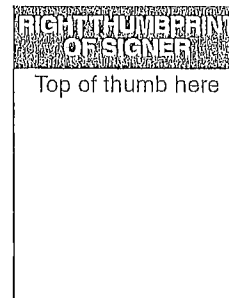

Signer Is Representing: _____

POWER OF ATTORNEY

AMERICAN CONTRACTORS INDEMNITY COMPANY UNITED STATES SURETY COMPANY U.S. SPECIALTY INSURANCE COMPANY

KNOW ALL MEN BY THESE PRESENTS: That American Contractors Indemnity Company, a California corporation, United States Surety Company, a Maryland corporation and U.S. Specialty Insurance Company, a Texas corporation (collectively, the "Companies"), do by these presents make, constitute and appoint:

John G. Maloney, Mark D. Iatarola or Helen Maloney of Escondido, California

its true and lawful Attorney(s)-in-fact, each in their separate capacity if more than one is named above, with full power and authority hereby conferred in its name, place and stead, to execute, acknowledge and deliver any and all bonds, recognizances, undertakings or other instruments or contracts of suretyship to include riders, amendments, and consents of surety, providing the bond penalty does not exceed *****Fifteen Million***** Dollars (\$**15,000,000.00**).

This Power of Attorney shall expire without further action on December 08, 2016. This Power of Attorney is granted under and by authority of the following resolutions adopted by the Boards of Directors of the Companies:

Be it Resolved, that the President, any Vice-President, any Assistant Vice-President, any Secretary or any Assistant Secretary shall be and is hereby vested with full power and authority to appoint any one or more suitable persons as Attorney(s)-in-Fact to represent and act for and on behalf of the Company subject to the following provisions:

Attorney-in-Fact may be given full power and authority for and in the name of and on behalf of the Company, to execute, acknowledge and deliver, any and all bonds, recognizances, contracts, agreements or indemnity and other conditional or obligatory undertakings, including any and all consents for the release of retained percentages and/or final estimates on engineering and construction contracts, and any and all notices and documents canceling or terminating the Company's liability thereunder, and any such instruments so executed by any such Attorney-in-Fact shall be binding upon the Company as if signed by the President and sealed and effected by the Corporate Secretary.

Be it Resolved, that the signature of any authorized officer and seal of the Company heretofore or hereafter affixed to any power of attorney or any certificate relating thereto by facsimile, and any power of attorney or certificate bearing facsimile signature or facsimile seal shall be valid and binding upon the Company with respect to any bond or undertaking to which it is attached.

IN WITNESS WHEREOF, The Companies have caused this instrument to be signed and their corporate seals to be hereto affixed, this 10th day of December, 2012.

AMERICAN CONTRACTORS INDEMNITY COMPANY UNITED STATES SURETY COMPANY U.S. SPECIALTY INSURANCE COMPANY

Corporate Seals



[Signature] Daniel P. Aguilar, Vice President

State of California

County of Los Angeles SS:

On 10th day of December, 2012, before me, Vanessa Wright, a notary public, personally appeared Daniel P. Aguilar, Vice President of American Contractors Indemnity Company, United States Surety Company and U.S. Specialty Insurance Company who proved to me on the basis of satisfactory evidence to be the person whose name is subscribed to the within instrument and acknowledged to me that he executed the same in his authorized capacity, and that by his signature on the instrument the person(s), or the entity upon behalf of which the person(s) acted, executed the instrument.

I certify under PENALTY OF PERJURY under the laws of the State of California that the foregoing paragraph is true and correct. WITNESS my hand and official seal.

Signature [Signature] (Seal)

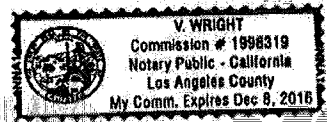

I, Jeannie Lee, Assistant Secretary of American Contractors Indemnity Company, United States Surety Company and U.S. Specialty Insurance Company, do hereby certify that the above and foregoing is a true and correct copy of a Power of Attorney, executed by said Companies, which is still in full force and effect; furthermore, the resolutions of the Boards of Directors, set out in the Power of Attorney are in full force and effect.

In Witness Whereof, I have hereunto set my hand and affixed the seals of said Companies at Los Angeles, California this 10TH day of JUNE, 2013

Corporate Seals

Bond No. 1000957121 Agency No. 4013



[Signature] Jeannie Lee, Assistant Secretary

CONTRACTOR CERTIFICATION

DRUG-FREE WORKPLACE

PROJECT TITLE: KELTON ROAD SIDEWALK IMPROVEMENTS

I hereby certify that I am familiar with the requirements of San Diego City Council Policy No. 100-17 regarding Drug-Free Workplace as outlined in the WHITEBOOK, Section 7-13.3, "Drug-Free Workplace", of the project specifications, and that;

HTA ENGINEERING & CONSTRUCTION, INC.

(Name under which business is conducted)

has in place a drug-free workplace program that complies with said policy. I further certify that each subcontract agreement for this project contains language which indicates the subcontractor's agreement to abide by the provisions of subdivisions a) through c) of the policy as outlined.

Signed Hatim T. Askar

Printed Name Hatim T. Askar

Title President

CONTRACTOR CERTIFICATION

AMERICAN WITH DISABILITIES ACT (ADA) COMPLIANCE CERTIFICATION

PROJECT TITLE: KELTON ROAD SIDEWALK IMPROVEMENTS

I hereby certify that I am familiar with the requirements of San Diego City Council Policy No. 100-4 regarding the American With Disabilities Act (ADA) outlined in the WHITEBOOK, Section 7-13.2, "American With Disabilities Act", of the project specifications, and that;

HTA ENGINEERING & CONSTRUCTION, INC.

(Name under which business is conducted)

has in place workplace program that complies with said policy. I further certify that each subcontract agreement for this project contains language which indicates the subcontractor's agreement to abide by the provisions of the policy as outlined.

Signed Mattin T. Askar

Printed Name Mattin T. Askar

Title President

CONTRACTOR CERTIFICATION

CONTRACTOR STANDARDS – PLEDGE OF COMPLIANCE

PROJECT TITLE: KELTON ROAD SIDEWALK IMPROVEMENTS

I declare under penalty of perjury that I am authorized to make this certification on behalf of HTA ENGINEERING & CONSTRUCTION, INC., as Contractor, that I am familiar with the requirements of City of San Diego Municipal Code § 22.3224 regarding Contractor Standards as outlined in the WHITEBOOK, Section 7-13.4, ("Contractor Standards"), of the project specifications, and that Contractor has complied with those requirements.

I further certify that each of the Contractor's subcontractors whose subcontracts are greater than \$50,000 in value has completed a Pledge of Compliance attesting under penalty of perjury of having complied with City of San Diego Municipal Code § 22.3224.

Dated this 11th Day of June, 2013.

Signed Natim T. Askan

Printed Name Natim T. Askan

Title President

AFFIDAVIT OF DISPOSAL

WHEREAS, on the _____ DAY OF _____, _____, the undersigned entered into and executed a contract with the City of San Diego, a municipal corporation, for:

KELTON ROAD SIDEWALK IMPROVEMENTS
(Name of Project)

as particularly described in said contract and identified as **L-13-5607-DBB-1-A**; SAP No. (WBS/CC/IO) **S-10154** and **WHEREAS**, the specification of said contract requires the Contractor to affirm that "all brush, trash, debris, and surplus materials resulting from this project have been disposed of in a legal manner"; and **WHEREAS**, said contract has been completed and all surplus materials disposed of:

NOW, THEREFORE, in consideration of the final payment by the City of San Diego to said Contractor under the terms of said contract, the undersigned Contractor, does hereby affirm that all surplus materials as described in said contract have been disposed of at the following location(s)

and that they have been disposed of according to all applicable laws and regulations.

Dated this _____ DAY OF _____, _____.

Contractor
by

ATTEST:

State of _____
County of _____

On this _____ DAY OF _____, 2____, before the undersigned, a Notary Public in and for said County and State, duly commissioned and sworn, personally appeared _____
_____ known to me to be the _____ Contractor named in the foregoing Release, and whose name is subscribed thereto, and acknowledged to me that said Contractor executed the said Release.

Notary Public in and for said County and State

COMPANY LETTERHEAD
CERTIFICATE OF COMPLIANCE

Materials and Workmanship Compliance

For Contract or Task _____

I certify that the material listed below complies with the materials and workmanship requirements of the Caltrans Contract Plans, Special Provisions, Standard Specifications, and Standard Plans for the contract listed above.

I also certify that I am an official representative for _____, the manufacturer of the material listed above. Furthermore, I certify that where California test methods, physical or chemical test requirements are part of the specifications, that the manufacturer has performed the necessary quality control to substantiate this certification.

Material Description:

Manufacturer: _____
Model: _____
Serial Number (if applicable) _____
Quantity to be supplied: _____
Remarks: _____

Signed by: _____

Printed Name: _____

Title: _____

Company: _____

Date: _____

**City of San Diego
Engineering and Capital Projects, Field Division**

NOTICE OF MATERIALS TO BE USED

To: _____ Date: _____, 20__
Resident Engineer

You are hereby notified that the materials required for use under Contract No. _____
for construction of _____
_____ in the City of San Diego, will be obtained from sources herein designated.

CONTRACT ITEM NO. (Bid Item)	KIND OF MATERIAL (Category)	NAME AND ADDRESS WHERE MATERIAL CAN BE INSPECTED (At Source)

It is requested that you arrange for a sampling, testing, and inspection of the materials prior to delivery, in accordance with Section 4-1.11 of the WHITEBOOK, where it is practicable, and in accordance with your policy. It is understood that source inspection does not relieve the Contractor of full responsibility for incorporating in the work, materials that comply in all respects with the contract plans and specifications, nor does it preclude subsequent rejection of materials found to be undesirable or unsuitable.

Distribution:

Supplier

Yours truly,

Signature of Supplier

Address

Phone Number: _____

SUPPLEMENTARY SPECIAL PROVISIONS (SSP)

SUPPLEMENTARY SPECIAL PROVISIONS

The following Supplementary Special Provisions (SSP) modifies the following documents:

- 1) Standard Specifications for Public Works Construction (The GREENBOOK) currently in effect.
 - 2) The City of San Diego Standard Specifications for Public Works Construction (The WHITEBOOK).
-

SECTION 1 – TERMS, DEFINITIONS, ABBREVIATIONS, UNITS OF MEASURE, AND SYMBOLS

1-2 TERMS AND DEFINITIONS.

Normal Working Hours. To the City Supplements, ADD the following:

The Normal Working Hours shall be between school's student drop-off in the morning (AM hrs TBD) and pick-up (afternoon) hours. Contact Henry Johnson Elementary School at (619) 264-0103. Stop & Restart work minimum fifteen minutes before or after school pick up or drop-off time, this includes providing safe pedestrian access including crossing and traffic controls to be removed along the frontage of the Johnson Elementary School.

SECTION 2 - SCOPE AND CONTROL OF WORK

2-3.2 Self Performance. DELETE in its entirety and SUBSTITUTE with the following:

1. You must perform, with your own organization, Contract work amounting to at least 50% of the base bid alone or base bid and any additive or deductive alternate(s) that together when added or deducted form the basis of award.
2. The self performance percentage requirement will be waived for contracts when a "B" License is required or allowed.

2-14.3 Coordination. To the City Supplements, ADD the following:

Other adjacent City project(s) is (are) scheduled for construction for the same time period in the vicinity of Encanto Neighborhood, Mid-City Area. See Appendix "E" for approximate location. Coordinate the Work with the adjacent project as listed below:

- a) Pipeline Rehabilitation, Laila Nasrawi, phone no. (619) 533-4619

SECTION 4 - CONTROL OF MATERIALS

4-1.6 Trade Names or Equals. ADD the following:

You must submit your list of proposed substitutions for “an equal” (“or equal”) item(s) **no less than 15 Working Days prior to Bid due date** and on a City form when provided by the City.

SECTION 6 - PROSECUTION, PROGRESS AND ACCEPTANCE OF WORK

ADD:

6-2.2 General Working Hours Restrictions.

6-2.2.1 General. This project is subject to date and time restrictions for work performed in the vicinity of schools. The specific dates and times for these restrictions are subject to change. The Contractor shall verify the most current date and item restrictions with the City Engineer prior to start of construction. The Contractor shall also reconfirm these restrictions with the City Engineer prior to the start of any phase of work subject to the restrictions. Additionally, the Contractor shall coordinate with the City Engineer to establish the vicinity around each school within which the work restrictions apply. The Contractor shall assume that work may not be performed within the vicinity of a school when the work restrictions are in effect. The following date and time restrictions apply to this project.

6-2.2.2 Date Restrictions. Date restrictions for Johnson Elementary School on year round calendar. Work restrictions apply on all dates that school is in session. School is in session on all dates except the following general time periods:

Year Round School Calendar:

1. Weekends (Saturday and Sunday)
2. National and School Specific Holidays
3. Thanksgiving Break (one week in November)
4. Winter Break (four weeks in December/January)
5. Spring Break (three weeks in April)
6. Summer Break (six weeks in July/August)
7. Statewide Testing (three weeks in May/June)

6-2.2.3 Time Restrictions. Work time restrictions apply on any day that school is in session. Work must stop during the work restrictions and can begin after the work restriction, this includes but is not limited to: remove all traffic controls, patch up any sidewalk work necessary provide full pedestrian access on sidewalks, provide a safe crossing along the frontage of Johnson Elementary School and any other items as direction by the Engineer. The work restrictions for Johnson Elementary School will be in place during the following general times:

1. Between 7:15 am and 7:45 am Monday through Friday

2. Between 1:50 pm and 2:20 pm Monday, Wednesday, Thursday, and Friday
3. Between 11:00 am and 11:30 am Tuesday

SECTION 7 - RESPONSIBILITIES OF THE CONTRACTOR

7-3 **LIABILITY INSURANCE.** DELETE in its entirety and SUBSTITUTE with the following:

The insurance provisions herein must not be construed to limit your indemnity obligations contained in the Contract.

7-3.1 **Policies and Procedures.**

1. You must procure the insurance described below, at its sole cost and expense, to provide coverage against claims for loss including injuries to persons or damage to property, which may arise out of or in connection with the performance of the Work by you, your agents, representatives, officers, employees or Subcontractors.
2. Insurance coverage for property damage resulting from your operations is on a replacement cost valuation. The market value will not be accepted.
3. You must maintain this insurance for the duration of this contract and at all times thereafter when you are correcting, removing, or replacing Work in accordance with this contract. Your liabilities under the Contract, e.g., your indemnity obligations, is not deemed limited to the insurance coverage required by this contract.
4. Payment for insurance is included in the various items of Work as bid by you, and except as specifically agreed to by the City in writing, you are not entitled to any additional payment. Do not begin any work under this contract until you have provided and the City has approved all required insurance.
5. Policies of insurance must provide that the City is entitled to 30 days (10 days for cancellation due to non-payment of premium) prior written notice of cancellation or non-renewal of the policy. Maintenance of specified insurance coverage is a material element of the Contract. Your failure to maintain or renew coverage or to provide evidence of renewal during the term of the Contract may be treated by the City as a material breach of the Contract.

7-3.2 **Types of Insurance.**

7-3.2.1 **Commercial General Liability Insurance.**

1. Commercial General Liability Insurance must be written on the current version of the ISO Occurrence form CG 00 01 07 98 or an equivalent form providing coverage at least as broad.
2. The policy must cover liability arising from premises and operations, XCU (explosions, underground, and collapse), independent contractors,

products/completed operations, personal injury and advertising injury, bodily injury, property damage, and liability assumed under an insured’s contract (including the tort liability of another assumed in a business contract).

3. There must be no endorsement or modification limiting the scope of coverage for either “insured vs. insured” claims or contractual liability. You must maintain the same or equivalent insurance for at least 10 years following completion of the Work.
4. All costs of defense must be outside the policy limits. Policy coverage must be in liability limits of not less than the following:

<u>General Annual Aggregate Limit</u>	<u>Limits of Liability</u>
Other than Products/Completed Operations	\$2,000,000
Products/Completed Operations Aggregate Limit	\$2,000,000
Personal Injury Limit	\$1,000,000
Each Occurrence	\$1,000,000

7-3.2.2 Commercial Automobile Liability Insurance.

1. You must provide a policy or policies of Commercial Automobile Liability Insurance written on the current version of the ISO form CA 00 01 12 90 or later version or equivalent form providing coverage at least as broad in the amount of \$1,000,000 combined single limit per accident, covering bodily injury and property damage for owned, non-owned, and hired automobiles (“Any Auto”).
2. All costs of defense must be outside the limits of the policy.

7-3.3 Rating Requirements. Except for the State Compensation Insurance Fund, all insurance required by this contract as described herein must be carried only by responsible insurance companies with a rating of, or equivalent to, at least “A-, VI” by A.M. Best Company, that are authorized by the California Insurance Commissioner to do business in the State, and that have been approved by the City.

7-3.3.1 Non-Admitted Carriers. The City will accept insurance provided by non-admitted, “surplus lines” carriers only if the carrier is authorized to do business in the State and is included on the List of Approved Surplus Lines Insurers (LASLI list).

All policies of insurance carried by non-admitted carriers must be subject to all of the requirements for policies of insurance provided by admitted carriers described herein.

7-3.4 Evidence of Insurance. Furnish to the City documents e.g., certificates of insurance and endorsements evidencing the insurance required herein, and furnish renewal documentation prior to expiration of this insurance. Each required document must be signed by the insurer or a person authorized by the insurer to bind coverage on its behalf. We reserve the right to require complete, certified copies of all insurance policies required herein.

7-3.5 Policy Endorsements.

7-3.5.1 Commercial General Liability Insurance

7-3.5.1.1 Additional Insured.

- a) You must provide at your expense policy endorsement written on the current version of the ISO Occurrence form CG 20 10 11 85 or an equivalent form providing coverage at least as broad.
- b) To the fullest extent allowed by law e.g., California Insurance Code §11580.04, the policy must be endorsed to include the City and its respective elected officials, officers, employees, agents, and representatives as additional insured.
- c) The additional insured coverage for projects for which the Engineer's Estimate is \$1,000,000 or more must include liability arising out of: (a) Ongoing operations performed by you or on your behalf, (b) your products, (c) your work, e.g., your completed operations performed by you or on your behalf, or (d) premises owned, leased, controlled, or used by you.
- d) The additional insured coverage for projects for which the Engineer's Estimate is less than \$1,000,000 must include liability arising out of: (a) Ongoing operations performed by you or on your behalf, (b) your products, or (c) premises owned, leased, controlled, or used by you.

7-3.5.1.2 Primary and Non-Contributory Coverage. The policy must be endorsed to provide that the coverage with respect to operations, including the completed operations, if appropriate, of the Named Insured is primary to any insurance or self-insurance of the City and its elected officials, officers, employees, agents and representatives. Further, it must provide that any insurance maintained by the City and its elected officials, officers, employees, agents and representatives must be in excess of your insurance and must not contribute to it.

7-3.5.1.3 Project General Aggregate Limit.

The policy or policies must be endorsed to provide a Designated Construction Project General Aggregate Limit that will apply only to the Work. Only claims payments which arise from the Work must reduce the Designated Construction Project General Aggregate Limit. The Designated Construction Project General Aggregate Limit must be in addition to the aggregate limit provided for the products-completed operations hazard.

7-3.5.2 Commercial Automobile Liability Insurance.

7-3.5.2.1 Additional Insured. Unless the policy or policies of Commercial Auto Liability Insurance are written on an ISO form CA 00 01 12 90 or a later version of this form or equivalent form providing coverage at least as broad, the policy must be endorsed to include the City and its respective elected officials, officers, employees, agents, and representatives as additional insured, with respect to liability arising out of automobiles owned, leased, hired or borrowed by you or on your behalf. This

endorsement is limited to the obligations permitted by California Insurance Code §11580.04.

7-3.6 Deductibles and Self-Insured Retentions. You must pay for all deductibles and self-insured retentions. You must disclose deductibles and self-insured retentions to the City at the time the evidence of insurance is provided.

7-3.7 Reservation of Rights. The City reserves the right, from time to time, to review your insurance coverage, limits, deductibles and self-insured retentions to determine if they are acceptable to the City. The City will reimburse you, without overhead, profit, or any other markup, for the cost of additional premium for any coverage requested by the Engineer but not required by this contract.

7-3.8 Notice of Changes to Insurance. You must notify the City 30 days prior to any material change to the policies of insurance provided under this contract.

7-3.9 Excess Insurance. Policies providing excess coverage must follow the form of the primary policy or policies e.g., all endorsements.

7-4 WORKERS' COMPENSATION INSURANCE. DELETE in its entirety and SUBSTITUTE with the following:

7-4.1 Workers' Compensation Insurance and Employers Liability Insurance.

1. In accordance with the provisions of §3700 of the California Labor Code, you must provide at your expense Workers' Compensation Insurance and Employers Liability Insurance to protect you against all claims under applicable state workers compensation laws. The City, its elected officials, and employees will not be responsible for any claims in law or equity occasioned by your failure to comply with the requirements of this section.

2. Limits for this insurance must be not less than the following:

<u>Workers' Compensation</u>	<u>Statutory Employers Liability</u>
Bodily Injury by Accident	\$1,000,000 each accident
Bodily Injury by Disease	\$1,000,000 each employee
Bodily Injury by Disease	\$1,000,000 policy limit

3. By signing and returning the Contract you certify that you are aware of the provisions of §3700 of the Labor Code which require every employer to be insured against liability for worker's compensation or to undertake self-insurance in accordance with the provisions of that code and you must comply with such provisions before commencing the Work as required by §1861 of the California Labor Code.

7-4.1.1 Waiver of Subrogation.

The policy or policies must be endorsed to provide that the insurer will waive all rights of subrogation against the City, and its respective elected officials, officers,

employees, agents, and representatives for losses paid under the terms of the policy or policies and which arise from work performed by the Named Insured for the City.

7-10.2.3 Traffic Control Devices. To the City Supplements, ADD the following:

20. A safe crossing on Kelton Road in front of Johnson Elementary School should be maintained at all times. This may include installation of a temporary crosswalk with temporary striping on Kelton Road adjacent to Johnson Elementary School. Sidewalk pedestrian access on both sides of the roadway along the frontage of Johnson Elementary School should be maintained during the work restriction times in Section 6-2.2.3. This may require that the sidewalks at the existing crosswalk be patched up for pick-up and drop-off times to provide safe pedestrian access along the frontage of the school.

7-10.2.6 Measurement and Payment. Add the following:

The payment for the traffic control shall include full compensation for all labor, materials, equipment, temporary striping, removal of temporary striping, and any materials or equipment required to perform the work or as directed by the Engineer.

7-10.5.3 Steel Plate Covers. Table 7-10.5.3(A), REVISE the plate thickness for 5'-3" trench width to read 1 3/4".

7-15 INDEMNIFICATION AND HOLD HARMLESS AGREEMENT. To the City Supplements, fourth paragraph, last sentence, DELETE in its entirety and SUBSTITUTE with the following:

Your duty to indemnify and hold harmless does not include any claims or liability arising from the established active or sole negligence, or willful misconduct of the City, its officers, or employees.

SECTION 8 - FACILITIES FOR AGENCY PERSONNEL

8-2 FIELD OFFICE FACILITIES. To the City Supplements, DELETE in its entirety.

SECTION 9 - MEASUREMENT AND PAYMENT

9-3.2.5 Withholding of Payment. To the City Supplements, item i), DELETE in its entirety and SUBSTITUTE with the following:

i) Your failure to comply with 7-2.3, "PAYROLL RECORDS" and 2-16, "CONTRACTOR REGISTRATION AND ELECTRONIC REPORTING SYSTEM."

SECTION 209 – STREET LIGHTING AND TRAFFIC SIGNAL MATERIALS

209-6.4 Induction Cobra Head Luminaire. To the City Supplements, CORRECT certain section numbering as follows:

OLD SECTION NUMBER	TITLE	NEW SECTION NUMBER
209-6.4.7	Luminaire Identification	209-6.4.8
209-6.4.8	Photometric Documentation	209-6.4.9
209-6.4.9	Quality Assurance	209-6.4.10

SECTION 300 – EARTHWORK

300-1.4 Payment. To the City Supplements, paragraph (2), DELETE in its entirety and SUBSTITUTE with the following:

2. Payment for existing pavement removal and disposal of up to 12” thick, within the excavation e.g., trench limits, shall be included in the Bid item for installation of the mains or the Work item that requires pavement removal.

300-1.4 Payment. To the City Supplements, ADD the following:

7. The lump sum price for Clearing and Grubbing shall include protection or , removal of existing fences, of all miscellaneous concrete, pavement, curb and gutter, sidewalk, and the adjustment of all water meter boxes sewer manholes, pull boxes, hand holes and all other existing improvements that are shown on the plans for removal, directed by the Engineer to be removed, or otherwise required to perform the work.

300-2.9 Payment. ADD the following:

The contract unit price bid for Unclassified Excavation shall include full compensation for all cost necessary for excavating and grading excess dirt behind new sidewalks including the removal, sloping, grading, compaction, rounding tops and ends of excavation, treatment, storage, stockpiling, transportation within the project side, loading, disposal, export, and hauling of unsuitable, wet, or surplus material off site.

SECTION 303 – CONCRETE AND MASONRY CONSTRUCTION

303-5.9 Measurement and Payment. ADD the following:

Payment for square feet of PCC Sidewalk shall include full compensation for all labor, materials, equipment, meter box and pull box adjustments, sign relocations, and incidentals required to install PCC Sidewalks, per plan, per specifications, and as directed by the Engineer.

Payment for linear feet of Type “G” Curb & Gutter per SDG-151 shall include full compensation for all labor, materials, grading, repair of adjacent pavement, equipment, painting of red curbs, and incidentals required to install curb and gutter in all locations including adjacent to driveways, per plan, per specifications, and as directed by the Engineer.

Payment for sidewalk grade beam with integrated chain link fence shall include for compensation for all labor, materials, grading, and incidentals required to install detailed grade beam and to salvage existing fence and relocate new poles with hardware on the grade beam , per plans, per specifications, and as directed by Resident Engineer.

SECTION 304 – METAL FABRICATION AND CONSTRUCTION

304-1.12 Measurement and Payment. ADD the following:

Payment for linear foot of Repair Existing Fence shall include new posts in concrete.

304-2.2.3 Measurement and Payment. ADD the following:

Payment for linear foot of Metal Beam Guardrail per Caltrans Drawing No. A77A1 shall include full compensation for all labor, materials, demolition, disposal, excavation, grading, repair of adjacent pavement, equipment, remove and salvage or repair existing metal beam guardrail, and incidentals required to install the guardrail per plan, per specifications, and as directed by the Engineer.

Salvaging shall be include the removal, disassembly, preparation, marking, bundling, packing, tagging, hauling and stockpiling of salvaged materials or facilities as directed by the Engineer. Materials designated to be salvaged or reused that are damaged, as determined by the Engineer, shall be segregated from undamaged material. The damaged material shall become the property of the Contractor and shall be disposed of in conformance with these Special Provisions. Materials to be salvaged or reused that are damaged as a result of the Contractor’s operations and must still be reused shall be repaired by the Contractor, at the Contractor’s expense, to the satisfaction of the Engineer. Materials that must be reused that are damaged beyond repair as a result of the contractor’s operations shall be disposed of and replaced at the Contractor’s expense.

The lineal feet payment for Metal Bean Guardrail with End Anchor Assembly per Caltrans Drawing No. A77H1 and for Metal Beam Railing Terminal System (Type SRT) per Caltrans Drawing No. A77L1 shall include full compensation for installation of salvaged metal beam guardrail or new metal beam guardrail all labor, materials, demolition, disposal, excavation, grading, backfill post holes, repair of adjacent pavement, equipment, and incidentals required to install the guardrail, end anchor assembly and, railing terminal system per plan, per specifications, and as directed by the Engineer.

All materials including posts, blocks, and hardware and guardrail if necessary shall be new, with the exception of the salvaged metal beams.

304-5 **Payment.** To the City Supplement, ADD the following:

The payment for signing shall include full compensation for the labor, materials, equipment for the removal of existing signs, relocation of existing signs, installation of new signs as indicated on the plans and necessary to complete the work and/or as may be directed by the Engineer. These signs include but are not limited to: advance warning signs, school signs, and any other roadway signs as indicated on the plans or directed by the Engineer.

SECTION 306 – UNDERGROUND CONDUIT CONSTRUCTION

306-1 **OPEN TRENCH OPERATIONS.** To the City Supplements, CORRECT certain section numbering as follows:

OLD SECTION NUMBER	TITLE	NEW SECTION NUMBER
306-1.8	House Connection Sewer (Laterals) and Cleanouts	306-1.9
306-1.7.1	Payment	306-1.9.1
306-1.7.2	Sewer Lateral with Private Replumbing	306-1.9.2
306-1.7.2.1	Location	306-1.9.2-1
306-1.7.2.2	Permits	306-1.9.2-2
306-1.7.2.3	Submittals	306-1.9.2-3
306-1.7.2.4	Trenchless Construction	306-1.9.2-4
306-1.7.2.5	Payment	306-1.9.2-5
306-1.7.3.6	Private Pump Installation	306-1.9.2-6
306-1.7.3.7	Payment	306-1.9.2-7

306-1.6 **Basis of Payment for Open Trench Installations.** ADD the following:

Payment for imported backfill when the Contractor elects to import material from a source outside the project limits and when authorized by the Engineer shall be included in the Bid unit price for Imported Backfill. The price shall include the removal and disposal of unsuitable materials.

SECTION 701 – WATER POLLUTION CONTROL

701-11 **Post-Construction Requirements.** To the City Supplement, second paragraph, ADD the following:

Comply with the following post-construction requirements:

Inlet markers.

SECTION 707 – RESOURCE DISCOVERIES

**ADD:
707-1.1**

Environmental Document. The City of San Diego Environmental Analysis Section (EAS) of the Development Services Department has prepared **Notice of Exemption** for **Kelton Road Sidewalk Improvements**, DEP No. **S-10154**, as referenced in the Contract Appendix. You must comply with all requirements of the **Notice of Exemption** as set forth in the Contract Appendix.

Compliance with the City’s environmental document is included in the various Bid items, unless a bid item has been provided.

END OF SUPPLEMENTARY SPECIAL PROVISIONS (SSP)

SUPPLEMENTARY SPECIAL PROVISIONS

APPENDICES

APPENDIX A
NOTICE OF EXEMPTION

NOTICE OF EXEMPTION

(Check one or both)

TO: X RECORDER/COUNTY CLERK
P.O. BOX 1750, MS A-33
1600 PACIFIC HWY, ROOM 260
SAN DIEGO, CA 92101-2422

FROM: CITY OF SAN DIEGO
DEVELOPMENT SERVICES DEPARTMENT
1222 FIRST AVENUE, MS 501
SAN DIEGO, CA 92101

OFFICE OF PLANNING AND RESEARCH
1400 TENTH STREET, ROOM 121
SACRAMENTO, CA 95814

PROJECT NO.: S-10154

PROJECT TITLE: Kelton Road Pedestrian Improvements

PROJECT LOCATION-SPECIFIC: The project is located along a portion of Kelton Road between Zircon Street to the north and Luber Street to the south within the Encanto Neighborhood of the Southeastern San Diego Community Planning Area.

PROJECT LOCATION-CITY/COUNTY: San Diego/San Diego

DESCRIPTION OF NATURE AND PURPOSE OF THE PROJECT: The project would require the removal and replacement of a portion of pavement, curb, gutter, sidewalk, guardrail and guardrail end treatments along Kelton Road in order to replace an existing crosswalk with a new grid-powered lighted crosswalk with the goal of providing better access and increasing pedestrian safety. Additional improvements would include installation of two new concrete pop-outs and two new curb ramps. All work would occur within the City of San Diego right-of-way.

NAME OF PUBLIC AGENCY APPROVING PROJECT: City of San Diego

NAME OF PERSON OR AGENCY CARRYING OUT PROJECT: City of San Diego, E&CP Dept/Jason Guise
600 B Street, Suite 800 (MS 908A)
San Diego, CA 92101
619 533-4665

EXEMPT STATUS: (CHECK ONE)

- () MINISTERIAL (SEC. 21080(b)(1); 15268);
() DECLARED EMERGENCY (SEC. 21080(b)(3); 15269(a));
() EMERGENCY PROJECT (SEC. 21080(b)(4); 15269 (b)(c))
(X) CATEGORICAL EXEMPTION: 15301(C) (Existing Facilities), 15302 (Replacement or Reconstruction) and 15303 (New Construction or Conversion of Small Structures)
() STATUTORY EXEMPTIONS:

REASONS WHY PROJECT IS EXEMPT: The project meets the criteria set forth in CEQA Section 15301, 15302 and 15303 which allow for the repair, maintenance and minor alteration of existing streets, sidewalks, gutters and similar facilities involving no or negligible expansion of use beyond existing conditions; replacement or reconstruction of existing structures and facilities where the new structure/facility will be located on the same site as the structure/facility replaced and has substantially the same purpose and capacity as the structure/facility replaced; construction of limited small facilities or structures including public right-of-way infrastructure improvements; and where the exceptions listed in CEQA Section 15300.2 would not apply.

LEAD AGENCY CONTACT PERSON: Jean Cameron

TELEPHONE: (619) 446-5379

IF FILED BY APPLICANT:

- 1. ATTACH CERTIFIED DOCUMENT OF EXEMPTION FINDING.
2. HAS A NOTICE OF EXEMPTION BEEN FILED BY THE PUBLIC AGENCY APPROVING THE PROJECT?
() YES () NO

IT IS HEREBY CERTIFIED THAT THE CITY OF SAN DIEGO HAS DETERMINED THE ABOVE ACTIVITY TO BE EXEMPT FROM CEQA

Jean Cameron signature
JEAN CAMERON/SENIOR PLANNER

3/8/11
DATE

CHECK ONE:

- (X) SIGNED BY LEAD AGENCY
() SIGNED BY APPLICANT

DATE RECEIVED FOR FILING WITH COUNTY CLERK OR OPR:

APPENDIX B
FIRE HYDRANT METER PROGRAM

CITY OF SAN DIEGO CALIFORNIA DEPARTMENT INSTRUCTIONS	NUMBER DI 55.27	DEPARTMENT Water Department
SUBJECT FIRE HYDRANT METER PROGRAM (FORMERLY: CONSTRUCTION METER PROGRAM)	PAGE 1 OF 10	EFFECTIVE DATE October 15, 2002
	SUPERSEDES DI 55.27	DATED April 21, 2000

1. **PURPOSE**

- 1.1 To establish a Departmental policy and procedure for issuance, proper usage and charges for fire hydrant meters.

2. **AUTHORITY**

- 2.1 All authorities and references shall be current versions and revisions.
- 2.2 San Diego Municipal Code (NC) Chapter VI, Article 7, Sections 67.14 and 67.15
- 2.3 Code of Federal Regulations, Safe Drinking Water Act of 1986
- 2.4 California Code of Regulations, Titles 17 and 22
- 2.5 California State Penal Code, Section 498B.0
- 2.6 State of California Water Code, Section 110, 500-6, and 520-23
- 2.7 Water Department Director

Reference

- 2.8 State of California Guidance Manual for Cross Connection Programs
- 2.9 American Water Works Association Manual M-14, Recommended Practice for Backflow Prevention
- 2.10 American Water Works Association Standards for Water Meters
- 2.11 U.S.C. Foundation for Cross Connection Control and Hydraulic Research Manual

3. **DEFINITIONS**

- 3.1 **Fire Hydrant Meter:** A portable water meter which is connected to a fire hydrant for the purpose of temporary use. (These meters are sometimes referred to as Construction Meters.)

CITY OF SAN DIEGO CALIFORNIA DEPARTMENT INSTRUCTIONS	NUMBER DI 55.27	DEPARTMENT Water Department
SUBJECT FIRE HYDRANT METER PROGRAM (FORMERLY: CONSTRUCTION METER PROGRAM)	PAGE 2 OF 10	EFFECTIVE DATE October 15, 2002
	SUPERSEDES DI 55.27	DATED April 21, 2000

- 3.2 **Temporary Water Use:** Water provided to the customer for no longer than twelve (12) months.
- 3.3 **Backflow Preventor:** A Reduced Pressure Principal Assembly connected to the outlet side of a Fire Hydrant Meter.

4. **POLICY**

- 4.1 The Water Department shall collect a deposit from every customer requiring a fire hydrant meter and appurtenances prior to providing the meter and appurtenances (see Section 7.1 regarding the Fees and Deposit Schedule). The deposit is refundable upon the termination of use and return of equipment and appurtenances in good working condition.
- 4.2 Fire hydrant meters will have a 2 ½" swivel connection between the meter and fire hydrant. The meter shall not be connected to the 4" port on the hydrant. All Fire Hydrant Meters issued shall have a Reduced Pressure Principle Assembly (RP) as part of the installation. Spanner wrenches are the only tool allowed to turn on water at the fire hydrant.
- 4.3 The use of private hydrant meters on City hydrants is prohibited, with exceptions as noted below. All private fire hydrant meters are to be phased out of the City of San Diego. All customers who wish to continue to use their own fire hydrant meters must adhere to the following conditions:
 - a. Meters shall meet all City specifications and American Water Works Association (AWWA) standards.
 - b. Customers currently using private fire hydrant meters in the City of San Diego water system will be allowed to continue using the meter under the following conditions:
 - 1. The customer must submit a current certificate of accuracy and calibration results for private meters and private backflows annually to the City of San Diego, Water Department, Meter Shop.

CITY OF SAN DIEGO CALIFORNIA DEPARTMENT INSTRUCTIONS	NUMBER DI 55.27	DEPARTMENT Water Department
SUBJECT FIRE HYDRANT METER PROGRAM (FORMERLY: CONSTRUCTION METER PROGRAM)	PAGE 3 OF 10	EFFECTIVE DATE October 15, 2002
	SUPERSEDES DI 55.27	DATED April 21, 2000

2. The meter must be properly identifiable with a clearly labeled serial number on the body of the fire hydrant meter. The serial number shall be plainly stamped on the register lid and the main casing. Serial numbers shall be visible from the top of the meter casing and the numbers shall be stamped on the top of the inlet casing flange.
3. All meters shall be locked to the fire hydrant by the Water Department, Meter Section (see Section 4.7).
4. All meters shall be read by the Water Department, Meter Section (see Section 4.7).
5. All meters shall be relocated by the Water Department, Meter Section (see Section 4.7).
6. These meters shall be tested on the anniversary of the original test date and proof of testing will be submitted to the Water Department, Meter Shop, on a yearly basis. If not tested, the meter will not be allowed for use in the City of San Diego.
7. All private fire hydrant meters shall have backflow devices attached when installed.
8. The customer must maintain and repair their own private meters and private backflows.
9. The customer must provide current test and calibration results to the Water Department, Meter Shop after any repairs.
10. When private meters are damaged beyond repair, these private meters will be replaced by City owned fire hydrant meters.

CITY OF SAN DIEGO CALIFORNIA DEPARTMENT INSTRUCTIONS	NUMBER DI 55.27	DEPARTMENT Water Department
SUBJECT FIRE HYDRANT METER PROGRAM (FORMERLY: CONSTRUCTION METER PROGRAM)	PAGE 4 OF 10	EFFECTIVE DATE October 15, 2002
	SUPERSEDES DI 55.27	DATED April 21, 2000

11. When a private meter malfunctions, the customer will be notified and the meter will be removed by the City and returned to the customer for repairs. Testing and calibration results shall be given to the City prior to any re-installation.
12. The register shall be hermetically sealed straight reading and shall be readable from the inlet side. Registration shall be in hundred cubic feet.
13. The outlet shall have a 2 ½ "National Standards Tested (NST) fire hydrant male coupling.
14. Private fire hydrant meters shall not be transferable from one contracting company to another (i.e. if a company goes out of business or is bought out by another company).

4.4 All fire hydrant meters and appurtenances shall be installed, relocated and removed by the City of San Diego, Water Department. All City owned fire hydrant meters and appurtenances shall be maintained by the City of San Diego, Water Department, Meter Services.

4.5 If any fire hydrant meter is used in violation of this Department Instruction, the violation will be reported to the Code Compliance Section for investigation and appropriate action. Any customer using a fire hydrant meter in violation of the requirements set forth above is subject to fines or penalties pursuant to the Municipal Code, Section 67.15 and Section 67.37.

4.6 **Conditions and Processes for Issuance of a Fire Hydrant Meter**

Process for Issuance

- a. Fire hydrant meters shall only be used for the following purposes:
 1. Temporary irrigation purposes not to exceed one year.

CITY OF SAN DIEGO CALIFORNIA DEPARTMENT INSTRUCTIONS	NUMBER DI 55.27	DEPARTMENT Water Department
SUBJECT FIRE HYDRANT METER PROGRAM (FORMERLY: CONSTRUCTION METER PROGRAM)	PAGE 5 OF 10	EFFECTIVE DATE October 15, 2002
	SUPERSEDES DI 55.27	DATED April 21, 2000

2. Construction and maintenance related activities (see Tab 2).
 - b. No customer inside or outside the boundaries of the City of San Diego Water Department shall resell any portion of the water delivered through a fire hydrant by the City of San Diego Water Department.
 - c. The City of San Diego allows for the issuance of a temporary fire hydrant meter for a period not to exceed 12 months (365 days). An extension can only be granted in writing from the Water Department Director for up to 90 additional days. A written request for an extension by the consumer must be submitted at least 30 days prior to the 12 month period ending. No extension shall be granted to any customer with a delinquent account with the Water Department. No further extensions shall be granted.
 - d. Any customer requesting the issuance of a fire hydrant meter shall file an application with the Meter Section. The customer must complete a "Fire Hydrant Meter Application" (Tab 1) which includes the name of the company, the party responsible for payment, Social Security number and/or California ID, requested location of the meter (a detailed map signifying an exact location), local contact person, local phone number, a contractor's license (or a business license), description of specific water use, duration of use at the site and full name and address of the person responsible for payment.
 - e. At the time of the application the customer will pay their fees according to the schedule set forth in the Rate Book of Fees and Charges, located in the City Clerk's Office. All fees must be paid by check, money order or cashiers check, made payable to the City Treasurer. Cash will not be accepted.
 - f. No fire hydrant meters shall be furnished or relocated for any customer with a delinquent account with the Water Department.
 - g. After the fees have been paid and an account has been created, the

CITY OF SAN DIEGO CALIFORNIA DEPARTMENT INSTRUCTIONS	NUMBER DI 55.27	DEPARTMENT Water Department
SUBJECT FIRE HYDRANT METER PROGRAM (FORMERLY: CONSTRUCTION METER PROGRAM)	PAGE 6 OF 10	EFFECTIVE DATE October 15, 2002
	SUPERSEDES DI 55.27	DATED April 21, 2000

meter shall be installed within 48 hours (by the second business day). For an additional fee, at overtime rates, meters can be installed within 24 hours (within one business day).

4.7 Relocation of Existing Fire Hydrant Meters

- a. The customer shall call the Fire Hydrant Meter Hotline (herein referred to as "Hotline"), a minimum of 24 hours in advance, to request the relocation of a meter. A fee will be charged to the existing account, which must be current before a work order is generated for the meter's relocation.
- b. The customer will supply in writing the address where the meter is to be relocated (map page, cross street, etc). The customer must update the original Fire Hydrant Meter Application with any changes as it applies to the new location.
- c. Fire hydrant meters shall be read on a monthly basis. While fire hydrant meters and backflow devices are in service, commodity, base fee and damage charges, if applicable, will be billed to the customer on a monthly basis. If the account becomes delinquent, the meter will be removed.

4.8 Disconnection of Fire Hydrant Meter

- a. After ten (10) months a "Notice of Discontinuation of Service" (Tab 3) will be issued to the site and the address of record to notify the customer of the date of discontinuance of service. An extension can only be granted in writing from the Water Department Director for up to 90 additional days (as stated in Section 4.6C) and a copy of the extension shall be forwarded to the Meter Shop Supervisor. If an extension has not been approved, the meter will be removed after twelve (12) months of use.
- b. Upon completion of the project the customer will notify the Meter Services office via the Hotline to request the removal of the fire hydrant meter and appurtenances. A work order will be generated

CITY OF SAN DIEGO CALIFORNIA DEPARTMENT INSTRUCTIONS	NUMBER DI 55.27	DEPARTMENT Water Department
SUBJECT FIRE HYDRANT METER PROGRAM (FORMERLY: CONSTRUCTION METER PROGRAM)	PAGE 7 OF 10	EFFECTIVE DATE October 15, 2002
	SUPERSEDES DI 55.27	DATED April 21, 2000

for removal of the meter.

- c. Meter Section staff will remove the meter and backflow prevention assembly and return it to the Meter Shop. Once returned to the Meter Shop the meter and backflow will be tested for accuracy and functionality.
- d. Meter Section Staff will contact and notify Customer Services of the final read and any charges resulting from damages to the meter and backflow or its appurtenance. These charges will be added on the customer's final bill and will be sent to the address of record. Any customer who has an outstanding balance will not receive additional meters.
- e. Outstanding balances due may be deducted from deposits and any balances refunded to the customer. Any outstanding balances will be turned over to the City Treasurer for collection. Outstanding balances may also be transferred to any other existing accounts.

5. **EXCEPTIONS**

- 5.1 Any request for exceptions to this policy shall be presented, in writing, to the Customer Support Deputy Director, or his/her designee for consideration.

6. **MOBILE METER**

- 6.1 Mobile meters will be allowed on a case by case basis. All mobile meters will be protected by an approved backflow assembly and the minimum requirement will be a Reduced Pressure Principal Assembly. The two types of Mobile Meters are vehicle mounted and floating meters. Each style of meters has separate guidelines that shall be followed for the customer to retain service and are described below:

- a) **Vehicle Mounted Meters:** Customer applies for and receives a City owned Fire Hydrant Meter from the Meter Shop. The customer mounts the meter on the vehicle and brings it to the Meter Shop for

CITY OF SAN DIEGO CALIFORNIA DEPARTMENT INSTRUCTIONS	NUMBER DI 55.27	DEPARTMENT Water Department
SUBJECT FIRE HYDRANT METER PROGRAM (FORMERLY: CONSTRUCTION METER PROGRAM)	PAGE 8 OF 10	EFFECTIVE DATE October 15, 2002
	SUPERSEDES DI 55.27	DATED April 21, 2000

inspection. After installation is approved by the Meter Shop the vehicle and meter shall be brought to the Meter Shop on a monthly basis for meter reading and on a quarterly basis for testing of the backflow assembly. Meters mounted at the owner's expense shall have the one year contract expiration waived and shall have meter or backflow changed if either fails.

- b) **Floating Meters:** Floating Meters are meters that are not mounted to a vehicle. **(Note: All floating meters shall have an approved backflow assembly attached.)** The customer shall submit an application and a letter explaining the need for a floating meter to the Meter Shop. The Fire Hydrant Meter Administrator, after a thorough review of the needs of the customer, (i.e. number of jobsites per day, City contract work, lack of mounting area on work vehicle, etc.), may issue a floating meter. At the time of issue, it will be necessary for the customer to complete and sign the "Floating Fire Hydrant Meter Agreement" which states the following:

- 1) The meter will be brought to the Meter Shop at 2797 Caminito Chollas, San Diego on the third week of each month for the monthly read by Meter Shop personnel.
- 2) Every other month the meter will be read and the backflow will be tested. This date will be determined by the start date of the agreement.

If any of the conditions stated above are not met the Meter Shop has the right to cancel the contract for floating meter use and close the account associated with the meter. The Meter Shop will also exercise the right to refuse the issuance of another floating meter to the company in question.

Any Fire Hydrant Meter using reclaimed water shall not be allowed use again with any potable water supply. The customer shall incur the cost of replacing the meter and backflow device in this instance.

CITY OF SAN DIEGO CALIFORNIA DEPARTMENT INSTRUCTIONS	NUMBER DI 55.27	DEPARTMENT Water Department
SUBJECT FIRE HYDRANT METER PROGRAM (FORMERLY: CONSTRUCTION METER PROGRAM)	PAGE 9 OF 10	EFFECTIVE DATE October 15, 2002
	SUPERSEDES DI 55.27	DATED April 21, 2000

7. **FEE AND DEPOSIT SCHEDULES**

- 7.1 **Fees and Deposit Schedules:** The fees and deposits, as listed in the Rate Book of Fees and Charges, on file with the Office of the City Clerk, are based on actual reimbursement of costs of services performed, equipment and materials. These deposits and fees will be amended, as needed, based on actual costs. Deposits, will be refunded at the end of the use of the fire hydrant meter, upon return of equipment in good working condition and all outstanding balances on account are paid. Deposits can also be used to cover outstanding balances.

All fees for equipment, installation, testing, relocation and other costs related to this program are subject to change without prior notification. The Mayor and Council will be notified of any future changes.

8. **UNAUTHORIZED USE OF WATER FROM A HYDRANT**

- 8.1 Use of water from any fire hydrant without a properly issued and installed fire hydrant meter is theft of City property. Customers who use water for unauthorized purposes or without a City of San Diego issued meter will be prosecuted.
- 8.2 If any unauthorized connection, disconnection or relocation of a fire hydrant meter, or other connection device is made by anyone other than authorized Water Department personnel, the person making the connection will be prosecuted for a violation of San Diego Municipal Code, Section 67.15. In the case of a second offense, the customer's fire hydrant meter shall be confiscated and/or the deposit will be forfeited.
- 8.3 Unauthorized water use shall be billed to the responsible party. Water use charges shall be based on meter readings, or estimates when meter readings are not available.
- 8.4 In case of unauthorized water use, the customer shall be billed for all applicable charges as if proper authorization for the water use had been obtained, including but not limited to bi-monthly service charges, installation charges and removal charges.

CITY OF SAN DIEGO CALIFORNIA DEPARTMENT INSTRUCTIONS	NUMBER DI 55.27	DEPARTMENT Water Department
SUBJECT FIRE HYDRANT METER PROGRAM (FORMERLY: CONSTRUCTION METER PROGRAM)	PAGE 10 OF 10	EFFECTIVE DATE October 15, 2002
	SUPERSEDES DI 55.27	DATED April 21, 2000

- 8.5 If damage occurs to Water Department property (i.e. fire hydrant meter, backflow, various appurtenances), the cost of repairs or replacements will be charged to the customer of record (applicant).

Water Department Director

- Tabs: 1. Fire Hydrant Meter Application
2. Construction & Maintenance Related Activities With No Return To Sewer
3. Notice of Discontinuation of Service

APPENDIX

Administering Division: Customer Support Division

Subject Index: Construction Meters
Fire Hydrant
Fire Hydrant Meter Program
Meters, Floating or Vehicle Mounted
Mobile Meter
Program, Fire Hydrant Meter

Distribution: DI Manual Holders



Application For Fire Hydrant Meter

(EXHIBIT A)

For Office Use Only

2797 Caminito Chollas • San Diego, California 92105-5097
METER SHOP 619 527 7449
FAX 619 527 3125

NS Rec:	Fac #:
Date:	By:

Application Date:	Requested Install Date:
-------------------	-------------------------

Fire Hydrant Location: (Attach detailed map, Thomas Bros. map location or construction drawing.)

Specific Use of Water:

Any return to Sewer or Storm Drain, if so, explain:

Estimated Duration of Meter Use: Check Box if Reclaimed Water

Company Information

Company Name:

Mailing Address:

City: State: Zip Code: Phone: ()

*Business License #: *Contractor License #:

**A copy of the Contractor's License and/or Business License is required at the time of meter issuance.*

Name and Title of Agent: Phone: ()

Site Contact Name and Title: Phone: ()

Pager #: Cell: ()

Responsible Party Name: Title:

Social Security or Cal ID #: Phone: ()

Signature: Date:

Guarantees payment of all charges resulting from the use of this meter. Insures that employees of this organization understand the proper use of Fire Hydrant Meter.

Fire Hydrant Meter Removal Request

Check Box to Request Removal of Above Meter Requested Removal Date:

Provide current Meter location if different from above:

Signature: Title: Date:

Phone: () Pager: ()

For Office Use Only

<input type="checkbox"/> City Meter	<input type="checkbox"/> Private Meter		
CIS Account #:	Deposit Amount: \$	Fees Amount: \$	
Meter Serial #:	Meter Size:	Meter Make & Style:	
Backflow #:	Backflow Size:	Meter Make & Style:	
Name:	Signature:	Date:	

\$1,108.45 - FOR 24 HR INSTALLATION
 \$1,052.26 - FOR 48 HR INSTALLATION

FHM App Created: 11/2/00-htp

"Exhibit B"

CONSTRUCTION AND MAINTENANCE RELATED ACTIVITIES WITH NO RETURN TO SEWER:

**Auto Detailing
Backfilling
Combination Cleaners (Vactors)
Compaction
Concrete Cutters
Construction Trailers
Cross Connection Testing
Dust Control
Flushing Water Mains
Hydro blasting
Hydro Seeding
Irrigation (for establishing irrigation only; not continuing irrigation)
Mixing Concrete
Mobile Car Washing
Special Events
Street Sweeping
Water Tanks
Water Trucks
Window Washing**

Note: If there is any return to sewer or storm drain, then sewer and/or storm drain fees will be charged.

"Exhibit C"

Date

Name of Responsible Party
Company Name and address
Account Number: _____

Subject: Discontinuation of Fire Hydrant Meter Service

Dear Water Department Customer:

The authorization for use of Fire Hydrant Meter # _____ located at (Meter location address) ends in 60 days and will be removed on or after (Date authorization expires). Extension requests for an additional 90 days must be submitted in writing for consideration 30 days prior to the discontinuation date. If you require an extension, please refer to the Water Departments', Department Instruction (D.I.) 55.27 for further information and procedure.

Mail your request for an extension to :

City of San Diego, Water Department
Attn: Meter Services
2797 Caminito Chollas
San Diego, Ca. 92105-5097

Should you have any questions regarding this matter, please call the Fire Hydrant "Hot Line" at: (xxx) xxx-xxx.

Sincerely,

City of San Diego Water Department



Fire Hydrant Meter Relocate/Removal Request

(EXHIBIT D)

For Office Use Only

NS Req:	FHM Fac #:
Date:	By:

Date:

Instruction: Complete pertinent information then FAX both form and map to (xxx) xxx-xxxx, mail, or hand-deliver to the City of San Diego, Water Department/Meter Shop at: 2707 Caminito Chollas San Diego, CA 92105

Meter Information

Billing Account #:	Requested Move Date:
Current Fire Hydrant Meter Location:	
New Meter Location: (Attach a detailed map, Thomas Bros map location or construction drawing.)	

Company Information

Company Name:			
Mailing Address			
City:	State:	Zip Code:	Phone: ()
Name and Title of Requestor:			Phone: ()
Site Contact Name and Title			Phone: ()
Pager #:			Cell: ()
Responsible Party Name authorizing relocation fee:			
Signature:	Title:	Date:	

Fire Hydrant Meter Removal Request

<input type="checkbox"/> Check Box to Request Removal of Above Meter	Requested Removal Date:	
Provide current Meter location if different from above:		
Signature:	Title:	Date:
Phone: ()	Pager: ()	

For Office Use Only

CIS Account #:	Fees Amount: \$		
Meter Serial #:	Size:	Make/Style	
Backflow #:	Size:	Make/Style	
Name:	Signature:	Date:	

FHM Relocate_Removal Form

FHM App Created: 11/2/00-htp

APPENDIX C
SAMPLE CITY INVOICE

City of San Diego, Field Engineering Div., 9485 Aero Drive, SD CA 92123						Contractor's Name:					
Project Name:						Contractor's Address:					
SAP No. (WBS/IO/CC):											
City Purchase Order No. :						Contractor's Phone #:			Invoice No.		
Resident Engineer (RE):						Contractor's Fax #:			Invoice Date:		
RE Phone#:			RE Fax#:			Contact Name:			Billing Period:		
Item #	Item Description	Contract Authorization				Previous Estimate		This Estimate		Totals to Date	
		Unit	Qty	Price	Extension	%/QTY	Amount	% / QTY	Amount	% / QTY	Amount
1	2 Parallel 4" PVC C900	LF	1,380	\$34.00	\$46,920.00						
2	48" Primary Steel Casing	LF	500	\$1,000.00	\$500,000.00						
3	2 Parallel 12" Secondary Steel	LF	1,120	\$53.00	\$59,360.00						
4	Construction and Rehab of PS 49	LS	1	\$150,000.00	\$150,000.00						
5	Demo	LS	1	\$14,000.00	\$14,000.00						
6	Install 6' High Chain Link Fence	LS	1	\$5,600.00	\$5,600.00						
7	General Site Restoration	LS	1	\$3,700.00	\$3,700.00						
8	10" Gravity Sewer	LF	10	\$292.00	\$2,920.00						
9	4" Blow Off Valves	EA	2	\$9,800.00	\$19,600.00						
10	Bonds	LS	1	\$16,000.00	\$16,000.00						
11	Field Orders	AL	1	80,000	\$80,000.00						
11.1	Field Order 1	LS	5,500	\$1.00	\$5,500.00						
11.2	Field Order 2	LS	7,500	\$1.00	\$7,500.00						
11.3	Field Order 3	LS	10,000	\$1.00	\$10,000.00						
11.4	Field Order 4	LS	6,500	\$1.00	\$6,500.00						
12	Certified Payroll	LS	1	\$1,400.00	\$1,400.00						
CHANGE ORDERS											
Change Order 1			4,890								
Items 1-4					\$11,250.00						
Item 5-Deduct Bid Item 3		LF	120	-\$53.00	(\$6,360.00)						
Change Order 2			160,480								
Items 1-3					\$95,000.00						
Item 4 Deduct Bid Item 1		LF	380	-\$340.00	(\$12,920.00)						
Item 5-Encrease bid Item 9		LF	8	\$9,800.00	\$78,400.00						
Change Order 3 (Close Out)			-121,500								
Item 1 Deduct Bid Item 3			53	-500.00	(\$26,500.00)						
Item 2 Deduct Bid Item 4		LS	-1	45,000.00	(\$45,000.00)						
Items 3-9			1	-50,500.00	(\$50,500.00)						
SUMMARY								Total This	\$ -	Total Billed	\$0.00
A. Original Contract Amount						Retention and/or Escrow Payment Schedule					
B. Approved Change Order 1 Thru 3						Total Retention Required as of this billing					
C. Total Authorized Amount (A+B)						Previous Retention Withheld in PO or in Escrow					
D. Total Billed to Date						Add'l Amt to Withhold in PO/Transfer in Escrow:					
E. Less Total Retention (5% of D)						Amt to Release to Contractor from PO/Escrow:					
F. Less Total Previous Payments											
G. Payment Due Less Retention						Contractor Signature and Date:					
H. Remaining Authorized Amount											

APPENDIX D
LOCATION MAP

THIS MAP/DRAWING IS PROVIDED WITHOUT WARRANTY OF ANY KIND, EXPRESS OR IMPLIED, INCLUDING BUT NOT LIMITED TO, THE IMPLIED WARRANTIES OF MERCHANTABILITY AND FITNESS FOR A PARTICULAR PURPOSE. Note: This product may contain information reproduced with permission granted by RAND McNALLY & COMPANY to SANGIS. This map is copyrighted by RAND McNALLY & COMPANY. It is unlawful to copy or reproduce all or any part thereof, whether for personal use or resale, without the prior, written permission of RAND McNALLY & COMPANY.



PROJECT NAME

Kelton Road Pedestrian Improvement

SENIOR ENGINEER
 Brad Johnson
 619-533-5120

PROJECT MANAGER
 Louis Schultz
 619-533-4668

PROJECT ENGINEER
 Kileyesus Zaid
 619- 533 - 5251

PUBLIC INFORMATION OFFICER
 Pierrette Storey
 619-533-3781



Division Name - E&CP-ROWD

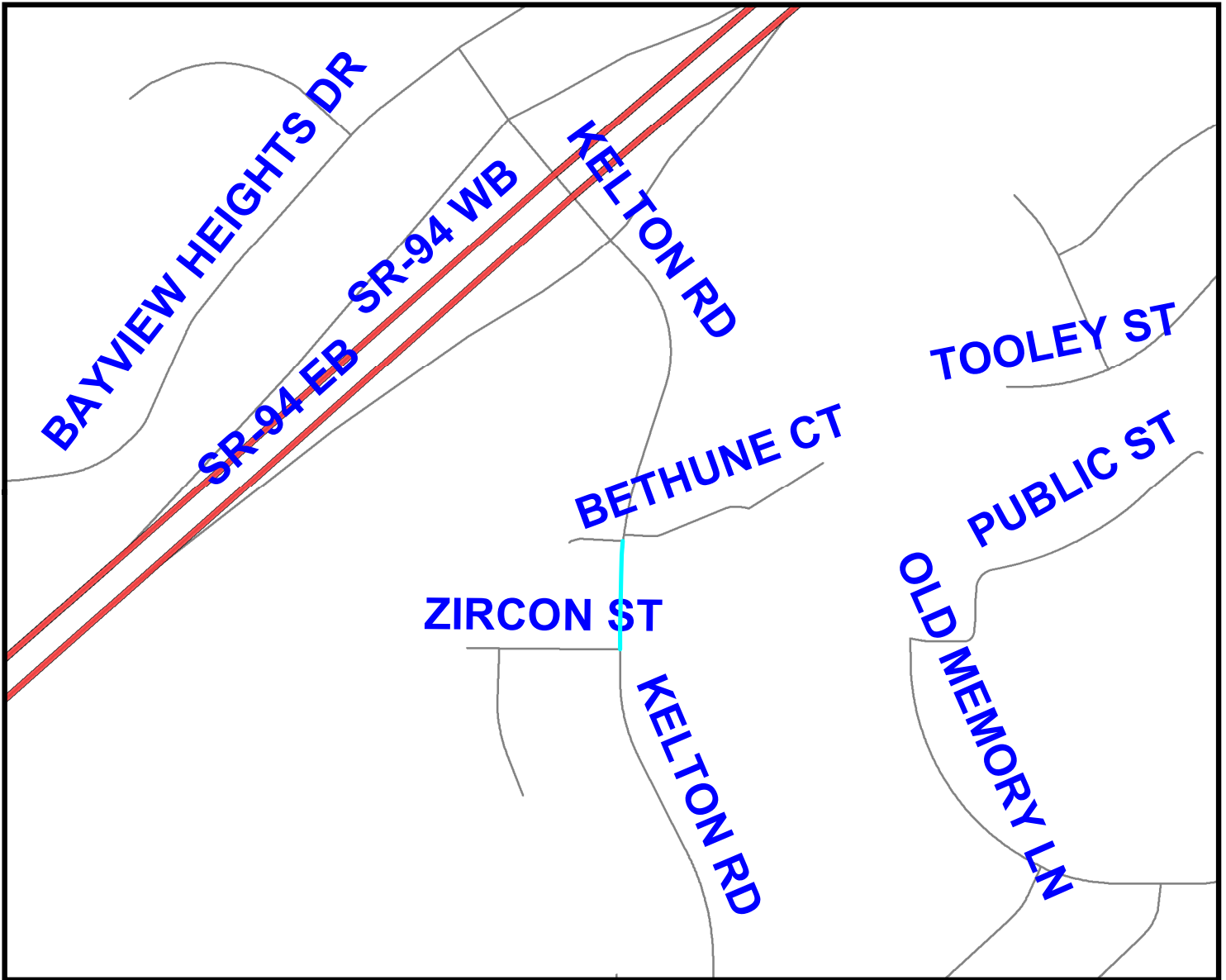

Legend

——— S10154 Kelton Road Pedestrian Improvement



No Scale

Appendix D – Location Map - Kelton Road Sidewalk Improvements

COMMUNITY NAME: ENCANTO, SE

COUNCIL DISTRICT: 04

SAP ID: S-10154

Date: February 16, 2010



APPENDIX E
CALTRANS GUARDRAIL STANDARDS

DIST	COUNTY	ROUTE	POST MILES TOTAL PROJECT	SHEET NO.	TOTAL SHEETS

Randell D. Hiatt
REGISTERED CIVIL ENGINEER

May 1, 2006
PLANS APPROVAL DATE

The State of California or its officers or agents shall not be responsible for the accuracy or completeness of electronic copies of this plan sheet.

To get to the Caltrans web site, go to: <http://www.dot.ca.gov>

REGISTERED PROFESSIONAL ENGINEER
Randell D. Hiatt
No. C50200
Exp. 6-30-07
CIVIL
STATE OF CALIFORNIA

2006 STANDARD PLAN A77A1

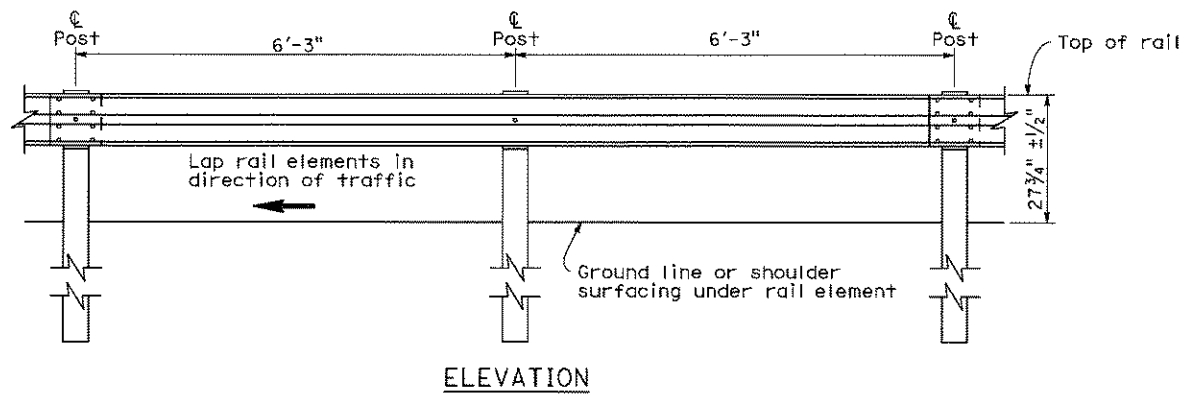
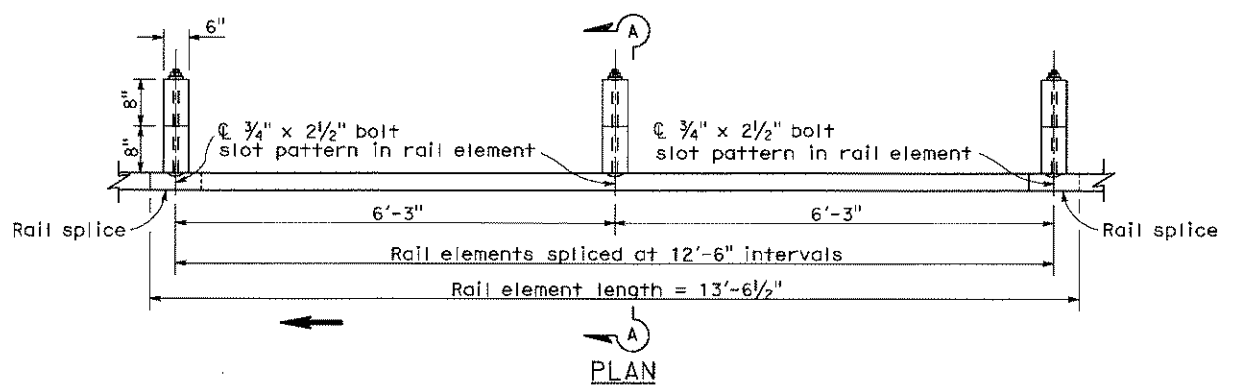

METAL BEAM GUARD RAILING WITH WOOD POST AND BLOCKS

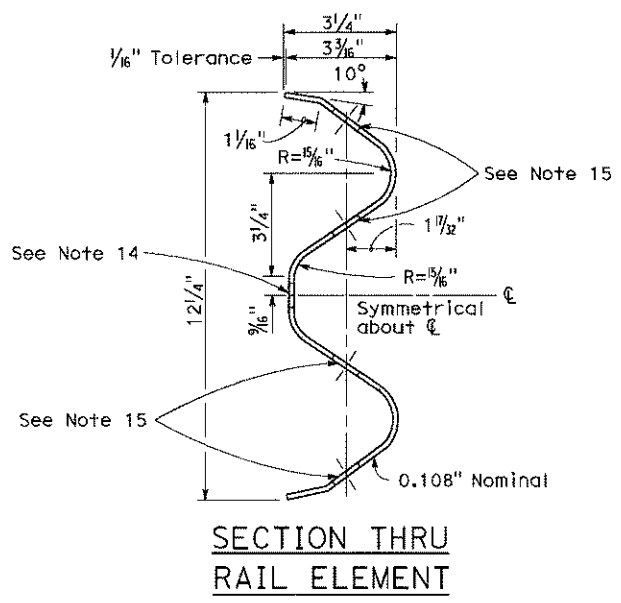

NOTES:

- For details of steel post installations, see Standard Plan A77A2.
- For details of standard hardware used to construct guard railing, see Standard Plan A77B1.
- For details of wood posts and wood blocks used to construct guard railing, see Standard Plan A77C1.
- For additional installation details, see Standard Plan A77C3.
- Guard railing post spacing to be 6'-3" center to center, except as otherwise noted.
- For guard railing typical layouts, see the A77E, A77F and A77G Series of Standard Plans.
- For terminal system end treatment details, see the A77L Series of Standard Plans.
- For guard railing end anchor details, see Standard Plans A77H1 and A77I2.
- For details of guard railing transition to bridge railing, see Standard Plan A77J4.
- For additional details of guard railing connection to bridge railings, see Standard Plans A77J1, A77J2 and A77K1.
- For guard railing connection details to abutments and walls, see Standard Plan A77J3.
- Direction of adjacent traffic indicated by →.
- For typical guard railing delineation and dike positioning details, see Standard Plan A77C4.
- Slotted hole for bolted connection of rail element to block and post. See "Section Thru Rail Element".
- Slotted holes for splice bolts to overlap ends of rail element. See "Section Thru Rail Element".
- Additional hole in uppermost portion of line post is for potential future adjustments of railing height. See Standard Plan A77C1.

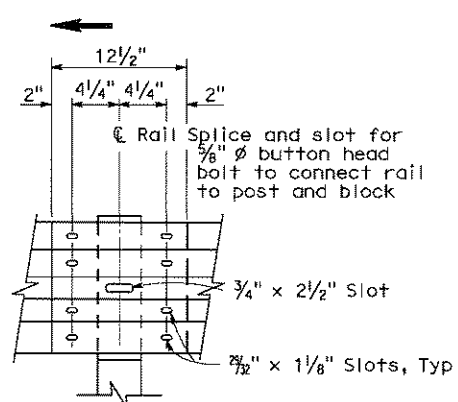

- Connect the overlapped end of the rail elements with 5/8" ϕ x 1 3/8" button head oval shoulder splice bolts inserted into the 3/4" x 1 1/8" slots and bolted together with 5/8" ϕ recessed hex nuts. Recess of hex nut points toward rail element. A total of 8 bolts and nuts are to be used at each rail splice connection.
- The ends of the rail elements are to be overlapped in the direction of traffic (see details).
- Where end cap is to be attached to the end of a rail element, a total of 4 of the above described splice bolts and nuts are to be used.

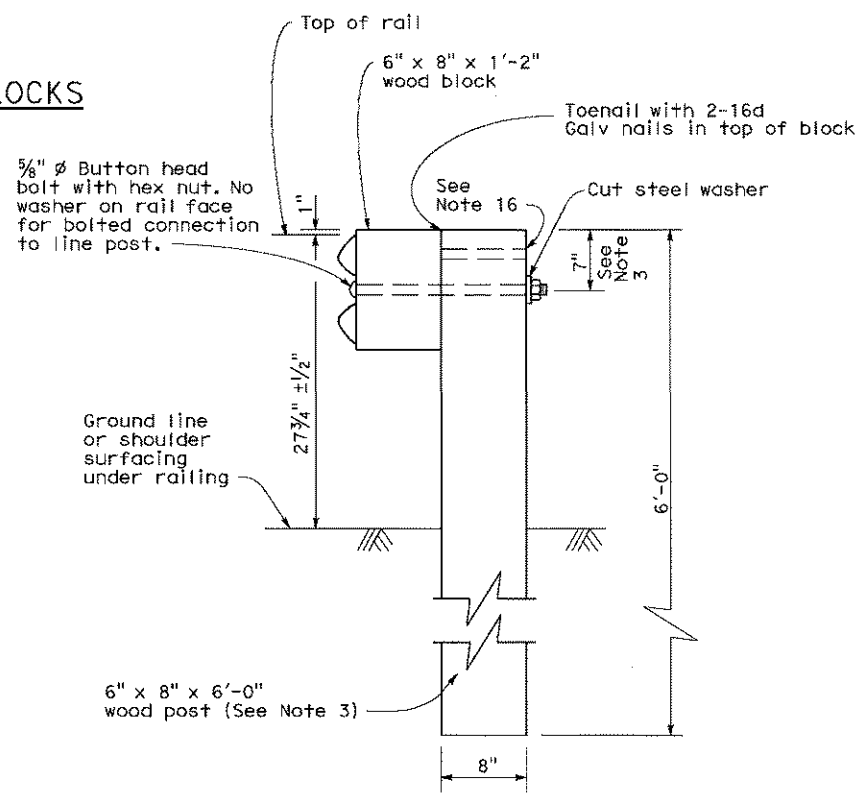

STATE OF CALIFORNIA
DEPARTMENT OF TRANSPORTATION

**METAL BEAM GUARD RAILING
STANDARD RAILING SECTION
(WOOD POST WITH
WOOD BLOCK)**

NO SCALE

A77A1

TABLE A
POST OFFSET DIMENSIONS

Post No.	3'-0" System End Offset	3'-6" System End Offset
1	36"	42"
2	22 1/4"	27 3/4"
3	11 3/4"	16 1/4"
4	6 3/4"	10 5/8"
5	3"	6"
6	0"	2 1/4"
7	0"	0"
8	0"	0"

See Note 12

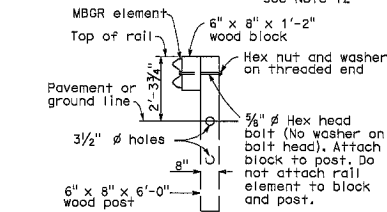

SECTION A-A

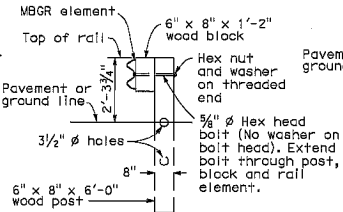

SECTION B-B

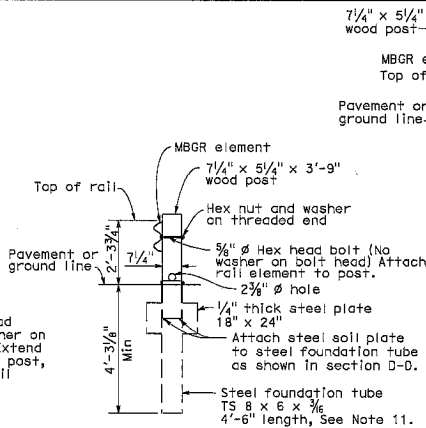

SECTION C-C

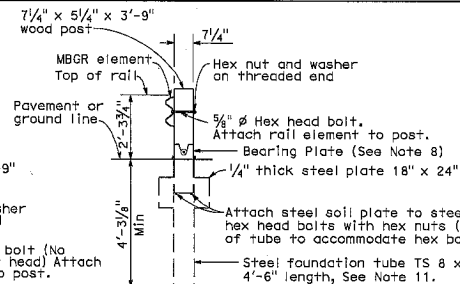

SECTION D-D
(Terminal Section not shown)

NOTES:

- For additional details of Terminal System (Type SRT), refer to the manufacturer's installation instructions.
- The post offset dimensions are given to the center of the traffic face of the block, except at the first two posts, where the dimension is to the center of the traffic face of the post. Offset points are to be located by chord measurements at the back of the rail equal to the nominal post spacings shown. Posts are to be set approximately radial to the railing at each post locations.
- Do not attach rail elements to posts 7 and 8.
- Attach strut to Post Nos. 1 and 2 foundation tubes with 5/8" diameter hex head bolts, washers and hex nuts. Bolts extend through the strut, steel foundation tube, and wood posts.
- For the length and type of metal beam guard railing or metal barrier railing the terminal system is attached to, see the Project Plans.
- Attach rail element to this post and block. Payment for this post, block and hardware is included in payment for the type of railing or barrier the terminal system is attached to, not part of payment for Terminal System (Type SRT).
- The deflector angle of the slot guard is to be positioned immediately downstream of the slots.
- For bearing plate orientation, refer to the manufacturer's installation instructions.
- For typical use of this terminal system with guard railing, see the A77E, A77F and A77G Series of Standard Plans. See Standard Plan A78E for typical use of this terminal system with single triple beam barrier.
- A complete wrap around end section may continue to be used in existing installations. New installations shall be constructed with the 3/4" wrap end section shown.
- A 6'-0" length steel foundation tube, TS 8 x 6 x 3/8, without a soil plate, may be furnished and installed in place of the 4'-6" length steel foundation tube and soil plate shown. Minimum embedment of the 6'-0" length tube shall be 5'-9". A 5/8" diameter hex head bolt and nut shall be installed in the hole in the 6'-0" length tube to keep the wood post from dropping into the tube.
- Where site conditions will not accommodate use of the standard 4'-0" system end offset, 3'-6" or 3'-0" system end offsets, as applicable, may be used. See Table A for post offset dimensions for 3'-6" and 3'-0" system end offsets.

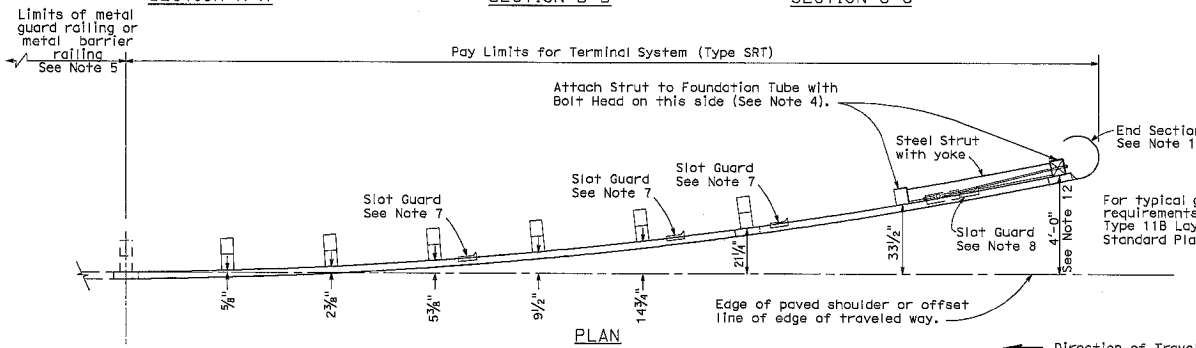

PLAN

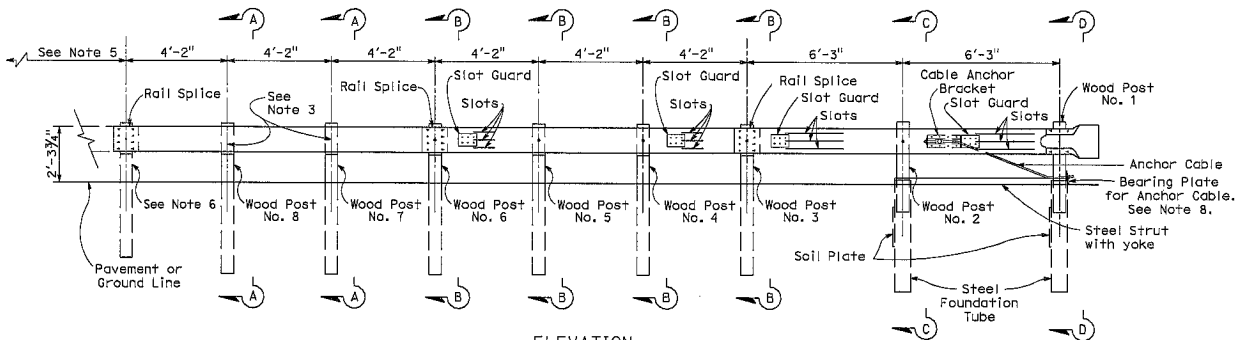

ELEVATION

TERMINAL SYSTEM (TYPE SRT)
(8 Post System)
See Note 9

DIST	COUNTY	ROUTE	POST MILES	SHEET NO.	TOTAL SHEETS

Randell D. Hiett
REGISTERED CIVIL ENGINEER

May 1, 2006
PLANS APPROVAL DATE

The State of California or its officers or agents shall not be responsible for the accuracy or completeness of electronic copies of this plan sheet.

To get to the Caltrans web site, go to: <http://www.fdot.ca.gov>

REGISTERED PROFESSIONAL ENGINEER
Randell D. Hiett
No. C50200
Exp. 6-30-07
CIVIL
STATE OF CALIFORNIA

STATE OF CALIFORNIA
DEPARTMENT OF TRANSPORTATION
**METAL BEAM RAILING
TERMINAL SYSTEM
(TYPE SRT)**

NO SCALE

A77L1

2006 STANDARD PLAN A77L1

Dist	COUNTY	ROUTE	POST MILES TOTAL PROJECT	SHEET No.	TOTAL SHEETS
Randell D. Hiett REGISTERED CIVIL ENGINEER					
May 20, 2011 PLANS APPROVAL DATE					
<small>The State of California or its officers or agents shall not be responsible for the accuracy or completeness of electronic copies of this plan sheet.</small>					
To accompany plans dated _____					

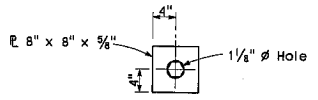
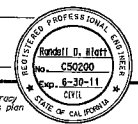

DETAIL A
CABLE CONNECTION
END PLATE

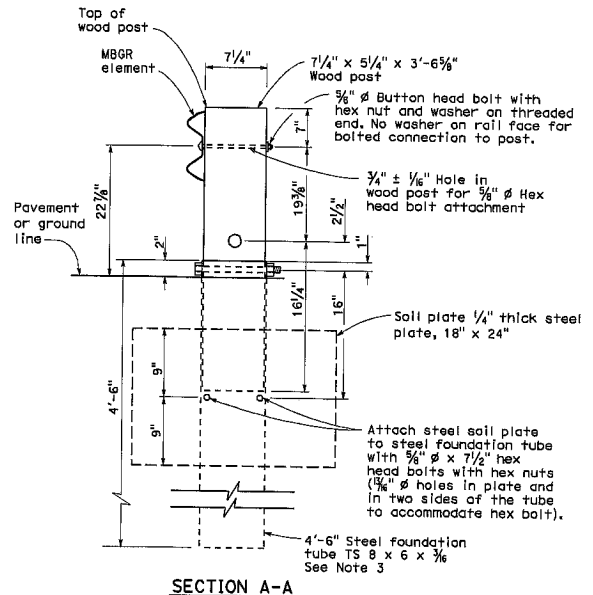

SECTION A-A

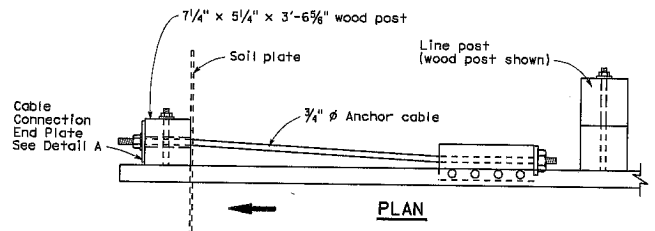

PLAN

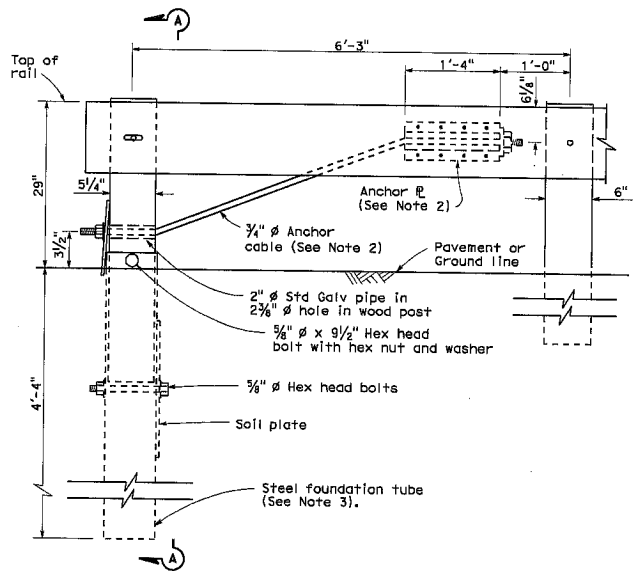

ELEVATION
END ANCHOR
ASSEMBLY (TYPE SFT)
See Note 1

NOTES:

1. See the A77E, A77F and A77G series of Standard Plans for typical use of End Anchor Assembly (Type SFT).
2. For details of the anchor plate and 3/4" cable, see Standard Plan A77H3.
3. A 6'-0" length steel foundation tube, TS 8 x 6 x 1/8, without a soil plate, may be furnished and installed in place of the 4'-6" length steel foundation tube and soil plate shown. Minimum embedment of the 6'-0" length tube shall be 5'-9". A 3/8" diameter hex head bolt and nut shall be installed in the 6'-0" length tube to keep the wood post from dropping into the tube.
4. Direction of traffic indicated by →.
5. Install line post, steel foundation tube and soil plate in soil.

STATE OF CALIFORNIA
DEPARTMENT OF TRANSPORTATION
METAL RAILING
END ANCHOR ASSEMBLY
(TYPE SFT)

NO SCALE

RSP A77H1 DATED MAY 20, 2011 SUPERSEDES STANDARD PLAN A77H1
DATED MAY 1, 2006 - PAGE 67 OF THE STANDARD PLANS BOOK DATED MAY 2006.

REVISED STANDARD PLAN RSP A77H1

2006 REVISED STANDARD PLAN RSP A77H1

APPENDIX F
ADJACENT PROJECTS

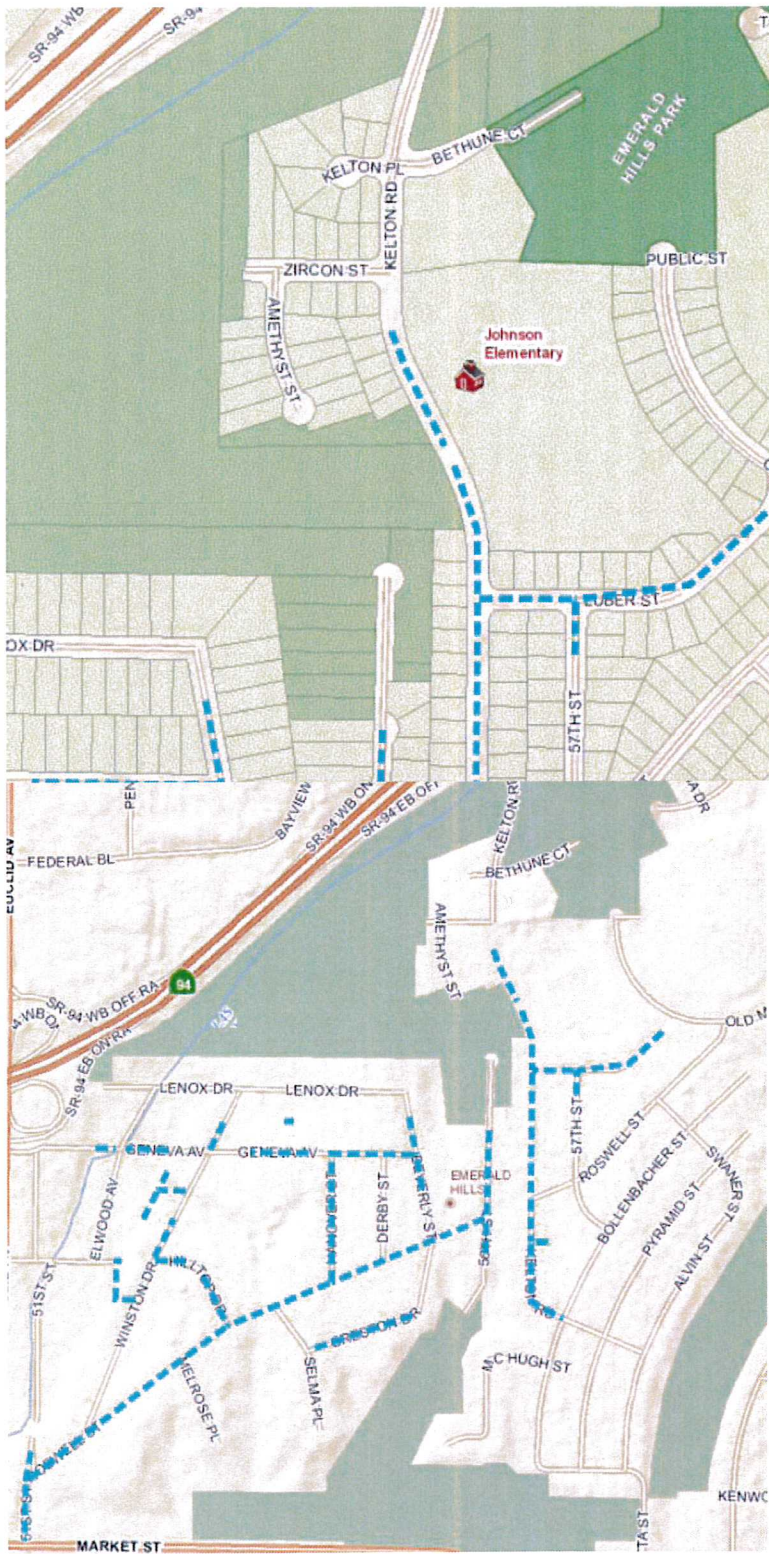

Potential Conflict: B11074 – Pipeline Rehabilitation – Q1 and Kelton Road – Pedestrian Improvements (between Zircon Street & Luber Street West of Johnson Elementary School)

City of San Diego

CITY CONTACT: Damian Singleton, Contract Specialist, Email: dsingleton@sandiego.gov
Phone No. (619) 533-3482, Fax No. (619) 533-3633



ADDENDUM “A”

FOR

KELTON ROAD SIDEWALK IMPROVEMENTS

BID NO.:	<u>L-13-5607-DBB-1-A</u>
SAP NO. (WBS/IO/CC):	<u>S-10154</u>
CLIENT DEPARTMENT:	<u>2116</u>
COUNCIL DISTRICT:	<u>4</u>
PROJECT TYPE:	<u>IK</u>

BID DUE DATE:

**1:30 PM
MAY 8, 2013
CITY OF SAN DIEGO
PUBLIC WORKS DEPARTMENT
1010 SECOND AVENUE, SUITE 1400, MS 614C
SAN DIEGO, CA 92101**

ENGINEER OF WORK

The engineering Specifications and Special Provisions contained herein have been prepared by or under the direction of the following Registered Engineer

Brad Johnson
For City Engineer

4/17/13
Date

Seal:



A. CHANGES TO CONTRACT DOCUMENTS

The following changes to the Contract Documents are hereby made effective as though originally issued with the bid package. Bidders are reminded that all previous requirements to this solicitation remain in full force and effect.

B. VOLUME 1

1. To Volume 1 and Volume 2 cover page, **DELETE** in their entirety and **SUBSTITUTE** with page 4 of 5 through 5 of 5 of this Addendum.
2. To the Supplementary Special Provisions (SSP), SECTION 2, "SCOPE AND CONTROL OF WORK," Subsection 2-3.2, "Self Performance," Item 1, page 30, **DELETE** in its entirety and **SUBSTITUTE** with the following:
 1. You must perform, with your own organization, Contract work amounting to at least 40% of the base bid alone or base bid and any additive or deductive alternate(s) that together when added or deducted form the basis of award.

Tony Heinrichs, Director
Public Works Department

Dated: April 18, 2013
San Diego, California

TH/ds/ar/lr

City of San Diego

CONTRACTOR'S NAME: _____
ADDRESS: _____
TELEPHONE NO.: _____ FAX NO.: _____
CITY CONTACT: DAMIAN SINGLETON, Contract Specialist, Email: dsingleton@sandiego.gov
Phone No. (619) 533-3482, Fax No. (619) 533-3633
L SCHULTZ / A REYES / LS



CONTRACT DOCUMENTS

FOR

KELTON ROAD SIDEWALK IMPROVEMENTS

VOLUME 1 OF 2

BID NO.:	<u>L-13-5607-DBB-1-A</u>
SAP NO. (WBS/IO/CC):	<u>S-10154</u>
CLIENT DEPARTMENT:	<u>2116</u>
COUNCIL DISTRICT:	<u>4</u>
PROJECT TYPE:	<u>IK</u>

THIS CONTRACT IS SUBJECT TO THE FOLLOWING:

- THE CITY'S SUBCONTRACTING PARTICIPATION REQUIREMENTS FOR SLBE PROGRAM.
- COMPETITION RESTRICTED TO: ELBE

BID DUE DATE:

**1:30 PM
MAY 8, 2013
CITY OF SAN DIEGO
PUBLIC WORKS DEPARTMENT
1010 SECOND AVENUE, SUITE 1400, MS 614C
SAN DIEGO, CA 92101**

City of San Diego

CONTRACTOR'S NAME: _____
ADDRESS: _____
TELEPHONE NO.: _____ FAX NO.: _____
CITY CONTACT: DAMIAN SINGLETON, Contract Specialist, Email: dsingleton@sandiego.gov
Phone No. (619) 533-3482, Fax No. (619) 533-3633
L SCHULTZ / A REYES / LS



CONTRACT DOCUMENTS

FOR

KELTON ROAD SIDEWALK IMPROVEMENTS

VOLUME 2 OF 2

BID NO.: L-13-5607-DBB-1-A
SAP NO. (WBS/IO/CC): S-10154
CLIENT DEPARTMENT: 2116
COUNCIL DISTRICT: 4
PROJECT TYPE: IK

THIS CONTRACT IS SUBJECT TO THE FOLLOWING:

- THE CITY'S SUBCONTRACTING PARTICIPATION REQUIREMENTS FOR SLBE PROGRAM.
- COMPETITION RESTRICTED TO: ELBE

THIS BIDDING DOCUMENT TO BE SUBMITTED IN ITS ENTIRETY
REFER TO VOLUME 1 COVER PAGE FOR TIME, DATE, AND LOCATION

City of San Diego

CONTRACTOR'S NAME: HTA ENGINEERING & CONSTRUCTION, INC.
ADDRESS: 5450 COMPLEX STREET, SUITE 303, SAN DIEGO, CA 92123
TELEPHONE NO.: 858-598-6855 FAX NO.: 858-836-1263
CITY CONTACT: DAMIAN SINGLETON, Contract Specialist, Email: dsingleton@sandiego.gov
Phone No. (619) 533-3482, Fax No. (619) 533-3633
L SCHULTZ / A REYES / LS



CONTRACT DOCUMENTS

FOR

KELTON ROAD SIDEWALK IMPROVEMENTS

VOLUME 2 OF 2

BID NO.:	<u>L-13-5607-DBB-1-A</u>
SAP NO. (WBS/IO/CC):	<u>S-10154</u>
CLIENT DEPARTMENT:	<u>2116</u>
COUNCIL DISTRICT:	<u>4</u>
PROJECT TYPE:	<u>IK</u>

THIS CONTRACT IS SUBJECT TO THE FOLLOWING:

- THE CITY'S SUBCONTRACTING PARTICIPATION REQUIREMENTS FOR SLBE PROGRAM.
- COMPETITION RESTRICTED TO: ELBE

**THIS BIDDING DOCUMENT TO BE SUBMITTED IN ITS ENTIRETY
REFER TO VOLUME 1 COVER PAGE FOR TIME, DATE, AND LOCATION**

TABLE OF CONTENTS

Volume 2 - Bidding Documents

The following forms must be completed in their entirety and submitted with the Bid. Include the form(s) even if the information does not apply. Where the information does not apply write in N/A. Failure to include any of the forms may cause the Bid to be deemed **non-responsive**. If you are uncertain or have any questions about any required information, contact the City no later than 14 days prior to Bid due date.

1. Bid/Proposal.....	3-6
2. Non-Collusion Affidavit to be executed by Bidder and Submitted with Bid under 23 USC 112 and PCC 7106	7
3. Contractors Certification of Pending Actions.....	8
4. Equal Benefits Ordinance Certification of Compliance.....	9
5. Proposal (Bid).....	10-13
6. Form AA35 - List of Subcontractors	14
7. Form AA40 - Named Equipment/Material Supplier List	15

BIDDING DOCUMENTS

PROPOSAL

Bidder's General Information

To the City of San Diego:

Pursuant to "Notice Inviting Bids", specifications, and requirements on file with the City Clerk, and subject to all provisions of the Charter and Ordinances of the City of San Diego and applicable laws and regulations of the United States and the State of California, the undersigned hereby proposes to furnish to the City of San Diego, complete at the prices stated herein, the items or services hereinafter mentioned. The undersigned further warrants that this bid is not made in the interest of, or on behalf of, any undisclosed person, partnership, company, association, organization, or corporation; that the bid is genuine and not collusive or sham; that the bidder has not directly or indirectly induced or solicited any other bidder to put in a false or sham bid, and has not directly or indirectly colluded, conspired, connived, or agreed with any bidder or anyone else to put in a sham bid, or that anyone shall refrain from bidding; that the bidder has not in any manner, directly or indirectly, sought by agreement, communication, or conference with anyone to fix the bid price of the bidder or any other bidder, or to fix any overhead, profit, or cost element of the bid price, or of that of any other bidder, or to secure any advantage against the public body awarding the contract of anyone interested in the proposed contract; that all statements contained in the bid are true; and, further, that the bidder has not, directly or indirectly, submitted his or her bid price or any breakdown thereof, or the contents thereof, or divulged information or data relative thereto, or paid, and will not pay, any fee to any corporation, partnership, company, association, organization, bid depository, or to any member or agent thereof to effectuate a collusive or sham bid.

The undersigned bidder(s) further warrants that bidder(s) has thoroughly examined and understands the entire Contract Documents (plans and specifications) and the Bidding Documents therefore, and that by submitting said Bidding Documents as its bid proposal, bidder(s) acknowledges and is bound by the entire Contract Documents, including any addenda issued thereto, as such Contract Documents incorporated by reference in the Bidding Documents.

IF A SOLE OWNER OR SOLE CONTRACTOR SIGN HERE:

- (1) Name under which business is conducted _____
- (2) Signature (Given and surname) of proprietor _____
- (3) Place of Business (Street & Number) _____
- (4) City and State _____ Zip Code _____
- (5) Telephone No. _____ Facsimile No. _____

BIDDING DOCUMENTS

IF A PARTNERSHIP, SIGN HERE:

- (1) Name under which business is conducted _____
- (2) Name of each member of partnership, indicate character of each partner, general or special (limited):

- (3) Signature (Note: Signature must be made by a general partner)

Full Name and Character of partner

- (4) Place of Business (Street & Number) _____
- (5) City and State _____ Zip Code _____
- (6) Telephone No. _____ Facsimile No. _____

IF A CORPORATION, SIGN HERE:

- (1) Name under which business is conducted HTA ENGINEERING & CONSTRUCTION, INC.
- (2) Signature, with official title of officer authorized to sign for the corporation:
Hatim T. Askar
(Signature)
HATIM T. ASKAR
(Printed Name)
PRESIDENT
(Title of Officer)

(Impress Corporate Seal Here)
- (3) Incorporated under the laws of the State of CALIFORNIA
- (4) Place of Business (Street & Number) 5450 COMPLEX STREET, SUITE 303
- (5) City and State SAN DIEGO, CALIFORNIA Zip Code 92123
- (6) Telephone No. 858-598-0855 Facsimile No. 858-836-1263

BIDDING DOCUMENTS

THE FOLLOWING SECTIONS MUST BE FILLED IN BY ALL PROPOSERS:

In accordance with the "NOTICE INVITING BIDS", the bidder holds a California State Contractor's license for the following classification(s) to perform the work described in these specifications:

LICENSE CLASSIFICATION ~~748372~~ A 911A

LICENSE NO. 798372 EXPIRES JULY 31, 2014

This license classification must also be shown on the front of the bid envelope. Failure to show license classification on the bid envelope may cause return of the bid unopened.

TAX IDENTIFICATION NUMBER (TIN): 61-1403228

E-Mail Address: Tim@htaeng.com

BIDDING DOCUMENTS

THIS PROPOSAL MUST BE NOTARIZED BELOW:

I certify, under penalty of perjury, that the representations made herein regarding my State Contractor's license number, classification and expiration date are true and correct.

Signature Halim T. Askan Title President

SUBSCRIBED AND SWORN TO BEFORE ME, THIS 06 DAY OF May, 2013

Notary Public in and for the County of _____, State of _____

(NOTARIAL SEAL)

CALIFORNIA ALL-PURPOSE ACKNOWLEDGMENT

STATE OF CALIFORNIA

County of SAN DIEGO

On 05/06/13 before me, BEVERLEY J. CROSS, NOTARY PUBLIC
Date Here Insert Name and Title of the Officer

personally appeared HATIM T. ASKAR
Name(s) of Signer(s)

who proved to me on the basis of satisfactory evidence to be the person(s) whose name(s) is/are subscribed to the within instrument and acknowledged to me that he/she/they executed the same in his/her/their authorized capacity(ies), and that by his/her/their signature(s) on the instrument the person(s), or the entity upon behalf of which the person(s) acted, executed the instrument.

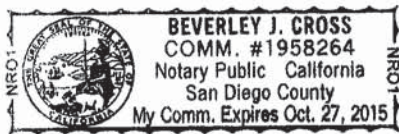

Place Notary Seal Above

I certify under PENALTY OF PERJURY under the laws of the State of California that the foregoing paragraph is true and correct.

Witness my hand and official seal.

Signature

Signature of Notary Public

OPTIONAL

Though the information below is not required by law, it may prove valuable to persons relying on the document and could prevent fraudulent removal and reattachment of this form to another document.

Description of Attached Document

Title or Type of Document: Bid Doc.

Document Date: 05/06/13 Number of Pages: 1

Signer(s) Other Than Named Above: _____

Capacity(ies) Claimed by Signer(s)

Signer's Name: HATIM T. ASKAR

- Individual
- Corporate Officer — Title(s): PRESIDENT
- Partner — Limited General
- Attorney in Fact
- Trustee
- Guardian or Conservator
- Other: _____

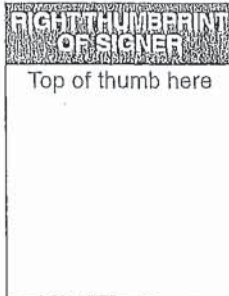

Signer Is Representing: _____

Signer's Name: _____

- Individual
- Corporate Officer — Title(s): _____
- Partner — Limited General
- Attorney in Fact
- Trustee
- Guardian or Conservator
- Other: _____

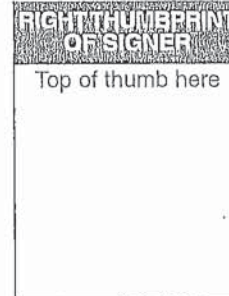

Signer Is Representing: _____

BIDDING DOCUMENTS

NON-COLLUSION AFFIDAVIT TO BE EXECUTED BY BIDDER AND SUBMITTED WITH BID UNDER 23 UNITED STATES CODE 112 AND PUBLIC CONTRACT CODE 7106

State of California)
County of SAN DIEGO) ss.

HATIM T. ASKAR, being first duly sworn, deposes and says that he or she is PRESIDENT of the party making the foregoing bid that the bid is not made in the interest of, or on behalf of, any undisclosed person, partnership, company, association, organization, or corporation; that the bid is genuine and not collusive or sham; that the bidder has not directly or indirectly induced or solicited any other bidder to put in a false or sham bid, and has not directly or indirectly colluded, conspired, connived, or agreed with any bidder or anyone else to put in a sham bid, or that anyone shall refrain from bidding; that the bidder has not in any manner, directly or indirectly, sought by agreement, communication, or conference with anyone to fix the bid price of the bidder or any other bidder, or to fix any overhead, profit, or cost element of the bid price, or of that of any other bidder, or to secure any advantage against the public body awarding the contract of anyone interested in the proposed contract; that all statements contained in the bid are true; and further, that the bidder has not, directly or indirectly, submitted his or her bid price or any breakdown thereof, or the contents thereof, or divulged information or data relative thereto, or paid, and will not pay, any fee to any corporation, partnership, company association, organization, bid depository, or to any member or agent thereof to effectuate a collusive or sham bid.

Signed: Hatim T. Askar

Title: PRESIDENT

Subscribed and sworn to before me this 6 day of May, 2013

Notary Public

(SEAL)

CALIFORNIA ALL-PURPOSE ACKNOWLEDGMENT

STATE OF CALIFORNIA

County of SAN DIEGO

On 05/06/13 before me, BEVERLEY J. CROSS, NOTARY PUBLIC
Date Here Insert Name and Title of the Officer

personally appeared HATIM T. ASKAR
Name(s) of Signer(s)

who proved to me on the basis of satisfactory evidence to be the person(s) whose name(s) is/are subscribed to the within instrument and acknowledged to me that he/she/they executed the same in his/her/their authorized capacity(ies), and that by his/her/their signature(s) on the instrument the person(s), or the entity upon behalf of which the person(s) acted, executed the instrument.

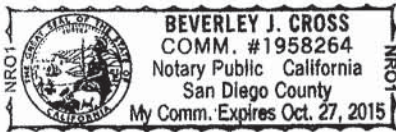

Place Notary Seal Above

I certify under PENALTY OF PERJURY under the laws of the State of California that the foregoing paragraph is true and correct.

Witness my hand and official seal.

Signature [Handwritten Signature]
Signature of Notary Public

OPTIONAL

Though the information below is not required by law, it may prove valuable to persons relying on the document and could prevent fraudulent removal and reattachment of this form to another document.

Description of Attached Document

Title or Type of Document: Non-Collision Affidavit - Bid Doc

Document Date: 05/06/13 Number of Pages: 1

Signer(s) Other Than Named Above: _____

Capacity(ies) Claimed by Signer(s)

Signer's Name: HATIM T. ASKAR

- Individual
- Corporate Officer — Title(s): PRESIDENT
- Partner — Limited General
- Attorney in Fact
- Trustee
- Guardian or Conservator
- Other: _____

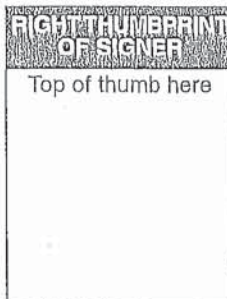

Signer Is Representing: _____

Signer's Name: _____

- Individual
- Corporate Officer — Title(s): _____
- Partner — Limited General
- Attorney in Fact
- Trustee
- Guardian or Conservator
- Other: _____



Signer Is Representing: _____

BIDDING DOCUMENTS

CONTRACTORS CERTIFICATION OF PENDING ACTIONS

As part of its bid or proposal (Non-Price Proposal in the case of Design-Build contracts), the Bidder shall provide to the City a list of all instances within the past ten years where a complaint was filed or pending against the Bidder in a legal or administrative proceeding alleging that Bidder discriminated against its employees, subcontractors, vendors or suppliers, and a description of the status or resolution of that complaint, including any remedial action taken.

CHECK ONE BOX ONLY.

- The undersigned certifies that within the past 10 years the Bidder has NOT been the subject of a complaint or pending action in a legal administrative proceeding alleging that Bidder discriminated against its employees, subcontractors, vendors or suppliers.
- The undersigned certifies that within the past 10 years the Bidder has been the subject of a complaint or pending action in a legal administrative proceeding alleging that Bidder discriminated against its employees, subcontractors, vendors or suppliers. A description of the status or resolution of that complaint, including any remedial action taken and the applicable dates is as follows:

DATE OF CLAIM	LOCATION	DESCRIPTION OF CLAIM	LITIGATION (Y/N)	STATUS	RESOLUTION/REMEDIAL ACTION TAKEN

Contractor Name: HTA ENGINEERING & CONSTRUCTION, INC.

Certified By HATIM ASKAR Title PRESIDENT
Name

Hatim Askar Date 5/8/2013
Signature

USE ADDITIONAL FORMS AS NECESSARY

BIDDING DOCUMENTS

**EQUAL BENEFITS ORDINANCE
CERTIFICATION OF COMPLIANCE**



For additional information, contact:
CITY OF SAN DIEGO
EQUAL BENEFITS PROGRAM
 202 C Street, MS 9A, San Diego, CA 92101
 Phone (619) 533-3948 Fax (619) 533-3220

COMPANY INFORMATION

Company Name: HTA ENGINEERING & CONSTRUCTION, INC.	Contact Name: TIM ASKAR
Company Address: 5450 COMPLEX STREET, SUITE 303	Contact Phone: 858-598-6855
SAN DIEGO, CA 92123	Contact Email: Tim@htaeng.com

CONTRACT INFORMATION

Contract Title: KELTON ROAD SIDEWALK IMPROVEMENTS	Start Date:
Contract Number (if no number, state location): L-13-5607-DB0-1-A	End Date:

SUMMARY OF EQUAL BENEFITS ORDINANCE REQUIREMENTS

The Equal Benefits Ordinance [EBO] requires the City to enter into contracts only with contractors who certify they will provide and maintain equal benefits as defined in SDMC §22.4302 for the duration of the contract. To comply:

- Contractor shall offer equal benefits to employees with spouses and employees with domestic partners.
 - Benefits include health, dental, vision insurance; pension/401(k) plans; bereavement, family, parental leave; discounts, child care; travel/relocation expenses; employee assistance programs; credit union membership; or any other benefit.
 - Any benefit not offer an employee with a spouse, is not required to be offered to an employee with a domestic partner.
- Contractor shall post notice of firm's equal benefits policy in the workplace and notify employees at time of hire and during open enrollment periods.
- Contractor shall allow City access to records, when requested, to confirm compliance with EBO requirements.
- Contractor shall submit *EBO Certification of Compliance*, signed under penalty of perjury, prior to award of contract.

NOTE: This summary is provided for convenience. Full text of the EBO and Rules Implementing the EBO are available at www.sandiego.gov/administration.

CONTRACTOR EQUAL BENEFITS ORDINANCE CERTIFICATION

Please indicate your firm's compliance status with the EBO. The City may request supporting documentation.

- I affirm **compliance** with the EBO because my firm (*contractor must select one reason*):
- Provides equal benefits to spouses and domestic partners.
 - Provides no benefits to spouses or domestic partners.
 - Has no employees.
 - Has collective bargaining agreement(s) in place prior to January 1, 2011, that has not been renewed or expired.
- I request the City's approval to pay affected employees a cash equivalent in lieu of equal benefits and verify my firm made a reasonable effort but is not able to provide equal benefits upon contract award. I agree to notify employees of the availability of a cash equivalent for benefits available to spouses but not domestic partners and to continue to make every reasonable effort to extend all available benefits to domestic partners.

It is unlawful for any contractor to knowingly submit any false information to the City regarding equal benefits or cash equivalent associated with the execution, award, amendment, or administration of any contract. [San Diego Municipal Code §22.4307(a)]

Under penalty of perjury under laws of the State of California, I certify the above information is true and correct. I further certify that my firm understands the requirements of the Equal Benefits Ordinance and will provide and maintain equal benefits for the duration of the contract or pay a cash equivalent if authorized by the City.

HATIM ASKAR / PRESIDENT

Hatim Askar

5/8/2013

Name/Title of Signatory

Signature

Date

FOR OFFICIAL CITY USE ONLY

Receipt Date: _____ EBO Analyst: _____ Approved Not Approved -- Reason: _____

(Rev 02/15/2011)

BIDDING DOCUMENTS

PROPOSAL (BID)

The Bidder agrees to the construction of **KELTON ROAD SIDEWALK IMPROVEMENTS**, for the city of San Diego, in accordance with these contract documents for the prices listed below. The Bidder guarantees the Contract Price for a period of 120 days (90 days for Contracts valued at \$500,000 or less) from the date of Bid opening to Award of the Contract. The duration of the Contract Price guarantee shall be extended by the number of days required for the City to obtain all items necessary to fulfill all conditions precedent e.g., bond and insurance.

Item	Quantity	Unit	Payment Reference	NAICS	Description	Unit Price	Extension
1	1	LS	2-4.1	237310	Bond (Payment and Performance)		\$ 3,000
2	1	LS	7-10.2.6	237310	Traffic Control Design		\$ 300
3	1	LS	7-10.2.6	541330	Traffic Control		\$ 1,000
4	1	LS	9-3.1	237310	Furnish and Install 10 Marker Lighted Crosswalk System		\$ 32,368
5	2	EA	9-3.1	237110	Furnish and Install W16-7p Sign	\$ 121	\$ 242
6	1	AL	9-3.5		Field Order Type II		\$10,000.00
7	1	LS	300-1.4	238910	Clearing & Grubbing		\$ 4,000
8	15	CY	300-2.9	237310	Excavate and Export (Unclassified)	\$ 100	\$ 1,500
9	9	CY	300-4.9	237310	Excavate and Fill (Unclassified)	\$ 100	\$ 900
10	240	SF	302-5.9	237310	2" AC over 7" of PCC (3250 psi)	\$ 11	\$ 2,640
11	4	TON	302-5.9	237310	AC Slope Repair	\$ 633	\$ 2,532
12	175	LF	303-5.9	237310	Curb & Gutter (6-Inch Curb, Type G)	\$ 35	\$ 6,125
13	46	LF	303-5.9	237310	Grade Beam with Integrated Chain Link Fence	\$ 135	\$ 6,210
14	1750	SF	303-5.9	237310	4" PCC Sidewalk	\$ 5.50	\$ 9,625
15	2	EA	303-5.10.2	237310	Curb Ramps Type B W/ Composite Detectable Warning	\$ 2,500	\$ 5,000
16	40	LF	304-1.12	238990	Repair Existing Fence	\$ 64	\$ 2,560

BIDDING DOCUMENTS

Item	Quantity	Unit	Payment Reference	NAICS	Description	Unit Price	Extension
17	60	LF	304-2.2.3	237310	Metal Beam Guardrail per A77A1 (per Appendix E) with End Anchor Assembly per A77H1 (per Appendix E)	\$ 61	\$ 3,660
18	40	LF	304-2.2.3	237310	Metal Railing Terminal System per A77L1 (per Appendix E)	\$ 80	\$ 3,200
19	1	LS	304-5	237310	Signing	 	
20	2	EA	307-2	238210	Furnish and Install Type 1-A Pole and Foundation	\$ 1,925	\$ 3,850
21	238	LF	307-2	238210	Furnish and Install 2" Electrical Conduit	\$ 20	\$ 4,760
22	166	LF	307-2	238210	Furnish and Install #10 Conductor	\$ 2.50	\$ 415
23	72	LF	307-2	238210	Furnish and Install 7 Conductor Cable	\$ 2.50	\$ 180
24	4	EA	307-2	238210	Furnish and Install #5 Pullbox	\$ 473	\$ 1,892
25	1	EA	307-2	238210	Furnish and Install Type III Electric Service (Meter Pedestal and 3" Conduit per SDGE Service Order)	\$ 4,741	\$ 4,741
26	125	LF	314-4.3.7	237310	Striping and Pavement Markings	\$ 16	\$ 2,000
27	1	LS	701-13.9.5	541330	Water Pollution Control Plan Development	 	
28	1	LS	701-13.9.5	237990	Water Pollution Control Program Implementation	 	
ESTIMATED TOTAL BASE BID							\$ 113,800

TOTAL BID PRICE FOR BID (Items 1 through 28 inclusive) amount written in words:

ONE HUNDRED THIRTEEN THOUSAND EIGHT HUNDRED DOLLARS

BIDDING DOCUMENTS

The Bid shall contain an acknowledgment of receipt of all addenda, the numbers of which shall be filled in on the Bid form. If an addendum or addenda has been issued by the City and not noted as being received by the Bidder, this proposal shall be rejected as being **non-responsive**. The following addenda have been received and are acknowledged in this bid: A

The names of all persons interested in the foregoing proposal as principals are as follows:

HITA ENGINEERING & CONSTRUCTION, INC.

HATIM T. ASKAR

IMPORTANT NOTICE: If Bidder or other interested person is a corporation, state secretary, treasurer, and manager thereof; if a co-partnership, state true name of firm, also names of all individual co-partners composing firm; if Bidder or other interested person is an individual, state first and last names in full.

Bidder: HITA ENGINEERING & CONSTRUCTION, INC.

Title: PRESIDENT

Business Address: 5450 COMPLEX STREET, SUITE 303, SAN DIEGO, CA 92123

Place of Business: 5450 COMPLEX STREET, SUITE 303, SAN DIEGO, CA 92123

Place of Residence: —

Signature: *Hatim Askar*

BIDDING DOCUMENTS

NOTES:

- A. The low City shall determine the low Bid based on the Base Bid alone.
- B. Prices and notations shall be in ink or typewritten. All corrections (which have been initiated by the Bidder using erasures, strike out, line out, or "white-out") shall be typed or written in with ink adjacent thereto, and shall be initialed in ink by the person signing the bid proposal.
- C. Failure to initial all corrections made in the bidding documents shall cause the Bid to be rejected as **non-responsive** and ineligible for further consideration.
- D. Blank spaces must be filled in, using figures. Bidder's failure to submit a price for any Bid item that requires the Bidder to submit a price shall render the Bid **non-responsive** and shall be cause for its rejection.
- E. Unit prices shall be entered for all unit price items. Unit prices shall not exceed two (2) decimal places. If the Unit prices entered exceed two (2) decimal places, the City will only use the first two digits after the decimal points without rounding up or down.
- F. All extensions of the unit prices bid will be subject to verification by the City. In the case of inconsistency or conflict between the product of the Quantity x Unit Price and the Extension, the product shall govern.
- G. In the case of inconsistency or conflict, between the sums of the Extensions with the estimated total Bid, the sum of the Extensions shall govern.
- H. Bids shall not contain any recapitulation of the Work. Conditional Bids will be rejected as being **non-responsive**. Alternative proposals will not be considered unless called for.

BIDDING DOCUMENTS

LIST OF SUBCONTRACTORS

In accordance with the requirements provided in the "Subletting and Subcontracting Fair Practices Act", Division 2, Part 1, Chapter 4 of the Public Contract Code, the Bidder shall list below the name and address of each Subcontractor who will perform work, labor, render services or specially fabricates and installs a portion [type] of the work or improvement, in an amount in excess of 0.5% of the Contractor's total Bid. The Bidder shall also list below the portion of the work which will be done by each subcontractor under this Contract. The Contractor shall list only one Subcontractor for each portion of the Work. The DOLLAR VALUE of the total Bid to be performed shall be stated for all subcontractors listed. Failure to comply with this requirement shall result in the Bid being rejected as non-responsive and ineligible for award. The Bidder's attention is directed to the Special Provisions - General; Paragraph 2-3 Subcontracts, which stipulates the percent of the Work to be performed with the Bidders' own forces. The Bidder shall list all SLBE, ELBE, DBE, DVBE, MBE, WBE, OBE, SDB, WoSB, HUBZone, and SDVOSB Subcontractors that Bidders are seeking recognition towards achieving any mandatory, voluntary, or both subcontracting participation percentages.

NAME, ADDRESS AND TELEPHONE NUMBER OF SUBCONTRACTOR	CONTRACTOR OR DESIGNER	TYPE OF WORK	DOLLAR VALUE OF SUBCONTRACT	MBE, WBE, DBE, DVBE, OBE, ELBE, SLBE, SDB, WoSB, HUBZone, OR SDVOSB	WHERE CERTIFIED	CHECK IF JOINT VENTURE PARTNERSHIP
LUZBACH STRIPING INC, DBA Name: <u>LSF ROAD MARKING</u> Address: <u>PO BOX 2426</u> State: <u>CA</u> City: <u>EL CAJON</u> Phone: <u>619-443-7755</u> Zip: <u>92021</u>	CONTRACTOR	STRIPING	\$1,800.00	SB SLBE	SAN DIEGO CA	
Name: <u>FRANK S SON PAVING, INC.</u> Address: <u>1019 THIRD AVENUE</u> City: <u>CHULA VISTA</u> State: <u>CA</u> Zip: <u>91911</u> Phone: <u>619-422-8322</u>	CONTRACTOR	ASPHALT	\$ 3,600.80	MBE		
Name: <u>SELECT ELECTRIC, INC.</u> Address: <u>PO BOX 1357</u> City: <u>SPRING VALLEY</u> State: <u>CA</u> Zip: <u>91919</u> Phone: <u>619-460-6060</u>	CONTRACTOR	ELECTRICAL	\$43,935.00	MBE	SAN DIEGO CA	

HTA

① As appropriate, Bidder shall identify Subcontractor as one of the following and shall include a valid proof of certification (except for OBE, SLBE and ELBE):

- MBE
- Certified Minority Business Enterprise
- DBE
- Certified Disadvantaged Business Enterprise
- OBE
- Other Business Enterprise
- SLBE
- Certified Small Local Business Enterprise
- WoSB
- Woman-Owned Small Business
- SDVOSB
- Service-Disabled Veteran Owned Small Business

② As appropriate, Bidder shall indicate if Subcontractor is certified by:

- CITY
- City of San Diego
- CPUC
- California Public Utilities Commission
- CADoGS
- State of California's Department of General Services
- CA
- State of California
- MBE
- Certified Woman Business Enterprise
- DBE
- Certified Disabled Veteran Business Enterprise
- OBE
- Certified Emerging Local Business Enterprise
- SLBE
- Small Disadvantaged Business
- WoSB
- Woman-Owned Small Business
- SDVOSB
- Service-Disabled Veteran Owned Small Business

The Bidder will not receive any subcontracting participation percentages if the Bidder fails to submit the required proof of certification.

Form Title: LIST OF SUBCONTRACTORS

Form Number: AA35

Kelton Road Sidewalk Improvements

(Rev. July 2012)

14 | Page

BIDDING DOCUMENTS

LIST OF SUBCONTRACTORS

In accordance with the requirements provided in the "Subletting and Subcontracting Fair Practices Act", Division 2, Part 1, Chapter 4 of the Public Contract Code, the Bidder shall list below the name and address of each Subcontractor who will perform work, labor, render services or specially fabricates and installs a portion [type] of the work or improvement, in an amount in excess of 0.5% of the Contractor's total Bid. The Bidder shall also list below the portion of the work which will be done by each subcontractor under this Contract. The Contractor shall list only one Subcontractor for each portion of the Work. The **DOLLAR VALUE** of the total Bid to be performed shall be stated for all subcontractors listed. Failure to comply with this requirement shall result in the Bid being rejected as **non-responsive** and ineligible for award. The Bidder's attention is directed to the Special Provisions - General; Paragraph 2-3 Subcontracts, which stipulates the percent of the Work to be performed with the Bidders' own forces. The Bidder shall list all SLBE, ELBE, DBE, DVBE, MBE, WBE, OBE, SDB, WoSB, HUBZone, and SDVOSB Subcontractors that Bidders are seeking recognition towards achieving any mandatory, voluntary, or both subcontracting participation percentages.

NAME, ADDRESS AND TELEPHONE NUMBER OF SUBCONTRACTOR	CONSTRUCTOR OR DESIGNER	TYPE OF WORK	DOLLAR VALUE OF SUBCONTRACT	MBE, WBE, DBE, DVBE, OBE, ELBE, SLBE, SDB, WoSB, HUBZone, OR SDVOSB	WHERE CERTIFIED	CHECK IF JOINT VENTURE PARTNERSHIP
Name: <u>ACE FENCE COMPANY</u> Address: <u>727 NORTH GLENDORA AVE.</u> City: <u>LA BREA</u> State: <u>CA</u> Zip: <u>91744</u> Phone: <u>626-333-0727</u>	<u>CONSTRUCTOR</u>	<u>FENCING</u>	<u>\$ 11,003.00</u>	<u>DBE</u>	<u>CA</u>	
Name: _____ Address: _____ City: _____ State: _____ Zip: _____ Phone: _____						
Name: _____ Address: _____ City: _____ State: _____ Zip: _____ Phone: _____						

① As appropriate, Bidder shall identify Subcontractor as one of the following and shall include a valid proof of certification (except for OBE, SLBE and ELBE):

- Certified Minority Business Enterprise
- Certified Disadvantaged Business Enterprise
- Other Business Enterprise
- Certified Small Local Business Enterprise
- Woman-Owned Small Business
- Service-Disabled Veteran Owned Small Business
- MBE
- DBE
- OBE
- SLBE
- WoSB
- SDVOSB
- Certified Woman Business Enterprise
- Certified Disabled Veteran Business Enterprise
- Certified Emerging Local Business Enterprise
- Small Disadvantaged Business
- HUBZone Business
- WBE
- DVBE
- ELBE
- SDB
- HUBZone

② As appropriate, Bidder shall indicate if Subcontractor is certified by:

- City of San Diego
- California Public Utilities Commission
- State of California's Department of General Services
- State of California
- CITY
- CPUC
- CADoGS
- CA
- State of California Department of Transportation
- San Diego Regional Minority Supplier Diversity Council
- City of Los Angeles
- U.S. Small Business Administration
- CALTRANS
- SRMSDC
- LA
- SBA

The Bidder will not receive any subcontracting participation percentages if the Bidder fails to submit the required proof of certification.

BIDDING DOCUMENTS

NAMED EQUIPMENT/MATERIAL SUPPLIER LIST

The Bidder seeking the recognition of equipment, materials, or supplies obtained from Suppliers towards achieving any mandatory, voluntary, or both subcontracting participation percentages shall list the Supplier(s) on the Named Equipment/Material Supplier List. The Named Equipment/Material Supplier List, at a minimum, shall have the name, location (City) and the **DOLLAR VALUE** of the Suppliers. The Bidder will be credited up to 60% of the amount to be paid to the Suppliers for such materials and supplies unless vendor manufactures or substantially alters materials and supplies in which case 100% will be credited. The Bidder is to indicate (Yes/No) whether listed firm is a supplier or manufacturer. In calculating the subcontractor participation percentages, vendors/suppliers will receive 60% credit of the listed **DOLLAR VALUE**, whereas manufacturers will receive 100% credit. If no indication provided, listed firm will be credited at 60% of the listed **DOLLAR VALUE** for purposes of calculating the subcontractor participation percentages.

NAME, ADDRESS AND TELEPHONE NUMBER OF VENDOR/SUPPLIER	MATERIALS OR SUPPLIES	DOLLAR VALUE OF MATERIAL OR SUPPLIES	SUPPLIER (Yes/No)	MANUFACTURER (Yes/No)	MBE, WBE, DBE, DVBE, OBE, ELBE, SLBE, SDB, WOSB, HUBZone, OR SDVOSB	WHERE CERTIFIED
Name: _____ Address: _____ City: _____ State: _____ Zip: _____ Phone: _____						
Name: _____ Address: _____ City: _____ State: _____ Zip: _____ Phone: _____						
Name: _____ Address: _____ City: _____ State: _____ Zip: _____ Phone: _____						

① As appropriate, Bidder shall identify Vendor/Supplier as one of the following and shall include a valid proof of certification (except for OBE, SLBE and ELBE):

- | | | | |
|---|--------|--|---------|
| Certified Minority Business Enterprise | MBE | Certified Woman Business Enterprise | WBE |
| Certified Disadvantaged Business Enterprise | DBE | Certified Disabled Veteran Business Enterprise | DVBE |
| Other Business Enterprise | OBE | Certified Emerging Local Business Enterprise | ELBE |
| Certified Small Local Business Enterprise | SLBE | Small Disadvantaged Business | SDB |
| Woman-Owned Small Business | WOSB | HUBZone Business | HUBZone |
| Service-Disabled Veteran Owned Small Business | SDVOSB | | |

② As appropriate, Bidder shall indicate if Vendor/Supplier is certified by:

- | | | | |
|--|--------|--|----------|
| City of San Diego | CITY | State of California Department of Transportation | CALTRANS |
| California Public Utilities Commission | CPUC | San Diego Regional Minority Supplier Diversity Council | SRMSDC |
| State of California's Department of General Services | CADoGS | City of Los Angeles | LA |
| State of California | CA | U.S. Small Business Administration | SBA |

The Bidder will not receive any subcontracting participation percentages if the Bidder fails to submit the required proof of certification.

City of San Diego



Small Local Business Enterprise Certification

HTA Engineering and Construction, Inc.

Emerging Local Business Enterprise (ELBE)

Construction (NAICS: 237110, 237310, 237990, 238110)

Certification Number: 10HT0013

Effective Date: 07/01/2012

Expiration Date: 07/01/2014

A handwritten signature in cursive script, reading "Debra Fischle-Faulk".

Debra Fischle-Faulk
Administration Department
Director



THE CITY OF SAN DIEGO

April 25, 2012

HTA Engineering & Construction, Inc.
Attention: Hatim T. Askar
5450 Complex St. Suite 303
San Diego, CA 92123

Subject: City of San Diego Contractor Prequalification Program Status

Dear Mr. Askar:

Thank you for submitting your contractor prequalification program renewal questionnaire. We have reviewed and evaluated your questionnaire and are pleased to inform you that HTA Engineering & Construction, Inc., under license number 798372, is prequalified for a maximum bidding capacity of \$2,000,000 per project.

Effective the date of this letter, you are eligible to bid on City of San Diego public works projects valued at up to \$2,000,000, excluding those that are administered by the Small Local Business Enterprise Program (unless you meet the program requirements). **Your prequalification is valid until April 30, 2014.** After that date, you will not be allowed to bid on City public works projects valued at over \$50,000 until your prequalification is renewed.

You have five (5) working days from the date of this letter to contact me should you have any questions concerning your designated status. I can be reached at (619) 533-3125 or email MHaines@sandiego.gov.

We appreciate your interest in renewing your prequalification and look forward to your participation on future projects.

Sincerely,

Michele Haines
Contractor Prequalification Program Administrator



Engineering and Capital Projects Department
Contractor Pre-Qualification Program • 1010 Second Avenue, Suite 800 • San Diego, CA 92101-4905
Tel (619) 533-3474





THE CITY OF SAN DIEGO

November 26, 2010

Luzaiach Striping Inc.
DBA LSI Road Marking
Rodney Luzaiach
14219 Olde Highway 80
El Cajon, CA 91902

Subject: Small Local Business Enterprise Certification

Dear Mr. Luzaiach: *Rodney*

Congratulations! We have reviewed your application and you have been approved for certification as a City of San Diego Small Local Business Enterprise (SLBE). Your certification number is 11LS0275 and your classification is Specialty Construction. Please reference this certification number when bidding on City projects.

For the City's SLBE Program, your certification is effective November 19, 2010. This certification expires on November 19, 2012 at which time you will need to reapply in accordance with the SLBE guidelines.

If you have any questions please call 619-236-6297.

Thank you,

Debra Fischle-Faulk
Debra Fischle-Faulk
Department Director



Administration Department
Small Local Business Enterprise Program
202 C Street, 9th Floor, MS 9A
San Diego, CA 92101-4806
Telephone (619) 236-6297 Fax (619) 236-7344



San Diego Regional
Minority Supplier Development Council

July 25, 2012

Mario Tapanes
Select Electric, Inc.
P.O. Box 1457
Spring Valley, CA 91979

Dear Mario,

I am pleased to inform you that the San Diego Regional Minority Supplier Development Council has approved your recertification as a Minority Business Enterprise (MBE). Enclosed is your new certificate, which is valid through July 26, 2013.

Continuing to serve you as the premier business organization that links private sector corporations with minority businesses is our primary goal.

I look forward to your continued participation in our events and special programs.

Sincerely,

Ronald B. Garnett
President & CEO

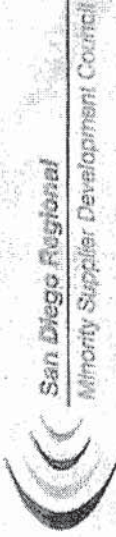

SAN DIEGO REGIONAL MINORITY SUPPLIER DEVELOPMENT COUNCIL

THIS CERTIFIES THAT

Select Electric, Inc.

Has met the requirements for certification as a bona fide Minority Business Enterprise as defined by the National Minority Supplier Development Council, Inc.® (NMSDC®) and as adopted by the San Diego Regional Minority Supplier Development Council

**NAICS Code(s): 238210 ;

**Description of their product/services as defined by the North American Industry Classification System (NAICS)

July 25, 2012

Issued Date

July 26, 2013

Expiration Date

SD06593

Certificate Number

[Signature]
President, SDRMSDC

By using your assigned (through NMSDC only) password, NMSDC Corporate Members may view the original certificate by logging in at: <http://www.nmsdc.org>



An affiliate of the National Minority Supplier Development Council, Inc. (NMSDC)

CALIFORNIA UNIFIED CERTIFICATION PROGRAM (CUCP)



December 15, 2009

Ms. America Tang
APW Construction, Inc.
dba Ace Fence Company
727 N. Glendora Avenue
La Puente, CA 91744

Expires 12/15/2014

**RE: DISADVANTAGED BUSINESS ENTERPRISE (DBE)
CERTIFICATION APPROVAL File No. - 642**

Dear Ms. Tang:

We are pleased to advise you that after careful review of your application and supporting documentation, the City of Los Angeles has determined that your firm meets the eligibility standards to be certified as a **Disadvantaged Business Enterprise (DBE)** as required under the U.S. Department of Transportation (U.S. DOT) Regulation 49 CFR Part 26, as amended.

Your firm will be listed in the California Unified Certification Program (CUCP) database of certified DBEs and the City of Los Angeles DBE/MBE/WBE directory under the following specific area of expertise that you have identified on the business service form for contracting opportunities:

<u>NAICS Code</u>	<u>Description</u>
238990	All Other Specialty Trade Contractors

Your DBE certification is good for five years from the date of this letter and applies only for the above codes. You may review your firm's information in the CUCP DBE database which can be accessed at the California Department of Transportation's website at www.dot.ca.gov/hq/bep/ and the City of Los Angeles DBE/MBE/WBE database at <http://bca.lacity.org>. Any additions and revisions must be submitted to the City of Los Angeles for review and approval.

After the five-year certification period, your entire file will be reviewed in order to ascertain continued DBE certification status. You will be notified of the pending DBE status review and any documentation update necessary prior to the expiration date.

The Regulations also require annual updates during this five-year period. In order to assure continuing DBE status, you must submit annually a DBE Declaration with supporting documentation, in the format, which will be sent to you. Based on your annual submission that no change in ownership and control has occurred, or if changes have occurred, they do not affect your firm's DBE standing, the DBE certification of your firm will continue until the five-year certification has expired.

APW Construction, Inc.
December 15, 2009
Page 2

Also, should any changes occur that could affect your certification status prior to receipt of the DBE Declaration, such as changes in your firm's name, business/ mailing address, ownership, management, or control, or failure to meet the applicable business size standards or personal net worth standard, please notify us immediately. DBE certification is subject to review at any time. Failure to submit forms and/or change of information will be deemed as failure to cooperate under Section 26.109 of the Regulations.

Your DBE certification status will be honored by all of the U.S. DOT recipients in California.

Congratulations, and thank you for your interest in the California Unified Certification Program (CUCP). We wish you every business success and look forward to hearing from you if we may be of any assistance to you in this regard.

Should you have any questions, please contact Kim Fitzpatrick at (213) 847-2644 or e-mail at kim.fitzpatrick@lacity.org.

Sincerely,



^{for} HELMUT PEINDL, Certification Manager
Office of Contract Compliance
Bureau of Contract Administration

CALIFORNIA UNIFIED CERTIFICATION PROGRAM DISADVANTAGED BUSINESS ENTERPRISE CERTIFICATE

ACE FENCE COMPANY

727 N. GLENDORA AVENUE,
LA PUENTE, CA 91744

Owner: AMERICA TANG

Business Structure: CORPORATION

This certificate acknowledges that said firm is approved by the California Unified Certification Program (CUCP) as a Disadvantaged Business Enterprise (DBE) as defined by the U.S. Department of Transportation (DOT) CFR 49 Part 26, as may be amended, for the following NAICS codes:

- NAICS Code(s) * Indicates primary NAICS code
* 238990 All Other Specialty Trade Contractors

Work Category Code(s)

C0680 FENCING

Licenses

A General Engineering Contractor

B General Building Contractor

C13 Fencing Contractor

CERTIFYING AGENCY:

CITY OF LOS ANGELES
1149 SOUTH BROADWAY STREET
LOS ANGELES, CA 90015 0000
(213) 847-1922

UCP Firm Number: 34153

Ann Fitzpatrick
CUCP OFFICER

December 15, 2009

KELTON RD PEDESTRIAN IMPROVEMENT

UNDERGROUND UTILITIES

AT LEAST THREE (3) WORKING DAYS PRIOR TO EXCAVATION, THE CONTRACTOR SHALL REQUEST A MARKOUT OF UNDERGROUND UTILITIES BY CALLING THE BELOW LISTED REGIONAL NOTIFICATION CENTER FOR AN INQUIRY IDENTIFICATION NUMBER:
 UNDERGROUND SERVICE ALERT (U.S.A.) 1-800-422-4133

CONTRACTOR'S RESPONSIBILITIES

- CONTRACTOR SHALL ASSUME SOLE AND COMPLETE RESPONSIBILITY FOR JOB SITE CONDITIONS DURING THE COURSE OF CONSTRUCTION OF THIS PROJECT INCLUDING: SAFETY OF ALL PERSONS AND PROPERTY, AND THAT THIS REQUIREMENT SHALL APPLY CONTINUOUSLY AND NOT BE LIMITED TO NORMAL WORKING HOURS.
- CONTRACTOR SHALL ASSUME SOLE AND COMPLETE RESPONSIBILITY FOR JOB SITE CONDITIONS DURING THE COURSE OF CONSTRUCTION OF THIS PROJECT INCLUDING: SAFETY OF ALL PERSONS AND PROPERTY, AND THAT THIS REQUIREMENT SHALL APPLY CONTINUOUSLY AND NOT BE LIMITED TO NORMAL WORKING HOURS.
- THE CONTRACTOR SHALL BE RESPONSIBLE TO INSURE THAT ALL DETAILS ARE BUILT IN ACCORDANCE WITH THESE PLANS. IF THERE IS ANY QUESTION REGARDING THESE PLANS, THE CONTRACTOR SHALL REQUEST AN INTERPRETATION BEFORE DOING ANY WORK BY CALLING THE CITY RESIDENT ENGINEER.
- CONTRACTOR WILL MAKE EXPLORATION EXCAVATIONS AND LOCATE EXISTING UNDERGROUND FACILITIES SUFFICIENTLY AHEAD OF CONSTRUCTION TO PERMIT REVISIONS TO PLANS IF REVISIONS ARE NECESSARY BECAUSE OF ACTUAL LOCATION OF EXISTING FACILITIES.
- LOCATION AND ELEVATION OF IMPROVEMENTS TO BE MET BY WORK TO BE DONE SHALL BE CONFIRMED BY FIELD MEASUREMENTS PRIOR TO CONSTRUCTION OF NEW WORK.
- BEFORE EXCAVATING FOR THIS CONTRACT, VERIFY LOCATION OF UNDERGROUND UTILITIES, THE EXISTENCE AND LOCATION OF ANY UNDERGROUND UTILITY PIPES OR STRUCTURES SHOWN ON THESE PLANS WERE OBTAINED BY A SEARCH OF THE AVAILABLE RECORDS, TO THE BEST OF OUR KNOWLEDGE THERE ARE NO OTHER EXISTING UTILITIES EXCEPT AS SHOWN ON THESE PLANS.
- CONTRACTOR IS REQUIRED TO TAKE PRECAUTIONARY MEASURES TO PROTECT THE UTILITY LINES SHOWN HEREON AND ANY OTHER EXISTING LINES NOT OF RECORD OR NOT SHOWN ON THESE PLANS.
- THE CONTRACTOR SHALL BE RESPONSIBLE FOR ANY MONUMENTATION AND/OR BENCHMARKS WHICH WILL BE DISTURBED OR DESTROYED BY CONSTRUCTION, SUCH POINTS SHALL BE REFERENCED AND REPLACED WITH APPROPRIATE MONUMENTATION BY A LICENSED LAND SURVEYOR OR A REGISTERED CIVIL ENGINEER AUTHORIZED TO PRACTICE LAND SURVEYING. A CORNER RECORD OR RECORD OF SURVEY, AS APPROPRIATE, SHALL BE FILED BY THE LICENSED LAND SURVEYOR OR REGISTERED CIVIL ENGINEER AS REQUIRED BY THE LAND SURVEYOR'S ACT.
- THE CONTRACTOR SHALL NOTIFY THE CITY TRAFFIC ENGINEER AT LEAST FIVE (5) WORKING DAYS IN ADVANCE OF IMPLEMENTING ANY CONSTRUCTION DETOUR.
- IF CONSTRUCTION IS TO BE PERFORMED IN STAGES, ALL WORK SHALL BE COMPLETED IN EACH STAGE PRIOR TO BEGINNING WORK ON THE NEXT STAGE.
- THE CONTRACTOR SHALL ALSO TAKE THE NECESSARY STEPS TO PROTECT ADJACENT PROPERTY FROM ANY EROSION AND SILTATION THAT RESULTS FROM HIS OPERATIONS BY APPROPRIATE MEANS (GRAVEL BAG, DIKES, ETC) UNTIL SUCH TIME THAT THE PROJECT IS COMPLETE AND ACCEPTED FOR MAINTENANCE BY CITY.
- THE CONTRACTOR TO PROVIDE STOCK PILE PROTECTION, STREET SWEEPING, STORAGE/STAGING AREA PROTECTION, POLLUTION CONTROL MEASURES FOR EQUIPMENT MAINTENANCE, FUELING, CLEANING AND STORAGE AND TEMPORARY CONCRETE WASH OUT AREA.

ABBREVIATIONS

ABAND	ABANDON	EL, ELEV	ELEVATION	PROP	PROPOSED
ABAND'D	ABANDONED	ELEC	ELECTRIC	RT	RIGHT
BTWN	BETWEEN	EX, EXIST	EXISTING	℄	SURVEY LINE
CATV	CABLE TV	HP	HIGH PRESSURE	SWR	SEWER
℄	CENTER LINE	TEL	TELEPHONE	UNK	UNKNOWN
COND	CONDUIT				

EXISTING STRUCTURES

EX INLET	
EX CHAIN LINK FENCE	
EX WATER VALV E	
EX WATER METER	
EX FIRE HYDRANT	
EX SEWER MAIN & MANHOLES	
EX DRAINS	
EX PAVEMENT (PROFILE)	
EX GROUND LINE (PROFILE)	
EX TRAFFIC SIGNAL	
EX STREET LIGHT	
GAS MAIN	
ELEC. COND., TEL. COND., CATV	

LIMITS OF WORK

SHEET NO.	DISCIPLINE CODE	TITLE	LIMITS
1	G-1	COVER SHEET	KELTON ROAD
2	C-1	CROSS SECTION	KELTON ROAD
3	C-2	CIVIL	KELTON ROAD
4	C-3	CIVIL	KELTON ROAD
5	T-1	SIGNAGE AND STRIPING	KELTON ROAD

DISCIPLINE CODE

G	GENERAL
D	DEMOLITION
C	CIVIL
L	LANDSCAPE
A	ARCHITECTURAL
S	STRUCTURAL
M	MECHANICAL
E	ELECTRICAL
I	INSTRUMENTATION
T	TRAFFIC CONTROL

- THE CONTRACTOR SHALL NOTIFY ALL AFFECTED UTILITY AGENCIES A MINIMUM OF FIVE(5) WORKING DAYS PRIOR TO EXCAVATION NEAR UTILITY FACILITIES AND SHALL COORDINATE WITH THEM:

SDG&E	1-800-236-6323	AT&T	1-800-422-4131
CITY SEWER	1-800-236-5660	COX CABLE	619-262-1181
CITY WATER	1-800-236-5650		
CITY COMMUNICATIONS AND ELECTRICAL DIVISION	1-800-236-5505		
UNDERGROUND SERVICES ALERT (USA)	1-800-422-4133		

STORM WATER PROTECTION

THIS PROJECT IS SUBJECT TO MUNICIPAL STORM WATER PERMIT ORDER R9-2007-0001 AND WPCP.

WORK TO BE DONE

THE IMPROVEMENTS CONSIST OF THE FOLLOWING WORK TO BE DONE ACCORDING TO THESE PLANS AND THE STANDARD SPECIFICATIONS AND THE STANDARD DRAWINGS OF THE CITY OF SAN DIEGO.

LEGEND

IMPROVEMENTS	STANDARD DRAWINGS	SYMBOL
SIDEWALK	SDG-155	
CURB AND GUTTER	SDG-151	
NO. 3-1/2 PULLBOX	CALTRANS ES-8	
METAL BEAM GUARDRAIL	CALTRANS A77AI, HI	
PROPOSED CURB RAMP TYPE 'B'	SDG-130/SDG-132	
NEW CHAIN LINK FENCE	SDM-112	
GRADE BEAM	SEE DETAIL	
ADDITIONAL AC PAVING	SEE SHEET 3	

FOR ADDITIONAL SYMBOLS SEE CURB RAMP AND TRAFFIC CONTROL SHEETS.

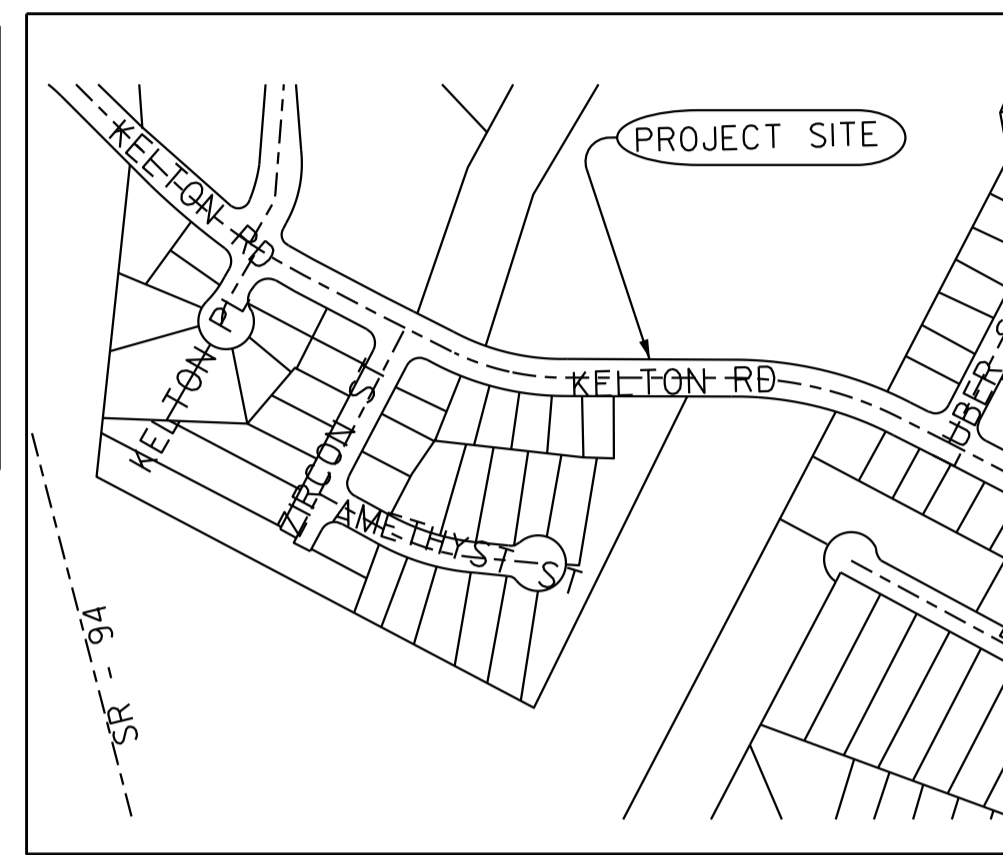

LOCATION MAP
NOT TO SCALE

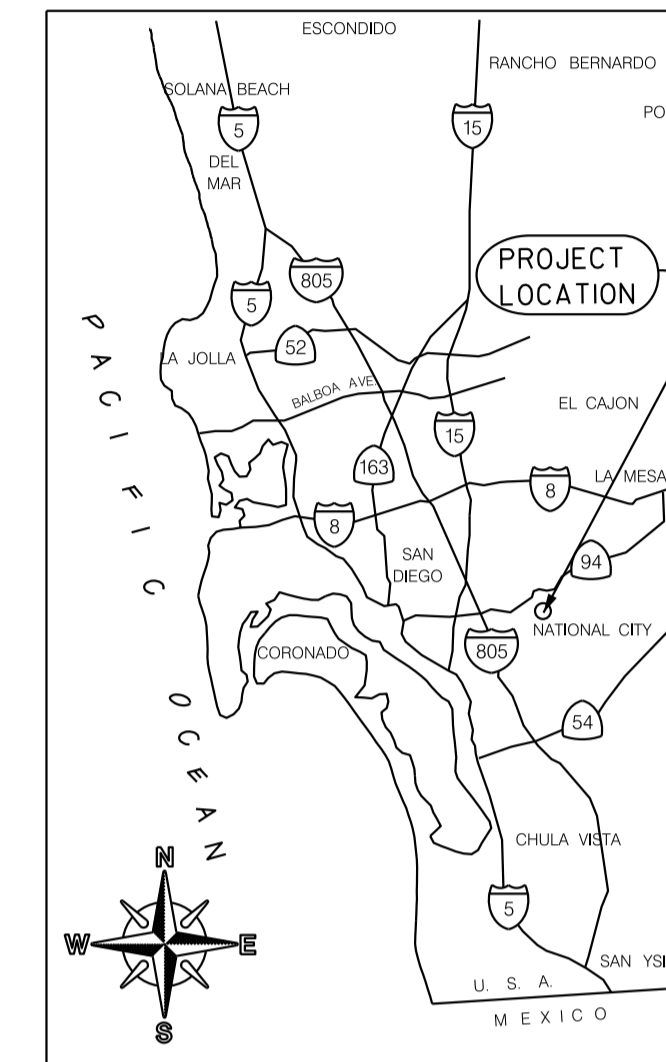

VICINITY MAP
NOT TO SCALE

STREET CLASSIFICATION

STREET NAME: KELTON ROAD
TWO LANE RESIDENTIAL, ADT=7300
DESIGN SPEED 30 MPH

REFERENCES:

Maps: 330, 3597, 6502
City Drawing: I3177-I-D

BASIS OF BEARINGS/COORDINATES:

The Basis of Bearings for this project was derived from a previous STATIC GPS Survey, using R.of S.14492 NAD 83 feet, Zone 6 (epoch 1991.35). Utilizing the RTK/GPS field procedures with the Base Station located randomly and constraining to GPS 1173 & GPS 1175 IE N19°10'32"E.

BENCH:

NWBP ZIRCON ST. & KELTON RD.
Elev. 299.042 MSL, Based on NGVD 29 FEET as shown in the City of San Diego Bench Book

CITY OF SAN DIEGO

TRAFFIC ENGINEER DATE 7/27/2012

TEMPORARY BMP CONSTRUCTION SITE STORM WATER PRIORITY: LOW

SPEC. NO. 5607

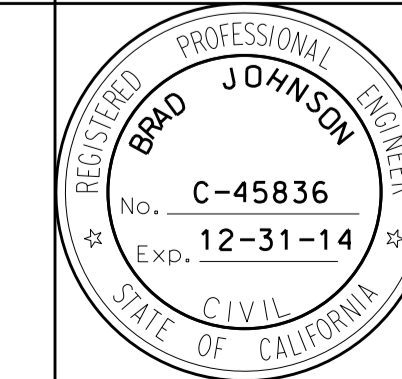

PLANS FOR THE CONSTRUCTION OF
KELTON RD PEDESTRIAN IMPROVEMENT
COVER SHEET

CITY OF SAN DIEGO, CALIFORNIA
ENGINEERING AND CAPITAL PROJECTS DEPARTMENT
SHEET _LOF_ 5_SHEETS

APPROVED:
FOR CITY ENGINEER DATE 2/12/2013
SUBMITTED BY: LOUIS SCHULTZ
ASSOCIATE ENGINEER

DESCRIPTION	BY	APPROVED	DATE	FILMED
ORIGINAL	KZ			

PROJECT ENGINEER: SABEEN COCHINWALA
202-1743
CCS27 COORDINATE
1842444-6304407
CCS83 COORDINATE

CONTRACTOR: _____ DATE STARTED: _____
INSPECTOR: _____ DATE COMPLETED: _____
36487-01-D

CONSTRUCTION CHANGE / ADDENDUM			
CHANGE	DATE	AFFECTED OR ADDED SHEET NUMBERS	APPROVAL NO.

WARNING

IF THIS BAR DOES NOT MEASURE 1" THEN DRAWING IS NOT TO SCALE.

CITY OF SAN DIEGO
PUBLIC WORKS PROJECT



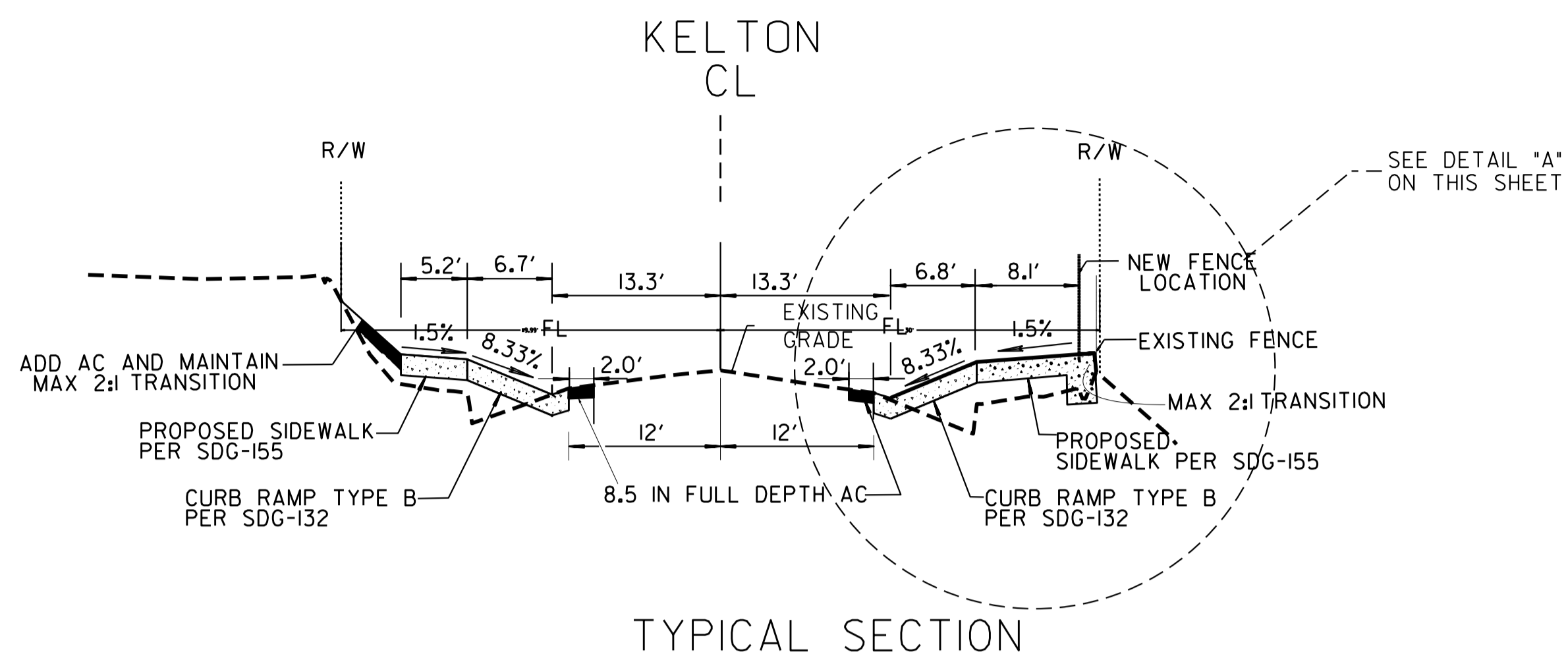

TYPICAL SECTION
CROSSWALK CURB RAMP SECTION
STA 0+40 TO STA 0+50 "KELTON_CL"

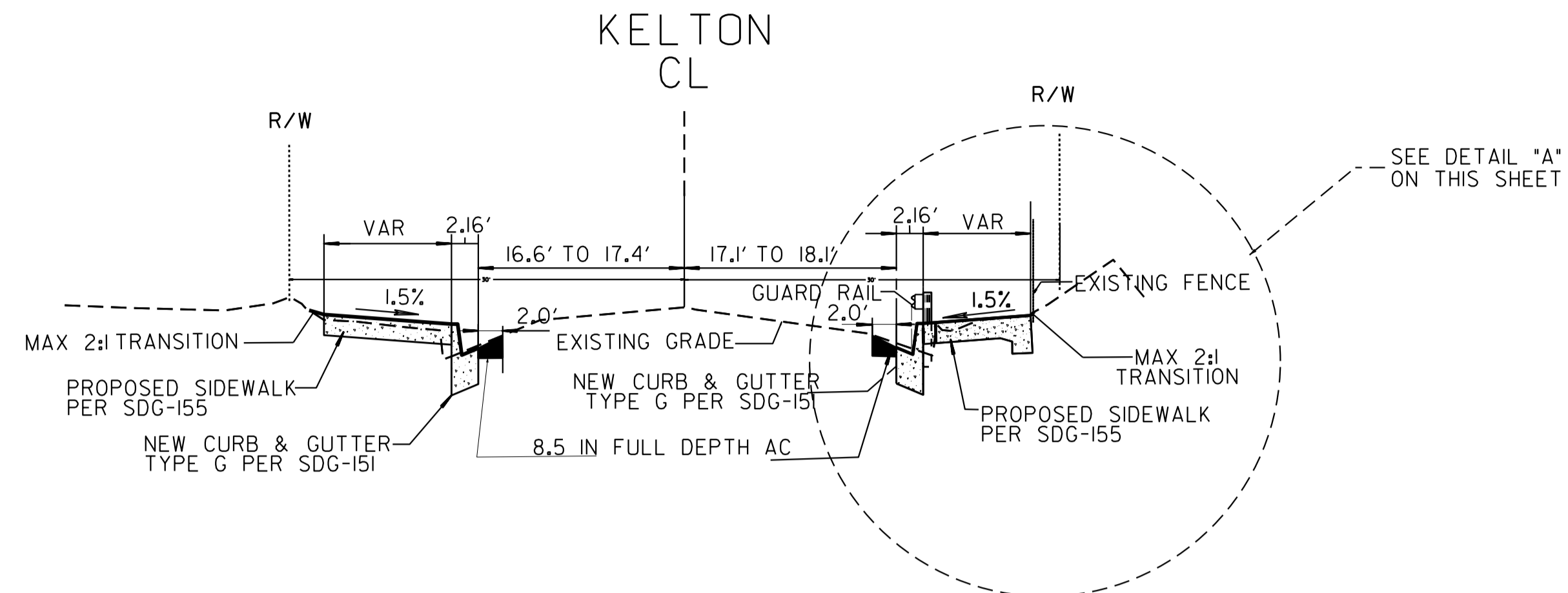

TYPICAL SECTION
STA 0+50 TO 0+85 "KELTON_CL"

NOTE:
•• GUARDRAIL DELINEATION PER A77C4

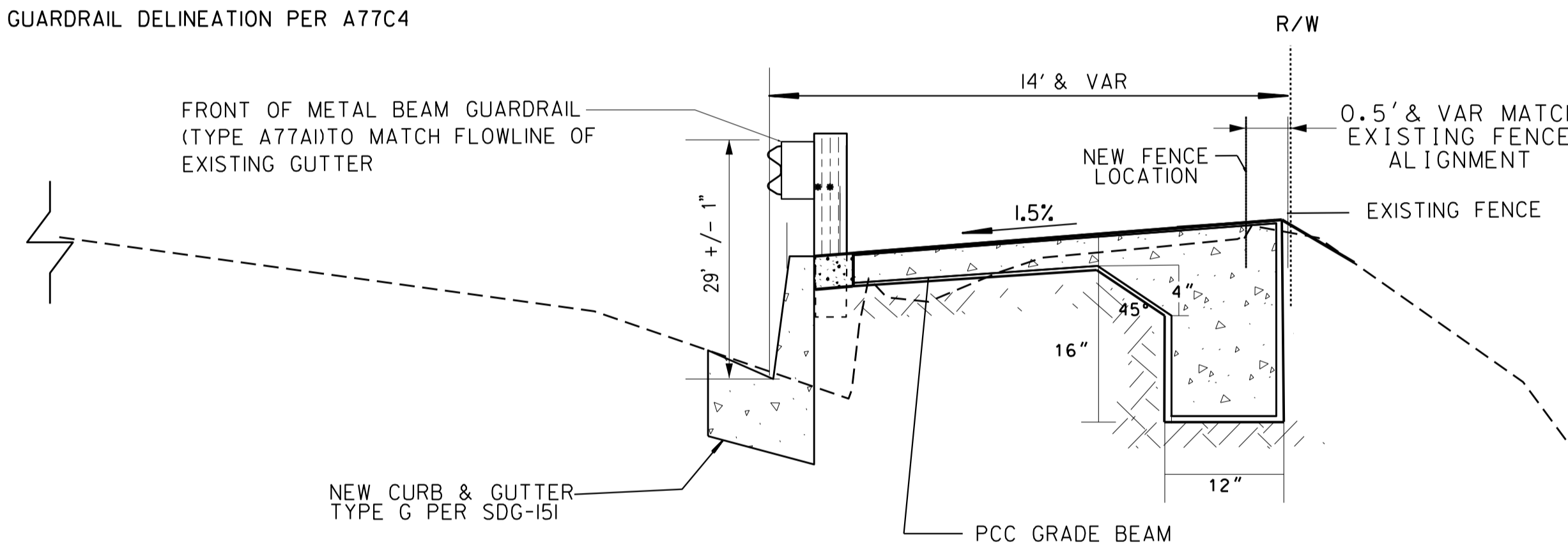

DETAIL "A" SECTION :
SIDEWALK GRADE BEAM
& GUARD RAIL
STA 0+40 TO 0+85
"KELTON_CL"

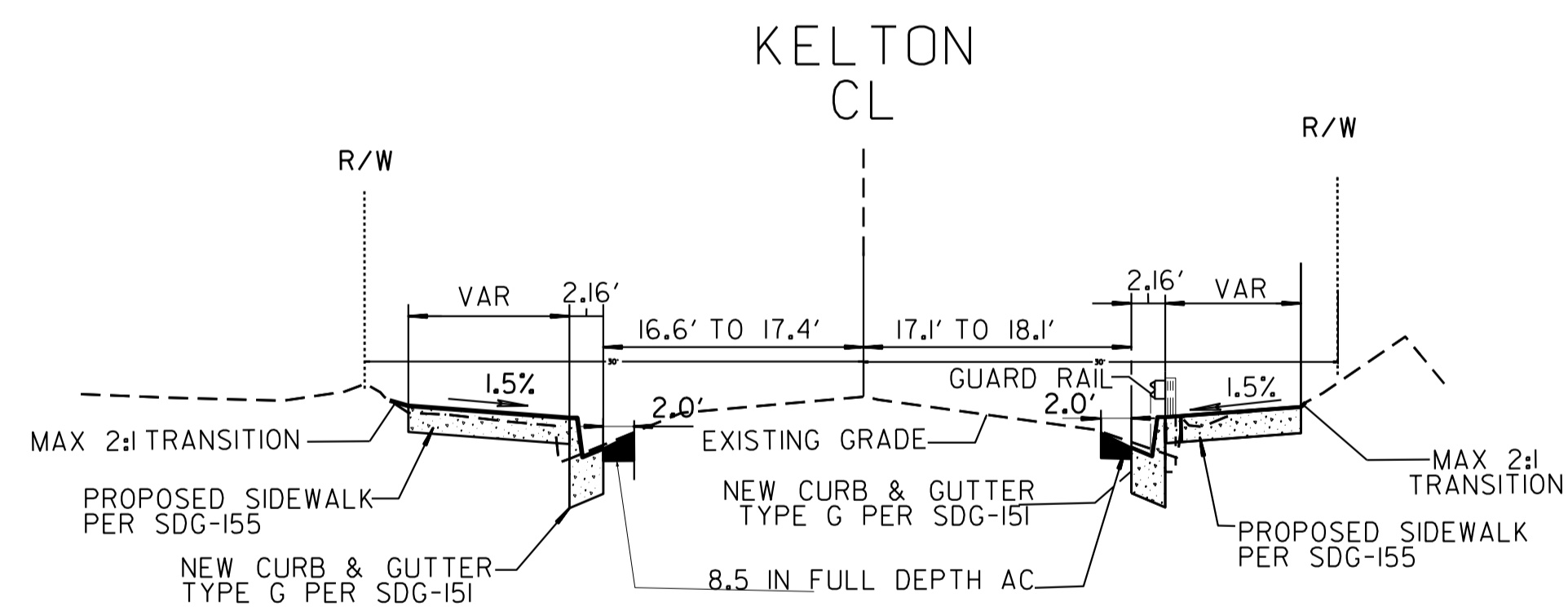

TYPICAL SECTION
STA 0+05 TO 0+40 "KELTON_CL"

NO SCALE

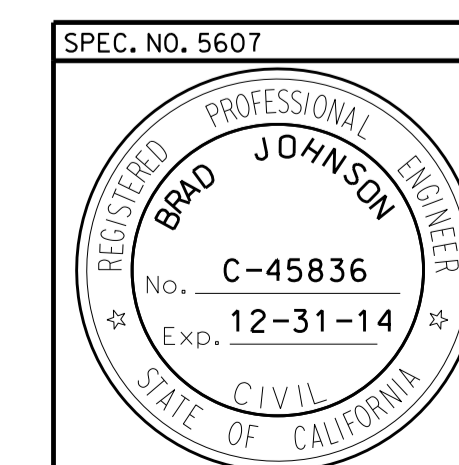

CROSS SECTION AND DETAIL FOR:			
KELTON RD PEDESTRIAN IMPROVEMENT PROJECT			
CITY OF SAN DIEGO, CALIFORNIA ENGINEERING AND CAPITAL PROJECTS DEPARTMENT SHEET 2 OF 5 SHEETS			w.b.s. S-10154
APPROVED:	DATE	DATE	DATE
<i>Brad Johnson</i>	2/12/2013		
FOR CITY ENGINEER	DATE	DATE	DATE
DESCRIPTION	DRAWN BY	APPROVED	DATE
ORIGINAL	KZ		
PROJECT ENGINEER			PROJECT ENGINEER
PROJECT ENGINEER			PROJECT ENGINEER
202-1743			202-1743
CCS27 COORDINATE			CCS27 COORDINATE
1842444-6304407			1842444-6304407
CCS88 COORDINATE			CCS88 COORDINATE
CONTRACTOR	DATE STARTED	DATE STARTED	DATE STARTED
INSPECTOR	DATE COMPLETED	DATE COMPLETED	DATE COMPLETED
			36487-2-D

GENERAL NOTES

- USE 36" DEEP X FULL WIDTH OF RAMP STAINLESS STEEL DETECTABLE WARNING TRUNCATED DOMES PER CITY'S AML
- ADJUST LOCATION/HEIGHT OF PEDESTRIAN SIGNAL PUSHBUTTON AS REQUIRED BY MUTCD
- CONTRACTOR TO CHECK ALL POLE SIGNS ALONG SIDEWALKS AND VERIFY THAT THEY ARE OUTSIDE THE PATH OF TRAVEL AND BOTTOM OF SIGN IS AT LEAST 7'-0" ABOVE SIDEWALK FINISH SURFACE ,IF NOT CONTRACTOR TO RELOCATE OR ADJUST
- CONTRACTOR TO REMOVE ALL BARRIERS ALONG SIDEWALK THAT WOULD BLOCK THE ACCESSIBLE ROUTE
- ADJUST CROSSWALK LIMIT LINES TO MATCH UP WITH NEW RAMPS

KELTON RD CL ALIGNMENT "KELTON_CL"			
POINT CHAINAGE (ft)	NORTHING (ft)	EASTING (ft)	
ELEMENT LENGTH (ft)	WCB (0°00'00")		
(STRAIGHT) WCB (0°00'00")			
(R=STARTING ANGLE) (R=END ANGLE)			
POB 0+00.00	1842532.926	6307820.756	
	STRAIGHT 37.05	S28°23'10" E	
PI0+37.05	1842500.329	6307838.371	
	STRAIGHT 24.13	S28°23'10" E	
PC 0+61.18	1842479.103	6307849.841	
	R = +500.00	32.87 S28°23'10" E S24°37'10" E	
PT 0+94.05	1842449.692	6307864.506	
	STRAIGHT 23.41	S24°37'10" E	
POE 1+17.46	1842428.414	6307874.257	

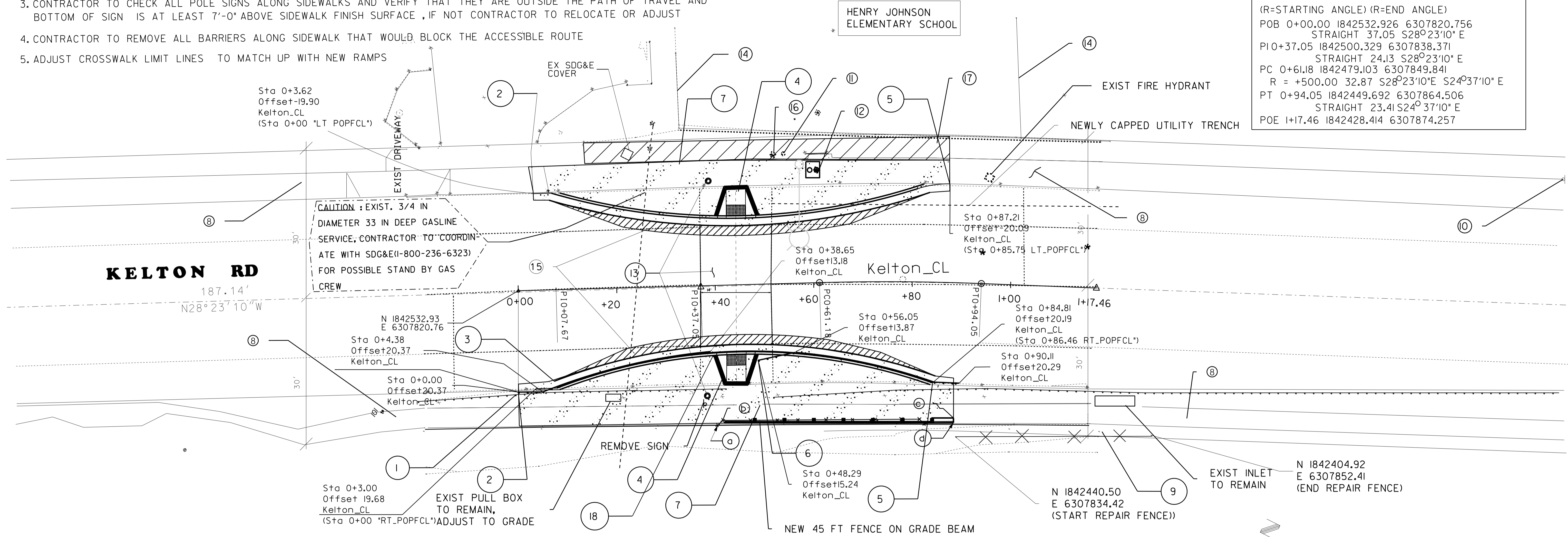

NOTES:

- REMOVE AND SALVAGE EXISTING GUARDRAIL AND INSTALL SALVAGED GUARDRAIL PER A77AI
- MATCH EXIST CURB AND GUTTER AND SIDEWALK AT START OF POPOUT
- MATCH EXIST AC AT LIP OF GUTTER
- INSTALL CURB RAMP TYPE B
- MATCH EXIST CURB AND GUTTER AND SIDEWALK AT END OF POPOUT
- INSTALL NEW GUARDRAIL END TREATMENT/SECTION PER A77HI (TYPE SFT) WITH 3FT SYSTEM END OFFSET, PER A77LI
- REMOVE EXISTING PAVEMENT, CURB, GUTTER AND SIDEWALK
- EXISTING 4 FT WIDE CONCRETE SIDEWALK PAVEMENT
- REPAIR 40FT OF EXISTING FENCE AND STABILIZE FOOTING
- EXISTING ADVANCE WARNING SIGN TO REMAIN
- REMOVE EXISTING SCHOOL CROSSING SIGN
- ADJUST EXISTING WATER MANHOLE VAULT TO GRADE
- INSTALL LIGHTED CROSSWALK (INCLUDING LADDER CROSSWALK, IN-PAVEMENT FLASHERS, PEDESTRIAN PUSH-BUTTON POLES & ELECTRICAL CONDUIT)
- EXISTING FENCE TO STAY IN PLACE
- ASPHALT BACK FILL PAVING OF MAX 2FT & VAR WIDTH
- ADJUST STREET LIGHT POLE BOX TO GRADE
- ADD AC TO ADJUST GRADE
- INSTALL NEW GUARDRAIL END TREATMENT/SECTION PER A77HI

FENCE PT	NORTHING (ft)	EASTING (ft)	ELEMENT LENGTH (ft)	BEARING
(a)	1842484.611	6307814.806	STRAIGHT 1.43'	S 71 41'35" E
(b)	1842484.162	6307816.162	STRAIGHT 39.95'	S 27 03'38" E
(c)	1842442.554	6307837.650	STRAIGHT 1.48'	S 18 21'08" W
(d)	1842442.118	6307836.765		

WARNING:
 LOCATION OF GAS & UTILITY LINES ARE APPROXIMATE AND CONTRACTOR SHALL ESTABLISH EXACT LOCATION AND DEPTH PRIOR TO CONSTRUCTION.
 NOTE: SDG&E REQUIRES THREE (3) WEEKS NOTICE TO ADJUST BOXES AND HANDHOLES

NOTE:
 EXISTING IMPROVEMENTS SHALL BE PROTECTED IN PLACE UNLESS NOTED OTHERWISE.

NOTE:
 TRAFFIC SHALL REMAIN OPEN WHILE CONSTRUCTION IS UNDERWAY.

KELTON ROAD IMPROVEMENT PLAN

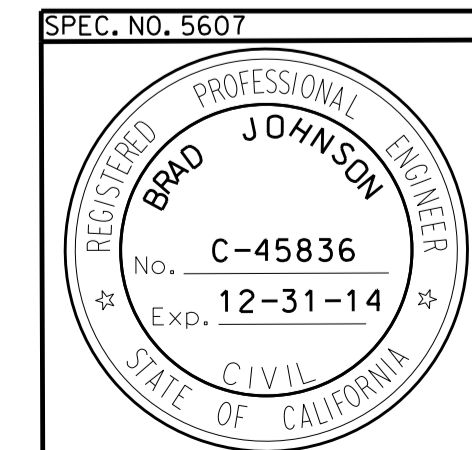
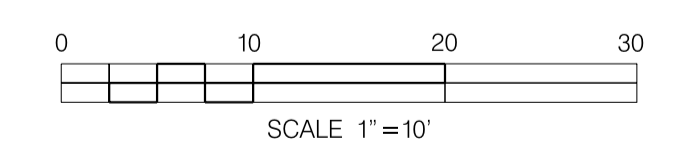

LAYOUT PLAN FOR: KELTON RD PEDESTRIAN IMPROVEMENT PROJECT			
CITY OF SAN DIEGO, CALIFORNIA ENGINEERING AND CAPITAL PROJECTS DEPARTMENT SHEET 3 OF 5 SHEETS		w.o. S-10154	
APPROVED FOR CITY ENGINEER	DATE 2/12/2013	LOUIS SCHULTZ ASSOCIATE ENGINEER	
DESCRIPTION ORIGINAL	DRAWN BY KZ	APPROVED	DATE
PROJECT ENGINEER		SABEEN COCHINWALA	
PROJECT NO.		202-1743	
COORDINATE		1842444-6304407	
CONTRACTOR		DATE STARTED	
INSPECTOR		DATE COMPLETED	
		36487-3-D	

KELTON RD PEDESTRIAN IMPROVEMENT PROJECT

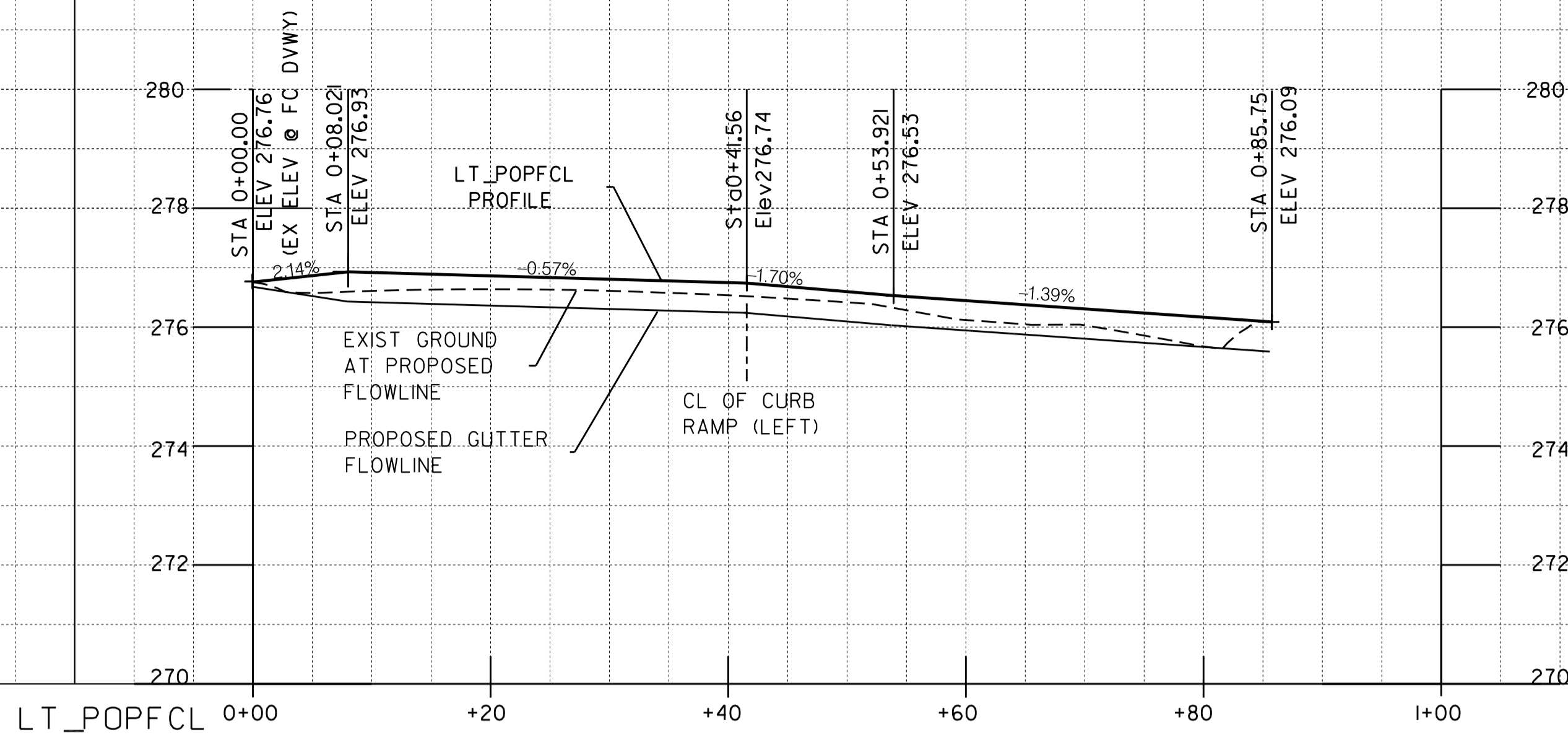

KELTON RD LEFT POPOUT TC @ FACE PROFILE

SCALE: HORIZ. 1:1
VERT. 1:5

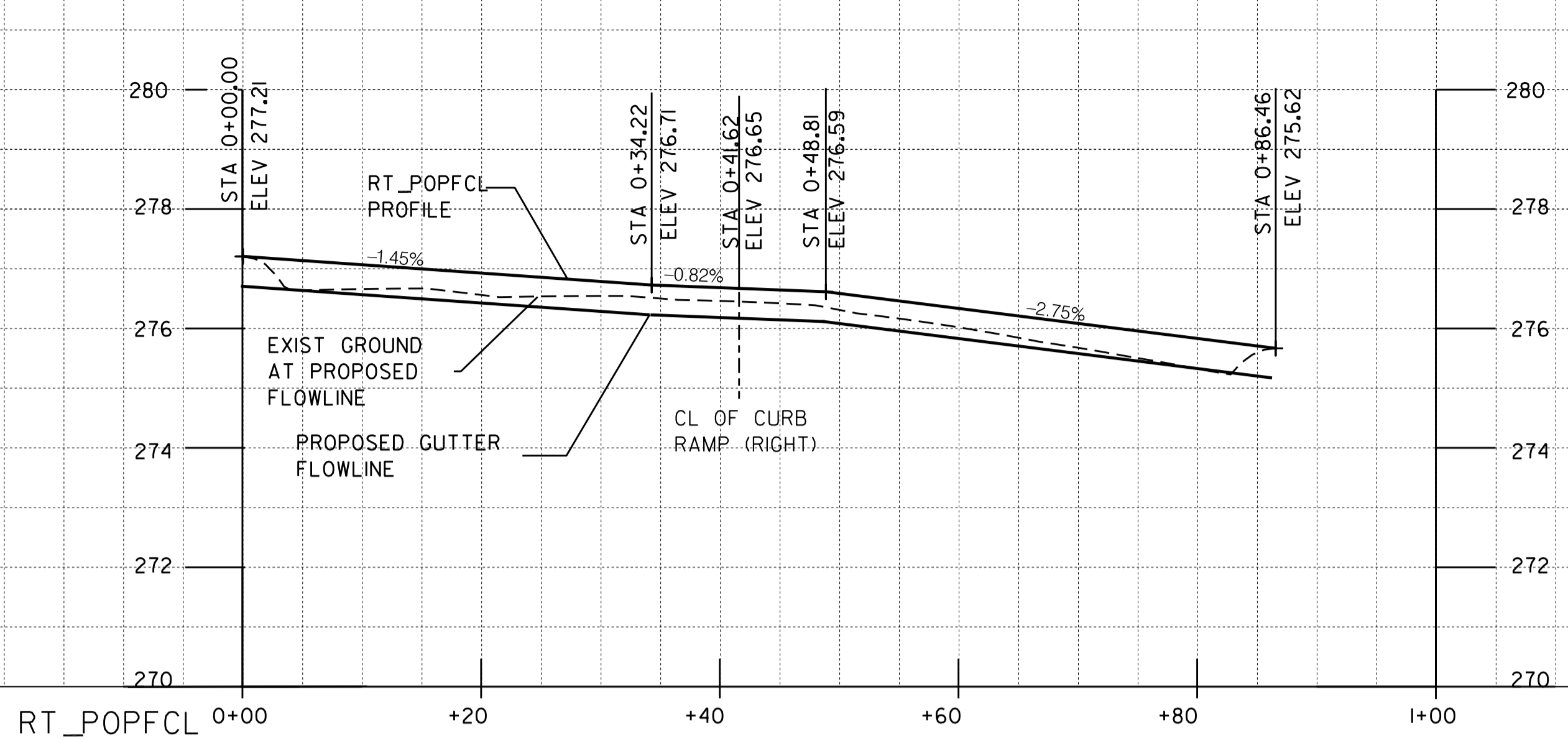

KELTON RD RIGHT POPOUT TC @ FACE PROFILE

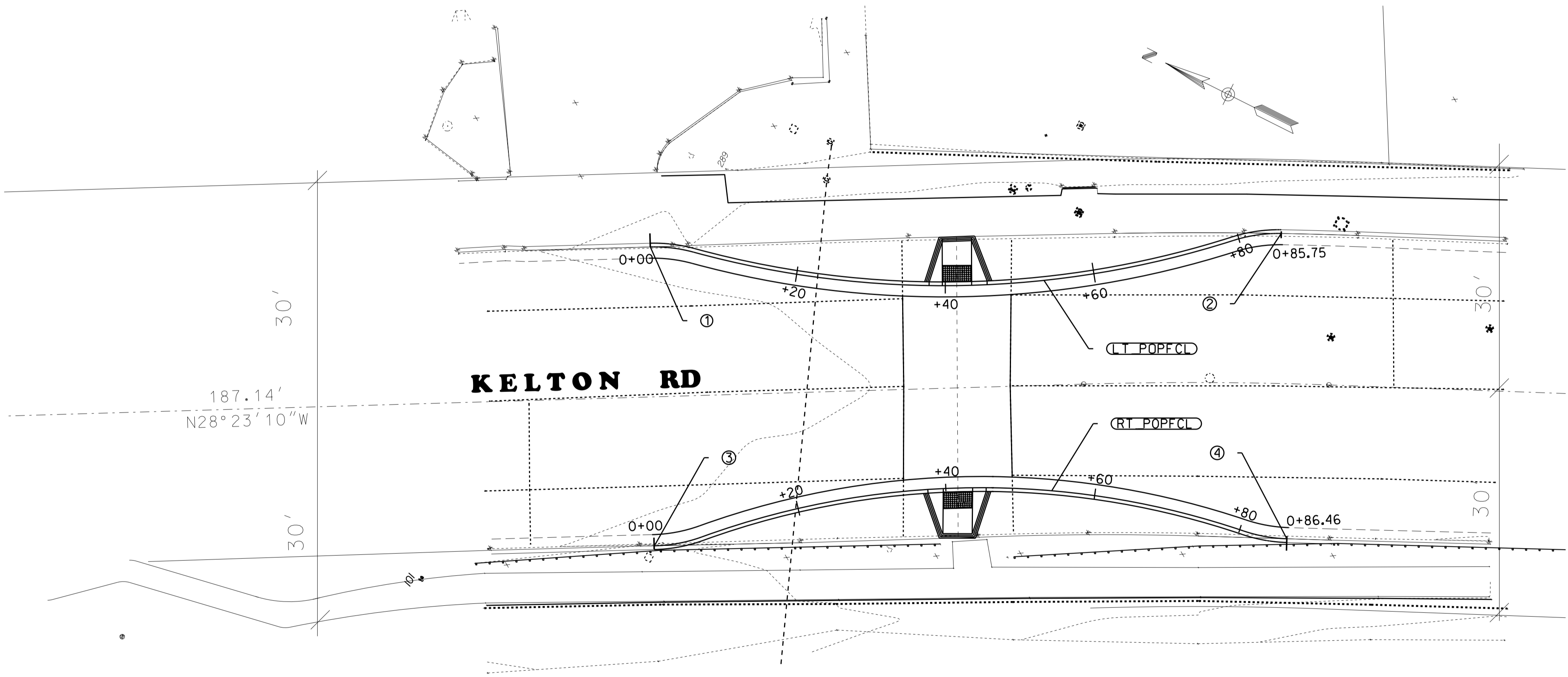

KELTON ROAD POPOUT CURB ALIGNMENTS LAYOUT AND PROFILE

KELTON ROAD POPOUT FACE OF CURB LEFT AND RIGHT ALIGNMENTS						
Number	Type	Point	Station	Northing	Easting	Radius Length Delta / Theta Rotation Direction
Alignment Name: LT_POFCL						
Description: LT FACE OF CURB KELTON POPOUT						
Style: cl.control						
①	PC	0+00.00	1842539.251	6307840.163		
	PI	0+02.96	1842536.646	6307841.562	20.00	5.87 16° 49' 00" Right
	CC	1842529.785	6307822.545			
	PRC	0+05.87	1842533.749	6307842.148		
	PI	0+43.58	1842496.785	6307849.621	127.32	73.33 32° 59' 50" Left
	CC	1842558.978	6307966.946			
	PRC	0+79.20	1842469.854	6307876.018		
	PI	0+82.50	1842467.491	6307878.334	20.00	6.56 18° 47' 08" Right
	CC	1842455.854	6307861.735			
	PT	0+85.75	1842464.509	6307879.766		
Alignment Name: RT_POFCL						
Description: RT FACE OF CURB KELTON POPOUT						
Style: cl.control						
③	PC	0+00.00	1842520.811	6307804.634		
	PI	0+03.31	1842517.890	6307806.180	20.00	6.55 18° 46' 12" Left
	CC	1842530.167	6307822.310			
	PRC	0+06.55	1842515.621	6307808.584		
	PI	0+45.02	1842489.222	6307836.561	109.59	73.99 38° 40' 55" Right
	CC	1842435.916	6307733.373			
	PRC	0+80.54	1842451.129	6307841.900		
	PI	0+83.52	1842448.177	6307842.314	20.00	5.92 16° 57' 07" Left
	CC	1842453.905	6307861.707			
	PT	0+86.46	1842445.474	6307843.570		

C-4

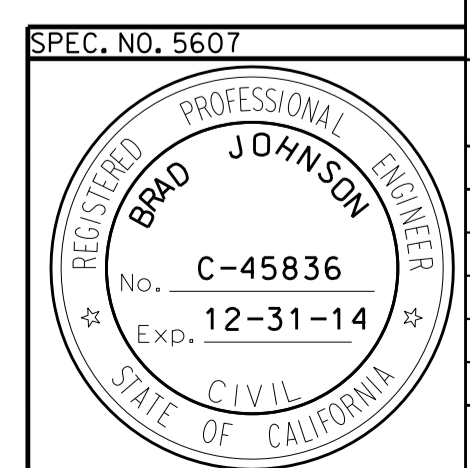
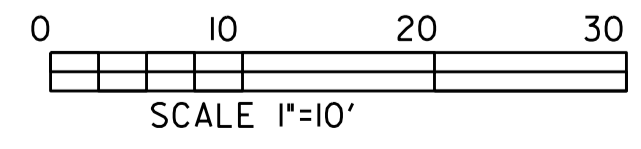

KELTON ROAD PEDESTRIAN IMPROVEMENT LAYOUT AND PROFILE			
CITY OF SAN DIEGO, CALIFORNIA ENGINEERING AND CAPITAL PROJECTS DEPARTMENT SHEET 4 OF 5 SHEETS			WBS S-10154
APPROVED BY <i>Brad Johnson</i>	DATE 2/12/2013	SUBMITTED BY LOUIS SCHULTZ ASSOCIATE ENGINEER	
FOR CITY ENGINEER		CHECKED BY SABEEN COCHINWAL PROJECT ENGINEER	
DESCRIPTION ORIGINAL	BY KZ	DATE	FILMED
No. C-45836		202-1743	
Exp. 12-31-14		1842444-6304407	
CONTRACTOR		DATE STARTED	36487- 04 -D
INSPECTOR		DATE COMPLETED	

CITY OF SAN DIEGO

LIGHTED PEDESTRIAN CROSSWALK ON KELTON ROAD

CONT'N OF GENERAL NOTES:

CONDUCTOR		TABLE				
AWG SIZE OR CABLE TYPE	POLE	CIRCUIT	CONDUIT SIZE & RUN			
			2"	2"	2"	4"
CONDUCTOR CABLE 7	A	LED SIGN + PPB	1	1	-	1
	B	LED SIGN + PPB	-	-	-	1
TOTAL 7 CONDUCTOR CABLES			1	1	-	2
CONDUCTORS #18		LED LIGHT FIXTURE	2	-	-	-
NO. 10		SERVICE	2	-	2	2
NO. 10		COMMON GROUND	1	1	1	1
NO. 10		LIGHTING	-	-	-	-
TOTAL CABLES AND CONDUCTORS			7	2	3	5

POLE		SCHEDULE						
No.	TYPE	STANDARD		LUMINAIRE CO-HPS	PLACEMENT		REMARKS	
		HGT.	SIG. M.A.		LUM. M.A.	A		B
④	TYPE I-A	12'	N/A	N/A	N/A	*	*	ADD LED SIGN AND PUSH BUTTON.
⑤	TYPE I-A	12'	N/A	N/A	N/A	*	*	ADD LED SIGN, PUSH BUTTON AND CONTROLLER

* TO BE LOCATED AND MARKED IN THE FIELD BY THE CITY RESIDENT ENGINEER.
 * PEDESTRIAN PUSH BUTTONS (PPB) SHALL CONFORM TO A.D.A. STANDARDS AND OPERATE WITH MANUFACTURERS COMPONENTS.

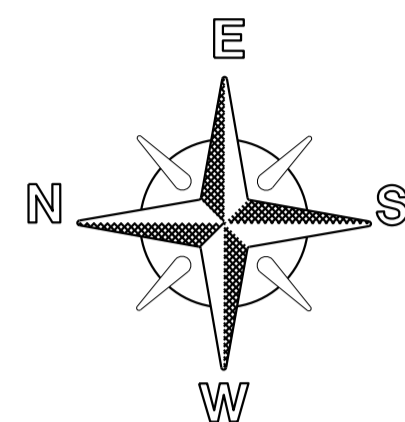

GENERAL NOTES:

- PULLBOXES AND CONDUIT:
 - PULLBOXES ARE No. 5, UNLESS OTHERWISE NOTED ON THIS PLAN.
 - ALL CONDUIT DEPTH MUST BE A MINIMUM OF 18" BELOW THE PAVEMENT SURFACE OR 3" BELOW THE BOTTOM OF THE PAVEMENT, WHICHEVER IS GREATER.
 - CONDUIT SHALL BE 2" DIAMETER, UNLESS OTHERWISE NOTED IN THE CONDUCTOR TABLE OR SHOWN ON THIS PLAN.
- LOCATIONS OF ALL UNDERGROUND UTILITIES ARE APPROXIMATE. THE CONTRACTOR SHALL DETERMINE THE EXACT LOCATIONS AND VERIFY ALL CONDITIONS ON THE JOB SITE.
- ALL POLE FOUNDATIONS SHALL HAVE A 2" CONDUIT INSTALLED TO AN ADJACENT No. 5 PULLBOX.

- LOCATION, POSITIONING, AND INSTALLATION OF ELECTRICAL EQUIPMENT, LIGHT FIXTURES, TRAFFIC SIGNS, TRAFFIC STRIPING, PAVEMENT AND CURB MARKINGS:
 - THE CONTRACTOR WITH THE APPROVAL OF THE CITY RESIDENT ENGINEER, IS RESPONSIBLE FOR LOCATING, MARKING THE LAYOUT, AND INSTALLATION OF ALL ELECTRICAL AND LIGHTING EQUIPMENT.
 - THE CONTRACTOR, WITH THE APPROVAL OF THE CITY'S DESIGNATED TRAFFIC ENGINEER, IS RESPONSIBLE FOR LOCATING, MARKING THE LAYOUT, AND INSTALLATION OF ALL LIGHTING FIXTURES, TRAFFIC SIGNS, TRAFFIC STRIPING, PAVEMENT AND CURB MARKINGS.
 - THE CONTRACTOR SHALL OBTAIN THE APPROVALS FOR THE ITEMS NOTED IN 5a AND 5b PRIOR TO INSTALLATION.
 - THE CONTRACTOR IS RESPONSIBLE FOR THE REMOVAL OF ALL CONFLICTING STRIPING AND PAVEMENT MARKINGS BY SANDBLASTING/GRINDING (METHOD TO BE DETERMINED BY THE CITY RESIDENT ENGINEER).
- CONTRACTOR SHALL RESTORE DISTURBED AREAS DUE TO CONSTRUCTION, BY MATCHING EXISTING SURROUNDING CONDITIONS.
- CONTRACTOR TO PROVIDE AND INSTALL ADEQUATE SOIL EROSION CONTROL MEASURES, TO THE APPROVAL OF THE CITY RESIDENT ENGINEER.
- CONTRACTOR TO DEVISE, DOCUMENT, AND UTILIZE A 'BEST MANAGEMENT' (BMP) PLAN, FOR WATER RUNOFF CONTROL, TO THE APPROVAL OF THE CITY RESIDENT ENGINEER.
- CONTRACTOR TO INSTALL COMPONENTS TO MANUFACTURER INSTRUCTIONS. WHERE CONFLICTS OCCUR BETWEEN THE INSTRUCTIONS AND THIS PLAN, THE CONTRACTOR SHALL BE DIRECTED BY THE CITY RESIDENT ENGINEER.

HENRY JOHNSON ELEMENTARY SCHOOL

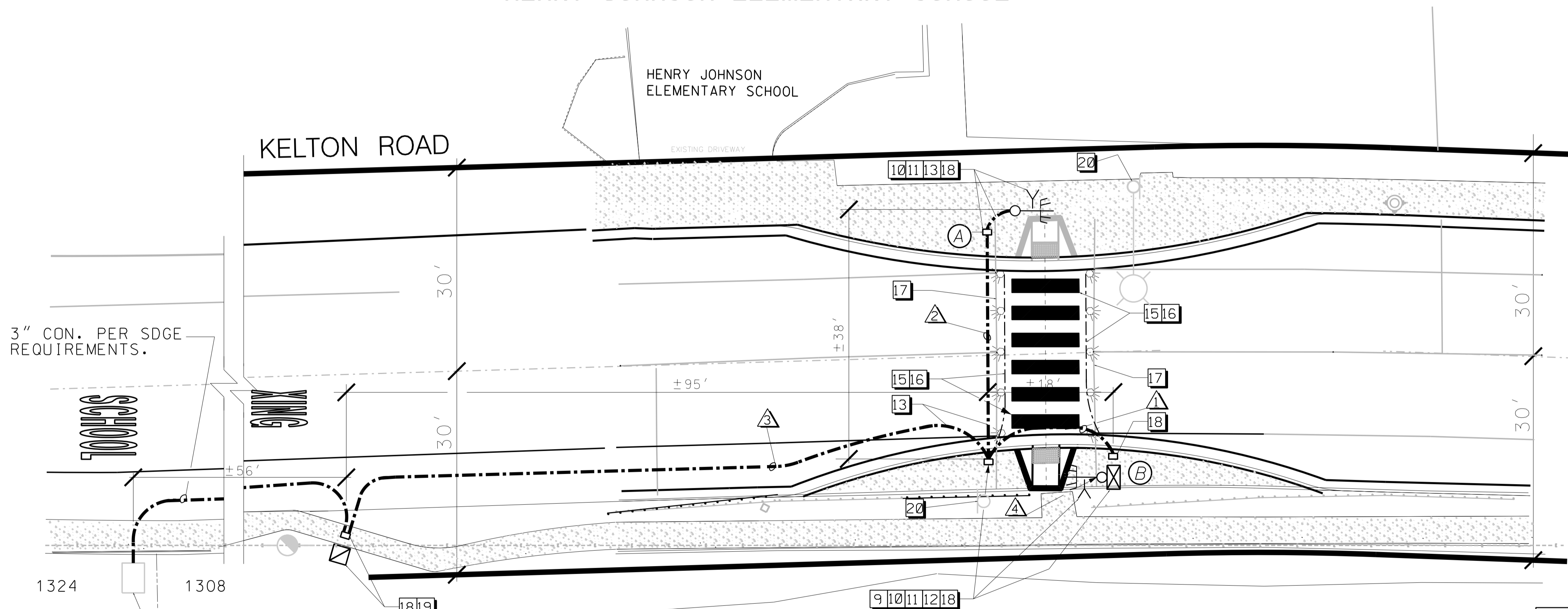

- FURNISH AND INSTALL LIGHTED CROSSWALK (LANELIGHT OR EQUAL) SYSTEM CONTROLLER CABINET PER MANUFACTURER'S REQUIREMENTS. ASSEMBLY SHALL BE WIRED FOR FULL LIGHTED CROSSWALK SYSTEM FUNCTIONALITY. ELECTRICAL CABINET SHALL INCLUDE ALL NECESSARY MOUNTING HARDWARE, WIRE PPB AND FLASHING WARNING SIGNS TO NEW CONTROLLER.
- INSTALL W16-7p AND S1-1 SCHOOL CROSSWALK SIGN WARNING ASSEMBLY.
- FURNISH AND INSTALL MUTCD APPROVED LED LIGHTED FLUORESCENT YELLOW GREEN S1-1 SIGN WITH BRACKETS. FURNISH AND INSTALL ALL NECESSARY ELECTRICAL COMPONENTS AND CONDUCTORS FOR PROPER OPERATION OF THE SIGN. PULL CONDUCTORS TO CONTROLLER AND LAND TO ASSIGNED TERMINALS. (SEE CONDUCTOR SCHEDULE)
- FURNISH & INSTALL ALL NECESSARY ELECTRICAL COMPONENTS, CONDUIT, AND CONDUCTORS TO CONTROLLER AND SERVICE CABINET, WHICH WILL FULLY OPERATE THE LIGHTING SYSTEM. PULL CONDUCTORS AND LAND TO APPROPRIATE TERMINALS. COORDINATE NEW METER AND SERVICE ACTIVATION WITH SDG&E (SEMPRA UTILITIES).
- FURNISH, TRENCH, AND INSTALL NEW ELECTRICAL CONDUIT WITH CONDUCTORS AS MARKED ON PLAN AND SHOWN IN CONDUCTOR TABLE.
- NOT USED.
- INSTALL YELLOW CROSSWALK STRIPING WITH 2' WIDE 2' SEPARATION BETWEEN STRIPES 30" WIDE AND IN ACCORDANCE WITH 2012 GREENBOOK SECTION 314-4.4. THERMOPLASTIC PAINT MATERIAL PER SECTION 214-5. (SEE DETAIL 1)
- FURNISH AND INSTALL LED PAVEMENT LIGHTING FIXTURES AND CONDUCTORS ADJACENT TO THE CROSSWALK LINES AND OUTSIDE THE PEDESTRIAN CROSSING AREA, AS SHOWN. INSTALLATION SHALL BE IN ACCORDANCE WITH THE MANUFACTURERS GUIDELINES/INSTRUCTIONS (UNLESS OTHERWISE DIRECTED BY THE CITY RESIDENT ENGINEER). LIGHT FIXTURES SHALL BE LOCATED SO AS TO AVOID TIRE TRACKING.
- REMOVE EXISTING LEGENDS, PAVEMENT MARKINGS, AND CONFLICTING STRIPING BY SANDBLASTING OR GRINDING METHOD APPROVED BY CITY RESIDENT ENGINEER.
- FURNISH AND INSTALL PER CALTRANS STANDARD #5 PULL BOX.
- INSTALL TYPE III SIGNAL AND LIGHT SERVICE PER STATE STANDARD PLAN ES-2D. PROVIDE 50A-1P CIRCUIT BREAKER FOR SIGNAL, 30A-1P (SEE SPECIAL PROVISIONS).
- REMOVE EXISTING S1-1 SCHOOL CROSSWALK SIGN WARNING ASSEMBLY.

LEGEND:

EXISTING CONDITIONS SHOWN IN LIGHTER HALF-TONE:
 PROPOSED IMPROVEMENTS SHOWN IN DARKER FULL-TONE:
 SALVAGED AND REUSED/RELOCATED EQUIPMENT SHOWN DASHED:

- CONTROLLER CABINET
- SERVICE METER, PEDESTAL, & FOUNDATION
- TRAFFIC SIGN
- ELECTRICAL PULLBOX / HAND HOLE
- EXISTING STREET LIGHT
- LED LIGHT FIXTURE

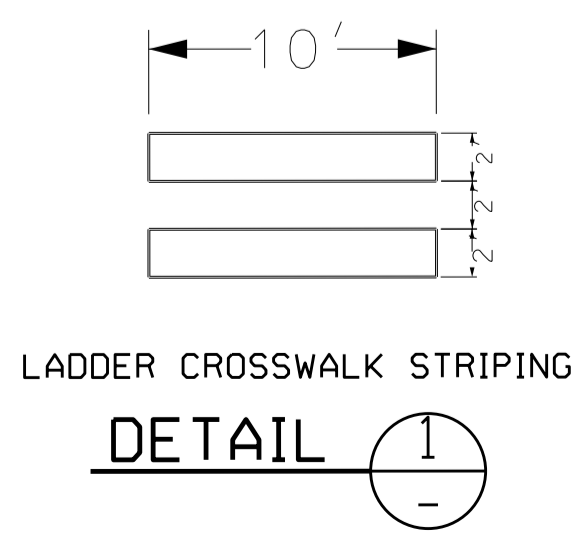

LEGEND (CONTINUED):

- PROPOSED CURB RAMP
- NEW ELECTRICAL CONDUIT WITH CONDUCTORS
- EXISTING ELECTRICAL CONDUIT WITH ADDED CONDUCTORS
- EXISTING ELECTRICAL OVERHEAD
- POLE WITH YELLOW LED LIGHTED SIGN

MUTCD SIGNS:

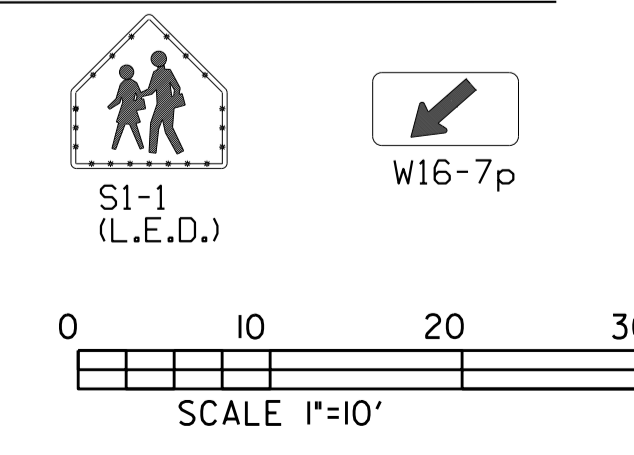

CITY OF SAN DIEGO
 [Signature] 7/27/2012
 TRAFFIC ENGINEER DATE

KELTON ROAD PEDESTRIAN IMPROVEMENT SIGNALS AND STRIPING

CITY OF SAN DIEGO, CALIFORNIA ENGINEERING AND CAPITAL PROJECTS DEPARTMENT SHEET 5 OF 5 SHEETS		WBS S-10154
FOR CITY ENGINEER	DATE 2/12/2013	DESIGNED BY F. LASAGA ASSOCIATE ENGINEER
DESCRIPTION ORIGINAL	BY RH	APPROVED DATE FILMED
CHECKED BY R. HURTADO PROJECT ENGINEER		NO. C-45836 Exp. 12-31-14
CONTRACTOR		DATE STARTED
INSPECTOR		DATE COMPLETED
		36487- 05 -D

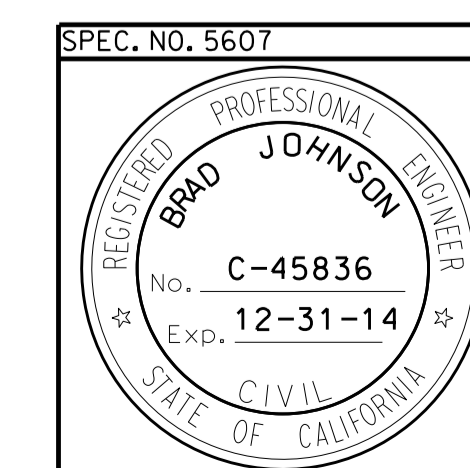

KELTON RD PED IMPROVEMENT T-1