

City of San Diego

CONTRACTOR'S NAME: _____
ADDRESS: _____
TELEPHONE NO.: _____ FAX NO.: _____
CITY CONTACT: Claudia Abarca - Contract Specialist, Email: Cabarca@sandiego.gov
Phone No. (619) 533-3439, Fax No. (619) 533-3633
G.Martedi / KA / LS

CONTRACT DOCUMENTS



FOR

FY'14 SIDEWALK REPLACEMENT GROUP 2

VOLUME 1 OF 2

BID NO.: _____ L-14-6115-DBB-2
SAP NO. (WBS/IO/CC): _____ B-14038
CLIENT DEPARTMENT: _____ 2116
COUNCIL DISTRICT: _____ CITYWIDE
PROJECT TYPE: _____ II / IJ

THIS CONTRACT IS SUBJECT TO THE FOLLOWING:

- THE CITY'S SUBCONTRACTING PARTICIPATION REQUIREMENTS FOR SLBE PROGRAM.
- COMPETITION RESTRICTED TO: SLBE-ELBE or ELBE FIRMS ONLY .
- PREVAILING WAGE RATES: STATE FEDERAL

BID DUE DATE:

**1:30 PM
FEBRUARY 26, 2014
CITY OF SAN DIEGO
PUBLIC WORKS CONTRACTING GROUP
1010 SECOND AVENUE, 14th FLOOR, MS 614C
SAN DIEGO, CA 92101**

ENGINEER OF WORK

The engineering Specifications and Special Provisions contained herein have been prepared by or under the direction of the following Registered Engineer:

Walter C. Gefrom III
For City Engineer

1/21/2014
Date

Seal



TABLE OF CONTENTS

DESCRIPTION	PAGE NUMBER
1. NOTICE INVITING BIDS.....	4
2. CONTRACT FORMS	16
3. CONTRACT FORMS ATTACHMENTS:	
1. Performance Bond and Labor and Materialmen’s Bond	19
2. Drug-Free Workplace.....	21
3. American with Disabilities Act (ADA) Compliance Certification	22
4. Contractor Standards - Pledge of Compliance Certificate	23
5. Affidavit of Disposal Certificate	24
4. ATTACHMENTS:	
A. SCOPE OF WORK	27
B. INTENTIONALLY LEFT BLANK.....	28
C. EQUAL OPPORTUNITY CONTRACTING PROGRAM	30
D. INTENTIONALLY LEFT BLANK.....	33
E. SUPPLEMENTARY SPECIAL PROVISIONS	35
SUPPLEMENTARY SPECIAL PROVISIONS APPENDICES:	
1. Appendix A -Fire Hydrant Meter Program	46
2. Appendix B - Materials Typically Accepted by Certificate of Compliance	60
3. Appendix C - Sample City Invoice	62
4. Appendix D –Tree Related Standard Drawings	64
5. Appendix E – Project Location List	70
6. Appendix F – Door Hanger	80
F. INTENTIONALLY LEFT BLANK.....	82

CITY OF SAN DIEGO, CALIFORNIA

NOTICE INVITING BIDS

1. **LIMITED COMPETITION:** This contract may only be bid by the Contractors on the City's approved SLBE-ELBE Construction Contractors List in accordance with the designation stated on the cover page hereof. For information regarding the SLBE-ELBE Construction Program and registration visit the City's web site: <http://www.sandiego.gov>.
2. **RECEIPT AND OPENING OF BIDS:** Bids will be received at the Public Works Contracting Group at the location, time, and date shown on the cover of these specifications for performing work on **FY'14 Sidewalk Replacement Group 2** (Project).
3. **SUMMARY OF WORK:** The Work involves furnishing all labor, materials, equipment, services, and other incidental works and appurtenances for the construction of the Project as described in ATTACHMENT A.
4. **BIDS ARE PUBLIC RECORDS:** Upon receipt by the City, Bids shall become public records subject to public disclosure. It is the responsibility of the respondent to clearly identify any confidential, proprietary, trade secret or otherwise legally privileged information contained within the Bid. General references to sections of the California Public Records Act (PRA) will not suffice. If the Contractor does not provide applicable case law that clearly establishes that the requested information is exempt from the disclosure requirements of the PRA, the City shall be free to release the information when required in accordance with the PRA, pursuant to any other applicable law, or by order of any court or government agency, and the Contractor will hold the City harmless for release of this information.
5. **EQUAL OPPORTUNITY CONTRACTING PROGRAM:**
 - 5.1. The City has incorporated voluntary subcontractor participation percentage to enhance competition and maximize subcontracting opportunities as follows.
 - 5.2. The following voluntary subcontractor participation percentage for DBE, DVBE, WBE, MBE, SLBE, and ELBE certified Subcontractors shall apply to this contract:

Total voluntary subcontractor participation percentage for this project is 14.4%.
 - 5.3. For additional Equal Opportunity Contracting Program requirements, see Attachment C.
6. **PRE-BID MEETING:**
 - 6.1. There will be a Pre-Bid Meeting to discuss the scope of the Project, bidding requirements, pre-qualification process, and Equal Opportunity Contracting Program requirements and reporting procedures in the Public Works Contracting Group, Conference Room at 1010 Second Avenue, 14th Floor, San Diego, CA 92101 at **10:00 A.M., FEBRUARY 4th, 2014**
 - 6.2. All potential bidders are encouraged to attend.

- 6.3. To request a copy of the agenda on an alternative format, or to request a sign language or oral interpreter for this meeting, call the Public Works Contracting Group at (619) 533-3450 at least 5 Working Days prior to the Pre-Bid Meeting to ensure availability.

7. **CONTRACTOR REGISTRATION AND ELECTRONIC REPORTING SYSTEM:**

- 7.1. **Prior** to the Award of the Contract or each Task Order, you and your Subcontractors and Suppliers must register with the City's web-based contract compliance website, Prism®, located here:

<https://pro.prismcompliance.com/default.aspx>.

- 7.2. The City may not award the contract until registration of all subcontractors and suppliers is complete. In the event this requirement is not met within the time frame specified in the Notice of Intent to Award letter, the City reserves the right to rescind the Notice of Award / Intent to Award and to make the award to the next responsive and responsible bidder / proposer.

8. **JOINT VENTURE CONTRACTORS:** Provide a copy of the Joint Venture agreement and the Joint Venture license to the City within 10 Working Days after receiving the Contract forms. See 2-1.1.2, "Joint Venture Contractors" in The WHITEBOOK for details.

9. **PREVAILING WAGE RATES:** Prevailing wage rates apply to this contract.

9.1. **STATE REQUIREMENTS FOR CONTRACTS SUBJECT TO STATE PREVAILING WAGE REQUIREMENTS.**

- 9.1.1. In accordance with the provisions of California Labor Code Sections 1770, et seq. as amended, the Director of the Department of Industrial Relations has determined the general prevailing rate of per diem wages in accordance with the standards set forth in such Sections for the locality in which the Work is to be performed. Copies of the prevailing rate of per diem wages may be found at http://www.dir.ca.gov/dlsr/statistics_research.html. The Contractor shall post a copy of the above determination of the prevailing rate of per diem wages at each job site and shall make them available to any interested party on request.

- 9.1.2. Pursuant to Sections 1720 et seq., and 1770 et seq., of the California Labor Code the Contractor any Subcontractor shall pay not less than said specified rates determined by the Director of the California Department of Industrial Relations to all workmen employed by them in the execution of the Work.

- 9.1.3. The wage rates determined by the Director of Industrial Relations and published in the Department of Transportation publication entitled, "General Prevailing Wage Rates", refer to expiration dates. If the published wage rate does not refer to a predetermined wage rate to be paid after the expiration date, said published rate of wage shall be in effect for the life of this contract. If the published wage rate refers to a predetermined wage rate to become effective upon expiration of the

published wage rate and the predetermined wage rate is on file with the Department of Industrial Relations, such predetermined wage rate shall become effective on the date following the expiration date and shall apply to this contract in the same manner as if it had been published in said publication. If the predetermined wage rate refers to one or more additional expiration dates with additional predetermined wage rates, which expiration dates occur during the life of this contract, each successive predetermined wage rate shall apply to this contract on the date following the expiration date of the previous wage rate. If the last of such predetermined wage rates expires during the life of this contract, such wage rate shall apply to the balance of the contract.

- 9.1.4.** The successful bidder intending to use a craft or classification not shown on the prevailing rate determinations may be required to pay the rate of the craft or classification most closely related to it.

10. INSURANCE REQUIREMENTS:

- 10.1.** All certificates of insurance and endorsements required by the contract are to be provided upon issuance of the City's Notice of Intent to Award letter.
- 10.2.** Refer to sections 7-3, "LIABILITY INSURANCE", and 7-4, "WORKERS' COMPENSATION INSURANCE" of the Supplementary Special Provisions (SSP) for the insurance requirements which must be met.

11. PREQUALIFICATION OF CONTRACTORS:

- 11.1.** Contractors submitting Bid must be pre-qualified for the total amount proposed, inclusive of all alternate items prior to the date of submittal. Bids from contractors who have not been pre-qualified as applicable and Bids that exceed the maximum dollar amount at which contractors are pre-qualified will be deemed **non-responsive** and ineligible for award. Complete information and prequalification questionnaires are available at:

<http://www.sandiego.gov/cip/bidopps/prequalification.shtml>

- 11.2.** The completed questionnaire, financial statement, and bond letter or a copy of the contractor's SLBE-ELBE certification and bond letter, must be submitted no later than 2 weeks prior to the bid opening to the Public Works Contracting Group, Prequalification Program, 1010 Second Avenue, 14th Floor, San Diego, CA 92101. For additional information or the answer to questions about the prequalification program, contact David Stucky at 619-533-3474 or dstucky@sandiego.gov.

- 12. REFERENCE STANDARDS:** Except as otherwise noted or specified, the Work shall be completed in accordance with the following standards:

Title	Edition	Document Number
Standard Specifications for Public Works Construction (“The GREENBOOK”)	2012	PITS070112-01
City of San Diego Standard Specifications for Public Works Construction (“The WHITEBOOK”)*	2012	PITS070112-02
City of San Diego Standard Drawings*	2012	PITS070112-03
Caltrans Standard Specifications	2010	PITS070112-04
Caltrans Standard Plans	2010	PITS070112-05
California MUTCD	2012	PITS070112-06
City Standard Drawings - Updates Approved For Use (when specified)*	Varies	Varies
Standard Federal Equal Employment Opportunity Construction Contract Specifications and the Equal Opportunity Clause Dated 09-11-84	1984	769023
NOTE: * Available online under Engineering Documents and References at: http://www.sandiego.gov/publicworks/edocref/index.shtml		

13. **CITY’S RESPONSES AND ADDENDA:** The City at its option, may respond to any or all questions submitted in writing, via letter, or FAX in the form of an addendum. No oral comment shall be of any force or effect with respect to this solicitation. The changes to the Contract Documents through addendum are made effective as though originally issued with the Bid. The Bidders shall acknowledge the receipt of Addenda on the form provided for this purpose in the Bid.
14. **CITY’S RIGHTS RESERVED:** The City reserves the right to cancel the Notice Inviting Bids at any time, and further reserves the right to reject submitted Bids, without giving any reason for such action, at its sole discretion and without liability. Costs incurred by the Bidder(s) as a result of preparing Bids under the Notice Inviting Bids shall be the sole responsibility of each bidder. The Notice Inviting Bids creates or imposes no obligation upon the City to enter a contract.
15. **CONTRACT PRICING FORMAT:** This solicitation is for a Lump Sum contract with Unit Price provisions as set forth in the Bid Proposal Form(s), Volume 2.
16. **SUBMITTAL OF “OR EQUAL” ITEMS:** See Section 4-1.6, “Trade Names or Equals” in The WHITEBOOK and as amended in the SSP.
17. **AWARD PROCESS:**
 - 17.1. The Award of this contract is contingent upon the Contractor’s compliance with all conditions precedent to Award.
 - 17.2. Upon acceptance of a Bid, the City will prepare contract documents for execution within approximately 21 days of the date of the Bid opening and award the Contract

approximately within 7 days of receipt of properly executed Contract, bonds, and insurance documents.

- 17.3.** This contract will be deemed executed, and effective, only upon the signing of the Contract by the Mayor or designee of the City.
- 18. SUBCONTRACT LIMITATIONS:** The Bidder's attention is directed to Standard Specifications for Public Works Construction, Section 2-3, "SUBCONTRACTS" in The GREENBOOK and as amended in the SSP which requires the Contractor to self perform the amount therein stipulated. Failure to comply with these requirements may render the Bid **non-responsive** and ineligible for award.
- 19. AVAILABILITY OF PLANS AND SPECIFICATIONS:** Contract Documents may be obtained by visiting the City's website: <http://www.sandiego.gov/cip/>. Plans and Specifications for this contract are also available for review in the office of the City Clerk or Public Works Contracting Group.
- 20. SUBMISSION OF QUESTIONS:**
- 20.1.** The Director (or designee), of the Public Works Department is the officer responsible for opening, examining, and evaluating the competitive Bids submitted to the City for the acquisition, construction and completion of any public improvement except when otherwise set forth in these documents. All questions related to this solicitation shall be submitted to:
- Public Works Contracting Group
1010 Second Avenue, 14th Floor
San Diego, California, 92101
- Attention: [Contract Specialist listed on the front cover hereof]
- OR:
- Email address of the Contract Specialist listed on the front cover hereof.
- 20.2.** Questions received less than 14 days prior to the date for opening of Bids may not be considered.
- 20.3.** Clarifications deemed by the City to be material shall be issued by Addenda and uploaded to the City's online bidding service.
- 20.4.** Only questions answered by formal written addenda will be binding. Oral and other interpretations or clarifications will be without legal effect. It is the Bidder's responsibility to become informed of any Addenda that have been issued and to include all such information in its Bid.
- 21. ELIGIBLE BIDDERS:** No person, firm, or corporation shall be allowed to make, file, or be interested in **more** than one (1) Bid for the same work unless alternate Bids are called for. A person, firm or corporation who has submitted a sub-proposal to a Bidder, or who has quoted prices on materials to a Bidder, is not hereby disqualified from submitting a sub-proposal or

quoting prices to other Bidders or from submitting a Bid in its own behalf. Any Bidder who submits more than one bid will result in the rejection of all bids submitted.

22. SAN DIEGO BUSINESS TAX CERTIFICATE: The Contractor and Subcontractors, not already having a City of San Diego Business Tax Certificate for the work contemplated shall secure the appropriate certificate from the City Treasurer, Civic Center Plaza, first floor and submit to the Contract Specialist upon request or as specified in the Contract Documents. Tax Identification numbers for both the Bidder and the listed Subcontractors must be submitted on the City provided forms with the Notice Inviting Bids and Contract forms.

23. PROPOSAL FORMS: Bid shall be made only upon the Bidding Documents i.e., Proposal form attached to and forming a part of the specifications. The signature of each person signing shall be in longhand.

23.1. Bidder shall complete and submit all pages in the "Bidding Document" Section (see Volume 2) as their Bid per the schedule given under "Required Documents Schedule," (see Volume 1). Bidder is requested to retain for their reference other portions of the Contract Documents that are not required to be submitted with the Bid. The entire specifications for the bid package do not need to be submitted with the bid.

23.2. The City may require any Bidder to furnish a statement of experience, financial responsibility, technical ability, equipment, and references.

23.3. Bids and certain other forms and documents as specified in the Volume 2 of 2 of the Contract Documents shall be enclosed in a sealed envelope and shall bear the title of the work and name of the Bidder and the appropriate State Contractors License designation which the Bidder holds.

23.4. Bids may be withdrawn by the Bidder prior to, but not after, the time fixed for opening of Bids.

24. BIDDER'S GUARANTEE OF GOOD FAITH (BID SECURITY):

24.1. With the exception of the contracts valued \$5,000 or less, JOC and Design-Build contracts, and contracts subject to the Small and Local Business Program of \$250,000 or less e.g., ELBE contracts, each Bidder shall accompany its Bid with either a cashier's check upon some responsible bank, or a check upon such bank properly certified or an approved corporate surety bond payable to the City of San Diego, for an amount of not less than 10% of the aggregate sum of the Bid, which check or bond, and the monies represented thereby shall be held by the City as a guarantee that the Bidder, if awarded the contract, will in good faith enter into such contract and furnish the required final bonds.

24.2. The Bidder agrees that in case of Bidder's refusal or failure to execute this contract and give required final bonds, the money represented by a cashier's or certified check shall remain the property of the City, and if the Bidder shall fail to execute this contract, the Surety agrees that it will pay to the City damages which the City may suffer by reason of such failure, not exceeding the sum of 10% of the amount of the Bid.

24.3. A Bid received without the specified bid security will be rejected as being **non-responsive**.

25. AWARD OF CONTRACT OR REJECTION OF BIDS:

25.1. This contract may be awarded to the lowest responsible and reliable Bidder.

25.2. Bidders shall complete the entire Bid schedule (also referred to as “schedule of prices” or Proposal form). Incomplete price schedules will be rejected as being non-responsive.

25.3. The City reserves the right to reject any or all Bids, and to waive any informality or technicality in Bids received and any requirements of these specifications as to bidding procedure.

25.4. Bidders will not be released on account of their errors of judgment. Bidders may be released only upon receipt by the City from the Bidder within 3 Working Days, excluding Saturdays, Sundays, and state holidays, after the opening of Bids, of written notice which includes proof of honest, credible, clerical error of material nature, free from fraud or fraudulent intent, and of evidence that reasonable care was observed in the preparation of the Bid.

25.5. A non-selected Bidder may protest award of the Contract to the selected Bidder by submitting a written “Notice of Intent to Protest” including supporting documentation which shall be received by Public Works Contracting Group no later than 10 days after the City’s announcement of the selected Bidder or no later than 10 days from the date that the City issues notice of designation of a Bidder as non-responsive in accordance with San Diego Municipal Code Chapter 2, § 22.3029, “Protests of Contract Award.”

25.6. The City of San Diego will not discriminate with regard to race, religious creed, color, national origin, ancestry, physical handicap, marital status, sex or age, in the award of contracts.

25.7. Each Bid package properly executed as required by these specifications shall constitute a firm offer, which may be accepted by the City within the time specified in the Proposal.

25.8. The City reserves the right to evaluate all Bids and determine the lowest Bidder on the basis of any proposed alternates, additive items or options, at its discretion that will be disclosed in the Volume 2 of 2.

26. BID RESULTS:

- 26.1.** The Bid opening by the City shall constitute the public announcement of the Apparent Low Bidder. In the event that the Apparent Low Bidder is subsequently deemed non-responsive or non-responsible, a public announcement will be posted in the City's web page <http://www.sandiego.gov/cip/index.shtml>, with the name of the newly designated Apparent Low Bidder.
- 26.2.** To obtain Bid results, either attend Bid opening, review the results on the City's web site, or provide a self-addressed, stamped envelope, referencing Bid number, and Bid tabulation will be mailed to you upon verification of extensions. Bid results cannot be given over the telephone.

27. THE CONTRACT:

- 27.1.** The Bidder to whom award is made shall execute a written contract with the City of San Diego and furnish good and approved bonds and insurance certificates specified by the City within 14 days after receipt by Bidder of a form of contract for execution unless an extension of time is granted to the Bidder in writing.
- 27.2.** If the Bidder takes longer than 14 days to fulfill these requirements, then the additional time taken shall be added to the Bid guarantee. The Contract shall be made in the form adopted by the City, which includes the provision that no claim or suit whatsoever shall be made or brought by Contractor against any officer, agent, or employee of the City for or on account of anything done or omitted to be done in connection with this contract, nor shall any such officer, agent, or employee be liable hereunder.
- 27.3.** If the Bidder to whom the award is made fails to enter into the contract as herein provided, the award may be annulled and the Bidder's Guarantee of Good Faith will be subject to forfeiture. An award may be made to the next lowest responsible and reliable Bidder who shall fulfill every stipulation embraced herein as if it were the party to whom the first award was made.
- 27.4.** Pursuant to the San Diego City Charter section 94, the City may only award a public works contract to the lowest responsible and reliable Bidder. The City will require the Apparent Low Bidder to (i) submit information to determine the Bidder's responsibility and reliability, (ii) execute the Contract in form provided by the City, and (iii) furnish good and approved bonds and insurance certificates specified by the City within 14 Days, unless otherwise approved by the City, in writing after the Bidder receives notification from the City, designating the Bidder as the Apparent Low Bidder and formally requesting the above mentioned items.
- 27.5.** The award of the Contract is contingent upon the satisfactory completion of the above mentioned items and becomes effective upon the signing of the Contract by the Mayor or designee. If the Apparent Low Bidder does not execute the Contract or submit required documents and information, the City may award the Contract to the next lowest responsible and reliable Bidder who shall fulfill every condition precedent to award. A corporation designated as the Apparent Low Bidder shall furnish evidence of its corporate existence and evidence that the officer signing the Contract and bond for the corporation is duly authorized to do so.

- 28. EXAMINATION OF PLANS, SPECIFICATIONS, AND SITE OF WORK:** The Bidder shall examine carefully the Project Site, the Plans and Specifications, other materials as described in the Special Provisions, Section 2-7, and the proposal forms (e.g., Bidding Documents). The submission of a Bid shall be conclusive evidence that the Bidder has investigated and is satisfied as to the conditions to be encountered, as to the character, quality, and scope of Work, the quantities of materials to be furnished, and as to the requirements of the Bidding Documents Proposal, Plans, and Specifications.
- 29. CITY STANDARD PROVISIONS:** This contract is subject to the following standard provisions. See The WHITEBOOK for details.
- 29.1.** The City of San Diego Resolution No. R-277952 adopted on May 20, 1991 for a Drug-Free Workplace.
- 29.2.** The City of San Diego Resolution No. R-282153 adopted on June 14, 1993 related to the Americans with Disabilities Act.
- 29.3.** The City of San Diego Municipal Code §22.3004 for Pledge of Compliance.
- 29.4.** The City of San Diego’s Labor Compliance Program and the State of California Labor Code §§1771.5(b) and 1776.
- 29.5.** Sections 1777.5, 1777.6, and 1777.7 of the State of California Labor Code concerning the employment of apprentices by contractors and subcontractors performing public works contracts.
- 29.6.** The City’s Equal Benefits Ordinance (EBO), Chapter 2, Article 2, Division 43 of The San Diego Municipal Code (SDMC).
- 29.7.** The City’s Information Security Policy (ISP) as defined in the City’s Administrative Regulation 90.63.
- 30. PRE-AWARD ACTIVITIES:**
- 30.1.** The selected contractor by the City to execute a contract for this Work shall provide the information required within the time specified in “Required Documents,” of this bid package. Failure to provide the information within the time specified may result in the Bid being rejected as **non-responsive**.
- 30.2.** If the Bid is rejected as non-responsive, the selected contractor by the City to execute a contract for this Work shall forfeit the required Bid. The decision that the selected contractor by the City to execute a contract for this Work is non-responsive for failure to provide the information required within the time specified shall be at the sole discretion of the City.
- 31. REQUIRED DOCUMENT SCHEDULE:**
- 31.1.** The Bidder’s attention is directed to the City’s Municipal Code §22.0807(e), (3)-(5) for important information regarding grounds for debarment for failure to submit required documentation.

31.2. The specified Equal Opportunity Contracting Program (EOCP) forms are available for download from the City's web site at:

<http://www.sandiego.gov/eoc/forms/index.shtml>

ITEM	WHEN DUE	FROM	DOCUMENT TO BE SUBMITTED
1.	BID SUBMITTAL DATE/TIME	ALL BIDDERS	Bid
2.	BID SUBMITTAL DATE/TIME	ALL BIDDERS	Bid Bond
3.	BID SUBMITTAL DATE/TIME	ALL BIDDERS	Non-collusion Affidavit to be Executed By Bidder and Submitted with Bid under 23 USC 112 and PCC 7106
4.	BID SUBMITTAL DATE/TIME	ALL BIDDERS	Contractors Certification of Pending Actions
5.	BID SUBMITTAL DATE/TIME	ALL BIDDERS	Equal Benefits Ordinance Certification of Compliance
6.	BID SUBMITTAL DATE/TIME	ALL BIDDERS	Form AA35 - List of Subcontractors
7.	BID SUBMITTAL DATE/TIME	ALL BIDDERS	Form AA40 - Named Equipment/Material Supplier List
8.	WITHIN 10 WORKING DAYS AFTER RECEIPT BY BIDDER OF CONTRACT FORMS	APPARENT LOW BIDDER	Names of the principal individual owners of the Apparent Low Bidder
9.	WITHIN 10 WORKING DAYS AFTER RECEIPT BY BIDDER OF CONTRACT FORMS	APPARENT LOW BIDDER	If the Contractor is a Joint Venture: <ul style="list-style-type: none"> • Joint Venture Agreement • Joint Venture License
10.	WITHIN 10 WORKING DAYS AFTER RECEIPT BY BIDDER OF CONTRACT FORMS	APPARENT LOW BIDDER	Form BB05 - Work Force Report
11.	WITHIN 10 WORKING DAYS AFTER RECEIPT BY BIDDER OF CONTRACT FORMS	APPARENT LOW BIDDER	Contract Forms - Agreement
12.	WITHIN 10 WORKING DAYS AFTER RECEIPT BY BIDDER OF CONTRACT FORMS	APPARENT LOW BIDDER	Contract Forms - Payment and Performance Bond
13.	WITHIN 10 WORKING DAYS AFTER RECEIPT BY BIDDER OF CONTRACT FORMS	APPARENT LOW BIDDER	Certificates of Insurance and Endorsements

ITEM	WHEN DUE	FROM	DOCUMENT TO BE SUBMITTED
14.	WITHIN 10 WORKING DAYS AFTER RECEIPT BY BIDDER OF CONTRACT FORMS	APPARENT LOW BIDDER	Contractor Certification - Drug-Free Workplace
15.	WITHIN 10 WORKING DAYS AFTER RECEIPT BY BIDDER OF CONTRACT FORMS	APPARENT LOW BIDDER	Contractor Certification - American with Disabilities Act
16.	WITHIN 10 WORKING DAYS AFTER RECEIPT BY BIDDER OF CONTRACT FORMS	APPARENT LOW BIDDER	Contractors Standards - Pledge of Compliance

CONTRACT FORMS
AGREEMENT

CONTRACT FORMS

CONSTRUCTION CONTRACT

This contract is made and entered into between THE CITY OF SAN DIEGO, a municipal corporation, herein called "City", and PAL GENERAL ENGINEERING, INC., herein called "Contractor" for construction of FY'14 Sidewalk Replacement Group 2; Bid No. L-14-6115-DBB-2; in the amount of THREE HUNDRED EIGHTY THREE THOUSAND FOUR HUNDRED FIFTEEN DOLLARS AND ZERO CENTS (\$383,415.00), which is comprised of the Base Bid alone.

IN CONSIDERATION of the payments to be made hereunder and the mutual undertakings of the parties hereto, City and Contractor agree as follows:

1. The following are incorporated into this contract as though fully set forth herein:
 - (a) The attached Faithful Performance and Payment Bonds.
 - (b) The attached Proposal included in the Bid documents by the Contractor.
 - (c) Reference Standards listed in the Notice Inviting Bids and the Supplementary Special Provisions (SSP).
 - (d) That certain documents entitled FY'14 Sidewalk Replacement Group 2, on file in the office of the Public Works Department as Document No. B-14038, as well as all matters referenced therein.
2. The Contractor shall perform and be bound by all the terms and conditions of this contract and in strict conformity therewith shall perform and complete in a good and workmanlike manner FY'14 Sidewalk Replacement Group 2, Bid Number L-14-6115-DBB-2, San Diego, California.
3. For such performances, the City shall pay to Contractor the amounts set forth at the times and in the manner and with such additions or deductions as are provided for in this contract, and the Contractor shall accept such payment in full satisfaction of all claims incident to such performances.
4. No claim or suit whatsoever shall be made or brought by Contractor against any officer, agent, or employee of the City for or on account of anything done or omitted to be done in connection with this contract, nor shall any such officer, agent, or employee be liable hereunder.
5. This contract is effective as of the date that the Mayor or designee signs the agreement.

CONTRACT FORMS (continued)

IN WITNESS WHEREOF, this Agreement is signed by the City of San Diego, acting by and through its Mayor or designee, pursuant to Municipal Code §21.3102(d) authorizing such execution.

THE CITY OF SAN DIEGO

APPROVED AS TO FORM AND LEGALITY

By 

Jan I. Goldsmith, City Attorney

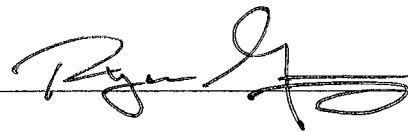
By 

Print Name: Stephen Samara
Senior Contract Specialist

Print Name: RYAN P GERRITY
Deputy City Attorney

Date: 4/10/14

Date: 4/9/14

CONTRACTOR

By 

Print Name: Marla Jahshan

Title: President

Date: March 11, 2014

City of San Diego License No.: 132008032175

State Contractor's License No.: 916931

**CONTRACT FORMS
ATTACHMENTS**

CONTRACT FORMS ATTACHMENTS
PERFORMANCE BOND AND LABOR AND MATERIALMEN'S BOND

FAITHFUL PERFORMANCE BOND AND LABOR AND MATERIALMEN'S BOND:

PAL GENERAL ENGINEERING, INC., a corporation, as principal, and The Hanover Insurance Company, a corporation authorized to do business in the State of California, as Surety, hereby obligate themselves, their successors and assigns, jointly and severally, to The City of San Diego a municipal corporation in the sum of THREE HUNDRED EIGHTY THREE THOUSAND FOUR HUNDRED FIFTEEN DOLLARS AND ZERO CENTS (\$383,415.00) for the faithful performance of the annexed contract, and in the sum of THREE HUNDRED EIGHTY THREE THOUSAND FOUR HUNDRED FIFTEEN DOLLARS AND ZERO CENTS (\$383,415.00) for the benefit of laborers and materialmen designated below.

Conditions:

If the Principal shall faithfully perform the annexed contract **FY'14 Sidewalk Replacement Group 2**, Bid Number **L-14-6115-DBB-2**, San Diego, California then the obligation herein with respect to a faithful performance shall be void; otherwise it shall remain in full force.

If the Principal shall promptly pay all persons, firms and corporations furnishing materials for or performing labor in the execution of this contract, and shall pay all amounts due under the California Unemployment Insurance Act then the obligation herein with respect to laborers and materialmen shall be void; otherwise it shall remain in full force.

The obligation herein with respect to laborers and materialmen shall inure to the benefit of all persons, firms and corporations entitled to file claims under the provisions of Chapter 3 of Division 5 of Title I of the Government Code of the State of California or under the provisions of Section 3082 et seq. of the Civil Code of the State of California.

Changes in the terms of the annexed contract or specifications accompanying same or referred to therein shall not affect the Surety's obligation on this bond, and the Surety hereby waives notice of same.

CONTRACT FORMS ATTACHMENTS (continued)
PERFORMANCE BOND AND LABOR AND MATERIALMEN'S BOND

The Surety shall pay reasonable attorney's fees should suit be brought to enforce the provisions of this bond.

Dated March 11, 2014

Approved as to Form and Legality

PAL General Engineering, Inc.

Principal

By

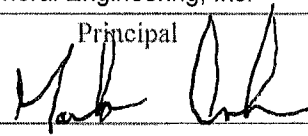

Marla Jahshan, President

Printed Name of Person Signing for Principal

Jan I. Goldsmith, City Attorney

By

Deputy City Attorney

The Hanover Insurance Company

Surety

By

Attorney-in-fact
Daniel Frazee

5 Hutton Centre, Suite 1060

Local Address of Surety

Santa Ana, CA 92707

Local Address (City, State) of Surety

714-415-3800

Local Telephone No. of Surety

Premium \$ 4,371

Bond No. 1025703

Approved:

By

Stephen Samara
Senior Contract Specialist

THE HANOVER INSURANCE COMPANY
MASSACHUSETTS BAY INSURANCE COMPANY
CITIZENS INSURANCE COMPANY OF AMERICA

POWERS OF ATTORNEY
CERTIFIED COPY

KNOW ALL MEN BY THESE PRESENTS: That THE HANOVER INSURANCE COMPANY and MASSACHUSETTS BAY INSURANCE COMPANY, both being corporations organized and existing under the laws of the State of New Hampshire, and CITIZENS INSURANCE COMPANY OF AMERICA, a corporation organized and existing under the laws of the State of Michigan, do hereby constitute and appoint

Matthew C. Gaynor, Kim D. Vasquez, Daniel Frazee and/or David J. Garcia

of **Santee, CA** and each is a true and lawful Attorney(s)-in-fact to sign, execute, seal, acknowledge and deliver for, and on its behalf, and as its act and deed any place within the United States, or, if the following line be filled in, only within the area therein designated any and all bonds, recognizances, undertakings, contracts of indemnity or other writings obligatory in the nature thereof, as follows:

Any such obligations in the United States, not to exceed Ten Million and No/100 (\$10,000,000) in any single instance

and said companies hereby ratify and confirm all and whatsoever said Attorney(s)-in-fact may lawfully do in the premises by virtue of these presents. These appointments are made under and by authority of the following Resolution passed by the Board of Directors of said Companies which resolutions are still in effect:

"RESOLVED, That the President or any Vice President, in conjunction with any Vice President, be and they are hereby authorized and empowered to appoint Attorneys-in-fact of the Company, in its name and as its acts, to execute and acknowledge for and on its behalf as Surety any and all bonds, recognizances, contracts of indemnity, waivers of citation and all other writings obligatory in the nature thereof, with power to attach thereto the seal of the Company. Any such writings so executed by such Attorneys-in-fact shall be as binding upon the Company as if they had been duly executed and acknowledged by the regularly elected officers of the Company in their own proper persons." (Adopted October 7, 1981 - The Hanover Insurance Company; Adopted April 14, 1982 - Massachusetts Bay Insurance Company; Adopted September 7, 2001 - Citizens Insurance Company of America)

IN WITNESS WHEREOF, THE HANOVER INSURANCE COMPANY, MASSACHUSETTS BAY INSURANCE COMPANY and CITIZENS INSURANCE COMPANY OF AMERICA have caused these presents to be sealed with their respective corporate seals, duly attested by two Vice Presidents, this **7th** day of **December 2011**.



THE HANOVER INSURANCE COMPANY
MASSACHUSETTS BAY INSURANCE COMPANY
CITIZENS INSURANCE COMPANY OF AMERICA

Robert Thomas, Vice President

Joe Brenstrom, Vice President

THE COMMONWEALTH OF MASSACHUSETTS)
COUNTY OF WORCESTER) ss.

On this **7th** day of **December 2011** before me came the above named Vice Presidents of The Hanover Insurance Company, Massachusetts Bay Insurance Company and Citizens Insurance Company of America, to me personally known to be the individuals and officers described herein, and acknowledged that the seals affixed to the preceding instrument are the corporate seals of The Hanover Insurance Company, Massachusetts Bay Insurance Company and Citizens Insurance Company of America, respectively, and that the said corporate seals and their signatures as officers were duly affixed and subscribed to said instrument by the authority and direction of said Corporations.



BARBARA A. GARLICK
Notary Public
Commonwealth of Massachusetts
My Commission Expires Sept. 21, 2018

Barbara A. Garlick, Notary Public
My Commission Expires September 21, 2018

I, the undersigned Vice President of The Hanover Insurance Company, Massachusetts Bay Insurance Company and Citizens Insurance Company of America, hereby certify that the above and foregoing is a full, true and correct copy of the Original Power of Attorney issued by said Companies, and do hereby further certify that the said Powers of Attorney are still in force and effect.

This Certificate may be signed by facsimile under and by authority of the following resolution of the Board of Directors of The Hanover Insurance Company, Massachusetts Bay Insurance Company and Citizens Insurance Company of America.

"RESOLVED, That any and all Powers of Attorney and Certified Copies of such Powers of Attorney and certification in respect thereto, granted and executed by the President or any Vice President in conjunction with any Vice President of the Company, shall be binding on the Company to the same extent as if all signatures therein were manually affixed, even though one or more of any such signatures thereon may be facsimile." (Adopted October 7, 1981 - The Hanover Insurance Company; Adopted April 14, 1982 - Massachusetts Bay Insurance Company; Adopted September 7, 2001 - Citizens Insurance Company of America)

GIVEN under my hand and the seals of said Companies, at Worcester, Massachusetts, this 11th day of March 2014.

THE HANOVER INSURANCE COMPANY
MASSACHUSETTS BAY INSURANCE COMPANY
CITIZENS INSURANCE COMPANY OF AMERICA

Glenn Margosian, Vice President

ACKNOWLEDGMENT

State of California
County of San Diego)

On March 11, 2014 before me, Kathy Scheuerman, Notary Public
(insert name and title of the officer)

personally appeared Daniel Frazee,
who proved to me on the basis of satisfactory evidence to be the person(s) whose name(s) is/are
subscribed to the within instrument and acknowledged to me that he/~~she~~/they executed the same in
his/~~her~~/their authorized capacity(ies), and that by his/~~her~~/their signature(s) on the instrument the
person(s), or the entity upon behalf of which the person(s) acted, executed the instrument.

I certify under PENALTY OF PERJURY under the laws of the State of California that the foregoing
paragraph is true and correct.

WITNESS my hand and official seal.



Signature Kathy Scheuerman (Seal)

CONTRACTOR CERTIFICATION

DRUG-FREE WORKPLACE

PROJECT TITLE: FY'14 Sidewalk Replacement Group 2

I hereby certify that I am familiar with the requirements of San Diego City Council Policy No. 100-17 regarding Drug-Free Workplace as outlined in the WHITEBOOK, Section 7-13.3, "Drug-Free Workplace", of the project specifications, and that;

PAL General Engineering, Inc.
(Name under which business is conducted)

has in place a drug-free workplace program that complies with said policy. I further certify that each subcontract agreement for this project contains language which indicates the subcontractor's agreement to abide by the provisions of subdivisions a) through c) of the policy as outlined.

Signed 

Printed Name Marla Tahshan

Title President

CONTRACTOR CERTIFICATION

AMERICAN WITH DISABILITIES ACT (ADA) COMPLIANCE CERTIFICATION

PROJECT TITLE: FY'14 Sidewalk Replacement Group 2

I hereby certify that I am familiar with the requirements of San Diego City Council Policy No. 100-4 regarding the American With Disabilities Act (ADA) outlined in the WHITEBOOK, Section 7-13.2, "American With Disabilities Act", of the project specifications, and that;

PAL General Engineering, Inc.
(Name under which business is conducted)

has in place workplace program that complies with said policy. I further certify that each subcontract agreement for this project contains language which indicates the subcontractor's agreement to abide by the provisions of the policy as outlined.

Signed Marla Ah

Printed Name Marla Jahshan

Title President

CONTRACTOR CERTIFICATION

CONTRACTOR STANDARDS – PLEDGE OF COMPLIANCE

PROJECT TITLE: FY'14 Sidewalk Replacement Group 2

I declare under penalty of perjury that I am authorized to make this certification on behalf of PAL General Engineering, Inc., as Contractor, that I am familiar with the requirements of City of San Diego Municipal Code § 22.3224 regarding Contractor Standards as outlined in the WHITEBOOK, Section 7-13.4, ("Contractor Standards"), of the project specifications, and that Contractor has complied with those requirements.

I further certify that each of the Contractor's subcontractors whose subcontracts are greater than \$50,000 in value has completed a Pledge of Compliance attesting under penalty of perjury of having complied with City of San Diego Municipal Code § 22.3224.

Dated this 11th Day of March, 2014.

Signed

Macla Ah

Printed Name

Macla Tahshan

Title

President

AFFIDAVIT OF DISPOSAL

WHEREAS, on the _____ DAY OF _____, 2____, the undersigned entered into and executed a contract with the City of San Diego, a municipal corporation, for:

FY'14 Sidewalk Replacement Group 2

(Name of Project)

as particularly described in said contract and identified as Bid No. **L-14-6115-DBB-2** SAP No. (WBS/IO/CC) **B-14038** and **WHEREAS**, the specification of said contract requires the Contractor to affirm that "all brush, trash, debris, and surplus materials resulting from this project have been disposed of in a legal manner"; and **WHEREAS**, said contract has been completed and all surplus materials disposed of:

NOW, THEREFORE, in consideration of the final payment by the City of San Diego to said Contractor under the terms of said contract, the undersigned Contractor, does hereby affirm that all surplus materials as described in said contract have been disposed of at the following location(s)

and that they have been disposed of according to all applicable laws and regulations.

Dated this _____ DAY OF _____, _____.

Contractor
by

ATTEST:

State of _____
County of _____

On this _____ DAY OF _____, 2____, before the undersigned, a Notary Public in and for said County and State, duly commissioned and sworn, personally appeared _____ known to me to be the _____ Contractor named in the foregoing Release, and whose name is subscribed thereto, and acknowledged to me that said Contractor executed the said Release.

Notary Public in and for said County and State

ATTACHMENTS

ATTACHMENT A
SCOPE OF WORK

SCOPE OF WORK

1. **SCOPE OF WORK:** Repair/replacement of tree damaged sidewalks, installation of curb ramps, remove trees, replace trees as noted, curb & gutter repair/replacement. Driveway repair-Citywide.
 - 1.1. The Work shall be **performed** in accordance with:
 - 1.1.1. This Notice Inviting Bids, inclusive.
2. **CONSTRUCTION COST:** The City's estimated construction cost for this contract is **\$322,000.00.**
3. **LOCATION OF WORK:** See location list attached in Appendix
4. **CONTRACT TIME:** The Contract Time for completion of the Work shall be **100 Working Days.**
5. **CONTRACTOR'S LICENSE CLASSIFICATION:** In accordance with the provisions of California Law, the Contractor shall possess valid appropriate license(s) at the time that the Bid is submitted. Failure to possess the specified license(s) shall render the Bid as **non-responsive** and shall act as a bar to award of the Contract to any Bidder not possessing required license(s) at the time of Bid.

5.1. The City has determined the following licensing classifications for this contract:

Option	Classifications
1	CLASS A
2	CLASS C8

5.2 The Bidder shall satisfy the licensing requirement by meeting **at least** one of the listed options.

ATTACHMENT B
INTENTIONALLY LEFT BLANK

ATTACHMENT C
EQUAL OPPORTUNITY CONTRACTING PROGRAM

EQUAL OPPORTUNITY CONTRACTING PROGRAM

1. To The WHITEBOOK, Chapter 10, Sections D and E, DELETE each in its entirety, and SUBSTITUTE with the following:

D. CITY'S EQUAL OPPORTUNITY COMMITMENT.

1. Nondiscrimination in Contracting Ordinance.

1. The Contractor, Subcontractors and Suppliers shall comply with requirements of the City's Nondiscrimination in Contracting Ordinance, San Diego Municipal Code §§22.3501 through 22.3517.

The Contractor shall not discriminate on the basis of race, gender, religion, national origin, ethnicity, sexual orientation, age, or disability in the solicitation, selection, hiring, or treatment of subcontractors, vendors, or suppliers. The Contractor shall provide equal opportunity for subcontractors to participate in subcontracting opportunities. The Contractor understands and agrees that violation of this clause shall be considered a material breach of the contract and may result in contract termination, debarment, or other sanctions.

The Contractor shall include the foregoing clause in all contracts between the Contractor and Subcontractors and Suppliers.

2. Disclosure of Discrimination Complaints. As part of its Bid or Proposal, the Bidder shall provide to the City a list of all instances within the past 10 years where a complaint was filed or pending against Bidder in a legal or administrative proceeding alleging that Bidder discriminated against its employees, subcontractors, vendors, or suppliers, and a description of the status or resolution of that complaint, including any remedial action taken.
3. Upon the City's request, the Contractor agrees to provide to the City, within 60 days, a truthful and complete list of the names of all Subcontractors and Suppliers that the Contractor has used in the past 5 years on any of its contracts that were undertaken within San Diego County, including the total dollar amount paid by the Contractor for each subcontract or supply contract.
4. The Contractor further agrees to fully cooperate in any investigation conducted by the City pursuant to the City's Nondiscrimination in Contracting Ordinance, Municipal Code §§22.3501 through 22.3517. The Contractor understands and agrees that violation of this clause shall be considered a material breach of the Contract and may result in remedies being ordered against the Contractor up to and including contract termination, debarment and other sanctions for violation of the provisions of the Nondiscrimination in Contracting Ordinance. The Contractor further understands and agrees that the procedures,

remedies and sanctions provided for in the Nondiscrimination in Contracting Ordinance apply only to violations of the Ordinance.

E. EQUAL EMPLOYMENT OPPORTUNITY OUTREACH PROGRAM.

1. The Contractor, Subcontractors and Suppliers shall comply with the City's Equal Employment Opportunity Outreach Program, San Diego Municipal Code §§22.2701 through 22.2707.

The Contractor shall not discriminate against any employee or applicant for employment on any basis prohibited by law. Contractor shall provide equal opportunity in all employment practices. Prime Contractor shall ensure their subcontractors comply with this program. Nothing in this section shall be interpreted to hold a prime contractor liable for any discriminatory practice of its subcontractors.

The Contractor shall include the foregoing clause in all contracts between the Contractor and Subcontractors and Suppliers.

2. If the Contract is competitively solicited, the selected Bidder shall submit a Work Force Report (Form BB05), within 10 Working Days after receipt by the Bidder of Contract forms to the City for approval as specified in the Notice of Intent to Award letter from the City.
3. If a Work Force Report is submitted, and the City determines there are under-representations when compared to County Labor Force Availability data, the selected Bidder shall submit an Equal Employment Opportunity Plan.
4. If the selected Bidder submits an Equal Employment Opportunity Plan, it shall include the following assurances:
 1. The Contractor shall maintain a working environment free of discrimination, harassment, intimidation and coercion at all sites and in all facilities at which the Contractor's employees are assigned to work.
 2. The Contractor reviews its EEO Policy, at least annually, with all on-site supervisors involved in employment decisions.
 3. The Contractor disseminates and reviews its EEO Policy with all employees at least once a year, posts the policy statement and EEO posters on all company bulletin boards and job sites, and documents every dissemination, review and posting with a written record to identify the time, place, employees present, subject matter, and disposition of meetings.
 4. The Contractor reviews, at least annually, all supervisors' adherence to and performance under the EEO Policy and maintains written documentation of these reviews.
 5. The Contractor discusses its EEO Policy Statement with subcontractors with whom it anticipates doing business, includes the

EEO Policy Statement in its subcontracts, and provides such documentation to the City upon request.

6. The Contractor documents and maintains a record of all bid solicitations and outreach efforts to and from subcontractors, contractor associations and other business associations.
7. The Contractor disseminates its EEO Policy externally through various media, including the media of people of color and women, in advertisements to recruit, maintains files documenting these efforts, and provides copies of these advertisements to the City upon request.
8. The Contractor disseminates its EEO Policy to union and community organizations.
9. The Contractor provides immediate written notification to the City when any union referral process has impeded the Contractor's efforts to maintain its EEO Policy.
10. The Contractor maintains a current list of recruitment sources, including those outreaching to people of color and women, and provides written notification of employment opportunities to these recruitment sources with a record of the organizations' responses.
11. The Contractor maintains a current file of names, addresses and phone numbers of each walk-in applicant, including people of color and women, and referrals from unions, recruitment sources, or community organizations with a description of the employment action taken.
12. The Contractor encourages all present employees, including people of color and women employees, to recruit others.
13. The Contractor maintains all employment selection process information with records of all tests and other selection criteria.
14. The Contractor develops and maintains documentation for on-the-job training opportunities, participates in training programs, or both for all of its employees, including people of color and women, and establishes apprenticeship, trainee, and upgrade programs relevant to the Contractor's employment needs.
15. The Contractor conducts, at least annually, an inventory and evaluation of all employees for promotional opportunities and encourages all employees to seek and prepare appropriately for such opportunities.
16. The Contractor ensures the company's working environment and activities are non-segregated except for providing separate or single-user toilets and necessary changing facilities to assure privacy between the sexes.

ATTACHMENT D
INTENTIONALLY LEFT BLANK

ATTACHMENT E
SUPPLEMENTARY SPECIAL PROVISIONS

SUPPLEMENTARY SPECIAL PROVISIONS

The following Supplementary Special Provisions (SSP) modifies the following documents:

- 1) Standard Specifications for Public Works Construction (The GREENBOOK) currently in effect.
 - 2) The City of San Diego Standard Specifications for Public Works Construction (The WHITEBOOK).
-

SECTION 1 – TERMS, DEFINITIONS, ABBREVIATIONS, UNITS OF MEASURE, AND SYMBOLS

1-2 TERMS AND DEFINITIONS.

Normal Working Hours. To the City Supplement, ADD the following:

The Normal Working Hours are 7:30 AM to 3:30 PM.

SECTION 2 - SCOPE AND CONTROL OF WORK

2-3.2 Self Performance. DELETE in its entirety and SUBSTITUTE with the following:

1. You must perform, with your own organization, Contract work amounting to at least 50% of the base bid alone or base bid and any additive or deductive alternate(s) that together when added or deducted form the basis of award.
2. The self performance percentage requirement will be waived for contracts when a “B” License is required or allowed.

SECTION 4 - CONTROL OF MATERIALS

4-1.6 Trade Names or Equals. ADD the following:

You must submit your list of proposed substitutions for “an equal” item (s) **no later than 15 Working Days after the determination of the Apparent Low Bidder** and on a City form when provided by the City.

SECTION 6 - PROSECUTION, PROGRESS AND ACCEPTANCE OF WORK

6-2.1 **Moratoriums.** To the City Supplement, ADD the following:

Do not work in the areas where there is currently a moratorium issued by the City.

SECTION 7 - RESPONSIBILITIES OF THE CONTRACTOR

7-3 **LIABILITY INSURANCE.** DELETE in its entirety and SUBSTITUTE with the following:

The insurance provisions herein must not be construed to limit your indemnity obligations contained in the Contract.

7-3.1 **Policies and Procedures.**

1. You must procure the insurance described below, at its sole cost and expense, to provide coverage against claims for loss including injuries to persons or damage to property, which may arise out of or in connection with the performance of the Work by you, your agents, representatives, officers, employees or Subcontractors.
2. Insurance coverage for property damage resulting from your operations is on a replacement cost valuation. The market value will not be accepted.
3. You must maintain this insurance for the duration of this contract and at all times thereafter when you are correcting, removing, or replacing Work in accordance with this contract. Your liabilities under the Contract, e.g., your indemnity obligations, is not deemed limited to the insurance coverage required by this contract.
4. Payment for insurance is included in the various items of Work as bid by you, and except as specifically agreed to by the City in writing, you are not entitled to any additional payment. Do not begin any work under this contract until you have provided and the City has approved all required insurance.
5. Policies of insurance must provide that the City is entitled to 30 days (10 days for cancellation due to non-payment of premium) prior written notice of cancellation or non-renewal of the policy. Maintenance of specified insurance coverage is a material element of the Contract. Your failure to maintain or renew coverage or to provide evidence of renewal during the term of the Contract may be treated by the City as a material breach of the Contract.

7-3.2 **Types of Insurance.**

7-3.2.1 **Commercial General Liability Insurance.**

1. Commercial General Liability Insurance must be written on the current version of the ISO Occurrence form CG 00 01 07 98 or an equivalent form providing coverage at least as broad.

2. The policy must cover liability arising from premises and operations, XCU (explosions, underground, and collapse), independent contractors, products/completed operations, personal injury and advertising injury, bodily injury, property damage, and liability assumed under an insured's contract (including the tort liability of another assumed in a business contract).
3. There must be no endorsement or modification limiting the scope of coverage for either "insured vs. insured" claims or contractual liability. You must maintain the same or equivalent insurance for at least 10 years following completion of the Work.
4. All costs of defense must be outside the policy limits. Policy coverage must be in liability limits of not less than the following:

<u>General Annual Aggregate Limit</u>	<u>Limits of Liability</u>
Other than Products/Completed Operations	\$2,000,000
Products/Completed Operations Aggregate Limit	\$2,000,000
Personal Injury Limit	\$1,000,000
Each Occurrence	\$1,000,000

7-3.2.2 Commercial Automobile Liability Insurance.

1. You must provide a policy or policies of Commercial Automobile Liability Insurance written on the current version of the ISO form CA 00 01 12 90 or later version or equivalent form providing coverage at least as broad in the amount of \$1,000,000 combined single limit per accident, covering bodily injury and property damage for owned, non-owned, and hired automobiles ("Any Auto").
2. All costs of defense must be outside the limits of the policy.

7-3.3 Rating Requirements. Except for the State Compensation Insurance Fund, all insurance required by this contract as described herein must be carried only by responsible insurance companies with a rating of, or equivalent to, at least "A-, VI" by A.M. Best Company, that are authorized by the California Insurance Commissioner to do business in the State, and that have been approved by the City.

7-3.3.1 Non-Admitted Carriers. The City will accept insurance provided by non-admitted, "surplus lines" carriers only if the carrier is authorized to do business in the State and is included on the List of Approved Surplus Lines Insurers (LASLI list).

All policies of insurance carried by non-admitted carriers must be subject to all of the requirements for policies of insurance provided by admitted carriers described herein.

7-3.4 Evidence of Insurance. Furnish to the City documents e.g., certificates of insurance and endorsements evidencing the insurance required herein, and furnish renewal documentation prior to expiration of this insurance. Each required document must be signed by the insurer or a person authorized by the insurer to bind coverage on its behalf. We reserve the right to require complete, certified copies of all insurance policies required herein.

7-3.5 Policy Endorsements.

7-3.5.1 Commercial General Liability Insurance

7-3.5.1.1 Additional Insured.

- a) You must provide at your expense policy endorsement written on the current version of the ISO Occurrence form CG 20 10 11 85 or an equivalent form providing coverage at least as broad.
- b) To the fullest extent allowed by law e.g., California Insurance Code §11580.04, the policy must be endorsed to include the City and its respective elected officials, officers, employees, agents, and representatives as additional insured.
- c) The additional insured coverage for projects for which the Engineer's Estimate is \$1,000,000 or more must include liability arising out of: (a) Ongoing operations performed by you or on your behalf, (b) your products, (c) your work, e.g., your completed operations performed by you or on your behalf, or (d) premises owned, leased, controlled, or used by you.
- d) The additional insured coverage for projects for which the Engineer's Estimate is less than \$1,000,000 must include liability arising out of: (a) Ongoing operations performed by you or on your behalf, (b) your products, or (c) premises owned, leased, controlled, or used by you.

7-3.5.1.2 Primary and Non-Contributory Coverage. The policy must be endorsed to provide that the coverage with respect to operations, including the completed operations, if appropriate, of the Named Insured is primary to any insurance or self-insurance of the City and its elected officials, officers, employees, agents and representatives. Further, it must provide that any insurance maintained by the City and its elected officials, officers, employees, agents and representatives must be in excess of your insurance and must not contribute to it.

7-3.5.1.3 Project General Aggregate Limit. The policy or policies must be endorsed to provide a Designated Construction Project General Aggregate Limit that will apply only to the Work. Only claims payments which arise from the Work must reduce the Designated Construction Project General Aggregate Limit. The Designated Construction Project General Aggregate Limit must be in addition to the aggregate limit provided for the products-completed operations hazard.

7-3.5.2 Commercial Automobile Liability Insurance.

7-3.5.2.1 Additional Insured. Unless the policy or policies of Commercial Auto Liability Insurance are written on an ISO form CA 00 01 12 90 or a later version of this form or equivalent form providing coverage at least as broad, the policy must be endorsed to include the City and its respective elected officials, officers, employees, agents, and representatives as additional insured, with respect to liability arising out of automobiles owned, leased, hired or borrowed by you or on your behalf. This endorsement is limited to the obligations permitted by California Insurance Code §11580.04.

7-3.6 Deductibles and Self-Insured Retentions. You must pay for all deductibles and self-insured retentions. You must disclose deductibles and self-insured retentions to the City at the time the evidence of insurance is provided.

7-3.7 Reservation of Rights. The City reserves the right, from time to time, to review your insurance coverage, limits, deductibles and self-insured retentions to determine if they are acceptable to the City. The City will reimburse you, without overhead, profit, or any other markup, for the cost of additional premium for any coverage requested by the Engineer but not required by this contract.

7-3.8 Notice of Changes to Insurance. You must notify the City 30 days prior to any material change to the policies of insurance provided under this contract.

7-3.9 Excess Insurance. Policies providing excess coverage must follow the form of the primary policy or policies e.g., all endorsements.

7-4 WORKERS' COMPENSATION INSURANCE. DELETE in its entirety and SUBSTITUTE with the following:

7-4.1 Workers' Compensation Insurance and Employers Liability Insurance.

1. In accordance with the provisions of §3700 of the California Labor Code, you must provide at your expense Workers' Compensation Insurance and Employers Liability Insurance to protect you against all claims under applicable state workers compensation laws. The City, its elected officials, and employees will not be responsible for any claims in law or equity occasioned by your failure to comply with the requirements of this section.

2. Limits for this insurance must be not less than the following:

<u>Workers' Compensation</u>	<u>Statutory Employers Liability</u>
Bodily Injury by Accident	\$1,000,000 each accident
Bodily Injury by Disease	\$1,000,000 each employee
Bodily Injury by Disease	\$1,000,000 policy limit

3. By signing and returning the Contract you certify that you are aware of the provisions of §3700 of the Labor Code which require every employer to be insured against liability for worker's compensation or to undertake self-insurance in accordance with the provisions of that code and you must comply with such provisions before commencing the Work as required by §1861 of the California Labor Code.

7-4.1.1 Waiver of Subrogation. The policy or policies must be endorsed to provide that the insurer will waive all rights of subrogation against the City, and its respective elected officials, officers, employees, agents, and representatives for losses paid under the terms of the policy or policies and which arise from work performed by the Named Insured for the City.

7-8.6 Water Pollution Control. ADD the following:

1. Based on a preliminary assessment by the City, the Contract is subject to WPCP.

7-10.5.3 Steel Plate Covers. Table 7-10.5.3(A), REVISE the plate thickness for 5'-3" trench width to read 1 3/4".

7-15 INDEMNIFICATION AND HOLD HARMLESS AGREEMENT. To the City Supplement, fourth paragraph, last sentence, DELETE in its entirety and SUBSTITUTE with the following:

Your duty to indemnify and hold harmless does not include any claims or liability arising from the established active or sole negligence, or willful misconduct of the City, its officers, or employees.

SECTION 8 - FACILITIES FOR AGENCY PERSONNEL

8-2 FIELD OFFICE FACILITIES. To the City Supplement, DELETE in its entirety.

SECTION 9 - MEASUREMENT AND PAYMENT

9-3.2.5 Withholding of Payment. To the City Supplement, item i), DELETE in its entirety and SUBSTITUTE with the following:

- i) Your failure to comply with 7-2.3, "PAYROLL RECORDS" and 2-16, "CONTRACTOR REGISTRATION AND ELECTRONIC REPORTING SYSTEM."

ADD:

9-3.7 Compensation Adjustments for Price Index Fluctuations. This Contract is not subject to the provisions of The WHITEBOOK for Compensation Adjustments for Price Index Fluctuations for the paving asphalt.

SECTION 300 – EARTHWORK

300-1.4 Payment. To the City Supplement, paragraph (2), DELETE in its entirety and SUBSTITUTE with the following:

2. Payment for existing pavement removal and disposal of up to 12" thick, within the excavation e.g., trench limits, shall be included in the Bid item for installation of the mains or the Work item that requires pavement removal.

SECTION 302 – ROADWAY SURFACING

302-3 Preparatory Repair Work. To the City Supplement, DELETE in its entirety and SUBSTITUTE with the following:

302-3 Preparatory Repair Work.

1. Prior to roadway resurfacing or the application of slurry, the Contractor shall complete all necessary preparation and repair work to the road segment e.g., tree trimming, weed spray, weed abatement, crack sealing, asphalt repair, hump removal, miscellaneous asphalt patching, removal of raised pavement markers, removal of pavement markings, etc. and as specified in the Special Provisions.
2. Preparatory work shall include, but not be limited to, tree trimming, weed spray, weed abatement, crack sealing, asphalt repair i.e., mill and pave, hump removal, miscellaneous asphalt patching, removal of raised pavement markers, removal of pavement markings, etc.
3. The Contractor shall repair areas of distressed asphalt concrete pavement by milling or removing damaged areas of pavement to a minimum depth of 2” for Residential streets, and a minimum depth of 3” for all others to expose firm and unyielding pavement. The Contractor shall prepare subgrade as needed and install a minimum of 2” for residential streets, and a minimum of 3” for all others, of compacted asphalt concrete pavement over compacted native material as directed by the Engineer.
4. If, in order to achieve the minimum specified depth, the base material is exposed, the material shall be compacted to 95% relative compaction to a depth 10” below the finished grade (dig out). Compaction tests shall be made to ensure compliance with the specifications. The Engineer will determine when and where the test will occur. The City will pay for the soils testing required by the Engineer, which meets the required compaction. The Contractor shall reimburse the City for the cost of retesting failing compaction tests. If additional base material is required, the Contractor shall use Class 2 Aggregate Base in accordance with 400-2.4, “Class 2 Aggregate Base.”
5. Recycled base material shall conform to Crushed Miscellaneous Base Material in accordance with 200-2.4, “Class 2 Aggregate Base.”
6. Prior to replacing asphalt, the area shall be cleaned by removing all loose and damaged material, moisture, dirt, and other foreign matter and shall be tack coated in accordance with 302-5.4 “Tack Coat.”
7. The Contractor shall install new asphalt within the repair area or for patches in accordance with 302-5, “ASPHALT CONCRETE PAVEMENT.” Asphalt concrete shall be C2-PG 64-10 in compliance with 400-4, “ASPHALT CONCRETE.”
8. No preparatory asphalt work shall be done when the atmospheric temperature is below 50 °F or during unsuitable weather.

9. Following the asphalt placement, the Contractor shall roll the entire area of new asphalt in both directions at least twice. The finished patch shall be level and smooth in compliance with 302-5.6.2 "Density and Smoothness." After placement and compaction of the asphalt patch, the Contractor shall seal all finished edges with a 4" wide continuous band of SS-1H.
10. The minimum dimension for each individual repair shall be 4' x 4' and shall be subject to the following conditions:
 - a) If the base material is exposed to achieve the required minimum removal thickness, the base material shall be prepared conforming to 301-1, "SUBGRADE PREPARATION."
 - b) When additional base material is required, then the contractor shall use Class 2 Aggregate Base in accordance with 400-2.4, "Class 2 Aggregate Base." Recycled base material shall conform to Crushed Miscellaneous Base Material in accordance with 200-2.4, "Crushed Miscellaneous Base."
 - c) The Contractor may use grinding as a method for removal of deteriorated pavement when the areas indicated for removal are large enough (a minimum of the machine drum width) and when approved by the Engineer.
 - d) For both scheduled and unscheduled base repairs, failed areas may be removed by milling or by excavation provided that the edges are cut cleanly with a saw. The areas shall be cleaned and tack coated in accordance with 302-5.4, "Tack Coat" before replacing the asphalt. The areas for scheduled repairs have been marked on the street.

302-3.1 Asphalt Patching.

1. Asphalt patching shall consist of patching potholes, gutter-line erosion, and other low spots in the pavement that are deeper than ½" per 302-5.6.2, "Density and Smoothness." These areas are generally smaller and more isolated than those areas in need of mill and pave.
2. The areas requiring patching have been identified in the Contract Documents, marked on the streets, or as directed by the Engineer. The Contractor shall identify any new areas that may require patching prior to slurry work to ensure the smoothness and quality of the finished product.
3. The Contractor shall identify and repair any areas that may require patching, prior to the placement of slurry seal for smooth finished product.
4. Asphalt overlay shall not be applied over deteriorated pavement. Preparatory asphalt work shall be completed and approved by the Engineer before proceeding with asphalt overlay.
5. The Contractor shall remove distressed asphalt pavement either by saw cutting or milling, to expose firm and unyielding pavement; prepare subgrade (as

needed); and install compacted asphalt concrete pavement over compacted native material as directed by the Engineer.

6. Prior to replacing asphalt, the area shall be cleaned and tack coated per 302-5.4, "Tack Coat".
7. Following the asphalt placement, the Contractor shall roll the entire patch in both directions covering the patch at least twice.
8. After placement and compaction of the asphalt patch, the Contractor shall seal all finished edges with a 4" wide continuous band of SS-1H.
9. Base repairs shall not exceed 20% RAP in content.

302-3.2 Payment.

1. Payment for replacement of existing pavement when required shall be included in the unit bid price for Asphalt Pavement repair for the total area replaced and no additional payment shall be made regardless of the number of replacements completed. No payment shall be made for areas of over excavation or outside trench areas in utility works unless previously approved by the Engineer. No payment for pavement replacement will be made when the damage is due to the Contractor's failure to protect existing improvements. The Contractor shall reimburse the City for the cost of retesting all failing compaction tests.
2. The areas and quantities shown on the road segments and in appendices are given only for the Contractor's aid in planning the Work and preparing Bids. The Engineer will designate the limits to be removed and these designated areas shall be considered to take precedent over the area shown in an Appendix to the Contract Documents. The quantities shown in the appendices are based on a street assessment survey and may vary.
3. At the end of each day, the Contractor shall submit to the Engineer an itemized list of the asphalt pavement repair work completed. The list shall include the location of the work and the exact square footage of the repair.
4. Preparatory repair work and tack coating will be paid at the Contract unit price per ton for Asphalt Pavement Repair. No payment shall be made for areas of over excavation unless previously approved by the Engineer.
5. Milling shall be included in the Bid item for Asphalt Pavement Repair unless separate Bid item has been provided.
6. Payment for miscellaneous asphalt patching shall be included in the Contract unit price for slurry and no additional payment shall be made therefore.

302-5.1.1 Damaged AC Pavement Replacement. To the City Supplement, DELETE in its entirety.

302-5.1.2 Measurement and Payment. To the City Supplement, DELETE in its entirety.

302-5.2.1 Measurement and Payment. To the City Supplement, item c), ADD the following:
Imported Subgrade material shall be paid per bid item “Imported Backfill”.

SECTION 308 – LANDSCAPE AND IRRIGATION INSTALLATION

308-7 GUARANTEE. To the City Supplement, DELETE in its entirety.

308-7 Payment. ADD the following:

Work related to tree maintenance shall be included in the Bid items as follows:

- Tree Trimming (EA)
- Root Pruning (EA)
- Root Barrier (EA)

308-8 PAYMENT. To the City Supplement, DELETE in its entirety.

SECTION 705 – WATER DISCHARGES

705-2.6.1 General. Paragraph (3), CORRECT reference to Section 803 to read “Section 703.”

705-2.6.3 Community Health and Safety Plan. To the City Supplement, DELETE in its entirety and SUBSTITUTE with the following:

705-2.6.3 Community Health and Safety Plan. See 703-2, “Community Health and Safety Plan.”

END OF SUPPLEMENTARY SPECIAL PROVISIONS (SSP)

SUPPLEMENTARY SPECIAL PROVISIONS

APPENDICES

APPENDIX A
FIRE HYDRANT METER PROGRAM

CITY OF SAN DIEGO CALIFORNIA DEPARTMENT INSTRUCTIONS	NUMBER DI 55.27	DEPARTMENT Water Department
SUBJECT FIRE HYDRANT METER PROGRAM (FORMERLY: CONSTRUCTION METER PROGRAM)	PAGE 1 OF 10	EFFECTIVE DATE October 15, 2002
	SUPERSEDES DI 55.27	DATED April 21, 2000

1. **PURPOSE**

- 1.1 To establish a Departmental policy and procedure for issuance, proper usage and charges for fire hydrant meters.

2. **AUTHORITY**

- 2.1 All authorities and references shall be current versions and revisions.
- 2.2 San Diego Municipal Code (NC) Chapter VI, Article 7, Sections 67.14 and 67.15
- 2.3 Code of Federal Regulations, Safe Drinking Water Act of 1986
- 2.4 California Code of Regulations, Titles 17 and 22
- 2.5 California State Penal Code, Section 498B.0
- 2.6 State of California Water Code, Section 110, 500-6, and 520-23
- 2.7 Water Department Director

Reference

- 2.8 State of California Guidance Manual for Cross Connection Programs
- 2.9 American Water Works Association Manual M-14, Recommended Practice for Backflow Prevention
- 2.10 American Water Works Association Standards for Water Meters
- 2.11 U.S.C. Foundation for Cross Connection Control and Hydraulic Research Manual

3. **DEFINITIONS**

- 3.1 **Fire Hydrant Meter:** A portable water meter which is connected to a fire hydrant for the purpose of temporary use. (These meters are sometimes referred to as Construction Meters.)

CITY OF SAN DIEGO CALIFORNIA DEPARTMENT INSTRUCTIONS	NUMBER DI 55.27	DEPARTMENT Water Department
SUBJECT FIRE HYDRANT METER PROGRAM (FORMERLY: CONSTRUCTION METER PROGRAM)	PAGE 2 OF 10	EFFECTIVE DATE October 15, 2002
	SUPERSEDES DI 55.27	DATED April 21, 2000

- 3.2 **Temporary Water Use:** Water provided to the customer for no longer than twelve (12) months.
- 3.3 **Backflow Preventor:** A Reduced Pressure Principal Assembly connected to the outlet side of a Fire Hydrant Meter.

4. **POLICY**

- 4.1 The Water Department shall collect a deposit from every customer requiring a fire hydrant meter and appurtenances prior to providing the meter and appurtenances (see Section 7.1 regarding the Fees and Deposit Schedule). The deposit is refundable upon the termination of use and return of equipment and appurtenances in good working condition.
- 4.2 Fire hydrant meters will have a 2 ½" swivel connection between the meter and fire hydrant. The meter shall not be connected to the 4" port on the hydrant. All Fire Hydrant Meters issued shall have a Reduced Pressure Principle Assembly (RP) as part of the installation. Spanner wrenches are the only tool allowed to turn on water at the fire hydrant.
- 4.3 The use of private hydrant meters on City hydrants is prohibited, with exceptions as noted below. All private fire hydrant meters are to be phased out of the City of San Diego. All customers who wish to continue to use their own fire hydrant meters must adhere to the following conditions:
 - a. Meters shall meet all City specifications and American Water Works Association (AWWA) standards.
 - b. Customers currently using private fire hydrant meters in the City of San Diego water system will be allowed to continue using the meter under the following conditions:
 - 1. The customer must submit a current certificate of accuracy and calibration results for private meters and private backflows annually to the City of San Diego, Water Department, Meter Shop.

CITY OF SAN DIEGO CALIFORNIA DEPARTMENT INSTRUCTIONS	NUMBER DI 55.27	DEPARTMENT Water Department
SUBJECT FIRE HYDRANT METER PROGRAM (FORMERLY: CONSTRUCTION METER PROGRAM)	PAGE 3 OF 10	EFFECTIVE DATE October 15, 2002
	SUPERSEDES DI 55.27	DATED April 21, 2000

2. The meter must be properly identifiable with a clearly labeled serial number on the body of the fire hydrant meter. The serial number shall be plainly stamped on the register lid and the main casing. Serial numbers shall be visible from the top of the meter casing and the numbers shall be stamped on the top of the inlet casing flange.
3. All meters shall be locked to the fire hydrant by the Water Department, Meter Section (see Section 4.7).
4. All meters shall be read by the Water Department, Meter Section (see Section 4.7).
5. All meters shall be relocated by the Water Department, Meter Section (see Section 4.7).
6. These meters shall be tested on the anniversary of the original test date and proof of testing will be submitted to the Water Department, Meter Shop, on a yearly basis. If not tested, the meter will not be allowed for use in the City of San Diego.
7. All private fire hydrant meters shall have backflow devices attached when installed.
8. The customer must maintain and repair their own private meters and private backflows.
9. The customer must provide current test and calibration results to the Water Department, Meter Shop after any repairs.
10. When private meters are damaged beyond repair, these private meters will be replaced by City owned fire hydrant meters.

CITY OF SAN DIEGO CALIFORNIA DEPARTMENT INSTRUCTIONS	NUMBER DI 55.27	DEPARTMENT Water Department
SUBJECT FIRE HYDRANT METER PROGRAM (FORMERLY: CONSTRUCTION METER PROGRAM)	PAGE 4 OF 10	EFFECTIVE DATE October 15, 2002
	SUPERSEDES DI 55.27	DATED April 21, 2000

11. When a private meter malfunctions, the customer will be notified and the meter will be removed by the City and returned to the customer for repairs. Testing and calibration results shall be given to the City prior to any re-installation.
 12. The register shall be hermetically sealed straight reading and shall be readable from the inlet side. Registration shall be in hundred cubic feet.
 13. The outlet shall have a 2 ½ “National Standards Tested (NST) fire hydrant male coupling.
 14. Private fire hydrant meters shall not be transferable from one contracting company to another (i.e. if a company goes out of business or is bought out by another company).
- 4.4 All fire hydrant meters and appurtenances shall be installed, relocated and removed by the City of San Diego, Water Department. All City owned fire hydrant meters and appurtenances shall be maintained by the City of San Diego, Water Department, Meter Services.
- 4.5 If any fire hydrant meter is used in violation of this Department Instruction, the violation will be reported to the Code Compliance Section for investigation and appropriate action. Any customer using a fire hydrant meter in violation of the requirements set forth above is subject to fines or penalties pursuant to the Municipal Code, Section 67.15 and Section 67.37.

4.6 Conditions and Processes for Issuance of a Fire Hydrant Meter

Process for Issuance

- a. Fire hydrant meters shall only be used for the following purposes:
 1. Temporary irrigation purposes not to exceed one year.

CITY OF SAN DIEGO CALIFORNIA DEPARTMENT INSTRUCTIONS	NUMBER DI 55.27	DEPARTMENT Water Department
SUBJECT FIRE HYDRANT METER PROGRAM (FORMERLY: CONSTRUCTION METER PROGRAM)	PAGE 5 OF 10	EFFECTIVE DATE October 15, 2002
	SUPERSEDES DI 55.27	DATED April 21, 2000

2. Construction and maintenance related activities (see Tab 2).
 - b. No customer inside or outside the boundaries of the City of San Diego Water Department shall resell any portion of the water delivered through a fire hydrant by the City of San Diego Water Department.
 - c. The City of San Diego allows for the issuance of a temporary fire hydrant meter for a period not to exceed 12 months (365 days). An extension can only be granted in writing from the Water Department Director for up to 90 additional days. A written request for an extension by the consumer must be submitted at least 30 days prior to the 12 month period ending. No extension shall be granted to any customer with a delinquent account with the Water Department. No further extensions shall be granted.
 - d. Any customer requesting the issuance of a fire hydrant meter shall file an application with the Meter Section. The customer must complete a "Fire Hydrant Meter Application" (Tab 1) which includes the name of the company, the party responsible for payment, Social Security number and/or California ID, requested location of the meter (a detailed map signifying an exact location), local contact person, local phone number, a contractor's license (or a business license), description of specific water use, duration of use at the site and full name and address of the person responsible for payment.
 - e. At the time of the application the customer will pay their fees according to the schedule set forth in the Rate Book of Fees and Charges, located in the City Clerk's Office. All fees must be paid by check, money order or cashiers check, made payable to the City Treasurer. Cash will not be accepted.
 - f. No fire hydrant meters shall be furnished or relocated for any customer with a delinquent account with the Water Department.
 - g. After the fees have been paid and an account has been created, the

CITY OF SAN DIEGO CALIFORNIA DEPARTMENT INSTRUCTIONS	NUMBER DI 55.27	DEPARTMENT Water Department
SUBJECT FIRE HYDRANT METER PROGRAM (FORMERLY: CONSTRUCTION METER PROGRAM)	PAGE 6 OF 10	EFFECTIVE DATE October 15, 2002
	SUPERSEDES DI 55.27	DATED April 21, 2000

meter shall be installed within 48 hours (by the second business day). For an additional fee, at overtime rates, meters can be installed within 24 hours (within one business day).

4.7 Relocation of Existing Fire Hydrant Meters

- a. The customer shall call the Fire Hydrant Meter Hotline (herein referred to as “Hotline”), a minimum of 24 hours in advance, to request the relocation of a meter. A fee will be charged to the existing account, which must be current before a work order is generated for the meter’s relocation.
- b. The customer will supply in writing the address where the meter is to be relocated (map page, cross street, etc). The customer must update the original Fire Hydrant Meter Application with any changes as it applies to the new location.
- c. Fire hydrant meters shall be read on a monthly basis. While fire hydrant meters and backflow devices are in service, commodity, base fee and damage charges, if applicable, will be billed to the customer on a monthly basis. If the account becomes delinquent, the meter will be removed.

4.8 Disconnection of Fire Hydrant Meter

- a. After ten (10) months a “Notice of Discontinuation of Service” (Tab 3) will be issued to the site and the address of record to notify the customer of the date of discontinuance of service. An extension can only be granted in writing from the Water Department Director for up to 90 additional days (as stated in Section 4.6C) and a copy of the extension shall be forwarded to the Meter Shop Supervisor. If an extension has not been approved, the meter will be removed after twelve (12) months of use.
- b. Upon completion of the project the customer will notify the Meter Services office via the Hotline to request the removal of the fire hydrant meter and appurtenances. A work order will be generated

CITY OF SAN DIEGO CALIFORNIA DEPARTMENT INSTRUCTIONS	NUMBER DI 55.27	DEPARTMENT Water Department
SUBJECT FIRE HYDRANT METER PROGRAM (FORMERLY: CONSTRUCTION METER PROGRAM)	PAGE 7 OF 10	EFFECTIVE DATE October 15, 2002
	SUPERSEDES DI 55.27	DATED April 21, 2000

for removal of the meter.

- c. Meter Section staff will remove the meter and backflow prevention assembly and return it to the Meter Shop. Once returned to the Meter Shop the meter and backflow will be tested for accuracy and functionality.
- d. Meter Section Staff will contact and notify Customer Services of the final read and any charges resulting from damages to the meter and backflow or its appurtenance. These charges will be added on the customer's final bill and will be sent to the address of record. Any customer who has an outstanding balance will not receive additional meters.
- e. Outstanding balances due may be deducted from deposits and any balances refunded to the customer. Any outstanding balances will be turned over to the City Treasurer for collection. Outstanding balances may also be transferred to any other existing accounts.

5. **EXCEPTIONS**

- 5.1 Any request for exceptions to this policy shall be presented, in writing, to the Customer Support Deputy Director, or his/her designee for consideration.

6. **MOBILE METER**

- 6.1 Mobile meters will be allowed on a case by case basis. All mobile meters will be protected by an approved backflow assembly and the minimum requirement will be a Reduced Pressure Principal Assembly. The two types of Mobile Meters are vehicle mounted and floating meters. Each style of meters has separate guidelines that shall be followed for the customer to retain service and are described below:

- a) **Vehicle Mounted Meters:** Customer applies for and receives a City owned Fire Hydrant Meter from the Meter Shop. The customer mounts the meter on the vehicle and brings it to the Meter Shop for

CITY OF SAN DIEGO CALIFORNIA DEPARTMENT INSTRUCTIONS	NUMBER DI 55.27	DEPARTMENT Water Department
SUBJECT FIRE HYDRANT METER PROGRAM (FORMERLY: CONSTRUCTION METER PROGRAM)	PAGE 8 OF 10	EFFECTIVE DATE October 15, 2002
	SUPERSEDES DI 55.27	DATED April 21, 2000

inspection. After installation is approved by the Meter Shop the vehicle and meter shall be brought to the Meter Shop on a monthly basis for meter reading and on a quarterly basis for testing of the backflow assembly. Meters mounted at the owner's expense shall have the one year contract expiration waived and shall have meter or backflow changed if either fails.

b) **Floating Meters:** Floating Meters are meters that are not mounted to a vehicle. **(Note: All floating meters shall have an approved backflow assembly attached.)** The customer shall submit an application and a letter explaining the need for a floating meter to the Meter Shop. The Fire Hydrant Meter Administrator, after a thorough review of the needs of the customer, (i.e. number of jobsites per day, City contract work, lack of mounting area on work vehicle, etc.), may issue a floating meter. At the time of issue, it will be necessary for the customer to complete and sign the "Floating Fire Hydrant Meter Agreement" which states the following:

- 1) The meter will be brought to the Meter Shop at 2797 Caminito Chollas, San Diego on the third week of each month for the monthly read by Meter Shop personnel.
- 2) Every other month the meter will be read and the backflow will be tested. This date will be determined by the start date of the agreement.

If any of the conditions stated above are not met the Meter Shop has the right to cancel the contract for floating meter use and close the account associated with the meter. The Meter Shop will also exercise the right to refuse the issuance of another floating meter to the company in question.

Any Fire Hydrant Meter using reclaimed water shall not be allowed use again with any potable water supply. The customer shall incur the cost of replacing the meter and backflow device in this instance.

CITY OF SAN DIEGO CALIFORNIA DEPARTMENT INSTRUCTIONS	NUMBER DI 55.27	DEPARTMENT Water Department
SUBJECT FIRE HYDRANT METER PROGRAM (FORMERLY: CONSTRUCTION METER PROGRAM)	PAGE 9 OF 10	EFFECTIVE DATE October 15, 2002
	SUPERSEDES DI 55.27	DATED April 21, 2000

7. **FEE AND DEPOSIT SCHEDULES**

7.1 **Fees and Deposit Schedules:** The fees and deposits, as listed in the Rate Book of Fees and Charges, on file with the Office of the City Clerk, are based on actual reimbursement of costs of services performed, equipment and materials. These deposits and fees will be amended, as needed, based on actual costs. Deposits, will be refunded at the end of the use of the fire hydrant meter, upon return of equipment in good working condition and all outstanding balances on account are paid. Deposits can also be used to cover outstanding balances.

All fees for equipment, installation, testing, relocation and other costs related to this program are subject to change without prior notification. The Mayor and Council will be notified of any future changes.

8. **UNAUTHORIZED USE OF WATER FROM A HYDRANT**

8.1 Use of water from any fire hydrant without a properly issued and installed fire hydrant meter is theft of City property. Customers who use water for unauthorized purposes or without a City of San Diego issued meter will be prosecuted.

8.2 If any unauthorized connection, disconnection or relocation of a fire hydrant meter, or other connection device is made by anyone other than authorized Water Department personnel, the person making the connection will be prosecuted for a violation of San Diego Municipal Code, Section 67.15. In the case of a second offense, the customer's fire hydrant meter shall be confiscated and/or the deposit will be forfeited.

8.3 Unauthorized water use shall be billed to the responsible party. Water use charges shall be based on meter readings, or estimates when meter readings are not available.

8.4 In case of unauthorized water use, the customer shall be billed for all applicable charges as if proper authorization for the water use had been obtained, including but not limited to bi-monthly service charges, installation charges and removal charges.

CITY OF SAN DIEGO CALIFORNIA DEPARTMENT INSTRUCTIONS	NUMBER DI 55.27	DEPARTMENT Water Department
SUBJECT FIRE HYDRANT METER PROGRAM (FORMERLY: CONSTRUCTION METER PROGRAM)	PAGE 10 OF 10	EFFECTIVE DATE October 15, 2002
	SUPERSEDES DI 55.27	DATED April 21, 2000

- 8.5 If damage occurs to Water Department property (i.e. fire hydrant meter, backflow, various appurtenances), the cost of repairs or replacements will be charged to the customer of record (applicant).

**Larry Gardner
Water Department Director**

- Tabs: 1. Fire Hydrant Meter Application
2. Construction & Maintenance Related Activities With No Return To Sewer
3. Notice of Discontinuation of Service

APPENDIX

Administering Division: Customer Support Division

Subject Index: Construction Meters
Fire Hydrant
Fire Hydrant Meter Program
Meters, Floating or Vehicle Mounted
Mobile Meter
Program, Fire Hydrant Meter

Distribution: DI Manual Holders



Application for Fire Hydrant Meter (EXHIBIT A)

(For Office Use Only)

NS REQ	FAC#
DATE	BY

METER SHOP (619) 527-7449

Meter Information

Application Date	Requested Install Date:
------------------	-------------------------

Fire Hydrant Location: (Attach Detailed Map//Thomas Bros. Map Location or Construction drawing.) <u>Zip:</u>	T.B.	G.B. (CITY USE)
Specific Use of Water:		
Any Return to Sewer or Storm Drain, if so, explain:		
Estimated Duration of Meter Use: <input type="text"/>	<input type="checkbox"/>	Check Box if Reclaimed Water

Company Information

Company Name:			
Mailing Address:			
City:	State:	Zip:	Phone: ()
*Business license#		*Contractor license#	
A Copy of the Contractor's license OR Business License is required at the time of meter issuance.			
Name and Title of Billing Agent: <small>(PERSON IN ACCOUNTS PAYABLE)</small>			Phone: ()
Site Contact Name and Title:			Phone: ()
Responsible Party Name:			Title:
Cal ID#			Phone: ()
Signature:		Date:	
<small>Guarantees Payment of all Charges Resulting from the use of this Meter. Insures that employees of this Organization understand the proper use of Fire Hydrant Meter</small>			

Fire Hydrant Meter Removal Request	Requested Removal Date:
Provide Current Meter Location if Different from Above:	
Signature:	Title: Date:
Phone: ()	Pager: ()

<input type="checkbox"/> City Meter	<input type="checkbox"/> Private Meter	
Contract Acct #:	Deposit Amount: \$ 936.00	Fees Amount: \$ 62.00
Meter Serial #	Meter Size: 05	Meter Make and Style: 6-7
Backflow #	Backflow Size:	Backflow Make and Style:
Name:	Signature:	Date:

WATER USES WITHOUT ANTICIPATED CHARGES FOR RETURN TO SEWER

Auto Detailing
Backfilling
Combination Cleaners (Vactors)
Compaction
Concrete Cutters
Construction Trailers
Cross Connection Testing
Dust Control
Flushing Water Mains
Hydro Blasting
Hydro Seeing
Irrigation (for establishing irrigation only; not continuing irrigation)
Mixing Concrete
Mobile Car Washing
Special Events
Street Sweeping
Water Tanks
Water Trucks
Window Washing

Note:

1. If there is any return to sewer or storm drain, then sewer and/or storm drain fees will be charges.

Date

Name of Responsible Party
Company Name and Address
Account Number: _____

Subject: Discontinuation of Fire Hydrant Meter Service

Dear Water Department Customer:

The authorization for use of Fire Hydrant Meter # _____, located at *(Meter Location Address)* ends in 60 days and will be removed on or after *(Date Authorization Expires)*. Extension requests for an additional 90 days must be submitted in writing for consideration 30 days prior to the discontinuation date. If you require an extension, please contact the Water Department, or mail your request for an extension to:

City of San Diego
Water Department
Attention: Meter Services
2797 Caminito Chollas
San Diego, CA 92105-5097

Should you have any questions regarding this matter, please call the Fire Hydrant Hotline at (619) _____ - _____.

Sincerely,

Water Department

APPENDIX B

MATERIALS TYPICALLY ACCEPTED BY CERTIFICATE OF COMPLIANCE

Materials Typically Accepted by Certificate of Compliance

1. Soil amendment
2. Fiber mulch
3. PVC or PE pipe up to 16 inch diameter
4. Stabilizing emulsion
5. Lime
6. Preformed elastomeric joint seal
7. Plain and fabric reinforced elastomeric bearing pads
8. Steel reinforced elastomeric bearing pads
9. Waterstops (Special Condition)
10. Epoxy coated bar reinforcement
11. Plain and reinforcing steel
12. Structural steel
13. Structural timber and lumber
14. Treated timber and lumber
15. Lumber and timber
16. Aluminum pipe and aluminum pipe arch
17. Corrugated steel pipe and corrugated steel pipe arch
18. Structural metal plate pipe arches and pipe arches
19. Perforated steel pipe
20. Aluminum underdrain pipe
21. Aluminum or steel entrance tapers, pipe downdrains, reducers, coupling bands and slip joints
22. Metal target plates
23. Paint (traffic striping)
24. Conductors
25. Painting of electrical equipment
26. Electrical components
27. Engineering fabric
28. Portland Cement
29. PCC admixtures
30. Minor concrete, asphalt
31. Asphalt (oil)
32. Liquid asphalt emulsion
33. Epoxy

APPENDIX C
SAMPLE CITY INVOICE

City of San Diego, Field Engineering Div., 9485 Aero Drive, SD CA 92123						Contractor's Name:					
Project Name:						Contractor's Address:					
SAP No. (WBS/IO/CC):											
City Purchase Order No. :						Contractor's Phone #:			Invoice No.		
Resident Engineer (RE):						Contractor's Fax #:			Invoice Date:		
RE Phone#:			RE Fax#:			Contact Name:			Billing Period:		
Item #	Item Description	Contract Authorization				Previous Estimate		This Estimate		Totals to Date	
		Unit	Qty	Price	Extension	%/QTY	Amount	% / QTY	Amount	% / QTY	Amount
1	2 Parallel 4" PVC C900	LF	1,380	\$34.00	\$46,920.00						
2	48" Primary Steel Casing	LF	500	\$1,000.00	\$500,000.00						
3	2 Parallel 12" Secondary Steel	LF	1,120	\$53.00	\$59,360.00						
4	Construction and Rehab of PS 49	LS	1	\$150,000.00	\$150,000.00						
5	Demo	LS	1	\$14,000.00	\$14,000.00						
6	Install 6' High Chain Link Fence	LS	1	\$5,600.00	\$5,600.00						
7	General Site Restoration	LS	1	\$3,700.00	\$3,700.00						
8	10" Gravity Sewer	LF	10	\$292.00	\$2,920.00						
9	4" Blow Off Valves	EA	2	\$9,800.00	\$19,600.00						
10	Bonds	LS	1	\$16,000.00	\$16,000.00						
11	Field Orders	AL	1	80,000	\$80,000.00						
11.1	Field Order 1	LS	5,500	\$1.00	\$5,500.00						
11.2	Field Order 2	LS	7,500	\$1.00	\$7,500.00						
11.3	Field Order 3	LS	10,000	\$1.00	\$10,000.00						
11.4	Field Order 4	LS	6,500	\$1.00	\$6,500.00						
12	Certified Payroll	LS	1	\$1,400.00	\$1,400.00						
CHANGE ORDERS											
Change Order 1			4,890								
Items 1-4					\$11,250.00						
Item 5-Deduct Bid Item 3		LF	120	-\$53.00	(\$6,360.00)						
Change Order 2			160,480								
Items 1-3					\$95,000.00						
Item 4 Deduct Bid Item 1		LF	380	-\$340.00	(\$12,920.00)						
Item 5-Encrease bid Item 9		LF	8	\$9,800.00	\$78,400.00						
Change Order 3 (Close Out)			-121,500								
Item 1 Deduct Bid Item 3			53	-500.00	(\$26,500.00)						
Item 2 Deduct Bid Item 4		LS	-1	45,000.00	(\$45,000.00)						
Items 3-9			1	-50,500.00	(\$50,500.00)						
SUMMARY								Total This	\$ -	Total Billed	\$0.00
A. Original Contract Amount						Retention and/or Escrow Payment Schedule					
B. Approved Change Order 1 Thru 3						Total Retention Required as of this billing					
C. Total Authorized Amount (A+B)						Previous Retention Withheld in PO or in Escrow					
D. Total Billed to Date						Add'l Amt to Withhold in PO/Transfer in Escrow:					
E. Less Total Retention (5% of D)						Amt to Release to Contractor from PO/Escrow:					
F. Less Total Previous Payments											
G. Payment Due Less Retention						Contractor Signature and Date:					
H. Remaining Authorized Amount											

APPENDIX D
TREE RELATED DRAWINGS

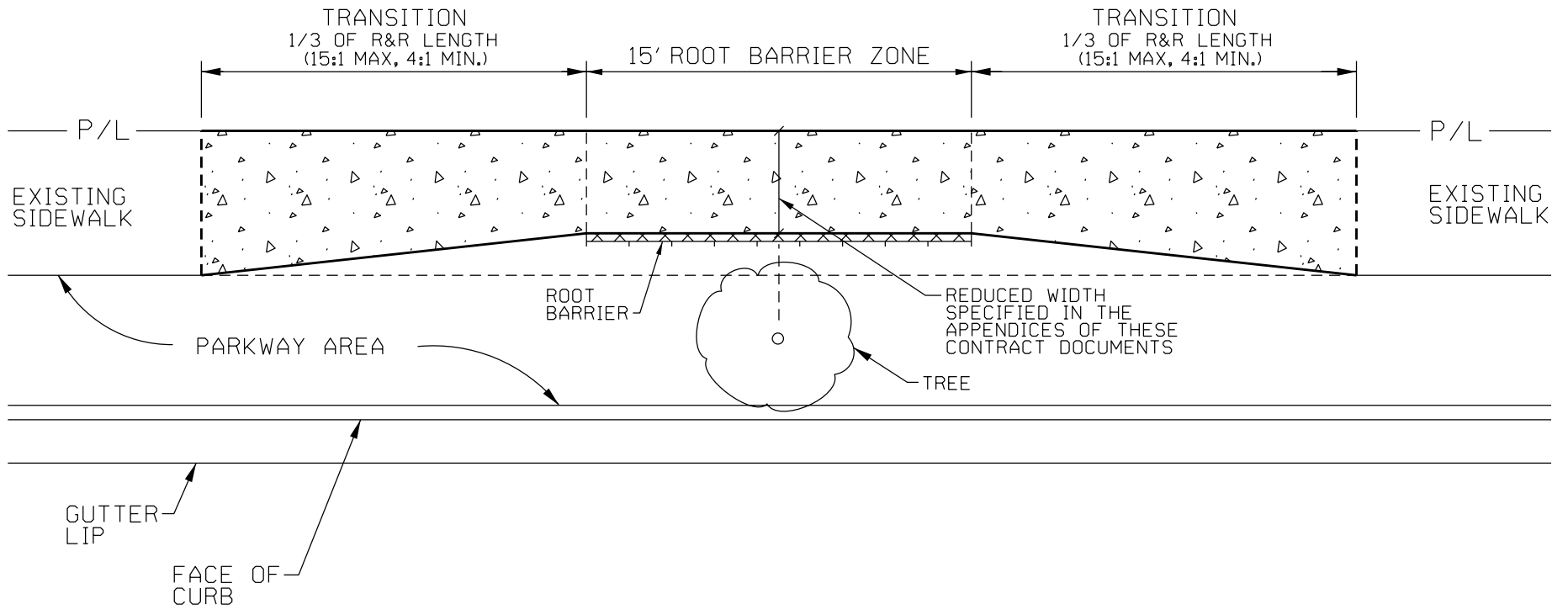

**SIDEWALK WIDTH REDUCTION
AROUND A FIXED OBJECT**

CITY OF SAN DIEGO, CALIFORNIA
GENERAL SERVICES DEPARTMENT

DESCRIPTION	BY	APPROVED	DATE	D-1
ORIGINAL	GEFROM		6-2-09	

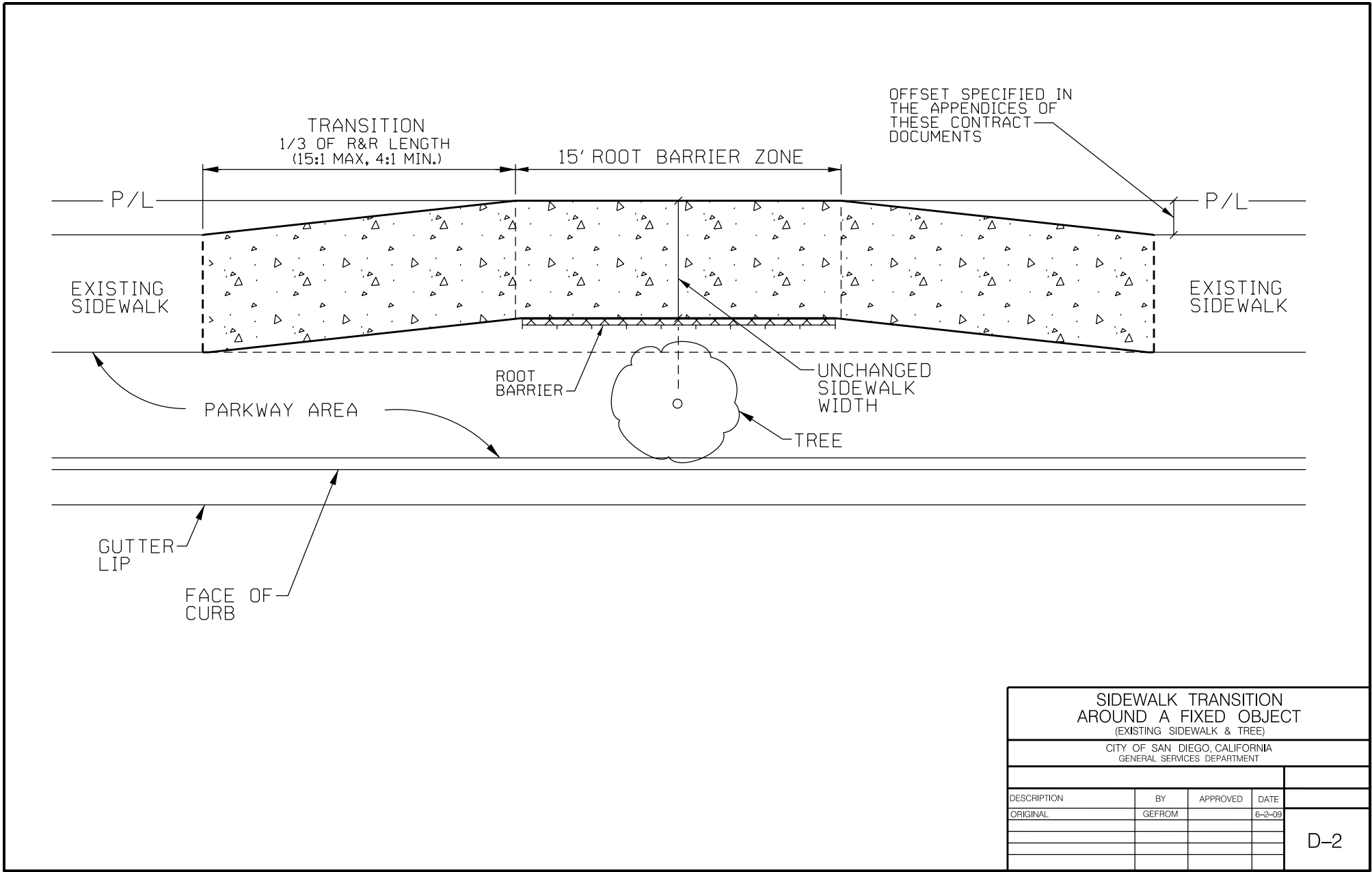

SIDEWALK TRANSITION AROUND A FIXED OBJECT (EXISTING SIDEWALK & TREE)			
CITY OF SAN DIEGO, CALIFORNIA GENERAL SERVICES DEPARTMENT			
DESCRIPTION	BY	APPROVED	DATE
ORIGINAL	GEFROM		6-2-09

D-2

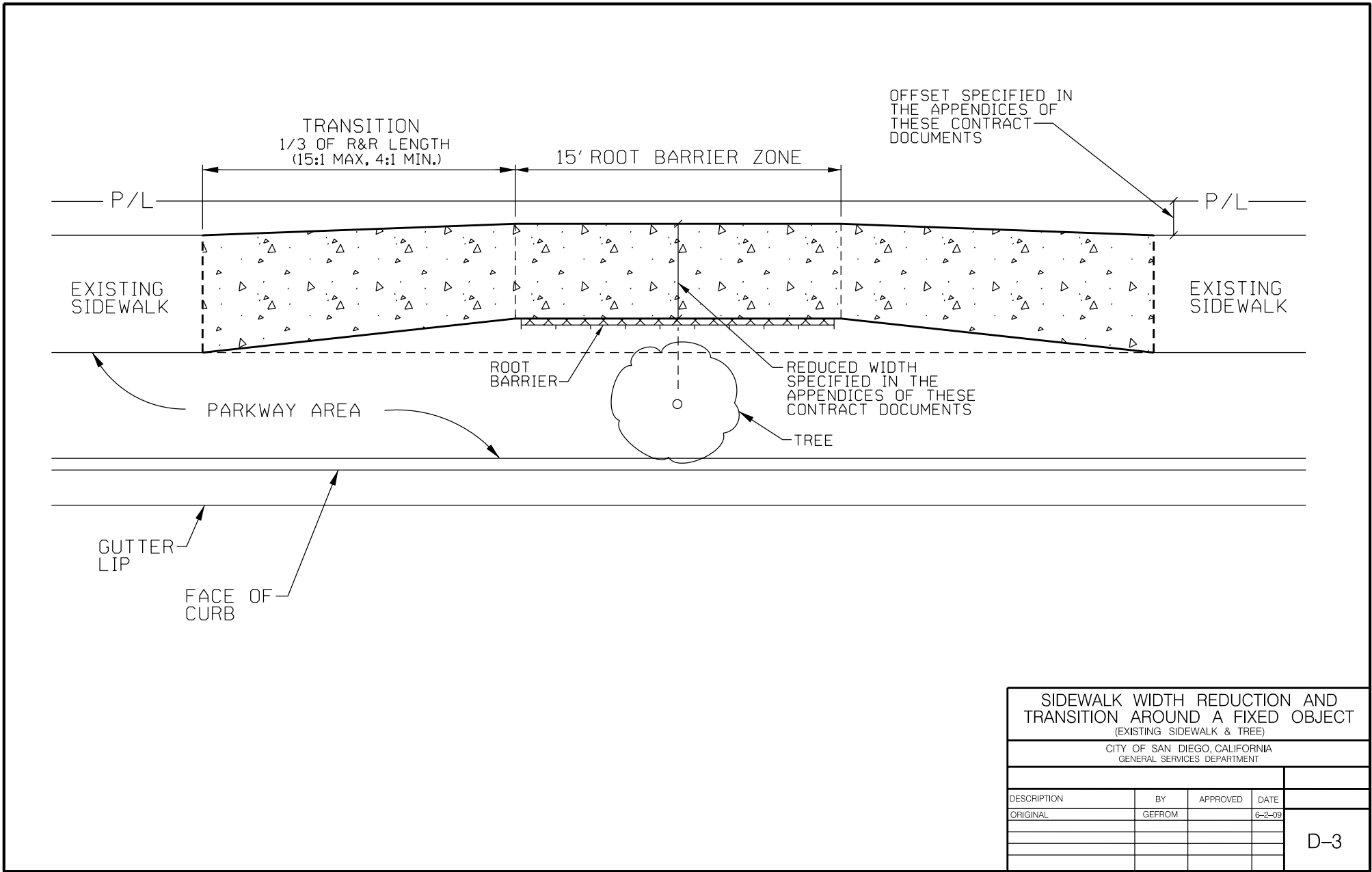

SIDEWALK WIDTH REDUCTION AND TRANSITION AROUND A FIXED OBJECT (EXISTING SIDEWALK & TREE)			
CITY OF SAN DIEGO, CALIFORNIA GENERAL SERVICES DEPARTMENT			
DESCRIPTION	BY	APPROVED	DATE
ORIGINAL	GEFROM		6-2-09

D-3

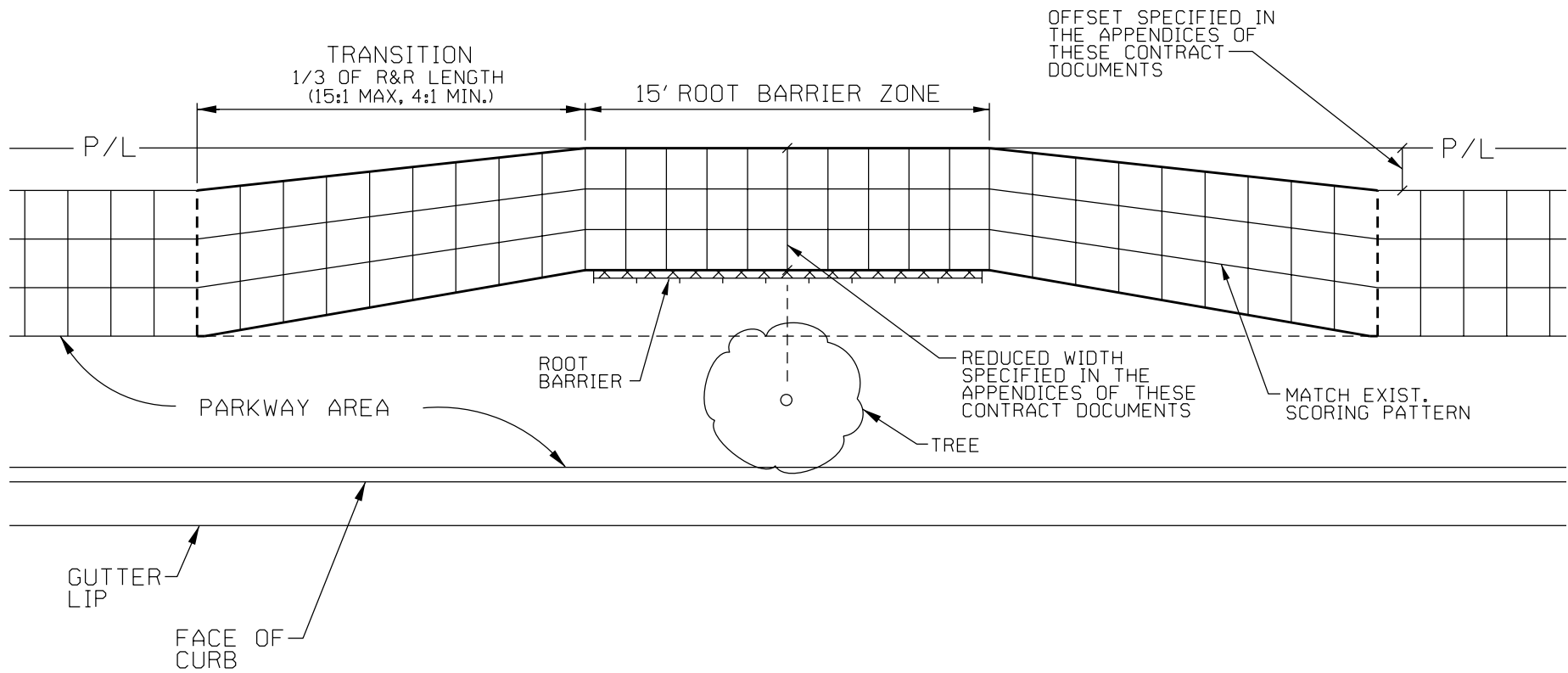

SIDEWALK SCORING PATTERN

CITY OF SAN DIEGO, CALIFORNIA
GENERAL SERVICES DEPARTMENT

DESCRIPTION	BY	APPROVED	DATE
ORIGINAL	GEFROM		6-2-09

D-4

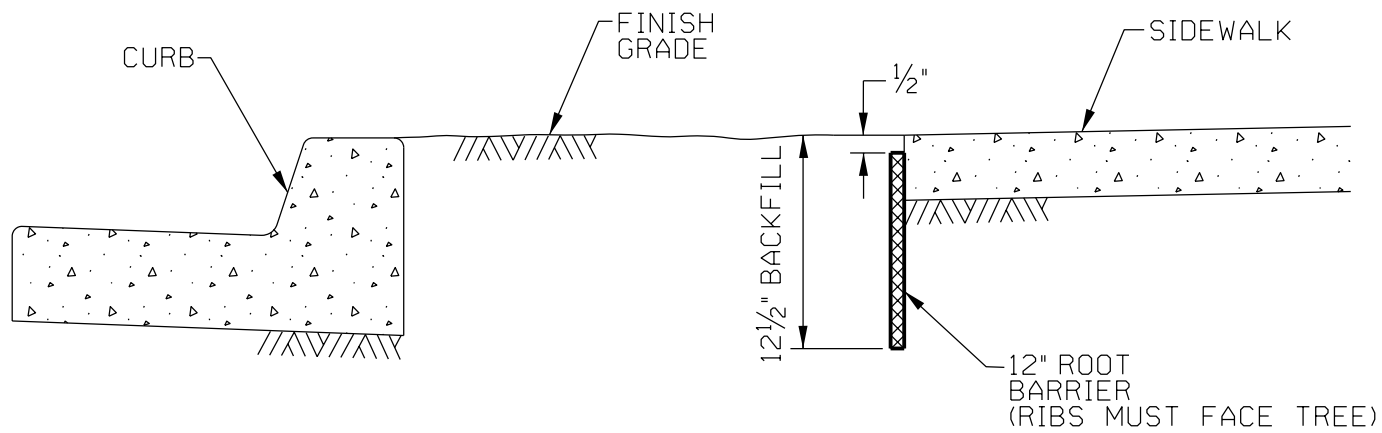

ROOT BARRIER AT SIDEWALK			
CITY OF SAN DIEGO, CALIFORNIA GENERAL SERVICES DEPARTMENT			
DESCRIPTION	BY	APPROVED	DATE
ORIGINAL	GEFROM		6-2-09

D-5

APPENDIX E
PROJECT LOCATION LIST

SN#	Map No.	LOCATION	Est Shv in'	Est SW sq'	Est DW sq'	Est CG lin'	Crb Rmp ea	RB lin'	# Trees	TREE RECOMMENDATION	CONCRETE WORK	Surveyed By
150000505164	1149-H7	11109 INDIAN LORE CT(121'Eo addr;		185				15	1	RP (WINTER ONLY); 3Pine 16" 24" 24"	R&R SW 4x25 & 4x15, ShvSW(2loc)3in-ft	GM
150000505156	1149-H7	11109 INDIAN LORE CT(Acr from add;		60				15	1	RPAD; Liq 10"	SWredu to 3.5'@tree(4) R&R SW 4x15 across from 11109 Indian Lore Ct	GM
150000505909	1150-B6	18397 CAMBERWELL LN on ESCALA DR;		195				15	1	RP (WINTER ONLY); 2Pine 16"	R&R SW 4x17, x31 On Escala & across street from this address on Escala	GM
150000537565	1150-C7	12609 CAMINO EMPARRADO; SWALK RAMPED		260				15	1		R&R SW 4x65	GM
150000535564	1169-H2	11293 CAPILLA RD; SIDEWALK RAMPED		240				15	1		R&R SW 4x60 on Olmeda Way	GM
150000509009	1169-H5	15263 - 93 MATURIN DR; SWALK		290				15	1	RP (WINTER) Pine 30"	R&R SW 5x30, x12,x16, WW3x6	GM
150000489082	1169-H7	11085 AVNDA MARIA; SW		120				15	1	NO RP; At this time /1	R&R SW 4x30	GM
150000539966	1169-J2	16935 WEST BERNARDO DR; SIDEWALK RAMPED		240				15	1		R&R SW 4x60	GM
150000519879	1169-J2	W BERNARDO DR - Es300So Rcho Bdo Rd;		100				15	1	RP Pine (Winter Only) 18"	R&R SW4x25, D25 drainoutlet	GM
150000539433	1169-J4	11311 CLOUDCREST DR; SIDEWALK RAMPED		64				15	1		R&R SW 4x16 Sw Shv (2) Loc	GM
150000539428	1169-J4	A/F 11266 TRAILSIDE CT; SIDEWALK RAMPED		1560			2	60	2	Attain City PM clearance prior to RP	R&R SW 4x300, 4x90 across from address, 2CrbRmpC2	GM
150000539431	1169-J4	A/F 11488 TURTLEBACK LN.; SWALK RAMPED		100				15	1		R&R SW 4x25	GM
150000507120	1169-J5	15717-41 LOFTY TL DR (Acr/from);		340		43		45	3	RP;3 Euc 20",20",10"	R&R SW 4x85 CG43'	GM
150000539442	1169-J5	16029 BLAZEWOOD WY; SIDEWALK RAMPED		60				15	1		R&R SW 4x15	GM
150000540375	1170-A1	17530-17549 BERNARDO CENTER DR; SW RMPD		120				15	1		R&R SW 4x30	GM

SN#	Map No.	LOCATION	Est Shv in'	Est SW sq'	Est DW sq'	Est CG lin'	Crb Rmp ea	RB lin'	# Trees	TREE RECOMMENDATION	CONCRETE WORK	Surveyed By
150000535939	1170-A2	17110 BERNARDO CENTER DR; SW RAMPED		204				15	1		R&R SW 5x52	GM
150000538042	1170-C1	12477 FLORESTA CT; SIDEWALK RAMPED		80				15	1		R&R SW 5x15	GM
150000538864	1170-C2	12502 PACATO SOUTH CR; SIDEWALK RAMPED		64				15	1		R&R SW 4x16	GM
150000538455	1170-C2	A/F12698 PACATO CIR. SO; SIDEWALK RAMPED		64				15	1		R&R 4x12 across from address	GM
150000538465	1170-C2	A/F12720 GIBRALTAR DR; SIDEWALK RAMPED		60				15	1		R&R SW 4x15	GM
150000539414	1170-C3	CRESTA DR & SONORA RD; SIDEWALK RAMPED		80				15	1		R&R SW 4x20	GM
150000538026	1170-D1	17529-17539 PLAZA OTONAL; SWALK RAMPED		60				15	1		R&R SW 4x15	GM
150000537986	1170-D1	17636 CUMANA TR; SIDEWALK RAMPED		40				15	1	Priv Tree	R&R SW 4x10	GM
150000538432	1170-D2	17716 MONTERO RD; SIDEWALK RAMPED		20				15	1		R&R SW 4x5	GM
150000515074	1187-H6	13617 CALAIS DR; SWtree		80				15	1	RP Street tree 14"	R&R SW 4x20	GM
150000515072	1187-H6	SEC DEL MAR HEIGHTS & MERCADO; SWtree		20				15	1	No RP; palm not a factor	R&R SW 4x5	GM
150000510169	1188-D4	5173 SEAGROVE PL; SWtree		40				15	1	S	R&R SW 4x10	GM
150000483437	1188-D5	4946 SMITH CANYON CT on xST; SWtree		200				15	1	RP Liq 12"	R&R SW 5x40. 2SM	GM
150000483433	1188-D5	4999 BEAUCHAMP on Ashley Falls;		70				15	1	RP Syc 10"	R&R SW 5x5, & 3x15 at storm drain	GM
150000516247	1189-E4	9701 CRML MTN on PASEO MONTALBAN; SWtree		180				60	4	RP 4Ficus 24"-30"	R&R SW 4x20, x10 NWC on Paseo Montalban, x15 on CM Rd	GM
150000475264	1189-E5	9624 LIMAR WY; SWtree		40				15	1	RP Podo 26"	R&R SW 4x10	GM

SN#	Map No.	LOCATION	Est Shv in'	Est SW sq'	Est DW sq'	Est CG lin'	Crb Rmp ea	RB lin'	# Trees	TREE RECOMMENDATION	CONCRETE WORK	Surveyed By
150000488375	1189-F4	CARMEL MT -Ss200Eo PASEO CARDIEL;SW		225				15	1	RP Euc 36"	R&R SW 5x20,x25 by bus stop	GM
150000488372	1189-G4	10250 CARMEL MOUNTAIN RD; SWtree		75				15	1	RP proside tree 23"	R&R SW 5x15, ShvSW(3loc)12in-ft	GM
150000508380	1189-G5	10185 PASEO MONTRIL; SWtree		60				15	1	Rmv Euc 24"; plnt Rhus	R&R SW 4x15 cul-de-sac by fire hydrant	GM
150000488431	1189-H2	10820 CARMEL MTN RD; SWtree		60			1	15	1	RP Ash 22"	R&R SW 4X15; R&R CrbRmpC1	GM
150000488432	1189-H2	10830 CARMEL MT RD; SW		80				15	1	RP Ash 23"	R&R SW 4x45	GM
150000488433	1189-H2	10834 CARMEL MTN RD; SWtree		120				15	1	RP Ash 34"	R&R SW 4X30	GM
150000488434	1189-H2	10838 CARMEL MTN RD; SWtree		240				30	2	RP 2Ash 37", 15"	R&R SW 4X60	GM
150000488427	1189-H2	CARMEL MTN & CMTA DELUZ -NEC; SWtree		186				15	1	RP Ash 36"	R&R SW 4X45, 1x6	GM
150000520139	1189-H4	13497 COOL LAKE WY; SWtree		260				45	3	RPAD 3 Carotwd 14" 14" 15"	SWred to 3.5'@trees(4)x45, x20 on Evening Creek Dr. on side of 13497	GM
150000515960	1190-B1	14114, 16 VIA ALISAL; SWtree		136				15	2	RPB; 2 Xylosma 14" 13"	R&R SW 4x34	GM
150000515290	1190-B3	13705 LINDAMERE LN; SIDEWALK		60				15	1	RP; Jac 9"	R&R SW 4x15	GM
150000459327	1208-A3	11100 VISTA SORRENTO PY;SWtree		340				15	1	Rmv Poplar 16"	R&R SW 5x40, x35	GM
150000459164	1208-B3	4000-4099 VIA MAR DE DELFINAS;		325			1	15	2	Rmv 2Poplar 16"	R&R SW 5x51, x14, Rmp	GM
150000583520	1208-C3	E OCEAN AIR DR -Es 250' So Carmel Mtn Rd		240				15	2	Rmv; 2 Syc 11" 6" plnt 2 Lager	R&R 4x30, x30, 200ft south of Torrey Corde	GM
150000506572	1208-C7	10655,65,75 SORRENTO VALLEY RD; SW tree		50				15	1	RP Pkytree 13"	R&R SW 5x10	GM
150000485707	1208-D1	5075 STERLING GROVE LN; SW TREE		40	45			15	1	RP Chi Flm 13"	R&R SW 4x10, DW 8.5x5	GM

SN#	Map No.	LOCATION	Est Shv in'	Est SW sq'	Est DW sq'	Est CG lin'	Crb Rmp ea	RB lin'	# Trees	TREE RECOMMENDATION	CONCRETE WORK	Surveyed By
150000480552	1208-E2	5427 FOXHOUND WY on TROTTER DR;SW		75				45	4	RPAD 4 Broadleaf 14"-15"	SWred to 4'@trees 5x15	GM
500000073861	1209-A5	7851 FLANDERS DR on Parkdale Av; SW		305			1	45	2	RPAD 2 Euc 15" 16"	SWred3.5'@trees (4)x23, x47, 3x5, CrmpC2	GM
150000574733	1209-E6	9680 KEARNY VILLA RD; SWtree		100				15	1	RPAD Euc 16"	SWred to 4'@tree 5x10, x10	GM
150000566042	1209-F5	9900 OLD GROVE RD; SIDEWALK RAMPED		125				15	1	Plant Rhus	R&R 5x10, x15	GM
150000510462	1209-G5	10075 CARROLL CANYON RD; SWtree		150	30	36		15	1	RP Euc 20"	R&R SW 5x30, DW 5x6, CG36	GM
150000523632	1210-C4	RUE CHANTEMAR -E/s @ROUGEMONT PL;		180				15	2	RP 2 Liq 10" 12"	R&R SW 4X35, 4X10	GM
150000523601	1210-C5	10085 RUE CHANTEMAR - 150' E/o adr;		180				15	1	RPAD Liq 13"	R&R SW 4X35, 4X10	GM
150000524417	1210-C5	10170 RUE CHANTEMAR; SIDEWALK RAMPED		160				15	1		R&R SW 4x40	GM
150000523630	1210-C5	10205-10235 RUE TOURAINE; SWALK RAMPED		290				15	1		R&R SW 4X22,X35, X5, X10	GM
150000523745	1210-C5	RUE CHANTEMAR - Es75No RUE VINCENNES;		210				15	2	RP 2 Liqam 13" 14"	R&R SW 4x52	GM
150000514668	1227-E7	530 MARINE ST; SWtree		175				15	1	Rmv Liq 11"; Plnt Lager	R&R SW 5x35	GM
150000521810	1227-E7	639 PEARL ST; SWtree		50				15	1	No RP at this time	R&R SW 5x10	GM
150000496121	1227-E7	7420 DRAPER AV; SW-TREES		50				15	1	No RP; trees will be replcd by U/P	R&R SW 5x10	GM
150000517826	1227-F6	1303 CAVE ST; SIDEWALK RAMPED		250				15	1	RP Cpepr 48"	R&R SW 5.5x45 hst	GM
150000514354	1227-F6	8040 GIRARD AV; SIDEWALK RAMPED		50				15	1	RP city tree 6" multi	R&R SW 5x10 on Coast Blvd	GM
150000557037	1227-F7	1127 VIRGINIA WY; SWtree		275				30	3	RPAD 3 mela 28"	R&R 5x30, x25	GM

SN#	Map No.	LOCATION	Est Shv in'	Est SW sq'	Est DW sq'	Est CG lin'	Crb Rmp ea	RB lin'	# Trees	TREE RECOMMENDATION	CONCRETE WORK	Surveyed By
150000514051	1227-F7	7556 FAY AV; SWtree		75				15	1	RP Ash 16"	R&R SW 5x15	GM
150000501809	1227-H5	2370 AVNDA DE LA PLAYA; SWALK RAMPED		180				15	1	Plnt Rhus	R&R SW 4x35, DW 4x10	GM
150000476618	1227-H5	8228 LA JOLLA SHORES DR; SWtree		170				15	1	RP Magn 24"	R&R SW 5x22, x12	GM
150000478418	1227-J7	7793 SENN WY -xVIA CAPRI; SW-tree		80				15	1	RP; WINTER ONLY Pine 16"	R&R SW 4x20	GM
150000496929	1228-B4	VIA SONOMA & Via Marin SEC; TREE SW		75			1	15	1	RP (WINTER); Pines 36"	R&R SW 5x15, RmpC2	GM
500000073075	1228-B6	2565 ANGELL AV; SIDEWALK		120				15	1	Rmv Euc 39"; Plnt Agonis	R&R SW 4x30	GM
150000487230	1228-C6	5573 SANDBURG AV; SWtree		100				15	1	Plnt BauVP	R&R SW 4x25	GM
150000487655	1228-C6	5633 SANDBURG AV; SWtree		60				15	1	RP Jac 14"	R&R SW 4X15	GM
150000511196	1228-D2	9514 TOWNE CENTER on EASTGATE; SW		75				15	1	RP Liq 15"	R&R SW 5x15	GM
150000473411	1228-D4	GENESEE AV E/S 185' SO GEN COVE; SW		192				15	1	RP; Mela 30"	R&RSW 4x48	GM
150000524825	1228-E1	5608 EASTGATE DR; SIDEWALK RAMPED		140				15	1		R&R SW 5x28	GM
500000055376	1228-E4	GENESEE AV & CALGARY DR -SEC; SW		80				15	1	Rmv stump; Plnt Rhus lancea	R&R SW 4x20	GM
150000508411	1228-E5	6010 AGEE ST on ZENAKO ST; SWtree		200	80			15	1	RP Carrotwood 12"	R&R SW 4x30, DW 4x20, R&R SW 4X20 across street	GM
150000493351	1228-E5	6223 RADCLIFFE DR (a/f); SW TREE		120				15	2	RP 2 Euc 36"	R&R SW 4x30	GM
150000494781	1228-E5	6239 RADCLIFFE DR (a/f); SW TREE		180				15	1	RP Euc 34"	R&R SW 4x45	GM
150000493346	1228-E5	6247 RADCLIFFE DR (a/f); SW TREE		140		45		30	3	RP 3 Eucs 36" 29" 33"	R&R SW 4x45, x20, x15, CG45	GM

SN#	Map No.	LOCATION	Est Shv in'	Est SW sq'	Est DW sq'	Est CG lin'	Crb Rmp ea	RB lin'	# Trees	TREE RECOMMENDATION	CONCRETE WORK	Surveyed By
150000508423	1228-E5	6455 LIPMANN ST; SWtree		280				15	1	RP pkytree 14"	R&R SW 4x30,x20,x20	GM
150000508396	1228-E6	5954 COZZENS ST; AC RAMPED SE		80				15	1	RPAD pkytree	R&R SW 4x20	GM
150000490360	1228-E7	4143 COLE WY; SWtree		100				15	1	No Rp at this time Bris 17"	R&R SW 4x25	GM
500000082615	1228-F4	4721 RAMSAY AV*; SIDEWALK RAMPED		120				15	1	Rmv Liq 14; Plnt Oxy	R&R SW 4x30	GM
150000503336	1228-F5	4595-4605 ROBBINS ST; SWtree		320	80			15	1	Plnt Rhus	R&R SW 4x80, DW 4x20	GM
150000504539	1228-G7	4845 BARSTOW ST; SWtree		180		30		15	1	Rmv Ash 15"; Plnt Rhus	R&R SW 4x45, CG30	GM
150000495859	1228-G7	5021 CADET ST; Shv SW		144				15	1	RPB; Priv tree	R&R SW 4x36	GM
150000473221	1228-H7	5130 ARVINELS AV; SWtree		80				15	1	RP Bris 14"	R&R SW 4x20	GM
150000485435	1228-H7	5184 CONRAD AV; SWtree		120				15	1	Rmv Pkytree; Plnt Rhus	R&R SW 4x30	GM
150000506974	1247-E1	336 NAUTILUS ST; SWtree		64				15	1	Plant Rhus	R&R SW 4x16	GM
150000494288	1247-F1	731 ARENAS ST; TREE FELL		60	84	21		15	2	Plnt 2 Spathodia 15gal	R&R SW 4X15,R&R DW 7x12, CG 21'	GM
150000506990	1247-F2	654 GRAVILLA ST; SWtree		104				15	1	RPAD Bris 12"	R&R SW 4x20, x6	GM
150000486031	1247-F3	5710 DOLPHIN PL; SWtree		40				15	1	RPAD Pkytree 36"	SWred to 3.5'@tree 4x10	GM
150000500817	1247-F3	5771 LA JOLLA HERMOSA AV; SW		150				15	1	RP; Ficus 25"	R&R SW 5x30	GM
150000499778	1247-G2	1364 LA JOLLA RANCHO RD; SW R/UF11		180	400			30	6	Rmv 6 Liq; Plnt 2 Rhus	R&R SW 4x45, DW 12x16, x17	GM
150000475338	1247-G4	430 COLIMA ST; SWtree		250				15	1	Plant Rhus	R&R SW 5X50	GM
150000506972	1247-G4	622 COLIMA ST & A/F 603; SWtree		400			2	15	2	RPAD 2 Euc 36" 18" 2Palms 24"	SWred 4'@trees 5x25, x55, 2CrbmpD	GM
150000499019	1247-G4	720 COLIMA ST; SWtree UF11		875			2	30	2	RP 2 Liq 16" 14"	R&R SW 5x80, x70, x25, 2CrbRmpD	GM
150000517931	1247-H5	1069-1073 LORING ST; SWtree		150				15	1	RP Carob 48"	R&R SW 5x30 outside church	GM
150000483191	1247-H5	5010 CASS ST; SWtree		125				15	1	No RP; Pkytree not a factor	R&R SW 5x25	GM
150000515230	1247-H5	929 OPAL ST; SWtree		160				15	1	RP Street tree 14"	R&R SW 4x40	GM

SN#	Map No.	LOCATION	Est Shv in'	Est SW sq'	Est DW sq'	Est CG lin'	Crb Rmp ea	RB lin'	# Trees	TREE RECOMMENDATION	CONCRETE WORK	Surveyed By
150000500679	1247-H6	945-55 DIAMOND ST; ShvSW tree		75				15	1	RP; Brisbox 10"	R&R SW 5x15	GM
150000506993	1247-H7	864 REED AV acr from address; SWtree		200				15	1	RPAD Carob 40"	R&R SW 5x40	GM
150000512017	1247-J5	1243 BERYL ST; SWtree		225				15	2	Rmv 2 Liq; plnt 2 Oxy	R&R SW 5x45 HstFin	GM
150000492850	1247-J5	1359 BERYL ST; SW TREE		175				15	1	RP Podo 22"	R&R SW 5x35	GM
150000511640	1247-J5	1420 - 1428 BERYL ST; SWtree		200				15	1	RP Ash 16"	R&R SW 5x40	GM
150000503966	1247-J5	1531 MISSOURI ST; SW TREE		50				15	1	RP; Cedar 36"	R&R SW 5x10 HstFin	GM
150000500973	1247-J6	1045 REED AV (A/f addr) SW tree		100				15	1	RP; Carob 36"	R&R SW 5x10,x10	GM
150000482119	1247-J6	1133 OLIVER AV; SWtree		200	180			15	1	RP (winter) Pine 24"	SWred4'@tree 5x40, DW20x9	GM
150000505995	1247-J6	1151 OLIVER AV; SWtree		100				15	1	RP Jac 18"	R&R SW 5x20	GM
150000513038	1247-J6	1234 HORNBLEND ST; SWtree		380				15	1	RPAD RFgum 20"	SWred to 4'@tree; R&R SW 4x95	GM
150000482686	1247-J6	1404 THOMAS AV; SWtree		160	160	24		15	1	Rmv Mela 24"; Plnt Rhus on xSt side	R&R SW 4x40, DW12x13, CG24	GM
150000572859	1247-J6	1414 THOMAS AV; TreeSW		200				15	2	RPAD 2 Coast Live Oak 23" 21"	SWtran/red 12"/4' @trees (5)x40	GM
150000514667	1247-J6	1450 HORNBLEND ST; SWtree		125				15	1	RP RF Gum 19"	R&R SW 5x25 HstFin	GM
150000516853	1247-J6	1492 THOMAS AV; SWtree		150				15	1	RPAD Pkytree 29"	SWred to 4'@tree (5)x30	GM
150000505994	1247-J7	1011 OLIVER AV; SWtree		150				15	1	RP Pine 22"	R&R SW 5x30	GM
150000505466	1248-A2	5685 SOLEDAD MTN RD; SWtree		40				15	2	RP 2 Podo 13" 13"	R&R SW 4x10	GM
150000535082	1248-A4	1888 BERYL ST; SWprivTree		300				15	1	RP Propside tree 42"	R&R SW 5x60, across street from address	GM
150000482120	1248-A5	1611 CHALCEDONY ST; SWtree		175				15	1	Plnt Rhus	R&R SW 5x15, x20	GM
150000506183	1248-A5	1979 HORNBLEND ST; SWtree		125	25			15	1	RP Cpepr 38"	R&R SW 5x25, WW 2.5x10	GM
150000481013	1248-A6	1545-51 REED AV; SWtree		400				15	2	RPAD 2Carob20"	R&R SW 5x80	GM

SN#	Map No.	LOCATION	Est Shv in'	Est SW sq'	Est DW sq'	Est CG lin'	Crb Rmp ea	RB lin'	# Trees	TREE RECOMMENDATION	CONCRETE WORK	Surveyed By
150000582536	1248-A6	4236 INGRAHAM ST; SIDEWALK RAMPED		200				15	1	Rmv Pine 20"; Plnt Rhus	R&R 5x40	GM
150000515770	1248-A7	3609 YOSEMITE ST; SWtree		310	80			45	3	No tree removal or replacement, install root barriers	R&R SW 5x62, DW 5x16	GM
150000480492	1248-A7	3609, 15 YOSEMITE ST; SWtree		660				30	4	RPAD 4 Carotwd 15"	SWred to 4.5'@trees (5)x60, x60, also 5x12 across street from address	GM
150000502618	1248-A7	3802 KENDALL ST; SWtree		75				15	1	Mela 21" (ROW=20')	R&R SW 5x15	GM
150000508570	1248-A7	3970 INGRAHAM ST; SWtree UF		120	160	60		15	1	Torrey Pine (landmark tree), call City arborist prior to root pruning, winter only	Driveway repair 10x16, R&R SW 4X30, CG 60, asphalt 12x60	GM
150000482745	1248-B4	SOLEDAD MTN RD Ws135No Crownhill Rd;		75				15	1	No new tree to be planted	R&R SW 5x15	GM
150000586709	1248-B5	2204 GARNET AV; SWtree		200				45	4	Rmv Liq (8) 12" Plnt Oxy Plnt 4 Oxy	R&R 5X40	GM
150000510336	1248-B5	2207 GARNET AV; SWtree		550				15	1	RP Liq 14", Mela 36"	R&R SW 5.5x60, x40	GM
150000473392	1248-B5	2250 GARNET AV; SWtree		750	80			15	1	Rmv Liq 12" Plnt Oxy, remove tree stump	R&R SW 5x40, x30, x80 DW 4x10,x10	GM
150000506396	1248-C1	3151, 41 HAIDAS AV; SWtree		200				15	1	RP Kaffir 13"; Plnt Rhus, remove tree stump	R&R SW 5x40	GM
150000512267	1248-D1	3253-3255 CLAIREMONT MESA Bl; SW RAMPED		440				15	2	RP 2Carotwd 11" 13"	R&R SW 4x30, x30, x50	GM
150000494928	1248-D1	3295 LUNA AV; SWpalms		240				15	3	RPAD 3 Palms 36" 35" 34"	SWtran 12"@palms 4x60	GM
150000552030	1248-D1	3626 POCAHONTAS CT; SIDEWALK RAMPED		120				15	1	RP JAC 8"	R&R SW 4x30	GM
150000610918	1248-D3	3285 WHEAT on RAFFEE DR; SWALK RAMPED		450		20		15	1		R&R SW 5x90, CG 20	GM
150000512028	1248-D3	4167 MORAGA AV; SWtree		240	40			15	1	Rmv Ash 22"; Plnt Rhus	R&R SW 4x60, DW 4x10	GM
150000537635	1248-D4	4077 PADUCAH DR; SIDEWALK RAMPED		100				15	1	Rmv Mela 27"; Plnt Rhus	R&R 4x25	GM

SN#	Map No.	LOCATION	Est Shv in'	Est SW sq'	Est DW sq'	Est CG lin'	Crb Rmp ea	RB lin'	# Trees	TREE RECOMMENDATION	CONCRETE WORK	Surveyed By
150000580393	1248-E1	4309-11 CLAIREMONT MESA BL; SWALK RAMPED		260		60		15	2	Rmv 2 Pepr 18" 15";Plnt 2 Oxy	R&R SW 4x30, x35, CG 30 & 30	GM
150000487679	1248-E2	3934 WILLIAMETTE AV; SWtree		100	210	100		15	2	Rmv 2 Ash 18" 19"; Plnt 2 Rhus	R&R SW 4x25, DW 6x15, DW 8x15, CG100	GM
150000512488	1248-E2	3934,44 WILLAMETTE AV ; SWtree		300	275	45		15	2	Rmv 2Ash 17" 22"; Plnt 2Rhus	R&R SW 4x30, x15 ,x30; DW 8x17, x17, CG30 &15	GM
150000501118	1248-E2	4546 ONONDAGA AV; SIDEWALK RAMPED		120				15	1	RPAD carotwd 16"	SWtran 6"@tree 4x30	GM
150000556767	1248-E7	2252 FRANKFORT ST; SIDEWALK RAMPED		150				15	2	Rmv 2 Cr 9" 10" plnt 2 Lager	R&R 5x30	GM
150000512987	1248-F1	4582 CHATEAU DR; SWtree		240				15	1	Rmv Carotwd 14"; Plnt Rhus	R&R SW 4x30, x30	GM
150000508607	1248-F1	4729 MT LA PLATTA DR; SWtree		120				15	1	RPAD Carotwd 17"	SWtran 6"@tree 4x30	GM
150000437721	1248-F4	3735 COWLEY WY; TreeReplc		104	68	60		15	1	Rmv Carob 30"; plnt Rhus Lancea 15g	R&R SW 4x26,DW 4X17, CG 60	GM
150000483341	1248-G1	4551 MT LA PLATTA PL; SWtree		80				15	1	RP Jac 10"	R&R SW 4x20	GM
150000516635	1248-G1	4674 BOXWOOD DR; SWtree		100				15	1	RP Brisbox 14"	R&R SW 4x25	
150000485423	1248-G1	4863 CHATEAU DR; SWtree		140	24	40		15	1	Plnt Rhus	R&R SW 4x35, DW4x6, Cutout Twell 4.5x8	
150000485425	1248-G2	4975 CHATEAU DR; SWtree		120				15	1	RP Carotwd 22"	R&R SW 4x30	
150000512661	1248-G2	5158 CHATEAU DR; SWtree		500	60			15	2	Rmv 2 Carotwd 14"; Plnt 2 Rhus	R&R SW 4x125, DW 5X12	

APPENDIX F
DOOR HANGER

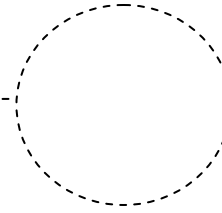
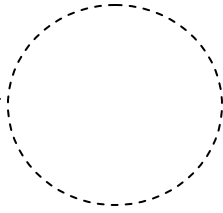

(Contractor Name)

(Contractor Name)

At Your Service!

GOOD NEWS! We plan to begin working on a new sidewalk / curb replacement near your address within the next three working days.

At Your Service!

GOOD NEWS! We plan to begin working on a new sidewalk / curb replacement near your address within the next three working days.

Q. HOW LONG WILL THIS WORK TAKE?

A. It should take about five working days to remove and replace damaged areas of sidewalk, and final clean up (including any irrigation line repairs) will follow in the next week.

Q. HOW LONG WILL THIS WORK TAKE?

A. It should take about five working days to remove and replace damaged areas of sidewalk, and final clean up (including any irrigation line repairs) will follow in the next week.

Q. CAN I WRITE IN THE WET CEMENT?

A. No, but you may walk on your new sidewalk 24 hours after it is poured. It's ok to drive on it in about 21 days.

Q. CAN I WRITE IN THE WET CEMENT?

A. No, but you may walk on your new sidewalk 24 hours after it is poured. It's ok to drive on it in about 21 days.

Q. WILL MY SPRINKLERS GET DAMAGED?

A. If this occurs, we will repair the broken lines. After new sidewalk is placed, please do not install irrigation pipes in the space between tree(s) and sidewalk as this is the root-barrier zone.

Q. WILL MY SPRINKLERS GET DAMAGED?

A. If this occurs, we will repair the broken lines. After new sidewalk is placed, please do not install irrigation pipes in the space between tree(s) and sidewalk as this is the root-barrier zone.

Q. WILL MY STREET IMPROVEMENTS BE DAMAGED?

A. At times, we must remove bricks or other encroachments from the parkway in order to do our work in the public right of way. These items are returned to the fronting property owner.

Q. WILL MY STREET IMPROVEMENTS BE DAMAGED?

A. At times, we must remove bricks or other encroachments from the parkway in order to do our work in the public right of way. These items are returned to the fronting property owner.

Q. WHAT ABOUT PARKING?

A. We appreciate your cooperation in parking out of our work area and apologize for any inconvenience. NO PARKING signs may be placed to allow us room to work.

Q. WHAT ABOUT PARKING?

A. We appreciate your cooperation in parking out of our work area and apologize for any inconvenience. NO PARKING signs may be placed to allow us room to work.

Thank You

We hope you will be pleased with this improvement to your area

Thank You

We hope you will be pleased with this improvement to your area

PHONE NUMBERS

Concrete Contractor (24 Hour): _____
Resident Engineer (Inspector): _____

PHONE NUMBERS

Concrete Contractor (24 Hour): _____
Resident Engineer (Inspector): _____

ATTACHMENT F
INTENTIONALLY LEFT BLANK

✓ valid, CA

City of San Diego

CONTRACTOR'S NAME: PAL General Engineering, Inc.
 ADDRESS: 5374 Eastgate Mall, San Diego, CA 92121
 TELEPHONE NO.: (858) 638-7100 FAX NO.: (858) 638-7102
 CITY CONTACT: Claudia Abarca - Contract Specialist, Email: Cabarca@sandiego.gov
 Phone No. (619) 533-3439, Fax No. (619) 533-3633
 G.Martedi / KA / LS

CONTRACT DOCUMENTS



FOR

FY'14 SIDEWALK REPLACEMENT GROUP 2

VOLUME 2 OF 2

BID NO.: _____ L-14-6115-DBB-2
 SAP NO. (WBS/IO/CC): _____ B-14038
 CLIENT DEPARTMENT: _____ 2116
 COUNCIL DISTRICT: _____ CITYWIDE
 PROJECT TYPE: _____ II / IJ

THIS CONTRACT IS SUBJECT TO THE FOLLOWING:

- THE CITY'S SUBCONTRACTING PARTICIPATION REQUIREMENTS FOR SLBE PROGRAM.
- COMPETITION RESTRICTED TO: SLBE-ELBE or ELBE FIRMS ONLY .
- PREVAILING WAGE RATES: STATE FEDERAL

THIS BIDDING DOCUMENT TO BE SUBMITTED IN ITS ENTIRETY
 REFER TO VOLUME 1 COVER PAGE FOR TIME, DATE, AND LOCATION

TABLE OF CONTENTS

DESCRIPTION

PAGE NUMBER

Volume 2 - Bidding Documents

The following forms must be completed in their entirety and submitted with the Bid. Include the form(s) even if the information does not apply. Where the information does not apply write in N/A. Failure to include any of the forms may cause the Bid to be deemed **non-responsive**. If you are uncertain or have any questions about any required information, contact the City no later than 14 days prior to Bid due date.

1. Bid/Proposal.....	3
2. Bid Bond.....	6
3. Non-Collusion Affidavit to be executed by Bidder and Submitted with Bid under 23 USC 112 and PCC 7106	7
4. Contractors Certification of Pending Actions.....	8
5. Equal Benefits Ordinance Certification of Compliance.....	9
6. Proposal (Bid).....	10
7. Form AA35 - List of Subcontractors	13
8. Form AA40 - Named Equipment/Material Supplier List	14

BIDDING DOCUMENTS

PROPOSAL

Bidder's General Information

To the City of San Diego:

Pursuant to "Notice Inviting Bids", specifications, and requirements on file with the City Clerk, and subject to all provisions of the Charter and Ordinances of the City of San Diego and applicable laws and regulations of the United States and the State of California, the undersigned hereby proposes to furnish to the City of San Diego, complete at the prices stated herein, the items or services hereinafter mentioned. The undersigned further warrants that this bid is not made in the interest of, or on behalf of, any undisclosed person, partnership, company, association, organization, or corporation; that the bid is genuine and not collusive or sham; that the bidder has not directly or indirectly induced or solicited any other bidder to put in a false or sham bid, and has not directly or indirectly colluded, conspired, connived, or agreed with any bidder or anyone else to put in a sham bid, or that anyone shall refrain from bidding; that the bidder has not in any manner, directly or indirectly, sought by agreement, communication, or conference with anyone to fix the bid price of the bidder or any other bidder, or to fix any overhead, profit, or cost element of the bid price, or of that of any other bidder, or to secure any advantage against the public body awarding the contract of anyone interested in the proposed contract; that all statements contained in the bid are true; and, further, that the bidder has not, directly or indirectly, submitted his or her bid price or any breakdown thereof, or the contents thereof, or divulged information or data relative thereto, or paid, and will not pay, any fee to any corporation, partnership, company, association, organization, bid depository, or to any member or agent thereof to effectuate a collusive or sham bid.

The undersigned bidder(s) further warrants that bidder(s) has thoroughly examined and understands the entire Contract Documents (plans and specifications) and the Bidding Documents therefore, and that by submitting said Bidding Documents as its bid proposal, bidder(s) acknowledges and is bound by the entire Contract Documents, including any addenda issued thereto, as such Contract Documents incorporated by reference in the Bidding Documents.

IF A SOLE OWNER OR SOLE CONTRACTOR SIGN HERE:

- (1) Name under which business is conducted _____
- (2) Signature (Given and surname) of proprietor _____
- (3) Place of Business (Street & Number) _____
- (4) City and State _____ Zip Code _____
- (5) Telephone No. _____ Facsimile No. _____
- (6) Email Address _____

IF A PARTNERSHIP, SIGN HERE:

- (1) Name under which business is conducted _____

BIDDING DOCUMENTS

(2) Name of each member of partnership, indicate character of each partner, general or special (limited):

(3) Signature (Note: Signature must be made by a general partner)

Full Name and Character of partner

(4) Place of Business (Street & Number) _____

(5) City and State _____ Zip Code _____

(6) Telephone No. _____ Facsimile No. _____

(7) Email Address _____

IF A CORPORATION, SIGN HERE:

(1) Name under which business is conducted PAL General Engineering, Inc.

(2) Signature, with official title of officer authorized to sign for the corporation:

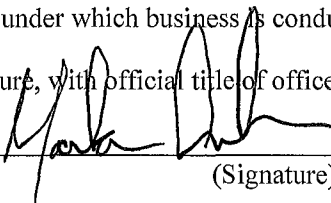

(Signature)

Marla Jahshan

(Printed Name)

President

(Title of Officer)

(Impress Corporate Seal Here)

(3) Incorporated under the laws of the State of California

(4) Place of Business (Street & Number) 5374 Eastgate Mall

(5) City and State San Diego, CA Zip Code 92121

(6) Telephone No. (858) 638-7100 Facsimile No. (858) 638-7102

(7) Email Address info@palsd.com

BIDDING DOCUMENTS

THE FOLLOWING SECTIONS MUST BE FILLED IN BY ALL PROPOSERS:

In accordance with the "NOTICE INVITING BIDS", the bidder holds a California State Contractor's license for the following classification(s) to perform the work described in these specifications:

LICENSE CLASSIFICATION A

LICENSE NO. 916931 EXPIRES 4/30/2015

This license classification must also be shown on the front of the bid envelope. Failure to show license classification on the bid envelope may cause return of the bid unopened.

TAX IDENTIFICATION NUMBER (TIN): [REDACTED]

Email Address: info@palsd.com

THIS PROPOSAL MUST BE NOTARIZED BELOW:

I certify, under penalty of perjury, that the representations made herein regarding my State Contractor's license number, classification and expiration date are true and correct.

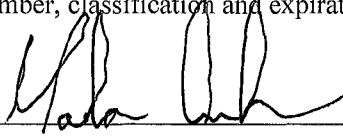
Signature  Title President

SUBSCRIBED AND SWORN TO BEFORE ME, THIS _____ DAY OF _____.

Notary Public in and for the County of _____, State of _____

(NOTARIAL SEAL)

See attached Jurat

State of California
County of San Diego

Subscribed and sworn to (or affirmed) before me on this 26th
day of February, 2014, by Marla Jahshan

_____ ,
proved to me on the basis of satisfactory evidence to be the
person~~(s)~~ who appeared before me.



Signature _____

BIDDING DOCUMENTS

BID BOND

KNOW ALL MEN BY THESE PRESENTS,

That PAL General Engineering, Inc. as Principal, and
The Hanover Insurance Company as Surety, are held and firmly bound unto The City of San Diego hereinafter called "OWNER," in the sum of **10% OF THE TOTAL BID AMOUNT** for the payment of which sum, well and truly to be made, we bind ourselves, our heirs, executors, administrators, successors, and assigns, jointly and severally, firmly by these presents.

WHEREAS, said Principal has submitted a Bid to said OWNER to perform the WORK required under the bidding schedule(s) of the OWNER's Contract Documents entitled

FY' 14 Sidewalk Replacement Group 2

NOW THEREFORE, if said Principal is awarded a contract by said OWNER and, within the time and in the manner required in the "Notice Inviting Bids" enters into a written Agreement on the form of agreement bound with said Contract Documents, furnishes the required certificates of insurance, and furnishes the required Performance Bond and Payment Bond, then this obligation shall be null and void, otherwise it shall remain in full force and effect. In the event suit is brought upon this bond by said OWNER and OWNER prevails, said Surety shall pay all costs incurred by said OWNER in such suit, including a reasonable attorney's fee to be fixed by the court.

SIGNED AND SEALED, this 24th day of February, 20 14

PAL General Engineering, Inc. (SEAL)

(Principal)

By:

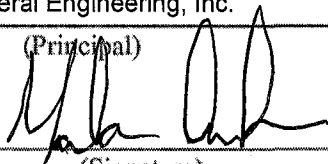

(Signature)

Marla Jahshan, President

The Hanover Insurance Company (SEAL)

(Surety)

By:

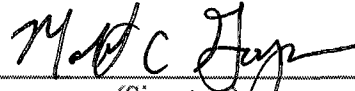

(Signature)

Matthew C. Gaynor, Attorney-In-Fact

(SEAL AND NOTARIAL ACKNOWLEDGEMENT OF SURETY)

**THE HANOVER INSURANCE COMPANY
MASSACHUSETTS BAY INSURANCE COMPANY
CITIZENS INSURANCE COMPANY OF AMERICA**

*POWERS OF ATTORNEY
CERTIFIED COPY*

KNOW ALL MEN BY THESE PRESENTS: That THE HANOVER INSURANCE COMPANY and MASSACHUSETTS BAY INSURANCE COMPANY, both being corporations organized and existing under the laws of the State of New Hampshire, and CITIZENS INSURANCE COMPANY OF AMERICA, a corporation organized and existing under the laws of the State of Michigan, do hereby constitute and appoint

Matthew C. Gaynor, Kim D. Vasquez, Daniel Frazee and/or David J. Garcia

of **Santee, CA** and each is a true and lawful Attorney(s)-in-fact to sign, execute, seal, acknowledge and deliver for, and on its behalf, and as its act and deed any place within the United States, or, if the following line be filled in, only within the area therein designated any and all bonds, recognizances, undertakings, contracts of indemnity or other writings obligatory in the nature thereof, as follows:

Any such obligations in the United States, not to exceed Ten Million and No/100 (\$10,000,000) in any single instance

and said companies hereby ratify and confirm all and whatsoever said Attorney(s)-in-fact may lawfully do in the premises by virtue of these presents. These appointments are made under and by authority of the following Resolution passed by the Board of Directors of said Companies which resolutions are still in effect:

"RESOLVED, That the President or any Vice President, in conjunction with any Vice President, be and they are hereby authorized and empowered to appoint Attorneys-in-fact of the Company, in its name and as its acts, to execute and acknowledge for and on its behalf as Surety any and all bonds, recognizances, contracts of indemnity, waivers of citation and all other writings obligatory in the nature thereof, with power to attach thereto the seal of the Company. Any such writings so executed by such Attorneys-in-fact shall be as binding upon the Company as if they had been duly executed and acknowledged by the regularly elected officers of the Company in their own proper persons." (Adopted October 7, 1981 - The Hanover Insurance Company; Adopted April 14, 1982 - Massachusetts Bay Insurance Company; Adopted September 7, 2001 - Citizens Insurance Company of America)

IN WITNESS WHEREOF, THE HANOVER INSURANCE COMPANY, MASSACHUSETTS BAY INSURANCE COMPANY and CITIZENS INSURANCE COMPANY OF AMERICA have caused these presents to be sealed with their respective corporate seals, duly attested by two Vice Presidents, this **7th** day of **December 2011**.



**THE HANOVER INSURANCE COMPANY
MASSACHUSETTS BAY INSURANCE COMPANY
CITIZENS INSURANCE COMPANY OF AMERICA**

Robert Thomas

Robert Thomas, Vice President

Joe Brenstrom

Joe Brenstrom, Vice President

THE COMMONWEALTH OF MASSACHUSETTS)
COUNTY OF WORCESTER) ss.

On this **7th** day of **December 2011** before me came the above named Vice Presidents of The Hanover Insurance Company, Massachusetts Bay Insurance Company and Citizens Insurance Company of America, to me personally known to be the individuals and officers described herein, and acknowledged that the seals affixed to the preceding instrument are the corporate seals of The Hanover Insurance Company, Massachusetts Bay Insurance Company and Citizens Insurance Company of America, respectively, and that the said corporate seals and their signatures as officers were duly affixed and subscribed to said instrument by the authority and direction of said Corporations.

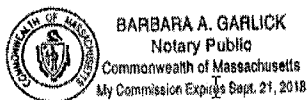

Barbara A. Garlick

Barbara A. Garlick, Notary Public
My Commission Expires September 21, 2018

I, the undersigned Vice President of The Hanover Insurance Company, Massachusetts Bay Insurance Company and Citizens Insurance Company of America, hereby certify that the above and foregoing is a full, true and correct copy of the Original Power of Attorney issued by said Companies, and do hereby further certify that the said Powers of Attorney are still in force and effect.

This Certificate may be signed by facsimile under and by authority of the following resolution of the Board of Directors of The Hanover Insurance Company, Massachusetts Bay Insurance Company and Citizens Insurance Company of America.

"RESOLVED, That any and all Powers of Attorney and Certified Copies of such Powers of Attorney and certification in respect thereto, granted and executed by the President or any Vice President in conjunction with any Vice President of the Company, shall be binding on the Company to the same extent as if all signatures therein were manually affixed, even though one or more of any such signatures thereon may be facsimile." (Adopted October 7, 1981 - The Hanover Insurance Company; Adopted April 14, 1982 - Massachusetts Bay Insurance Company; Adopted September 7, 2001 - Citizens Insurance Company of America)

GIVEN under my hand and the seals of said Companies, at Worcester, Massachusetts, this 24th day of February 2014.

**THE HANOVER INSURANCE COMPANY
MASSACHUSETTS BAY INSURANCE COMPANY
CITIZENS INSURANCE COMPANY OF AMERICA**

Glenn Margosian

Glenn Margosian, Vice President

ACKNOWLEDGMENT

State of California
County of San Diego)

On February 24, 2014 before me, Kathy Scheuerman, Notary Public
(insert name and title of the officer)

personally appeared Matthew C. Gaynor,
who proved to me on the basis of satisfactory evidence to be the person(s) whose name(s) is/are
subscribed to the within instrument and acknowledged to me that he/~~she~~/they executed the same in
his/~~her~~/their authorized capacity(~~ies~~), and that by his/~~her~~/their signature(s) on the instrument the
person(s), or the entity upon behalf of which the person(s) acted, executed the instrument.

I certify under PENALTY OF PERJURY under the laws of the State of California that the foregoing
paragraph is true and correct.

WITNESS my hand and official seal.

Signature Kathy Scheuerman (Seal)



State of California
County of San Diego

Subscribed and sworn to (or affirmed) before me on this 26th
day of February, 2014, by Marla Jahshan

_____,
proved to me on the basis of satisfactory evidence to be the
person(s) who appeared before me.



(Seal)

Signature _____

BIDDING DOCUMENTS

CONTRACTORS CERTIFICATION OF PENDING ACTIONS

As part of its bid or proposal (Non-Price Proposal in the case of Design-Build contracts), the Bidder shall provide to the City a list of all instances within the past 10 years where a complaint was filed or pending against the Bidder in a legal or administrative proceeding alleging that Bidder discriminated against its employees, subcontractors, vendors or suppliers, and a description of the status or resolution of that complaint, including any remedial action taken.

CHECK ONE BOX ONLY.

- The undersigned certifies that within the past 10 years the Bidder has NOT been the subject of a complaint or pending action in a legal administrative proceeding alleging that Bidder discriminated against its employees, subcontractors, vendors or suppliers.

- The undersigned certifies that within the past 10 years the Bidder has been the subject of a complaint or pending action in a legal administrative proceeding alleging that Bidder discriminated against its employees, subcontractors, vendors or suppliers. A description of the status or resolution of that complaint, including any remedial action taken and the applicable dates is as follows:

DATE OF CLAIM	LOCATION	DESCRIPTION OF CLAIM	LITIGATION (Y/N)	STATUS	RESOLUTION/REMEDIAL ACTION TAKEN

Contractor Name: PAL General Engineering, Inc.

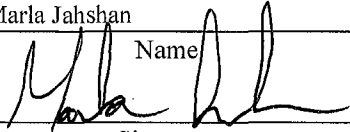
Certified By Marla Jahshan Title President

 Name Signature Date 2/26/14

USE ADDITIONAL FORMS AS NECESSARY

BIDDING DOCUMENTS

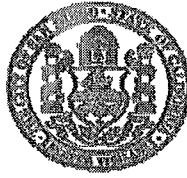
**EQUAL BENEFITS ORDINANCE
CERTIFICATION OF COMPLIANCE**



For additional information, contact:
CITY OF SAN DIEGO
EQUAL BENEFITS PROGRAM
 202 C Street, MS 9A, San Diego, CA 92101
 Phone (619) 533-3948 Fax (619) 533-3220

COMPANY INFORMATION	
Company Name: PAL General Engineering, Inc.	Contact Name: Marla Jahshan
Company Address: 5374 Eastgate Mall	Contact Phone: (858) 638-7100
San Diego, CA 92121	Contact Email: info@palsd.com

CONTRACT INFORMATION	
Contract Title: FY'14 SIDEWALK REPLACEMENT GROUP 2	Start Date: TBD
Contract Number (if no number, state location): San Diego, CA	End Date: TBD

SUMMARY OF EQUAL BENEFITS ORDINANCE REQUIREMENTS

The Equal Benefits Ordinance [EBO] requires the City to enter into contracts only with contractors who certify they will provide and maintain equal benefits as defined in SDMC §22.4302 for the duration of the contract. To comply:

- Contractor shall offer equal benefits to employees with spouses and employees with domestic partners.
 - Benefits include health, dental, vision insurance; pension/401(k) plans; bereavement, family, parental leave; discounts, child care; travel/relocation expenses; employee assistance programs; credit union membership; or any other benefit.
 - Any benefit not offer an employee with a spouse, is not required to be offered to an employee with a domestic partner.
- Contractor shall post notice of firm's equal benefits policy in the workplace and notify employees at time of hire and during open enrollment periods.
- Contractor shall allow City access to records, when requested, to confirm compliance with EBO requirements.
- Contractor shall submit *EBO Certification of Compliance*, signed under penalty of perjury, prior to award of contract.

NOTE: This summary is provided for convenience. Full text of the EBO and Rules Implementing the EBO are available at www.sandiego.gov/administration.

CONTRACTOR EQUAL BENEFITS ORDINANCE CERTIFICATION

Please indicate your firm's compliance status with the EBO. The City may request supporting documentation.

I affirm **compliance** with the EBO because my firm (*contractor must select one reason*):

- Provides equal benefits to spouses and domestic partners.
- Provides no benefits to spouses or domestic partners.
- Has no employees.
- Has collective bargaining agreement(s) in place prior to January 1, 2011, that has not been renewed or expired.

I request the City's approval to pay affected employees a cash equivalent in lieu of equal benefits and verify my firm made a reasonable effort but is not able to provide equal benefits upon contract award. I agree to notify employees of the availability of a cash equivalent for benefits available to spouses but not domestic partners and to continue to make every reasonable effort to extend all available benefits to domestic partners.

It is unlawful for any contractor to knowingly submit any false information to the City regarding equal benefits or cash equivalent associated with the execution, award, amendment, or administration of any contract. [San Diego Municipal Code §22.4307(a)]

Under penalty of perjury under laws of the State of California, I certify the above information is true and correct. I further certify that my firm understands the requirements of the Equal Benefits Ordinance and will provide and maintain equal benefits for the duration of the contract or pay a cash equivalent if authorized by the City.

Marla Jahshan, President		2/26/14
Name/Title of Signatory	Signature	Date

FOR OFFICIAL CITY USE ONLY

Receipt Date: _____ EBO Analyst: _____ Approved Not Approved – Reason: _____

(Rev 02/15/2011)

BIDDING DOCUMENTS

PROPOSAL (BID)

The Bidder agrees to the construction of **FY'14 Sidewalk Replacement Group 2**, for the City of San Diego, in accordance with these contract documents for the prices listed below. The Bidder guarantees the Contract Price for a period of 120 days (90 days for federally funded contracts and contracts valued at \$500,000 or less) from the date of Bid opening to Award of the Contract. The duration of the Contract Price guarantee shall be extended by the number of days required for the City to obtain all items necessary to fulfill all conditions precedent e.g., bond and insurance.

Item	Quantity	Unit	NAICS	Payment Reference	Description	Unit Price	Extension
BASE BID							
1	1	LS	524126	2-4.1	Bonds (Payment and Performance)	 	\$ 4,000.00
2	1	LS	237310	7-10.2.6	Traffic Control	 	\$ 8,000.00
3	1	AL		9-3.5	Field Orders - Type II Allowance	 	\$30,000.00
4	1,500	SF	238910	300-1.4	Miscellaneous Hardscape, Remove & Replace with Topsoil	\$6.00	\$ 9,000.00
5	10	EA	237310	303-5.9	Contractor Date Stamp and Impressions	\$ 150.00	\$ 1,500.00
6	600	LF	237310	303-5.9	Type 'G' Curb & Gutter, Remove & Replace	\$ 28.00	\$ 16,800.00
7	2,200	SF	237310	303-5.9	Residential Concrete Driveway, Remove & Replace	\$ 7.50	\$ 16,500.00
8	25,000	SF	237310	303-5.9	Existing Sidewalk, Remove and Replace	\$ 6.35	\$ 158,750.00
9	12	EA	237310	303-5.10.2	Curb Ramp Type C1 or C2 w/Composite Detectable Warning Tiles	\$ 1,950.00	\$ 23,400.00
10	5	EA	237310	303-5.10.2	Curb Ramp Type A or B w/Composite Detectable Warning Tiles	\$ 1,875.00	\$ 9,375.00
11	7	EA	237310	303-5.10.2	Curb Ramp Type D w/Composite Detectable Warning Tiles	\$ 1,850.00	\$ 12,950.00
12	50	EA	561730	308-7	Remove & Dispose (Small Tree; less than 24" dia)	\$ 442.00	\$ 22,100.00

BIDDING DOCUMENTS

Item	Quantity	Unit	NAICS	Payment Reference	Description	Unit Price	Extension
13	10	EA	561730	308-7	Remove & Dispose (Large Tree; greater than 24" dia)	\$ 1,242.00	\$ 12,420.00
14	50	EA	561730	308-7	Tree Planting	\$ 213.00	\$ 10,650.00
15	120	EA	561730	308-7	Tree Trimming	\$ 121.00	\$ 14,520.00
16	150	EA	561730	308-7	Root Pruning & Root Barrier (15 F Segments)	\$ 193.00	\$ 28,950.00
17	1	LS	541330	701-13.9.5	Water Pollution Control Program Development	X	\$ 1,000.00
18	1	LS	237990	701-13.9.5	Water Pollution Control Program Implementation	X	\$ 3,500.00
ESTIMATED TOTAL BASE BID:							\$ 383,415.00

TOTAL BID PRICE FOR BID (Items 1 through 18 inclusive) amount written in words:

Three Hundred Eighty Three Thousand, Four Hundred Fifteen Dollars and zero cents.

The Bid shall contain an acknowledgment of receipt of all addenda, the numbers of which shall be filled in on the Bid form. If an addendum or addenda has been issued by the City and not noted as being received by the Bidder, this proposal shall be rejected as being **non-responsive**. The following addenda have been received and are acknowledged in this bid: NONE

The names of all persons interested in the foregoing proposal as principals are as follows:

Marla Jahshan, President

Abd Jahshan, Vice President

BIDDING DOCUMENTS

IMPORTANT NOTICE: If Bidder or other interested person is a corporation, state secretary, treasurer, and manager thereof; if a co-partnership, state true name of firm, also names of all individual co-partners composing firm; if Bidder or other interested person is an individual, state first and last names in full.

Bidder: PAL General Engineering, Inc.

Title: President

Business Address: 5374 Eastgate Mall

Place of Business: San Diego, CA 92121

Place of Residence: San Diego, CA

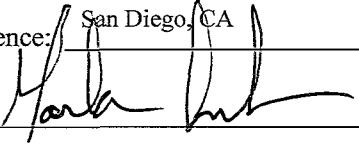
Signature: 

NOTES:

- A. The City shall determine the low Bid based on the Base Bid alone.
- B. Prices and notations shall be in ink or typewritten. All corrections (which have been initiated by the Bidder using erasures, strike out, line out, or "white-out") shall be typed or written in with ink adjacent thereto, and shall be initialed in ink by the person signing the bid proposal.
- C. Failure to initial all corrections made in the bidding documents may cause the Bid to be rejected as **non-responsive** and ineligible for further consideration.
- D. Blank spaces must be filled in, using figures. Bidder's failure to submit a price for any Bid item that requires the Bidder to submit a price shall render the Bid **non-responsive** and shall be cause for its rejection.
- E. Unit prices shall be entered for all unit price items. Unit prices shall not exceed two (2) decimal places. If the Unit prices entered exceed two (2) decimal places, the City will only use the first two digits after the decimal points without rounding up or down.
- F. All extensions of the unit prices bid will be subject to verification by the City. In the case of inconsistency or conflict between the product of the Quantity x Unit Price and the Extension, the product shall govern.
- G. In the case of inconsistency or conflict, between the sums of the Extensions with the estimated total Bid, the sum of the Extensions shall govern.
- H. Bids shall not contain any recapitulation of the Work. Conditional Bids will be rejected as being **non-responsive**. Alternative proposals will not be considered unless called for.

BIDDING DOCUMENTS

LIST OF SUBCONTRACTORS

In accordance with the requirements provided in the "Subletting and Subcontracting Fair Practices Act", Division 2, Part 1, Chapter 4 of the Public Contract Code, the Bidder shall list below the name and address of each Subcontractor who will perform work, labor, render services or specially fabricates and installs a portion [type] of the work or improvement, in an amount in excess of 0.5% of the Contractor's total Bid. The Bidder shall also list below the portion of the work which will be done by each subcontractor under this Contract. The Contractor shall list only one Subcontractor for each portion of the Work. The **DOLLAR VALUE** of the total Bid to be performed shall be stated for all subcontractors listed. Failure to comply with this requirement shall result in the Bid being rejected as **non-responsive** and ineligible for award. The Bidder's attention is directed to the Special Provisions - General; Paragraph 2-3 Subcontracts, which stipulates the percent of the Work to be performed with the Bidders' own forces. The Bidder shall list all SLBE, ELBE, DBE, DVBE, MBE, WBE, OBE, SDB, WoSB, HUBZone, and SDVOSB Subcontractors that Bidders are seeking recognition towards achieving any mandatory, voluntary, or both subcontracting participation percentages.

NAME, ADDRESS AND TELEPHONE NUMBER OF SUBCONTRACTOR	CONSTRUCTOR OR DESIGNER	TYPE OF WORK	DOLLAR VALUE OF SUBCONTRACT	MBE, WBE, DBE, DVBE, OBE, ELBE, SLBE, SDB, WoSB, HUBZone, OR SDVOSB [ⓐ]	WHERE CERTIFIED [ⓑ]	CHECK IF JOINT VENTURE PARTNERSHIP
Name: <u>Green Horizons Landscape</u> Address: <u>1530 Industrial Ave</u> City: <u>San Diego</u> State: <u>CA</u> Zip: <u>92029</u> Phone: <u>(760) 745-1776</u>	Constructor	Landscape	\$77,100.00	N/A	N/A	N/A
Name: _____ Address: _____ City: _____ State: _____ Zip: _____ Phone: _____						
Name: _____ Address: _____ City: _____ State: _____ Zip: _____ Phone: _____						

ⓐ As appropriate, Bidder shall identify Subcontractor as one of the following and shall include a valid proof of certification (except for OBE, SLBE and ELBE):

- | | | | |
|---|--------|--|---------|
| Certified Minority Business Enterprise | MBE | Certified Woman Business Enterprise | WBE |
| Certified Disadvantaged Business Enterprise | DBE | Certified Disabled Veteran Business Enterprise | DVBE |
| Other Business Enterprise | OBE | Certified Emerging Local Business Enterprise | ELBE |
| Certified Small Local Business Enterprise | SLBE | Small Disadvantaged Business | SDB |
| Woman-Owned Small Business | WoSB | HUBZone Business | HUBZone |
| Service-Disabled Veteran Owned Small Business | SDVOSB | | |

ⓑ As appropriate, Bidder shall indicate if Subcontractor is certified by:

- | | | | |
|--|--------|--|----------|
| City of San Diego | CITY | State of California Department of Transportation | CALTRANS |
| California Public Utilities Commission | CPUC | San Diego Regional Minority Supplier Diversity Council | SRMSDC |
| State of California's Department of General Services | CADoGS | City of Los Angeles | LA |
| State of California | CA | U.S. Small Business Administration | SBA |

The Bidder will not receive any subcontracting participation percentages if the Bidder fails to submit the required proof of certification.

2011
CA

BIDDING DOCUMENTS

NAMED EQUIPMENT/MATERIAL SUPPLIER LIST

The Bidder seeking the recognition of equipment, materials, or supplies obtained from Suppliers towards achieving any mandatory, voluntary, or both subcontracting participation percentages shall list the Supplier(s) on the Named Equipment/Material Supplier List. The Named Equipment/Material Supplier List, at a minimum, shall have the name, locations (City) and the **DOLLAR VALUE** of the Suppliers. The Bidder will be credited up to 60% of the amount to be paid to the Suppliers for such materials and supplies unless vendor manufactures or substantially alters materials and supplies in which case 100% will be credited. The Bidder is to indicate (Yes/No) whether listed firm is a supplier or manufacturer. In calculating the subcontractor participation percentages, vendors/suppliers will receive 60% credit of the listed **DOLLAR VALUE**, whereas manufacturers will receive 100% credit. If no indication provided, listed firm will be credited at 60% of the listed dollar value for purposes of calculating the Subcontractor Participation Percentage, Suppliers will receive 60% credit of the listed **DOLLAR VALUE**, whereas manufacturers will receive 100% credit. If no indication provided, listed firm will be credited at 60% of the listed **DOLLAR VALUE** for purposes of calculating the subcontractor participation percentages.

NAME, ADDRESS AND TELEPHONE NUMBER OF VENDOR/SUPPLIER	MATERIALS OR SUPPLIES	DOLLAR VALUE OF MATERIAL OR SUPPLIES	SUPPLIER (Yes/No)	MANUFACTURER (Yes/No)	MBE, WBE, DBE, DVBE, OBE, ELBE, SLBE, SDB, WoSB, HUBZone, OR SDVOSB [Ⓛ]	WHERE CERTIFIED [Ⓛ]
Name: _____ Address: _____ City: _____ State: _____ Zip: _____ Phone: _____	N/A					
Name: _____ Address: _____ City: _____ State: _____ Zip: _____ Phone: _____						
Name: _____ Address: _____ City: _____ State: _____ Zip: _____ Phone: _____						

Ⓛ As appropriate, Bidder shall identify Vendor/Supplier as one of the following and shall include a valid proof of certification (except for OBE,SLBE and ELBE):

- | | | | |
|---|--------|--|---------|
| Certified Minority Business Enterprise | MBE | Certified Woman Business Enterprise | WBE |
| Certified Disadvantaged Business Enterprise | DBE | Certified Disabled Veteran Business Enterprise | DVBE |
| Other Business Enterprise | OBE | Certified Emerging Local Business Enterprise | ELBE |
| Certified Small Local Business Enterprise | SLBE | Small Disadvantaged Business | SDB |
| Woman-Owned Small Business | WoSB | HUBZone Business | HUBZone |
| Service-Disabled Veteran Owned Small Business | SDVOSB | | |

Ⓛ As appropriate, Bidder shall indicate if Vendor/Supplier is certified by:

- | | | | |
|--|--------|--|----------|
| City of San Diego | CITY | State of California Department of Transportation | CALTRANS |
| California Public Utilities Commission | CPUC | San Diego Regional Minority Supplier Diversity Council | SRMSDC |
| State of California's Department of General Services | CADoGS | City of Los Angeles | LA |
| State of California | CA | U.S. Small Business Administration | SBA |

The Bidder will not receive any subcontracting participation percentages if the Bidder fails to submit the required proof of certification.