

# City of San Diego

CONTRACTOR'S NAME: \_\_\_\_\_  
ADDRESS: \_\_\_\_\_  
TELEPHONE NO.: \_\_\_\_\_ FAX NO.: \_\_\_\_\_  
CITY CONTACT: Damian Singleton, Contract Specialist, Email: [Dsingleton@sandiego.gov](mailto:Dsingleton@sandiego.gov)  
Phone No. (619) 533-3482, Fax No. (619) 533-3633  
J.Gallardo/B.Doringo/egz

## CONTRACT DOCUMENTS



## FOR

### BOUNDARY ST & EDMONTON AVE SMR

VOLUME 1 OF 2

BID NO.: \_\_\_\_\_ K-15-1217-DBB-3  
SAP NO. (WBS/IO/CC): \_\_\_\_\_ B-13173  
CLIENT DEPARTMENT: \_\_\_\_\_ 2011  
COUNCIL DISTRICT: \_\_\_\_\_ 1, 9  
PROJECT TYPE: \_\_\_\_\_ JA

**THIS CONTRACT IS SUBJECT TO THE FOLLOWING:**

- THE CITY'S SUBCONTRACTING PARTICIPATION REQUIREMENTS FOR SLBE PROGRAM.
- BID DISCOUNT PROGRAM (The WHITEBOOK, SLBE-ELBE Program Requirements, Section IV(2))
- PREVAILING WAGE RATES: STATE  FEDERAL

**BID DUE DATE:**

**2:00 PM  
NOVEMBER 11, 2014  
CITY OF SAN DIEGO  
PUBLIC WORKS CONTRACTS  
1010 SECOND AVENUE, 14<sup>th</sup> FLOOR, MS 614C  
SAN DIEGO, CA 92101**

# ENGINEER OF WORK

The engineering Specifications and Special Provisions contained herein have been prepared by or under the direction of the following Registered Engineer:

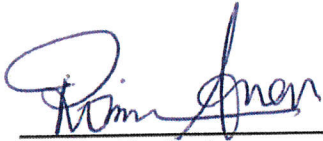
  
\_\_\_\_\_  
For City Engineer

9/4/2014  
\_\_\_\_\_  
Date

Seal



## TABLE OF CONTENTS

DESCRIPTION	PAGE NUMBER
1. NOTICE INVITING BIDS.....	4
2. CONTRACT FORMS .....	15
3. CONTRACT FORMS ATTACHMENTS:	
1. Performance Bond and Labor and Materialmen’s Bond .....	19
2. Drug-Free Workplace.....	21
3. American with Disabilities Act (ADA) Compliance Certification .....	22
4. Contractor Standards - Pledge of Compliance Certificate .....	23
5. Affidavit of Disposal Certificate .....	24
4. ATTACHMENTS:	
A. SCOPE OF WORK .....	26
B. INTENTIONALLY LEFT BLANK.....	28
C. EQUAL OPPORTUNITY CONTRACTING PROGRAM .....	29
D. INTENTIONALLY LEFT BLANK.....	33
E. SUPPLEMENTARY SPECIAL PROVISIONS .....	34
SUPPLEMENTARY SPECIAL PROVISIONS APPENDICES .....	60
1. Appendix A – Notice of Exemption.....	61
2. Appendix B - Fire Hydrant Meter Program .....	64
3. Appendix C - Materials Typically Accepted by Certificate of Compliance .....	78
4. Appendix D - Sample City Invoice .....	80
5. Appendix E - Location Map.....	82
6. Appendix F – Rehab Data Collection – Sewer Mains and Manholes .....	84
F. INTENTIONALLY LEFT BLANK.....	87

# CITY OF SAN DIEGO, CALIFORNIA

## NOTICE INVITING BIDS

1. **RECEIPT AND OPENING OF BIDS:** Bids will be received at the Public Works Contracts at the location, time, and date shown on the cover of these specifications for performing work on **Boundary St & Edmonton Ave SMR** (Project).
2. **SUMMARY OF WORK:** The Work involves furnishing all labor, materials, equipment, services, and other incidental works and appurtenances for the construction of the Project as described in ATTACHMENT A.
3. **BIDS ARE PUBLIC RECORDS:** Upon receipt by the City, Bids shall become public records subject to public disclosure. It is the responsibility of the respondent to clearly identify any confidential, proprietary, trade secret or otherwise legally privileged information contained within the Bid. General references to sections of the California Public Records Act (PRA) will not suffice. If the Contractor does not provide applicable case law that clearly establishes that the requested information is exempt from the disclosure requirements of the PRA, the City shall be free to release the information when required in accordance with the PRA, pursuant to any other applicable law, or by order of any court or government agency, and the Contractor will hold the City harmless for release of this information.
4. **SUBCONTRACTING PARTICIPATION PERCENTAGES:**
  - 4.1. The City has incorporated **mandatory** SLBE-ELBE subcontractor participation percentages to enhance competition and maximize subcontracting opportunities. For the purpose of achieving the mandatory subcontractor participation percentages, a recommended breakdown of the SLBE and ELBE subcontractor participation percentages based upon certified SLBE and ELBE firms has also been provided to achieve the mandatory subcontractor participation percentages:

1. SLBE participation	<b>6.4%</b>
2. ELBE participation	<b>15.9%</b>
3. Total mandatory participation	<b>22.3%</b>
  - 4.2. The Bidders are strongly encouraged to attend the Pre-Bid Meeting to better understand the Good Faith Effort requirements of this contract. See the City's document titled "SLBE Program, Instructions For Bidders Completing The Good Faith Effort Submittal" available at: <http://www.sandiego.gov/eoc/>
  - 4.3. The Bid will be declared non-responsive if the Bidder fails the following mandatory conditions:
    - 4.3.1. Bidder's inclusion of SLBE-ELBE certified subcontractors at the overall mandatory participation percentage identified in this document; OR.
    - 4.3.2. Bidder's submission of Good Faith Effort documentation demonstrating the Bidder made a good faith effort to outreach to and include SLBE-ELBE Subcontractors required in this document within **3 Working Days** of the Bid opening if the overall mandatory participation percentage is not met.

- 4.4. For additional Equal Opportunity Contracting Program requirements, see Attachment C.
5. **PRE-BID MEETING:**
- 5.1. There will be a Pre-Bid Meeting to discuss the scope of the Project, bidding requirements, pre-qualification process, and Equal Opportunity Contracting Program requirements and reporting procedures in the Public Works Contracts, Conference Room at 1010 Second Avenue, 14<sup>th</sup> Floor, San Diego, CA 92101 **at 10:00 AM, on OCTOBER 15, 2014.**
- 5.2. All potential bidders are encouraged to attend.
- 5.3. To request a copy of the agenda on an alternative format, or to request a sign language or oral interpreter for this meeting, call the Public Works Contracts at (619) 533-3450 at least 5 Working Days prior to the Pre-Bid Meeting to ensure availability.
6. **CONTRACTOR REGISTRATION AND ELECTRONIC REPORTING SYSTEM:**
- 6.1. **Prior** to the Award of the Contract or each Task Order, you and your Subcontractors and Suppliers must register with the City's web-based contract compliance website, Prism®, located here:
- <https://pro.prismcompliance.com/default.aspx>.
- 6.2. The City may not award the contract until registration of all subcontractors and suppliers is complete. In the event this requirement is not met within the time frame specified in the Notice of Intent to Award letter, the City reserves the right to rescind the Notice of Award / Intent to Award and to make the award to the next responsive and responsible bidder / proposer.
7. **JOINT VENTURE CONTRACTORS:** Provide a copy of the Joint Venture agreement and the Joint Venture license to the City within 10 Working Days after receiving the Contract forms. See 2-1.1.2, "Joint Venture Contractors" in The WHITEBOOK for details.
8. **PREVAILING WAGE RATES:** Pursuant to San Diego Municipal Code section 22.3019, construction, alteration, demolition, repair and maintenance work performed under this Contract is subject to State prevailing wage laws. For construction work performed under this Contract cumulatively exceeding \$25,000 and for alteration, demolition, repair and maintenance work performed under this Contract cumulatively exceeding \$15,000, the Contractor and its subcontractors shall comply with State prevailing wage laws including, but not limited to, the requirements listed below.
- 8.1. **Compliance with Prevailing Wage Requirements.** Pursuant to sections 1720 through 1861 of the California Labor Code, the Contractor and its subcontractors shall ensure that all workers who perform work under this Contract are paid not less than the prevailing rate of per diem wages as determined by the Director of the California Department of Industrial Relations (DIR). This includes work performed during the design and preconstruction phases of construction including, but not limited to, inspection and land surveying work.

- 8.2.** Copies of such prevailing rate of per diem wages are on file at the City and are available for inspection to any interested party on request. Copies of the prevailing rate of per diem wages also may be found at <http://www.dir.ca.gov/OPRL/DPreWageDetermination.htm>. Contractor and its subcontractors shall post a copy of the prevailing rate of per diem wages determination at each job site and shall make them available to any interested party upon request.
- 8.3.** The wage rates determined by the DIR refer to expiration dates. If the published wage rate does not refer to a predetermined wage rate to be paid after the expiration date, then the published rate of wage shall be in effect for the life of this Contract. If the published wage rate refers to a predetermined wage rate to become effective upon expiration of the published wage rate and the predetermined wage rate is on file with the DIR, such predetermined wage rate shall become effective on the date following the expiration date and shall apply to this Contract in the same manner as if it had been published in said publication. If the predetermined wage rate refers to one or more additional expiration dates with additional predetermined wage rates, which expiration dates occur during the life of this Contract, each successive predetermined wage rate shall apply to this Contract on the date following the expiration date of the previous wage rate. If the last of such predetermined wage rates expires during the life of this Contract, such wage rate shall apply to the balance of the Contract.
- 8.4. Penalties for Violations.** Contractor and its subcontractors shall comply with California Labor Code section 1775 in the event a worker is paid less than the prevailing wage rate for the work or craft in which the worker is employed.
- 8.5. Payroll Records.** Contractor and its subcontractors shall comply with California Labor Code section 1776, which generally requires keeping accurate payroll records, verifying and certifying payroll records, and making them available for inspection. Contractor shall require its subcontractors to also comply with section 1776. Contractor and its subcontractors shall submit weekly certified payroll records online via the City's web-based Labor Compliance Program. Contractor is responsible for ensuring its subcontractors submit certified payroll records to the City.
- 8.6. Apprentices.** Contractor and its subcontractors shall comply with California Labor Code sections 1777.5, 1777.6 and 1777.7 concerning the employment and wages of apprentices. Contractor shall be held responsible for the compliance of their subcontractors with sections 1777.5, 1777.6 and 1777.7.
- 8.7. Working Hours.** Contractor and subcontractors shall comply with California Labor Code sections 1810 through 1815, including but not limited to: (i) restrict working hours on public works contracts to eight hours a day and forty hours a week, unless all hours worked in excess of 8 hours per day are compensated at not less than 1½ times the basic rate of pay; and (ii) specify penalties to be imposed on design professionals and subcontractors of \$25 per worker per day for each day the worker works more than 8 hours per day and 40 hours per week in violation of California Labor Code sections 1810 through 1815.
- 8.8. Required Provisions for Subcontracts.** Contractor shall include at a minimum a copy of the following provisions in any contract they enter into with a subcontractor: California Labor Code sections 1771, 1775, 1776, 1777.5, 1810, 1813, 1815, 1860 and 1861.

**8.9. Labor Code Section 1861 Certification.** Contractor in accordance with California Labor Code section 3700 is required to secure the payment of compensation of its employees and by signing this Contract, Contractor certifies that “I am aware of the provisions of Section 3700 of the California Labor Code which require every employer to be insured against liability for workers’ compensation or to undertake self-insurance in accordance with the provisions of that code, and I will comply with such provisions before commencing the performance of the work of this Contract.”

**8.10. Labor Compliance Program.** The City has its own Labor Compliance Program as authorized by the DIR. The City will withhold contract payments when payroll records are delinquent or deemed inadequate by the City or other governmental entity, or it has been established after an investigation by the City or other governmental entity that underpayment(s) have occurred.

**9. INSURANCE REQUIREMENTS:**

**9.1.** All certificates of insurance and endorsements required by the contract are to be provided upon issuance of the City’s Notice of Intent to Award letter.

**9.2.** Refer to sections 7-3, “LIABILITY INSURANCE”, and 7-4, “WORKERS’ COMPENSATION INSURANCE” of the Supplementary Special Provisions (SSP) for the insurance requirements which must be met.

**10. PREQUALIFICATION OF CONTRACTORS:**

**10.1.** Contractors submitting Bid must be pre-qualified for the total amount proposed, inclusive of all alternate items prior to the date of submittal. Bids from contractors who have not been pre-qualified as applicable and Bids that exceed the maximum dollar amount at which contractors are pre-qualified will be deemed **non-responsive** and ineligible for award. Complete information and prequalification questionnaires are available at:

<http://www.sandiego.gov/cip/bidopps/prequalification.shtml>

**10.2.** The completed questionnaire, financial statement, and bond letter or a copy of the contractor’s SLBE-ELBE certification and bond letter, must be submitted no later than 2 weeks prior to the bid opening to the Public Works Contracts, Prequalification Program, 1010 Second Avenue, 14<sup>th</sup> Floor, San Diego, CA 92101. For additional information or the answer to questions about the prequalification program, contact David Stucky at 619-533-3474 or [dstucky@sandiego.gov](mailto:dstucky@sandiego.gov).

**11. REFERENCE STANDARDS:** Except as otherwise noted or specified, the Work shall be completed in accordance with the following standards:

Title	Edition	Document Number
Standard Specifications for Public Works Construction (“The GREENBOOK”)	2012	PITS070112-01
City of San Diego Standard Specifications for Public Works Construction (“The WHITEBOOK”)*	2012	PITS070112-02

Title	Edition	Document Number
City of San Diego Standard Drawings*	2012	PITS070112-03
Caltrans Standard Specifications	2010	PITS070112-04
Caltrans Standard Plans	2010	PITS070112-05
California MUTCD	2012	PITS070112-06
City Standard Drawings - Updates Approved For Use (when specified)*	Varies	Varies
Standard Federal Equal Employment Opportunity Construction Contract Specifications and the Equal Opportunity Clause Dated 09-11-84	1984	769023
NOTE: *Available online under Engineering Documents and References at: <a href="http://www.sandiego.gov/publicworks/edocref/index.shtml">http://www.sandiego.gov/publicworks/edocref/index.shtml</a>		

- 12. CITY'S RESPONSES AND ADDENDA:** The City at its option, may respond to any or all questions submitted in writing, via letter, or FAX in the form of an addendum. No oral comment shall be of any force or effect with respect to this solicitation. The changes to the Contract Documents through addendum are made effective as though originally issued with the Bid. The Bidders shall acknowledge the receipt of Addenda on the form provided for this purpose in the Bid.
- 13. CITY'S RIGHTS RESERVED:** The City reserves the right to cancel the Notice Inviting Bids at any time, and further reserves the right to reject submitted Bids, without giving any reason for such action, at its sole discretion and without liability. Costs incurred by the Bidder(s) as a result of preparing Bids under the Notice Inviting Bids shall be the sole responsibility of each bidder. The Notice Inviting Bids creates or imposes no obligation upon the City to enter a contract.
- 14. CONTRACT PRICING FORMAT:** This solicitation is for a Lump Sum contract with Unit Price provisions as set forth in the Bid Proposal Form(s), Volume 2.
- 15. SUBMITTAL OF "OR EQUAL" ITEMS:** See Section 4-1.6, "Trade Names or Equals" in The WHITEBOOK and as amended in the SSP.
- 16. AWARD PROCESS:**
- 16.1.** The Award of this contract is contingent upon the Contractor's compliance with all conditions precedent to Award.
  - 16.2.** Upon acceptance of a Bid, the City will prepare contract documents for execution within approximately 21 days of the date of the Bid opening and award the Contract approximately within 7 days of receipt of properly executed Contract, bonds, and insurance documents.
  - 16.3.** This contract will be deemed executed, and effective, only upon the signing of the Contract by the Mayor or designee of the City.



- 17. SUBCONTRACT LIMITATIONS:** The Bidder's attention is directed to Standard Specifications for Public Works Construction, Section 2-3, "SUBCONTRACTS" in The GREENBOOK and as amended in the SSP which requires the Contractor to self-perform not less than the amount specified. Failure to comply with this requirement shall render the Bid **non-responsive** and ineligible for award.
- 18. AVAILABILITY OF PLANS AND SPECIFICATIONS:** Contract Documents may be obtained by visiting the City's website: <http://www.sandiego.gov/cip/>. Plans and Specifications for this contract are also available for review in the office of the City Clerk or Public Works Contracts.
- 19. SUBMISSION OF QUESTIONS:**
- 19.1.** The Director (or designee), of the Public Works Department is the officer responsible for opening, examining, and evaluating the competitive Bids submitted to the City for the acquisition, construction and completion of any public improvement except when otherwise set forth in these documents. All questions related to this solicitation shall be submitted to:
- Public Works Contracts  
1010 Second Avenue, 14<sup>th</sup> Floor  
San Diego, California, 92101  
Attention: [Contract Specialist listed on the front cover hereof]
- OR:
- Email address of the Contract Specialist listed on the front cover hereof.
- 19.2.** Questions received less than 14 days prior to the date for opening of Bids may not be considered.
- 19.3.** Clarifications deemed by the City to be material shall be issued by Addenda and uploaded to the City's online bidding service.
- 19.4.** Only questions answered by formal written addenda will be binding. Oral and other interpretations or clarifications will be without legal effect. It is the Bidder's responsibility to become informed of any Addenda that have been issued and to include all such information in its Bid.
- 20. ELIGIBLE BIDDERS:** No person, firm, or corporation shall be allowed to make, file, or be interested in **more** than one (1) Bid for the same work unless alternate Bids are called for. A person, firm or corporation who has submitted a sub-proposal to a Bidder, or who has quoted prices on materials to a Bidder, is not hereby disqualified from submitting a sub-proposal or quoting prices to other Bidders or from submitting a Bid in its own behalf. Any Bidder who submits more than one bid will result in the rejection of all bids submitted.
- 21. SAN DIEGO BUSINESS TAX CERTIFICATE:** The Contractor and Subcontractors, not already having a City of San Diego Business Tax Certificate for the work contemplated shall secure the appropriate certificate from the City Treasurer, Civic Center Plaza, first floor and submit to the Contract Specialist upon request or as specified in the Contract Documents. Tax Identification numbers for both the Bidder and the listed Subcontractors must be submitted on the City provided forms with the Notice Inviting Bids and Contract forms.

**22. PROPOSAL FORMS:** Bid shall be made only upon the Bidding Documents i.e., Proposal form attached to and forming a part of the specifications. The signature of each person signing shall be in longhand.

**22.1.** Bidder shall complete and submit all pages in the "Bidding Document" Section (see Volume 2) as their Bid per the schedule given under "Required Documents Schedule," (see Volume 1). Bidder is requested to retain for their reference other portions of the Contract Documents that are not required to be submitted with the Bid. The entire specifications for the bid package do not need to be submitted with the bid.

**22.2.** The City may require any Bidder to furnish a statement of experience, financial responsibility, technical ability, equipment, and references.

**22.3.** Bids and certain other forms and documents as specified in the Volume 2 of 2 of the Contract Documents shall be enclosed in a sealed envelope and shall bear the title of the work and name of the Bidder and the appropriate State Contractors License designation which the Bidder holds.

**22.4.** Bids may be withdrawn by the Bidder prior to, but not after, the time fixed for opening of Bids.

**23. BIDDER'S GUARANTEE OF GOOD FAITH (BID SECURITY):**

**23.1.** With the exception of the contracts valued \$5,000 or less, JOC and Design-Build contracts, and contracts subject to the Small and Local Business Program of \$250,000 or less e.g., ELBE contracts, each Bidder shall accompany its Bid with either a cashier's check upon some responsible bank, or a check upon such bank properly certified or an approved corporate surety bond payable to the City of San Diego, for an amount of not less than 10% of the aggregate sum of the Bid, which check or bond, and the monies represented thereby shall be held by the City as a guarantee that the Bidder, if awarded the contract, will in good faith enter into such contract and furnish the required final bonds.

**23.2.** The Bidder agrees that in case of Bidder's refusal or failure to execute this contract and give required final bonds, the money represented by a cashier's or certified check shall remain the property of the City, and if the Bidder shall fail to execute this contract, the Surety agrees that it will pay to the City damages which the City may suffer by reason of such failure, not exceeding the sum of 10% of the amount of the Bid.

**23.3.** A Bid received without the specified bid security will be rejected as being **non-responsive**.

**24. AWARD OF CONTRACT OR REJECTION OF BIDS:**

**24.1.** This contract may be awarded to the lowest responsible and reliable Bidder.

**24.2.** Bidders shall complete the entire Bid schedule (also referred to as "schedule of prices" or Proposal form). Incomplete price schedules will be rejected as being non-responsive.

- 24.3. The City reserves the right to reject any or all Bids, and to waive any informality or technicality in Bids received and any requirements of these specifications as to bidding procedure.
- 24.4. Bidders will not be released on account of their errors of judgment. Bidders may be released only upon receipt by the City from the Bidder within 3 Working Days, excluding Saturdays, Sundays, and state holidays, after the opening of Bids, of written notice which includes proof of honest, credible, clerical error of material nature, free from fraud or fraudulent intent, and of evidence that reasonable care was observed in the preparation of the Bid.
- 24.5. A non-selected Bidder may protest award of the Contract to the selected Bidder by submitting a written "Notice of Intent to Protest" including supporting documentation which shall be received by Public Works Contracts no later than 10 days after the City's announcement of the selected Bidder or no later than 10 days from the date that the City issues notice of designation of a Bidder as non-responsible in accordance with San Diego Municipal Code Chapter 2, § 22.3029, "Protests of Contract Award."
- 24.6. The City of San Diego will not discriminate with regard to race, religious creed, color, national origin, ancestry, physical handicap, marital status, sex or age, in the award of contracts.
- 24.7. Each Bid package properly executed as required by these specifications shall constitute a firm offer, which may be accepted by the City within the time specified in the Proposal.
- 24.8. The City reserves the right to evaluate all Bids and determine the lowest Bidder on the basis of any proposed alternates, additive items or options, at its discretion that will be disclosed in the Volume 2 of 2.

**25. BID RESULTS:**

- 25.1. The Bid opening by the City shall constitute the public announcement of the Apparent Low Bidder. In the event that the Apparent Low Bidder is subsequently deemed non-responsive or non-responsible, a public announcement will be posted in the City's web page <http://www.sandiego.gov/cip/index.shtml>, with the name of the newly designated Apparent Low Bidder.
- 25.2. To obtain Bid results, either attend Bid opening, review the results on the City's web site, or provide a self-addressed, stamped envelope, referencing Bid number, and Bid tabulation will be mailed to you upon verification of extensions. Bid results cannot be given over the telephone.

**26. THE CONTRACT:**

- 26.1. The Bidder to whom award is made shall execute a written contract with the City of San Diego and furnish good and approved bonds and insurance certificates specified by the City within 14 days after receipt by Bidder of a form of contract for execution unless an extension of time is granted to the Bidder in writing.

- 26.2.** If the Bidder takes longer than 14 days to fulfill these requirements, then the additional time taken shall be added to the Bid guarantee. The Contract shall be made in the form adopted by the City, which includes the provision that no claim or suit whatsoever shall be made or brought by Contractor against any officer, agent, or employee of the City for or on account of anything done or omitted to be done in connection with this contract, nor shall any such officer, agent, or employee be liable hereunder.
- 26.3.** If the Bidder to whom the award is made fails to enter into the contract as herein provided, the award may be annulled and the Bidder's Guarantee of Good Faith will be subject to forfeiture. An award may be made to the next lowest responsible and reliable Bidder who shall fulfill every stipulation embraced herein as if it were the party to whom the first award was made.
- 26.4.** Pursuant to the San Diego City Charter section 94, the City may only award a public works contract to the lowest responsible and reliable Bidder. The City will require the Apparent Low Bidder to (i) submit information to determine the Bidder's responsibility and reliability, (ii) execute the Contract in form provided by the City, and (iii) furnish good and approved bonds and insurance certificates specified by the City within 14 Days, unless otherwise approved by the City, in writing after the Bidder receives notification from the City, designating the Bidder as the Apparent Low Bidder and formally requesting the above mentioned items.
- 26.5.** The award of the Contract is contingent upon the satisfactory completion of the above mentioned items and becomes effective upon the signing of the Contract by the Mayor or designee. If the Apparent Low Bidder does not execute the Contract or submit required documents and information, the City may award the Contract to the next lowest responsible and reliable Bidder who shall fulfill every condition precedent to award. A corporation designated as the Apparent Low Bidder shall furnish evidence of its corporate existence and evidence that the officer signing the Contract and bond for the corporation is duly authorized to do so.
- 27. EXAMINATION OF PLANS, SPECIFICATIONS, AND SITE OF WORK:** The Bidder shall examine carefully the Project Site, the Plans and Specifications, other materials as described in the Special Provisions, Section 2-7, and the proposal forms (e.g., Bidding Documents). The submission of a Bid shall be conclusive evidence that the Bidder has investigated and is satisfied as to the conditions to be encountered, as to the character, quality, and scope of Work, the quantities of materials to be furnished, and as to the requirements of the Bidding Documents Proposal, Plans, and Specifications.
- 28. CITY STANDARD PROVISIONS:** This contract is subject to the following standard provisions. See The WHITEBOOK for details.
- 28.1.** The City of San Diego Resolution No. R-277952 adopted on May 20, 1991 for a Drug-Free Workplace.
- 28.2.** The City of San Diego Resolution No. R-282153 adopted on June 14, 1993 related to the Americans with Disabilities Act.
- 28.3.** The City of San Diego Municipal Code §22.3004 for Pledge of Compliance.

- 28.4. The City of San Diego’s Labor Compliance Program and the State of California Labor Code §§1771.5(b) and 1776.
- 28.5. Sections 1777.5, 1777.6, and 1777.7 of the State of California Labor Code concerning the employment of apprentices by contractors and subcontractors performing public works contracts.
- 28.6. The City’s Equal Benefits Ordinance (EBO), Chapter 2, Article 2, Division 43 of The San Diego Municipal Code (SDMC).
- 28.7. The City’s Information Security Policy (ISP) as defined in the City’s Administrative Regulation 90.63.

**29. PRE-AWARD ACTIVITIES:**

- 29.1. The selected contractor by the City to execute a contract for this Work shall provide the information required within the time specified in “Required Documents,” of this bid package. Failure to provide the information within the time specified may result in the Bid being rejected as **non-responsive**.
- 29.2. If the Bid is rejected as non-responsive, the selected contractor by the City to execute a contract for this Work shall forfeit the required Bid. The decision that the selected contractor by the City to execute a contract for this Work is non-responsive for failure to provide the information required within the time specified shall be at the sole discretion of the City.

**30. REQUIRED DOCUMENT SCHEDULE:**

- 30.1. The Bidder’s attention is directed to the City’s Municipal Code §22.0807(e), (3)-(5) for important information regarding grounds for debarment for failure to submit required documentation.
- 30.2. The specified Equal Opportunity Contracting Program (EOCP) forms are available for download from the City’s web site at:

<http://www.sandiego.gov/eoc/forms/index.shtml>

ITEM	WHEN DUE	FROM	DOCUMENT TO BE SUBMITTED
1.	BID SUBMITTAL DATE/TIME	ALL BIDDERS	Bid
2.	BID SUBMITTAL DATE/TIME	ALL BIDDERS	Bid Bond
3.	BID SUBMITTAL DATE/TIME	ALL BIDDERS	Non-collusion Affidavit to be Executed By Bidder and Submitted with Bid under 23 USC 112 and PCC 7106
4.	BID SUBMITTAL DATE/TIME	ALL BIDDERS	Contractors Certification of Pending Actions
5.	BID SUBMITTAL DATE/TIME	ALL BIDDERS	Equal Benefits Ordinance Certification of Compliance
6.	BID SUBMITTAL DATE/TIME	ALL BIDDERS	Form AA35 - List of Subcontractors

ITEM	WHEN DUE	FROM	DOCUMENT TO BE SUBMITTED
7.	BID SUBMITTAL DATE/TIME	ALL BIDDERS	Form AA40 - Named Equipment/Material Supplier List
8.	WITHIN 3 WORKING DAYS OF BID OPENING	ALL BIDDERS	SLBE Good Faith Efforts Documentation
9.	WITHIN 3 WORKING DAYS OF BID OPENING WITH GOOD FAITH EFFORT DOCUMENTATION	ALL BIDDERS	Form AA60 – List of Work Made Available
10.	WITHIN 3 WORKING DAYS OF BID OPENING WITH GOOD FAITH EFFORT DOCUMENTATION	ALL BIDDERS	Proof of Valid DBE-MBE-WBE-DVBE Certification Status e.g., Certs.
11.	PRIOR TO PRE-CONSTRUCTION MEETING	LOW BIDDER	Contractor’s Experience and Past Project Documentation. See Section 500.
12.	PRIOR TO PRE-CONSTRUCTION MEETING	LOW BIDDER	<ul style="list-style-type: none"> <li>• Manufacturer Certification per Section 500-1.1.2.1</li> </ul>
13.	WITHIN 10 WORKING DAYS AFTER RECEIPT BY BIDDER OF CONTRACT FORMS	APPARENT LOW BIDDER	Names of the principal individual owners of the Apparent Low Bidder
14.	WITHIN 10 WORKING DAYS AFTER RECEIPT BY BIDDER OF CONTRACT FORMS	APPARENT LOW BIDDER	If the Contractor is a Joint Venture: <ul style="list-style-type: none"> <li>• Joint Venture Agreement</li> <li>• Joint Venture License</li> </ul>
15.	WITHIN 10 WORKING DAYS AFTER RECEIPT BY BIDDER OF CONTRACT FORMS	APPARENT LOW BIDDER	Form BB05 - Work Force Report
16.	WITHIN 10 WORKING DAYS AFTER RECEIPT BY BIDDER OF CONTRACT FORMS	APPARENT LOW BIDDER	Contract Forms - Agreement
17.	WITHIN 10 WORKING DAYS AFTER RECEIPT BY BIDDER OF CONTRACT FORMS	APPARENT LOW BIDDER	Contract Forms - Payment and Performance Bond
18.	WITHIN 10 WORKING DAYS AFTER RECEIPT BY BIDDER OF CONTRACT FORMS	APPARENT LOW BIDDER	Certificates of Insurance and Endorsements
19.	WITHIN 10 WORKING DAYS AFTER RECEIPT BY BIDDER OF CONTRACT FORMS	APPARENT LOW BIDDER	Contractor Certification - Drug-Free Workplace
20.	WITHIN 10 WORKING DAYS AFTER RECEIPT BY BIDDER OF CONTRACT FORMS	APPARENT LOW BIDDER	Contractor Certification - American with Disabilities Act
21.	WITHIN 10 WORKING DAYS AFTER RECEIPT BY BIDDER OF CONTRACT FORMS	APPARENT LOW BIDDER	Contractors Standards - Pledge of Compliance

**CONTRACT FORMS**  
**AGREEMENT**

# CONTRACT FORMS

---

## CONSTRUCTION CONTRACT

This contract is made and entered into between THE CITY OF SAN DIEGO, a municipal corporation, herein called "City", and PULLMAN ENGINEERING, INC herein called "Contractor" for construction of Boundary St & Edmonton Ave SMR, Bid No. K-15-1217-DBB-3, in the amount of FOUR HUNDRED FIFTY-SIX THOUSAND FOUR HUNDRED SIXTY-SIX DOLLARS AND 63/100 (\$456,466.63), which is comprised of the Base Bid alone.

IN CONSIDERATION of the payments to be made hereunder and the mutual undertakings of the parties hereto, City and Contractor agree as follows:

1. The following are incorporated into this contract as though fully set forth herein:
  - (a) The attached Faithful Performance and Payment Bonds.
  - (b) The attached Proposal included in the Bid documents by the Contractor.
  - (c) Reference Standards listed in the Notice Inviting Bids and the Supplementary Special Provisions (SSP).
  - (d) That certain documents entitled Boundary St & Edmonton Ave SMR, on file in the office of the Public Works Department as Document No. B-13173, as well as all matters referenced therein.
2. The Contractor shall perform and be bound by all the terms and conditions of this contract and in strict conformity therewith shall perform and complete in a good and workmanlike manner Boundary St & Edmonton Ave SMR, Bid Number K-15-1217-DBB-3, San Diego, California.
3. For such performances, the City shall pay to Contractor the amounts set forth at the times and in the manner and with such additions or deductions as are provided for in this contract, and the Contractor shall accept such payment in full satisfaction of all claims incident to such performances.
4. No claim or suit whatsoever shall be made or brought by Contractor against any officer, agent, or employee of the City for or on account of anything done or omitted to be done in connection with this contract, nor shall any such officer, agent, or employee be liable hereunder.
5. This contract is effective as of the date that the Mayor or designee signs the agreement.



**CONTRACT FORMS (continued)**

---

IN WITNESS WHEREOF, this Agreement is signed by the City of San Diego, acting by and through its Mayor or designee, pursuant to Municipal Code §22.3102 authorizing such execution.

**THE CITY OF SAN DIEGO**

**APPROVED AS TO FORM AND LEGALITY**

By 

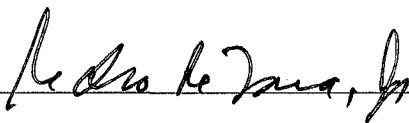
By 

Print Name: \_\_\_\_\_  
Stephen Samara  
Senior Contract Specialist

Print Name: Pedro DeLara, Jr.  
Deputy City Attorney

Date: 2-19-2015

Date: 2/20/15

**CONTRACTOR**

By 

Print Name: CHRIS PULLMAN

Title: Pres

Date: 12-8-2014

City of San Diego License No.: B1999010852

State Contractor's License No.: 770533

**CONTRACT FORMS**  
**ATTACHMENTS**

**CONTRACT FORMS ATTACHMENTS**  
**PERFORMANCE BOND AND LABOR AND MATERIALMEN'S BOND**

---

**FAITHFUL PERFORMANCE BOND AND LABOR AND MATERIALMEN'S BOND:**

PULLMAN ENGINEERING, INC., a corporation, as principal, and  
State National Insurance Company, Inc. administered by:  
Contractor Managing General Insurance Agency, Inc., a corporation authorized to do business  
in the State of California, as Surety, hereby obligate themselves, their successors and assigns, jointly and  
severally, to The City of San Diego a municipal corporation in the sum of  
FOUR HUNDRED FIFTY-SIX THOUSAND FOUR HUNDRED SIXTY-SIX DOLLARS AND  
63/100 (\$456,466.63) for the faithful performance of the annexed contract, and in the sum of FOUR  
HUNDRED FIFTY-SIX THOUSAND FOUR HUNDRED SIXTY-SIX DOLLARS AND  
63/100 (\$456,466.63) for the benefit of laborers and materialmen designated below.

**Conditions:**

If the Principal shall faithfully perform the annexed contract Boundary St & Edmonton Ave  
SMR, Bid Number K-15-1217-DBB-3, San Diego, California then the obligation herein with respect to a  
faithful performance shall be void; otherwise it shall remain in full force.

If the Principal shall promptly pay all persons, firms and corporations furnishing materials for or  
performing labor in the execution of this contract, and shall pay all amounts due under the California  
Unemployment Insurance Act then the obligation herein with respect to laborers and materialmen shall be  
void; otherwise it shall remain in full force.

The obligation herein with respect to laborers and materialmen shall inure to the benefit of all  
persons, firms and corporations entitled to file claims under the provisions of Chapter 3 of Division 5 of  
Title I of the Government Code of the State of California or under the provisions of Section 3082 et seq.  
of the Civil Code of the State of California.

Changes in the terms of the annexed contract or specifications accompanying same or referred to  
therein shall not affect the Surety's obligation on this bond, and the Surety hereby waives notice of same.

**CONTRACT FORMS ATTACHMENTS (continued)**  
**PERFORMANCE BOND AND LABOR AND MATERIALMEN'S BOND**

The Surety shall pay reasonable attorney's fees should suit be brought to enforce the provisions of this bond.

Dated December 4, 2014

Approved as to Form and Legality

Pullman Engineering, Inc.

Principal



SEE ATTACHED  
FOR NOTARY CERTIFICATE

By \_\_\_\_\_

CHRIS PULLMAN

Printed Name of Person Signing for Principal

Jan I. Goldsmith, City Attorney

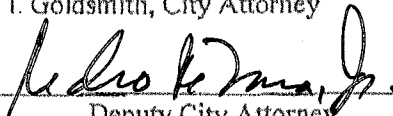
By   
Deputy City Attorney

State National Insurance Company, Inc. administered by:  
Contractor Managing General Insurance Agency, Inc.

Surety

By 

Attorney-in-fact  
Stephanie Hope Shear

Approved:

By   
Stephen Samara  
Senior Contract Specialist

20335 Ventura Blvd. Suite 426

Local Address of Surety

Woodland Hills, CA 91364

Local Address (City, State) of Surety

866-363-2642

Local Telephone No. of Surety

Premium \$ \$10,129.00

Bond No. CDGP101094

State National Insurance Company, Inc. Administered by:  
**CONTRACTOR MANAGING GENERAL INSURANCE AGENCY, INC.**

**POWER OF ATTORNEY**

KNOW BY ALL THESE PRESENTS That STATE NATIONAL INSURANCE COMPANY, INC. a corporation organized and existing under the laws of the State of Texas, having its principal office in Bedford, Texas does hereby constitute and appoint

Stephanie Hope Shear

its true and lawful attorney(s)-in-fact to execute, seal and deliver for and on its behalf as surety, the following bond described as:

Boundary st. & Edmonton Ave. SMR 5-15-1217-DBB-3

for: Three Million and 00/100 Dollars (\$3,000,000)

and undertakings, contracts of indemnity and other writings obligatory in the nature thereof, which are or may be allowed, required or permitted by law, statute, rule, regulation, contract or otherwise.

The execution of such instrument(s) in pursuance of these present, shall be as binding upon STATE NATIONAL INSURANCE COMPANY, INC. as fully and amply, to all intents and purposes, as if the same had been duly executed and acknowledged by its regularly elected officers at the principal office.

RESOLVED that the signature of any authorized officer and the seal of the Company may be affixed by facsimile to any Power of Attorney or certification thereof authorizing the execution and delivery of any bond, undertaking, contracts of indemnity and other writings obligatory in the nature thereof, and such signature and seal when so used shall have the same force and effect as though manually affixed.

IN WITNESS WHEREOF, STATE NATIONAL INSURANCE COMPANY, INC. has caused this instrument to be signed and its corporate seal to be affixed by its authorized officer, this 24th day of March, 2014.

STATE NATIONAL INSURANCE COMPANY, INC.

Terry L. Ledbetter, President

Trace Ledbetter, Secretary

STATE OF TEXAS  
County of Tarrant

On this 24th day of March, 2014 before me came the individuals who executed the preceding instrument, to me personally known, and being by me duly sworn, said that each of the herein described and authorized officer of STATE NATIONAL INSURANCE COMPANY, INC.; that the seal affixed to said instrument is the Corporate Seal of said Company; that the Corporate Seal and each signature were duly affixed by order of the Board of Directors of said Company.

IN WITNESS WHEREOF, I have hereunto set my hand at Bedford, Texas the day and year above written.

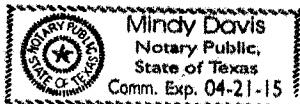

[Notary Stamp]

Signature of Notary

I, Trace Ledbetter, Secretary of STATE NATIONAL INSURANCE COMPANY, INC., do hereby certify that the above and foregoing is a true and correct copy of a Power of Attorney executed by STATE NATIONAL INSURANCE COMPANY, INC., which is still in full force and effect.

IN WITNESS WHEREOF, I have thereunto set my hand and attested the seal of said Company this 4th day of December, 2014

Trace Ledbetter, Secretary

**CALIFORNIA ALL – PURPOSE ACKNOWLEDGEMENT**

State of California

County of Los Angeles

On DEC 04 2014 before me, JAN MICHELLE RIVERA, NOTARY PUBLIC  
DATE NAME, TITLE OF OFFICER

Personally appeared STEPHANIE HOPE SHEAR,  
NAME(S) OF SIGNER(S)

Who proved to me on the basis of satisfactory evidence to be the person(s) whose name(s) is/are subscribed to the within instrument and acknowledged to me that he/she/they executed the same in his/her/their authorized capacity(ies), and that by his/her/their signature(s) on the instrument the person(s), or the entity upon behalf of which the person(s) acted, executed the instrument.

I certify under PENALTY OF PERJURY under the laws of the State of California that the foregoing paragraph is true and correct.

WITNESS my hand and official seal.

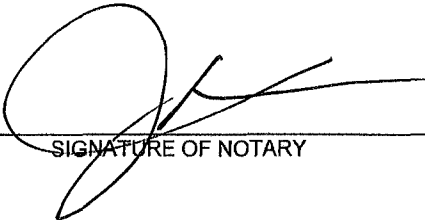
  
SIGNATURE OF NOTARY



NOTARY SEAL

# CALIFORNIA ALL-PURPOSE CERTIFICATE OF ACKNOWLEDGMENT

State of California

County of San Diego

On 12/12/14 before me, Tommie Richardson Notary Public,  
(Here insert name and title of the officer)

personally appeared Christopher Pullmer

who proved to me on the basis of satisfactory evidence to be the person(s) whose name(s) is/are subscribed to the within instrument and acknowledged to me that he/she/they executed the same in his/her/their authorized capacity(ies), and that by his/her/their signature(s) on the instrument the person(s), or the entity upon behalf of which the person(s) acted, executed the instrument.

I certify under PENALTY OF PERJURY under the laws of the State of California that the foregoing paragraph is true and correct.

WITNESS my hand and official seal.

[Signature]  
 Signature of Notary Public

(Notary Seal)

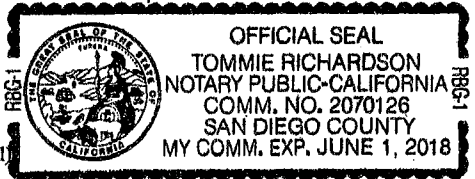

## ADDITIONAL OPTIONAL INFORMATION

**DESCRIPTION OF THE ATTACHED DOCUMENT**

\_\_\_\_\_

(Title or description of attached document)

\_\_\_\_\_

(Title or description of attached document continued)

Number of Pages \_\_\_\_\_ Document Date \_\_\_\_\_

\_\_\_\_\_

(Additional information)

**CAPACITY CLAIMED BY THE SIGNER**

Individual (s)

Corporate Officer

\_\_\_\_\_

(Title)

Partner(s)

Attorney-in-Fact

Trustee(s)

Other \_\_\_\_\_

- INSTRUCTIONS FOR COMPLETING THIS FORM**
- Any acknowledgment completed in California must contain verbiage exactly as appears above in the notary section or a separate acknowledgment form must be properly completed and attached to that document. The only exception is if a document is to be recorded outside of California. In such instances, any alternative acknowledgment verbiage as may be printed on such a document so long as the verbiage does not require the notary to do something that is illegal for a notary in California (i.e. certifying the authorized capacity of the signer). Please check the document carefully for proper notarial wording and attach this form if required.*
- State and County information must be the State and County where the document signer(s) personally appeared before the notary public for acknowledgment.
  - Date of notarization must be the date that the signer(s) personally appeared which must also be the same date the acknowledgment is completed.
  - The notary public must print his or her name as it appears within his or her commission followed by a comma and then your title (notary public).
  - Print the name(s) of document signer(s) who personally appear at the time of notarization.
  - Indicate the correct singular or plural forms by crossing off incorrect forms (i.e. ~~he/she/they~~ is /are ) or circling the correct forms. Failure to correctly indicate this information may lead to rejection of document recording.
  - The notary seal impression must be clear and photographically reproducible. Impression must not cover text or lines. If seal impression smudges, re-seal if a sufficient area permits, otherwise complete a different acknowledgment form.
  - Signature of the notary public must match the signature on file with the office of the county clerk.
    - ❖ Additional information is not required but could help to ensure this acknowledgment is not misused or attached to a different document.
    - ❖ Indicate title or type of attached document, number of pages and date.
    - ❖ Indicate the capacity claimed by the signer. If the claimed capacity is a corporate officer, indicate the title (i.e. CEO, CFO, Secretary).
  - Securely attach this document to the signed document

# CONTRACTOR CERTIFICATION

---

## DRUG-FREE WORKPLACE

PROJECT TITLE: Boundary St & Edmonton Ave SMR

I hereby certify that I am familiar with the requirements of San Diego City Council Policy No. 100-17 regarding Drug-Free Workplace as outlined in the WHITEBOOK, Section 7-13.3, "Drug-Free Workplace", of the project specifications, and that;

PULLMAN ENGINEERING INC

(Name under which business is conducted)

has in place a drug-free workplace program that complies with said policy. I further certify that each subcontract agreement for this project contains language which indicates the subcontractor's agreement to abide by the provisions of subdivisions a) through c) of the policy as outlined.

Signed

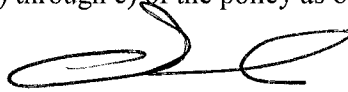

Printed Name

CHRIS PULLMAN

Title

PRES.



# CONTRACTOR CERTIFICATION

---

## AMERICAN WITH DISABILITIES ACT (ADA) COMPLIANCE CERTIFICATION

PROJECT TITLE: Boundary St & Edmonton Ave SMR

I hereby certify that I am familiar with the requirements of San Diego City Council Policy No. 100-4 regarding the American With Disabilities Act (ADA) outlined in the WHITEBOOK, Section 7-13.2, "American With Disabilities Act", of the project specifications, and that;

PULLMAN ENGINEERING INC.

(Name under which business is conducted)

has in place a workplace program that complies with said policy. I further certify that each subcontract agreement for this project contains language which indicates the subcontractor's agreement to abide by the provisions of the policy as outlined.

Signed  \_\_\_\_\_

Printed Name CHRIS PULLMAN \_\_\_\_\_

Title PRES. \_\_\_\_\_

# CONTRACTOR CERTIFICATION

## CONTRACTOR STANDARDS – PLEDGE OF COMPLIANCE

PROJECT TITLE: Boundary St & Edmonton Ave SMR

I declare under penalty of perjury that I am authorized to make this certification on behalf of Pullman Engineering Inc, as Contractor, that I am familiar with the requirements of City of San Diego Municipal Code § 22.3224 regarding Contractor Standards as outlined in the WHITEBOOK, Section 7-13.4, ("Contractor Standards"), of the project specifications, and that Contractor has complied with those requirements.

I further certify that each of the Contractor's subcontractors whose subcontracts are greater than \$50,000 in value has completed a Pledge of Compliance attesting under penalty of perjury of having complied with City of San Diego Municipal Code § 22.3224.

Dated this 8 Day of Dec, 2014.

Signed  \_\_\_\_\_

Printed Name PULLMAN ENGINEERING INC

Title PRES.

**AFFIDAVIT OF DISPOSAL**

**WHEREAS**, on the \_\_\_\_\_ DAY OF \_\_\_\_\_, 2\_\_\_\_\_ the undersigned entered into and executed a contract with the City of San Diego, a municipal corporation, for:

**Boundary St & Edmonton Ave SMR**

(Name of Project)

as particularly described in said contract and identified as Bid No. **K-15-1217-DBB-3**; SAP No. (WBS/IO/CC) **B-13173**; and **WHEREAS**, the specification of said contract requires the Contractor to affirm that "all brush, trash, debris, and surplus materials resulting from this project have been disposed of in a legal manner"; and **WHEREAS**, said contract has been completed and all surplus materials disposed of:

\_\_\_\_\_  
\_\_\_\_\_  
\_\_\_\_\_

**NOW, THEREFORE**, in consideration of the final payment by the City of San Diego to said Contractor under the terms of said contract, the undersigned Contractor, does hereby affirm that all surplus materials as described in said contract have been disposed of at the following location(s)

\_\_\_\_\_  
\_\_\_\_\_  
\_\_\_\_\_

and that they have been disposed of according to all applicable laws and regulations.

Dated this \_\_\_\_\_ DAY OF \_\_\_\_\_, \_\_\_\_\_.

\_\_\_\_\_  
Contractor  
by

**ATTEST:**

State of \_\_\_\_\_  
County of \_\_\_\_\_

On this \_\_\_\_\_ DAY OF \_\_\_\_\_, 2\_\_\_\_\_, before the undersigned, a Notary Public in and for said County and State, duly commissioned and sworn, personally appeared \_\_\_\_\_ known to me to be the \_\_\_\_\_ Contractor named in the foregoing Release, and whose name is subscribed thereto, and acknowledged to me that said Contractor executed the said Release.

Notary Public in and for said County and State

# ATTACHMENTS

**ATTACHMENT A**  
**SCOPE OF WORK**

## SCOPE OF WORK

**1. SCOPE OF WORK:** The project proposes to replace an existing sewer main approximately 1,210 linear feet (LF) of pipe as follows: 342 LF of open cut (8-inch pipe) and rehabilitation of 300 LF (8-inch pipe) within University City High School Parking Lot; installation of approximately 186 LF of 10-inch pipe within 41<sup>st</sup> St; 215 LF of open cut (8-inch pipe) and rehabilitation of approximately 167 LF of pipe within San Miguel St. and in City owned property; The work also includes the abandonment of approximately 709 LF of existing sewer main, and Replumb of approximately 5 sewer laterals.

**1.1.** The Work shall be performed in accordance with:

**1.1.1.** The Notice Inviting Bids and Plans numbered **37679-01-D** through **37679-07-D**, inclusive.

**2. CONSTRUCTION COST:** The City's estimated construction cost for this contract is **\$516,000**.

**3. LOCATION OF WORK:** See the Location Map attached.

**4. CONTRACT TIME:** The Contract Time for completion of the Work shall be **88 Working Days**.

**5. CONTRACTOR'S LICENSE CLASSIFICATION:** In accordance with the provisions of California Law, the Contractor shall possess valid appropriate license(s) at the time that the Bid is submitted. Failure to possess the specified license(s) shall render the Bid as **non-responsive** and shall act as a bar to award of the Contract to any Bidder not possessing required license(s) at the time of Bid.

**5.1.** The City has determined the following licensing classifications for this contract:

Option	Classification(s)
1	CLASS A
2	CLASS C34
3	CLASS C42

**5.2.** The Bidder shall satisfy the licensing requirement by meeting **at least** one of the listed options.

**ATTACHMENT B**  
**INTENTIONALLY LEFT BLANK**

**ATTACHMENT C**  
**EQUAL OPPORTUNITY CONTRACTING PROGRAM**



## **EQUAL OPPORTUNITY CONTRACTING PROGRAM**

1. To The WHITEBOOK, Chapter 10, Sections D and E, DELETE each in its entirety, and SUBSTITUTE with the following:

### **D. CITY'S EQUAL OPPORTUNITY COMMITMENT.**

#### **1. Nondiscrimination in Contracting Ordinance.**

1. The Contractor, Subcontractors and Suppliers shall comply with requirements of the City's Nondiscrimination in Contracting Ordinance, San Diego Municipal Code §§22.3501 through 22.3517.

The Contractor shall not discriminate on the basis of race, gender, religion, national origin, ethnicity, sexual orientation, age, or disability in the solicitation, selection, hiring, or treatment of subcontractors, vendors, or suppliers. The Contractor shall provide equal opportunity for subcontractors to participate in subcontracting opportunities. The Contractor understands and agrees that violation of this clause shall be considered a material breach of the contract and may result in contract termination, debarment, or other sanctions.

The Contractor shall include the foregoing clause in all contracts between the Contractor and Subcontractors and Suppliers.

2. Disclosure of Discrimination Complaints. As part of its Bid or Proposal, the Bidder shall provide to the City a list of all instances within the past 10 years where a complaint was filed or pending against Bidder in a legal or administrative proceeding alleging that Bidder discriminated against its employees, subcontractors, vendors, or suppliers, and a description of the status or resolution of that complaint, including any remedial action taken.
3. Upon the City's request, the Contractor agrees to provide to the City, within 60 days, a truthful and complete list of the names of all Subcontractors and Suppliers that the Contractor has used in the past 5 years on any of its contracts that were undertaken within San Diego County, including the total dollar amount paid by the Contractor for each subcontract or supply contract.
4. The Contractor further agrees to fully cooperate in any investigation conducted by the City pursuant to the City's Nondiscrimination in Contracting Ordinance, Municipal Code §§22.3501 through 22.3517. The Contractor understands and agrees that violation of this clause shall be considered a material breach of the Contract and may result in remedies being ordered against the Contractor up to and including contract termination, debarment and other sanctions for violation of the provisions of the Nondiscrimination in Contracting Ordinance. The Contractor further understands and agrees that the procedures, remedies and sanctions provided for in the Nondiscrimination in Contracting Ordinance apply only to violations of the Ordinance.

**E. EQUAL EMPLOYMENT OPPORTUNITY OUTREACH PROGRAM.**

1. The Contractor, Subcontractors and Suppliers shall comply with the City's Equal Employment Opportunity Outreach Program, San Diego Municipal Code §§22.2701 through 22.2707.

The Contractor shall not discriminate against any employee or applicant for employment on any basis prohibited by law. Contractor shall provide equal opportunity in all employment practices. Prime Contractor shall ensure their subcontractors comply with this program. Nothing in this section shall be interpreted to hold a prime contractor liable for any discriminatory practice of its subcontractors.

The Contractor shall include the foregoing clause in all contracts between the Contractor and Subcontractors and Suppliers.

2. If the Contract is competitively solicited, the selected Bidder shall submit a Work Force Report (Form BB05), within 10 Working Days after receipt by the Bidder of Contract forms to the City for approval as specified in the Notice of Intent to Award letter from the City.
3. If a Work Force Report is submitted, and the City determines there are under-representations when compared to County Labor Force Availability data, the selected Bidder shall submit an Equal Employment Opportunity Plan.
4. If the selected Bidder submits an Equal Employment Opportunity Plan, it shall include the following assurances:
  1. The Contractor shall maintain a working environment free of discrimination, harassment, intimidation and coercion at all sites and in all facilities at which the Contractor's employees are assigned to work.
  2. The Contractor reviews its EEO Policy, at least annually, with all on-site supervisors involved in employment decisions.
  3. The Contractor disseminates and reviews its EEO Policy with all employees at least once a year, posts the policy statement and EEO posters on all company bulletin boards and job sites, and documents every dissemination, review and posting with a written record to identify the time, place, employees present, subject matter, and disposition of meetings.
  4. The Contractor reviews, at least annually, all supervisors' adherence to and performance under the EEO Policy and maintains written documentation of these reviews.
  5. The Contractor discusses its EEO Policy Statement with subcontractors with whom it anticipates doing business, includes the EEO Policy Statement in its subcontracts, and provides such documentation to the City upon request.

6. The Contractor documents and maintains a record of all bid solicitations and outreach efforts to and from subcontractors, contractor associations and other business associations.
7. The Contractor disseminates its EEO Policy externally through various media, including the media of people of color and women, in advertisements to recruit, maintains files documenting these efforts, and provides copies of these advertisements to the City upon request.
8. The Contractor disseminates its EEO Policy to union and community organizations.
9. The Contractor provides immediate written notification to the City when any union referral process has impeded the Contractor's efforts to maintain its EEO Policy.
10. The Contractor maintains a current list of recruitment sources, including those outreaching to people of color and women, and provides written notification of employment opportunities to these recruitment sources with a record of the organizations' responses.
11. The Contractor maintains a current file of names, addresses and phone numbers of each walk-in applicant, including people of color and women, and referrals from unions, recruitment sources, or community organizations with a description of the employment action taken.
12. The Contractor encourages all present employees, including people of color and women employees, to recruit others.
13. The Contractor maintains all employment selection process information with records of all tests and other selection criteria.
14. The Contractor develops and maintains documentation for on-the-job training opportunities, participates in training programs, or both for all of its employees, including people of color and women, and establishes apprenticeship, trainee, and upgrade programs relevant to the Contractor's employment needs.
15. The Contractor conducts, at least annually, an inventory and evaluation of all employees for promotional opportunities and encourages all employees to seek and prepare appropriately for such opportunities.
16. The Contractor ensures the company's working environment and activities are non-segregated except for providing separate or single-user toilets and necessary changing facilities to assure privacy between the sexes.

**ATTACHMENT D**  
**INTENTIONALLY LEFT BLANK**

**ATTACHMENT E**  
**SUPPLEMENTARY SPECIAL PROVISIONS**

## **SUPPLEMENTARY SPECIAL PROVISIONS**

The following Supplementary Special Provisions (SSP) modifies the following documents:

- 1) Standard Specifications for Public Works Construction (The GREENBOOK) currently in effect.
  - 2) The City of San Diego Standard Specifications for Public Works Construction (The WHITEBOOK).
- 

### **SECTION 1 – TERMS, DEFINITIONS, ABBREVIATIONS, UNITS OF MEASURE, AND SYMBOLS**

#### **1-2 TERMS AND DEFINITIONS.**

**Normal Working Hours.** To the City Supplement, ADD the following:

The Normal Working Hours are 8:30 AM to 3:30 PM.

### **SECTION 2 - SCOPE AND CONTROL OF WORK**

#### **2-3.2 Self Performance.** DELETE in its entirety and SUBSTITUTE with the following:

1. You must perform, with your own organization, Contract work amounting to at least 25% of the base bid alone or base bid and any additive or deductive alternate(s) that together when added or deducted form the basis of award.
2. The self performance percentage requirement will be waived for contracts when a “B” License is required or allowed.

#### **2-5.3.1 General.** To the City Supplement, ADD the following

7. For products for which an AML is available, products listed in the AML shall be used. A submittal review will be conducted for products not identified on an AML on a case-by-case basis when:
  - a) The product type or category is not in the AML.
  - b) The AML does not list at least two available manufacturers of the product.
  - c) The material or manufacturer listed in the AML is no longer available. Documentation to substantiate the product is no longer available or in production is required as part of the submittal.

In the case of conducting a submittal review when required by the Plans or Special Provisions, or when requested by the Engineer, all submittals shall be accompanied by the City's submittal form.

The Product Submittal Form is available for download at:

<http://www.sandiego.gov/publicworks/edocref/index.shtml>

**2-11.1.1 General.** To the City Supplement, item 2, ADD the following:

Time lapse video robotic cameras must provide a clear view of backfill and compaction operations. When this is not possible if camera is mounted on excavator, camera must be mounted on a portable tower or similar device and repositioned as Work progresses.

#### **SECTION 4 - CONTROL OF MATERIALS**

**4-1.3.6 Preapproved Materials.** To the City Supplement, ADD the following:

3. You shall submit in writing a list of all products to be incorporated in the Work that are on the AML.

**4-1.6 Trade Names or Equals.** ADD the following:

You must submit your list of proposed substitutions for "an equal" ("or equal") item(s) **no less than 15 Working Days prior to Bid due date** and on the City's Product Submittal Form available at.

<http://www.sandiego.gov/publicworks/edocref/index.shtml>

#### **SECTION 7 - RESPONSIBILITIES OF THE CONTRACTOR**

**7-3 LIABILITY INSURANCE.** DELETE in its entirety and SUBSTITUTE with the following:

The insurance provisions herein must not be construed to limit your indemnity obligations contained in the Contract.

**7-3.1 Policies and Procedures.**

1. You must procure the insurance described below, at its sole cost and expense, to provide coverage against claims for loss including injuries to persons or damage to property, which may arise out of or in connection with the performance of the Work by you, your agents, representatives, officers, employees or Subcontractors.
2. Insurance coverage for property damage resulting from your operations is on a replacement cost valuation. The market value will not be accepted.

3. You must maintain this insurance for the duration of this contract and at all times thereafter when you are correcting, removing, or replacing Work in accordance with this contract. Your liabilities under the Contract, e.g., your indemnity obligations, is not deemed limited to the insurance coverage required by this contract.
4. Payment for insurance is included in the various items of Work as bid by you, and except as specifically agreed to by the City in writing, you are not entitled to any additional payment. Do not begin any work under this contract until you have provided and the City has approved all required insurance.
5. Policies of insurance must provide that the City is entitled to 30 days (10 days for cancellation due to non-payment of premium) prior written notice of cancellation or non-renewal of the policy. Maintenance of specified insurance coverage is a material element of the Contract. Your failure to maintain or renew coverage or to provide evidence of renewal during the term of the Contract may be treated by the City as a material breach of the Contract.

**7-3.2 Types of Insurance.**

**7-3.2.1 Commercial General Liability Insurance.**

1. Commercial General Liability Insurance must be written on the current version of the ISO Occurrence form CG 00 01 07 98 or an equivalent form providing coverage at least as broad.
2. The policy must cover liability arising from premises and operations, XCU (explosions, underground, and collapse), independent contractors, products/completed operations, personal injury and advertising injury, bodily injury, property damage, and liability assumed under an insured’s contract (including the tort liability of another assumed in a business contract).
3. There must be no endorsement or modification limiting the scope of coverage for either “insured vs. insured” claims or contractual liability. You must maintain the same or equivalent insurance for at least 10 years following completion of the Work.
4. All costs of defense must be outside the policy limits. Policy coverage must be in liability limits of not less than the following:

<u>General Annual Aggregate Limit</u>	<u>Limits of Liability</u>
Other than Products/Completed Operations	\$2,000,000
Products/Completed Operations Aggregate Limit	\$2,000,000
Personal Injury Limit	\$1,000,000
Each Occurrence	\$1,000,000

**7-3.2.2 Commercial Automobile Liability Insurance.**

1. You must provide a policy or policies of Commercial Automobile Liability Insurance written on the current version of the ISO form CA 00 01 12 90 or later



version or equivalent form providing coverage at least as broad in the amount of \$1,000,000 combined single limit per accident, covering bodily injury and property damage for owned, non-owned, and hired automobiles (“Any Auto”).

2. All costs of defense must be outside the limits of the policy.

### **7-3.2.3 Contractors Pollution Liability Insurance.**

1. You must procure and maintain at your expense or require Subcontractor, as described below to procure and maintain, the Contractors Pollution Liability Insurance including contractual liability coverage to cover liability arising out of cleanup, removal, storage, or handling of hazardous or toxic chemicals, materials, substances, or any other pollutants by you or any Subcontractor in an amount not less than \$2,000,000 limit for bodily injury and property damage.
2. All costs of defense must be outside the limits of the policy. Any such insurance provided by Subcontractor instead of you must be approved separately in writing by the City.
3. For approval of a substitution of Subcontractor’s insurance, you must certify that all activities for which the Contractors Pollution Liability Insurance will provide coverage will be performed exclusively by the Subcontractor providing the insurance. The deductible must not exceed \$25,000 per claim.
4. Contractual liability must include coverage of tort liability of another party to pay for bodily injury or property damage to a third person or organization. There must be no endorsement or modification of the coverage limiting the scope of coverage for either “insured vs. insured” claims or contractual liability.
5. Occurrence based policies must be procured before the Work commences and must be maintained for the Contract Time. Claims Made policies must be procured before the Work commences, must be maintained for the Contract Time, and must include a 12 month extended Claims Discovery Period applicable to this contract or the existing policy or policies must continue to be maintained for 12 months after the completion of the Work without advancing the retroactive date.
6. Except as provided for under California law, the policy or policies must provide that the City is entitled to 30 days prior written notice (10 days for cancellation due to non-payment of premium) of cancellation or non-renewal of the policy or policies.

**7-3.3 Rating Requirements.** Except for the State Compensation Insurance Fund, all insurance required by this contract as described herein must be carried only by responsible insurance companies with a rating of, or equivalent to, at least “A-, VI” by A.M. Best Company, that are authorized by the California Insurance Commissioner to do business in the State, and that have been approved by the City.

**7-3.3.1 Non-Admitted Carriers.** The City will accept insurance provided by non-admitted, “surplus lines” carriers only if the carrier is authorized to do business in the State and is included on the List of Approved Surplus Lines Insurers (LASLI list).

All policies of insurance carried by non-admitted carriers must be subject to all of the requirements for policies of insurance provided by admitted carriers described herein.

**7-3.4 Evidence of Insurance.** Furnish to the City documents e.g., certificates of insurance and endorsements evidencing the insurance required herein, and furnish renewal documentation prior to expiration of this insurance. Each required document must be signed by the insurer or a person authorized by the insurer to bind coverage on its behalf. We reserve the right to require complete, certified copies of all insurance policies required herein.

**7-3.5 Policy Endorsements.**

**7-3.5.1 Commercial General Liability Insurance.**

**7-3.5.1.1 Additional Insured.**

- a) You must provide at your expense policy endorsement written on the current version of the ISO Occurrence form CG 20 10 11 85 or an equivalent form providing coverage at least as broad.
- b) To the fullest extent allowed by law e.g., California Insurance Code §11580.04, the policy must be endorsed to include the City and its respective elected officials, officers, employees, agents, and representatives as additional insured.
- c) The additional insured coverage for projects for which the Engineer’s Estimate is \$1,000,000 or more must include liability arising out of: (a) Ongoing operations performed by you or on your behalf, (b) your products, (c) your work, e.g., your completed operations performed by you or on your behalf, or (d) premises owned, leased, controlled, or used by you.
- d) The additional insured coverage for projects for which the Engineer’s Estimate is less than \$1,000,000 must include liability arising out of: (a) Ongoing operations performed by you or on your behalf, (b) your products, or (c) premises owned, leased, controlled, or used by you.

**7-3.5.1.2 Primary and Non-Contributory Coverage.** The policy must be endorsed to provide that the coverage with respect to operations, including the completed operations, if appropriate, of the Named Insured is primary to any insurance or self-insurance of the City and its elected officials, officers, employees, agents and representatives. Further, it must provide that any insurance maintained by the City and its elected officials, officers, employees, agents and representatives must be in excess of your insurance and must not contribute to it.

**7-3.5.1.3 Project General Aggregate Limit.** The policy or policies must be endorsed to provide a Designated Construction Project General Aggregate Limit that will apply only to the Work. Only claims payments which arise from the Work must reduce the Designated Construction Project General Aggregate Limit. The Designated

Construction Project General Aggregate Limit must be in addition to the aggregate limit provided for the products-completed operations hazard.

**7-3.5.2 Commercial Automobile Liability Insurance.**

**7-3.5.2.1 Additional Insured.** Unless the policy or policies of Commercial Auto Liability Insurance are written on an ISO form CA 00 01 12 90 or a later version of this form or equivalent form providing coverage at least as broad, the policy must be endorsed to include the City and its respective elected officials, officers, employees, agents, and representatives as additional insured, with respect to liability arising out of automobiles owned, leased, hired or borrowed by you or on your behalf. This endorsement is limited to the obligations permitted by California Insurance Code §11580.04.

**7-3.5.3 Contractors Pollution Liability Insurance Endorsements.**

**7-3.5.3.1 Additional Insured.**

- a) The policy or policies must be endorsed to include as an Insured the City and its respective elected officials, officers, employees, agents, and representatives, with respect to liability arising out of: (a) Ongoing operations performed by you or on your behalf, (b) your products, (c) your work, e.g., your completed operations performed by you or on your behalf, or (d) premises owned, leased, controlled, or used by you; except that in connection with, collateral to, or affecting any construction contract to which the provisions of subdivision (b) of § 2782 of the California Civil Code apply, this endorsement must not provide any duty of indemnity coverage for the active negligence of the City and its respective elected officials, officers, employees, agents, and representatives in any case where an agreement to indemnify the City and its respective elected officials, officers, employees, agents, and representatives would be invalid under subdivision (b) of §2782 of the California Civil Code.
- b) In any case where a claim or loss encompasses the negligence of the Insured and the active negligence of the City and its respective elected officials, officers, employees, agents, and representatives that is not covered because of California Insurance Code §11580.04, the insurer's obligation to the City and its respective elected officials, officers, employees, agents, and representatives must be limited to obligations permitted by California Insurance Code §11580.04.

**7-3.5.3.2 Primary and Non-Contributory Coverage.** The policy or policies must be endorsed to provide that the insurance afforded by the Contractors Pollution Liability Insurance policy or policies is primary to any insurance or self-insurance of the City and its elected officials, officers, employees, agents and representatives with respect to operations including the completed operations of the Named Insured. Any insurance maintained by the City and its elected officials, officers, employees, agents and representatives must be in excess of your insurance and must not contribute to it.

**7-3.5.3.3 Severability of Interest.** For Contractors Pollution Liability Insurance, the policy or policies must provide that your insurance must apply separately to each insured against whom claim is made or suit is brought, except with respect to the limits of the insurer's liability and must provide cross-liability coverage.

**7-3.6 Deductibles and Self-Insured Retentions.** You must pay for all deductibles and self-insured retentions. You must disclose deductibles and self-insured retentions to the City at the time the evidence of insurance is provided.

**7-3.7 Reservation of Rights.** The City reserves the right, from time to time, to review your insurance coverage, limits, deductibles and self-insured retentions to determine if they are acceptable to the City. The City will reimburse you, without overhead, profit, or any other markup, for the cost of additional premium for any coverage requested by the Engineer but not required by this contract.

**7-3.8 Notice of Changes to Insurance.** You must notify the City 30 days prior to any material change to the policies of insurance provided under this contract.

**7-3.9 Excess Insurance.** Policies providing excess coverage must follow the form of the primary policy or policies e.g., all endorsements.

**7-4 WORKERS' COMPENSATION INSURANCE.** DELETE in its entirety and SUBSTITUTE with the following:

**7-4.1 Workers' Compensation Insurance and Employers Liability Insurance.**

1. In accordance with the provisions of §3700 of the California Labor Code, you must provide at your expense Workers' Compensation Insurance and Employers Liability Insurance to protect you against all claims under applicable state workers compensation laws. The City, its elected officials, and employees will not be responsible for any claims in law or equity occasioned by your failure to comply with the requirements of this section.

2. Limits for this insurance must be not less than the following:

<u>Workers' Compensation</u>	<u>Statutory Employers Liability</u>
Bodily Injury by Accident	\$1,000,000 each accident
Bodily Injury by Disease	\$1,000,000 each employee
Bodily Injury by Disease	\$1,000,000 policy limit

3. By signing and returning the Contract you certify that you are aware of the provisions of §3700 of the Labor Code which require every employer to be insured against liability for worker's compensation or to undertake self-insurance in accordance with the provisions of that code and you must comply with such provisions before commencing the Work as required by §1861 of the California Labor Code.

**7-4.1.1 Waiver of Subrogation.** The policy or policies must be endorsed to provide that the insurer will waive all rights of subrogation against the City, and its respective elected officials, officers, employees, agents, and representatives for losses paid under the terms of the policy or policies and which arise from work performed by the Named Insured for the City.

**7-10.5.3 Steel Plate Covers.** Table 7-10.5.3(A), REVISE the plate thickness for 5'-3" trench width to read 1 3/4".

**7-15 INDEMNIFICATION AND HOLD HARMLESS AGREEMENT.** To the City Supplement, fourth paragraph, last sentence, DELETE in its entirety and SUBSTITUTE with the following:

Your duty to indemnify and hold harmless does not include any claims or liability arising from the established active or sole negligence, or willful misconduct of the City, its officers, or employees.

**7-16 COMMUNITY LIASON.** To the City Supplement, DELETE in its entirety and SUSBTITUTE with the following:

**ADD:**

**7-16 COMMUNITY OUTREACH.**

**7-16.1 General.**

1. To ensure consistency with the City’s community outreach plan for the project, the City will work with the Contractor to inform the public (which includes, but is not limited to, property owners, renters, homeowners, business owners, recreational users, and other community members and stakeholders) of construction impacts. Efforts by the Contractor to mitigate construction impacts by communicating with the public require close coordination and cooperation with the City.
2. The Contractor will perform the community outreach activities required throughout the Contract Time.
3. The Contractor shall closely coordinate the Work with the businesses, institutions, residents and property owners impacted by the Project. Example duties of the Contractor include notification to the businesses, institutions and residents of the commencement of construction activities not less than 5 days in advance, coordination of access for vehicular and pedestrian traffic to businesses, institutions and residences impacted by the Project, reporting of Contractor activities at all Project progress meetings scheduled by the Engineer, attendance to the Project Pre-construction Meeting, attendance at 2 community meetings, response to community questions and complaints related to Contractor activities, and written documentation including logging in all inquiries and complaints received into the City’s Public Contact Log located on the City’s SDShare site:  
  
<http://sdshare/forums/ecp/PITS/picr/Lists/Public%20Contact%20Log/AllItems.aspx>
4. The Contractor shall execute the Information Security Policy Acknowledgement Form - For Non-City Employees within 15 days of the award of the Contract if:
  - a) The contact information for the Contractor is made available on any outreach materials or;
  - b) The Contractor will be the primary point of contact to resolve project related inquiries and complaints.

5. **Electronic Communication.**

All inquiries and complaints will be logged in to the City's SDSHare site within 24 hours of receipt of inquiries and complaints.

Any updates or a resolution of inquiries, and complaints shall be documented in the City's SDSHare site within 24 hours.

Copies of email communications shall be saved on to the City's SDSHare site as individually as an Outlook Message Format (\*.msg).

All graphics, photos, and other electronic files associated with the inquiries and or complaints shall be saved into the individual record.

6. **When specified in the Bid**, present your Exclusive Community Liaison to the Engineer, in writing, within 15 days of the award of the Contract.

**7-16.2 Submittals.**

1. The Contractor shall submit to the Resident Engineer, for review and approval, all drafts of letters, notices, postcards, door hangers, signs, mailing lists, proposed addresses for hand-delivery, and any other notices and letters that are to be mailed and or distributed to the public.
  - a. Prior to distributing or mailing, the Contractor shall submit final drafts of letters, notices, postcards, door hangers, signs, and any other notices and letters to the Resident Engineer for final review and approval.
  - b. After distributing or mailing, the Contractor shall submit verification of delivery and any copies of returned notices to the Resident Engineer.
2. The Contractor will use the City's SDSHare site to identify and summarize communications (via phone, in person, and email) with the public the within 24 hours of receipt, even if the Contractor's response to the individual is still incomplete. The Contractor will upload to the City's SDSHare site copies of all written, electronic, and verbal communications and conversations with the public.

**7-16.3 Public Notice by Contractor.**

1. Furnish and distribute public notices in the form of door hangers using the City's format to all occupants and/or property owners along streets where Work is to be performed at least 5 days before starting the Work as directed by the Resident Engineer.
2. For all Work on private property, contact each owner and occupant individually a minimum of 15 days prior to the Work. If the Work has been delayed, re-notify owners and occupants of the new Work schedule, as directed by the Resident Engineer.

**7-16.4 Quality Assurance.**

1. During the course of community outreach, the Contractor shall ensure the character of all persons that conduct community outreach (distributing door hangers, attending community meetings, interacting with the public, etc.), on behalf of the Contractor:
  - a. Have the ability to speak and comprehend English and/or Spanish, as appropriate for the community or public they are informing,
  - b. Possess and display easily verifiable and readable personal identification that identifies the person as an employee of the Contractor,
  - c. Have the interpersonal skills to effectively, professionally, and tactfully represent the project, Contractor, and City to the public.

**7-16.5 Communications with the Public.**

1. The Contractor shall provide updates on construction impacts to the Resident Engineer. The Contractor shall notify the Resident Engineer in advance about time-sensitive construction impacts and may be required to distribute construction impact notices to the public on short notice.
2. The Contractor shall incorporate community outreach activities related to construction impacts in the baseline schedule and update the Resident Engineer with each week's submittal of the Three-Week Look Ahead Schedule.
3. At the request of the Resident Engineer, the Contractor shall attend and participate in project briefings at community meetings.
4. The Contractor shall coordinate with the Resident Engineer on all responses and actions taken to address public inquiries and complaints within 24-hours that they are received.

**7-16.6 Communications with Media.**

1. The City may allow members of the media access to its construction site(s) on a case-by-case basis only.
2. Occasionally, members of the media may show up at construction sites, uninvited. Members of the media (including, but not limited to newspaper, magazine, radio, television, bloggers, and videographers) do not have the legal right to be in the construction site without the City's permission.
3. In the event media representatives arrive near or on the construction site(s), the Contractor shall keep them off the site(s), in a courteous and professional manner, until a Public Information Officer is available to meet them at an approved location.

4. The Contractor shall report all members of the media visits to the Resident Engineer as quickly as possible, so that the City's Public Information Officer can meet with the members of the media at the construction site(s).
5. If the City allows members of the media to access a construction site, the Contractor shall allow the City to escort the media representatives while they are on the construction site and shall ensure their safety.
6. The Contractor shall require media representatives to sign in and out of the Site Visitor Log and to use Personal Protective Equipment.
7. The Contractor has a right to speak to members of the media about its company and its role on the project. All other questions shall be referred to the City.

**7-16.7**

**Exclusive Community Liaison Services.** If directed to conduct Exclusive Community Liaison Services, the Contractor shall retain an Exclusive Community Liaison for the Project whose sole responsibilities will be as follows:

1. Develop a contact list of community, tenants, property owners, and agencies with a stake in the project.
2. Notify businesses, institutions, property owners, and residents of the commencement of construction activities and utility service interruptions not less than 5 days in advance.
3. Coordinate access for vehicular and pedestrian traffic to businesses, institutions and residences impacted by the Project.
4. Prepare and present of materials in coordination with the Resident Engineer (the City's standards and guidelines for the communication materials are available for review by Bidders by sending a request to the Contract Specialist).
5. Respond to community questions and complaints related to Contractor activities.
6. Write, edit, update, or produce brochures, pamphlets and news releases.
7. Provide standard telephone inquiries and e-mail responses:
  - a) Respond to telephone calls and e-mails from the public.
  - b) Record calls and e-mails on the City's SDShare site.
8. Report Exclusive Community Liaison activities at all progress meetings scheduled by the Resident Engineer.
9. Attendance at pre-construction, community and stakeholders meetings.



**7-16.7.1 Exclusive Community Liaison Work Plan.** The Work plan for the Exclusive Community Liaison shall address the items of Work specified in these specifications. Present your Exclusive Community Liaison and submit your exclusive community outreach plan (in writing) as **specified in the Special Provisions** within 15 days of the Award of the Contract.

**7-16.8 Payment.** The Payment for the community outreach and public notices is included in the various Bid items. The payment for exclusive community liaison is in the bid item for “Exclusive Community Liaison Services” when provided as a separate Bid item.” If no Bid item has been provided the payment is included in the various Bid items.

**7-20 ELECTRONIC COMMUNICATION.** ADD the following:

Virtual Project Manager will be used on this contract.

### **SECTION 8 - FACILITIES FOR AGENCY PERSONNEL**

**8-2 FIELD OFFICE FACILITIES.** To the City Supplement, DELETE in its entirety.

### **SECTION 9 - MEASUREMENT AND PAYMENT**

**9-3.2.5 Withholding of Payment.** To the City Supplement, item i), DELETE in its entirety and SUBSTITUTE with the following:

- i) Your failure to comply with 7-2.3, “PAYROLL RECORDS” and 2-16, “CONTRACTOR REGISTRATION AND ELECTRONIC REPORTING SYSTEM.”

**ADD:**

**9-3.7 Compensation Adjustments for Price Index Fluctuations.** This Contract is not subject to the provisions of The WHITEBOOK for Compensation Adjustments for Price Index Fluctuations for the paving asphalt.

### **SECTION 203 – BITUMINOUS MATERIALS**

**203-15 RUBBER POLYMER MODIFIED SLURRY (RPMS).** To the City Supplement, CORRECT section numbering as follows:

<b>OLD SECTION NUMBER</b>	<b>TITLE</b>	<b>NEW SECTION NUMBER</b>
<b>203-15</b>	<b>RUBBER POLYMER MODIFIED SLURRY (RPMS)</b>	<b>203-16</b>
<b>203-15.1</b>	<b>General</b>	<b>203-16.1</b>
<b>203-15.2</b>	<b>Materials</b>	<b>203-16.2</b>

<b>OLD SECTION NUMBER</b>	<b>TITLE</b>	<b>NEW SECTION NUMBER</b>
<b>203-15.3</b>	<b>Composition and Grading</b>	<b>203-16.3</b>
<b>203-15.4</b>	<b>Mix Design</b>	<b>203-16.4</b>

ADD the following:

RPMS shall be used on this contract.

### **SECTION 207 – PIPE**

**207-17.2.3 Pipe Manufacturer.** To the City Supplement, DELETE in its entirety and SUBSTITUTE with the following:

PVC products as manufactured or distributed by J-M Manufacturing Company shall not be used on the Contract for pressurized pipe **unless specified otherwise**.

**207-27 FUSIBLE NON-PRESSURE POLYVINYLCHLORIDE PIPE.** DELETE in its entirety.

### **SECTION 209 – STREET LIGHTING AND TRAFFIC SIGNAL MATERIALS**

**209-6.4 Induction Cobra Head Luminaire.** To the City Supplement, CORRECT certain section numbering as follows:

<b>OLD SECTION NUMBER</b>	<b>TITLE</b>	<b>NEW SECTION NUMBER</b>
<b>209-6.4.7</b>	<b>Luminaire Identification</b>	<b>209-6.4.8</b>
<b>209-6.4.8</b>	<b>Photometric Documentation</b>	<b>209-6.4.9</b>
<b>209-6.4.9</b>	<b>Quality Assurance</b>	<b>209-6.4.10</b>

### **SECTION 300 – EARTHWORK**

**300-1.4 Payment.** To the City Supplement, paragraph (2), DELETE in its entirety and SUBSTITUTE with the following:

2. Payment for existing pavement removal and disposal of up to 12” thick, within the excavation e.g., trench limits, shall be included in the Bid item for installation of the mains or the Work item that requires pavement removal.

### **SECTION 302 – ROADWAY SURFACING**

**302-3 PREPARATORY REPAIR WORK.** To the City Supplement, DELETE in its entirety and SUBSTITUTE with the following:

**PREPARATORY REPAIR WORK.**

1. Prior to roadway resurfacing or the application of slurry, the Contractor shall complete all necessary preparation and repair work to the road segment e.g., tree trimming, weed spray, weed abatement, crack sealing, asphalt repair, hump removal, miscellaneous asphalt patching, removal of raised pavement markers, removal of pavement markings, etc. and as specified in the Special Provisions.
2. Preparatory work shall include, but not be limited to, tree trimming, weed spray, weed abatement, crack sealing, asphalt repair i.e., mill and pave, hump removal, miscellaneous asphalt patching, removal of raised pavement markers, removal of pavement markings, etc.
3. The Contractor shall repair areas of distressed asphalt concrete pavement by milling or removing damaged areas of pavement to a minimum depth of 2” for Residential streets, and a minimum depth of 3” for all others to expose firm and unyielding pavement. The Contractor shall prepare subgrade as needed and install a minimum of 2” for residential streets, and a minimum of 3” for all others, of compacted asphalt concrete pavement over compacted native material as directed by the Engineer.
4. If, in order to achieve the minimum specified depth, the base material is exposed, the material shall be compacted to 95% relative compaction to a depth 10” below the finished grade (dig out). Compaction tests shall be made to ensure compliance with the specifications. The Engineer will determine when and where the test will occur. The City will pay for the soils testing required by the Engineer, which meets the required compaction. The Contractor shall reimburse the City for the cost of retesting failing compaction tests. If additional base material is required, the Contractor shall use Class 2 Aggregate Base in accordance with 200-2.2, “Crushed Aggregate Base.”
5. Recycled base material shall conform to Crushed Miscellaneous Base Material in accordance with 200-2.4, “Crushed Miscellaneous Aggregate Base.”
6. Prior to replacing asphalt, the area shall be cleaned by removing all loose and damaged material, moisture, dirt, and other foreign matter and shall be tack coated in accordance with 302-5.4 “Tack Coat.”
7. The Contractor shall install new asphalt within the repair area or for patches in accordance with 302-5, “ASPHALT CONCRETE PAVEMENT.” Asphalt concrete shall be C2-PG 64-10 in compliance with 400-4, “ASPHALT CONCRETE.”
8. No preparatory asphalt work shall be done when the atmospheric temperature is below 50 °F or during unsuitable weather.
9. Following the asphalt placement, the Contractor shall roll the entire area of new asphalt in both directions at least twice. The finished patch shall be level and smooth in compliance with 302-5.6.2 “Density and Smoothness.” After placement and compaction of the asphalt patch, the Contractor shall seal all finished edges with a 4” wide continuous band of SS-1H.

10. The minimum dimension for each individual repair shall be 4' x 4' and shall be subject to the following conditions:
  - a) If the base material is exposed to achieve the required minimum removal thickness, the base material shall be prepared conforming to 301-1, "SUBGRADE PREPARATION."
  - b) When additional base material is required, then the contractor shall use Class 2 Aggregate Base in accordance with 200-2.2, "Crushed Aggregate Base." Recycled base material shall conform to Crushed Miscellaneous Base Material in accordance with 200-2.4, "Crushed Miscellaneous Aggregate Base."
  - c) The Contractor may use grinding as a method for removal of deteriorated pavement when the areas indicated for removal are large enough (a minimum of the machine drum width) and when approved by the Engineer.
  - d) For both scheduled and unscheduled base repairs, failed areas may be removed by milling or by excavation provided that the edges are cut cleanly with a saw. The areas shall be cleaned and tack coated in accordance with 302-5.4, "Tack Coat" before replacing the asphalt. The areas for scheduled repairs have been marked on the street.

### **302-3.1 Asphalt Patching.**

1. Asphalt patching shall consist of patching potholes, gutter-line erosion, and other low spots in the pavement that are deeper than ½" per 302-5.6.2, "Density and Smoothness." These areas are generally smaller and more isolated than those areas in need of mill and pave.
2. The areas requiring patching have been identified in the Contract Documents, marked on the streets, or as directed by the Engineer. The Contractor shall identify any new areas that may require patching prior to slurry work to ensure the smoothness and quality of the finished product.
3. The Contractor shall identify and repair any areas that may require patching, prior to the placement of slurry seal for smooth finished product.
4. Asphalt overlay shall not be applied over deteriorated pavement. Preparatory asphalt work shall be completed and approved by the Engineer before proceeding with asphalt overlay.
5. The Contractor shall remove distressed asphalt pavement either by saw cutting or milling, to expose firm and unyielding pavement; prepare subgrade (as needed); and install compacted asphalt concrete pavement over compacted native material as directed by the Engineer.
6. Prior to replacing asphalt, the area shall be cleaned and tack coated per 302-5.4, "Tack Coat".

7. Following the asphalt placement, the Contractor shall roll the entire patch in both directions covering the patch at least twice.
8. After placement and compaction of the asphalt patch, the Contractor shall seal all finished edges with a 4" wide continuous band of SS-1H.
9. Base repairs shall not exceed 20% RAP in content.

**302-3.2 Payment.**

1. Payment for replacement of existing pavement when required shall be included in the unit bid price for Asphalt Pavement repair for the total area replaced and no additional payment shall be made regardless of the number of replacements completed. No payment shall be made for areas of over excavation or outside trench areas in utility works unless previously approved by the Engineer. No payment for pavement replacement will be made when the damage is due to the Contractor's failure to protect existing improvements. The Contractor shall reimburse the City for the cost of retesting all failing compaction tests.
2. The areas and quantities shown on the road segments and in appendices are given only for the Contractor's aid in planning the Work and preparing Bids. The Engineer will designate the limits to be removed and these designated areas shall be considered to take precedent over the area shown in an Appendix to the Contract Documents. The quantities shown in the appendices are based on a street assessment survey and may vary.
3. At the end of each day, the Contractor shall submit to the Engineer an itemized list of the asphalt pavement repair work completed. The list shall include the location of the work and the exact square footage of the repair.
4. Preparatory repair work and tack coating will be paid at the Contract unit price per ton for Asphalt Pavement Repair. No payment shall be made for areas of over excavation unless previously approved by the Engineer.
5. Milling shall be included in the Bid item for Asphalt Pavement Repair unless separate Bid item has been provided.
6. Payment for miscellaneous asphalt patching shall be included in the Contract unit price for slurry and no additional payment shall be made therefore.

**302-5.1.1 Damaged AC Pavement Replacement.** To the City Supplement, DELETE in its entirety.

**302-5.1.2 Measurement and Payment.** To the City Supplement, DELETE in its entirety.

**302-5.2.1 Measurement and Payment.** To the City Supplement, item c), ADD the following:

Imported Subgrade material shall be paid per bid item "Imported Backfill".

**SECTION 306 – UNDERGROUND CONDUIT CONSTRUCTION**

**306-1 OPEN TRENCH OPERATIONS.** To the City Supplement, CORRECT certain section numbering as follows:

<b>OLD SECTION NUMBER</b>	<b>TITLE</b>	<b>NEW SECTION NUMBER</b>
<b>306-1.8</b>	<b>House Connection Sewer (Laterals) and Cleanouts</b>	<b>306-1.9</b>
<b>306-1.7.1</b>	<b>Payment</b>	<b>306-1.9.1</b>
<b>306-1.7.2</b>	<b>Sewer Lateral with Private Replumbing</b>	<b>306-1.9.2</b>
<b>306-1.7.2.1</b>	<b>Location</b>	<b>306-1.9.2.1</b>
<b>306-1.7.2.2</b>	<b>Permits</b>	<b>306-1.9.2.2</b>
<b>306-1.7.2.3</b>	<b>Submittals</b>	<b>306-1.9.2.3</b>
<b>306-1.7.2.4</b>	<b>Trenchless Construction</b>	<b>306-1.9.2.4</b>
<b>306-1.7.2.5</b>	<b>Payment</b>	<b>306-1.9.2.5</b>
<b>306-1.7.3.6</b>	<b>Private Pump Installation</b>	<b>306-1.9.2.6</b>
<b>306-1.7.3.7</b>	<b>Payment</b>	<b>306-1.9.2.7</b>

**306-1.6 Basis of Payment for Open Trench Installations.** ADD the following:

Payment for imported backfill when the Contractor elects to import material from a source outside the project limits and when authorized by the Engineer shall be included in the Bid unit price for Imported Backfill. The price shall include the removal and disposal of unsuitable materials.

**306-1.8.3 Polyurethane Lining.** To the City Supplement, item 5, DELETE in its entirety

**306-22 PIPE FUSION.** DELETE in its entirety.

**SECTION 308 – LANDSCAPE AND IRRIGATION INSTALLATION**

**308-7 GUARANTEE.** To the City Supplement, DELETE in its entirety.

**308-7 PAYMENT.** ADD the following:

Work related to tree maintenance shall be included in the Bid items as follows:

- Tree Trimming (EA)
- Root Pruning (EA)
- Root Barrier (EA)

**308-8 PAYMENT.** To the City Supplement, DELETE in its entirety.

## SECTION 500 – PIPELINE

**500-1.1.1 General.** To the City Supplement, (1) (a), ADD the following:

The felt and resin system shall be selected from those listed in the City’s approved material list.

**500-1.1.5 Video Inspection.** To the City Supplement, after the last paragraph, ADD the following:

During the pre-installation video the contractor must identify all existing protruding laterals with the existing main and trim them flush to the main prior to rehabilitation. The cost of trimming the existing laterals will be included in the pipe rehabilitation bid item.

**500-1.1.9 Measurement and Payment.** Third Paragraph, DELETE in its entirety.

**500-1.2.4 Sewer Bypassing and Dewatering.** DELETE in its entirety and SUBSTITUTE with the following:

When required by the Contract Documents, the Contractor shall bypass the sewer flow around the Work and dewater the Site in conformance with 704, “SEWAGE SPILL PREVENTION” and 705-2.1, “General.”

**500-1.6 Service Laterals.** To the City Supplement, DELETE in its entirety and SUBSTITUTE with the following:

**ADD:**

**500-1.6 Service Lateral Rehabilitation.**

**500-1.6.1 General.**

- a) The rehabilitation shall be accomplished using a fabric or fiberglass tube of particular length and a thermoset resin with physical and chemical properties appropriate for the application without excavation and disturbing surface improvements. The tube is vacuum impregnated with the resin. Access to an upstream end of the service lateral is made by excavation in the public right of way. Installation of the resin-impregnated tube into the service lateral may be performed either by Type A inversion in accordance with ASTM F1216 or by Type B pull-in in accordance with ASTM F 1743, and may be performed from either the mainline or the excavated end of the lateral.
- b) The cured-in-place liner shall extend the entire length of the lateral from the access point to the mainline. The liner shall be extended sufficiently to create a water tight seal at the main and the liner interface. Once the tube or resin composite is cured, the installation equipment shall be removed and the protruding end in the collector shall be cut using a robotic cutting device. A sewer cleanout in accordance with the Standard Drawing SDS-102 “Sewer Lateral Cleanout (In Driveway, Paved Alley, Sidewalk, or Other Area Subject

to Traffic)”or SDS-103 “Sewer Lateral Cleanout Outside Traveled Way” shall be installed at the access point and properly backfilled.

A lateral rehabilitation including the installation of lateral cleanout and backfill process should be completed within 15 Working Days.

- c) The liner shall be extended sufficiently to create a water tight seal at the main and the liner interface.
- d) If there is a SLC in place, then the cured-in-place lateral liner shall have a minimum overlap of 2” over the previously installed SLC sewer main lateral connection.

**500-1.6.2 Material.**

- a) The tube shall consist of one or more layers of flexible needled felt, or an equivalent material. Where the tube is fabricated from non woven felt, the longitudinal and circumferential joints are made up by seal bonding. The tube shall be capable of conforming to bends, off-set joints, bells, and disfigured pipe sections. The resin and catalyst system as designed for the specific application shall meet the chemical resistance requirements of 210-2.3.3, “Chemical Resistance Test (Pickle Jar Test).”
- b) The composite of the materials above shall, upon installation inside the host pipe, shall exceed the minimum test standards specified in Table 500-1.4.2 (A).

**500-1.6.3 Installation Procedures (ASTM F1216-98 and ASTM F1743).**

- a) The Property Owner of the lateral being reconstructed shall be informed, and the flow stopped, for the period of reconstruction work.
- b) The Contractor shall excavate an access pit at the appropriate upstream point on the service lateral in accordance with the reconstruction length determined by the Engineer.
- c) The Contractor shall always clean and color video the lateral line immediately prior to reconstruction and determine the structural condition of the pipeline. Roots, debris, and protruding service connections shall be removed prior to reconstruction.
- d) The tube shall be inspected for torn or frayed sections. The tube in good condition shall then be vacuum impregnated with the thermoset resin.
- e) No open pans or uncontrolled open-air pouring of resin shall be allowed during tube saturation. Resin shall be contained within the inflation bladder during vacuum impregnation and insertion. The Contractor shall ensure that no public property is exposed to contamination by liquid resin compounds or components.
- f) The saturated tube along with the inflation bladder shall be inserted into the installation equipment and the end closed. The entire installation equipment shall be placed in the pipe access pit and aligned with the exposed end of the pipe.



- g) The resin and tube shall be completely protected during the placement. The resin shall not be contaminated or diluted by exposure to dirt, debris, or water during the placement.
- h) The tube shall be installed from the installation equipment by controlled air, water or steam pressure as in accordance with manufacturer instructions. The installation shall be stopped when the tube extends the entire length of the lateral section to be lined. The tube is held tightly in place against the wall of the host pipe by the pressure until the cure is complete.
- i) When the curing process is complete, the pressure is released and the inflation bladder reverted back into the installation equipment and removed from the pit.
- j) No barriers, coatings, or any material other than the cured tube or resin composite specifically designed for desirable physical and chemical resistance properties shall be left in the host pipe. Any materials used in the installation other than the cured tube or resin composite shall be removed.
- k) Any cured tube or resin composite pipe left protruding from the service connection shall be trimmed back using a hydraulic-powered robotic cutting device specifically designed for cutting cured-in-place pipe made from these materials.
- l) A second color video inspection shall be performed to verify the proper cure of the material, the proper trim of service connection, and the integrity of the seamless pipe.
- m) The bypass pumping system shall be removed and the sewer flows restored to normal flow conditions. The service lateral pipes shall be coupled together. The excavation shall be properly backfilled. The property owner of the service connection shall be informed when the Work is complete.

**500-1.6.4**     **Deviations.** If pre-installation inspection reveals conditions in the service lateral to be substantially different than those used in the design of wall thickness, tube construction, tube length, or resin system; then the Contractor shall correct the situation as approved by the Engineer.

**500-1.6.5**     **Acceptance.** Upon completion, the Contractor shall deliver the video records and written reports to the Engineer. The Engineer shall review the documentation and the Site to determine if the Work is complete and the work may be accepted.

**500-1.6.6**     **Payment.**

- a) Payment for the Work covered under 500-1.6, “Service Laterals Rehabilitation” shall be made per each lateral.
- b) The payment for the installation of a sewer cleanout at the access point and televising of the service laterals shall be included in the payment for lateral rehabilitation.

- c) Payment for in-situ point repairs shall be included in the bid price for in-situ point repairs and paid for in accordance with 500-1.1.9, “Measurement and Payment” and 500-1.2.7, “Payment.”

**500-1.7.10 Payment.** To the City Supplement, DELETE in its entirety.

**500-1.10.7 Payment.** To the City Supplement, DELETE in its entirety.

**500-1.13.10 Payment.** To the City Supplement, DELETE in its entirety.

**500-4 SERVICE LATERAL CONNECTION SEALING.** DELETE in its entirety and SUBSTITUTE with the following:

**500-4 SERVICE LATERAL CONNECTION (SLC) SEALING.**

**500-4.1 General.**

1. SLC is the interface of the house sewer lateral with the main sewer. SLC to rehabilitated sanitary sewer lines shall be sealed, normally without excavation, by the installation of a resin-impregnated, flexible, felt tube or fiberglass tube installed into the existing service lateral. The tube shall form a “tee” section with a full lap inside the main pipe and shall extend continuously from the sewer main into the lateral for a minimum of 4”. SLC may be a combination of “tees” or “wyes” of varying angle. The resin shall be cured to form the tube into a hard impermeable pipe-within-a-pipe. When cured, the SLC shall seal the connection of the lateral to the mainline in a continuous tight-fitting, watertight pipe-within-a-pipe to eliminate any visible leakage between the lateral and mainline and shall provide a leak-proof seal designed for a minimum 50-year life to prevent root intrusion, infiltration, and exfiltration between a liner and a host pipe.
2. Prior to cleaning and pre-rehab video inspection, the Contractor shall submit a detailed operational plan for the proposed cleaning of all roots inside the pipe and around the service connection for the Engineer’s approval. After cleaning, the Contractor shall proceed with lining of the pipe and reinstating all live service connections. The service connection openings shall conform to the shape and the size of the inside diameter of the existing service connection. Contractor shall use a wire brush or other methods and equipment as recommended by other lining system providers, or other approved means and methods to provide a smooth opening for connecting the lateral to the newly lined pipeline.
3. The Contractor shall trim all protruding laterals which interfere with the lining installation, as flush with the pipe interior as practicable.

**500-4.2 Reference Specification.** This specification references ASTM test methods which are made a part hereof by such reference and shall be the latest edition and revision thereof and shall meet the chemical resistance requirements of section 210-2.3.3, “Chemical Resistance Test (Pickle Jar Test).”

**500-4.3 General Corrosion Requirements.**

- a) The finished SLC product shall be fabricated from materials which when cured shall be chemically resistant to withstand internal exposure to domestic sewage and shall meet the chemical resistance requirements of 210-2.3.3, “Chemical Resistance Test (Pickle Jar Test)” and Table 210-2.4.1 (A).
- b) The SLC product shall be compatible with the lining system materials utilized in the main sewer line.

**500-4.4 SLC Materials.**

- a) A flexible, felt tube shall be fabricated to neatly fit the internal circumference of the conduit specified by the City. Allowance shall be made for circumferential stretching during insertion.
- b) The SLC connection shall extend minimum 4” from the mainline into the lateral.
- c) The Contractor shall furnish a specially designed, unsaturated polyester or vinyl ester resin, and catalyst system compatible with the SLC process that provides cured physical strengths specified herein.

**500-4.5 Physical Properties.**

- a) The cured SLC shall conform to the minimum structural standards as listed in Table 500-1.4.2 (A).
- b) No cured-in-place pipe rehabilitation technology shall be allowed that requires bonding to the existing pipe for any part of its structural strength.
- c) Design methods are to be derived for various loading parameters and modes of failure. Equations shall be modified to include deformation in the shape of an oval as a design parameter. The design method shall be submitted to the Engineer for approval prior to the Pre-construction Meeting.

**500-4.6 Installation Preparation.**

- a) The Contractor shall remove internal debris out of the sewer line.
- b) Inspection of pipelines shall be performed by experienced personnel trained in locating breaks and obstacles by closed circuit television. The interior of the pipeline shall be carefully inspected to determine the location of any conditions which may prevent proper installation of the SLC into the pipelines, and it shall be noted so that these conditions can be corrected. A color video and suitable log shall be kept for later reference by the City.
- c) The Contractor, when required, shall provide for the flow of sewage around the section or sections of mainline pipe where the service lateral designated for SLC is located. The bypass shall be made by plugging the line at an existing upstream manhole and pumping the flow into a downstream manhole or

adjacent system. The pump and bypass lines shall be of adequate capacity and size to handle the flow without service interruption. The bypass systems shall be approved in advance by the City.

- d) The service lateral shall be inactive during the time of installation.
- e) The Contractor shall clear the line of obstructions that prevent the insertion of the SLC material. If inspection reveals an obstruction that cannot be removed by conventional sewer cleaning equipment, the Contractor shall make an external point repair excavation to uncover and remove the obstruction. The Contractor shall inform the Engineer prior to the commencement of the Work.
- f) The mainline pipe opening shall be prepared to accept the SLC and the mainline rehabilitated pipe shall be maximized to obtain the best possible connection.
- g) The transition from the mainline pipe to the service lateral shall be smooth and continuous to provide adequate support for the SLC during installation and cure.

**500-4.7 SLC Installation.**

- a) The resin impregnated tube shall be loaded inside a pressure apparatus. The pressure apparatus, attached to a robotic device, shall be positioned in the mainline pipe at the service connection. The robotic device, together with a television camera, shall be used to align the SLC repair with the service connection opening. Air pressure, supplied to the pressure apparatus through an air hose, shall be used to invert the resin impregnated SLC into the lateral pipe. The inversion pressure shall be adjusted to fully invert the SLC into the lateral pipe and hold the tube tight to the pipe wall. Care shall be taken during the curing process not to over-stress the tube.
- b) The pressure apparatus shall include a bladder which shall inflate in the mainline pipe, effectively seating the SLC repair against the service connection.
- c) After inversion or pull in is completed, recommended pressure is maintained on the impregnated tube for the duration of the curing process. Curing method shall be compatible with the resin selected. An ultraviolet (UV) light cured, heat cured or ambient cured resin system is typically used.
- d) The initial cure shall be deemed to be completed when the SLC has been exposed to the UV light, heat source or held in place for the time period specified by the manufacturer.
- e) The Contractor shall cool the hardened SLC before relieving the pressure in the pressure apparatus. Cool-down may be accomplished by the introduction of cool air into the pressure apparatus. Care shall be taken to maintain proper pressure throughout the cure and cool-down period.
- f) The finished SLC shall be free of dry spots, lifts and delamination. The lateral SLC shall not inhibit the closed circuit television post video inspection of the mainline or service lateral pipes. Frayed ends of the SLC repair shall be removed prior to acceptance.

- g) During the warranty period, any defects which shall affect the integrity of strength of the SLC shall be repaired at the Contractor's expense in a manner mutually agreed upon by the manufacturer, City, and the Contractor.
- h) After the Work is completed, the Contractor shall provide the City with a video disc showing the completed work including the restored conditions.

**500-4.8 Clean-Up.** Upon acceptance of the installation work, the Contractor shall reinstate the Site affected by its operations.

**500-4.9 Payment:** Payment for SLC sealing systems shall be made at the Contract Unit Price or lump sum price in the Bid for each SLC. The Contract Unit Price or lump sum price in the Bid shall include the installation of the SLC sealing system, surface preparation and repairs, preparation and tape submittal of all pre- and post-construction CCTV inspection, bypassing if required, and testing, unless otherwise specified in the Special Provisions.

### **SECTION 703 – ENCOUNTERING OR RELEASING HAZARDOUS SUBSTANCES**

**703-20 PAYMENT.** To the City Supplement, Item 1, DELETE in its entirety and SUBSTITUTE with the following:

1. Payment for waste management shall be included in the applicable Bid items as follows:
  - a) Preparation of Hazardous Waste Management Plan and Reporting (LS).
  - b) Monitoring, Testing, Sampling, Site Storage, and Handling of Soils Containing RCRA Hazardous Waste (TON).
  - c) Loading, Transportation, and Disposal of soils containing RCRA Hazardous Waste (TON).
  - d) Monitoring of Petroleum Contaminated Soil (HR).
  - e) Testing, Sampling, Site Storage and Handling of Petroleum Contaminated Soil (TON).
  - f) Loading, Transportation, and Disposal of Petroleum Contaminated Soil (TON).
  - g) Monitoring, Testing, Sampling Site Storage and Handling of Soils Containing Non-RCRA Hazardous Waste (TON).
  - h) Loading, Transportation, and Disposal of Soils Containing Non-RCRA Hazardous Waste (TON).
  - i) Testing, Sampling, Site Storage, Handling, Transportation, and Disposal of Containerized RCRA Hazardous Waste (55 Gal DRUMS).

- j) Testing, Sampling, Site Storage, Handling, Transportation, and Disposal of Containerized Non-RCRA Hazardous Waste (55 Gal DRUMS).
- k) Testing, Sampling, Site Storage, Handling, Transportation and Recycling/Disposal of Universal Waste (EACH).
- l) Testing, Sampling, Site Storage, Handling, Transportation and Recycling/Disposal of Regulated Waste (TON).
- m) Testing, Sampling, Site Storage, Handling, Transportation, and Disposal of RCRA Hazardous Waste contamination from the treatment of contaminated ground water (GAL).
- n) Testing, Sampling, Site Storage, Handling, Transportation, and Disposal of Non-RCRA Hazardous Waste contamination from the treatment of contaminated ground water (GAL).

**SECTION 705 – WATER DISCHARGES**

- 705-2.6.1**      **General. Paragraph (3), CORRECT reference to Section 803 to read “Section 703.”**
- 705-2.6.3**      **Community Health and Safety Plan.** To the City Supplement, DELETE in its entirety and SUBSTITUTE with the following:
- 705-2.6.3**      **Community Health and Safety Plan.** See 703-2, “Community Health and Safety Plan.”

**END OF SUPPLEMENTARY SPECIAL PROVISIONS (SSP)**

**SUPPLEMENTARY SPECIAL PROVISIONS**

**APPENDICES**

**APPENDIX A**  
**NOTICE OF EXEMPTION**



**NOTICE OF EXEMPTION**

*(Check one or both)*

TO:  X  RECORDER/COUNTY CLERK  
P.O. BOX 1750, MS A-33  
1600 PACIFIC HWY, ROOM 260  
SAN DIEGO, CA 92101-2422

FROM: CITY OF SAN DIEGO  
DEVELOPMENT SERVICES DEPARTMENT  
1222 FIRST AVENUE, MS 501  
SAN DIEGO, CA 92101

           OFFICE OF PLANNING AND RESEARCH  
1400 TENTH STREET, ROOM 121  
SACRAMENTO, CA 95814

PROJECT NO.: B-13173.02.06

PROJECT TITLE: Boundary Street and Edmonton Avenue SMR

PROJECT LOCATION-SPECIFIC: The Edmonton Avenue site is located on San Diego Unified School District property within the paved parking lot of University City High School, in the University community planning area (Council District 1). The Boundary Avenue site is located within portions of the developed right-of-way on 41<sup>st</sup> Street and San Miguel Avenue within the Southeastern community planning area (Council District 9).

PROJECT LOCATION-CITY/COUNTY: San Diego/San Diego

DESCRIPTION OF NATURE AND PURPOSE OF THE PROJECT: At the Edmonton Avenue site, this project will include: 1) the rehabilitation of approximately 300 linear feet (LF) of existing 8-inch sewer main and one manhole using trenchless technology; and 2) the replacement of approximately 342 LF of 8-inch sewer main within the same trench at the same depth of the existing pipe. At the Boundary Street site, the project will include: 1) the installation of approximately 240 LF of new 10-inch sewer main and one new manhole on 41<sup>st</sup> Street at a maximum depth of 19 feet and four sewer lateral replumbs; 2) the rehabilitation of approximately 167 LF of existing 10-inch sewer main, two manholes, and two sewer lateral connections using trenchless technology along San Miguel Avenue; 3) the abandonment of approximately 598 LF of sewer main traversing both private and City-owned property between San Miguel Avenue and 41<sup>st</sup> Street; 4) the installation of a new sewer main approximately 215 LF in length extending west from the San Miguel Avenue cul-de-sac; and 5) associated improvements, including the installation of three new manholes, two new sewer lateral replumbs, and a sewer lateral connection. The new sewer main and associated improvements would be located entirely on City-owned land and within a new easement.

NAME OF PUBLIC AGENCY APPROVING PROJECT: City of San Diego

NAME OF PERSON OR AGENCY CARRYING OUT PROJECT: City of San Diego, Public Works Contact: Jericho Gallardo  
525 B Street, Suite 750 (MS 908A) San Diego, CA 92101 (619) 533-7523

EXEMPT STATUS: (CHECK ONE)

- MINISTERIAL (SEC. 21080(b)(1); 15268);
- DECLARED EMERGENCY (SEC. 21080(b)(3); 15269(a));
- EMERGENCY PROJECT (SEC. 21080(b)(4); 15269 (b)(c))
- CATEGORICAL EXEMPTION:
- STATUTORY EXEMPTION: SEC 15282(k)—Pipelines less than one mile

REASONS WHY PROJECT IS EXEMPT: The City of San Diego conducted an environmental review and determined the project meets the statutory exemption criteria set forth in the CEQA State Guidelines, Section 15282(k) [Other Statutory Exemptions—Pipelines less than one mile], which allows for the installation of new pipeline or maintenance, repair, restoration, removal, or demolition of an existing pipeline as set forth in Section 21080 of the Public Resources Code, as long as the project does not exceed one mile in length. The project’s work does not exceed one mile in length, would be located entirely on City-owned land, and will have no impact to sensitive resources.

LEAD AGENCY CONTACT PERSON: REBECCA MALONE

TELEPHONE: (619) 446-5371

IF FILED BY APPLICANT:

1. ATTACH CERTIFIED DOCUMENT OF EXEMPTION FINDING.
2. HAS A NOTICE OF EXEMPTION BEEN FILED BY THE PUBLIC AGENCY APPROVING THE PROJECT?  
 YES       NO

IT IS HEREBY CERTIFIED THAT THE CITY OF SAN DIEGO HAS DETERMINED THE ABOVE ACTIVITY TO BE EXEMPT FROM CEQA

*Meghan A. ...*

January 7, 2014

SIGNATURE/TITLE

DATE

CHECK ONE:

- SIGNED BY LEAD AGENCY
- SIGNED BY APPLICANT

DATE RECEIVED FOR FILING WITH COUNTY CLERK OR OPR:

**APPENDIX B**  
**FIRE HYDRANT METER PROGRAM**

<b>CITY OF SAN DIEGO CALIFORNIA DEPARTMENT INSTRUCTIONS</b>	<b>NUMBER DI 55.27</b>	<b>DEPARTMENT Water Department</b>
<b>SUBJECT  FIRE HYDRANT METER PROGRAM (FORMERLY: CONSTRUCTION METER PROGRAM)</b>	<b>PAGE 1 OF 10</b>	<b>EFFECTIVE DATE  October 15, 2002</b>
	<b>SUPERSEDES DI 55.27</b>	<b>DATED April 21, 2000</b>

1. **PURPOSE**

1.1 To establish a Departmental policy and procedure for issuance, proper usage and charges for fire hydrant meters.

2. **AUTHORITY**

2.1 All authorities and references shall be current versions and revisions.

2.2 San Diego Municipal Code (NC) Chapter VI, Article 7, Sections 67.14 and 67.15

2.3 Code of Federal Regulations, Safe Drinking Water Act of 1986

2.4 California Code of Regulations, Titles 17 and 22

2.5 California State Penal Code, Section 498B.0

2.6 State of California Water Code, Section 110, 500-6, and 520-23

2.7 Water Department Director

**Reference**

2.8 State of California Guidance Manual for Cross Connection Programs

2.9 American Water Works Association Manual M-14, Recommended Practice for Backflow Prevention

2.10 American Water Works Association Standards for Water Meters

2.11 U.S.C. Foundation for Cross Connection Control and Hydraulic Research Manual

3. **DEFINITIONS**

3.1 **Fire Hydrant Meter:** A portable water meter which is connected to a fire hydrant for the purpose of temporary use. (These meters are sometimes referred to as Construction Meters.)

<b>CITY OF SAN DIEGO CALIFORNIA DEPARTMENT INSTRUCTIONS</b>	<b>NUMBER DI 55.27</b>	<b>DEPARTMENT Water Department</b>
<b>SUBJECT  FIRE HYDRANT METER PROGRAM (FORMERLY: CONSTRUCTION METER PROGRAM)</b>	<b>PAGE 2 OF 10</b>	<b>EFFECTIVE DATE  October 15, 2002</b>
	<b>SUPERSEDES DI 55.27</b>	<b>DATED April 21, 2000</b>

- 3.2 **Temporary Water Use:** Water provided to the customer for no longer than twelve (12) months.
- 3.3 **Backflow Preventor:** A Reduced Pressure Principal Assembly connected to the outlet side of a Fire Hydrant Meter.

4. **POLICY**

- 4.1 The Water Department shall collect a deposit from every customer requiring a fire hydrant meter and appurtenances prior to providing the meter and appurtenances (see Section 7.1 regarding the Fees and Deposit Schedule). The deposit is refundable upon the termination of use and return of equipment and appurtenances in good working condition.
- 4.2 Fire hydrant meters will have a 2 ½" swivel connection between the meter and fire hydrant. The meter shall not be connected to the 4" port on the hydrant. All Fire Hydrant Meters issued shall have a Reduced Pressure Principle Assembly (RP) as part of the installation. Spanner wrenches are the only tool allowed to turn on water at the fire hydrant.
- 4.3 The use of private hydrant meters on City hydrants is prohibited, with exceptions as noted below. All private fire hydrant meters are to be phased out of the City of San Diego. All customers who wish to continue to use their own fire hydrant meters must adhere to the following conditions:
  - a. Meters shall meet all City specifications and American Water Works Association (AWWA) standards.
  - b. Customers currently using private fire hydrant meters in the City of San Diego water system will be allowed to continue using the meter under the following conditions:
    - 1. The customer must submit a current certificate of accuracy and calibration results for private meters and private backflows annually to the City of San Diego, Water Department, Meter Shop.

<b>CITY OF SAN DIEGO CALIFORNIA DEPARTMENT INSTRUCTIONS</b>	<b>NUMBER DI 55.27</b>	<b>DEPARTMENT Water Department</b>
<b>SUBJECT  FIRE HYDRANT METER PROGRAM (FORMERLY: CONSTRUCTION METER PROGRAM)</b>	<b>PAGE 3 OF 10</b>	<b>EFFECTIVE DATE  October 15, 2002</b>
	<b>SUPERSEDES DI 55.27</b>	<b>DATED April 21, 2000</b>

2. The meter must be properly identifiable with a clearly labeled serial number on the body of the fire hydrant meter. The serial number shall be plainly stamped on the register lid and the main casing. Serial numbers shall be visible from the top of the meter casing and the numbers shall be stamped on the top of the inlet casing flange.
3. All meters shall be locked to the fire hydrant by the Water Department, Meter Section (see Section 4.7).
4. All meters shall be read by the Water Department, Meter Section (see Section 4.7).
5. All meters shall be relocated by the Water Department, Meter Section (see Section 4.7).
6. These meters shall be tested on the anniversary of the original test date and proof of testing will be submitted to the Water Department, Meter Shop, on a yearly basis. If not tested, the meter will not be allowed for use in the City of San Diego.
7. All private fire hydrant meters shall have backflow devices attached when installed.
8. The customer must maintain and repair their own private meters and private backflows.
9. The customer must provide current test and calibration results to the Water Department, Meter Shop after any repairs.
10. When private meters are damaged beyond repair, these private meters will be replaced by City owned fire hydrant meters.

<b>CITY OF SAN DIEGO CALIFORNIA DEPARTMENT INSTRUCTIONS</b>	<b>NUMBER DI 55.27</b>	<b>DEPARTMENT Water Department</b>
<b>SUBJECT  FIRE HYDRANT METER PROGRAM (FORMERLY: CONSTRUCTION METER PROGRAM)</b>	<b>PAGE 4 OF 10</b>	<b>EFFECTIVE DATE  October 15, 2002</b>
	<b>SUPERSEDES DI 55.27</b>	<b>DATED April 21, 2000</b>

11. When a private meter malfunctions, the customer will be notified and the meter will be removed by the City and returned to the customer for repairs. Testing and calibration results shall be given to the City prior to any re-installation.
  12. The register shall be hermetically sealed straight reading and shall be readable from the inlet side. Registration shall be in hundred cubic feet.
  13. The outlet shall have a 2 ½ “National Standards Tested (NST) fire hydrant male coupling.
  14. Private fire hydrant meters shall not be transferable from one contracting company to another (i.e. if a company goes out of business or is bought out by another company).
- 4.4 All fire hydrant meters and appurtenances shall be installed, relocated and removed by the City of San Diego, Water Department. All City owned fire hydrant meters and appurtenances shall be maintained by the City of San Diego, Water Department, Meter Services.
- 4.5 If any fire hydrant meter is used in violation of this Department Instruction, the violation will be reported to the Code Compliance Section for investigation and appropriate action. Any customer using a fire hydrant meter in violation of the requirements set forth above is subject to fines or penalties pursuant to the Municipal Code, Section 67.15 and Section 67.37.
- 4.6 **Conditions and Processes for Issuance of a Fire Hydrant Meter**
- Process for Issuance
- a. Fire hydrant meters shall only be used for the following purposes:
    1. Temporary irrigation purposes not to exceed one year.

<b>CITY OF SAN DIEGO CALIFORNIA DEPARTMENT INSTRUCTIONS</b>	<b>NUMBER DI 55.27</b>	<b>DEPARTMENT Water Department</b>
<b>SUBJECT  FIRE HYDRANT METER PROGRAM (FORMERLY: CONSTRUCTION METER PROGRAM)</b>	<b>PAGE 5 OF 10</b>	<b>EFFECTIVE DATE  October 15, 2002</b>
	<b>SUPERSEDES DI 55.27</b>	<b>DATED April 21, 2000</b>

2. Construction and maintenance related activities (see Tab 2).
  - b. No customer inside or outside the boundaries of the City of San Diego Water Department shall resell any portion of the water delivered through a fire hydrant by the City of San Diego Water Department.
  - c. The City of San Diego allows for the issuance of a temporary fire hydrant meter for a period not to exceed 12 months (365 days). An extension can only be granted in writing from the Water Department Director for up to 90 additional days. A written request for an extension by the consumer must be submitted at least 30 days prior to the 12 month period ending. No extension shall be granted to any customer with a delinquent account with the Water Department. No further extensions shall be granted.
  - d. Any customer requesting the issuance of a fire hydrant meter shall file an application with the Meter Section. The customer must complete a "Fire Hydrant Meter Application" (Tab 1) which includes the name of the company, the party responsible for payment, Social Security number and/or California ID, requested location of the meter (a detailed map signifying an exact location), local contact person, local phone number, a contractor's license (or a business license), description of specific water use, duration of use at the site and full name and address of the person responsible for payment.
  - e. At the time of the application the customer will pay their fees according to the schedule set forth in the Rate Book of Fees and Charges, located in the City Clerk's Office. All fees must be paid by check, money order or cashiers check, made payable to the City Treasurer. Cash will not be accepted.
  - f. No fire hydrant meters shall be furnished or relocated for any customer with a delinquent account with the Water Department.
  - g. After the fees have been paid and an account has been created, the



<b>CITY OF SAN DIEGO CALIFORNIA DEPARTMENT INSTRUCTIONS</b>	<b>NUMBER DI 55.27</b>	<b>DEPARTMENT Water Department</b>
<b>SUBJECT  FIRE HYDRANT METER PROGRAM (FORMERLY: CONSTRUCTION METER PROGRAM)</b>	<b>PAGE 6 OF 10</b>	<b>EFFECTIVE DATE  October 15, 2002</b>
	<b>SUPERSEDES DI 55.27</b>	<b>DATED April 21, 2000</b>

meter shall be installed within 48 hours (by the second business day). For an additional fee, at overtime rates, meters can be installed within 24 hours (within one business day).

#### 4.7 Relocation of Existing Fire Hydrant Meters

- a. The customer shall call the Fire Hydrant Meter Hotline (herein referred to as “Hotline”), a minimum of 24 hours in advance, to request the relocation of a meter. A fee will be charged to the existing account, which must be current before a work order is generated for the meter’s relocation.
- b. The customer will supply in writing the address where the meter is to be relocated (map page, cross street, etc). The customer must update the original Fire Hydrant Meter Application with any changes as it applies to the new location.
- c. Fire hydrant meters shall be read on a monthly basis. While fire hydrant meters and backflow devices are in service, commodity, base fee and damage charges, if applicable, will be billed to the customer on a monthly basis. If the account becomes delinquent, the meter will be removed.

#### 4.8 Disconnection of Fire Hydrant Meter

- a. After ten (10) months a “Notice of Discontinuation of Service” (Tab 3) will be issued to the site and the address of record to notify the customer of the date of discontinuance of service. An extension can only be granted in writing from the Water Department Director for up to 90 additional days (as stated in Section 4.6C) and a copy of the extension shall be forwarded to the Meter Shop Supervisor. If an extension has not been approved, the meter will be removed after twelve (12) months of use.
- b. Upon completion of the project the customer will notify the Meter Services office via the Hotline to request the removal of the fire hydrant meter and appurtenances. A work order will be generated

<b>CITY OF SAN DIEGO CALIFORNIA DEPARTMENT INSTRUCTIONS</b>	<b>NUMBER DI 55.27</b>	<b>DEPARTMENT Water Department</b>
<b>SUBJECT  FIRE HYDRANT METER PROGRAM (FORMERLY: CONSTRUCTION METER PROGRAM)</b>	<b>PAGE 7 OF 10</b>	<b>EFFECTIVE DATE  October 15, 2002</b>
	<b>SUPERSEDES DI 55.27</b>	<b>DATED April 21, 2000</b>

for removal of the meter.

- c. Meter Section staff will remove the meter and backflow prevention assembly and return it to the Meter Shop. Once returned to the Meter Shop the meter and backflow will be tested for accuracy and functionality.
- d. Meter Section Staff will contact and notify Customer Services of the final read and any charges resulting from damages to the meter and backflow or its appurtenance. These charges will be added on the customer's final bill and will be sent to the address of record. Any customer who has an outstanding balance will not receive additional meters.
- e. Outstanding balances due may be deducted from deposits and any balances refunded to the customer. Any outstanding balances will be turned over to the City Treasurer for collection. Outstanding balances may also be transferred to any other existing accounts.

5. **EXCEPTIONS**

- 5.1 Any request for exceptions to this policy shall be presented, in writing, to the Customer Support Deputy Director, or his/her designee for consideration.

6. **MOBILE METER**

- 6.1 Mobile meters will be allowed on a case by case basis. All mobile meters will be protected by an approved backflow assembly and the minimum requirement will be a Reduced Pressure Principal Assembly. The two types of Mobile Meters are vehicle mounted and floating meters. Each style of meters has separate guidelines that shall be followed for the customer to retain service and are described below:

- a) **Vehicle Mounted Meters:** Customer applies for and receives a City owned Fire Hydrant Meter from the Meter Shop. The customer mounts the meter on the vehicle and brings it to the Meter Shop for

<b>CITY OF SAN DIEGO CALIFORNIA DEPARTMENT INSTRUCTIONS</b>	<b>NUMBER DI 55.27</b>	<b>DEPARTMENT Water Department</b>
<b>SUBJECT  FIRE HYDRANT METER PROGRAM (FORMERLY: CONSTRUCTION METER PROGRAM)</b>	<b>PAGE 8 OF 10</b>	<b>EFFECTIVE DATE  October 15, 2002</b>
	<b>SUPERSEDES DI 55.27</b>	<b>DATED April 21, 2000</b>

inspection. After installation is approved by the Meter Shop the vehicle and meter shall be brought to the Meter Shop on a monthly basis for meter reading and on a quarterly basis for testing of the backflow assembly. Meters mounted at the owner's expense shall have the one year contract expiration waived and shall have meter or backflow changed if either fails.

b) **Floating Meters:** Floating Meters are meters that are not mounted to a vehicle. **(Note: All floating meters shall have an approved backflow assembly attached.)** The customer shall submit an application and a letter explaining the need for a floating meter to the Meter Shop. The Fire Hydrant Meter Administrator, after a thorough review of the needs of the customer, (i.e. number of jobsites per day, City contract work, lack of mounting area on work vehicle, etc.), may issue a floating meter. At the time of issue, it will be necessary for the customer to complete and sign the "Floating Fire Hydrant Meter Agreement" which states the following:

- 1) The meter will be brought to the Meter Shop at 2797 Caminito Chollas, San Diego on the third week of each month for the monthly read by Meter Shop personnel.
- 2) Every other month the meter will be read and the backflow will be tested. This date will be determined by the start date of the agreement.

If any of the conditions stated above are not met the Meter Shop has the right to cancel the contract for floating meter use and close the account associated with the meter. The Meter Shop will also exercise the right to refuse the issuance of another floating meter to the company in question.

Any Fire Hydrant Meter using reclaimed water shall not be allowed use again with any potable water supply. The customer shall incur the cost of replacing the meter and backflow device in this instance.

<b>CITY OF SAN DIEGO CALIFORNIA DEPARTMENT INSTRUCTIONS</b>	<b>NUMBER DI 55.27</b>	<b>DEPARTMENT Water Department</b>
<b>SUBJECT  FIRE HYDRANT METER PROGRAM (FORMERLY: CONSTRUCTION METER PROGRAM)</b>	<b>PAGE 9 OF 10</b>	<b>EFFECTIVE DATE  October 15, 2002</b>
	<b>SUPERSEDES DI 55.27</b>	<b>DATED April 21, 2000</b>

7. **FEE AND DEPOSIT SCHEDULES**

7.1 **Fees and Deposit Schedules:** The fees and deposits, as listed in the Rate Book of Fees and Charges, on file with the Office of the City Clerk, are based on actual reimbursement of costs of services performed, equipment and materials. These deposits and fees will be amended, as needed, based on actual costs. Deposits, will be refunded at the end of the use of the fire hydrant meter, upon return of equipment in good working condition and all outstanding balances on account are paid. Deposits can also be used to cover outstanding balances.

All fees for equipment, installation, testing, relocation and other costs related to this program are subject to change without prior notification. The Mayor and Council will be notified of any future changes.

8. **UNAUTHORIZED USE OF WATER FROM A HYDRANT**

8.1 Use of water from any fire hydrant without a properly issued and installed fire hydrant meter is theft of City property. Customers who use water for unauthorized purposes or without a City of San Diego issued meter will be prosecuted.

8.2 If any unauthorized connection, disconnection or relocation of a fire hydrant meter, or other connection device is made by anyone other than authorized Water Department personnel, the person making the connection will be prosecuted for a violation of San Diego Municipal Code, Section 67.15. In the case of a second offense, the customer's fire hydrant meter shall be confiscated and/or the deposit will be forfeited.

8.3 Unauthorized water use shall be billed to the responsible party. Water use charges shall be based on meter readings, or estimates when meter readings are not available.

8.4 In case of unauthorized water use, the customer shall be billed for all applicable charges as if proper authorization for the water use had been obtained, including but not limited to bi-monthly service charges, installation charges and removal charges.

<b>CITY OF SAN DIEGO CALIFORNIA DEPARTMENT INSTRUCTIONS</b>	<b>NUMBER DI 55.27</b>	<b>DEPARTMENT Water Department</b>
<b>SUBJECT  FIRE HYDRANT METER PROGRAM (FORMERLY: CONSTRUCTION METER PROGRAM)</b>	<b>PAGE 10 OF 10</b>	<b>EFFECTIVE DATE  October 15, 2002</b>
	<b>SUPERSEDES DI 55.27</b>	<b>DATED April 21, 2000</b>

- 8.5 If damage occurs to Water Department property (i.e. fire hydrant meter, backflow, various appurtenances), the cost of repairs or replacements will be charged to the customer of record (applicant).

**Larry Gardner  
Water Department Director**

- Tabs: 1. Fire Hydrant Meter Application  
2. Construction & Maintenance Related Activities With No Return To Sewer  
3. Notice of Discontinuation of Service

### **APPENDIX**

**Administering Division:** Customer Support Division

**Subject Index:** Construction Meters  
Fire Hydrant  
Fire Hydrant Meter Program  
Meters, Floating or Vehicle Mounted  
Mobile Meter  
Program, Fire Hydrant Meter

**Distribution:** DI Manual Holders



# Application for Fire Hydrant Meter (EXHIBIT A)

(For Office Use Only)

NS REQ	FAC#
DATE	BY

METER SHOP (619) 527-7449

## Meter Information

Application Date	Requested Install Date:
------------------	-------------------------

Fire Hydrant Location: (Attach Detailed Map//Thomas Bros. Map Location or Construction drawing.) <u>Zip:</u>	<u>T.B.</u>	<u>G.B. (CITY USE)</u>
Specific Use of Water:		
Any Return to Sewer or Storm Drain, If so, explain:		
Estimated Duration of Meter Use: <input type="text"/>	<input type="checkbox"/>	Check Box if Reclaimed Water

## Company Information

Company Name:			
Mailing Address:			
City:	State:	Zip:	Phone: ( )
*Business license#		*Contractor license#	
A Copy of the Contractor's license OR Business License is required at the time of meter issuance.			
Name and Title of Billing Agent: <small>(PERSON IN ACCOUNTS PAYABLE)</small>			Phone: ( )
Site Contact Name and Title:			Phone: ( )
Responsible Party Name:			Title:
Cal ID#			Phone: ( )
Signature:		Date:	
Guarantees Payment of all Charges Resulting from the use of this Meter. Insures that employees of this Organization understand the proper use of Fire Hydrant Meter			

<b>Fire Hydrant Meter Removal Request</b>	Requested Removal Date:
Provide Current Meter Location if Different from Above:	
Signature:	Title: Date:
Phone: ( )	Pager: ( )

<input type="checkbox"/>	City Meter	<input type="checkbox"/>	Private Meter
Contract Acct #:		Deposit Amount: <b>\$ 936.00</b>	Fees Amount: <b>\$ 62.00</b>
Meter Serial #		Meter Size: <b>05</b>	Meter Make and Style: <b>6-7</b>
Backflow #		Backflow Size:	Backflow Make and Style:
Name: Boundary St & Edmonton Ave SMR		Signature:	Date:

**WATER USES WITHOUT ANTICIPATED CHARGES FOR RETURN TO SEWER**

Auto Detailing  
Backfilling  
Combination Cleaners (Vactors)  
Compaction  
Concrete Cutters  
Construction Trailers  
Cross Connection Testing  
Dust Control  
Flushing Water Mains  
Hydro Blasting  
Hydro Seeing  
Irrigation (for establishing irrigation only; not continuing irrigation)  
Mixing Concrete  
Mobile Car Washing  
Special Events  
Street Sweeping  
Water Tanks  
Water Trucks  
Window Washing

**Note:**

1. If there is any return to sewer or storm drain, then sewer and/or storm drain fees will be charges.

Date

Name of Responsible Party  
Company Name and Address  
Account Number: \_\_\_\_\_

Subject: Discontinuation of Fire Hydrant Meter Service

Dear Water Department Customer:

The authorization for use of Fire Hydrant Meter # \_\_\_\_\_, located at *(Meter Location Address)* ends in 60 days and will be removed on or after *(Date Authorization Expires)*. Extension requests for an additional 90 days must be submitted in writing for consideration 30 days prior to the discontinuation date. If you require an extension, please contact the Water Department, or mail your request for an extension to:

City of San Diego  
Water Department  
Attention: Meter Services  
2797 Caminito Chollas  
San Diego, CA 92105-5097

Should you have any questions regarding this matter, please call the Fire Hydrant Hotline at (619) \_\_\_\_\_ - \_\_\_\_\_.

Sincerely,

Water Department



## **APPENDIX C**

### **MATERIALS TYPICALLY ACCEPTED BY CERTIFICATE OF COMPLIANCE**

## **Materials Typically Accepted by Certificate of Compliance**

1. Soil amendment
2. Fiber mulch
3. PVC or PE pipe up to 16 inch diameter
4. Stabilizing emulsion
5. Lime
6. Preformed elastomeric joint seal
7. Plain and fabric reinforced elastomeric bearing pads
8. Steel reinforced elastomeric bearing pads
9. Waterstops (Special Condition)
10. Epoxy coated bar reinforcement
11. Plain and reinforcing steel
12. Structural steel
13. Structural timber and lumber
14. Treated timber and lumber
15. Lumber and timber
16. Aluminum pipe and aluminum pipe arch
17. Corrugated steel pipe and corrugated steel pipe arch
18. Structural metal plate pipe arches and pipe arches
19. Perforated steel pipe
20. Aluminum underdrain pipe
21. Aluminum or steel entrance tapers, pipe downdrains, reducers, coupling bands and slip joints
22. Metal target plates
23. Paint (traffic striping)
24. Conductors
25. Painting of electrical equipment
26. Electrical components
27. Engineering fabric
28. Portland Cement
29. PCC admixtures
30. Minor concrete, asphalt
31. Asphalt (oil)
32. Liquid asphalt emulsion
33. Epoxy

**APPENDIX D**  
**SAMPLE CITY INVOICE**

City of San Diego, Field Engineering Div., 9485 Aero Drive, SD CA 92123						Contractor's Name:					
Project Name:						Contractor's Address:					
SAP No. (WBS/IO/CC)											
City Purchase Order No.						Contractor's Phone #:			Invoice No.		
Resident Engineer (RE):						Contractor's Fax #:			Invoice Date:		
RE Phone#:			RE Fax#:			Contact Name:			Billing Period:		
Item #	Item Description	Contract Authorization				Previous Estimate		This Estimate		Totals to Date	
		Unit	Qty	Price	Extension	%/QTY	Amount	% / QTY	Amount	% / QTY	Amount
1	2 Parallel 4" PVC C900	LF	1,380	\$34.00	\$46,920.00						
2	48" Primary Steel Casing	LF	500	\$1,000.00	\$500,000.00						
3	2 Parallel 12" Secondary Steel	LF	1,120	\$53.00	\$59,360.00						
4	Construction and Rehab of PS 49	LS	1	\$150,000.00	\$150,000.00						
5	Demo	LS	1	\$14,000.00	\$14,000.00						
6	Install 6' High Chain Link Fence	LS	1	\$5,600.00	\$5,600.00						
7	General Site Restoration	LS	1	\$3,700.00	\$3,700.00						
8	10" Gravity Sewer	LF	10	\$292.00	\$2,920.00						
9	4" Blow Off Valves	EA	2	\$9,800.00	\$19,600.00						
10	Bonds	LS	1	\$16,000.00	\$16,000.00						
11	Field Orders	AL	1	80,000	\$80,000.00						
11.1	Field Order 1	LS	5,500	\$1.00	\$5,500.00						
11.2	Field Order 2	LS	7,500	\$1.00	\$7,500.00						
11.3	Field Order 3	LS	10,000	\$1.00	\$10,000.00						
11.4	Field Order 4	LS	6,500	\$1.00	\$6,500.00						
12	Certified Payroll	LS	1	\$1,400.00	\$1,400.00						
<b>CHANGE ORDERS</b>											
Change Order 1			4,890								
Items 1-4					\$11,250.00						
Item 5-Deduct Bid Item 3		LF	120	-\$53.00	(\$6,360.00)						
Change Order 2			160,480								
Items 1-3					\$95,000.00						
Item 4 Deduct Bid Item 1		LF	380	-\$340.00	(\$12,920.00)						
Item 5-Encrease bid Item 9		LF	8	\$9,800.00	\$78,400.00						
Change Order 3 (Close Out)			-121,500								
Item 1 Deduct Bid Item 3			53	-500.00	(\$26,500.00)						
Item 2 Deduct Bid Item 4		LS	-1	45,000.00	(\$45,000.00)						
Items 3-9			1	-50,500.00	(\$50,500.00)						
<b>SUMMARY</b>								Total This	\$ -	Total Billed	\$0.00
A. Original Contract Amount						<b>Retention and/or Escrow Payment Schedule</b>					
B. Approved Change Order 1 Thru 3						Total Retention Required as of this billing					
C. Total Authorized Amount (A+B)						Previous Retention Withheld in PO or in Escrow					
D. Total Billed to Date						Add'l Amt to Withhold in PO/Transfer in Escrow:					
E. Less Total Retention (5% of D)						Amt to Release to Contractor from PO/Escrow:					
F. Less Total Previous Payments											
G. Payment Due Less Retention						Contractor Signature and Date:					
H. Remaining Authorized Amount											

**APPENDIX E**  
**LOCATION MAP**

THIS MAP/DATA IS PROVIDED WITHOUT WARRANTY OF ANY KIND, EITHER EXPRESS OR IMPLIED, INCLUDING, BUT NOT LIMITED TO, THE IMPLIED WARRANTIES OR MERCHANTABILITY AND FITNESS FOR A PARTICULAR PURPOSE. Note: This product may contain information reproduced with permission granted by RAND McNALLY & COMPANY to SanGIS. This map is copyrighted by RAND McNALLY & COMPANY. It is unlawful to copy or reproduce all or any part thereof, whether for personal use or resale, without the prior, written permission of RAND McNALLY & COMPANY.



## LOCATION MAP BOUNDARY ST & EDMONTON AVE SMR

SENIOR ENGINEER  
RANIA AMEN  
619-533-5492

PROJECT MANAGER  
JERICHO GALLARDO  
619-533-7523

PROJECT ENGINEER  
JOSELITO GUINTO  
619-533-5474

PUBLIC INFORMATION OFFICER  
619-533-4207



**RIGHT-OF-WAY DIVISION**

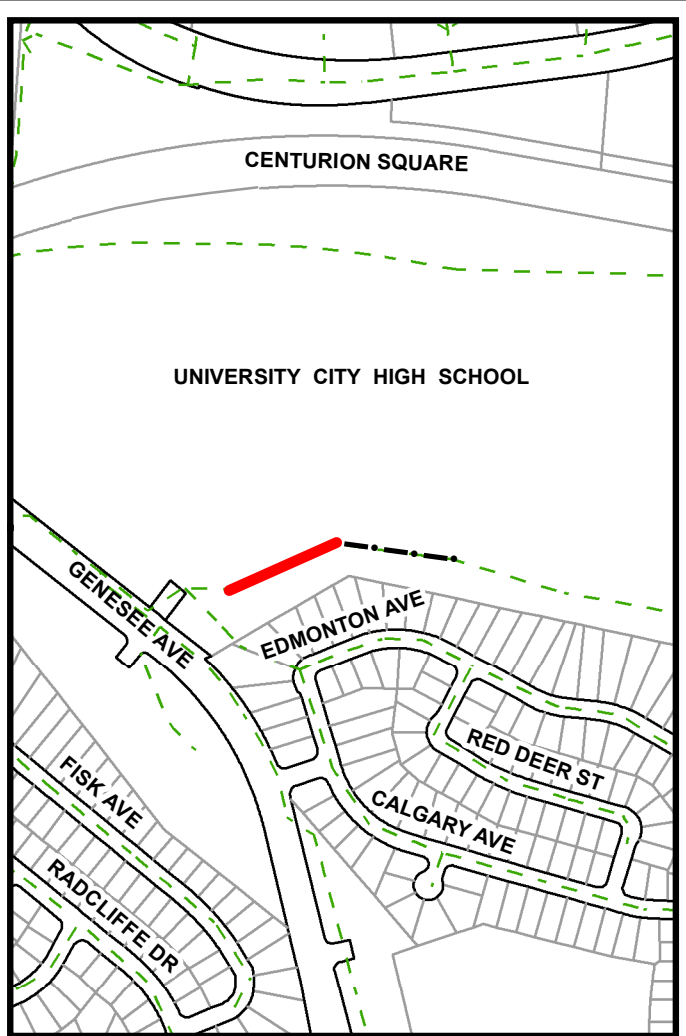
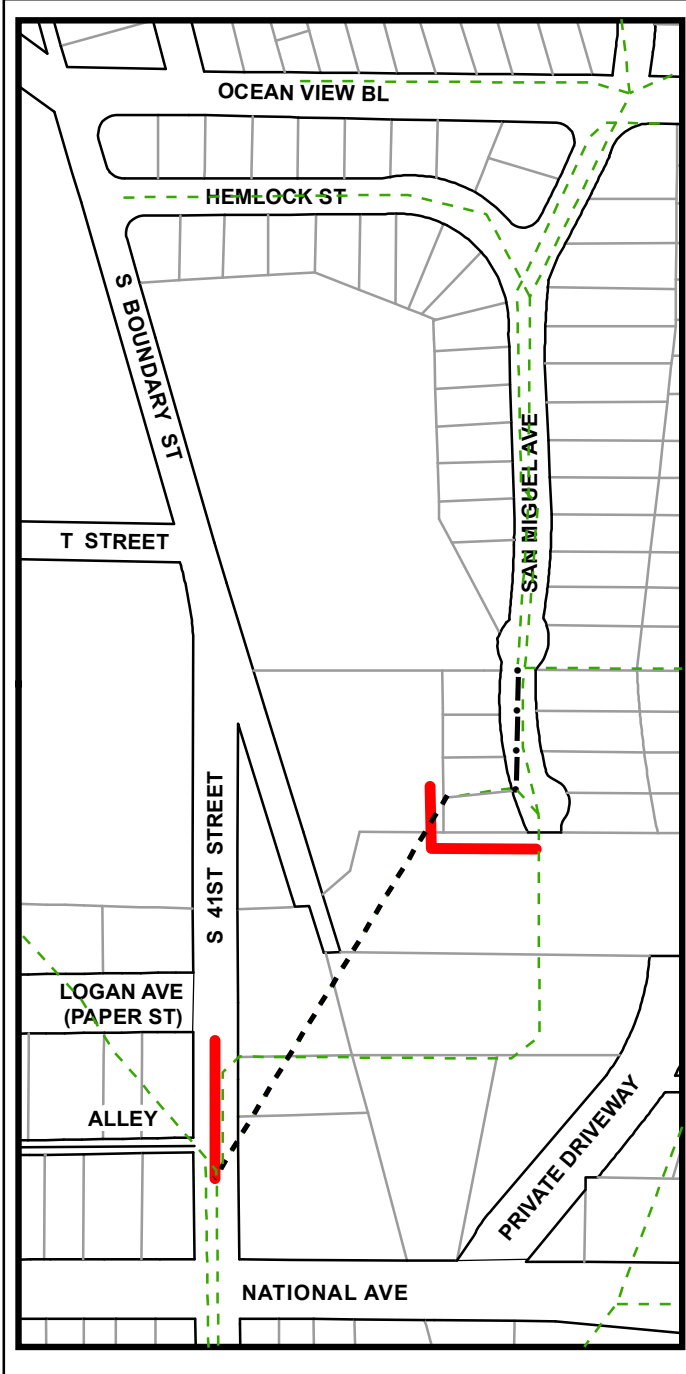

### Legend

- |  |                     |  |                            |
|--|---------------------|--|----------------------------|
|  | Proposed Sewer      |  | Sewer Main To Be Abandoned |
|  | Existing Sewer Main |  | Sewer Main To Be Rehabbed  |

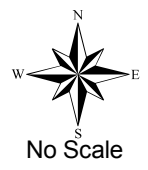

**APPENDIX F**

**REHAB DATA COLLECTION – SEWER MAINS AND MANHOLES**







**ATTACHMENT F**  
**INTENTIONALLY LEFT BLANK**

# City of San Diego

CITY CONTACT: Damian Singleton, Contract Specialist, Email: [Dsingleton@sandiego.gov](mailto:Dsingleton@sandiego.gov)  
Phone No. (619) 533-3482, Fax No. (619) 533-3633

---

## ADDENDUM "A"

## FOR



## BOUNDARY ST & EDMONTON AVE SMR

BID NO.: \_\_\_\_\_ K-15-1217-DBB-3  
SAP NO. (WBS/IO/CC): \_\_\_\_\_ B-13173  
CLIENT DEPARTMENT: \_\_\_\_\_ 2011  
COUNCIL DISTRICT: \_\_\_\_\_ 1, 9  
PROJECT TYPE: \_\_\_\_\_ JA

---

### **BID DUE DATE:**

**2:00 PM  
NOVEMBER 18, 2014  
CITY OF SAN DIEGO  
PUBLIC WORKS CONTRACTS  
1010 SECOND AVENUE, 14<sup>th</sup> FLOOR, MS 614C  
SAN DIEGO, CA 92101**

**A. CHANGES TO CONTRACT DOCUMENTS**

The following changes to the Contract Documents are hereby made effective as though originally issued with the bid package. Bidders are reminded that all previous requirements to this solicitation remain in full force and effect.

THE SUBMITTAL DATE FOR THIS PROJECT **IS STATED ON THE COVER PAGE.**

James Nagelvoort, Director  
Public Works Department

Dated: *October 22, 2014*  
San Diego, California

JN/BD/egz

Handwritten mark resembling a signature or initials.

NAME AS THE CONTRACT PARTY

# City of San Diego

CONTRACTOR'S NAME: Pullman Engineering Inc  
 ADDRESS: 6546 Barnhurst Dr San Diego, CA 92117  
 TELEPHONE NO.: 619-610-9329 FAX NO.: 619-576-1049  
 CITY CONTACT: Damian Singleton, Contract Specialist, Email: Dsingleton@sandiego.gov  
Phone No. (619) 533-3482; Fax No. (619) 533-3633  
J.Gallardo/B.Doringo/egz

## CONTRACT DOCUMENTS



## FOR

### BOUNDARY ST & EDMONTON AVE SMR

VOLUME 2 OF 2 STEWART BL ETC COMPANY

BID NO.: K-15-1217-DBB-3  
 SAP NO. (WBS/IO/CC): B-13173  
 CLIENT DEPARTMENT: 2011  
 COUNCIL DISTRICT: 1, 9  
 PROJECT TYPE: JA

**THIS CONTRACT IS SUBJECT TO THE FOLLOWING:**

- THE CITY'S SUBCONTRACTING PARTICIPATION REQUIREMENTS FOR SLBE PROGRAM.
- BID DISCOUNT PROGRAM (The WHITEBOOK, SLBE-ELBE Program Requirements, Section IV(2))
- PREVAILING WAGE RATES: STATE  FEDERAL

**THIS BIDDING DOCUMENT TO BE SUBMITTED IN ITS ENTIRETY REFER TO VOLUME 1 COVER PAGE FOR TIME, DATE, AND LOCATION**

**TABLE OF CONTENTS**

**DESCRIPTION**

**PAGE NUMBER**

**Volume 2 - Bidding Documents**

The following forms must be completed in their entirety and submitted with the Bid. Include the form(s) even if the information does not apply. Where the information does not apply write in N/A. Failure to include any of the forms may cause the Bid to be deemed **non-responsive**. If you are uncertain or have any questions about any required information, contact the City no later than 14 days prior to Bid due date.

1. Bid/Proposal.....	3
2. Bid Bond.....	6
3. Non-Collusion Affidavit to be executed by Bidder and Submitted with Bid under 23 USC 112 and PCC 7106 .....	7
4. Contractors Certification of Pending Actions .....	8
5. Equal Benefits Ordinance Certification of Compliance.....	9
6. Proposal (Bid).....	10
7. Form AA35 - List of Subcontractors .....	14
8. Form AA40 - Named Equipment/Material Supplier List .....	15

**BIDDING DOCUMENTS**

---

**PROPOSAL**

**Bidder's General Information**

To the City of San Diego:

Pursuant to "Notice Inviting Bids", specifications, and requirements on file with the City Clerk, and subject to all provisions of the Charter and Ordinances of the City of San Diego and applicable laws and regulations of the United States and the State of California, the undersigned hereby proposes to furnish to the City of San Diego, complete at the prices stated herein, the items or services hereinafter mentioned. The undersigned further warrants that this bid is not made in the interest of, or on behalf of, any undisclosed person, partnership, company, association, organization, or corporation; that the bid is genuine and not collusive or sham; that the bidder has not directly or indirectly induced or solicited any other bidder to put in a false or sham bid, and has not directly or indirectly colluded, conspired, connived, or agreed with any bidder or anyone else to put in a sham bid, or that anyone shall refrain from bidding; that the bidder has not in any manner, directly or indirectly, sought by agreement, communication, or conference with anyone to fix the bid price of the bidder or any other bidder, or to fix any overhead, profit, or cost element of the bid price, or of that of any other bidder, or to secure any advantage against the public body awarding the contract of anyone interested in the proposed contract; that all statements contained in the bid are true; and, further, that the bidder has not, directly or indirectly, submitted his or her bid price or any breakdown thereof, or the contents thereof, or divulged information or data relative thereto, or paid, and will not pay, any fee to any corporation, partnership, company, association, organization, bid depository, or to any member or agent thereof to effectuate a collusive or sham bid.

The undersigned bidder(s) further warrants that bidder(s) has thoroughly examined and understands the entire Contract Documents (plans and specifications) and the Bidding Documents therefore, and that by submitting said Bidding Documents as its bid proposal, bidder(s) acknowledges and is bound by the entire Contract Documents, including any addenda issued thereto, as such Contract Documents incorporated by reference in the Bidding Documents.

**IF A SOLE OWNER OR SOLE CONTRACTOR SIGN HERE:**

- (1) Name under which business is conducted \_\_\_\_\_
- (2) Signature (Given and surname) of proprietor \_\_\_\_\_
- (3) Place of Business (Street & Number) \_\_\_\_\_
- (4) City and State \_\_\_\_\_ Zip Code \_\_\_\_\_
- (5) Telephone No. \_\_\_\_\_ Facsimile No. \_\_\_\_\_
- (6) Email Address \_\_\_\_\_

**IF A PARTNERSHIP, SIGN HERE:**

- (1) Name under which business is conducted \_\_\_\_\_

**BIDDING DOCUMENTS**

---

(2) Name of each member of partnership, indicate character of each partner, general or special (limited):

\_\_\_\_\_  
\_\_\_\_\_

(3) Signature (Note: Signature must be made by a general partner)

\_\_\_\_\_

Full Name and Character of partner

\_\_\_\_\_  
\_\_\_\_\_

(4) Place of Business (Street & Number) \_\_\_\_\_

(5) City and State \_\_\_\_\_ Zip Code \_\_\_\_\_

(6) Telephone No. \_\_\_\_\_ Facsimile No. \_\_\_\_\_

(7) Email Address \_\_\_\_\_

**IF A CORPORATION, SIGN HERE:**

(1) Name under which business is conducted Pullman Engineering Inc.

(2) Signature, with official title of officer authorized to sign for the corporation:

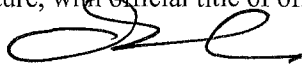

(Signature)

Chris Pullman

(Printed Name)

President

(Title of Officer)

(Impress Corporate Seal Here)

(3) Incorporated under the laws of the State of CA

(4) Place of Business (Street & Number) 6546 Barnhurst Dr.

(5) City and State San Diego CA Zip Code 92117

(6) Telephone No. 858 610 9329 Facsimile No. 858 576-1049

(7) Email Address Chris@pullmaneng.com



**BIDDING DOCUMENTS**

**THE FOLLOWING SECTIONS MUST BE FILLED IN BY ALL PROPOSERS:**

In accordance with the "NOTICE INVITING BIDS", the bidder holds a California State Contractor's license for the following classification(s) to perform the work described in these specifications:

LICENSE CLASSIFICATION A

LICENSE NO. 770533 EXPIRES 10-31-2015

This license classification must also be shown on the front of the bid envelope. Failure to show license classification on the bid envelope may cause return of the bid unopened.

TAX IDENTIFICATION NUMBER (TIN): [REDACTED]

Email Address: Chris E pullmaneng.com

**THIS PROPOSAL MUST BE NOTARIZED BELOW:**

I certify, under penalty of perjury, that the representations made herein regarding my State Contractor's license number, classification and expiration date are true and correct.

Signature [Signature] Title Pres.

SUBSCRIBED AND SWORN TO BEFORE ME, THIS \_\_\_\_\_ DAY OF \_\_\_\_\_.

Notary Public in and for the County of Ma, State of \_\_\_\_\_

(NOTARIAL SEAL)

State of California  
County of San Diego  
Subscribed and sworn to (or affirmed) before me on this 18th day of November, 2014, by Chris Pullman  
I provided me on the basis of satisfactory evidence to be the person whose name is subscribed to the foregoing instrument and appeared before me.  
M. Edlds  
Signature of Notary Public

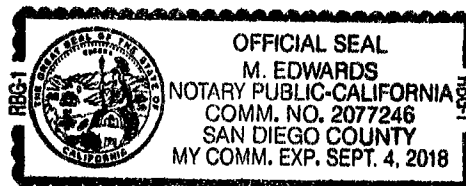

**BIDDING DOCUMENTS**

**BID BOND**

KNOW ALL MEN BY THESE PRESENTS,

That Pullman Engineering, Inc. as Principal, and State National Insurance Company, Inc. administered by: Contractor Managing General Insurance Agency, Inc. as Surety, are held and firmly bound unto The City of San Diego hereinafter called "OWNER," in the sum of **10% OF THE TOTAL BID AMOUNT** for the payment of which sum, well and truly to be made, we bind ourselves, our heirs, executors, administrators, successors, and assigns, jointly and severally, firmly by these presents. \*20335 Ventura Blvd. Suite 426 Woodland Hills, CA 91364

WHEREAS, said Principal has submitted a Bid to said OWNER to perform the WORK required under the bidding schedule(s) of the OWNER's Contract Documents entitled Boundary St. & Edmonton Ave SMR

NOW THEREFORE, if said Principal is awarded a contract by said OWNER and, within the time and in the manner required in the "Notice Inviting Bids" enters into a written Agreement on the form of agreement bound with said Contract Documents, furnishes the required certificates of insurance, and furnishes the required Performance Bond and Payment Bond, then this obligation shall be null and void, otherwise it shall remain in full force and effect. In the event suit is brought upon this bond by said OWNER and OWNER prevails, said Surety shall pay all costs incurred by said OWNER in such suit, including a reasonable attorney's fee to be fixed by the court.

SIGNED AND SEALED, this 17th day of November, 2014

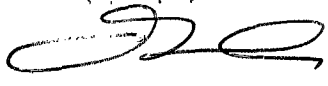
Pullman Engineering, Inc. (SEAL)  
(Principal)  
  
By: FDG (Signature)

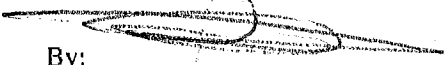
State National Insurance Company, Inc. administered by:  
Contractor Managing General Insurance Agency, Inc. (SEAL)  
(Surety)  
  
By: Stephanie Hope Shear (Signature)  
Attorney-In-Fact

(SEAL AND NOTARIAL ACKNOWLEDGEMENT OF SURETY)

**SEE ATTACHED  
FOR NOTARY CERTIFICATE**

# CALIFORNIA ALL-PURPOSE CERTIFICATE OF ACKNOWLEDGMENT

State of California

County of San Diego

On Nov. 18, 2014 before me, M. Edwards Notary Public  
(Here insert name and title of the officer)

personally appeared Chris Pullman

who proved to me on the basis of satisfactory evidence to be the person(s) whose name(s) is/are subscribed to the within instrument and acknowledged to me that he/she/they executed the same in his/her/their authorized capacity(ies), and that by his/her/their signature(s) on the instrument the person(s), or the entity upon behalf of which the person(s) acted, executed the instrument.

I certify under PENALTY OF PERJURY under the laws of the State of California that the foregoing paragraph is true and correct.

WITNESS my hand and official seal.

M. Edwards

Signature of Notary Public

(Notary Seal)

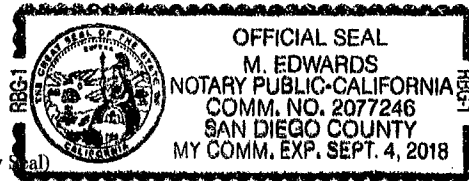

## ADDITIONAL OPTIONAL INFORMATION

### DESCRIPTION OF THE ATTACHED DOCUMENT

Bid Bond

(Title or description of attached document)

(Title or description of attached document continued)

Number of Pages 6 Document Date 11/18/2014

n/a

(Additional information)

### CAPACITY CLAIMED BY THE SIGNER

- Individual (s)
- Corporate Officer
- \_\_\_\_\_ (Title)
- Partner(s)
- Attorney-in-Fact
- Trustee(s)
- Other \_\_\_\_\_

### INSTRUCTIONS FOR COMPLETING THIS FORM

Any acknowledgment completed in California must contain verbiage exactly as appears above in the notary section or a separate acknowledgment form must be properly completed and attached to that document. The only exception is if a document is to be recorded outside of California. In such instances, any alternative acknowledgment verbiage as may be printed on such a document so long as the verbiage does not require the notary to do something that is illegal for a notary in California (i.e. certifying the authorized capacity of the signer). Please check the document carefully for proper notarial wording and attach this form if required.

- State and County information must be the State and County where the document signer(s) personally appeared before the notary public for acknowledgment.
- Date of notarization must be the date that the signer(s) personally appeared which must also be the same date the acknowledgment is completed.
- The notary public must print his or her name as it appears within his or her commission followed by a comma and then your title (notary public).
- Print the name(s) of document signer(s) who personally appear at the time of notarization.
- Indicate the correct singular or plural forms by crossing off incorrect forms (i.e. he/she/they- is /are ) or circling the correct forms. Failure to correctly indicate this information may lead to rejection of document recording.
- The notary seal impression must be clear and photographically reproducible. Impression must not cover text or lines. If seal impression smudges, re-seal if a sufficient area permits, otherwise complete a different acknowledgment form.
- Signature of the notary public must match the signature on file with the office of the county clerk.
  - ❖ Additional information is not required but could help to ensure this acknowledgment is not misused or attached to a different document.
  - ❖ Indicate title or type of attached document, number of pages and date.
  - ❖ Indicate the capacity claimed by the signer. If the claimed capacity is a corporate officer, indicate the title (i.e. CEO, CFO, Secretary).
- Securely attach this document to the signed document

State National Insurance Company, Inc. Administered by:  
**CONTRACTOR MANAGING GENERAL INSURANCE AGENCY, INC.**

**POWER OF ATTORNEY**

KNOW BY ALL THESE PRESENTS That STATE NATIONAL INSURANCE COMPANY, INC. a corporation organized and existing under the laws of the State of Texas, having its principal office in Bedford, Texas does hereby constitute and appoint

Stephanie Hope Shear

its true and lawful attorney(s)-in-fact to execute, seal and deliver for and on its behalf as surety, the following bond described as:

City of San Diego - Boundary St. & Edmonton Ave SMR

for: Three Million and 00/100 Dollars (\$3,000,000)

and undertakings, contracts of indemnity and other writings obligatory in the nature thereof, which are or may be allowed, required or permitted by law, statute, rule, regulation, contract or otherwise.

The execution of such instrument(s) in pursuance of these present, shall be as binding upon STATE NATIONAL INSURANCE COMPANY, INC. as fully and amply, to all intents and purposes, as if the same had been duly executed and acknowledged by its regularly elected officers at the principal office.

RESOLVED that the signature of any authorized officer and the seal of the Company may be affixed by facsimile to any Power of Attorney or certification thereof authorizing the execution and delivery of any bond, undertaking, contracts of indemnity and other writings obligatory in the nature thereof, and such signature and seal when so used shall have the same force and effect as though manually affixed.

IN WITNESS WHEREOF, STATE NATIONAL INSURANCE COMPANY, INC. has caused this instrument to be signed and its corporate seal to be affixed by its authorized officer, this 24th day of March, 2014.

STATE NATIONAL INSURANCE COMPANY, INC.

Terry L. Ledbetter, President

Trace Ledbetter, Secretary

STATE OF TEXAS  
County of Tarrant

On this 24th day of March, 2014 before me came the individuals who executed the preceding instrument, to me personally known, and being by me duly sworn, said that each of the herein described and authorized officer of STATE NATIONAL INSURANCE COMPANY, INC.; that the seal affixed to said instrument is the Corporate Seal of said Company; that the Corporate Seal and each signature were duly affixed by order of the Board of Directors of said Company.

IN WITNESS WHEREOF, I have hereunto set my hand at Bedford, Texas the day and year above written.

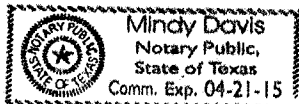

[Notary Stamp]

Signature of Notary

I, Trace Ledbetter, Secretary of STATE NATIONAL INSURANCE COMPANY, INC., do hereby certify that the above and foregoing is a true and correct copy of a Power of Attorney executed by STATE NATIONAL INSURANCE COMPANY, INC., which is still in full force and effect.

IN WITNESS WHEREOF, I have thereunto set my hand and attested the seal of said Company this 17th day of November, 20 14

Trace Ledbetter, Secretary

**CALIFORNIA ALL – PURPOSE ACKNOWLEDGEMENT**

State of California

County of Los Angeles

On NOV 17 2014 before me, JAN MICHELLE RIVERA, NOTARY PUBLIC  
DATE NAME, TITLE OF OFFICER

Personally appeared STEPHANIE HOPE SHEAR,  
NAME(S) OF SIGNER(S)

Who proved to me on the basis of satisfactory evidence to be the person(s) whose name(s) is/are subscribed to the within instrument and acknowledged to me that he/she/they executed the same in his/her/their authorized capacity(ies), and that by his/her/their signature(s) on the instrument the person(s), or the entity upon behalf of which the person(s) acted, executed the instrument.

I certify under PENALTY OF PERJURY under the laws of the State of California that the foregoing paragraph is true and correct.

WITNESS my hand and official seal.

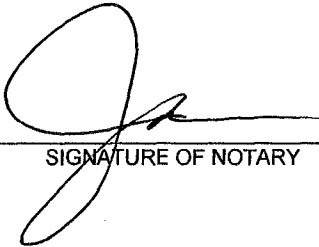
  
SIGNATURE OF NOTARY



NOTARY SEAL

BIDDING DOCUMENTS

NON-COLLUSION AFFIDAVIT TO BE EXECUTED BY BIDDER AND SUBMITTED WITH BID UNDER 23 UNITED STATES CODE 112 AND PUBLIC CONTRACT CODE 7106

State of California )
County of San Diego ) ss.

being first duly sworn, deposes and says that he or she is of the party making the foregoing bid that the bid is not made in the interest of, or on behalf of, any undisclosed person, partnership, company, association, organization, or corporation; that the bid is genuine and not collusive or sham; that the bidder has not directly or indirectly induced or solicited any other bidder to put in a false or sham bid, and has not directly or indirectly colluded, conspired, connived, or agreed with any bidder or anyone else to put in a sham bid, or that anyone shall refrain from bidding; that the bidder has not in any manner, directly or indirectly, sought by agreement, communication, or conference with anyone to fix the bid price of the bidder or any other bidder, or to fix any overhead, profit, or cost element of the bid price, or of that of any other bidder, or to secure any advantage against the public body awarding the contract of anyone interested in the proposed contract; that all statements contained in the bid are true; and further, that the bidder has not, directly or indirectly, submitted his or her bid price or any breakdown thereof, or the contents thereof, or divulged information or data relative thereto, or paid, and will not pay, any fee to any corporation, partnership, company association, organization, bid depository, or to any member or agent thereof to effectuate a collusive or sham bid.

Signed: [Signature]
Title: Pres.

State of California
County of San Diego
Subscribed and sworn to (or affirmed) before me on this 18th day of November 2014 by Chris Pullman
Subscribed and sworn to before me this n/a day of , 20
proved to me on the basis of satisfactory evidence to be the person who appeared before me.

M. Edrks
Signature of Notary Public

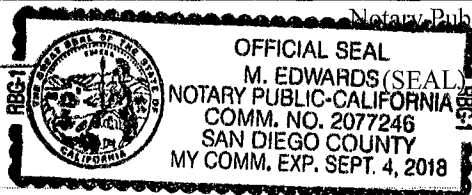

**BIDDING DOCUMENTS**

**CONTRACTORS CERTIFICATION OF PENDING ACTIONS**

As part of its bid or proposal (Non-Price Proposal in the case of Design-Build contracts), the Bidder shall provide to the City a list of all instances within the past 10 years where a complaint was filed or pending against the Bidder in a legal or administrative proceeding alleging that Bidder discriminated against its employees, subcontractors, vendors or suppliers, and a description of the status or resolution of that complaint, including any remedial action taken.

CHECK ONE BOX ONLY.

- The undersigned certifies that within the past 10 years the Bidder has NOT been the subject of a complaint or pending action in a legal administrative proceeding alleging that Bidder discriminated against its employees, subcontractors, vendors or suppliers.
  
- The undersigned certifies that within the past 10 years the Bidder has been the subject of a complaint or pending action in a legal administrative proceeding alleging that Bidder discriminated against its employees, subcontractors, vendors or suppliers. A description of the status or resolution of that complaint, including any remedial action taken and the applicable dates is as follows:

DATE OF CLAIM	LOCATION	DESCRIPTION OF CLAIM	LITIGATION (Y/N)	STATUS	RESOLUTION/REMEDIAL ACTION TAKEN

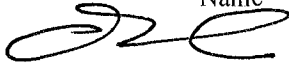
Contractor Name: Pullman Engineering Inc  
Certified By Chris Pullman Title President  
Name  
 Date 11-18-14  
Signature

**USE ADDITIONAL FORMS AS NECESSARY**





**BIDDING DOCUMENTS**

**PROPOSAL (BID)**

The Bidder agrees to the construction of **Boundary St & Edmonton Ave SMR**, for the City of San Diego, in accordance with these contract documents for the prices listed below. The Bidder guarantees the Contract Price for a period of 120 days (90 days for federally funded contracts and contracts valued at \$500,000 or less) from the date of Bid opening to Award of the Contract. The duration of the Contract Price guarantee shall be extended by the number of days required for the City to obtain all items necessary to fulfill all conditions precedent e.g., bond and insurance.

Item	Quantity	Unit	NAICS	Payment Reference	Description	Unit Price	Extension
<b>BASE BID</b>							
1	1	LS	524126	2-4.1	Bonds (Payment and Performance)	<del>                    </del>	\$ 15,000
2	1	LS	238990	7-9.1.1	Video Recording of Pre-existing Conditions	<del>                    </del>	\$ 600
3	1	LS	237310	7-10.2.6	Traffic Control	<del>                    </del>	\$ 2,500
4	1	LS	237110	9-3.4.1	Mobilization	<del>                    </del>	\$ 13,000
5	1	AL		9-3.5	Field Orders - Type II	<del>                    </del>	\$24,000
6	11,100	SF	237310	302-4.12.4	Rubber Polymer Modified Slurry Type II and Striping	\$ .67	\$ 7,437.00
7	1,200	SF	237310	302-5.2.1	Pavement Restoration Adjacent to Trench	\$ 3.14	\$ 3,768.00
8	200	LB	237310	302-14.5	Crack Seal	\$ 30.09	\$ 6,018.00
9	1	EA	237310	303-5.9	Contractor Date Stamp and Impressions	\$ 165.00	\$ 165
10	15	LF	237310	303-5.9	Additional Curb and Gutter	\$ 38.50	\$ 577.50
11	100	SF	237310	303-5.9	Additional Sidewalk Removal and Replacement	\$ 11.00	\$ 1,100.00
12	385	SF	237310	303-5.9	Concrete Driveway (Contiguous)	\$ 16.50	\$ 6,352.50
13	2	EA	237310	303-5.10.2	Curb Ramp Type D with Detectable Warning Tiles	\$ 2420	\$ 4,840.00
14	1	LS	237110	306-1.1.6	Trench Shoring	<del>                    </del>	\$ 9,540.00
15	18	CY	237110	306-1.2.1.1	Additional Bedding	\$ 22.00	\$ 396.00
16	21	TON	237310	306-1.5.1	Temporary Resurfacing	\$ 140.00	\$ 2,940.00
17	222	TON	237110	306-1.6	Imported Backfill	\$ 20.00	\$ 4,440.00
18	215	LF	237110	306-1.6	8-Inch Sewer Main	\$ 146.00	\$ 31,390.00

**BIDDING DOCUMENTS**

Item	Quantity	Unit	NAICS	Payment Reference	Description	Unit Price	Extension
19	342	LF	237110	306-1.6	8-Inch Sewer Main, Special Strength SDR-26	\$ 275.00	\$ 94050.00
20	186	LF	237110	306-1.6	10-Inch Sewer Main, Special Strength SDR-26	\$ 236.00	\$ 43,896.00
21	2	EA	237110	306-1.9.1	Sewer Lateral Connection	\$ 1,200.00	\$ 2,400.00
22	4	EA	237110	306-1.8.6	Manholes (4 x 3)	\$ 7040	\$ 28,160.00
23	2	EA	237110	306-1.8.6	Manholes (4 x 3), with Locking Device	\$ 6490	\$ 12,980.00
24	1	EA	237110	306-1.8.6	Manholes (6 x 3), with Locking Device	\$ 16,850	\$ 16,850.00
25	2	EA	237110	306-1.9.2.5	4-Inch Sewer Lateral with Private Replumbing	\$ 6,000.00	\$ 12,000.00
26	3	EA	237110	306-1.9.2.5	4-Inch Trenchless Method for Private Replumbing	\$ 9,500.00	\$ 28,500.00
27	1	EA	561730	308-7	Remove & Dispose (1 Palm Tree)	\$ 1500.00	\$ 1,500.00
28	3	EA	237110	306-5.3	Abandon Existing Manhole Outside of Trench	\$ 1,800.00	\$ 5,400.00
29	709	LF	237110	306-5.3	Abandon and Fill Existing 10-Inch Sewer Main Outside of Trench Limit	\$ 10	\$ 7090.00
30	1,210	LF	237110	306-9.7	Video Inspecting Pipelines and Culverts for Acceptance	\$ 1	\$ 1210.00
31	1,200	LF	237110	306-9.7	Cleaning and Video Inspecting Pipelines and Culverts	\$ 1.70	\$ 2040.00
32	300	LF	237110	500-1.1.9	Rehabilitate 8-Inch Sewer Main	\$ 56.21	\$ 16,863.00
33	167	LF	237110	500-1.1.9	Rehabilitate 10-Inch Sewer Main	\$ 94.20	\$ 15,731.40
34	6	EA	237110	500-1.6.2.6	Service Lateral Connection	\$ 2,090	\$ 12,540.00
35	3	EA	237110	500-2.10.2	Rehabilitate Existing Manhole	\$ 5897.41	\$ 17,692.23
36	1	LS	541330	701-13.9.5	Water Pollution Control Program Development		\$
37	1	LS	237990	701-13.9.5	Water Pollution Control Program Implementation		\$
38	1	LS	237110	704-4	Sewage Bypass and Pumping Plan (Diversion Plan)		\$ 3500.00
<b>ESTIMATED TOTAL BASE BID:</b>							<b>\$456,466.63</b>

TOTAL BID PRICE FOR BID (Items 1 through 38 inclusive) amount written in words:

**BIDDING DOCUMENTS**

The Bid shall contain an acknowledgment of receipt of all addenda, the numbers of which shall be filled in on the Bid form. If an addendum or addenda has been issued by the City and not noted as being received by the Bidder, this proposal shall be rejected as being **non-responsive**. The following addenda have been received and are acknowledged in this bid: A

The names of all persons interested in the foregoing proposal as principals are as follows:

Chris Pullman - President  
Julia Pullman - Secretary

IMPORTANT NOTICE: If Bidder or other interested person is a corporation, state secretary, treasurer, and manager thereof; if a co-partnership, state true name of firm, also names of all individual co-partners composing firm; if Bidder or other interested person is an individual, state first and last names in full.

Bidder: Pullman Engineering Inc  
Title: Chris Pullman - President      Julia Pullman - Secretary  
Business Address: 6546 Barnhurst Dr San Diego, CA 92117  
Place of Business: Same  
Place of Residence: Same  
Signature: 

## BIDDING DOCUMENTS

---

### NOTES:

- A. The City shall determine the low Bid based on the Base Bid alone.
- B. Prices and notations shall be in ink or typewritten. All corrections (which have been initiated by the Bidder using erasures, strike out, line out, or "white-out") shall be typed or written in with ink adjacent thereto, and shall be initialed in ink by the person signing the bid proposal.
- C. Failure to initial all corrections made in the bidding documents may cause the Bid to be rejected as **non-responsive** and ineligible for further consideration.
- D. Blank spaces must be filled in, using figures. Bidder's failure to submit a price for any Bid item that requires the Bidder to submit a price shall render the Bid **non-responsive** and shall be cause for its rejection.
- E. Unit prices shall be entered for all unit price items. Unit prices shall not exceed two (2) decimal places. If the Unit prices entered exceed two (2) decimal places, the City will only use the first two digits after the decimal points without rounding up or down.
- F. All extensions of the unit prices bid will be subject to verification by the City. In the case of inconsistency or conflict between the product of the Quantity x Unit Price and the Extension, the product shall govern.
- G. In the case of inconsistency or conflict, between the sums of the Extensions with the estimated total Bid, the sum of the Extensions shall govern.
- H. Bids shall not contain any recapitulation of the Work. Conditional Bids will be rejected as being **non-responsive**. Alternative proposals will not be considered unless called for.
- I. Subcontractors' License Number must be filled in. Failure to provide the information specified may deem the bidder **non-responsive**.

**BIDDING DOCUMENTS**

**LIST OF SUBCONTRACTORS**

In accordance with the requirements provided in the "Subletting and Subcontracting Fair Practices Act", Division 2, Part 1, Chapter 4 of the Public Contract Code, the Bidder shall list below the name and address of each Subcontractor who will perform work, labor, render services or specially fabricates and installs a portion [type] of the work or improvement, in an amount in excess of 0.5% of the Contractor's total Bid. The Bidder shall also list below the portion of the work which will be done by each subcontractor under this Contract. The Contractor shall list only one Subcontractor for each portion of the Work. The **DOLLAR VALUE** of the total Bid to be performed shall be stated for all subcontractors listed. Failure to comply with this requirement shall result in the Bid being rejected as **non-responsive** and ineligible for award. The Bidder's attention is directed to the Special Provisions - General; Paragraph 2-3 Subcontracts, which stipulates the percent of the Work to be performed with the Bidders' own forces. The Bidder shall list all SLBE, ELBE, DBE, DVBE, MBE, WBE, OBE, SDB, WoSB, HUBZone, and SDVOSB Subcontractors that Bidders are seeking recognition towards achieving any mandatory, voluntary, or both subcontracting participation percentages.

Subcontractors' License Number must be filled in. Failure to provide the information specified may deem the bidder **non-responsive**.

NAME, ADDRESS AND TELEPHONE NUMBER OF SUBCONTRACTOR	CONSTRUCTOR OR DESIGNER	SUBCONTRACTOR LICENSE NUMBER	TYPE OF WORK	DOLLAR VALUE OF SUBCONTRACT (MUST BE FILLED OUT)	MBE, WBE, DBE, DVBE, OBE, ELBE, SLBE, SDB, WoSB, HUBZone, OR SDVOSB	WHERE CERTIFIED ②	CHECK IF JOINT VENTURE PARTNERSHIP
Name: <u>G SCOTT ASPHALT INC</u> Address: <u>358 TROUSDALE DR</u> City: <u>CANA VISTA</u> State: <u>CA</u> Zip: <u>91910</u> Phone: <u>619-420-1884</u> Email:		751836	# 6 Slurry	6750			
Name: _____ Address: _____ City: _____ State: _____ Zip: _____ Phone: _____ Email: _____							

① As appropriate, Bidder shall identify Subcontractor as one of the following and shall include a valid proof of certification (except for OBE, SLBE and ELBE):

- |   |        |  |         |
|---|--------|--|---------|
| Certified Minority Business Enterprise        | MBE    | Certified Woman Business Enterprise            | WBE     |
| Certified Disadvantaged Business Enterprise   | DBE    | Certified Disabled Veteran Business Enterprise | DVBE    |
| Other Business Enterprise                     | OBE    | Certified Emerging Local Business Enterprise   | ELBE    |
| Certified Small Local Business Enterprise     | SLBE   | Small Disadvantaged Business                   | SDB     |
| Woman-Owned Small Business                    | WoSB   | HUBZone Business                               | HUBZone |
| Service-Disabled Veteran Owned Small Business | SDVOSB |  |         |

② As appropriate, Bidder shall indicate if Subcontractor is certified by:

- |  |        |  |          |
|--|--------|--|----------|
| City of San Diego                                    | CITY   | State of California Department of Transportation       | CALTRANS |
| California Public Utilities Commission               | CPUC   | San Diego Regional Minority Supplier Diversity Council | SRMSDC   |
| State of California's Department of General Services | CADoGS | City of Los Angeles                                    | LA       |
| State of California                                  | CA     | U.S. Small Business Administration                     | SBA      |

29.53

**The Bidder will not receive any subcontracting participation percentages if the Bidder fails to submit the required proof of certification.**

**BIDDING DOCUMENTS**

**LIST OF SUBCONTRACTORS**

In accordance with the requirements provided in the "Subletting and Subcontracting Fair Practices Act", Division 2, Part 1, Chapter 4 of the Public Contract Code, the Bidder shall list below the name and address of each Subcontractor who will perform work, labor, render services or specially fabricates and installs a portion [type] of the work or improvement, in an amount in excess of 0.5% of the Contractor's total Bid. The Bidder shall also list below the portion of the work which will be done by each subcontractor under this Contract. The Contractor shall list only one Subcontractor for each portion of the Work. The **DOLLAR VALUE** of the total Bid to be performed shall be stated for all subcontractors listed. Failure to comply with this requirement shall result in the Bid being rejected as **non-responsive** and ineligible for award. The Bidder's attention is directed to the Special Provisions - General; Paragraph 2-3 Subcontracts, which stipulates the percent of the Work to be performed with the Bidders' own forces. The Bidder shall list all SLBE, ELBE, DBE, DVBE, MBE, WBE, OBE, SDB, WoSB, HUBZone, and SDVOSB Subcontractors that Bidders are seeking recognition towards achieving any mandatory, voluntary, or both subcontracting participation percentages.

Subcontractors' License Number must be filled in. Failure to provide the information specified may deem the bidder **non-responsive**.

NAME, ADDRESS AND TELEPHONE NUMBER OF SUBCONTRACTOR	CONSTRUCTOR OR DESIGNER	SUBCONTRACTOR LICENSE NUMBER	TYPE OF WORK	DOLLAR VALUE OF SUBCONTRACT (MUST BE FILLED OUT)	MBE, WBE, DBE, DVBE, OBE, ELBE, SLBE, SDB, WoSB, HUBZone, OR SDVOSB	WHERE CERTIFIED	CHECK IF JOINT VENTURE PARTNERSHIP
Name: <u>RC STRUCTURES</u> Address: <u>1605 LA MIRADA AVE</u> City: <u>SAN MARINO</u> State: <u>CA</u> Zip: <u>92078</u> Phone: <u>760-744-3355</u> Email:		<u>425215</u>	<u>MANHOLES</u>	<u>33545</u>			
Name: <u>GEO-CELL SOLUTIONS, INC</u> Address: <u>2668 N. FIDELITY AVE</u> City: <u>FRESNO</u> State: <u>CA</u> Zip: <u>93727</u> Phone: <u>559-244-1557</u> Email:		<u>938053</u>	<u>PIPE ABANDONMENT</u>	<u>6900</u>	<u>DVBE</u>	<u>CA.</u>	

① As appropriate, Bidder shall identify Subcontractor as one of the following and shall include a valid proof of certification (except for OBE, SLBE and ELBE):

Certified Minority Business Enterprise	MBE	Certified Woman Business Enterprise	WBE
Certified Disadvantaged Business Enterprise	DBE	Certified Disabled Veteran Business Enterprise	DVBE
Other Business Enterprise	OBE	Certified Emerging Local Business Enterprise	ELBE
Certified Small Local Business Enterprise	SLBE	Small Disadvantaged Business	SDB
Woman-Owned Small Business	WoSB	HUBZone Business	HUBZone
Service-Disabled Veteran Owned Small Business	SDVOSB		

② As appropriate, Bidder shall indicate if Subcontractor is certified by:

City of San Diego	CITY	State of California Department of Transportation	CALTRANS
California Public Utilities Commission	CPUC	San Diego Regional Minority Supplier Diversity Council	SRMSDC
State of California's Department of General Services	CADoGS	City of Los Angeles	LA
State of California	CA	U.S. Small Business Administration	SBA

**The Bidder will not receive any subcontracting participation percentages if the Bidder fails to submit the required proof of certification.**

**BIDDING DOCUMENTS**

**LIST OF SUBCONTRACTORS**

In accordance with the requirements provided in the "Subletting and Subcontracting Fair Practices Act", Division 2, Part 1, Chapter 4 of the Public Contract Code, the Bidder shall list below the name and address of each Subcontractor who will perform work, labor, render services or specially fabricates and installs a portion [type] of the work or improvement, in an amount in excess of 0.5% of the Contractor's total Bid. The Bidder shall also list below the portion of the work which will be done by each subcontractor under this Contract. The Contractor shall list only one Subcontractor for each portion of the Work. The **DOLLAR VALUE** of the total Bid to be performed shall be stated for all subcontractors listed. Failure to comply with this requirement shall result in the Bid being rejected as **non-responsive** and ineligible for award. The Bidder's attention is directed to the Special Provisions - General; Paragraph 2-3 Subcontracts, which stipulates the percent of the Work to be performed with the Bidders' own forces. The Bidder shall list all SLBE, ELBE, DBE, DVBE, MBE, WBE, OBE, SDB, WoSB, HUBZone, and SDVOSB Subcontractors that Bidders are seeking recognition towards achieving any mandatory, voluntary, or both subcontracting participation percentages.

Subcontractors' License Number must be filled in. Failure to provide the information specified may deem the bidder **non-responsive**.

NAME, ADDRESS AND TELEPHONE NUMBER OF SUBCONTRACTOR	CONSTRUCTOR OR DESIGNER	SUBCONTRACTOR LICENSE NUMBER	TYPE OF WORK	DOLLAR VALUE OF SUBCONTRACT (MUST BE FILLED OUT)	MBE, WBE, DBE, DVBE, OBE, ELBE, SLBE, SDB, WoSB, HUBZone, OR SDVOSB	WHERE CERTIFIED ②	CHECK IF JOINT VENTURE PARTNERSHIP
Name: <u>PAVCO SPECIALTIES INC</u> Address: <u>120 N ZAVIE</u> City: <u>CHULA VISTA</u> State: <u>CA</u> Zip: <u>91910</u> Phone: <u>619-422-9204</u> Email:		<u>298637</u>	<u>STRIPING</u>	<u>1280-</u>	<u>WDBE, DBE, SDB</u>		
Name: <u>SANCO</u> Address: <u>5241 EDGEMOOR DR</u> City: <u>HUNTINGTON BEACH</u> State: <u>CA</u> Zip: <u>92649</u> Phone: <u>714-841-2323</u> Email:		<u>731797</u>	<u>32, 33, 34, 35</u>	<u>46000-</u>			

① As appropriate, Bidder shall identify Subcontractor as one of the following and shall include a valid proof of certification (except for OBE, SLBE and ELBE):

Certified Minority Business Enterprise	MBE	Certified Woman Business Enterprise	WBE
Certified Disadvantaged Business Enterprise	DBE	Certified Disabled Veteran Business Enterprise	DVBE
Other Business Enterprise	OBE	Certified Emerging Local Business Enterprise	ELBE
Certified Small Local Business Enterprise	SLBE	Small Disadvantaged Business	SDB
Woman-Owned Small Business	WoSB	HUBZone Business	HUBZone
Service-Disabled Veteran Owned Small Business	SDVOSB		

② As appropriate, Bidder shall indicate if Subcontractor is certified by:

City of San Diego	CITY	State of California Department of Transportation	CALTRANS
California Public Utilities Commission	CPUC	San Diego Regional Minority Supplier Diversity Council	SRMSDC
State of California's Department of General Services	CADoGS	City of Los Angeles	LA
State of California	CA	U.S. Small Business Administration	SBA

**The Bidder will not receive any subcontracting participation percentages if the Bidder fails to submit the required proof of certification.**

## BIDDING DOCUMENTS

### LIST OF SUBCONTRACTORS

In accordance with the requirements provided in the "Subletting and Subcontracting Fair Practices Act", Division 2, Part 1, Chapter 4 of the Public Contract Code, the Bidder shall list below the name and address of each Subcontractor who will perform work, labor, render services or specially fabricates and installs a portion [type] of the work or improvement, in an amount in excess of 0.5% of the Contractor's total Bid. The Bidder shall also list below the portion of the work which will be done by each subcontractor under this Contract. The Contractor shall list only one Subcontractor for each portion of the Work. The **DOLLAR VALUE** of the total Bid to be performed shall be stated for all subcontractors listed. Failure to comply with this requirement shall result in the Bid being rejected as **non-responsive** and ineligible for award. The Bidder's attention is directed to the Special Provisions - General; Paragraph 2-3 Subcontracts, which stipulates the percent of the Work to be performed with the Bidders' own forces. The Bidder shall list all SLBE, ELBE, DBE, DVBE, MBE, WBE, OBE, SDB, WoSB, HUBZone, and SDVOSB Subcontractors that Bidders are seeking recognition towards achieving any mandatory, voluntary, or both subcontracting participation percentages.

Subcontractors' License Number must be filled in. Failure to provide the information specified may deem the bidder **non-responsive**.

NAME, ADDRESS AND TELEPHONE NUMBER OF SUBCONTRACTOR	CONSTRUCTOR OR DESIGNER	SUBCONTRACTOR LICENSE NUMBER	TYPE OF WORK	DOLLAR VALUE OF SUBCONTRACT (MUST BE FILLED OUT)	MBE, WBE, DBE, DVBE, OBE, ELBE, SLBE, SDB, WoSB, HUBZone, OR SDVOSB	WHERE CERTIFIED	CHECK IF JOINT VENTURE PARTNERSHIP
Name: <del>Am Asphalt Co. Inc.</del> Address: <del>PO Box 310036</del> City: <del>Fontana</del> State: <del>CA</del> Zip: <del>92331</del> Phone: <del>909-427-8276</del> Email: _____		<del>7849601</del>	<del>SLBE SDB #26</del>				
Name: <u>ARROW PIPELINE</u> Address: <u>1330 PARK LINDALE DR</u> City: <u>VISTA</u> State: <u>CA</u> Zip: <u>92081</u> Phone: <u>760-476-9386</u> Email: _____		<u>811046</u>	<u>GENERAL LAT CONC. #2A</u>	<u>10800</u>	<u>SLBE SAN DIEGO</u>	<u>SD</u>	

① As appropriate, Bidder shall identify Subcontractor as one of the following and shall include a valid proof of certification (except for OBE, SLBE and ELBE):

Certified Minority Business Enterprise	MBE	Certified Woman Business Enterprise	WBE
Certified Disadvantaged Business Enterprise	DBE	Certified Disabled Veteran Business Enterprise	DVBE
Other Business Enterprise	OBE	Certified Emerging Local Business Enterprise	ELBE
Certified Small Local Business Enterprise	SLBE	Small Disadvantaged Business	SDB
Woman-Owned Small Business	WoSB	HUBZone Business	HUBZone
Service-Disabled Veteran Owned Small Business	SDVOSB		

② As appropriate, Bidder shall indicate if Subcontractor is certified by:

City of San Diego	CITY	State of California Department of Transportation	CALTRANS
California Public Utilities Commission	CPUC	San Diego Regional Minority Supplier Diversity Council	SRMSDC
State of California's Department of General Services	CADoGS	City of Los Angeles	LA
State of California	CA	U.S. Small Business Administration	SBA

**The Bidder will not receive any subcontracting participation percentages if the Bidder fails to submit the required proof of certification.**



## BIDDING DOCUMENTS

### LIST OF SUBCONTRACTORS

In accordance with the requirements provided in the "Subletting and Subcontracting Fair Practices Act", Division 2, Part 1, Chapter 4 of the Public Contract Code, the Bidder shall list below the name and address of each Subcontractor who will perform work, labor, render services or specially fabricates and installs a portion [type] of the work or improvement, in an amount in excess of 0.5% of the Contractor's total Bid. The Bidder shall also list below the portion of the work which will be done by each subcontractor under this Contract. The Contractor shall list only one Subcontractor for each portion of the Work. The **DOLLAR VALUE** of the total Bid to be performed shall be stated for all subcontractors listed. Failure to comply with this requirement shall result in the Bid being rejected as **non-responsive** and ineligible for award. The Bidder's attention is directed to the Special Provisions - General; Paragraph 2-3 Subcontracts, which stipulates the percent of the Work to be performed with the Bidders' own forces. The Bidder shall list all SLBE, ELBE, DBE, DVBE, MBE, WBE, OBE, SDB, WoSB, HUBZone, and SDVOSB Subcontractors that Bidders are seeking recognition towards achieving any mandatory, voluntary, or both subcontracting-participation percentages.

Subcontractors' License Number must be filled in. Failure to provide the information specified may deem the bidder **non-responsive**.

NAME, ADDRESS AND TELEPHONE NUMBER OF SUBCONTRACTOR	CONSTRUCTOR OR DESIGNER	SUBCONTRACTOR LICENSE NUMBER	TYPE OF WORK	DOLLAR VALUE OF SUBCONTRACT (MUST BE FILLED OUT)	MBE, WBE, DBE, DVBE, OBE, ELBE, SLBE, SDB, WoSB, HUBZone, OR SDVOSB	WHERE CERTIFIED	CHECK IF JOINT VENTURE PARTNERSHIP
Name: <u>SEALRIGHT PAVE</u> Address: <u>9053 OLIVE DR.</u> City: <u>SPRING VALLEY</u> State: <u>CA</u> Zip: <u>91977</u> Phone: <u>619-465-7990</u> Email:		<u>364113</u>	<u>#7,8,18,19,20</u> <u>25</u> <u>PAVE AC</u>	<u>17816-</u>	<u>SLBE,</u> <u>MBE</u>	<u>SD</u>	
Name: <u>PCI</u> Address: <u>3527 CITRUS CT</u> City: <u>LEMON GROVE</u> State: <u>CA</u> Zip: <u>91945</u> Phone: <u>619-466-4639</u> Email:		<u>680144</u>	<u>#9-13</u> <u>CONCRETE</u>	<u>11731-</u>			

① As appropriate, Bidder shall identify Subcontractor as one of the following and shall include a valid proof of certification (except for OBE, SLBE and ELBE):

Certified Minority Business Enterprise	MBE	Certified Woman Business Enterprise	WBE
Certified Disadvantaged Business Enterprise	DBE	Certified Disabled Veteran Business Enterprise	DVBE
Other Business Enterprise	OBE	Certified Emerging Local Business Enterprise	ELBE
Certified Small Local Business Enterprise	SLBE	Small Disadvantaged Business	SDB
Woman-Owned Small Business	WoSB	HUBZone Business	HUBZone
Service-Disabled Veteran Owned Small Business	SDVOSB		

② As appropriate, Bidder shall indicate if Subcontractor is certified by:

City of San Diego	CITY	State of California Department of Transportation	CALTRANS
California Public Utilities Commission	CPUC	San Diego Regional Minority Supplier Diversity Council	SRMSDC
State of California's Department of General Services	CADoGS	City of Los Angeles	LA
State of California	CA	U.S. Small Business Administration	SBA

**The Bidder will not receive any subcontracting participation percentages if the Bidder fails to submit the required proof of certification.**

**BIDDING DOCUMENTS**

**NAMED EQUIPMENT/MATERIAL SUPPLIER LIST**

The Bidder seeking the recognition of equipment, materials, or supplies obtained from Suppliers towards achieving any mandatory, voluntary, or both subcontracting participation percentages shall list the Supplier(s) on the Named Equipment/Material Supplier List. The Named Equipment/Material Supplier List, at a minimum, shall have the name, locations (City) and the **DOLLAR VALUE** of the Suppliers. The Bidder will be credited up to 60% of the amount to be paid to the Suppliers for such materials and supplies unless vendor manufactures or substantially alters materials and supplies in which case 100% will be credited. The Bidder is to indicate (Yes/No) whether listed firm is a supplier or manufacturer. In calculating the subcontractor participation percentages, vendors/suppliers will receive 60% credit of the listed **DOLLAR VALUE**, whereas manufacturers will receive 100% credit. If no indication provided, listed firm will be credited at 60% of the listed dollar value for purposes of calculating the Subcontractor Participation Percentage, Suppliers will receive 60% credit of the listed **DOLLAR VALUE**, whereas manufacturers will receive 100% credit. If no indication provided, listed firm will be credited at 60% of the listed **DOLLAR VALUE** for purposes of calculating the subcontractor participation percentages.

NAME, ADDRESS AND TELEPHONE NUMBER OF VENDOR/SUPPLIER	MATERIALS OR SUPPLIES	DOLLAR VALUE OF MATERIAL OR SUPPLIES (MUST BE FILLED OUT)	SUPPLIER (Yes/No)	MANUFACTURER (Yes/No)	MBE, WBE, DBE, DVBE, OBE, ELBE, SLBE, SDB, WoSB, HUBZone, OR SDVOSB	WHERE CERTIFIED
Name: <u>H D Supply</u> Address: <u>1560 W Linda Vista Dr</u> City: <u>San Marcos</u> State: <u>CA</u> Zip: <u>92078</u> Phone: <u>760-744 5606</u> Email:	Pipe materials	7,000.-	yes	NO	—	—
Name: <u>Mountain Materials</u> Address: <u>Tavern Rd</u> City: <u>Alpine</u> State: <u>CA</u> Zip: _____ Phone: _____ Email:	Rock	6500.-	yes	NO	SBE —	STATE OF CA

① As appropriate, Bidder shall identify Vendor/Supplier as one of the following and shall include a valid proof of certification (except for OBE,SLBE and ELBE):

- |   |        |  |         |
|---|--------|--|---------|
| Certified Minority Business Enterprise        | MBE    | Certified Woman Business Enterprise            | WBE     |
| Certified Disadvantaged Business Enterprise   | DBE    | Certified Disabled Veteran Business Enterprise | DVBE    |
| Other Business Enterprise                     | OBE    | Certified Emerging Local Business Enterprise   | ELBE    |
| Certified Small Local Business Enterprise     | SLBE   | Small Disadvantaged Business                   | SDB     |
| Woman-Owned Small Business                    | WoSB   | HUBZone Business                               | HUBZone |
| Service-Disabled Veteran Owned Small Business | SDVOSB |  |         |

② As appropriate, Bidder shall indicate if Vendor/Supplier is certified by:

- |  |        |  |          |
|--|--------|--|----------|
| City of San Diego                                    | CITY   | State of California Department of Transportation       | CALTRANS |
| California Public Utilities Commission               | CPUC   | San Diego Regional Minority Supplier Diversity Council | SRMSDC   |
| State of California's Department of General Services | CADoGS | City of Los Angeles                                    | LA       |
| State of California                                  | CA     | U.S. Small Business Administration                     | SBA      |

**The Bidder will not receive any subcontracting participation percentages if the Bidder fails to submit the required proof of certification.**

# BOUNDARY ST AND EDMONTON AVE SMR

## LEGEND

### CONTRACTOR'S RESPONSIBILITIES

- PURSUANT TO SECTION 4216 OF THE GOVERNMENT CODE, AT LEAST 2 WORKING DAYS PRIOR TO COMMENCING ANY EXCAVATION, YOU MUST CONTACT THE REGIONAL NOTIFICATION CENTER (E.G. UNDERGROUND SERVICE ALERT OF SOUTHERN CALIFORNIA) AND OBTAIN AN INQUIRY IDENTIFICATION NUMBER.
- NOTIFY SDG&E AT LEAST 10 WORKING DAYS PRIOR TO EXCAVATING WITHIN 10' OF SDG&E UNDERGROUND HIGH VOLTAGE TRANSMISSION POWER LINES. (I.E., 69 KV & HIGHER)
- LOCATE AND RECONNECT ALL SEWER LATERALS. LOCATIONS AS SHOWN ON THE PLANS ARE APPROXIMATE ONLY. LATERAL RECORDS ARE AVAILABLE TO THE CONTRACTOR AT THE WATER DEPARTMENT, 2797 CAMINITO CHOLLAS. LOCATE THE IMPROVEMENTS THAT WILL BE AFFECTED BY LATERAL REPLACEMENTS.
- THE LOCATIONS OF EXISTING BUILDINGS AS SHOWN ON THE PLAN ARE APPROXIMATE.
- KEEP STORM DRAIN INLETS FUNCTIONAL AT ALL TIMES DURING CONSTRUCTION.
- UNLESS OTHERWISE NOTED AS PREVIOUSLY POTHOLED (PH), ELEVATIONS SHOWN ON THE PROFILE FOR EXISTING UTILITIES ARE BASED ON A SEARCH OF THE AVAILABLE RECORD INFORMATION ONLY AND ARE SOLELY FOR THE CONTRACTOR'S CONVENIENCE. THE CITY DOES NOT GUARANTEE THAT IT HAS REVIEWED ALL AVAILABLE DATA. THE CONTRACTOR SHALL POTHOLE ALL EXISTING UTILITIES EITHER SHOWN ON THE PLANS OR MARKED IN THE FIELD IN ACCORDANCE WITH THE SPECIFICATIONS SECTION 5-1.
- EXISTING UTILITY CROSSING AS SHOWN ON THE PLANS ARE APPROXIMATE AND ARE NOT REPRESENTATIVE OF ACTUAL LENGTH AND LOCATION OF CONFLICT AREAS. SEE PLAN VIEW.

### LIMITS OF WORK

SHEET NO.	DISCIPLINE CODE	TITLE	LIMITS	PIPE		LENGTH (FT)
				SIZE (IN)	MATERIAL	
1	G-1	COVER SHEET				
2	C-1	S. 41ST STREET	NATIONAL AVE TO LOGAN AVE	10	SEWER	186.00
3	C-2	SAN MIGUEL AVENUE	S/O HEMLOCK STREET	10	REHAB	166.88
3	C-2	SAN MIGUEL TERRACE CANYON	S/O HEMLOCK STREET	8	SEWER	215.00
4	C-3	UNIVERSITY CITY H.S.	E/O GENESSEE AVE	8	SEWER	342.01
4	C-3	UNIVERSITY CITY H.S.	E/O GENESSEE AVE	8	REHAB	300.17
5	C-4	REPLUMB DETAILS		TOTAL SEWER		1210.06
6	C-5	STREET RESURFACING / SEWER ABANDONMENT				
7	C-6	CURB RAMP LOCATION / SIDEWALK AND DRIVEWAY IMPROVEMENT DETAILS				

### DISCIPLINE CODE

- G GENERAL
- C CIVIL

### WORK TO BE DONE

CONSTRUCTION OF BOUNDARY ST AND EDMONTON AVE SMR CONSISTS OF THE REPLACEMENT OF APPROXIMATELY 743 LINEAR FEET OF EXISTING VC SEWER MAINS WITH NEW PVC SEWER MAINS AND THE REHABILITATION OF APPROXIMATELY 467 LINEAR FEET OF EXISTING VC SEWER MAINS, INCLUDING REPLACEMENT AND REHABILITATED MANHOLES, RESURFACING, CURB RAMPS, REPLUMBS, AND OTHER WORK AND APPURTENANCES INCLUDED IN THESE SPECIFICATIONS AND DRAWINGS NUMBERED 37679-01-D THROUGH 37679-07-D

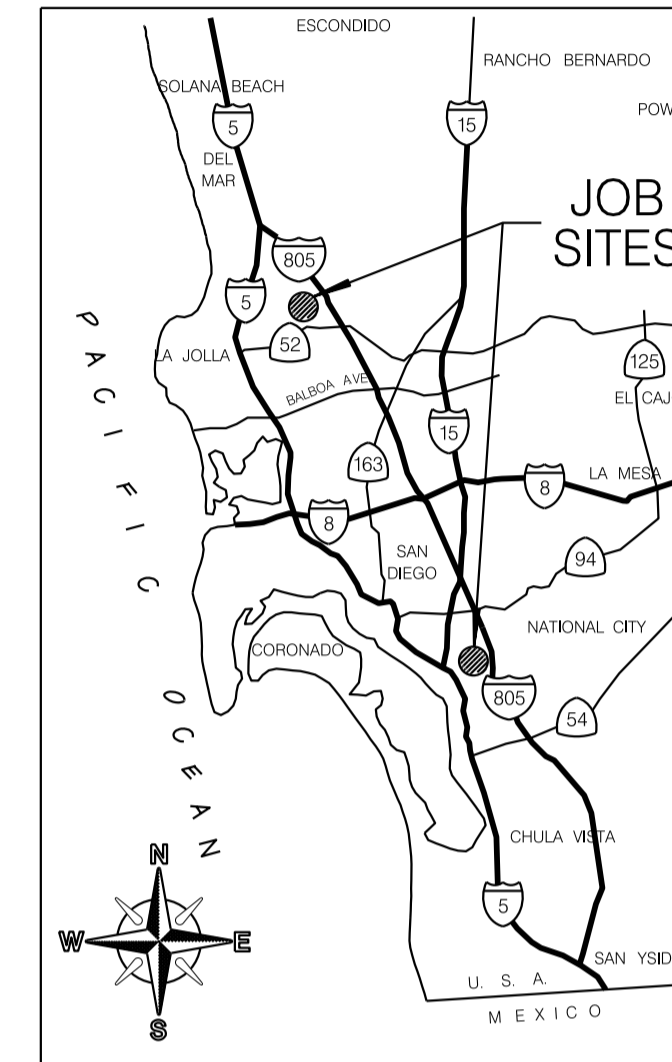

### VICINITY MAP

NOT TO SCALE

### IMPROVEMENTS

- TRENCH RESURFACING
- SEWER MAIN
- SEWER MANHOLE/PVC LINED
- REHAB. EX. SEWER MANHOLE
- SEWER MAIN REHAB.
- 4" SEWER LATERAL WITH C.O. UNLESS OTHERWISE SPECIFIED
- REPLUMB SEWER LATERAL WITH C.O.
- SEWER LATERAL CONNECTION
- TUNNEL SEWER REPLUMB LATERAL WITH C.O.
- SERVICE LATERAL CONNECTION TO REHABILITATED SEWER
- PIPE SUPPORT FOR UNDERCUT AC WATER MAIN
- ABANDON EX MANHOLE
- SLURRY FILL ABANDONED SEWER MAIN
- SURVEY MONUMENT

### REFERENCE

- SDG-107, SDG-108
- SDS-101, SDS-110 (TYPE C)
- SDS-106, SDS-107, SDS-108, SDM-113, SDS-120, M-3, SM-07
- SEE PLANS & SPECS
- SEE PLANS & SPECS
- SDS-102, SDS-103, SDS-104, SDS-105, SDS-110 (TYPE C), SDS-118
- SDS-102, SDS-103, SDS-104, SDS-105, SDS-110 (TYPE C), SDS-118
- SEE PLANS & SPECS
- SDS-101, SDS-103, SDS-104, SDS-105
- SEE PLANS & SPECS
- SEE PLANS & SPECS
- SDW-162
- SM-08
- SEE PLANS & SPECS
- M-10

### SYMBOL

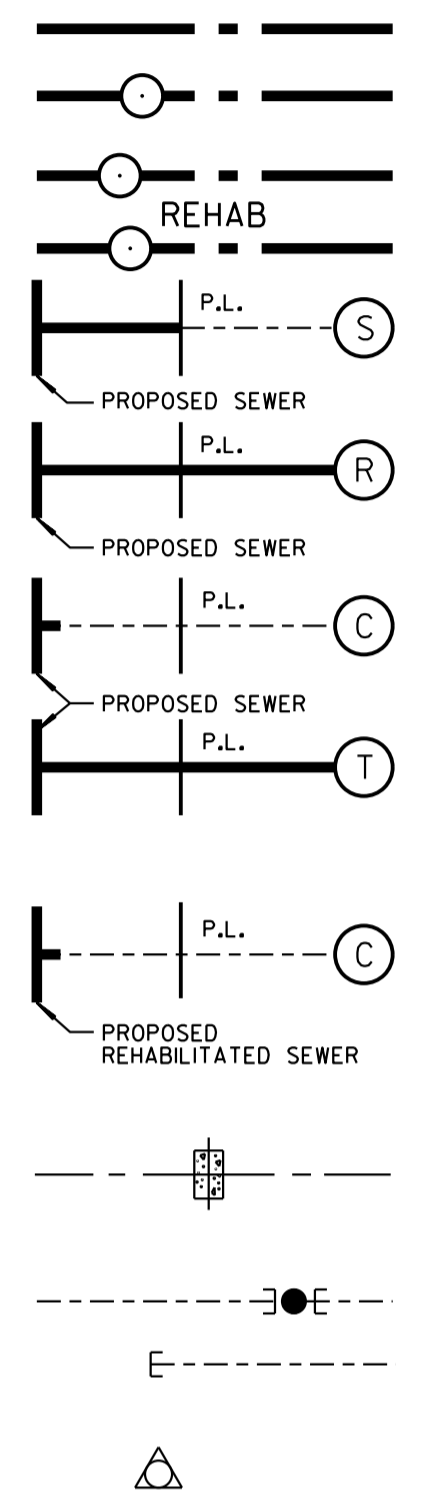

### STORM WATER PROTECTION

- THIS PROJECT IS SUBJECT TO MUNICIPAL STORM WATER PERMIT ORDER NO. R9-2007-0001 AND WPCP.

### ABBREVIATIONS

ABAND	ABANDON	EL, ELEV	ELEVATION	OVHD	OVER HEAD
ABAND'D	ABANDONED	ELEC	ELECTRIC	PVC	POLYVINYL CHLORIDE
AC	ASBESTOS CEMENT PIPE	EX, EXIST	EXISTING	PROP	PROPOSED
AHD	AHEAD	E/O	EAST OF	RED	REDUCER
ASSY	ASSEMBLY	ESMT	EASEMENT	RT	RIGHT
BFV	BUTTERFLY VALVE	F	FLANGE	S	SURVEY LINE
BK	BACK	FH	FIRE HYDRANT	SMR	SEWER MAIN REPLACEMENT
BTWN	BETWEEN	FS	FIRE SERVICE	SO	STUB OUT
CATV	CABLE TV	GV	GATE VALVE	S/O	SOUTH OF
CI	CAST IRON PIPE	HDPE	HIGH-DENSITY POLYETHYLENE	SWR	SEWER
C	CENTER LINE	HP	HIGH PRESSURE	TEL	TELEPHONE
COND	CONDUIT	IE	INVERT ELEVATION	UNK	UNKNOWN
CONT	CONTINUED	LT	LEFT	VC	VITRIFIED CLAY PIPE
CONTR	CONTRACTOR	MJ	MECHANICAL JOINT	WM	WATER METER
DB	DIRECT BURIED	MTD	MULTIPLE TELEPHONE DUCT	WTR	WATER
EB	ENCASED BURIED	N/O	NORTH OF	W/O	WEST OF

### EXISTING STRUCTURES

EX WATER MAIN & VALVES	---
EX WATER METER	---
EX FIRE HYDRANT	○
EX SEWER MAIN & MANHOLES	---
EX DRAINS	---
EX PAVEMENT (PROFILE)	///
EX GROUND LINE (PROFILE)	///
EX TRAFFIC SIGNAL	⊗ TS
EX STREET LIGHT	⊕ SL
GAS MAIN	---
ELEC. COND., TEL. COND., CATV	---E---T---C---
RAILROAD, TROLLEY TRACKS	

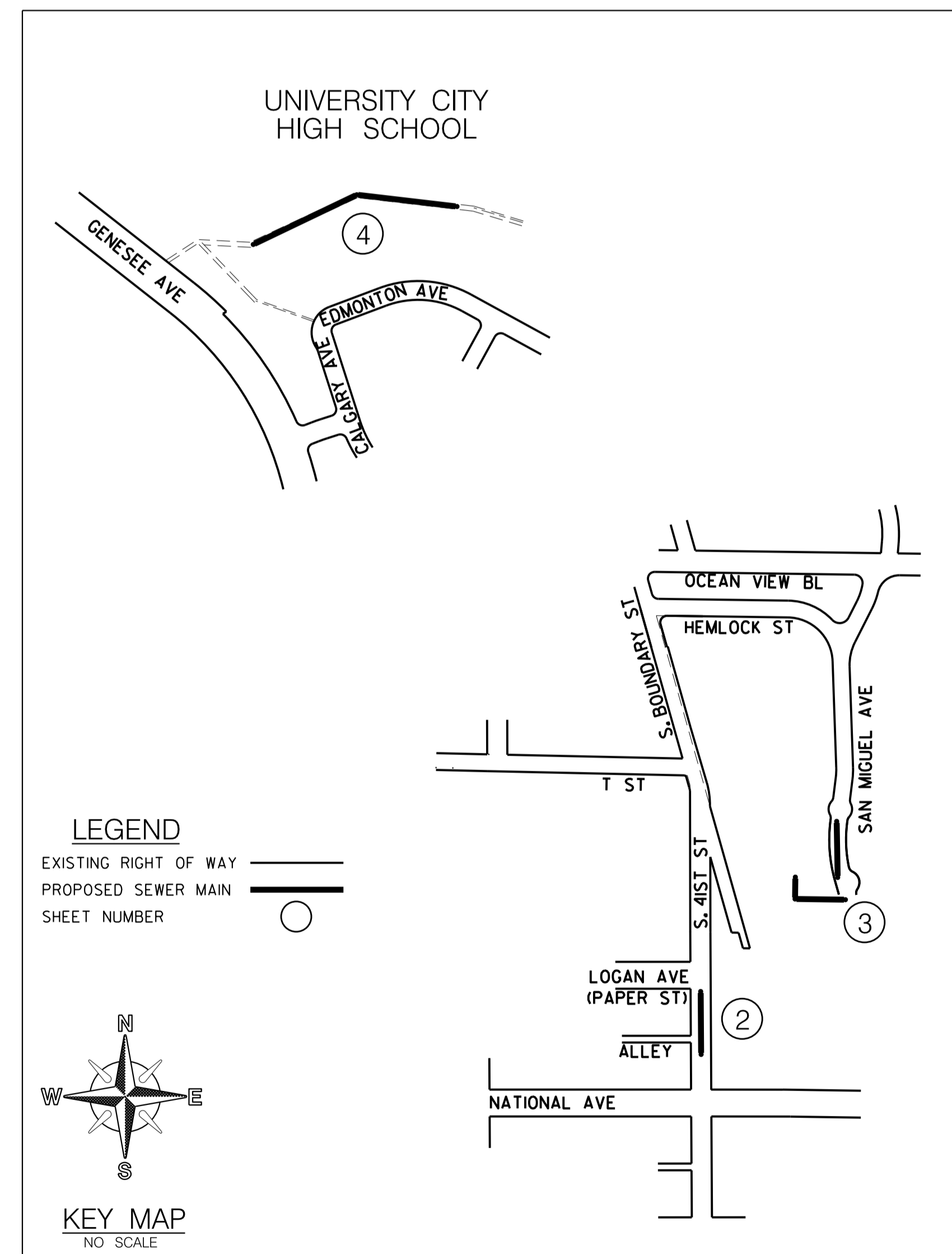

### FIELD DATA

BENCHMARK: SEBP (43.216) OCEAN VIEW BLVD/4  
 FIELD NOTES: BROOKS, 194-1734, SHT 3 OF 16, 04/18/2013  
 DATUM: MEAN SEA LEVEL  
 STREETS REQUIRING 12" TRENCH CAP:  
 NONE

AS-BUILT INFORMATION	
MATERIALS	MANUFACTURER
PIPE CL 235 (WATER)	-
PIPE SDR 35 (SEWER)	-
GATE VALVES	-
FIRE HYDRANTS	-
SEWER MANHOLES	-
REHABILITATE SEWER MANHOLES	-
REHABILITATE SEWER MAIN	-

DESCRIPTION	BY	APPROVED	DATE	FILMED
ORIGINAL	JG/RH			

PLANS FOR THE CONSTRUCTION OF BOUNDARY ST AND EDMONTON AVE SMR COVER SHEET	
CITY OF SAN DIEGO, CALIFORNIA PUBLIC WORKS DEPARTMENT SHEET 01 OF 07 SHEETS	WATER WBS N/A SEWER WBS B13173
DESIGNED BY: <i>Rania Sarkis</i> FOR CITY ENGINEER: <b>RANIA SARKIS AMEN</b> PRINT NAME:	DATE: 8/8/2014 PROJECT MANAGER: <b>JERICHO GALLARDO</b>
CHIEF ENGINEER: <b>JOSELITO GUINTO</b> PROJECT ENGINEER:	SEE SHEETS CCS27 COORDINATE
CONTRACTOR: _____	DATE STARTED: _____
INSPECTOR: _____	DATE COMPLETED: _____
37679-01-D	

CONSTRUCTION CHANGE / ADDENDUM			
CHANGE	DATE	AFFECTED OR ADDED SHEET NUMBERS	APPROVAL NO.

WARNING	
0	1
IF THIS BAR DOES NOT MEASURE 1" THEN DRAWING IS NOT TO SCALE.	

CITY OF SAN DIEGO  
PUBLIC WORKS PROJECT



BOUNDARY ST AND EDMONTON AVE SMR

G-1

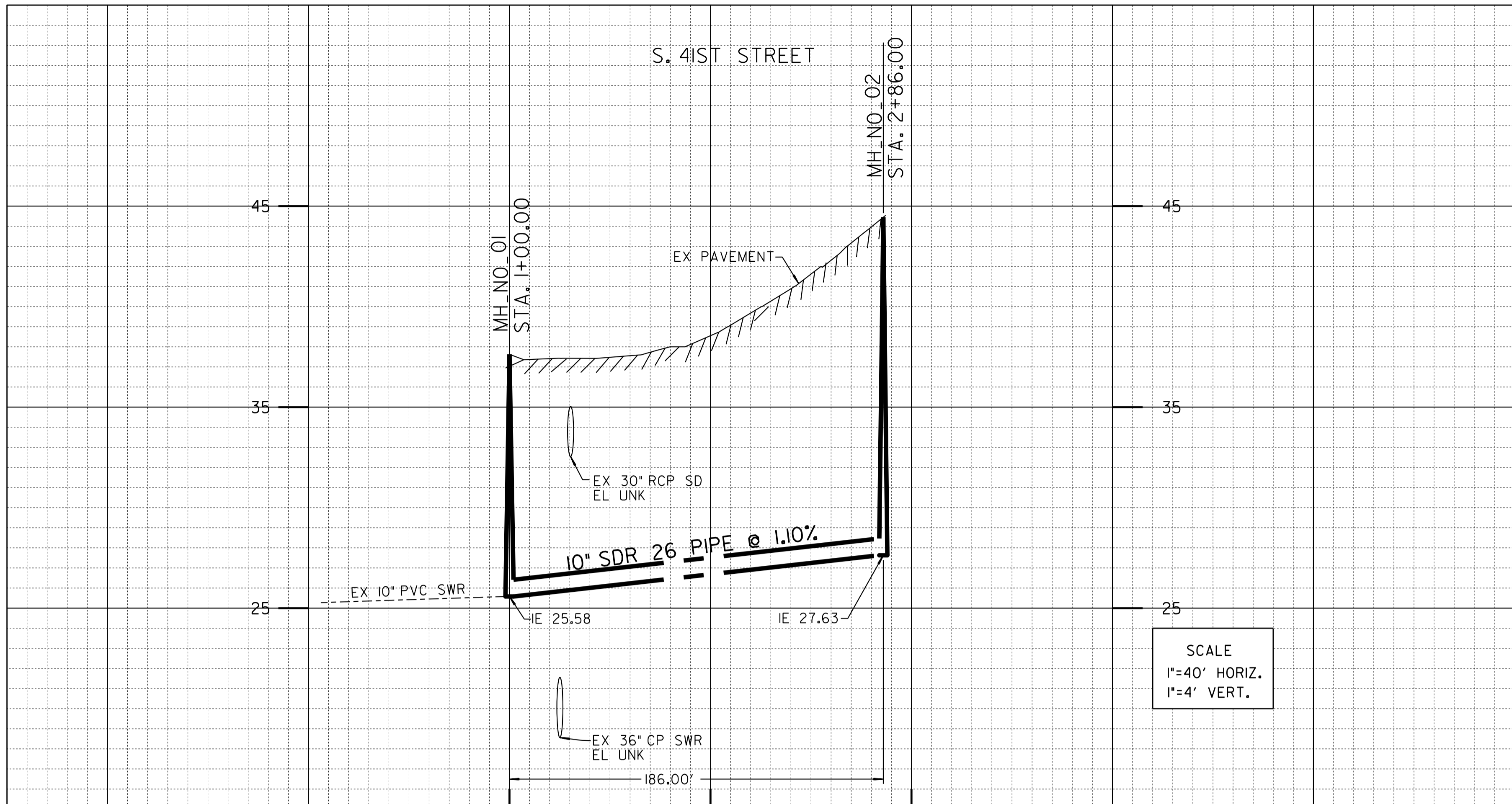

- NOTES:**
- SEWER LATERALS WITH PRIVATE REPLUMBING ARE SHOWN SCHEMATICALLY FOR BIDDING PURPOSES ONLY. THE ACTUAL LOCATION AND LENGTH OF EACH SEWER LATERAL SHALL BE DETERMINED IN THE FIELD AND IN ACCORDANCE WITH SECTION 306-1.8 OF THE SPECIFICATIONS. THE CONTRACTOR SHALL PERFORM ALL WORK NECESSARY TO CONNECT EXISTING HOUSE PLUMBING TO THE NEW SEWER LATERAL IN ACCORDANCE WITH THE SPECIFICATIONS, UNIFORM BUILDING CODE, AND UNIFORM PLUMBING CODE. ANY PRIVATE IMPROVEMENTS DAMAGED OR DISTURBED AS A RESULT OF THIS REPLUMBING WORK SHALL BE RESTORED BY THE CONTRACTOR TO ITS ORIGINAL CONDITION.
  - THE REPLUMBING WORK MAY REQUIRE HAND EXCAVATION.
  - BEFORE INSTALLING THE NEW SEWER MAIN FOR THE SEWER LATERAL REPLUMB, THE CONTRACTOR SHALL INVESTIGATE/POTHOLE EXISTING HOUSE PLUMBING TO ENSURE THE MINIMUM 2% SLOPE OF NEW SEWER LATERAL CAN BE ACHIEVED.

SCALE  
1"=40' HORIZ.  
1"=4' VERT.

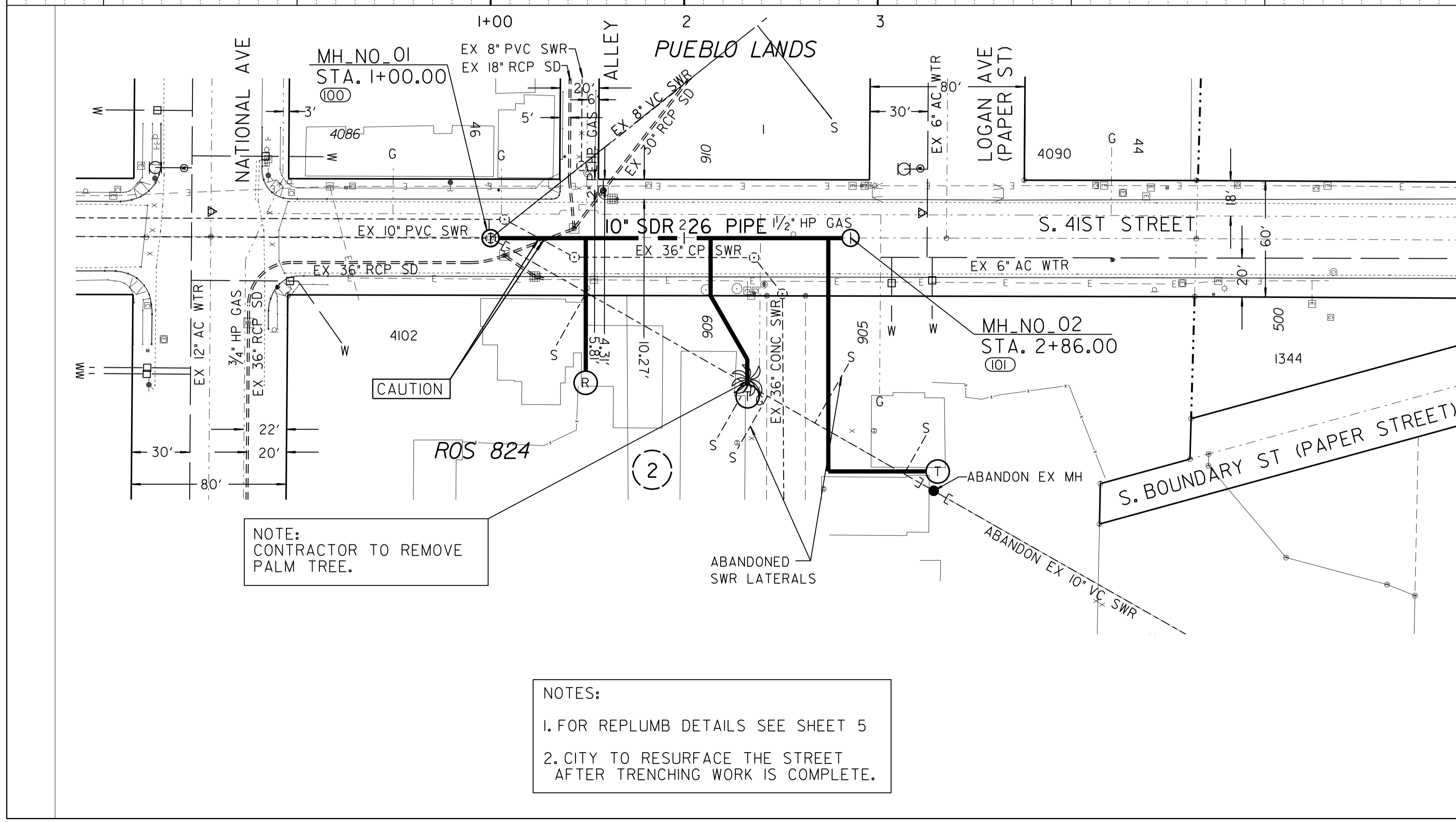

**HORIZONTAL ALIGNMENT DATA**

Alignment Name: Sheet 02  
Alignment Style: Default

Station	Northing	Easting
Element: Linear		
POB (100):	1+00.00	1834274.33 6298306.52
POE (101):	3+40.00	1834514.32 6298304.77
Tangential Direction:	6.28	
Tangential Length:	240.00	

**REFERENCE:**  
WATER: 6894-W, 7291-W, 20287-8-D  
SEWER: 328-D, 27600-9-D  
STORM DRAIN: 19818-D  
GAS: 16072-118690  
ELECTRIC: 16072-118690  
CABLE TV: 16072-118690  
TELEPHONE: ms705db  
IMPROVEMENTS: 19848-D  
100' SCALE/FIELD BOOK: 123S, 124S  
THOMAS BROS.: 1289-H5

**RETIREMENTS:**  
8" - CP - 263.49' - 1929  
8" - VC - 263.89' - 1939  
MH - 4X3 - 1 - 1900 - 1929  
4" LATERAL - 4 - VC - 1929

NOTE:  
CONTRACTOR TO REMOVE  
PALM TREE.

- NOTES:**
- FOR REPLUMB DETAILS SEE SHEET 5
  - CITY TO RESURFACE THE STREET AFTER TRENCHING WORK IS COMPLETE.

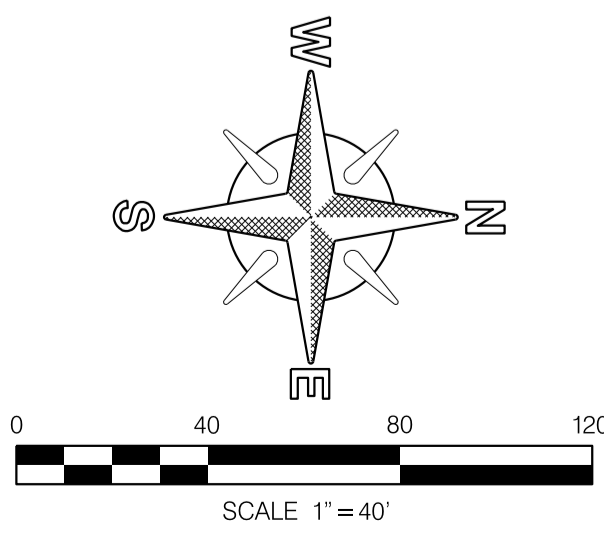

BOUNDARY ST AND EDMONTON AVE SMR S. 41ST STREET NATIONAL AVE TO LOGAN AVE			
CITY OF SAN DIEGO, CALIFORNIA PUBLIC WORKS DEPARTMENT SHEET 02 OF 07 SHEETS		WATER WBS: N/A SEWER WBS: B13173	
FOR CITY ENGINEER <i>Rania Sarkis Amen</i> PRINT NAME: RANIA AMEN	DATE: 8/8/2014	DESIGNED BY: JERICHO GALLARDO PROJECT MANAGER	
CHIEF OF ENGINEERING JOSELITO GUINTO PROJECT ENGINEER			
DESCRIPTION	BY	APPROVED	DATE FILMED
ORIGINAL	JG/RH		192-1735 CCS27 COORDINATE
			1832-6295 CCS83 COORDINATE
CONTRACTOR	DATE STARTED	37679-02-D	
INSPECTOR	DATE COMPLETED		

C-1

S. 41ST STREET

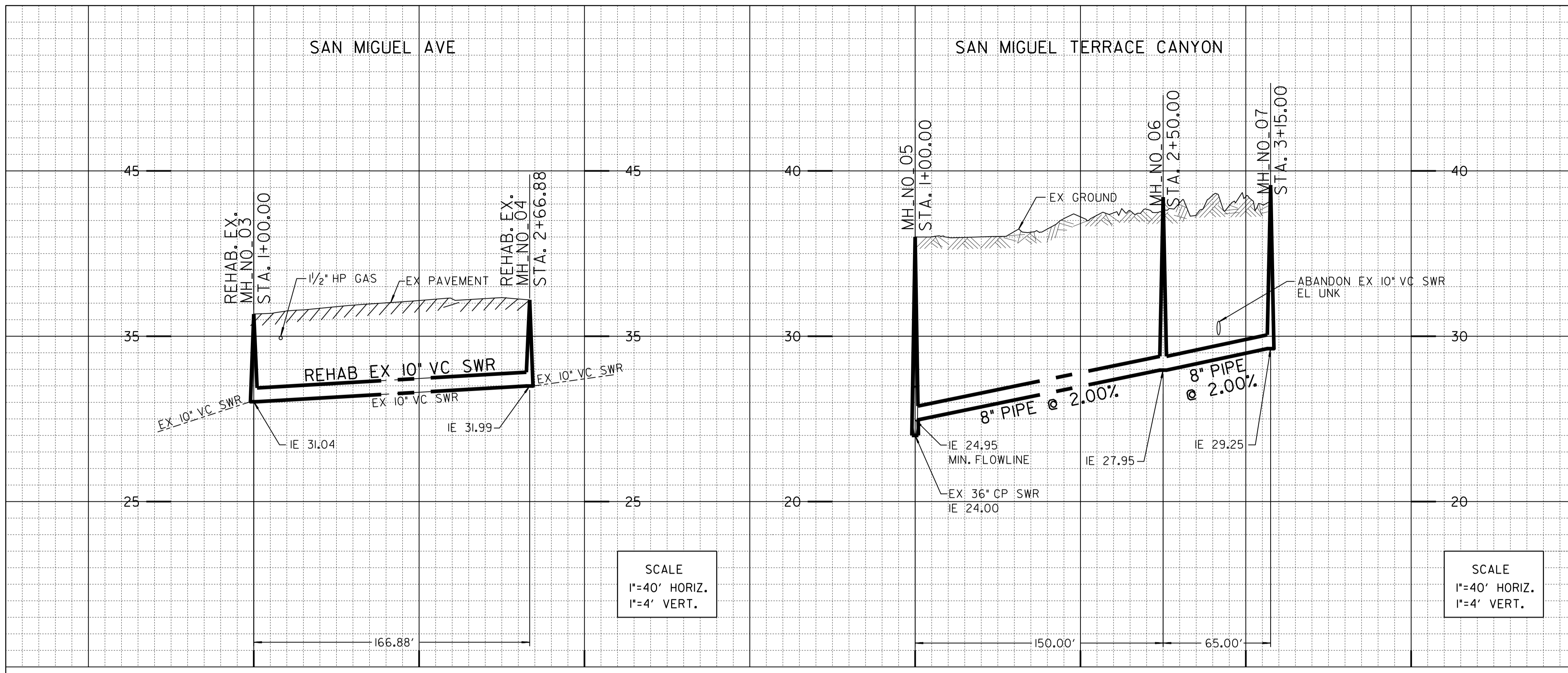

**NOTES:**

- SEWER LATERALS WITH PRIVATE REPLUMBING ARE SHOWN SCHEMATICALLY FOR BIDDING PURPOSES ONLY. THE ACTUAL LOCATION AND LENGTH OF EACH SEWER LATERAL SHALL BE DETERMINED IN THE FIELD AND IN ACCORDANCE WITH SECTION 306-L8 OF THE SPECIFICATIONS. THE CONTRACTOR SHALL PERFORM ALL WORK NECESSARY TO CONNECT EXISTING HOUSE PLUMBING TO THE NEW SEWER LATERAL IN ACCORDANCE WITH THE SPECIFICATIONS, UNIFORM BUILDING CODE, AND UNIFORM PLUMBING CODE. ANY PRIVATE IMPROVEMENTS DAMAGED OR DISTURBED AS A RESULT OF THIS REPLUMBING WORK SHALL BE RESTORED BY THE CONTRACTOR TO ITS ORIGINAL CONDITION.
- THE REPLUMBING WORK MAY REQUIRE HAND EXCAVATION.
- BEFORE INSTALLING THE NEW SEWER MAIN FOR THE SEWER LATERAL REPLUMB, THE CONTRACTOR SHALL INVESTIGATE/POTHOLE EXISTING HOUSE PLUMBING TO ENSURE THE MINIMUM 2% SLOPE OF NEW SEWER LATERAL CAN BE ACHIEVED.

SCALE  
1"=40' HORIZ.  
1"=4' VERT.

SCALE  
1"=40' HORIZ.  
1"=4' VERT.

**HORIZONTAL ALIGNMENT DATA**

Alignment Name: Sheet 03  
Alignment Style: Default

Station	Northing	Easting
Element: Linear		
POB (102): 1+00.00	1834800.92	6298713.00
POE (103): 2+66.88	1834967.77	6298709.95
Tangential Direction:	6.26	
Tangential Length:	166.88	

Alignment Name: Sheet 03  
Alignment Style: Default

Station	Northing	Easting
Element: Linear		
PI (104): 1+00.00	1834734.78	6298736.03
PI (105): 2+50.00	1834736.86	6298586.05
Tangential Direction:	4.73	
Tangential Length:	150.00	

Element: Linear  
PI (106): 2+50.00 1834736.86 6298586.05  
POE (106): 3+15.00 1834801.86 6298586.95  
Tangential Direction: 0.01  
Tangential Length: 65.00

**REFERENCE:**

WATER: 7929-L, 12340-2-D  
SEWER: 7929-L, 26285-II, -12-D  
STORM DRAIN: 19848-D  
GAS: 16072-118690  
ELECTRIC: 16072-118690  
CABLE TV: 16072-118690  
TELEPHONE: ms0505ac  
IMPROVEMENTS: 7926-L, 17254-16-D, 26362-4-D, 38046-B  
100' SCALE/FIELD BOOK: J235  
THOMAS BROS.: 1289-H5

**RETIREMENTS:**

10" - VC - 348' - 1950  
MH - 4X3 - 3 - 1950  
4" LATERAL - 10 - VC - 1950

**CONTRACTOR'S NOTE:**  
USE EXTREME CAUTION WHEN WORKING DUE TO LOW OVERHEAD UTILITY LINES.

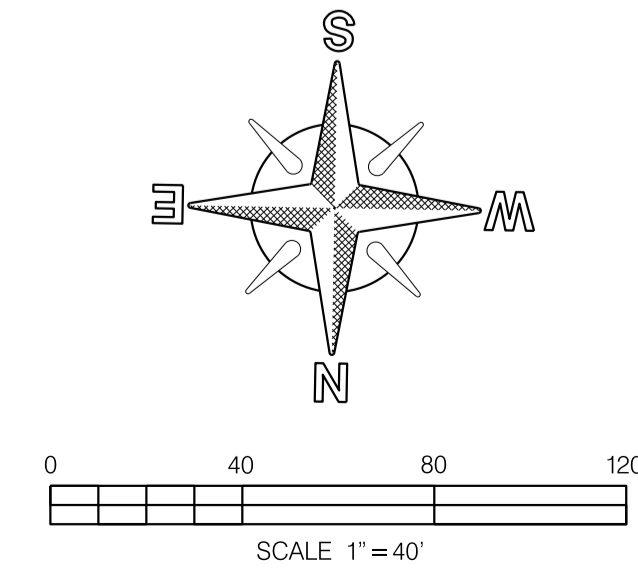
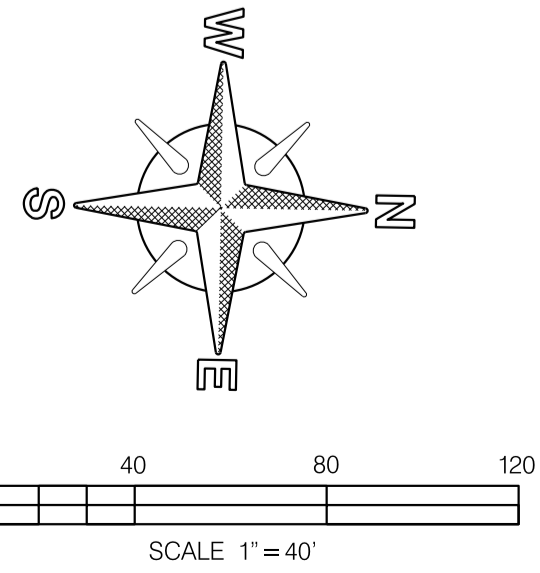
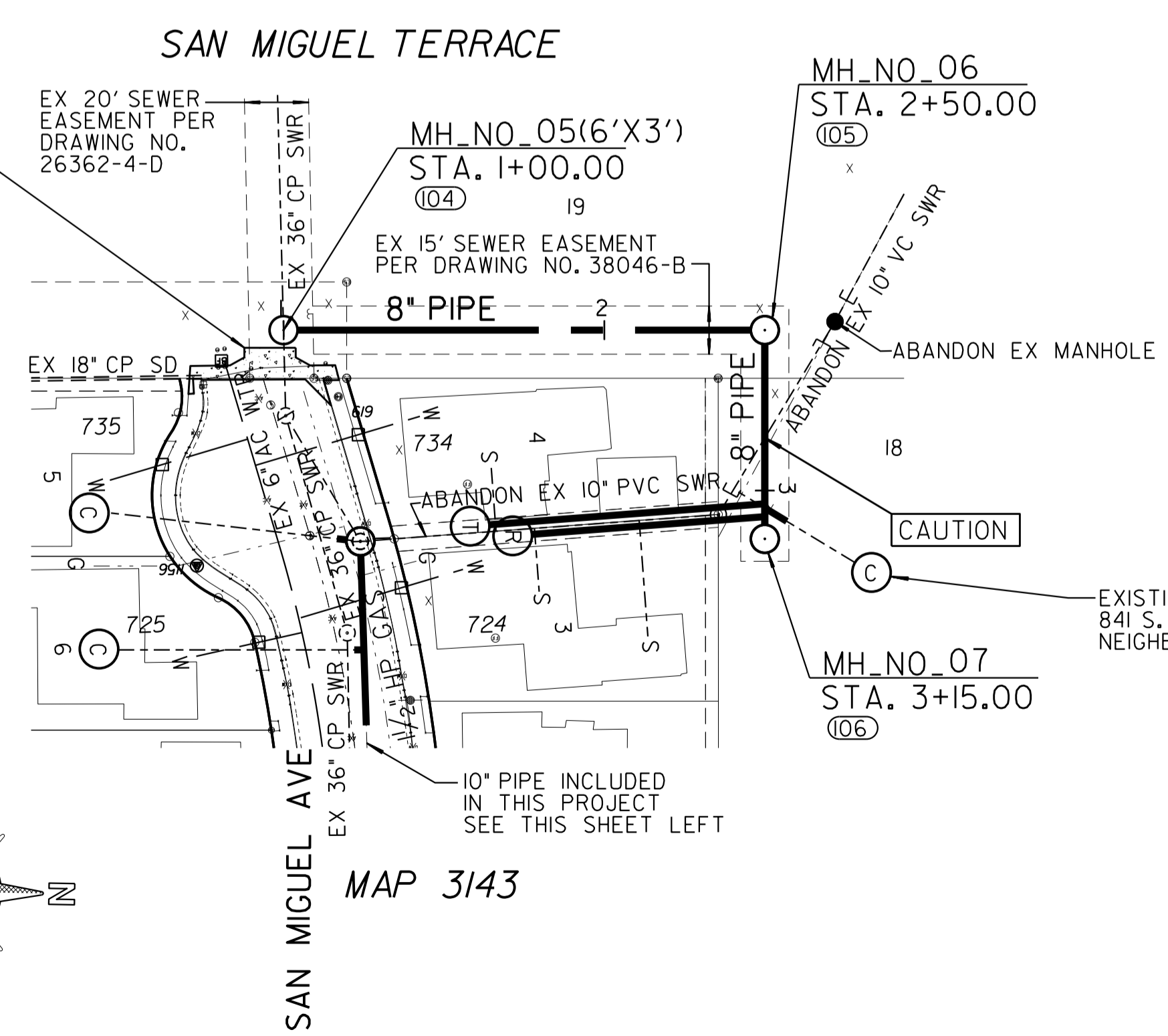
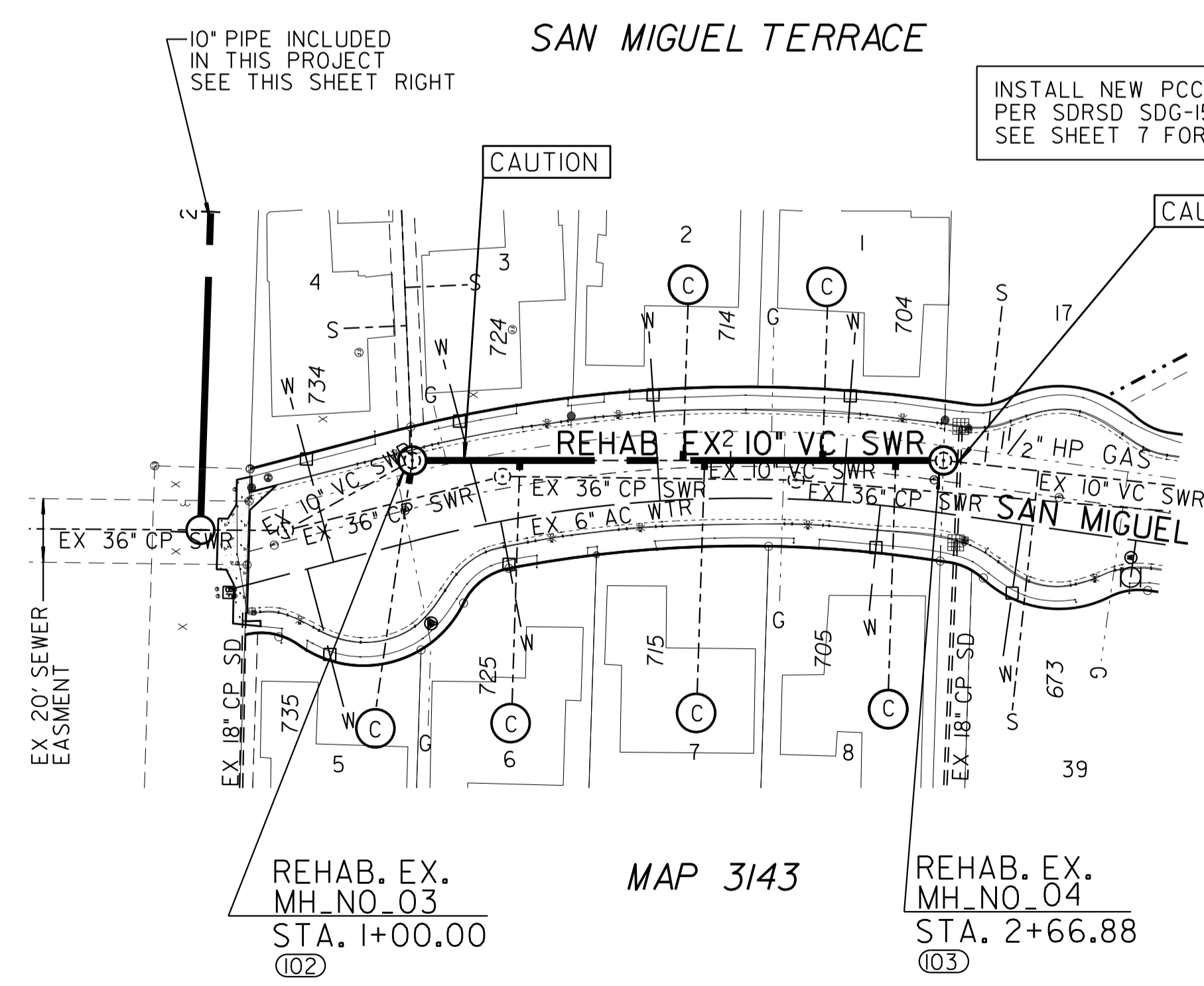

BOUNDARY ST AND EDMONTON AVE SMR  
SAN MIGUEL AVE /  
SAN MIGUEL TERRACE CANYON  
SO HEMLOCK STREET

CITY OF SAN DIEGO, CALIFORNIA PUBLIC WORKS DEPARTMENT SHEET 03 OF 07 SHEETS		WATER WBS: N/A SEWER WBS: B13173
FOR CITY ENGINEER <i>Rania Sarkis Amen</i> RANIA AMEN PROJECT MANAGER	8/8/2014 DATE	JERICHO GALLARDO PROJECT MANAGER
DESCRIPTION	BY	APPROVED
ORIGINAL	JG/RH	
194-1737 CCS27 COORDINATE		1834-6297 CCS83 COORDINATE
CONTRACTOR		DATE STARTED
INSPECTOR		DATE COMPLETED
		37679-03-D



C-2

UNIVERSITY CITY HIGH SCHOOL

REHAB. EX.  
MH\_NO\_10  
STA. 7+42.18

260

250

240

260

250

240

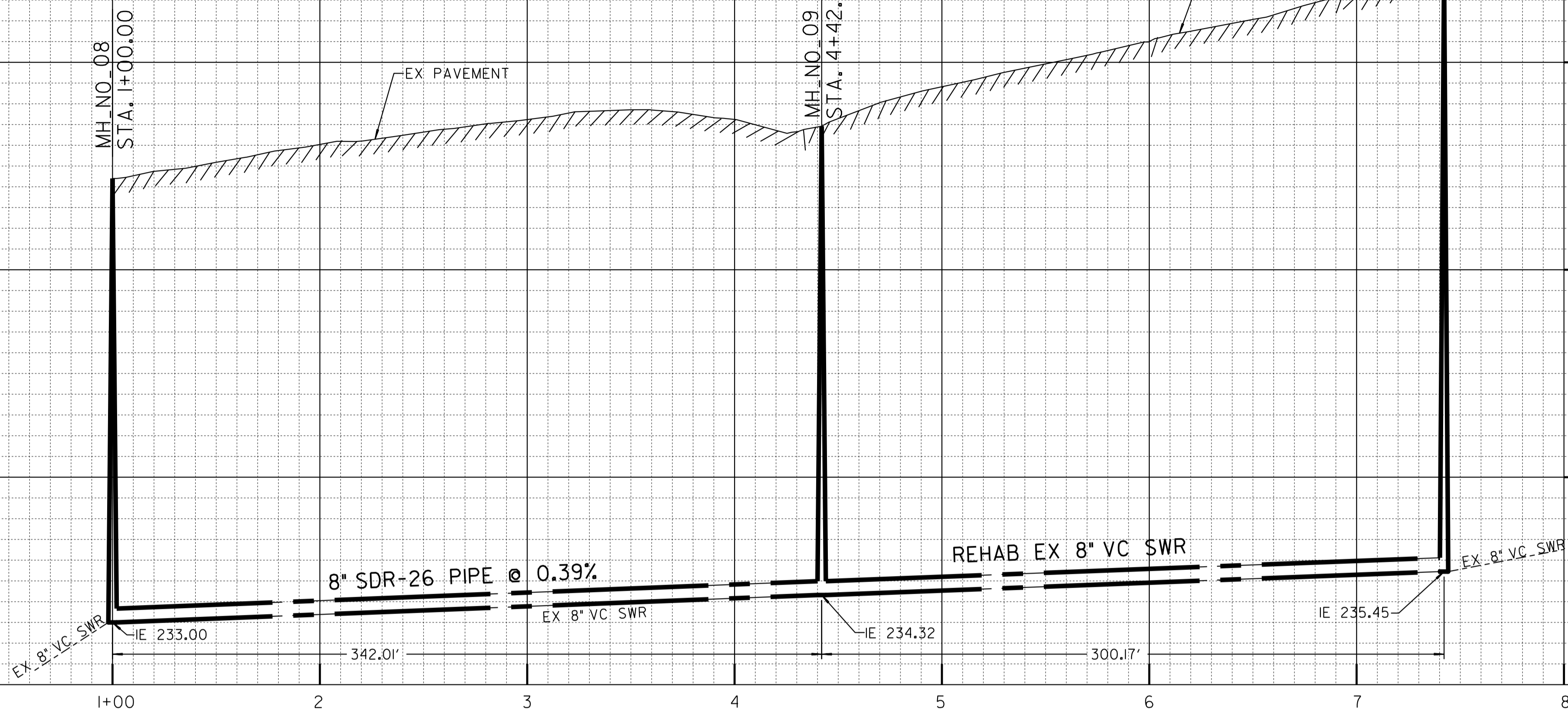

SCALE  
1"=40' HORIZ.  
1"=4' VERT.

GENESSEE AVE

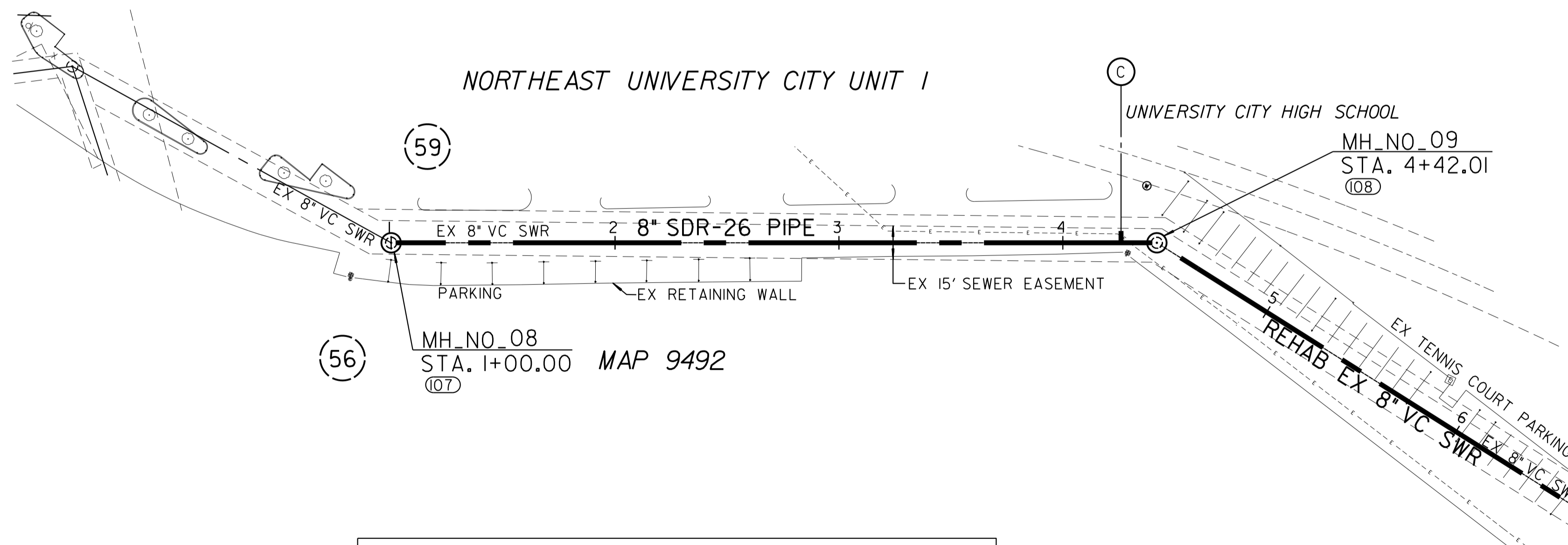

HORIZONTAL ALIGNMENT DATA

Alignment Name: Sheet 04  
Alignment Style: Default

Station Northing Easting

Element: Linear  
POB (I07): 1+00.00 1893897.77 6268109.01  
PI (I08): 4+42.01 1894045.59 6268417.43  
Tangential Direction: L12  
Tangential Length: 342.01

Element: Linear  
PI (I08): 4+42.01 1894045.59 6268417.43  
POE (I09): 7+42.18 1894010.69 6268715.56  
Tangential Direction: L69  
Tangential Length: 300.17

REFERENCE:

WATER: I1897-16-D  
SEWER: I3700-8-D, 21989-3-D  
STORM DRAIN: NONE  
GAS: I6072-I18690  
ELECTRIC: I6072-I18690  
CABLE TV: I6072-I18690  
TELEPHONE: msl232db  
IMPROVEMENTS: NONE  
100' SCALE/FIELD BOOK: D09S, E09S  
THOMAS BROS.: I228-E4

RETIREMENTS:

8" - VC - 642' - 1971  
MH - 4X3 - 3 - 1971

CONTRACTOR'S NOTES:

- CONTRACTOR SHALL COORDINATE ACCESS TO UNIVERSITY CITY HIGH SCHOOL BY CONTACTING PRINCIPAL JEFF OLIVARES AT (858) 457-3040.
- CONTRACTOR SHALL PROTECT/RELOCATE ELECTRIC CONDUIT AS NECESSARY DURING CONSTRUCTION. SERVICE TO BE MAINTAINED AT ALL TIMES.

REHAB. EX.  
MH\_NO\_10  
STA. 7+42.18  
(I09)

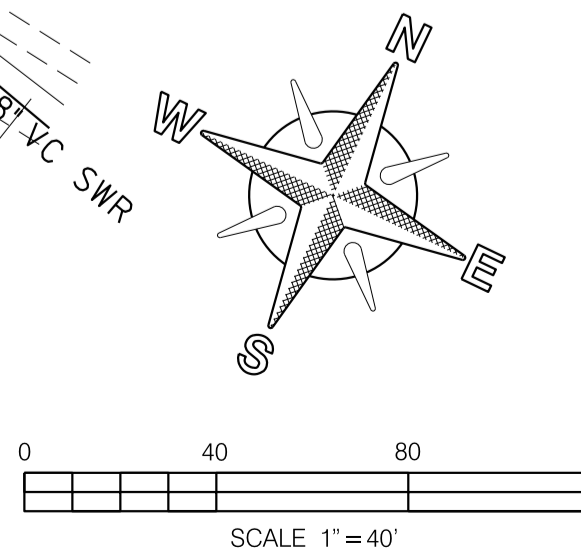

C-3

BOUNDARY ST AND EDMONTON AVE SMR  
UNIVERSITY CITY HIGH SCHOOL  
E/O GENESSEE AVE

CITY OF SAN DIEGO, CALIFORNIA PUBLIC WORKS DEPARTMENT SHEET 04 OF 07 SHEETS		WATER WBS: N/A	SEWER WBS: B13173
FOR CITY ENGINEER RANIA AMEN PRINT NAME		DATE 8/8/2014	PROJECT MANAGER JERICHO GALLARDO
DESCRIPTION	BY	APPROVED	DATE
ORIGINAL	JG/RH		
PROJECT ENGINEER JOSELITO GUINTO			252-1705 CCS27 COORDINATE
1892-6265 CCS83 COORDINATE			37679-04-D
CONTRACTOR		DATE STARTED	
INSPECTOR		DATE COMPLETED	

UNIVERSITY CITY HIGH SCHOOL

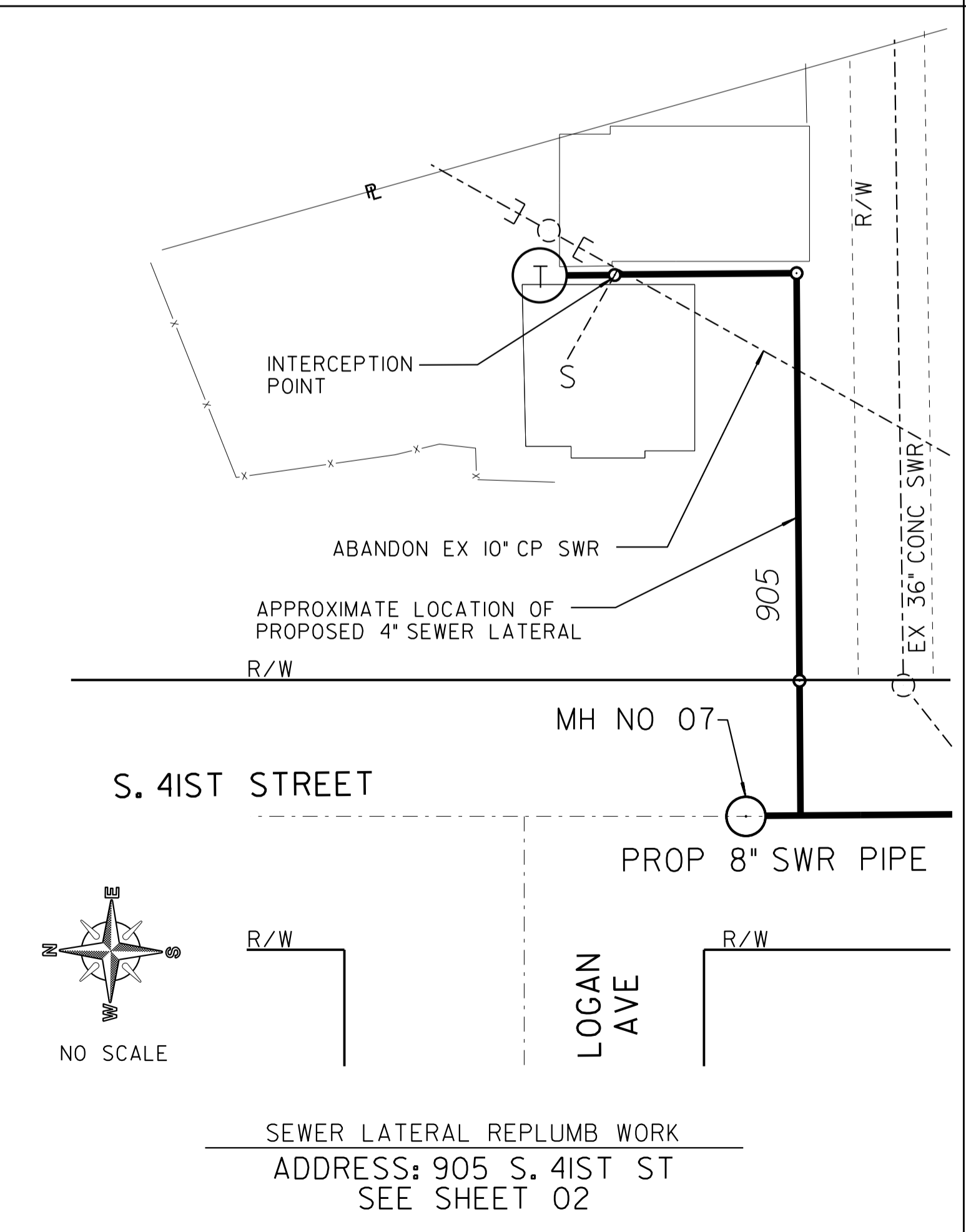
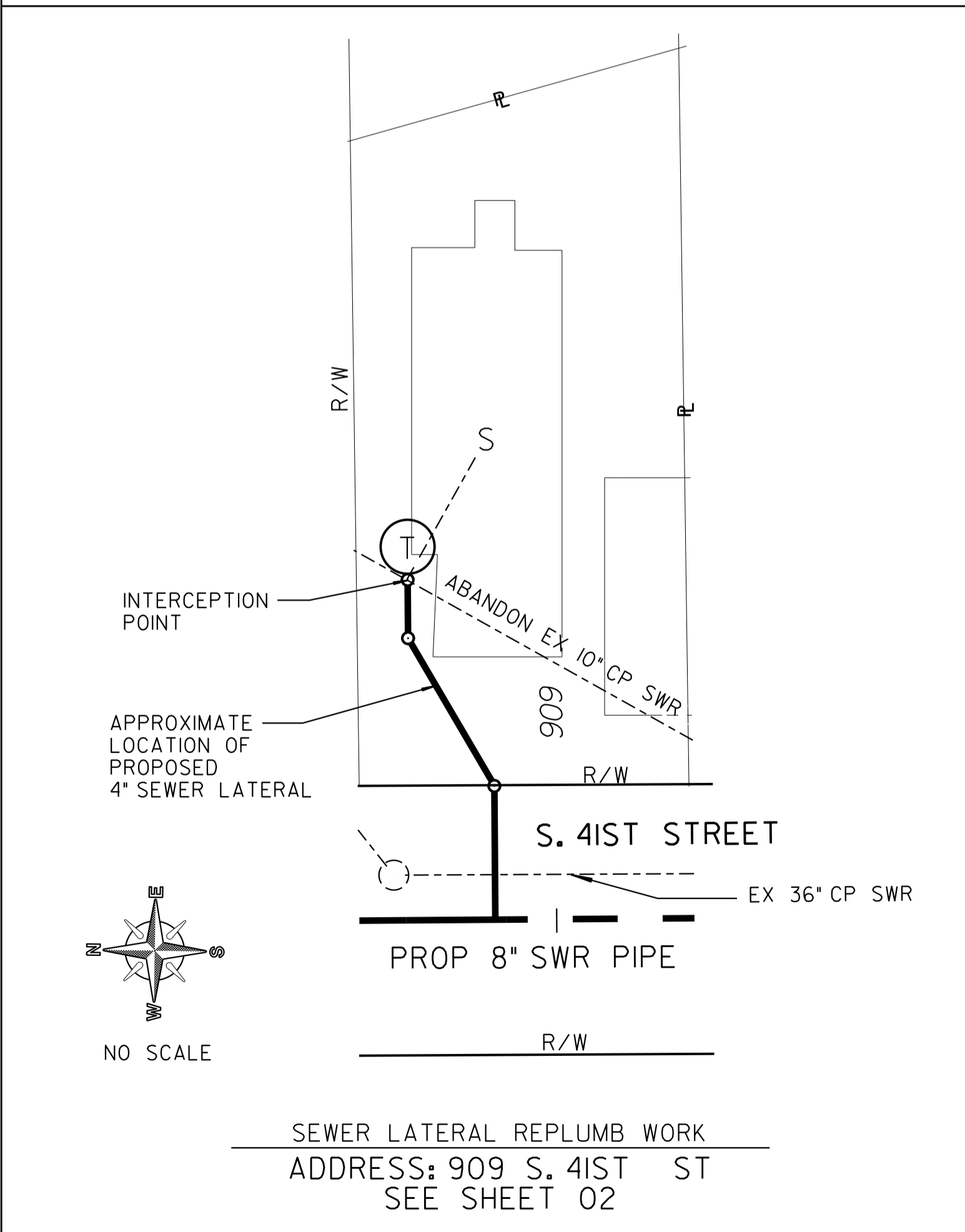
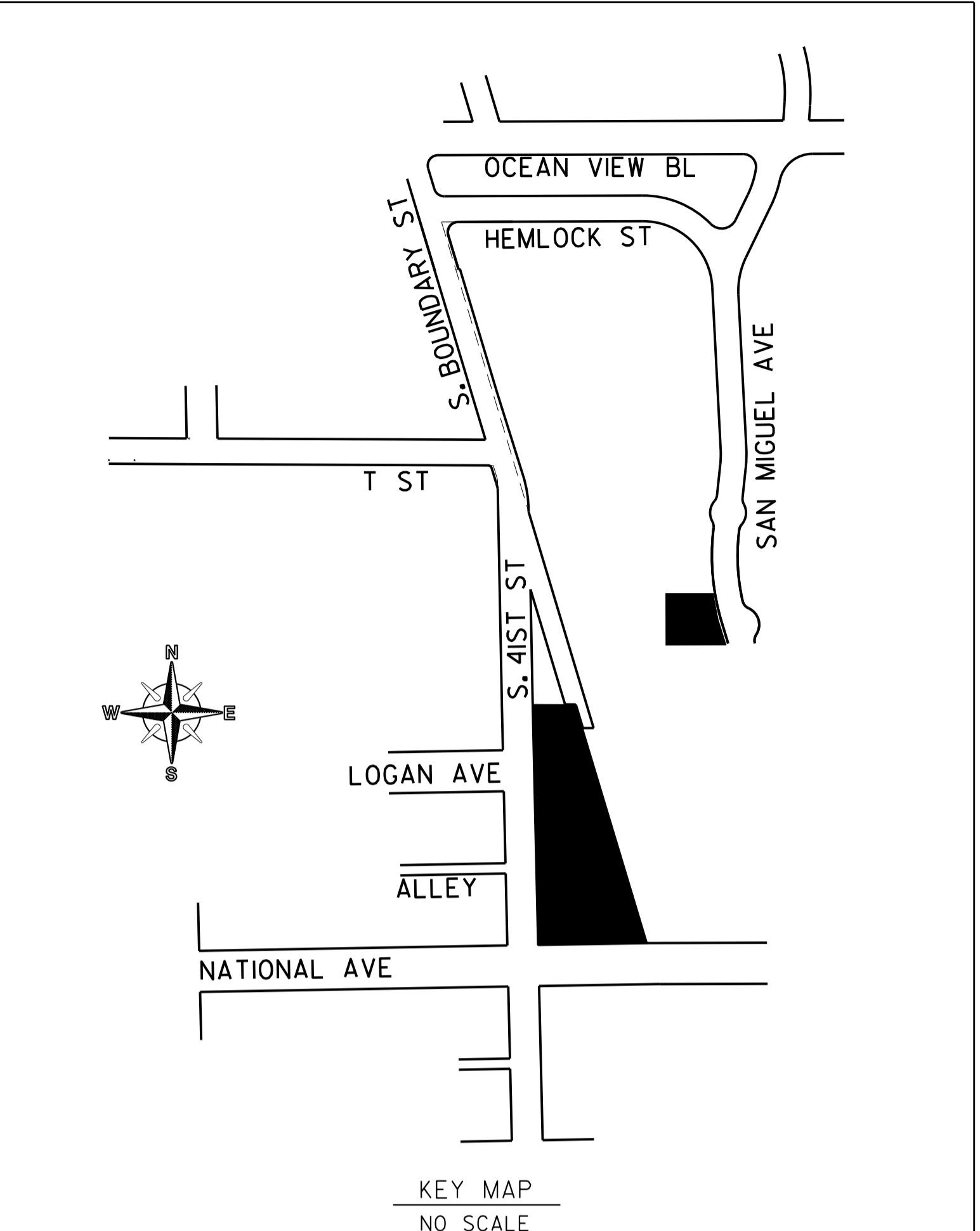
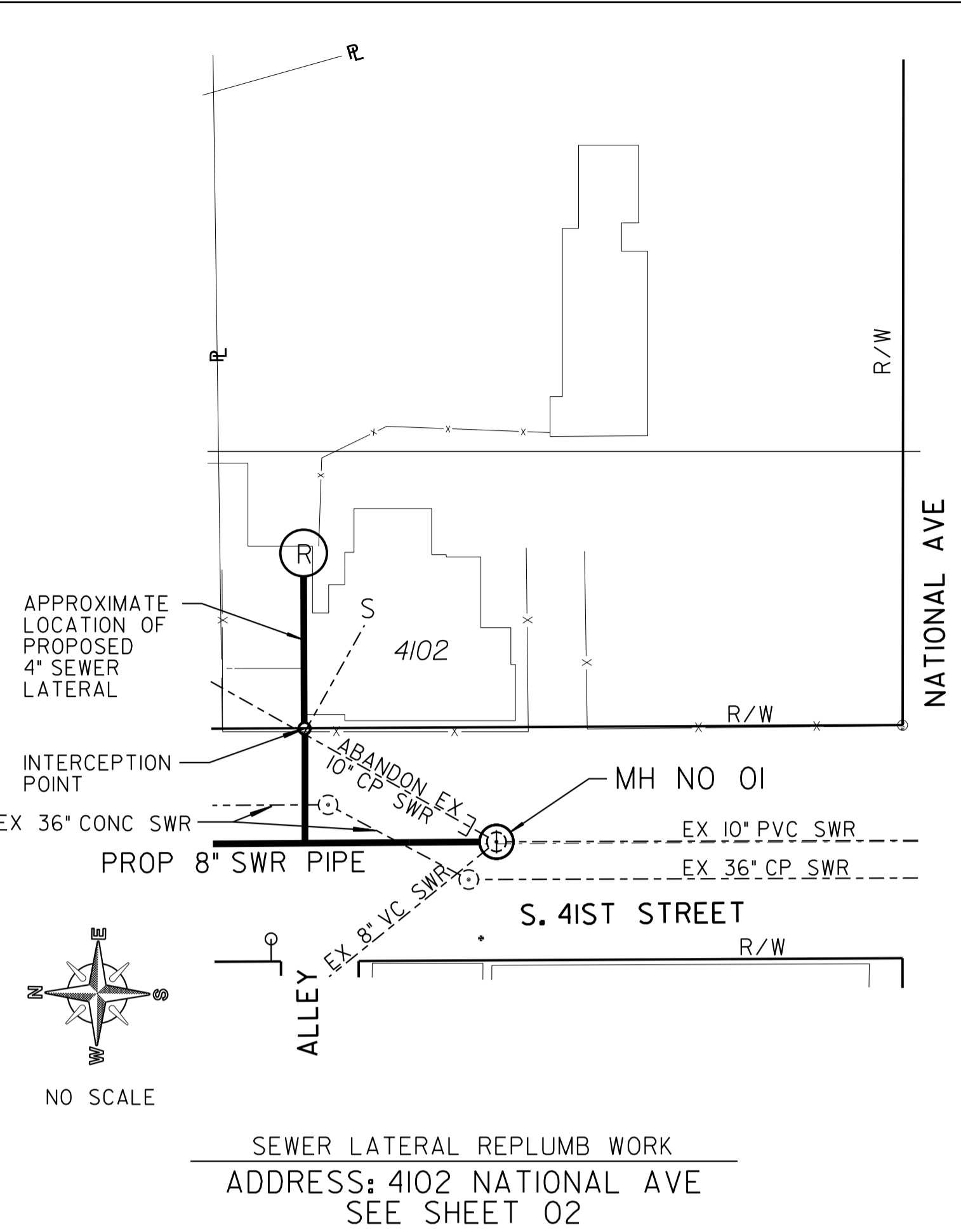
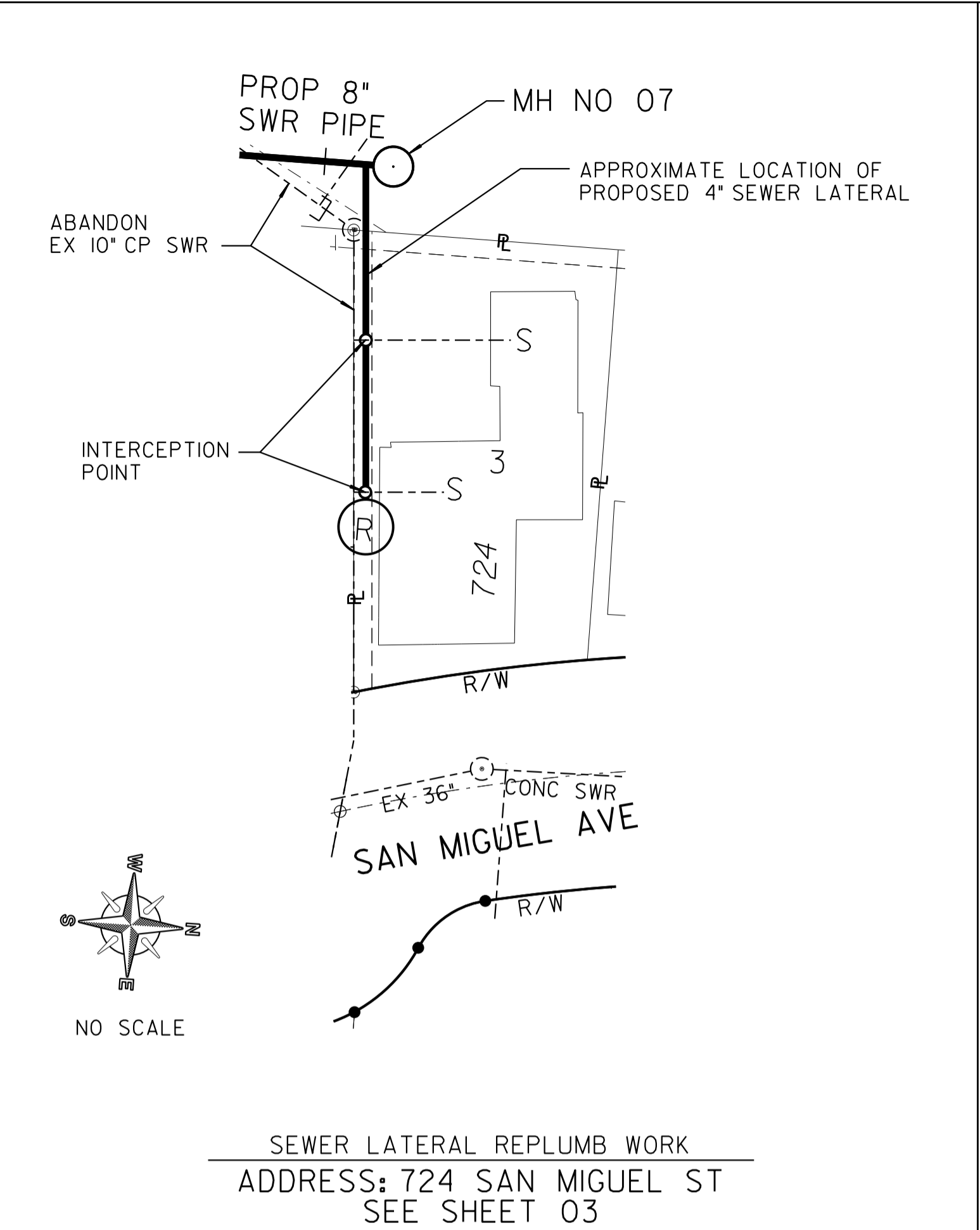
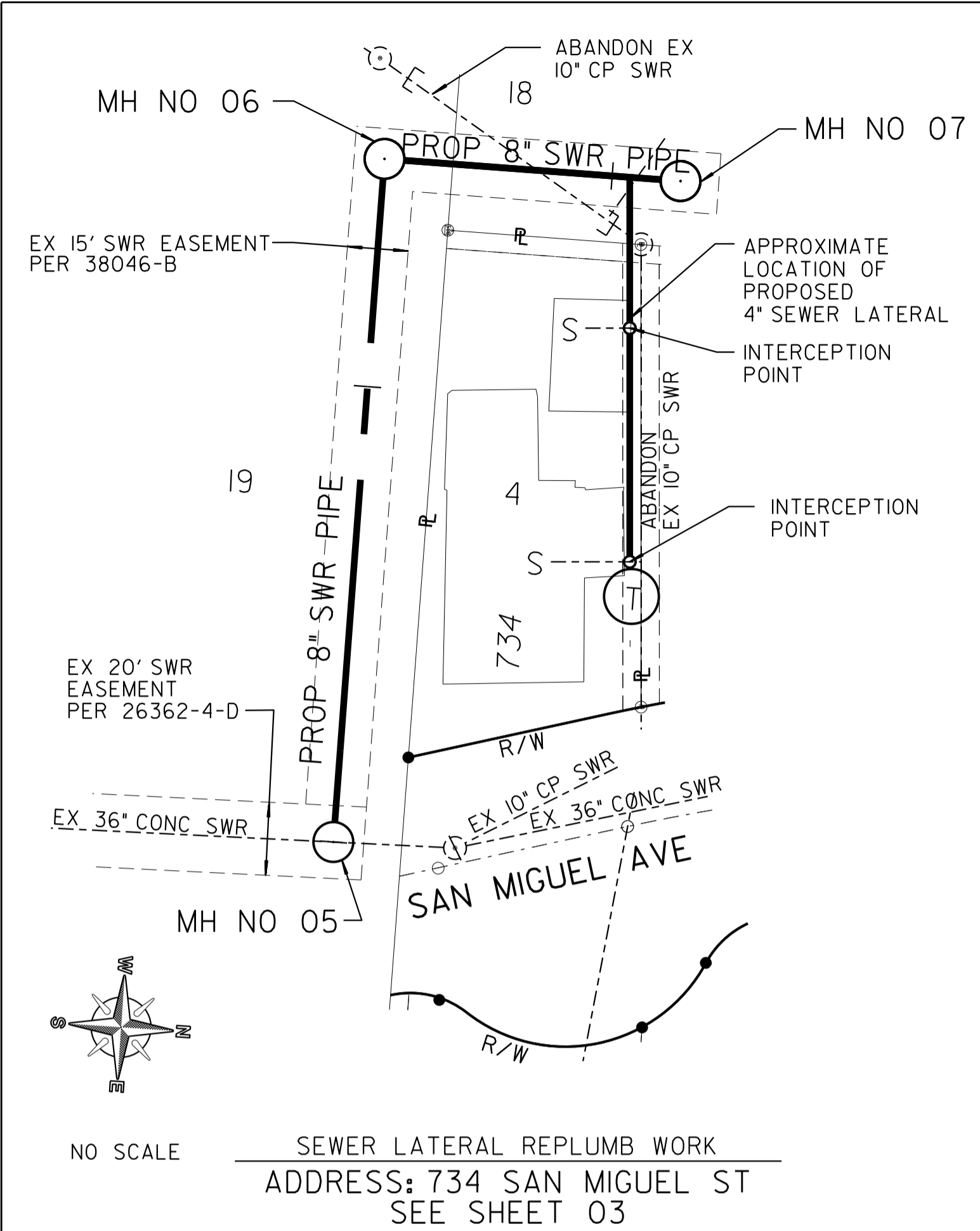

C-4

BOUNDARY ST AND EDMONTON AVE SMR  
SEWER LATERAL REPLUMB DETAILS

CITY OF SAN DIEGO, CALIFORNIA PUBLIC WORKS DEPARTMENT SHEET 05 OF 07 SHEETS		WATER WBS: N/A SEWER WBS: B13173			
FOR CITY ENGINEER <i>Rania Sarkis Amen</i> RANIA AMEN PRINT NAME	DATE: 8/8/2014	DESIGNED BY: JERICHO GALLARDO PROJECT ENGINEER			
DESCRIPTION	BY	APPROVED	DATE	FILMED	
ORIGINAL	JG/RH				
CONTRACTOR		DATE STARTED	37679-05-D		
INSPECTOR		DATE COMPLETED			

REGISTERED PROFESSIONAL ENGINEER  
RANIA SARKIS AMEN  
No. C 63507  
CIVIL  
STATE OF CALIFORNIA

SEWER LATERAL REPLUMB DETAILS

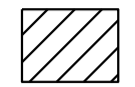
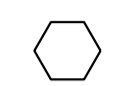

RESURFACING LEGEND

-  APPROXIMATE LOCATION OF SLURRY SEAL
-  LOCATION PER PAVING SCHEDULE NOTES (THIS SHEET)
- COLD MILLING ASPHALT CONCRETE PAVEMENT; SDG-106

PAVING SCHEDULE NOTES

NO.	LOCATION	RESTORATION REQUIRED	STATION	STATION	WIDTH	APPROX. AREA
1	UNIVERSITY CITY HIGH SCHOOL	SLURRY SEAL	0+80	4+50	30'	11,100 SF
TOTAL AREA OF SLURRY SEAL						11,100 SF

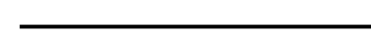
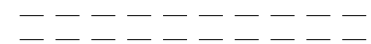
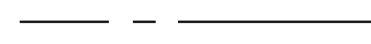
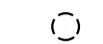
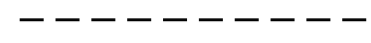
ABANDONMENT LEGEND

- RIGHT OF WAY 
- EASEMENT 
- EXISTING SEWER MAIN 
- EXISTING SEWER MANHOLE 
- EXISTING SEWER MAIN OUTSIDE OF TRENCH WIDTH TO BE ABANDONED IN ACCORDANCE WITH SPECIFICATIONS SECTION 306.5. 
- EXISTING SEWER MANHOLE OUTSIDE OF TRENCH WIDTH TO BE ABANDONED IN ACCORDANCE WITH SPECIFICATIONS SECTION 306.5. 
- SHEET NUMBER 

UNIVERSITY CITY HIGH SCHOOL

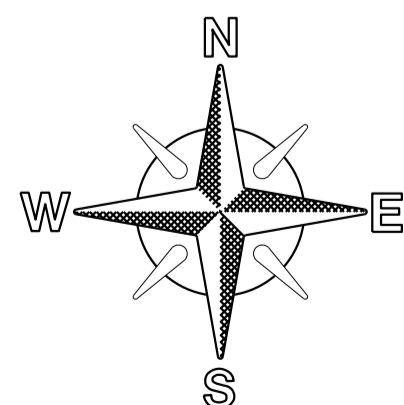
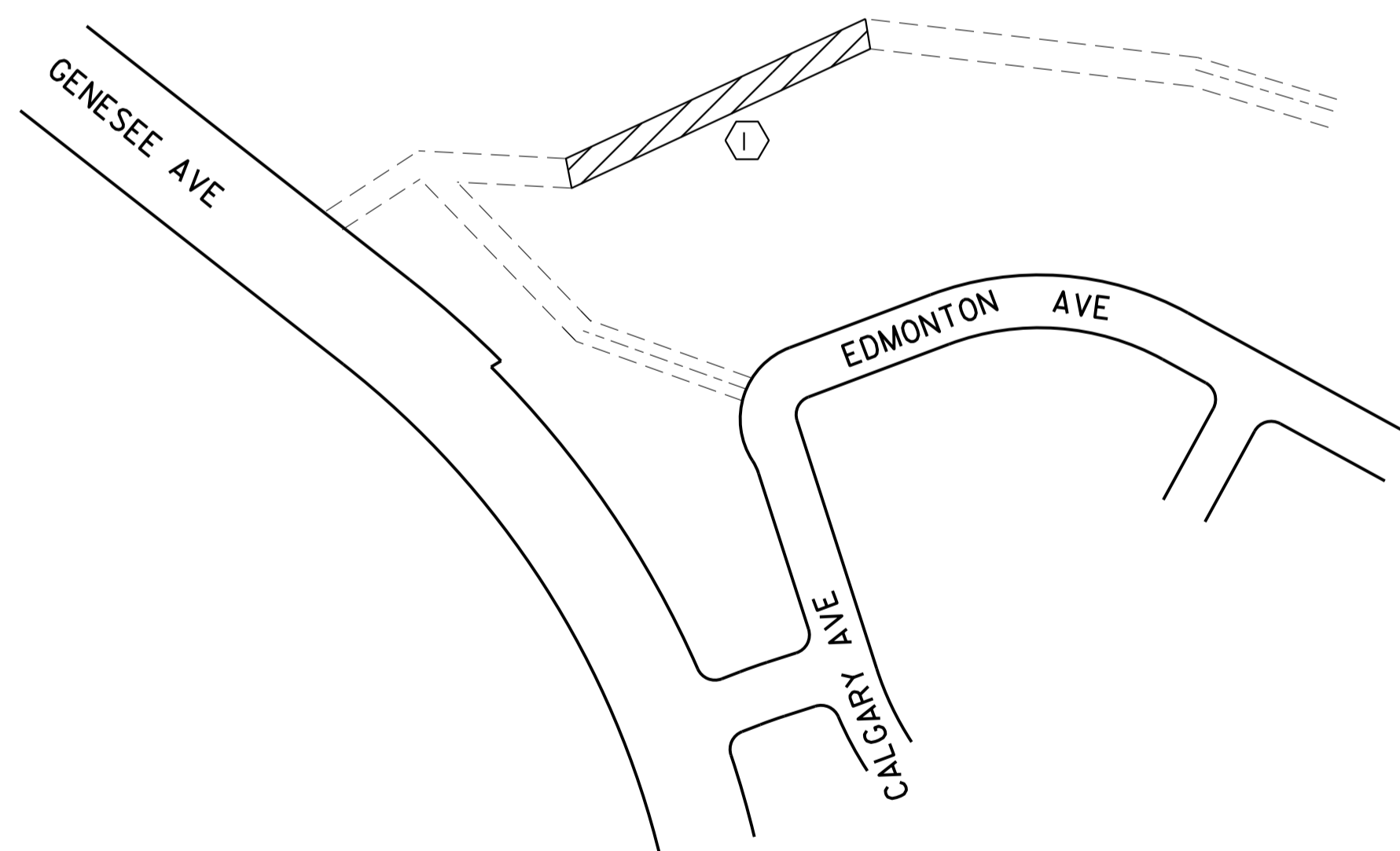

NO SCALE

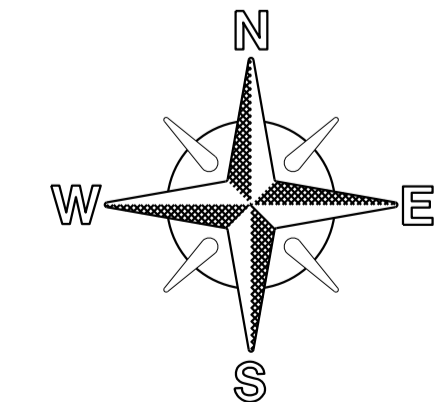
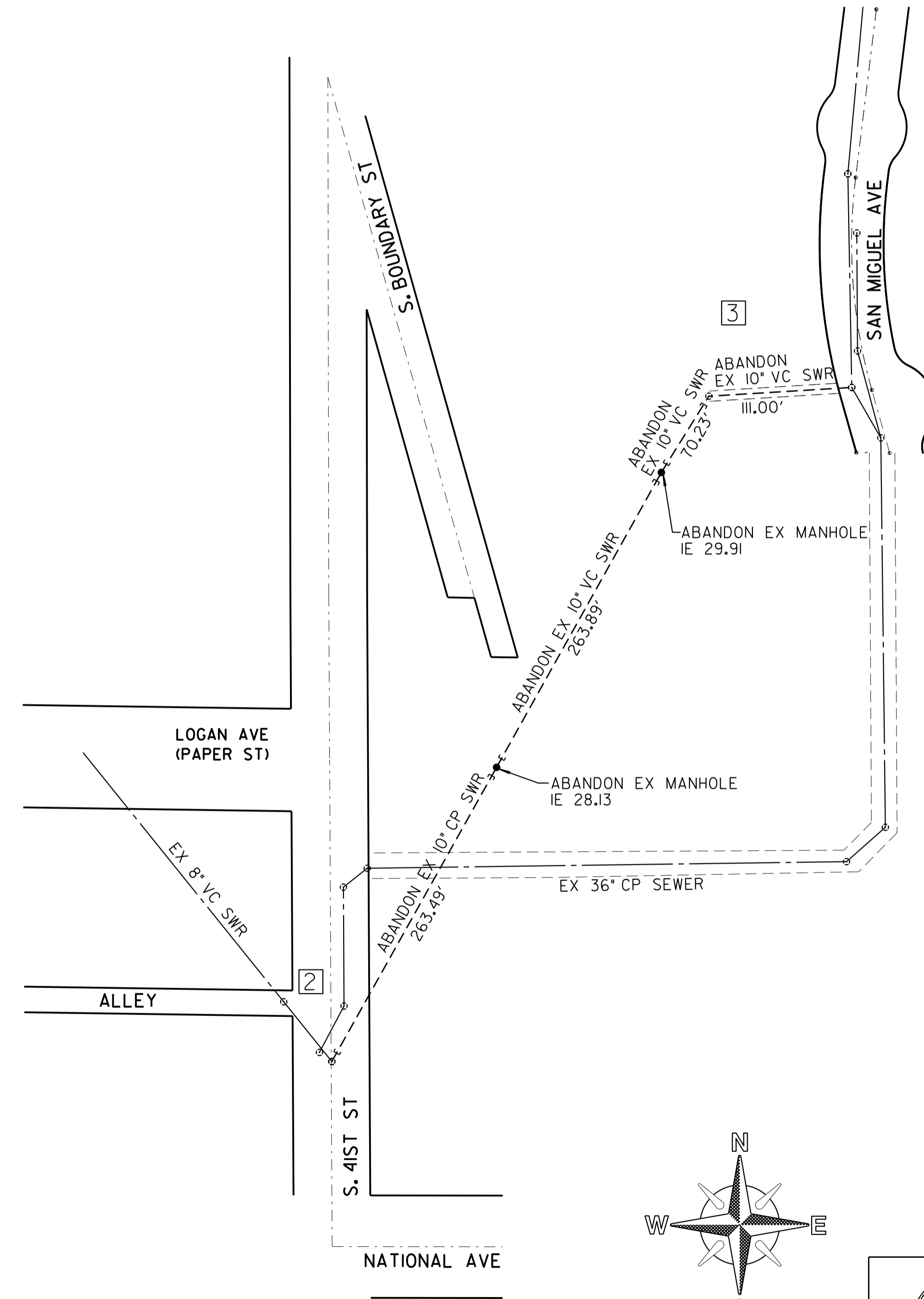

NO SCALE

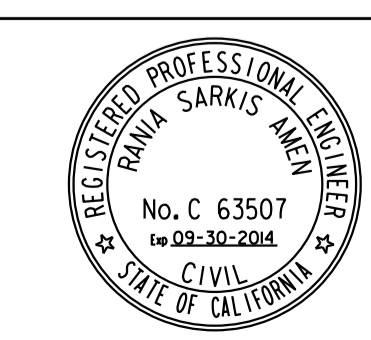

C-5

BOUNDARY ST AND EDMONTON AVE SMR  
STREET RESURFACING /SEWER ABANDONMENT

CITY OF SAN DIEGO, CALIFORNIA PUBLIC WORKS DEPARTMENT SHEET 06 OF 07 SHEETS		WATER WBS N/A SEWER WBS B13173
FOR CITY ENGINEER <i>Rania Sarkis Amen</i> RANIA AMEN PRINT NAME	DATE 8/8/2014	PROJECT MANAGER JERICHO GALLARDO
PROJECT ENGINEER JOSELITO GUINTO	DESCRIPTION	
PROJECT ENGINEER	BY	APPROVED
DATE	DATE	FILED
ORIGINAL	JG/RH	
SEE SHEETS CCS27 COORDINATE		
SEE SHEETS CCS83 COORDINATE		
CONTRACTOR	DATE STARTED	37679-06-D
INSPECTOR	DATE COMPLETED	



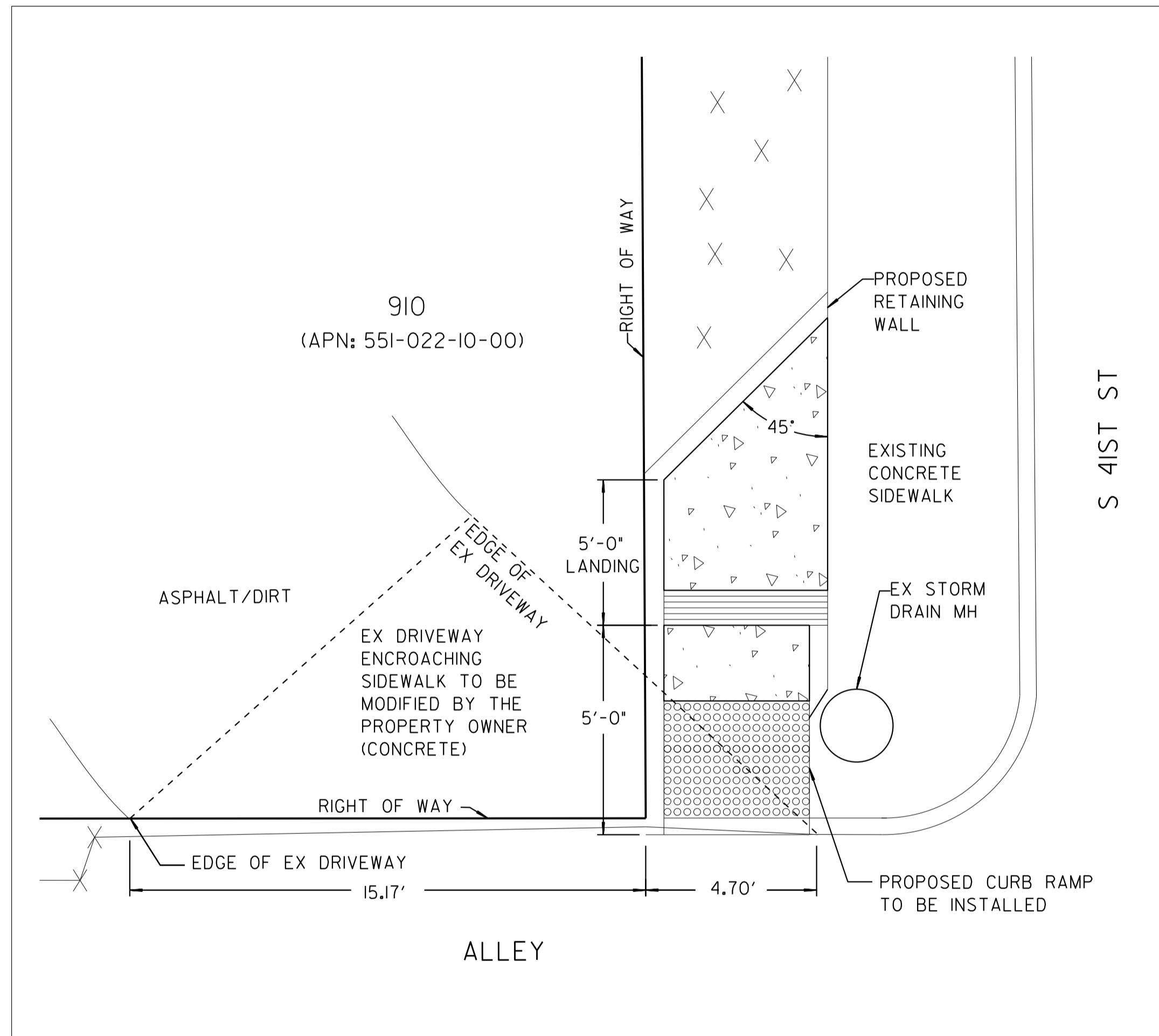
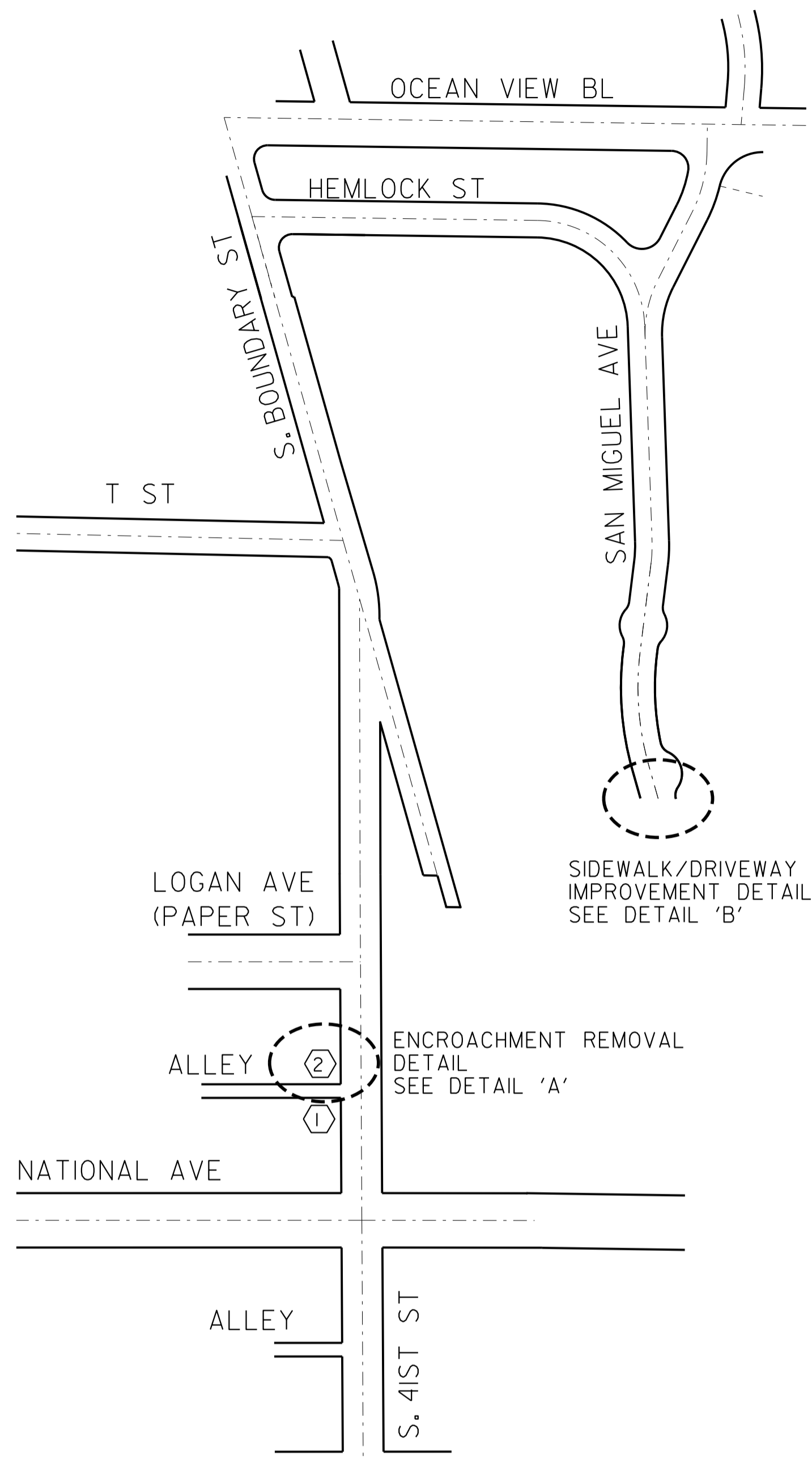

ENCROACHMENT REMOVAL - 910 S 41ST ST DETAIL  
DETAIL 'A'

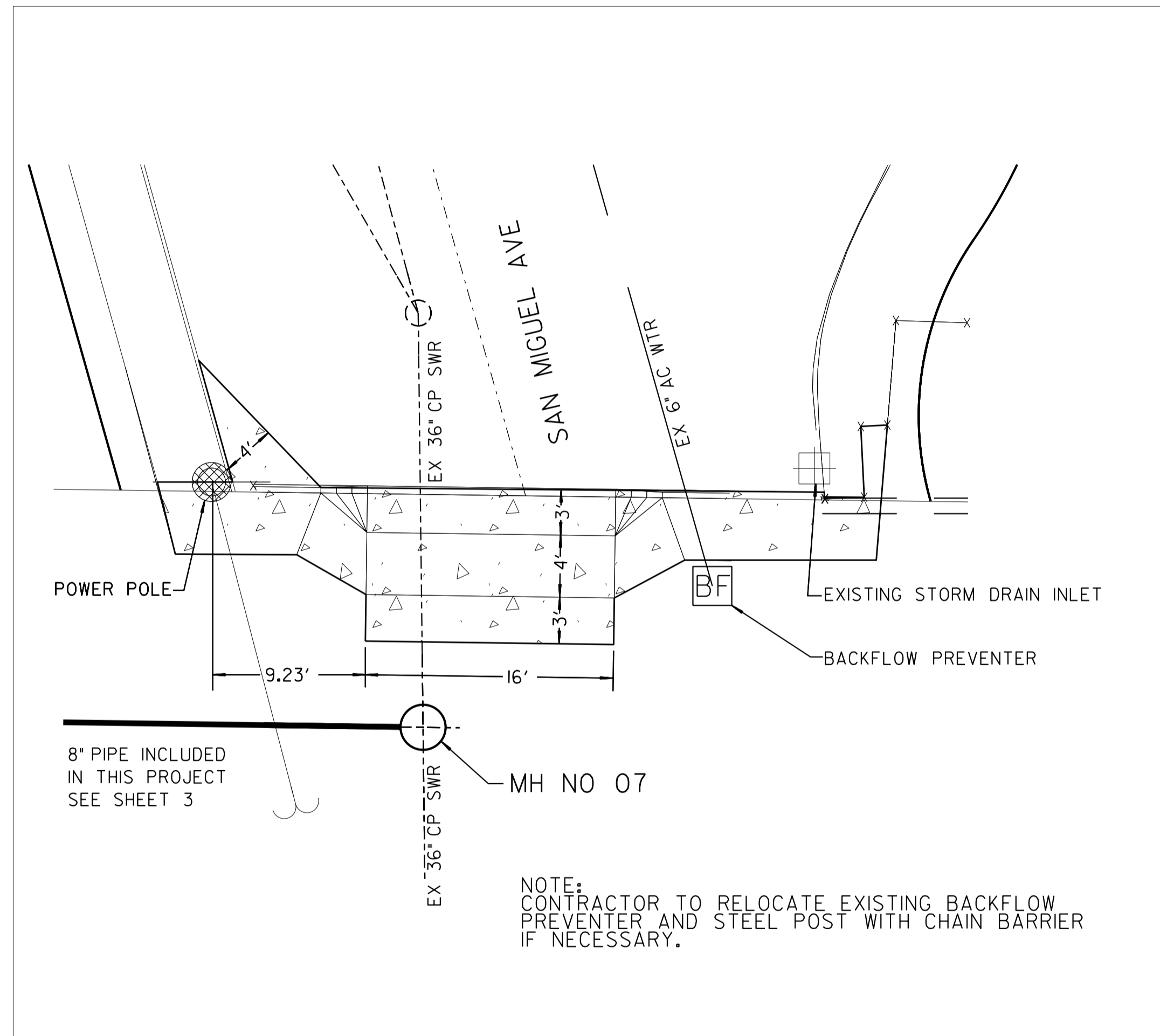

SIDEWALK/ DRIVEWAY IMPROVEMENT DETAIL  
DETAIL 'B'

CURB RAMP NOTES TABLE								
LOCATION NO.	RAMP TYPE	NEW	REPLACEMENT	HISTORIC STAMPS	DETECTABLE WARNING TILES		CONSTRAINTS	COMMENTS / MODIFICATIONS
					STAINLESS STEEL	OTHER		
1	D	-	-		-	-		GARAGE DOOR. COORDINATE WITH PROPERTY OWNER GERRY CROFOOT AT (619) 444-9253
2	D	-	-		-	-		STORM DRAIN MANHOLE. SEE DETAIL THIS SHEET

• THE DETECTABLE WARNING TILES SHALL BE PER THE CITY'S APPROVED MATERIALS LIST

**NOTE:**  
CONTRACTOR TO NOTIFY SURVEYING 30 DAYS PRIOR TO REMOVAL OF SIDEWALK FOR CURB RAMP CONSTRUCTION TO RELOCATE ANY SURVEY MARKERS.

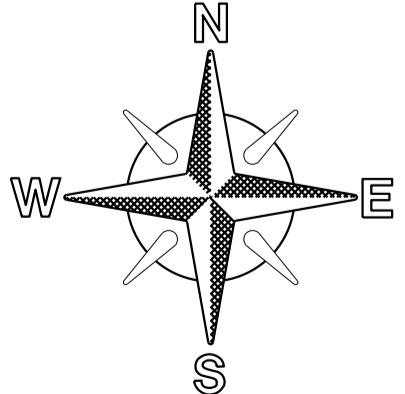

NO SCALE

LEGEND	
	PROPOSED SIDEWALK / DRIVEWAY AREA
	CURB RAMP NO's
	EX POWER POLE W/ DEADMAN
	EX FIRE HYDRANT
	EX STREET LIGHT
	EX TREE
	EX STREET SIGN
	EX CURB RAMP

PROPOSED CURB RAMP PER STANDARD DRAWINGS:	
CURB RAMP A & B	SDG-132
CURB RAMP - TYPE C1	SDG-134
CURB RAMP - TYPE C2	SDG-135
CURB RAMP - TYPE D	SDG-136
GENERAL CURB RAMP NOTES & SUPPLEMENTAL DETAILS	SDG-130
EX STAMP/IMPRESSION PLACEMENT	SDG-115



BOUNDARY ST AND EDMONTON AVE SMR  
CURB RAMP LOCATION/  
SIDEWALK & DRIVEWAY IMPROVEMENT DETAILS

CITY OF SAN DIEGO, CALIFORNIA PUBLIC WORKS DEPARTMENT SHEET 07 OF 07 SHEETS		WATER WBS: N/A SEWER WBS: B13173
FOR CITY ENGINEER RANIA AMEN PRINT NAME	DATE 8/8/2014	PROJECT MANAGER JOSELITO GUINTO
DESCRIPTION	BY	APPROVED
ORIGINAL	JG/RH	
DATE		
FILMED		
CONTRACTOR		DATE STARTED
INSPECTOR		DATE COMPLETED
		37679-07-D