

Mrs. Aida Banghart, Vice-President
Ortiz Corporation
2000 McKinley Avenue
National City, CA 91950
P: (619) 434-7925 F: (619) 434-7931

City of San Diego

CONTRACTOR'S NAME: _____
ADDRESS: _____
TELEPHONE NO.: _____ FAX NO.: _____
CITY CONTACT: Damian Singleton - Contract Specialist, Email: dsingleton@sandiego.gov
Phone No. (619) 533-3482, Fax No. (619) 533-3633
J. Gallardo / B. Doringo / ls

CONTRACT DOCUMENTS

FOR

ORIGINAL



SEWER GROUP 691

VOLUME 1 OF 2

BID NO.: _____ K-15-5875-DBB-3-C
SAP NO. (WBS/IO/CC): _____ B-00446
CLIENT DEPARTMENT: _____ 2011
COUNCIL DISTRICT: _____ 3
PROJECT TYPE: _____ JA

THIS CONTRACT IS SUBJECT TO THE FOLLOWING:

- PHASED-FUNDING.
- THE CITY'S SUBCONTRACTING PARTICIPATION REQUIREMENTS FOR SLBE PROGRAM.
- APPRENTICESHIP.

BID DUE DATE:

**2:00 PM
SEPTEMBER 30, 2014
CITY OF SAN DIEGO
PUBLIC WORKS CONTRACTS
1010 SECOND AVENUE, 14th FLOOR, MS 614C
SAN DIEGO, CA 92101**

ENGINEER OF WORK

The engineering Specifications and Special Provisions contained herein have been prepared by or under the direction of the following Registered Engineer:



For City Engineer

8/8/2014
Date

Seal:



TABLE OF CONTENTS

DESCRIPTION	PAGE NUMBER
1. TICE INVITING BIDS.....	4
2. CONTRACT FORMS	16
3. CONTRACT FORMS ATTACHMENTS:	
1. Performance Bond and Labor and Materialmen’s Bond	20
2. Drug-Free Workplace.....	22
3. American with Disabilities Act (ADA) Compliance Certification	23
4. Contractor Standards - Pledge of Compliance Certificate	24
5. Affidavit of Disposal Certificate	25
4. ATTACHMENTS:	
A. SCOPE OF WORK	27
B. PHASED FUNDING PROVISIONS	29
C. EQUAL OPPORTUNITY CONTRACTING PROGRAM	32
D. INTENTIONALLY LEFT BLANK.....	36
E. SUPPLEMENTARY SPECIAL PROVISIONS	37
SUPPLEMENTARY SPECIAL PROVISIONS APPENDICES:	
1. Appendix A – Site Development Permit and Mitigated Negative Declaration	64
2. Appendix B - Fire Hydrant Meter Program	99
3. Appendix C - Materials Typically Accepted by Certificate of Compliance	113
4. Appendix D - Sample City Invoice	115
5. Appendix E - Location Map.....	117
6. Appendix F - Long-term Revegetation Maintenance Contract	119
7. Appendix G - Sewer Mains and Manhole Rehabilitation Sample Data Templates .	136
8. Appendix H - Sample Archaeology Invoice	139
9. Appendix I – Adjacent Project	142
10. Appendix J – Agreement For Application of Emulsion – Aggregate Slurry	144
F. INTENTIONALLY LEFT BLANK.....	153

CITY OF SAN DIEGO, CALIFORNIA

NOTICE INVITING BIDS

1. **RECEIPT AND OPENING OF BIDS:** Bids will be received at the Public Works Contracts at the location, time, and date shown on the cover of these specifications for performing work on **Sewer Group 691** (Project).
2. **SUMMARY OF WORK:** The Work involves furnishing all labor, materials, equipment, services, and other incidental works and appurtenances for the construction of the Project as described in ATTACHMENT A.
3. **BIDS ARE PUBLIC RECORDS:** Upon receipt by the City, Bids shall become public records subject to public disclosure. It is the responsibility of the respondent to clearly identify any confidential, proprietary, trade secret or otherwise legally privileged information contained within the Bid. General references to sections of the California Public Records Act (PRA) will not suffice. If the Contractor does not provide applicable case law that clearly establishes that the requested information is exempt from the disclosure requirements of the PRA, the City shall be free to release the information when required in accordance with the PRA, pursuant to any other applicable law, or by order of any court or government agency, and the Contractor will hold the City harmless for release of this information.
4. **SUBCONTRACTING PARTICIPATION PERCENTAGES:**
 - 4.1. The City has incorporated **mandatory** SLBE-ELBE subcontractor participation percentages to enhance competition and maximize subcontracting opportunities. For the purpose of achieving the mandatory subcontractor participation percentages, a recommended breakdown of the SLBE and ELBE subcontractor participation percentages based upon certified SLBE and ELBE firms has also been provided to achieve the mandatory subcontractor participation percentages:

1.	SLBE participation	6.8%
2.	ELBE participation	15.5%
3.	Total mandatory participation	22.3%
 - 4.2. The Bidders are strongly encouraged to attend the Pre-Bid Meeting to better understand the Good Faith Effort requirements of this contract. See the City's document titled "SLBE Program, Instructions For Bidders Completing The Good Faith Effort Submittal" available at: <http://www.sandiego.gov/eoc/>
 - 4.3. The Bid will be declared non-responsive if the Bidder fails the following mandatory conditions:
 - 4.3.1. Bidder's inclusion of SLBE-ELBE certified subcontractors at the overall mandatory participation percentage identified in this document; OR.
 - 4.3.2. Bidder's submission of Good Faith Effort documentation demonstrating the Bidder made a good faith effort to outreach to and include SLBE-ELBE Subcontractors required in this document within **3 Working Days** of the Bid opening if the overall mandatory participation percentage is not met.

- 4.4. For additional Equal Opportunity Contracting Program requirements, see Attachment C.
5. **PRE-BID MEETING:**
- 5.1. There will be a Pre-Bid Meeting to discuss the scope of the Project, bidding requirements, pre-qualification process, and Equal Opportunity Contracting Program requirements and reporting procedures in the Public Works Contracts, Conference Room at 1010 Second Avenue, 14th Floor, San Diego, CA 92101 at **10:00 A.M.**, on **September 4, 2014**.
- 5.2. All potential bidders are encouraged to attend.
- 5.3. To request a copy of the agenda on an alternative format, or to request a sign language or oral interpreter for this meeting, call the Public Works Contracts at (619) 533-3450 at least 5 Working Days prior to the Pre-Bid Meeting to ensure availability.
6. **CONTRACTOR REGISTRATION AND ELECTRONIC REPORTING SYSTEM:**
- 6.1. **Prior** to the Award of the Contract or each Task Order, you and your Subcontractors and Suppliers must register with the City's web-based contract compliance website, Prism®, located here:
- <https://pro.prismcompliance.com/default.aspx>.
- 6.2. The City may not award the contract until registration of all subcontractors and suppliers is complete. In the event this requirement is not met within the time frame specified in the Notice of Intent to Award letter, the City reserves the right to rescind the Notice of Award / Intent to Award and to make the award to the next responsive and responsible bidder / proposer.
7. **JOINT VENTURE CONTRACTORS:** Provide a copy of the Joint Venture agreement and the Joint Venture license to the City within 10 Working Days after receiving the Contract forms. See 2-1.1.2, "Joint Venture Contractors" in The WHITEBOOK for details.
8. **PREVAILING WAGE RATES:** Pursuant to San Diego Municipal Code section 22.3019, construction, alteration, demolition, repair and maintenance work performed under this Contract is subject to State prevailing wage laws. For construction work performed under this Contract cumulatively exceeding \$25,000 and for alteration, demolition, repair and maintenance work performed under this Contract cumulatively exceeding \$15,000, the Contractor and its subcontractors shall comply with State prevailing wage laws including, but not limited to, the requirements listed below.
- 8.1. **Compliance with Prevailing Wage Requirements.** Pursuant to sections 1720 through 1861 of the California Labor Code, the Contractor and its subcontractors shall ensure that all workers who perform work under this Contract are paid not less than the prevailing rate of per diem wages as determined by the Director of the California Department of Industrial Relations (DIR). This includes work performed during the design and preconstruction phases of construction including, but not limited to, inspection and land surveying work.

- 8.2.** Copies of such prevailing rate of per diem wages are on file at the City and are available for inspection to any interested party on request. Copies of the prevailing rate of per diem wages also may be found at <http://www.dir.ca.gov/OPRL/DPreWageDetermination.htm>. Contractor and its subcontractors shall post a copy of the prevailing rate of per diem wages determination at each job site and shall make them available to any interested party upon request.
- 8.3.** The wage rates determined by the DIR refer to expiration dates. If the published wage rate does not refer to a predetermined wage rate to be paid after the expiration date, then the published rate of wage shall be in effect for the life of this Contract. If the published wage rate refers to a predetermined wage rate to become effective upon expiration of the published wage rate and the predetermined wage rate is on file with the DIR, such predetermined wage rate shall become effective on the date following the expiration date and shall apply to this Contract in the same manner as if it had been published in said publication. If the predetermined wage rate refers to one or more additional expiration dates with additional predetermined wage rates, which expiration dates occur during the life of this Contract, each successive predetermined wage rate shall apply to this Contract on the date following the expiration date of the previous wage rate. If the last of such predetermined wage rates expires during the life of this Contract, such wage rate shall apply to the balance of the Contract.
- 8.4. Penalties for Violations.** Contractor and its subcontractors shall comply with California Labor Code section 1775 in the event a worker is paid less than the prevailing wage rate for the work or craft in which the worker is employed.
- 8.5. Payroll Records.** Contractor and its subcontractors shall comply with California Labor Code section 1776, which generally requires keeping accurate payroll records, verifying and certifying payroll records, and making them available for inspection. Contractor shall require its subcontractors to also comply with section 1776. Contractor and its subcontractors shall submit weekly certified payroll records online via the City's web-based Labor Compliance Program. Contractor is responsible for ensuring its subcontractors submit certified payroll records to the City.
- 8.6. Apprentices.** Contractor and its subcontractors shall comply with California Labor Code sections 1777.5, 1777.6 and 1777.7 concerning the employment and wages of apprentices. Contractor shall be held responsible for the compliance of their subcontractors with sections 1777.5, 1777.6 and 1777.7.
- 8.7. Working Hours.** Contractor and subcontractors shall comply with California Labor Code sections 1810 through 1815, including but not limited to: (i) restrict working hours on public works contracts to eight hours a day and forty hours a week, unless all hours worked in excess of 8 hours per day are compensated at not less than 1½ times the basic rate of pay; and (ii) specify penalties to be imposed on design professionals and subcontractors of \$25 per worker per day for each day the worker works more than 8 hours per day and 40 hours per week in violation of California Labor Code sections 1810 through 1815.

- 8.8. Required Provisions for Subcontracts.** Contractor shall include at a minimum a copy of the following provisions in any contract they enter into with a subcontractor: California Labor Code sections 1771, 1775, 1776, 1777.5, 1810, 1813, 1815, 1860 and 1861.
- 8.9. Labor Code Section 1861 Certification.** Contractor in accordance with California Labor Code section 3700 is required to secure the payment of compensation of its employees and by signing this Contract, Contractor certifies that “I am aware of the provisions of Section 3700 of the California Labor Code which require every employer to be insured against liability for workers’ compensation or to undertake self-insurance in accordance with the provisions of that code, and I will comply with such provisions before commencing the performance of the work of this Contract.”
- 8.10. Labor Compliance Program.** The City has its own Labor Compliance Program as authorized by the DIR. The City will withhold contract payments when payroll records are delinquent or deemed inadequate by the City or other governmental entity, or it has been established after an investigation by the City or other governmental entity that underpayment(s) have occurred.

9. INSURANCE REQUIREMENTS:

- 9.1.** All certificates of insurance and endorsements required by the contract are to be provided upon issuance of the City’s Notice of Intent to Award letter.
- 9.2.** Refer to sections 7-3, “LIABILITY INSURANCE”, and 7-4, “WORKERS’ COMPENSATION INSURANCE” of the Supplementary Special Provisions (SSP) for the insurance requirements which must be met.

10. PREQUALIFICATION OF CONTRACTORS:

- 10.1.** Contractors submitting Bid must be pre-qualified for the total amount proposed, inclusive of all alternate items prior to the date of submittal. Bids from contractors who have not been pre-qualified as applicable and Bids that exceed the maximum dollar amount at which contractors are pre-qualified will be deemed **non-responsive** and ineligible for award. Complete information and prequalification questionnaires are available at:

<http://www.sandiego.gov/cip/bidopps/prequalification.shtml>

- 10.2.** The completed questionnaire, financial statement, and bond letter or a copy of the contractor’s SLBE-ELBE certification and bond letter, must be submitted no later than 2 weeks prior to the bid opening to the Public Works Contracts, Prequalification Program, 1010 Second Avenue, 14th Floor, San Diego, CA 92101. For additional information or the answer to questions about the prequalification program, contact David Stucky at 619-533-3474 or dstucky@sandiego.gov.

11. **REFERENCE STANDARDS:** Except as otherwise noted or specified, the Work shall be completed in accordance with the following standards:

Title	Edition	Document Number
Standard Specifications for Public Works Construction (“The GREENBOOK”)	2012	PITS070112-01
City of San Diego Standard Specifications for Public Works Construction (“The WHITEBOOK”)*	2012	PITS070112-02
City of San Diego Standard Drawings*	2012	PITS070112-03
Caltrans Standard Specifications	2010	PITS070112-04
Caltrans Standard Plans	2010	PITS070112-05
California MUTCD	2012	PITS070112-06
City Standard Drawings - Updates Approved For Use (when specified)*	Varies	Varies
Standard Federal Equal Employment Opportunity Construction Contract Specifications and the Equal Opportunity Clause Dated 09-11-84	1984	769023
NOTE: *Available online under Engineering Documents and References at: http://www.sandiego.gov/publicworks/edocref/index.shtml		

12. **CITY'S RESPONSES AND ADDENDA:** The City at its option, may respond to any or all questions submitted in writing, via letter, or FAX in the form of an addendum. No oral comment shall be of any force or effect with respect to this solicitation. The changes to the Contract Documents through addendum are made effective as though originally issued with the Bid. The Bidders shall acknowledge the receipt of Addenda on the form provided for this purpose in the Bid.
13. **CITY'S RIGHTS RESERVED:** The City reserves the right to cancel the Notice Inviting Bids at any time, and further reserves the right to reject submitted Bids, without giving any reason for such action, at its sole discretion and without liability. Costs incurred by the Bidder(s) as a result of preparing Bids under the Notice Inviting Bids shall be the sole responsibility of each bidder. The Notice Inviting Bids creates or imposes no obligation upon the City to enter a contract.
14. **CONTRACT PRICING FORMAT:** This solicitation is for a Lump Sum contract with Unit Price provisions as set forth in the Bid Proposal Form(s), Volume 2.
15. **SUBMITTAL OF “OR EQUAL” ITEMS:** See Section 4-1.6, “Trade Names or Equals” in The WHITEBOOK and as amended in the SSP.
16. **AWARD PROCESS:**
- 16.1. The Award of this contract is contingent upon the Contractor’s compliance with all conditions precedent to Award.

- 16.2.** Upon acceptance of a Bid, the City will prepare contract documents for execution within approximately 21 days of the date of the Bid opening and award the Contract approximately within 7 days of receipt of properly executed Contract, bonds, and insurance documents.
- 16.3.** This contract will be deemed executed, and effective, only upon the signing of the Contract by the Mayor or designee of the City.
- 17. SUBCONTRACT LIMITATIONS:** The Bidder's attention is directed to Standard Specifications for Public Works Construction, Section 2-3, "SUBCONTRACTS" in The GREENBOOK and as amended in the SSP which requires the Contractor to self-perform not less than the specified amount. Failure to comply with this requirement shall render the bid **non-responsive** and ineligible for award.
- 18. AVAILABILITY OF PLANS AND SPECIFICATIONS:** Contract Documents may be obtained by visiting the City's website: <http://www.sandiego.gov/cip/>. Plans and Specifications for this contract are also available for review in the office of the City Clerk or Public Works Contracts.
- 19. SUBMISSION OF QUESTIONS:**
- 19.1.** The Director (or designee), of the Public Works Department is the officer responsible for opening, examining, and evaluating the competitive Bids submitted to the City for the acquisition, construction and completion of any public improvement except when otherwise set forth in these documents. All questions related to this solicitation shall be submitted to:
- Public Works Contracts
1010 Second Avenue, 14th Floor
San Diego, California, 92101
Attention: [Contract Specialist listed on the front cover hereof]
- OR:
- Email address of the Contract Specialist listed on the front cover hereof.
- 19.2.** Questions received less than 14 days prior to the date for opening of Bids may not be considered.
- 19.3.** Clarifications deemed by the City to be material shall be issued by Addenda and uploaded to the City's online bidding service.
- 19.4.** Only questions answered by formal written addenda will be binding. Oral and other interpretations or clarifications will be without legal effect. It is the Bidder's responsibility to become informed of any Addenda that have been issued and to include all such information in its Bid.
- 20. ELIGIBLE BIDDERS:** No person, firm, or corporation shall be allowed to make, file, or be interested in **more** than one (1) Bid for the same work unless alternate Bids are called for. A person, firm or corporation who has submitted a sub-proposal to a Bidder, or who has quoted prices on materials to a Bidder, is not hereby disqualified from submitting a sub-proposal or

quoting prices to other Bidders or from submitting a Bid in its own behalf. Any Bidder who submits more than one bid will result in the rejection of all bids submitted.

21. SAN DIEGO BUSINESS TAX CERTIFICATE: The Contractor and Subcontractors, not already having a City of San Diego Business Tax Certificate for the work contemplated shall secure the appropriate certificate from the City Treasurer, Civic Center Plaza, first floor and submit to the Contract Specialist upon request or as specified in the Contract Documents. Tax Identification numbers for both the Bidder and the listed Subcontractors must be submitted on the City provided forms with the Notice Inviting Bids and Contract forms.

22. PROPOSAL FORMS: Bid shall be made only upon the Bidding Documents i.e., Proposal form attached to and forming a part of the specifications. The signature of each person signing shall be in longhand.

22.1. Bidder shall complete and submit all pages in the "Bidding Document" Section (see Volume 2) as their Bid per the schedule given under "Required Documents Schedule," (see Volume 1). Bidder is requested to retain for their reference other portions of the Contract Documents that are not required to be submitted with the Bid. The entire specifications for the bid package do not need to be submitted with the bid.

22.2. The City may require any Bidder to furnish a statement of experience, financial responsibility, technical ability, equipment, and references.

22.3. Bids and certain other forms and documents as specified in the Volume 2 of 2 of the Contract Documents shall be enclosed in a sealed envelope and shall bear the title of the work and name of the Bidder and the appropriate State Contractors License designation which the Bidder holds.

22.4. Bids may be withdrawn by the Bidder prior to, but not after, the time fixed for opening of Bids.

23. BIDDER'S GUARANTEE OF GOOD FAITH (BID SECURITY):

23.1. With the exception of the contracts valued \$5,000 or less, JOC and Design-Build contracts, and contracts subject to the Small and Local Business Program of \$250,000 or less e.g., ELBE contracts, each Bidder shall accompany its Bid with either a cashier's check upon some responsible bank, or a check upon such bank properly certified or an approved corporate surety bond payable to the City of San Diego, for an amount of not less than 10% of the aggregate sum of the Bid, which check or bond, and the monies represented thereby shall be held by the City as a guarantee that the Bidder, if awarded the contract, will in good faith enter into such contract and furnish the required final bonds.

23.2. The Bidder agrees that in case of Bidder's refusal or failure to execute this contract and give required final bonds, the money represented by a cashier's or certified check shall remain the property of the City, and if the Bidder shall fail to execute this contract, the Surety agrees that it will pay to the City damages which the City may suffer by reason of such failure, not exceeding the sum of 10% of the amount of the Bid.

23.3. A Bid received without the specified bid security will be rejected as being **non-responsive**.

24. AWARD OF CONTRACT OR REJECTION OF BIDS:

24.1. This contract may be awarded to the lowest responsible and reliable Bidder.

24.2. Bidders shall complete the entire Bid schedule (also referred to as “schedule of prices” or Proposal form). Incomplete price schedules will be rejected as being non-responsive.

24.3. The City reserves the right to reject any or all Bids, and to waive any informality or technicality in Bids received and any requirements of these specifications as to bidding procedure.

24.4. Bidders will not be released on account of their errors of judgment. Bidders may be released only upon receipt by the City from the Bidder within 3 Working Days, excluding Saturdays, Sundays, and state holidays, after the opening of Bids, of written notice which includes proof of honest, credible, clerical error of material nature, free from fraud or fraudulent intent, and of evidence that reasonable care was observed in the preparation of the Bid.

24.5. A non-selected Bidder may protest award of the Contract to the selected Bidder by submitting a written “Notice of Intent to Protest” including supporting documentation which shall be received by Public Works Contracts no later than 10 days after the City’s announcement of the selected Bidder or no later than 10 days from the date that the City issues notice of designation of a Bidder as non-responsive in accordance with San Diego Municipal Code Chapter 2, § 22.3029, “Protests of Contract Award.”

24.6. The City of San Diego will not discriminate with regard to race, religious creed, color, national origin, ancestry, physical handicap, marital status, sex or age, in the award of contracts.

24.7. Each Bid package properly executed as required by these specifications shall constitute a firm offer, which may be accepted by the City within the time specified in the Proposal.

24.8. The City reserves the right to evaluate all Bids and determine the lowest Bidder on the basis of any proposed alternates, additive items or options, at its discretion that will be disclosed in the Volume 2 of 2.

25. BID RESULTS:

25.1. The Bid opening by the City shall constitute the public announcement of the Apparent Low Bidder. In the event that the Apparent Low Bidder is subsequently deemed non-responsive or non-responsible, a public announcement will be posted in the City’s web page <http://www.sandiego.gov/cip/index.shtml>, with the name of the newly designated Apparent Low Bidder.

25.2. To obtain Bid results, either attend Bid opening, review the results on the City’s web site, or provide a self-addressed, stamped envelope, referencing Bid number, and Bid tabulation will be mailed to you upon verification of extensions. Bid results cannot be given over the telephone.

26. THE CONTRACT:

- 26.1.** The Bidder to whom award is made shall execute a written contract with the City of San Diego and furnish good and approved bonds and insurance certificates specified by the City within 14 days after receipt by Bidder of a form of contract for execution unless an extension of time is granted to the Bidder in writing.
- 26.2.** If the Bidder takes longer than 14 days to fulfill these requirements, then the additional time taken shall be added to the Bid guarantee. The Contract shall be made in the form adopted by the City, which includes the provision that no claim or suit whatsoever shall be made or brought by Contractor against any officer, agent, or employee of the City for or on account of anything done or omitted to be done in connection with this contract, nor shall any such officer, agent, or employee be liable hereunder.
- 26.3.** If the Bidder to whom the award is made fails to enter into the contract as herein provided, the award may be annulled and the Bidder's Guarantee of Good Faith will be subject to forfeiture. An award may be made to the next lowest responsible and reliable Bidder who shall fulfill every stipulation embraced herein as if it were the party to whom the first award was made.
- 26.4.** Pursuant to the San Diego City Charter section 94, the City may only award a public works contract to the lowest responsible and reliable Bidder. The City will require the Apparent Low Bidder to (i) submit information to determine the Bidder's responsibility and reliability, (ii) execute the Contract in form provided by the City, and (iii) furnish good and approved bonds and insurance certificates specified by the City within 14 Days, unless otherwise approved by the City, in writing after the Bidder receives notification from the City, designating the Bidder as the Apparent Low Bidder and formally requesting the above mentioned items.
- 26.5.** The award of the Contract is contingent upon the satisfactory completion of the above mentioned items and becomes effective upon the signing of the Contract by the Mayor or designee. If the Apparent Low Bidder does not execute the Contract or submit required documents and information, the City may award the Contract to the next lowest responsible and reliable Bidder who shall fulfill every condition precedent to award. A corporation designated as the Apparent Low Bidder shall furnish evidence of its corporate existence and evidence that the officer signing the Contract and bond for the corporation is duly authorized to do so.

- 27. EXAMINATION OF PLANS, SPECIFICATIONS, AND SITE OF WORK:** The Bidder shall examine carefully the Project Site, the Plans and Specifications, other materials as described in the Special Provisions, Section 2-7, and the proposal forms (e.g., Bidding Documents). The submission of a Bid shall be conclusive evidence that the Bidder has investigated and is satisfied as to the conditions to be encountered, as to the character, quality, and scope of Work, the quantities of materials to be furnished, and as to the requirements of the Bidding Documents Proposal, Plans, and Specifications.

- 28. CITY STANDARD PROVISIONS:** This contract is subject to the following standard provisions. See The WHITEBOOK for details.
- 28.1.** The City of San Diego Resolution No. R-277952 adopted on May 20, 1991 for a Drug-Free Workplace.
 - 28.2.** The City of San Diego Resolution No. R-282153 adopted on June 14, 1993 related to the Americans with Disabilities Act.
 - 28.3.** The City of San Diego Municipal Code §22.3004 for Pledge of Compliance.
 - 28.4.** The City of San Diego’s Labor Compliance Program and the State of California Labor Code §§1771.5(b) and 1776.
 - 28.5.** Sections 1777.5, 1777.6, and 1777.7 of the State of California Labor Code concerning the employment of apprentices by contractors and subcontractors performing public works contracts.
 - 28.6.** The City’s Equal Benefits Ordinance (EBO), Chapter 2, Article 2, Division 43 of The San Diego Municipal Code (SDMC).
 - 28.7.** The City’s Information Security Policy (ISP) as defined in the City’s Administrative Regulation 90.63.
- 29. PRE-AWARD ACTIVITIES:**
- 29.1.** The selected contractor by the City to execute a contract for this Work shall provide the information required within the time specified in “Required Documents,” of this bid package. Failure to provide the information within the time specified may result in the Bid being rejected as **non-responsive**.
 - 29.2.** If the Bid is rejected as non-responsive, the selected contractor by the City to execute a contract for this Work shall forfeit the required Bid. The decision that the selected contractor by the City to execute a contract for this Work is non-responsive for failure to provide the information required within the time specified shall be at the sole discretion of the City.
- 30. SUPPLEMENTAL AGREEMENTS:** Supplemental agreements attached to this contract for the items of Work such as extended revegetation maintenance and monitoring and emulsion aggregate slurry shall be signed by the BIDDER at the time of submission of the primary BID. The signed agreements shall be accompanied by the evidence of a bond (i.e., labor and materials) and insurance as specified in 2-4, “CONTRACT BONDS,” 7-3, “LIABILITY INSURANCE,” and 7-4 WORKERS’ COMPENSATION INSURANCE. Bonds shall be in amount of the Contract Price for the Work included in the supplemental agreements.
- 30.1. Partial Release of Performance Bond and Labor and Materialmen’s Bond:** For information regarding partial release of bonds for this Contract, see Supplementary Special Provisions, Appendix “F”.
- 31. PHASED FUNDING:**
- For additional Phased Funding Provisions, see Attachment B.

32. REQUIRED DOCUMENT SCHEDULE:

32.1. The Bidder’s attention is directed to the City’s Municipal Code §22.0807(e), (3)-(5) for important information regarding grounds for debarment for failure to submit required documentation.

32.2. The specified Equal Opportunity Contracting Program (EOCP) forms are available for download from the City’s web site at:

<http://www.sandiego.gov/eoc/forms/index.shtml>

ITEM	WHEN DUE	FROM	DOCUMENT TO BE SUBMITTED
1.	BID SUBMITTAL DATE/TIME	ALL BIDDERS	Bid
2.	BID SUBMITTAL DATE/TIME	ALL BIDDERS	Bid Bond
3.	BID SUBMITTAL DATE/TIME	ALL BIDDERS	Non-collusion Affidavit to be Executed By Bidder and Submitted with Bid under 23 USC 112 and PCC 7106
4.	BID SUBMITTAL DATE/TIME	ALL BIDDERS	Contractors Certification of Pending Actions
5.	BID SUBMITTAL DATE/TIME	ALL BIDDERS	Equal Benefits Ordinance Certification of Compliance
6.	BID SUBMITTAL DATE/TIME	ALL BIDDERS	Form AA35 - List of Subcontractors
7.	BID SUBMITTAL DATE/TIME	ALL BIDDERS	Form AA40 - Named Equipment/Material Supplier List
8.	WITHIN 3 WORKING DAYS OF BID OPENING	ALL BIDDERS	SLBE Good Faith Efforts Documentation
9.	WITHIN 3 WORKING DAYS OF BID OPENING WITH GOOD FAITH EFFORT DOCUMENTATION	ALL BIDDERS	Form AA60 – List of Work Made Available
10.	WITHIN 3 WORKING DAYS OF BID OPENING WITH GOOD FAITH EFFORT DOCUMENTATION	ALL BIDDERS	Proof of Valid DBE-MBE-WBE-DVBE Certification Status e.g., Certs.
11.	PRIOR TO PRE-CONSTRUCTION MEETING	LOW BIDDER	Contractor’s Experience and Past Project Documentation. See Section 700
12.	PRIOR TO PRE-CONSTRUCTION MEETING	LOW BIDDER	Contractor’s Experience and Past Project Documentation. See Section 500

ITEM	WHEN DUE	FROM	DOCUMENT TO BE SUBMITTED
13.	PRIOR TO PRE-CONSTRUCTION MEETING	LOW BIDDER	<ul style="list-style-type: none"> • Manufacturer Certification per Section 500-1.1.2.1
14.	WITHIN 10 WORKING DAYS AFTER RECEIPT BY BIDDER OF CONTRACT FORMS	APPARENT LOW BIDDER	Phased Funding Schedule Agreement (when required)
15.	WITHIN 10 WORKING DAYS AFTER RECEIPT BY BIDDER OF CONTRACT FORMS	APPARENT LOW BIDDER	Pre-Award Schedule (Phased Funded Contracts Only)
16.	WITHIN 10 WORKING DAYS AFTER RECEIPT BY BIDDER OF CONTRACT FORMS	APPARENT LOW BIDDER	Names of the principal individual owners of the Apparent Low Bidder
17.	WITHIN 10 WORKING DAYS AFTER RECEIPT BY BIDDER OF CONTRACT FORMS	APPARENT LOW BIDDER	If the Contractor is a Joint Venture: <ul style="list-style-type: none"> • Joint Venture Agreement • Joint Venture License
18.	WITHIN 10 WORKING DAYS AFTER RECEIPT BY BIDDER OF CONTRACT FORMS	APPARENT LOW BIDDER	Form BB05 - Work Force Report
19.	WITHIN 10 WORKING DAYS AFTER RECEIPT BY BIDDER OF CONTRACT FORMS	APPARENT LOW BIDDER	Contract Forms - Agreement
20.	WITHIN 10 WORKING DAYS AFTER RECEIPT BY BIDDER OF CONTRACT FORMS	APPARENT LOW BIDDER	Contract Forms - Payment and Performance Bond
21.	WITHIN 10 WORKING DAYS AFTER RECEIPT BY BIDDER OF CONTRACT FORMS	APPARENT LOW BIDDER	Certificates of Insurance and Endorsements
22.	WITHIN 10 WORKING DAYS AFTER RECEIPT BY BIDDER OF CONTRACT FORMS	APPARENT LOW BIDDER	Contractor Certification - Drug-Free Workplace
23.	WITHIN 10 WORKING DAYS AFTER RECEIPT BY BIDDER OF CONTRACT FORMS	APPARENT LOW BIDDER	Contractor Certification - American with Disabilities Act
24.	WITHIN 10 WORKING DAYS AFTER RECEIPT BY BIDDER OF CONTRACT FORMS	APPARENT LOW BIDDER	Contractors Standards - Pledge of Compliance

CONTRACT FORMS
AGREEMENT

CONTRACT FORMS

CONSTRUCTION CONTRACT

This contract is made and entered into between THE CITY OF SAN DIEGO, a municipal corporation, herein called "City", and ORTIZ CORPORATION, herein called "Contractor" for construction of **Sewer Group 691**; Bid No **K-15-5875-DBB-3-C**, in the amount of TWO MILLION THREE HUNDRED NINETY THOUSAND EIGHTY-THREE DOLLARS AND 04/100 (\$2,390,083.04), which is comprised of the Base Bid alone.

IN CONSIDERATION of the payments to be made hereunder and the mutual undertakings of the parties hereto, City and Contractor agree as follows:

1. The following are incorporated into this contract as though fully set forth herein:
 - (a) The attached Faithful Performance and Payment Bonds.
 - (b) The attached Proposal included in the Bid documents by the Contractor.
 - (c) Reference Standards listed in the Notice Inviting Bids and the Supplementary Special Provisions (SSP).
 - (d) Phased Funding Schedule Agreement and Long-term Revegetation Maintenance Agreement.
 - (e) That certain documents entitled **Sewer Group 691**, on file in the office of the Public Works Department as Document No. **B-00446**, as well as all matters referenced therein.
2. The Contractor shall perform and be bound by all the terms and conditions of this contract and in strict conformity therewith shall perform and complete in a good and workmanlike manner **Sewer Group 691**, Bid Number **K-15-5875-DBB-3-C**, San Diego, California.
3. For such performances, the City shall pay to Contractor the amounts set forth at the times and in the manner and with such additions or deductions as are provided for in this contract, and the Contractor shall accept such payment in full satisfaction of all claims incident to such performances.
4. No claim or suit whatsoever shall be made or brought by Contractor against any officer, agent, or employee of the City for or on account of anything done or omitted to be done in connection with this contract, nor shall any such officer, agent, or employee be liable hereunder.
5. This contract is effective as of the date that the Mayor or designee signs the agreement.

CONTRACT FORMS (continued)

IN WITNESS WHEREOF, this Agreement is signed by the City of San Diego, acting by and through its Mayor or designee, pursuant to Municipal Code §22.3102 authorizing such execution.

THE CITY OF SAN DIEGO

APPROVED AS TO FORM AND LEGALITY

By 

Jan I. Goldsmith, City Attorney
By 

W. Downs Prior
Principal Contract Specialist
Public Works Contracts

Print Name: Pedro De Cava, Jr.
Deputy City Attorney

Date: 11/25/14

Date: 11/25/14

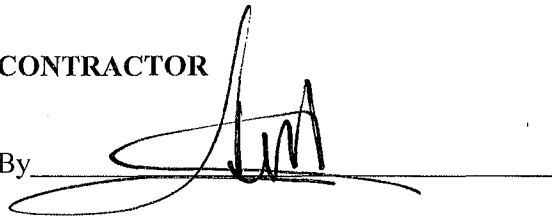
CONTRACTOR
By 

Print Name: AIDA BANGHART

Title: VICE PRESIDENT

Date: 10/09/2014

City of San Diego License No.: B1996008117

State Contractor's License No.: 602454

CONTRACT FORMS
ATTACHMENTS

**CONTRACT FORMS ATTACHMENTS
PERFORMANCE BOND AND LABOR AND MATERIALMEN'S BOND**

FAITHFUL PERFORMANCE BOND AND LABOR AND MATERIALMEN'S BOND:

ORTIZ CORPORATION, a corporation, as principal, and International Fidelity Insurance Company, a corporation authorized to do business in the State of California, as Surety, hereby obligate themselves, their successors and assigns, jointly and severally, to The City of San Diego a municipal corporation in the sum of TWO MILLION THREE HUNDRED NINETY THOUSAND EIGHTY-THREE DOLLARS AND 04/100 (\$2,390,083.04) for the faithful performance of the annexed contract, and in the sum of TWO MILLION THREE HUNDRED NINETY THOUSAND EIGHTY-THREE DOLLARS AND 04/100 (\$2,390,083.04) for the benefit of laborers and materialmen designated below.

Conditions:

If the Principal shall faithfully perform the annexed contract Sewer Group 691, Bid Number K-15-5875-DBB-3-C, San Diego, California then the obligation herein with respect to a faithful performance shall be void; otherwise it shall remain in full force.

If the Principal shall promptly pay all persons, firms and corporations furnishing materials for or performing labor in the execution of this contract, and shall pay all amounts due under the California Unemployment Insurance Act then the obligation herein with respect to laborers and materialmen shall be void; otherwise it shall remain in full force.

The obligation herein with respect to laborers and materialmen shall inure to the benefit of all persons, firms and corporations entitled to file claims under the provisions of Chapter 3 of Division 5 of Title I of the Government Code of the State of California or under the provisions of Section 3082 et seq. of the Civil Code of the State of California.

Changes in the terms of the annexed contract or specifications accompanying same or referred to therein shall not affect the Surety's obligation on this bond, and the Surety hereby waives notice of same.

CONTRACT ATTACHMENT (continued)
PERFORMANCE BOND AND LABOR AND MATERIALMEN'S BOND

The Surety shall pay reasonable attorney's fees should suit be brought to enforce the provisions of this bond.

Dated October 13, 2014

Approved as to Form and Legality

Ortiz Corporation
Principal

By

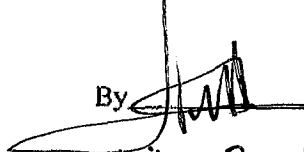
Aida Banghart - Vice President
Printed Name of Person Signing for Principal

Jan I. Goldsmith, City Attorney

By

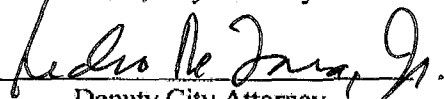
Deputy City Attorney

International Fidelity Insurance Company
Surety

By

Bart Stewart, Attorney-in-fact

Approved:

By:

W. Downs Prior
Principal Contract Specialist
Public Works Contracts

11/25/14

13400 Sabre Springs Parkway Ste. 245
Local Address of Surety

San Diego, CA 92128
Local Address (City, State) of Surety

(858) 513-1795
Local Telephone No. of Surety

Premium \$18,255

Bond No. SDIFSU 0641195

POWER OF ATTORNEY

INTERNATIONAL FIDELITY INSURANCE COMPANY ALLEGHENY CASUALTY COMPANY

ONE NEWARK CENTER, 20TH FLOOR NEWARK, NEW JERSEY 07102-5207

KNOW ALL MEN BY THESE PRESENTS: That INTERNATIONAL FIDELITY INSURANCE COMPANY, a corporation organized and existing under the laws of the State of New Jersey, and ALLEGHENY CASUALTY COMPANY, a corporation organized and existing under the laws of the State of Pennsylvania, having their principal office in the City of Newark, New Jersey, do hereby constitute and appoint

BART STEWART

Encinitas, CA.

their true and lawful attorney(s)-in-fact to execute, seal and deliver for and on its behalf as surety, any and all bonds and undertakings, contracts of indemnity and other writings obligatory in the nature thereof, which are or may be allowed, required or permitted by law, statute, rule, regulation, contract or otherwise, and the execution of such instrument(s) in pursuance of these presents, shall be as binding upon the said INTERNATIONAL FIDELITY INSURANCE COMPANY and ALLEGHENY CASUALTY COMPANY, as fully and amply, to all intents and purposes, as if the same had been duly executed and acknowledged by their regularly elected officers at their principal offices.

This Power of Attorney is executed and may be revoked, pursuant to and by authority of the By-Laws of INTERNATIONAL FIDELITY INSURANCE COMPANY and ALLEGHENY CASUALTY COMPANY and is granted under, and by authority of the following resolution adopted by the Board of Directors of INTERNATIONAL FIDELITY INSURANCE COMPANY at a meeting duly held on the 20th day of July, 2010 and by the Board of Directors of ALLEGHENY CASUALTY COMPANY at a meeting duly held on the 15th day of August, 2000:

"RESOLVED, that (1) the President, Vice President, or Secretary of the Corporation shall have the power to appoint, and to revoke the appointments of, Attorneys-in-Fact or agents with power and authority as defined or limited in their respective powers of attorney, and to execute on behalf of the Corporation and affix the Corporation's seal thereto; bonds; undertakings, recognizances, contracts of indemnity and other written obligations in the nature thereof or related thereto; and (2) any such Officers of the Corporation may appoint and revoke the appointments of joint-control custodians, agents for acceptance of process, and Attorneys-in-fact with authority to execute waivers and consents on behalf of the Corporation; and (3) the signature of any such Officer of the Corporation and the Corporation's seal may be affixed by facsimile to any power of attorney or certification given for the execution of any bond, undertaking, recognizance, contract of indemnity or other written obligation in the nature thereof or related thereto, such signature and seals when so used whether heretofore or hereafter, being hereby adopted by the Corporation as the original signature of such officer and the original seal of the Corporation, to be valid and binding upon the Corporation with the same force and effect as though manually affixed."

IN WITNESS WHEREOF, INTERNATIONAL FIDELITY INSURANCE COMPANY and ALLEGHENY CASUALTY COMPANY have each executed and attested these presents on this 12th day of March, 2012.

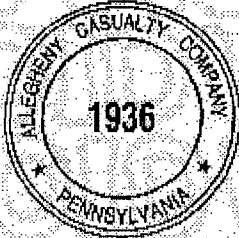

STATE OF NEW JERSEY
County of Essex

ROBERT W. MINSTER
Executive Vice President/Chief Operating Officer
(International Fidelity Insurance Company)
and President (Allegheny Casualty Company)

On this 12th day of March 2012, before me came the individual who executed the preceding instrument, to me personally known, and, being by me duly sworn, said he is the therein described and authorized officer of INTERNATIONAL FIDELITY INSURANCE COMPANY and ALLEGHENY CASUALTY COMPANY; that the seals affixed to said instrument are the Corporate Seals of said Companies; that the said Corporate Seals and his signature were duly affixed by order of the Boards of Directors of said Companies.

IN TESTIMONY WHEREOF, I have hereunto set my hand affixed my Official Seal, at the City of Newark, New Jersey the day and year first above written.

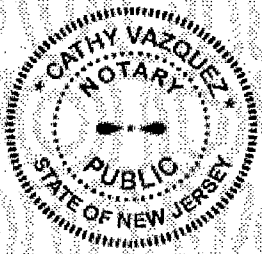

A NOTARY PUBLIC OF NEW JERSEY
My Commission Expires Mar. 27, 2014

CERTIFICATION

I, the undersigned officer of INTERNATIONAL FIDELITY INSURANCE COMPANY and ALLEGHENY CASUALTY COMPANY do hereby certify that I have compared the foregoing copy of the Power of Attorney and affidavit, and the copy of the Sections of the By-Laws of said Companies as set forth in said Power of Attorney, with the originals on file in the home office of said companies, and that the same are correct transcripts thereof, and of the whole of the said originals, and that the said Power of Attorney has not been revoked and is now in full force and effect.

IN TESTIMONY WHEREOF, I have hereunto set my hand this 13th day of October 2014

MARIA BRANCO, Assistant Secretary

CALIFORNIA ALL-PURPOSE CERTIFICATE OF ACKNOWLEDGMENT

State of California

County of San Diego

On 10/13/2014 before me, Brittany Aceves, Notary Public
(Here insert name and title of the officer)

personally appeared Bart Stewart

who proved to me on the basis of satisfactory evidence to be the person(s) whose name(s) is/are subscribed to the within instrument and acknowledged to me that he/~~she~~/they executed the same in his/~~her~~/their authorized capacity(ies), and that by his/~~her~~/their signature(s) on the instrument the person(s), or the entity upon behalf of which the person(s) acted, executed the instrument.

I certify under PENALTY OF PERJURY under the laws of the State of California that the foregoing paragraph is true and correct.

WITNESS my hand and official seal.

[Handwritten Signature]

Signature of Notary Public



(Notary Seal)

ADDITIONAL OPTIONAL INFORMATION

DESCRIPTION OF THE ATTACHED DOCUMENT	
_____ <small>(Title or description of attached document)</small>	
_____ <small>(Title or description of attached document continued)</small>	
Number of Pages _____	Document Date _____
_____ <small>(Additional information)</small>	

CAPACITY CLAIMED BY THE SIGNER	
<input type="checkbox"/> Individual (s)	
<input type="checkbox"/> Corporate Officer	
_____ <small>(Title)</small>	
<input type="checkbox"/> Partner(s)	
<input type="checkbox"/> Attorney-in-Fact	
<input type="checkbox"/> Trustee(s)	
<input type="checkbox"/> Other _____	

INSTRUCTIONS FOR COMPLETING THIS FORM

Any acknowledgment completed in California must contain verbiage exactly as appears above in the notary section or a separate acknowledgment form must be properly completed and attached to that document. The only exception is if a document is to be recorded outside of California. In such instances, any alternative acknowledgment verbiage as may be printed on such a document so long as the verbiage does not require the notary to do something that is illegal for a notary in California (i.e. certifying the authorized capacity of the signer). Please check the document carefully for proper notarial wording and attach this form if required.

- State and County information must be the State and County where the document signer(s) personally appeared before the notary public for acknowledgment.
- Date of notarization must be the date that the signer(s) personally appeared which must also be the same date the acknowledgment is completed.
- The notary public must print his or her name as it appears within his or her commission followed by a comma and then your title (notary public).
- Print the name(s) of document signer(s) who personally appear at the time of notarization.
- Indicate the correct singular or plural forms by crossing off incorrect forms (i.e. he/~~she~~/they-, is /are) or circling the correct forms. Failure to correctly indicate this information may lead to rejection of document recording.
- The notary seal impression must be clear and photographically reproducible. Impression must not cover text or lines. If seal impression smudges, re-seal if a sufficient area permits, otherwise complete a different acknowledgment form.
- Signature of the notary public must match the signature on file with the office of the county clerk.
 - ❖ Additional information is not required but could help to ensure this acknowledgment is not misused or attached to a different document.
 - ❖ Indicate title or type of attached document, number of pages and date.
 - ❖ Indicate the capacity claimed by the signer. If the claimed capacity is a corporate officer, indicate the title (i.e. CEO, CFO, Secretary).
- Securely attach this document to the signed document

CONTRACTOR CERTIFICATION

DRUG-FREE WORKPLACE

PROJECT TITLE: Sewer Group 691

I hereby certify that I am familiar with the requirements of San Diego City Council Policy No. 100-17 regarding Drug-Free Workplace as outlined in the WHITEBOOK, Section 7-13.3, "Drug-Free Workplace", of the project specifications, and that;

ORTIZ CORPORATION

(Name under which business is conducted)

has in place a drug-free workplace program that complies with said policy. I further certify that each subcontract agreement for this project contains language which indicates the subcontractor's agreement to abide by the provisions of subdivisions a) through c) of the policy as outlined.

Signed

Printed Name

AIDA BANGHART

Title

VICE PRESIDENT

CONTRACTOR CERTIFICATION

AMERICAN WITH DISABILITIES ACT (ADA) COMPLIANCE CERTIFICATION

PROJECT TITLE: Sewer Group 691

I hereby certify that I am familiar with the requirements of San Diego City Council Policy No. 100-4 regarding the American With Disabilities Act (ADA) outlined in the WHITEBOOK, Section 7-13.2, "American With Disabilities Act", of the project specifications, and that;

ORTIZ CORPORATION

(Name under which business is conducted)

has in place workplace program that complies with said policy. I further certify that each subcontract agreement for this project contains language which indicates the subcontractor's agreement to abide by the provisions of the policy as outlined.

Signed _____

Printed Name AIDA BANGHART

Title VICE PRESIDENT

CONTRACTOR CERTIFICATION

CONTRACTOR STANDARDS – PLEDGE OF COMPLIANCE

PROJECT TITLE: Sewer Group 691

I declare under penalty of perjury that I am authorized to make this certification on behalf of ORTIZ CORPORATION, as Contractor, that I am familiar with the requirements of City of San Diego Municipal Code § 22.3224 regarding Contractor Standards as outlined in the WHITEBOOK, Section 7-13.4, ("Contractor Standards"), of the project specifications, and that Contractor has complied with those requirements.

I further certify that each of the Contractor's subcontractors whose subcontracts are greater than \$50,000 in value has completed a Pledge of Compliance attesting under penalty of perjury of having complied with City of San Diego Municipal Code § 22.3224.

Dated this 9th Day of OCTOBER, 2014.

Signed  _____

Printed Name AIDA BAUGHART

Title VICE PRESIDENT

AFFIDAVIT OF DISPOSAL

WHEREAS, on the _____ DAY OF _____, _____, the undersigned entered into and executed a contract with the City of San Diego, a municipal corporation, for:

Sewer Group 691

(Name of Project)

as particularly described in said contract and identified as Bid No. **K-15-5875-DBB-3-C**; SAP No. (WBS/IO/CC) **B-00446** and **WHEREAS**, the specification of said contract requires the Contractor to affirm that "all brush, trash, debris, and surplus materials resulting from this project have been disposed of in a legal manner"; and **WHEREAS**, said contract has been completed and all surplus materials disposed of:

NOW, THEREFORE, in consideration of the final payment by the City of San Diego to said Contractor under the terms of said contract, the undersigned Contractor, does hereby affirm that all surplus materials as described in said contract have been disposed of at the following location(s)

and that they have been disposed of according to all applicable laws and regulations.

Dated this _____ DAY OF _____, _____.

by _____ Contractor

ATTEST:

State of _____
County of _____

On this _____ DAY OF _____, 2____, before the undersigned, a Notary Public in and for said County and State, duly commissioned and sworn, personally appeared _____ known to me to be the _____ Contractor named in the foregoing Release, and whose name is subscribed thereto, and acknowledged to me that said Contractor executed the said Release.

Notary Public in and for said County and State

ATTACHMENTS

ATTACHMENT A
SCOPE OF WORK

SCOPE OF WORK

1. **SCOPE OF WORK:** The Work involves furnishing all labor, materials, equipment, services, and other incidental works and appurtenances for the construction of the Project as described below:

The project proposes to replace an existing sewer main approximately 4,360 linear feet (LF) of pipe as follows: 3,917 LF of open cut (8-inch pipe), 62 LF of pipe bursting (8-inch pipe) within Balboa Municipal Golf Course, and rehabilitation of approximately 381 LF of 6 and 8-inch pipe within Balboa Park Municipal Golf Course and Switzer Canyon Park. The work also includes the abandonment of approximately 2,935 LF of existing sewer main located on canyon and ROW, and replumb of approximately 36 sewer laterals.

- 1.1. The Work shall be performed in accordance with:

1.1.1. This Notice Inviting Bids and Plans numbered **32506-01-D** through **32506-22-D**, inclusive.

2. **CONSTRUCTION COST:** The City's estimated construction cost for this contract is **\$2,614,000**.
3. **LOCATION OF WORK:** See the Location Map.
4. **CONTRACT TIME:** The Contract Time for completion of the Work shall be **120 Working Days**.
5. **CONTRACTOR'S LICENSE CLASSIFICATION:** In accordance with the provisions of California Law, the Contractor shall possess valid appropriate license(s) at the time that the Bid is submitted. Failure to possess the specified license(s) shall render the Bid as **non-responsive** and shall act as a bar to award of the Contract to any Bidder not possessing required license(s) at the time of Bid.

- 5.1. The City has determined the following licensing classifications for this contract:

Option	Classifications
1	CLASS A
2	CLASS C34
3	CLASS C42

- 5.2. The Bidder shall satisfy the licensing requirement by meeting **at least** one of the listed options.

ATTACHMENT B
PHASED FUNDING PROVISIONS

PHASED FUNDING PROVISIONS

1. PHASED FUNDING:

- 1.1. For phased funded contracts, the City typically secures enough funds for the first 90 days of the contract prior to award. Within 10 Working Days after Bid opening date the Apparent Low Bidder must contact the Project Manager to discuss fund availability and the duration of the first phase and submit the Pre-Award Schedule to the City for approval and preparation of the first Phased Funding Schedule Agreement.
- 1.2. The Apparent Low Bidder will be required to provide a Pre-award Schedule in accordance with 6-1, "CONSTRUCTION SCHEDULE AND COMMENCEMENT OF THE WORK" and 9-3, "PAYMENT" prior to award of Contract.
- 1.3. If the Bid submitted by the Apparent Low Bidder is rejected by the City for any reason, then within 5 Working Days after receiving notice, the next Apparent Low Bidder must provide the Pre-Award Schedule. This process will continue until the City has selected the Apparent Low Bidder or have decided to reject all Bids.
- 1.4. The first Phased Funding Schedule Agreement must show the fund availability for the first phase. Within 22 Working Days from the date of the Bid Opening or notice to the next Apparent Low Bidder (whichever occurs last) and once a Pre-Award Schedule is accepted by the City, the City will present the first Phased Funding Schedule Agreement to you when you are selected as the Apparent Low Bidder as defined in the City's Municipal Code, §22.3003.
- 1.5. At the City's request, you must meet with the City's project manager before execution of the first Phased Funding Schedule Agreement to discuss his or her comments and requests for revision to the Pre-Award Schedule.
- 1.6. Your failure to perform the following may result in the Bid being rejected as **non-responsive**:
 1. meet with the City's project manager, if requested to do so, to discuss and respond to the City's comments regarding the Pre-Award Schedule,
 2. revise the Pre-Award Schedule as requested by the City within the specified 22 Working Days timeframe, or
 3. execute the first Phased Funding Schedule Agreement within a day after receipt.

PHASED FUNDING SCHEDULE AGREEMENT

Check one:

- First Phased Funding Schedule Agreement
- Final Phased Funding Schedule Agreement

BID NUMBER: K-15-5875-DBB-3-C

CONTRACT OR TASK TITLE: SEWER GROUP 691

CONTRACTOR: ORTIZ CORPORATION

Funding Phase	Phase Description	Phase Start	Phase Finish	Not-to-Exceed Amount
1	Replace 4360 LF of sewer main. The work also includes replumbing sewer laterals, manhole replacement, sewer main rehab, manhole rehab, the abandonment of 2935 LF of existing sewer mains, curb ramps and street resurfacing. (Sheets 32506-01-D thru 32506-21-D)	03/2015	09/2015	\$2,390,083.04
Total				\$2,390,083.04

Notes:

- (1) City Supplement 9-3.6, "PHASED FUNDING COMPENSATION" applies.
- (2) The total of all funding phases shall be equal to the TOTAL BID PRICE as shown on BID SCHEDULE 1 - PRICES.
- (3) This PHASED FUNDING SCHEDULE AGREEMENT will be incorporated into the CONTRACT and shall only be revised by a written modification to the CONTRACT.

CITY OF SAN DIEGO

By: 
 Name: JERICHO GALLARDO
 Project Manager

Department Name: PUBLIC WORKS

Date: 10/23/2014

CONTRACTOR

By: 
 Name: Marcelino E. Ortiz

Title: President

Date: October 22, 2014

-END OF PHASED FUNDING SCHEDULE AGREEMENT-

ATTACHMENT C
EQUAL OPPORTUNITY CONTRACTING PROGRAM

EQUAL OPPORTUNITY CONTRACTING PROGRAM

1. To The WHITEBOOK, Chapter 10, Sections D and E, DELETE each in its entirety, and SUBSTITUTE with the following:

D. CITY'S EQUAL OPPORTUNITY COMMITMENT.

1. Nondiscrimination in Contracting Ordinance.

1. The Contractor, Subcontractors and Suppliers shall comply with requirements of the City's Nondiscrimination in Contracting Ordinance, San Diego Municipal Code §§22.3501 through 22.3517.

The Contractor shall not discriminate on the basis of race, gender, religion, national origin, ethnicity, sexual orientation, age, or disability in the solicitation, selection, hiring, or treatment of subcontractors, vendors, or suppliers. The Contractor shall provide equal opportunity for subcontractors to participate in subcontracting opportunities. The Contractor understands and agrees that violation of this clause shall be considered a material breach of the contract and may result in contract termination, debarment, or other sanctions.

The Contractor shall include the foregoing clause in all contracts between the Contractor and Subcontractors and Suppliers.

2. Disclosure of Discrimination Complaints. As part of its Bid or Proposal, the Bidder shall provide to the City a list of all instances within the past 10 years where a complaint was filed or pending against Bidder in a legal or administrative proceeding alleging that Bidder discriminated against its employees, subcontractors, vendors, or suppliers, and a description of the status or resolution of that complaint, including any remedial action taken.
3. Upon the City's request, the Contractor agrees to provide to the City, within 60 days, a truthful and complete list of the names of all Subcontractors and Suppliers that the Contractor has used in the past 5 years on any of its contracts that were undertaken within San Diego County, including the total dollar amount paid by the Contractor for each subcontract or supply contract.
4. The Contractor further agrees to fully cooperate in any investigation conducted by the City pursuant to the City's Nondiscrimination in Contracting Ordinance, Municipal Code §§22.3501 through 22.3517. The Contractor understands and agrees that violation of this clause shall be considered a material breach of the Contract and may result in remedies being ordered against the Contractor up to and including contract termination, debarment and other sanctions for violation of the provisions of the Nondiscrimination in Contracting Ordinance. The Contractor further understands and agrees that the procedures, remedies and sanctions provided for in the Nondiscrimination in Contracting Ordinance apply only to violations of the Ordinance.

E. EQUAL EMPLOYMENT OPPORTUNITY OUTREACH PROGRAM.

1. The Contractor, Subcontractors and Suppliers shall comply with the City's Equal Employment Opportunity Outreach Program, San Diego Municipal Code §§22.2701 through 22.2707.

The Contractor shall not discriminate against any employee or applicant for employment on any basis prohibited by law. Contractor shall provide equal opportunity in all employment practices. Prime Contractor shall ensure their subcontractors comply with this program. Nothing in this section shall be interpreted to hold a prime contractor liable for any discriminatory practice of its subcontractors.

The Contractor shall include the foregoing clause in all contracts between the Contractor and Subcontractors and Suppliers.

2. If the Contract is competitively solicited, the selected Bidder shall submit a Work Force Report (Form BB05), within 10 Working Days after receipt by the Bidder of Contract forms to the City for approval as specified in the Notice of Intent to Award letter from the City.
3. If a Work Force Report is submitted, and the City determines there are under-representations when compared to County Labor Force Availability data, the selected Bidder shall submit an Equal Employment Opportunity Plan.
4. If the selected Bidder submits an Equal Employment Opportunity Plan, it shall include the following assurances:
 1. The Contractor shall maintain a working environment free of discrimination, harassment, intimidation and coercion at all sites and in all facilities at which the Contractor's employees are assigned to work.
 2. The Contractor reviews its EEO Policy, at least annually, with all on-site supervisors involved in employment decisions.
 3. The Contractor disseminates and reviews its EEO Policy with all employees at least once a year, posts the policy statement and EEO posters on all company bulletin boards and job sites, and documents every dissemination, review and posting with a written record to identify the time, place, employees present, subject matter, and disposition of meetings.
 4. The Contractor reviews, at least annually, all supervisors' adherence to and performance under the EEO Policy and maintains written documentation of these reviews.
 5. The Contractor discusses its EEO Policy Statement with subcontractors with whom it anticipates doing business, includes the EEO Policy Statement in its subcontracts, and provides such documentation to the City upon request.

6. The Contractor documents and maintains a record of all bid solicitations and outreach efforts to and from subcontractors, contractor associations and other business associations.
7. The Contractor disseminates its EEO Policy externally through various media, including the media of people of color and women, in advertisements to recruit, maintains files documenting these efforts, and provides copies of these advertisements to the City upon request.
8. The Contractor disseminates its EEO Policy to union and community organizations.
9. The Contractor provides immediate written notification to the City when any union referral process has impeded the Contractor's efforts to maintain its EEO Policy.
10. The Contractor maintains a current list of recruitment sources, including those outreaching to people of color and women, and provides written notification of employment opportunities to these recruitment sources with a record of the organizations' responses.
11. The Contractor maintains a current file of names, addresses and phone numbers of each walk-in applicant, including people of color and women, and referrals from unions, recruitment sources, or community organizations with a description of the employment action taken.
12. The Contractor encourages all present employees, including people of color and women employees, to recruit others.
13. The Contractor maintains all employment selection process information with records of all tests and other selection criteria.
14. The Contractor develops and maintains documentation for on-the-job training opportunities, participates in training programs, or both for all of its employees, including people of color and women, and establishes apprenticeship, trainee, and upgrade programs relevant to the Contractor's employment needs.
15. The Contractor conducts, at least annually, an inventory and evaluation of all employees for promotional opportunities and encourages all employees to seek and prepare appropriately for such opportunities.
16. The Contractor ensures the company's working environment and activities are non-segregated except for providing separate or single-user toilets and necessary changing facilities to assure privacy between the sexes.

ATTACHMENT D
INTENTIONALLY LEFT BLANK

ATTACHMENT E
SUPPLEMENTARY SPECIAL PROVISIONS

SUPPLEMENTARY SPECIAL PROVISIONS

The following Supplementary Special Provisions (SSP) modifies the following documents:

- 1) Standard Specifications for Public Works Construction (The GREENBOOK) currently in effect.
 - 2) The City of San Diego Standard Specifications for Public Works Construction (The WHITEBOOK).
-

SECTION 1 – TERMS, DEFINITIONS, ABBREVIATIONS, UNITS OF MEASURE, AND SYMBOLS

1-2 TERMS AND DEFINITIONS.

Normal Working Hours. To the City Supplement, ADD the following:

The Normal Working Hours are **8:30 AM to 3:30 PM.**

SECTION 2 - SCOPE AND CONTROL OF WORK

2-3.2 Self Performance. DELETE in its entirety and SUBSTITUTE with the following:

1. You must perform, with your own organization, Contract work amounting to at least 50% of the base bid alone or base bid and any additive or deductive alternate(s) that together when added or deducted form the basis of award.
2. The self performance percentage requirement will be waived for contracts when a “B” License is required or allowed.

2-5.3.1 General. To the City Supplement, ADD the following

7. For products for which an AML is available, products listed in the AML shall be used. A submittal review will be conducted for products not identified on an AML on a case-by-case basis when:
 - a) The product type or category is not in the AML.
 - b) The AML does not list at least two available manufacturers of the product.
 - c) The material or manufacturer listed in the AML is no longer available. Documentation to substantiate the product is no longer available or in production is required as part of the submittal.

In the case of conducting a submittal review when required by the Plans or Special Provisions, or when requested by the Engineer, all submittals shall be accompanied by the City's submittal form.

The Product Submittal Form is available for download at:

<http://www.sandiego.gov/publicworks/edocref/index.shtml>

2-11.1.1 General. To the City Supplement, item 2, ADD the following:

Time lapse video robotic cameras must provide a clear view of backfill and compaction operations. When this is not possible if camera is mounted on excavator, camera must be mounted on a portable tower or similar device and repositioned as Work progresses.

2-14.3 Coordination. To the City Supplement, ADD the following:

Other adjacent City project is scheduled for construction for the same time period. See Appendix "I" for approximate location. Coordinate the Work with the adjacent project as listed:

- a) Sewer and Water Group 695, Mahmoud Oriqat, Project Manager (619) 533-5232.

SECTION 4 - CONTROL OF MATERIALS

4-1.6 Trade Names or Equals. ADD the following:

You must submit your list of proposed substitutions for "an equal" ("or equal") item(s) **no less than 15 Working Days prior to Bid due date** and on the City's Product Submittal Form available at.

<http://www.sandiego.gov/publicworks/edocref/index.shtml>

SECTION 6 - PROSECUTION, PROGRESS AND ACCEPTANCE OF WORK

6-7.1 General. To the City Supplement, ADD the following:

5. For Water projects where shutdowns of 16 inch and larger pipes are required, there is a shutdown moratorium from May until October. Contractor shall plan and schedule work accordingly. No additional payment or working days will be granted for delays due to this moratorium.
6. 30 Working days for full depth asphalt final mill and resurfacing work required per SDG-107.

SECTION 7 - RESPONSIBILITIES OF THE CONTRACTOR

7-3 **LIABILITY INSURANCE.** DELETE in its entirety and SUBSTITUTE with the following:

The insurance provisions herein must not be construed to limit your indemnity obligations contained in the Contract.

7-3.1 **Policies and Procedures.**

1. You must procure the insurance described below, at its sole cost and expense, to provide coverage against claims for loss including injuries to persons or damage to property, which may arise out of or in connection with the performance of the Work by you, your agents, representatives, officers, employees or Subcontractors.
2. Insurance coverage for property damage resulting from your operations is on a replacement cost valuation. The market value will not be accepted.
3. You must maintain this insurance for the duration of this contract and at all times thereafter when you are correcting, removing, or replacing Work in accordance with this contract. Your liabilities under the Contract, e.g., your indemnity obligations, is not deemed limited to the insurance coverage required by this contract.
4. Payment for insurance is included in the various items of Work as bid by you, and except as specifically agreed to by the City in writing, you are not entitled to any additional payment. Do not begin any work under this contract until you have provided and the City has approved all required insurance.
5. Policies of insurance must provide that the City is entitled to 30 days (10 days for cancellation due to non-payment of premium) prior written notice of cancellation or non-renewal of the policy. Maintenance of specified insurance coverage is a material element of the Contract. Your failure to maintain or renew coverage or to provide evidence of renewal during the term of the Contract may be treated by the City as a material breach of the Contract.

7-3.2 **Types of Insurance.**

7-3.2.1 **Commercial General Liability Insurance.**

1. Commercial General Liability Insurance must be written on the current version of the ISO Occurrence form CG 00 01 07 98 or an equivalent form providing coverage at least as broad.
2. The policy must cover liability arising from premises and operations, XCU (explosions, underground, and collapse), independent contractors, products/completed operations, personal injury and advertising injury, bodily injury, property damage, and liability assumed under an insured's contract (including the tort liability of another assumed in a business contract).

3. There must be no endorsement or modification limiting the scope of coverage for either “insured vs. insured” claims or contractual liability. You must maintain the same or equivalent insurance for at least 10 years following completion of the Work.
4. All costs of defense must be outside the policy limits. Policy coverage must be in liability limits of not less than the following:

<u>General Annual Aggregate Limit</u>	<u>Limits of Liability</u>
Other than Products/Completed Operations	\$2,000,000
Products/Completed Operations Aggregate Limit	\$2,000,000
Personal Injury Limit	\$1,000,000
Each Occurrence	\$1,000,000

7-3.2.2 Commercial Automobile Liability Insurance.

1. You must provide a policy or policies of Commercial Automobile Liability Insurance written on the current version of the ISO form CA 00 01 12 90 or later version or equivalent form providing coverage at least as broad in the amount of \$1,000,000 combined single limit per accident, covering bodily injury and property damage for owned, non-owned, and hired automobiles (“Any Auto”).
2. All costs of defense must be outside the limits of the policy.

7-3.2.3 Contractors Pollution Liability Insurance.

1. You must procure and maintain at your expense or require Subcontractor, as described below to procure and maintain, the Contractors Pollution Liability Insurance including contractual liability coverage to cover liability arising out of cleanup, removal, storage, or handling of hazardous or toxic chemicals, materials, substances, or any other pollutants by you or any Subcontractor in an amount not less than \$2,000,000 limit for bodily injury and property damage.
2. All costs of defense must be outside the limits of the policy. Any such insurance provided by Subcontractor instead of you must be approved separately in writing by the City.
3. For approval of a substitution of Subcontractor’s insurance, you must certify that all activities for which the Contractors Pollution Liability Insurance will provide coverage will be performed exclusively by the Subcontractor providing the insurance. The deductible must not exceed \$25,000 per claim.
4. Contractual liability must include coverage of tort liability of another party to pay for bodily injury or property damage to a third person or organization. There must be no endorsement or modification of the coverage limiting the scope of coverage for either “insured vs. insured” claims or contractual liability.
5. Occurrence based policies must be procured before the Work commences and must be maintained for the Contract Time. Claims Made policies must be procured before the Work commences, must be maintained for the Contract Time, and must include a 12 month extended Claims Discovery Period applicable to this contract

or the existing policy or policies must continue to be maintained for 12 months after the completion of the Work without advancing the retroactive date.

6. Except as provided for under California law, the policy or policies must provide that the City is entitled to 30 days prior written notice (10 days for cancellation due to non-payment of premium) of cancellation or non-renewal of the policy or policies.

7-3.3 Rating Requirements. Except for the State Compensation Insurance Fund, all insurance required by this contract as described herein must be carried only by responsible insurance companies with a rating of, or equivalent to, at least “A-, VI” by A.M. Best Company, that are authorized by the California Insurance Commissioner to do business in the State, and that have been approved by the City.

7-3.3.1 Non-Admitted Carriers. The City will accept insurance provided by non-admitted, “surplus lines” carriers only if the carrier is authorized to do business in the State and is included on the List of Approved Surplus Lines Insurers (LASLI list).

All policies of insurance carried by non-admitted carriers must be subject to all of the requirements for policies of insurance provided by admitted carriers described herein.

7-3.4 Evidence of Insurance. Furnish to the City documents e.g., certificates of insurance and endorsements evidencing the insurance required herein, and furnish renewal documentation prior to expiration of this insurance. Each required document must be signed by the insurer or a person authorized by the insurer to bind coverage on its behalf. We reserve the right to require complete, certified copies of all insurance policies required herein.

7-3.5 Policy Endorsements.

7-3.5.1 Commercial General Liability Insurance.

7-3.5.1.1 Additional Insured.

- a) You must provide at your expense policy endorsement written on the current version of the ISO Occurrence form CG 20 10 11 85 or an equivalent form providing coverage at least as broad.
- b) To the fullest extent allowed by law e.g., California Insurance Code §11580.04, the policy must be endorsed to include the City and its respective elected officials, officers, employees, agents, and representatives as additional insured.
- c) The additional insured coverage for projects for which the Engineer’s Estimate is \$1,000,000 or more must include liability arising out of: (a) Ongoing operations performed by you or on your behalf, (b) your products, (c) your work, e.g., your completed operations performed by you or on your behalf, or (d) premises owned, leased, controlled, or used by you.

- d) The additional insured coverage for projects for which the Engineer's Estimate is less than \$1,000,000 must include liability arising out of: (a) Ongoing operations performed by you or on your behalf, (b) your products, or (c) premises owned, leased, controlled, or used by you.

7-3.5.1.2 Primary and Non-Contributory Coverage. The policy must be endorsed to provide that the coverage with respect to operations, including the completed operations, if appropriate, of the Named Insured is primary to any insurance or self-insurance of the City and its elected officials, officers, employees, agents and representatives. Further, it must provide that any insurance maintained by the City and its elected officials, officers, employees, agents and representatives must be in excess of your insurance and must not contribute to it.

7-3.5.1.3 Project General Aggregate Limit. The policy or policies must be endorsed to provide a Designated Construction Project General Aggregate Limit that will apply only to the Work. Only claims payments which arise from the Work must reduce the Designated Construction Project General Aggregate Limit. The Designated Construction Project General Aggregate Limit must be in addition to the aggregate limit provided for the products-completed operations hazard.

7-3.5.2 Commercial Automobile Liability Insurance.

7-3.5.2.1 Additional Insured. Unless the policy or policies of Commercial Auto Liability Insurance are written on an ISO form CA 00 01 12 90 or a later version of this form or equivalent form providing coverage at least as broad, the policy must be endorsed to include the City and its respective elected officials, officers, employees, agents, and representatives as additional insured, with respect to liability arising out of automobiles owned, leased, hired or borrowed by you or on your behalf. This endorsement is limited to the obligations permitted by California Insurance Code §11580.04.

7-3.5.3 Contractors Pollution Liability Insurance Endorsements.

7-3.5.3.1 Additional Insured.

- a) The policy or policies must be endorsed to include as an Insured the City and its respective elected officials, officers, employees, agents, and representatives, with respect to liability arising out of: (a) Ongoing operations performed by you or on your behalf, (b) your products, (c) your work, e.g., your completed operations performed by you or on your behalf, or (d) premises owned, leased, controlled, or used by you; except that in connection with, collateral to, or affecting any construction contract to which the provisions of subdivision (b) of § 2782 of the California Civil Code apply, this endorsement must not provide any duty of indemnity coverage for the active negligence of the City and its respective elected officials, officers, employees, agents, and representatives in any case where an agreement to indemnify the City and its respective elected officials, officers, employees, agents, and representatives would be invalid under subdivision (b) of §2782 of the California Civil Code.
- b) In any case where a claim or loss encompasses the negligence of the Insured and the active negligence of the City and its respective elected officials, officers, employees, agents, and representatives that is not covered because of California

Insurance Code §11580.04, the insurer's obligation to the City and its respective elected officials, officers, employees, agents, and representatives must be limited to obligations permitted by California Insurance Code §11580.04.

7-3.5.3.2 Primary and Non-Contributory Coverage. The policy or policies must be endorsed to provide that the insurance afforded by the Contractors Pollution Liability Insurance policy or policies is primary to any insurance or self-insurance of the City and its elected officials, officers, employees, agents and representatives with respect to operations including the completed operations of the Named Insured. Any insurance maintained by the City and its elected officials, officers, employees, agents and representatives must be in excess of your insurance and must not contribute to it.

7-3.5.3.3 Severability of Interest. For Contractors Pollution Liability Insurance, the policy or policies must provide that your insurance must apply separately to each insured against whom claim is made or suit is brought, except with respect to the limits of the insurer's liability and must provide cross-liability coverage.

7-3.6 Deductibles and Self-Insured Retentions. You must pay for all deductibles and self-insured retentions. You must disclose deductibles and self-insured retentions to the City at the time the evidence of insurance is provided.

7-3.7 Reservation of Rights. The City reserves the right, from time to time, to review your insurance coverage, limits, deductibles and self-insured retentions to determine if they are acceptable to the City. The City will reimburse you, without overhead, profit, or any other markup, for the cost of additional premium for any coverage requested by the Engineer but not required by this contract.

7-3.8 Notice of Changes to Insurance. You must notify the City 30 days prior to any material change to the policies of insurance provided under this contract.

7-3.9 Excess Insurance. Policies providing excess coverage must follow the form of the primary policy or policies e.g., all endorsements.

7-4 WORKERS' COMPENSATION INSURANCE. DELETE in its entirety and SUBSTITUTE with the following:

7-4.1 Workers' Compensation Insurance and Employers Liability Insurance.

1. In accordance with the provisions of §3700 of the California Labor Code, you must provide at your expense Workers' Compensation Insurance and Employers Liability Insurance to protect you against all claims under applicable state workers compensation laws. The City, its elected officials, and employees will not be responsible for any claims in law or equity occasioned by your failure to comply with the requirements of this section.
2. Limits for this insurance must be not less than the following:

<u>Workers' Compensation</u>	<u>Statutory Employers Liability</u>
Bodily Injury by Accident	\$1,000,000 each accident
Bodily Injury by Disease	\$1,000,000 each employee
Bodily Injury by Disease	\$1,000,000 policy limit

3. By signing and returning the Contract you certify that you are aware of the provisions of §3700 of the Labor Code which require every employer to be insured against liability for worker's compensation or to undertake self-insurance in accordance with the provisions of that code and you must comply with such provisions before commencing the Work as required by §1861 of the California Labor Code.

7-4.1.1 Waiver of Subrogation. The policy or policies must be endorsed to provide that the insurer will waive all rights of subrogation against the City, and its respective elected officials, officers, employees, agents, and representatives for losses paid under the terms of the policy or policies and which arise from work performed by the Named Insured for the City.

7-5 PERMITS, FEES, AND NOTICES. To the City Supplement, ADD the following:

The City will obtain, at no cost to the Contractor; the following permits:

1. Site Development Permit.

7-10.5.3 Steel Plate Covers. Table 7-10.5.3(A), REVISE the plate thickness for 5'-3" trench width to read 1 3/4".

7-15 INDEMNIFICATION AND HOLD HARMLESS AGREEMENT. To the City Supplement, fourth paragraph, last sentence, DELETE in its entirety and SUBSTITUTE with the following:

Your duty to indemnify and hold harmless does not include any claims or liability arising from the established active or sole negligence, or willful misconduct of the City, its officers, or employees.

7-16 COMMUNITY LIASON. To the City Supplement, DELETE in its entirety and SUSBTITUTE with the following:

ADD:

7-16 COMMUNITY OUTREACH.

7-16.1 General.

1. To ensure consistency with the City's community outreach plan for the project, the City will work with the Contractor to inform the public (which includes, but is not limited to, property owners, renters, homeowners, business owners, recreational users, and other community members and stakeholders) of construction impacts. Efforts by the Contractor to mitigate construction impacts by communicating with the public require close coordination and cooperation with the City.
2. The Contractor will perform the community outreach activities required throughout the Contract Time.
3. The Contractor shall closely coordinate the Work with the businesses, institutions, residents and property owners impacted by the Project. Example duties of the Contractor include notification to the businesses, institutions

and residents of the commencement of construction activities not less than 5 days in advance, coordination of access for vehicular and pedestrian traffic to businesses, institutions and residences impacted by the Project, reporting of Contractor activities at all Project progress meetings scheduled by the Engineer, attendance to the Project Pre-construction Meeting, attendance at 2 community meetings, response to community questions and complaints related to Contractor activities, and written documentation including logging in all inquiries and complaints received into the City's Public Contact Log located on the City's SDSHare site:

<http://sdshare/forums/ecp/PITS/picr/Lists/Public%20Contact%20Log/AllItems.aspx>

4. The Contractor shall execute the Information Security Policy Acknowledgement Form - For Non-City Employees within 15 days of the award of the Contract if:
 - a) The contact information for the Contractor is made available on any outreach materials or;
 - b) The Contractor will be the primary point of contact to resolve project related inquiries and complaints.

5. Electronic Communication.

All inquiries and complaints will be logged in to the City's SDSHare site within 24 hours of receipt of inquiries and complaints.

Any updates or a resolution of inquiries, and complaints shall be documented in the City's SDSHare site within 24 hours.

Copies of email communications shall be saved on to the City's SDSHare site as individually as an Outlook Message Format (*.msg).

All graphics, photos, and other electronic files associated with the inquiries and or complaints shall be saved into the individual record.

6. **When specified in the Special Provisions**, present your Exclusive Community Liaison to the Engineer, in writing, within 15 days of the award of the Contract.

7-16.2 Submittals.

1. The Contractor shall submit to the Resident Engineer, for review and approval, all drafts of letters, notices, postcards, door hangers, signs, mailing lists, proposed addresses for hand-delivery, and any other notices and letters that are to be mailed and or distributed to the public.
 - a. Prior to distributing or mailing, the Contractor shall submit final drafts of letters, notices, postcards, door hangers, signs, and any

other notices and letters to the Resident Engineer for final review and approval.

- b. After distributing or mailing, the Contractor shall submit verification of delivery and any copies of returned notices to the Resident Engineer.
2. The Contractor will use the City's SDSShare site to identify and summarize communications (via phone, in person, and email) with the public the within 24 hours of receipt, even if the Contractor's response to the individual is still incomplete. The Contractor will upload to the City's SDSShare site copies of all written, electronic, and verbal communications and conversations with the public.

7-16.3 Public Notice by Contractor.

1. Furnish and distribute public notices in the form of door hangers using the City's format to all occupants and/or property owners along streets where Work is to be performed at least 5 days before starting the Work as directed by the Resident Engineer.
2. For all Work on private property, contact each owner and occupant individually a minimum of 15 days prior to the Work. If the Work has been delayed, re-notify owners and occupants of the new Work schedule, as directed by the Resident Engineer.

7-16.4 Quality Assurance.

1. During the course of community outreach, the Contractor shall ensure the character of all persons that conduct community outreach (distributing door hangers, attending community meetings, interacting with the public, etc.), on behalf of the Contractor:
 - a. Have the ability to speak and comprehend English and/or Spanish, as appropriate for the community or public they are informing,
 - b. Possess and display easily verifiable and readable personal identification that identifies the person as an employee of the Contractor,
 - c. Have the interpersonal skills to effectively, professionally, and tactfully represent the project, Contractor, and City to the public.

7-16.5 Communications with the Public.

1. The Contractor shall provide updates on construction impacts to the Resident Engineer. The Contractor shall notify the Resident Engineer in advance about time-sensitive construction impacts and may be required to distribute construction impact notices to the public on short notice.

2. The Contractor shall incorporate community outreach activities related to construction impacts in the baseline schedule and update the Resident Engineer with each week's submittal of the Three-Week Look Ahead Schedule.
3. At the request of the Resident Engineer, the Contractor shall attend and participate in project briefings at community meetings.
4. The Contractor shall coordinate with the Resident Engineer on all responses and actions taken to address public inquiries and complaints within 24-hours that they are received.

7-16.6 Communications with Media.

1. The City may allow members of the media access to its construction site(s) on a case-by-case basis only.
2. Occasionally, members of the media may show up at construction sites, uninvited. Members of the media (including, but not limited to newspaper, magazine, radio, television, bloggers, and videographers) do not have the legal right to be in the construction site without the City's permission.
3. In the event media representatives arrive near or on the construction site(s), the Contractor shall keep them off the site(s), in a courteous and professional manner, until a Public Information Officer is available to meet them at an approved location.
4. The Contractor shall report all members of the media visits to the Resident Engineer as quickly as possible, so that the City's Public Information Officer can meet with the members of the media at the construction site(s).
5. If the City allows members of the media to access a construction site, the Contractor shall allow the City to escort the media representatives while they are on the construction site and shall ensure their safety.
6. The Contractor shall require media representatives to sign in and out of the Site Visitor Log and to use Personal Protective Equipment.
7. The Contractor has a right to speak to members of the media about its company and its role on the project. All other questions shall be referred to the City.

7-16.7 Exclusive Community Liaison Services.

If directed to conduct Exclusive Community Liaison Services, the Contractor shall retain an Exclusive Community Liaison for the Project whose sole responsibilities will be as follows:

1. Develop a contact list of community, tenants, property owners, and agencies with a stake in the project.

2. Notify businesses, institutions, property owners, and residents of the commencement of construction activities and utility service interruptions not less than 5 days in advance.
3. Coordinate access for vehicular and pedestrian traffic to businesses, institutions and residences impacted by the Project.
4. Prepare and present of materials in coordination with the Resident Engineer (the City's standards and guidelines for the communication materials are available for review by Bidders by sending a request to the Contract Specialist).
5. Respond to community questions and complaints related to Contractor activities.
6. Write, edit, update, or produce brochures, pamphlets and news releases.
7. Provide standard telephone inquiries and e-mail responses:
 - a) Respond to telephone calls and e-mails from the public.
 - b) Record calls and e-mails on the City's SDSShare site.
8. Report Exclusive Community Liaison activities at all progress meetings scheduled by the Resident Engineer.
9. Attendance at pre-construction, community and stakeholders meetings.

7-16.7.1 Exclusive Community Liaison Work Plan. The Work plan for the Exclusive Community Liaison shall address the items of Work specified in these specifications. Present your Exclusive Community Liaison and submit your exclusive community outreach plan (in writing) as **specified in the Special Provisions** within 15 days of the Award of the Contract.

7-16.8 Payment. The Payment for the community outreach and public notices is included in the various Bid items. The payment for exclusive community liaison is in the bid item for "Exclusive Community Liaison Services" when provided as a separate Bid item." If no Bid item has been provided the payment is included in the various Bid items.

7-20 ELECTRONIC COMMUNICATION. ADD the following:

Virtual Project Manager will be used on this contract.

SECTION 8 - FACILITIES FOR AGENCY PERSONNEL

8-2 FIELD OFFICE FACILITIES. To the City Supplement, DELETE in its entirety.

SECTION 9 - MEASUREMENT AND PAYMENT

9-3.2.5 Withholding of Payment. To the City Supplement, item i), DELETE in its entirety and SUBSTITUTE with the following:

- i) Your failure to comply with 7-2.3, “PAYROLL RECORDS” and 2-16, “CONTRACTOR REGISTRATION AND ELECTRONIC REPORTING SYSTEM.”

ADD:

9-3.7 Compensation Adjustments for Price Index Fluctuations. This Contract is not subject to the provisions of The WHITEBOOK for Compensation Adjustments for Price Index Fluctuations for the paving asphalt.

SECTION 203 – BITUMINOUS MATERIALS

203-15 RUBBER POLYMER MODIFIED SLURRY (RPMS). To the City Supplement, CORRECT section numbering as follows:

OLD SECTION NUMBER	TITLE	NEW SECTION NUMBER
203-15	RUBBER POLYMER MODIFIED SLURRY (RPMS)	203-16
203-15.1	General	203-16.1
203-15.2	Materials	203-16.2
203-15.3	Composition and Grading	203-16.3
203-15.4	Mix Design	203-16.4

ADD the following:

RPMS shall be used on this contract.

SECTION 207 – PIPE

207-27 FUSIBLE NON-PRESSURE POLYVINYLCHLORIDE PIPE. DELETE in its entirety.

SECTION 209 – STREET LIGHTING AND TRAFFIC SIGNAL MATERIALS

209-6.4 Induction Cobra Head Luminaire. To the City Supplement, CORRECT certain section numbering as follows:

OLD SECTION NUMBER	TITLE	NEW SECTION NUMBER
209-6.4.7	Luminaire Identification	209-6.4.8
209-6.4.8	Photometric Documentation	209-6.4.9
209-6.4.9	Quality Assurance	209-6.4.10

SECTION 212 - LANDSCAPE AND IRRIGATION MATERIALS

212-3.2.2.3 Trench Marker Tape. To the City Supplement, DELETE in its entirety and SUBSTITUTE with the following:

- a) Trench marker tape shall be 6” wide and consist of a minimum 5.0 mil, five-ply 100% virgin polyethylene which is acid, alkaline and corrosion resistant. Elongation properties and tensile strength of not less than 7,800 psi shall be in accordance with ASTM D882-80A. The trench marker tape for water lines shall have a minimum 20 gauge solid aluminum foil core, adhered to a 2.55 mil polyethylene backing.
- b) Tape color and legend shall be placed beneath the top protective layer subject to the following:
 1. Blue with “Caution Potable Water Line Buried Below” for Water mainlines and over pipe sleeves.
 2. Purple with “Caution Recycled/Reclaimed Water Line Buried Below” for recycled water irrigation mainlines.
 3. Red with “Caution Electric Line Buried Below” for electrical lines servicing the irrigation system, including, but not limited to, 110/220v power to irrigation controllers and pumps, communication cables and irrigation direct burial control wires to remote control valves.
 4. Green with “Caution Sewer Line Buried Below” for Sewer mainlines and over pipe sleeves.

SECTION 300 – EARTHWORK

300-1.4 Payment. To the City Supplement, paragraph (2), DELETE in its entirety and SUBSTITUTE with the following:

2. Payment for existing pavement removal and disposal of up to 12” thick, within the excavation e.g., trench limits, shall be included in the Bid item for installation of the mains or the Work item that requires pavement removal.

SECTION 302 – ROADWAY SURFACING

302-3 PREPARATORY REPAIR WORK. To the City Supplement, DELETE in its entirety and SUBSTITUTE with the following:

302-3 PREPARATORY REPAIR WORK.

1. Prior to roadway resurfacing or the application of slurry, the Contractor shall complete all necessary preparation and repair work to the road segment e.g., tree trimming, weed spray, weed abatement, crack sealing, asphalt repair, hump removal, miscellaneous asphalt patching, removal of raised pavement markers, removal of pavement markings, etc. and as specified in the Special Provisions.
2. Preparatory work shall include, but not be limited to, tree trimming, weed spray, weed abatement, crack sealing, asphalt repair i.e., mill and pave, hump removal, miscellaneous asphalt patching, removal of raised pavement markers, removal of pavement markings, etc.
3. The Contractor shall repair areas of distressed asphalt concrete pavement by milling or removing damaged areas of pavement to a minimum depth of 2” for Residential streets, and a minimum depth of 3” for all others to expose firm and unyielding pavement. The Contractor shall prepare subgrade as needed and install a minimum of 2” for residential streets, and a minimum of 3” for all others, of compacted asphalt concrete pavement over compacted native material as directed by the Engineer.
4. If, in order to achieve the minimum specified depth, the base material is exposed, the material shall be compacted to 95% relative compaction to a depth 10” below the finished grade (dig out). Compaction tests shall be made to ensure compliance with the specifications. The Engineer will determine when and where the test will occur. The City will pay for the soils testing required by the Engineer, which meets the required compaction. The Contractor shall reimburse the City for the cost of retesting failing compaction tests. If additional base material is required, the Contractor shall use Class 2 Aggregate Base in accordance with 200-2.2, “Crushed Aggregate Base.”
5. Recycled base material shall conform to Crushed Miscellaneous Base Material in accordance with 200-2.4, “Crushed Miscellaneous Aggregate Base.”
6. Prior to replacing asphalt, the area shall be cleaned by removing all loose and damaged material, moisture, dirt, and other foreign matter and shall be tack coated in accordance with 302-5.4 “Tack Coat.”
7. The Contractor shall install new asphalt within the repair area or for patches in accordance with 302-5, “ASPHALT CONCRETE PAVEMENT.” Asphalt concrete shall be C2-PG 64-10 in compliance with 400-4, “ASPHALT CONCRETE.”
8. No preparatory asphalt work shall be done when the atmospheric temperature is below 50 °F or during unsuitable weather.

9. Following the asphalt placement, the Contractor shall roll the entire area of new asphalt in both directions at least twice. The finished patch shall be level and smooth in compliance with 302-5.6.2 “Density and Smoothness.” After placement and compaction of the asphalt patch, the Contractor shall seal all finished edges with a 4” wide continuous band of SS-1H.
10. The minimum dimension for each individual repair shall be 4’ x 4’ and shall be subject to the following conditions:
 - a) If the base material is exposed to achieve the required minimum removal thickness, the base material shall be prepared conforming to 301-1, “SUBGRADE PREPARATION.”
 - b) When additional base material is required, then the contractor shall use Class 2 Aggregate Base in accordance with 200-2.2, “Crushed Aggregate Base.” Recycled base material shall conform to Crushed Miscellaneous Base Material in accordance with 200-2.4, “Crushed Miscellaneous Base.”
 - c) The Contractor may use grinding as a method for removal of deteriorated pavement when the areas indicated for removal are large enough (a minimum of the machine drum width) and when approved by the Engineer.
 - d) For both scheduled and unscheduled base repairs, failed areas may be removed by milling or by excavation provided that the edges are cut cleanly with a saw. The areas shall be cleaned and tack coated in accordance with 302-5.4, “Tack Coat” before replacing the asphalt. The areas for scheduled repairs have been marked on the street.

302-3.1 Asphalt Patching.

1. Asphalt patching shall consist of patching potholes, gutter-line erosion, and other low spots in the pavement that are deeper than ½” per 302-5.6.2, “Density and Smoothness.” These areas are generally smaller and more isolated than those areas in need of mill and pave.
2. The areas requiring patching have been identified in the Contract Documents, marked on the streets, or as directed by the Engineer. The Contractor shall identify any new areas that may require patching prior to slurry work to ensure the smoothness and quality of the finished product.
3. The Contractor shall identify and repair any areas that may require patching, prior to the placement of slurry seal for smooth finished product.
4. Asphalt overlay shall not be applied over deteriorated pavement. Preparatory asphalt work shall be completed and approved by the Engineer before proceeding with asphalt overlay.
5. The Contractor shall remove distressed asphalt pavement either by saw cutting or milling, to expose firm and unyielding pavement; prepare subgrade (as needed); and install compacted asphalt concrete pavement over compacted native material as directed by the Engineer.

6. Prior to replacing asphalt, the area shall be cleaned and tack coated per 302-5.4, "Tack Coat".
7. Following the asphalt placement, the Contractor shall roll the entire patch in both directions covering the patch at least twice.
8. After placement and compaction of the asphalt patch, the Contractor shall seal all finished edges with a 4" wide continuous band of SS-1H.
9. Base repairs shall not exceed 20% RAP in content.

302-3.2 Payment.

1. Payment for replacement of existing pavement when required shall be included in the unit bid price for Asphalt Pavement repair for the total area replaced and no additional payment shall be made regardless of the number of replacements completed. No payment shall be made for areas of over excavation or outside trench areas in utility works unless previously approved by the Engineer. No payment for pavement replacement will be made when the damage is due to the Contractor's failure to protect existing improvements. The Contractor shall reimburse the City for the cost of retesting all failing compaction tests.
2. The areas and quantities shown on the road segments and in appendices are given only for the Contractor's aid in planning the Work and preparing Bids. The Engineer will designate the limits to be removed and these designated areas shall be considered to take precedent over the area shown in an Appendix to the Contract Documents. The quantities shown in the appendices are based on a street assessment survey and may vary.
3. At the end of each day, the Contractor shall submit to the Engineer an itemized list of the asphalt pavement repair work completed. The list shall include the location of the work and the exact square footage of the repair.
4. Preparatory repair work and tack coating will be paid at the Contract unit price per ton for Asphalt Pavement Repair. No payment shall be made for areas of over excavation unless previously approved by the Engineer.
5. Milling shall be included in the Bid item for Asphalt Pavement Repair unless separate Bid item has been provided.
6. Payment for miscellaneous asphalt patching shall be included in the Contract unit price for slurry and no additional payment shall be made therefore.

302-5.1.1 Damaged AC Pavement Replacement. To the City Supplement, DELETE in its entirety.

302-5.1.2 Measurement and Payment. To the City Supplement, DELETE in its entirety.

302-5.2.1 Measurement and Payment. To the City Supplement, item c), ADD the following:
Imported Subgrade material shall be paid per bid item "Imported Backfill".

SECTION 306 – UNDERGROUND CONDUIT CONSTRUCTION

306-1 OPEN TRENCH OPERATIONS. To the City Supplement, CORRECT certain section numbering as follows:

OLD SECTION NUMBER	TITLE	NEW SECTION NUMBER
306-1.8	House Connection Sewer (Laterals) and Cleanouts	306-1.9
306-1.7.1	Payment	306-1.9.1
306-1.7.2	Sewer Lateral with Private Replumbing	306-1.9.2
306-1.7.2.1	Location	306-1.9.2.1
306-1.7.2.2	Permits	306-1.9.2.2
306-1.7.2.3	Submittals	306-1.9.2.3
306-1.7.2.4	Trenchless Construction	306-1.9.2.4
306-1.7.2.5	Payment	306-1.9.2.5
306-1.7.3.6	Private Pump Installation	306-1.9.2.6
306-1.7.3.7	Payment	306-1.9.2.7

306-1.6 Basis of Payment for Open Trench Installations. ADD the following:

Payment for imported backfill when the Contractor elects to import material from a source outside the project limits and when authorized by the Engineer shall be included in the Bid unit price for Imported Backfill. The price shall include the removal and disposal of unsuitable materials.

306-22 PIPE FUSION. DELETE in its entirety.

SECTION 500 – PIPELINE

500-1.1.1 General. To the City Supplement, (1) (a), ADD the following:

The felt and resin system shall be selected from those listed in the City’s approved material list.

500-1.1.5 Video Inspection. To the City Supplement, after the last paragraph, ADD the following:

During the pre-installation video the contractor must identify all existing protruding laterals with the existing main and trim them flush to the main prior to rehabilitation. The cost of trimming the existing laterals will be included in the pipe rehabilitation bid item.

500-1.1.9 Measurement and Payment. Third Paragraph, DELETE in its entirety.

500-1.2.4 Sewer Bypassing and Dewatering. DELETE in its entirety and SUBSTITUTE with the following:

When required by the Contract Documents or the process, the Contractor shall bypass the sewer flow around the Work and dewater the Site in conformance with 704, "SEWAGE SPILL PREVENTION" and 705-2.1, "General"

500-1.2.7 Payment. To the City Supplement, ADD the following:

3. The sewer lateral repair work will be measured and paid for at the unit price bid per each sewer lateral point repair. Measurement will be made at the pipe and will be based on the length of lateral repaired. The Contractor will be paid for 1 sewer lateral repair for each repair 6' or less in length.
4. The payment for Additional sewer lateral Point Repair shall cover sewer lateral point repairs continuous with and in addition to the basic 6' repair, Measurement and Payment will be made at the sewer lateral and will be based on the length of the lateral repaired less the basic 6' paid under sewer lateral Point Repair.

500-1.4.1 General. To the City Supplemental, ADD the following:

Second sentence, DELETE in its entirety and SUBSTITUTE with the following:

1. CIPP liner for the rehabilitation of pipelines shall be either the Type A - inversion process to compliance with ASTM F1216 or the Type B - pull-in place process in compliance with ASTM F1743 for installation using heated water cure. CIPP Liner for rehabilitation of pipelines shall use approved polyester, epoxy, or epoxy-vinyl ester-resin-impregnated flexible fabric tube.
2. The CIPP liner shall extend the full length of the pipe reach to be rehabilitated and shall provide a structurally sound, impermeable, seamless, joint-less close-fitting pipe, that when cured, is bonded to the host pipe.

500-1.6 Service Laterals. To the City Supplement, DELETE in its Entirety and SUBSTITUTE with the following:

ADD:

500-1.6 Service Lateral Rehabilitation.

500-1.6.1 General.

1. The rehabilitation shall be accomplished using a fabric or fiberglass tube of particular length and a thermoset resin with physical and chemical properties appropriate for the application. The tube is vacuum impregnated with the resin. Access to an upstream end of the service lateral is made by excavation in the public right of way. Installation of the resin-impregnated tube into the service lateral may be performed either by Type A inversion in accordance with ASTM F1216 or by Type B pull-in in accordance with ASTM F 1743, and may be performed from either the mainline or the excavated end of the lateral.

2. The cured-in-place liner shall extend the entire length of the lateral from the access point to the mainline. The liner shall be extended sufficiently to create a water tight seal at the main and the liner interface. Once the tube or resin composite is cured, the installation equipment shall be removed and the protruding end in the collector shall be cut using a robotic cutting device. A sewer cleanout in accordance with the Standard Drawing SDS-102 “Sewer Lateral Cleanout (In Driveway, Paved Alley, Sidewalk, or Other Area Subject to Traffic)” or SDS-103 “Sewer Lateral Cleanout Outside Traveled Way” shall be installed at the access point and properly backfilled.
3. The liner shall be extended sufficiently to create a water tight seal at the main and the liner interface.
4. If there is a SLC in place, then the cured-in-place lateral liner shall have a minimum overlap of 2” over the previously installed SLC sewer main lateral connection.

500-1.6.2 Material.

- a) The tube shall consist of one or more layers of flexible needled felt, or an equivalent material. Where the tube is fabricated from non woven felt, the longitudinal and circumferential joints are made up by seal bonding. The tube shall be capable of conforming to bends, off-set joints, bells, and disfigured pipe sections. The resin and catalyst system as designed for the specific application shall meet the chemical resistance requirements of 210-2.3.3, “Chemical Resistance Test (Pickle Jar Test).”
- b) The composite of the materials above shall, upon installation inside the host pipe, shall exceed the minimum test standards specified in Table 500-1.4.2 (A).

500-1.6.3 Installation Procedures (ASTM F1216-98 and ASTM F1743).

- a) The Property Owner of the lateral being reconstructed shall be informed, and the flow stopped, for the period of reconstruction work. Bypass
- b) The Contractor shall excavate an access pit at the appropriate upstream point on the service lateral in accordance with the reconstruction length determined by the Engineer.
- c) The Contractor shall always clean and color video the lateral line immediately prior to reconstruction and determine the structural condition of the pipeline. Roots, debris, and protruding service connections shall be removed prior to reconstruction.
- d) The tube shall be inspected for torn or frayed sections. The tube in good condition shall then be vacuum impregnated with the thermoset resin.
- e) No open pans or uncontrolled open-air pouring of resin shall be allowed during tube saturation. Resin shall be contained within the inflation bladder during vacuum impregnation and insertion. The Contractor shall ensure that no public property is exposed to contamination by liquid resin compounds or components.

- f) The saturated tube along with the inflation bladder shall be inserted into the installation equipment and the end closed. The entire installation equipment shall be placed in the pipe access pit and aligned with the exposed end of the pipe.
- g) The resin and tube shall be completely protected during the placement. The resin shall not be contaminated or diluted by exposure to dirt, debris, or water during the placement.
- h) The tube shall be installed from the installation equipment by controlled air, water or steam pressure as in accordance with manufacturer instructions. The installation shall be stopped when the tube extends the entire length of the lateral section to be lined. The tube is held tightly in place against the wall of the host pipe by the pressure until the cure is complete.
- i) When the curing process is complete, the pressure is released and the inflation bladder reverted back into the installation equipment and removed from the pit.
- j) No barriers, coatings, or any material other than the cured tube or resin composite specifically designed for desirable physical and chemical resistance properties shall be left in the host pipe. Any materials used in the installation other than the cured tube or resin composite shall be removed.
- k) Any cured tube or resin composite pipe left protruding from the service connection shall be trimmed back using a hydraulic-powered robotic cutting device specifically designed for cutting cured-in-place pipe made from these materials.
- l) A second color video inspection shall be performed to verify the proper cure of the material, the proper trim of service connection, and the integrity of the seamless pipe.
- m) The bypass pumping system shall be removed and the sewer flows restored to normal flow conditions. The service lateral pipes shall be coupled together. The excavation shall be properly backfilled. The property owner of the service connection shall be informed when the Work is complete.

500-1.6.4 **Deviations.** If pre-installation inspection reveals conditions in the service lateral to be substantially different than those used in the design of wall thickness, tube construction, tube length, or resin system; then the Contractor shall correct the situation as approved by the Engineer.

500-1.6.5 **Acceptance.** Upon completion, the Contractor shall deliver the video records and written reports to the Engineer. The Engineer shall review the documentation and the Site to determine if the Work is complete and the work may be accepted.

500-1.6.6 **Payment.**

- a) Payment for the Work covered under 500-1.6, “Service Laterals Rehabilitation” shall be made per each lateral.

- b) The payment for the installation of a sewer cleanout at the access point and televising of the service laterals shall be included in the payment for lateral rehabilitation.
- c) Payment for in-situ point repairs shall be included in the bid price for in-situ point repairs and paid for in accordance with 500-1.1.9, “Measurement and Payment” and 500-1.2.7, “Payment.”

500-1.7.10 Payment. To the City Supplement, DELETE in its entirety.

500-1.10.7 Payment. To the City Supplement, DELETE in its entirety.

500-1.13.10 Payment. To the City Supplement, DELETE in its entirety.

500-4 SERVICE LATERAL CONNECTION SEALING. DELETE in its entirety and SUBSTITUTE with the following:

500-4 SERVICE LATERAL CONNECTION (SLC) SEALING.

500-4.1 General.

1. SLC is the interface of the house sewer lateral with the main sewer. SLC to rehabilitated sanitary sewer lines shall be sealed, normally without excavation, by the installation of a resin-impregnated, flexible, felt tube or fiberglass tube installed into the existing service lateral. The tube shall form a “tee” section with a full lap inside the main pipe and shall extend continuously from the sewer main into the lateral for a minimum of 4”. SLC may be a combination of “tees” or “wyes” of varying angle. The resin shall be cured to form the tube into a hard impermeable pipe-within-a-pipe. When cured, the SLC shall seal the connection of the lateral to the mainline in a continuous tight-fitting, watertight pipe-within-a-pipe to eliminate any visible leakage between the lateral and mainline and shall provide a leak-proof seal designed for a minimum 50-year life to prevent root intrusion, infiltration, and exfiltration between a liner and a host pipe.
2. Prior to cleaning and pre-rehab video inspection, the Contractor shall submit a detailed operational plan for the proposed cleaning of all roots inside the pipe and around the service connection for the Engineer’s approval. After cleaning, the Contractor shall proceed with lining of the pipe and reinstating all live service connections. The service connection openings shall conform to the shape and the size of the inside diameter of the existing service connection. Contractor shall use a wire brush or other methods and equipment as recommended by other lining system providers, or other approved means and methods to provide a smooth opening for connecting the lateral to the newly lined pipeline.
3. The Contractor shall trim all protruding laterals which interfere with the lining installation, as flush with the pipe interior as practicable.

500-4.2 Reference Specification. This specification references ASTM test methods which are made a part hereof by such reference and shall be the latest edition and revision thereof and shall meet the chemical resistance requirements of section 210-2.3.3, “Chemical Resistance Test (Pickle Jar Test).”

500-4.3 General Corrosion Requirements.

- a) The finished SLC product shall be fabricated from materials which when cured shall be chemically resistant to withstand internal exposure to domestic sewage and shall meet the chemical resistance requirements of 210-2.3.3, “Chemical Resistance Test (Pickle Jar Test)” and Table 210-2.4.1 (A).
- b) The SLC product shall be compatible with the lining system materials utilized in the main sewer line.

500-4.4 SLC Materials.

- a) A flexible, felt tube shall be fabricated to neatly fit the internal circumference of the conduit specified by the City. Allowance shall be made for circumferential stretching during insertion.
- b) The SLC connection shall extend minimum 4” from the mainline into the lateral.
- c) The Contractor shall furnish a specially designed, unsaturated polyester or vinyl ester resin, and catalyst system compatible with the SLC process that provides cured physical strengths specified herein.

500-4.5 Physical Properties.

- a) The cured SLC shall conform to the minimum structural standards as listed in Table 500-1.4.2 (A).
- b) No cured-in-place pipe rehabilitation technology shall be allowed that requires bonding to the existing pipe for any part of its structural strength.
- c) Design methods are to be derived for various loading parameters and modes of failure. Equations shall be modified to include deformation in the shape of an oval as a design parameter. The design method shall be submitted to the Engineer for approval prior to the Pre-construction Meeting.

500-4.6 Installation Preparation.

- a) The Contractor shall remove internal debris out of the sewer line.
- b) Inspection of pipelines shall be performed by experienced personnel trained in locating breaks and obstacles by closed circuit television. The interior of the pipeline shall be carefully inspected to determine the location of any conditions which may prevent proper installation of the SLC into the pipelines, and it shall be noted so that these conditions can be corrected. A color video and suitable log shall be kept for later reference by the City.
- c) The Contractor, when required, shall provide for the flow of sewage around the section or sections of mainline pipe where the service lateral designated for SLC is located. The bypass shall be made by plugging the line at an existing upstream manhole and pumping the flow into a downstream manhole or adjacent system. The pump and bypass lines shall be of adequate capacity and size to handle the flow without service interruption. The bypass systems shall be approved in advance by the City.

- d) The service lateral shall be inactive during the time of installation.
- e) The Contractor shall clear the line of obstructions that prevent the insertion of the SLC material. If inspection reveals an obstruction that cannot be removed by conventional sewer cleaning equipment, the Contractor shall make an external point repair excavation to uncover and remove the obstruction. The Contractor shall inform the Engineer prior to the commencement of the Work.
- f) The mainline pipe opening shall be prepared to accept the SLC and the mainline rehabilitated pipe shall be maximized to obtain the best possible connection.
- g) The transition from the mainline pipe to the service lateral shall be smooth and continuous to provide adequate support for the SLC during installation and cure.

500-4.7 SLC Installation.

- a) The resin impregnated tube shall be loaded inside a pressure apparatus. The pressure apparatus, attached to a robotic device, shall be positioned in the mainline pipe at the service connection. The robotic device, together with a television camera, shall be used to align the SLC repair with the service connection opening. Air pressure, supplied to the pressure apparatus through an air hose, shall be used to invert the resin impregnated SLC into the lateral pipe. The inversion pressure shall be adjusted to fully invert the SLC into the lateral pipe and hold the tube tight to the pipe wall. Care shall be taken during the curing process not to over-stress the tube.
- b) The pressure apparatus shall include a bladder which shall inflate in the mainline pipe, effectively seating the SLC repair against the service connection.
- c) After inversion or pull in is completed, recommended pressure is maintained on the impregnated tube for the duration of the curing process. Curing method shall be compatible with the resin selected. An ultraviolet (UV) light cured, heat cured or ambient cured resin system is typically used.
- d) The initial cure shall be deemed to be completed when the SLC has been exposed to the UV light, heat source or held in place for the time period specified by the manufacturer.
- e) The Contractor shall cool the hardened SLC before relieving the pressure in the pressure apparatus. Cool-down may be accomplished by the introduction of cool air into the pressure apparatus. Care shall be taken to maintain proper pressure throughout the cure and cool-down period.
- f) The finished SLC shall be free of dry spots, lifts and delamination. The lateral SLC shall not inhibit the closed circuit television post video inspection of the mainline or service lateral pipes. Frayed ends of the SLC repair shall be removed prior to acceptance.
- g) During the warranty period, any defects which shall affect the integrity of strength of the SLC shall be repaired at the Contractor's expense in a manner mutually agreed upon by the manufacturer, City, and the Contractor.

h) After the Work is completed, the Contractor shall provide the City with a video disc showing the completed work including the restored conditions.

500-4.8 Clean-Up. Upon acceptance of the installation work, the Contractor shall reinstate the Site affected by its operations.

500-4.9 Payment. Payment for SLC sealing systems shall be made at the Contract Unit Price or lump sum price in the Bid for each SLC. The Contract Unit Price or lump sum price in the Bid shall include the installation of the SLC sealing system, surface preparation and repairs, preparation and tape submittal of all pre- and post-construction CCTV inspection, bypassing if required, and testing, unless otherwise specified in the Special Provisions.

SECTION 700 – EXTENDED REVEGETATION, MAINTENANCE, AND MONITORING

700-1.7.2 Project Biologist. To the City Supplement, ADD the following:

The City will retain a qualified Project Biologist to perform biological monitoring work for this contract. You must coordinate your activities and Schedule with the activities and schedules of the Biologist Monitor.

SECTION 705 – WATER DISCHARGES

705-2.6.1 General. Paragraph (3), CORRECT reference to Section 803 to read “Section 703.”

705-2.6.3 Community Health and Safety Plan. To the City Supplement, DELETE in its entirety and SUBSTITUTE with the following:

See 703-2, “Community Health and Safety Plan.”

SECTION 707 – RESOURCE DISCOVERIES

ADD:

707-1.1 Environmental Document. The City of San Diego Environmental Analysis Section (EAS) of the Development Services Department has prepared a **Mitigated Negative Declaration** for **Sewer Group 691**, as referenced in the Contract Appendix. You must comply with all requirements of the **Mitigated Negative Declaration** as set forth in the Contract Appendix.

END OF SUPPLEMENTARY SPECIAL PROVISIONS (SSP)

SUPPLEMENTARY SPECIAL PROVISIONS

APPENDICES

APPENDIX A

SITE DEVELOPMENT PERMIT AND MITIGATED NEGATIVE DECLARATION

RECORDING REQUESTED BY
CITY OF SAN DIEGO
DEVELOPMENT SERVICES
PERMIT INTAKE, MAIL STATION 501

WHEN RECORDED MAIL TO
PROJECT MANAGEMENT
PERMIT CLERK
MAIL STATION 501

THE ORIGINAL OF THIS DOCUMENT
WAS RECORDED ON MAY 07, 2014
DOCUMENT NUMBER 2014-0185538
Ernest J. Dronenburg, Jr., COUNTY RECORDER
SAN DIEGO COUNTY RECORDER'S OFFICE
TIME: 10:04 AM

SPACE ABOVE THIS LINE FOR RECORDER'S USE

WBS NUMBER: B-00446.02.01.03

SITE DEVELOPMENT PERMIT NO. 1013063
SEWER GROUP 691 PROJECT NO. 284769 (MMRP)
DEVELOPMENT SERVICES DEPARTMENT, PROCESS CIP-2

This Site Development Permit No. 1013063 is granted by the Development Services Department of the City of San Diego to the City of San Diego, Engineering and Capital Projects, Owner, and Permittee, pursuant to San Diego Municipal Code [SDMC] section 126.0504. The Sewer Group 691 project is primarily located in the public right-of-way on the eastside of Balboa Park Municipal Golf Course and Switzer Canyon west of 32nd Street between Nutmeg and Grape Street and in the following Zones: RS-1-1, RS-1-7, GH-CC, and GH-3000.

Subject to the terms and conditions set forth in this Permit, permission is granted to City of San Diego, Engineering and Capital Projects, Owner, and Permittee to replacement and/or abandon approximately 4,388 linear feet (LF) of sewer main, realign approximately 3,945 LF of an 8-inch sewer pipe, rehabilitate 381 LF of 10-inch sewer main, and abandon 2,403 LF of sewer pipe described and identified by size, dimension, quantity, type, and location on the approved exhibits [Exhibit "A"] dated April 30, 2014, on file in the Development Services Department.

The project shall include:

- a. Realign 3,945 Linear Feet (LF) of an 8-inch sewer pipe;
- b. Rehabilitate 381 LF of a 10-inch sewer pipe;
- c. Abandon 2,403 LF of sewer pipe;



STANDARD REQUIREMENTS:

1. This permit must be utilized within thirty-six (36) months after the date on which all rights of appeal have expired. If this permit is not utilized in accordance with Chapter 12, Article 6, Division 1 of the SDMC within the 36 month period, this permit shall be void unless an Extension of Time has been granted. Any such Extension of Time must meet all SDMC requirements and applicable guidelines in effect at the time the extension is considered by the appropriate decision maker.
2. No permit for the construction, occupancy, or operation of any facility or improvement described herein shall be granted, nor shall any activity authorized by this Permit be conducted on the premises until:
 - a. The Owner/Permittee signs and returns the Permit to the Development Services Department; and
 - b. The Permit is recorded in the Office of the San Diego County Recorder.
3. While this Permit is in effect, the subject property shall be used only for the purposes and under the terms and conditions set forth in this Permit unless otherwise authorized by the appropriate City decision maker.
4. The continued use of this Permit shall be subject to the regulations of this and any other applicable governmental agency.
5. Issuance of this Permit by the City of San Diego does not authorize the Owner/Permittee for this Permit to violate any Federal, State or City laws, ordinances, regulations or policies including, but not limited to, the Endangered Species Act of 1973 [ESA] and any amendments thereto (16 U.S.C. § 1531 et seq.).
6. The Owner/Permittee shall secure all necessary building permits. The Owner/Permittee is informed that to secure these permits, substantial building modifications and site improvements may be required to comply with applicable building, fire, mechanical, and plumbing codes, and State and Federal disability access laws.
7. Construction plans shall be in substantial conformity to Exhibit "A." Changes, modifications, or alterations to the construction plans are prohibited unless appropriate application(s) or amendment(s) to this Permit have been granted.
8. All of the conditions contained in this Permit have been considered and were determined-necessary to make the findings required for approval of this Permit. The Permit holder is required to comply with each and every condition in order to maintain the entitlements that are granted by this Permit.

If any condition of this Permit, on a legal challenge by the Owner/Permittee of this Permit, is found or held by a court of competent jurisdiction to be invalid, unenforceable, or unreasonable,

this Permit shall be void. However, in such an event, the Owner/Permittee shall have the right, by paying applicable processing fees, to bring a request for a new permit without the "invalid" condition(s) back to the discretionary body which approved the Permit for a determination by that body as to whether all of the findings necessary for the issuance of the proposed permit can still be made in the absence of the "invalid" condition(s). Such hearing shall be a hearing de novo, and the discretionary body shall have the absolute right to approve, disapprove, or modify the proposed permit and the condition(s) contained therein.

ENVIRONMENTAL/MITIGATION REQUIREMENTS:

9. Mitigation requirements in the Mitigation, Monitoring, and Reporting Program [MMRP] shall apply to this Permit. These MMRP conditions are hereby incorporated into this Permit by reference.

10. The mitigation measures specified in the MMRP and outlined in **Mitigated Negative Declaration (MND)**, 284769(SCH No. 2013101058), shall be noted on the construction plans and specifications under the heading ENVIRONMENTAL MITIGATION REQUIREMENTS.

11. The Owner/Permittee shall comply with the MMRP as specified in **Mitigated Negative Declaration (MND)**, 284769(SCH No. 2013101058), to the satisfaction of the Development Services Department and the City Engineer. Prior to the issuance of the "Notice to Proceed" with construction, all conditions of the MMRP shall be adhered to, to the satisfaction of the City Engineer. All mitigation measures described in the MMRP shall be implemented for the following issue areas:

Paleontological Resources

Historical Resources (Archaeological)

Land Use – Multi-Habitat Planning Area (MHPA)

INFORMATION ONLY:

- The issuance of this discretionary use permit alone does not allow the immediate commencement or continued operation of the proposed use on site. The operation allowed by this discretionary use permit may only begin or recommence after all conditions listed on this permit are fully completed and all required ministerial permits have been issued and received final inspection.
- Any party on whom fees, dedications, reservations, or other exactions have been imposed as conditions of approval of this Permit, may protest the imposition within ninety days of the approval of this development permit by filing a written protest with the City Clerk pursuant to California Government Code-section 66020.
- This development may be subject to impact fees at the time of construction permit issuance.



APPROVED by the Development Services Department of the City of San Diego on April 30, 2014 and Resolution No. CIP 284769.



AUTHENTICATED BY THE CITY OF SAN DIEGO DEVELOPMENT SERVICES
DEPARTMENT

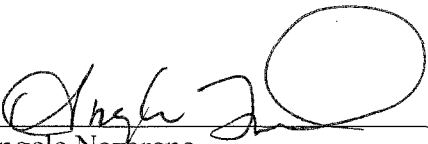

Angela Nazareno
Development Project Manager

**NOTE: Notary acknowledgment
must be attached per Civil Code
section 1189 et seq.**

**The undersigned Owner/Permittee, by execution hereof, agrees to each and every condition of
this Permit and promises to perform each and every obligation of Owner/Permittee hereunder.**

City of San Diego, Engineering and Capital Projects
Owner/Permittee

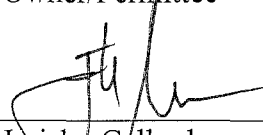
By 

Jericho Gallardo
Project Engineer

**NOTE: Notary acknowledgments
must be attached per Civil Code
section 1189 et seq.**

CALIFORNIA ALL-PURPOSE ACKNOWLEDGMENT
CIVIL CODE § 1189

State of California }
County of San Diego }
On May 6, 2014 before me, Vivian M. Gies, Notary Public
Date Here Insert Name and Title of the Officer
personally appeared Angela Nazareno, Jericho Gallardo
Name(s) of Signer(s)

who proved to me on the basis of satisfactory evidence to be the person(s) whose name(s) ~~is~~ are subscribed to the within instrument and acknowledged to me that ~~he~~~~she~~ they executed the same in ~~his~~~~her~~ their authorized capacity(ies), and that by ~~his~~~~her~~ their signature(s) on the instrument the person(s), or the entity upon behalf of which the person(s) acted, executed the instrument.

I certify under PENALTY OF PERJURY under the laws of the State of California that the foregoing paragraph is true and correct.

WITNESS my hand and official seal.

Signature: Vivian M. Gies
Signature of Notary Public



Place Notary Seal Above

OPTIONAL

Though this section is optional, completing this information can deter alteration of the document or fraudulent reattachment of this form to an unintended document.

Description of Attached Document

Title or Type of Document: PTS 284769/Sewer Group 691 Document Date: _____

Number of Pages: _____ Signer(s) Other Than Named Above: _____

Capacity(ies) Claimed by Signer(s)

Signer's Name: _____	Signer's Name: _____
<input type="checkbox"/> Corporate Officer — Title(s): _____	<input type="checkbox"/> Corporate Officer — Title(s): _____
<input type="checkbox"/> Partner — <input type="checkbox"/> Limited <input type="checkbox"/> General	<input type="checkbox"/> Partner — <input type="checkbox"/> Limited <input type="checkbox"/> General
<input type="checkbox"/> Individual <input type="checkbox"/> Attorney in Fact	<input type="checkbox"/> Individual <input type="checkbox"/> Attorney in Fact
<input type="checkbox"/> Trustee <input type="checkbox"/> Guardian or Conservator	<input type="checkbox"/> Trustee <input type="checkbox"/> Guardian or Conservator
<input type="checkbox"/> Other: _____	<input type="checkbox"/> Other: _____

Signer Is Representing: _____ Signer Is Representing: _____

DEVELOPMENT SERVICES DEPARTMENT RESOLUTION NO. CIP 284769
SITE DEVELOPMENT PERMIT NO. 1013063
SEWER GROUP 691 PROJECT NO. 284769 - MMRP

WHEREAS, CITY OF SAN DIEGO, ENGINEERING AND CAPITAL PROJECTS, Owner/Permittee, filed an application with the City of San Diego for a permit to replacement and/or abandon approximately 4,388 Linear Feet (LF) of sewer main, realign approximately 3,945 LF of an 8-inch sewer pipe, rehabilitate 381 LF of 10-inch sewer main, and abandon 2,403 LF of sewer pipe (as described in and by reference to the approved Exhibits "A" and corresponding conditions of approval for the associated Site Development Permit No. 1013063);

WHEREAS, the project site is located primarily in the public right-of-way on the eastside of Balboa Park Municipal Golf Course and Switzer Canyon west of 32nd Street between Nutmeg and Grape Street in the following Zones: RS-1-1, RS-1-7, GH-CC, and GH-3000 in the Greater North Park and Golden Hill Communities;

WHEREAS, on April 30, 2014, the Development Services Department of the City of San Diego considered SITE DEVELOPMENT PERMIT No. 1013063 pursuant to the Land Development Code of the City of San Diego;

BE IT RESOLVED by the Development Services Department of the City of San Diego as follows:

That the Development Services Department adopts the following written Findings, dated April 30, 2014.

FINDINGS:

Site Development Permit - Section 126.0504

A. Findings for all Site Development Permits.

1. **The proposed development will not adversely affect the applicable land use plan.**
The land use designation of the Greater North Park Community, Greater Golden Hill Community, and Balboa Park Master Plan plans identify the project and surrounding area as residential, both single and multi-family, golf course, as well as park land. Sewer systems are essential public services that are allowed in the land use designations identified in the community plans. Because of the age of some infrastructure in the community sewer maintenance and replacement is occasionally needed. In this case the maintenance would include replacement, rehabilitation, and abandonment. The proposed project would not adversely affect the applicable land use plan.
2. **The proposed development will not be detrimental to the public health, safety, and welfare.** The project will abandon, rehabilitate and replace sewer mains within the City of San Diego's right of way and easements in order to benefit the community. The objective is to replace and upgrade the existing sewer system to allow better flow and decrease the chances of back-ups or breaks. The project also plans to abandon several sewer mains and manholes for better maintenance. The project also includes upgrade existing and installs new curb ramps areas where ramps are not present within the project limits. Following

replacement of the sewer main, the streets will be improved by repairing existing cracks and street surface damages. The overall scope of this project will promote the public health, welfare, and safety.

3. **The proposed development will comply with the applicable regulations of the Land Development Code, including any allowable deviations pursuant to the Land Development Code (LDC).** The project will be realigned mostly within City right of way. It does cross multiple developed and vacant parcels as well, with zoning varying from un-zoned, RM-4-10, RS-1-1, CC-3-5, and RS-1-7. These zones allows for sewer facilities and related ancillary improvements identified for this project. The site is partially located within biologically sensitive areas, and would require construction monitoring. Applicable regulations of the LDC would allow the proposed replacement/realignment of the existing sewer facility and associated improvements. The project as proposed complies with the City Green Book, Landscape Manual, Historical Resources Guidelines, the California Environmental Quality Act Guidelines, and all other applicable regulations of the LDC regarding an existing sewer facility proposed for maintenance. The proposed development would proceed in accordance with all applicable regulations as conditioned within Site Development Permit No. 1013063.

B. Supplemental Findings--Environmentally Sensitive Lands

1. **The site is physically suitable for the design and siting of the proposed development and the development will result in minimum disturbance to environmentally sensitive lands.** Improvements for the sewer pipeline will remain underground and some difficult to access areas will be re-aligned to City right-of-way, where it will be more accessible for future repair, maintenance, and improvement activity. The current design meets the sewer system conveyance requirements, while proposing the least impacts to environmentally sensitive lands (ESL). ESL that occurs in this area includes those that are in or near jurisdictional non-wetland waters, coastal sage scrub, chaparral, oak woodland, and the MHPA. The least impactful methods are proposed: trenching in the right of way and limited ESL areas, rehabilitating manholes and creating subsurface structures for sewer flow, maintenance and access, as well as and tunneling work with associated pits to lessen overall impacts. As such, the overall design considers the balance between the limited impacts to the environment, while at the same time provides the necessary improvements for essential public infrastructure for this area.
2. **The proposed development will minimize the alteration of natural land forms and will not result in undue risk from geologic and erosional forces, flood hazards, or fire hazards.** The project is located in Geologic Hazard Zone 53 as shown on the City's Seismic Safety maps. This zone is characterized by gently sloping to steep terrain, favorable geologic structure low risk. Sensitive construction techniques will include trenching, rehabilitation, and abandonment to ensure minimal alteration to landform. Where paving exists or removed, these areas would be re-paved. Some of the project is located within an unnamed stream. Minor work would be done in the creek in order to connect manholes. Erosion control measures for construction BMPs as well as post construction revegetation would protect for erosional forces. In addition, the system would be designed to meet the necessary seismic requirements for underground sewer pipelines to limit geologic risk along the entire

alignment. Because of the underground nature of the project, no effects would occur in this category, or from fire hazard.

3. **The proposed development will be sited and designed to prevent adverse impacts on any adjacent environmentally sensitive lands (ESL).** The project is an underground project that minimizes all impacts to ESL in order to provide adequate public sewer service to the area. The potential of future spills and maintenance access would be reduced into the sensitive areas because of the re-habilitation and replacement. There would be less maintenance access needs within the sensitive areas. The proposal has incorporated the least impactful sewer alignments and access. As a result, this project lessens all impacts to ESL overall.
4. **The proposed development will be consistent with the City of San Diego's Multiple Species Conservation Program (MSCP) Subarea Plan.** Portions of the proposed project are within and adjacent to the Multi-Habitat Planning Area (MHPA) of the City of San Diego Multiple Species Conservation Program (MSCP) Subarea. The Subarea Plan states that temporary access paths must not disturb existing habitat if possible, and that utility lines should be designed to avoid or minimize intrusion into the MHPA unless otherwise not feasible, and then to the least sensitive areas only and with appropriate mitigation. The project's design includes biological monitoring, avoids sensitive areas to the maximum extent possible, and includes revegetation and mitigation to adequately meet the requirements of the MSCP Subarea Plan. Therefore the project is consistent with the City of San Diego's MSCP Subarea Plan.
5. **The proposed development will not contribute to the erosion of public beaches or adversely impact local shoreline sand supply.** The proposed project is not located in close proximity to the beach or shoreline and will not adversely impact local shoreline sand supply. Improvements are minimal and the land would be returned back to its pre-construction stage. Erosion control shall be implemented in order to prevent inappropriate runoff, and the project will have no adverse impacts to such resources.
6. **The nature and extent of mitigation required as a condition of the permit is reasonably related to, and calculated to alleviate, negative impacts created by the proposed development.** The mitigation developed for this project is for biological, archaeological, and paleontological resources, and the extent of such mitigation is typical for a project of this nature. As a result, the mitigation is directly related to the project, its requirements, the need to construct the project, while at the same time alleviating any negative impacts that may occur as a result of this project because the appropriately developed mitigation will satisfy all such requirements.

BE IT FURTHER RESOLVED that, based on the findings hereinbefore adopted by the Development Services Department, Site Development Permit NO. 1013063 is hereby GRANTED by the Development Services Department of the City of San Diego to the referenced Owner/Permittee, in the form, exhibits, terms and conditions as set forth in Permit No. 1013063 a copy of which is attached hereto and made a part hereof.

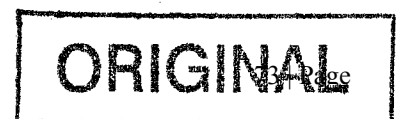

Angela Nazareno

Angela Nazareno
Development Project Manager
Development Services

Adopted on: April 30, 2014

WBS No. B-00446.02.01.03

ORIGINAL Page

RESOLUTION NUMBER CIP 284769
MITIGATED NEGATIVE DECLARATION NO. 284769
SEWER GROUP 691
ADOPTED ON April 25, 2014

WHEREAS, on June 13, 2012, City of San Diego, Engineering and Capital Projects submitted an application to Development Services Department for a Site Development Permit for the Sewer Group 691 (Project); and

WHEREAS, the matter was considered without a public hearing by Development Services Department Staff designated by the City Manager or designee of the City of San Diego; and

WHEREAS, the issue was heard by the Development Services Department Staff designated by the City Manager on April 28, 2014; and

WHEREAS, the Development Services Department Staff considered the issues discussed in Mitigation Negative Declaration No. 284769 (Declaration) prepared for this Project; NOW THEREFORE,

BE IT RESOLVED, by the Development Services Department Staff that it is certified that the Declaration has been completed in compliance with the California Environmental Quality Act of 1970 (CEQA) (Public Resources Code Section 21000 et seq.), as amended, and the State CEQA Guidelines thereto (California Code of Regulations, Title 14, Chapter 3, Section 15000 et seq.), that the Declaration reflects the independent judgment of the City of San Diego as Lead Agency and that the information contained in said Declaration, together with any comments received during the public review process, has been reviewed and considered by the Development Services Department Staff in connection with the approval of the Project.

BE IT FURTHER RESOLVED, that the Development Services Department Staff finds on the basis of the entire record that project revisions now mitigate potentially significant effects

on the environment previously identified in the Initial Study, that there is no substantial evidence that the Project will have a significant effect on the environment, and therefore, that said Declaration is hereby adopted.

BE IT FURTHER RESOLVED, that pursuant to CEQA Section 21081.6, the Development Services Department Staff hereby adopts the Mitigation Monitoring and Reporting Program, or alterations to implement the changes to the Project as required by this Development Services Department Staff in order to mitigate or avoid significant effects on the environment, which is attached hereto as Exhibit A.

BE IT FURTHER RESOLVED, that the Declaration and other documents constituting the record of proceedings upon which the approval is based are available to the public at the office of the Development Services Department, 1222 First Avenue, San Diego, CA 92101.

BE IT FURTHER RESOLVED, that Development Services Department Staff is directed to file a Notice of Determination with the Clerk of the Board of Supervisors for the County of San Diego regarding the Project.

fw
By: 
William Fulton, Director, Planning, Neighborhoods & Economic Development

ATTACHMENT(S): Exhibit A, Mitigation Monitoring and Reporting Program

EXHIBIT A

MITIGATION MONITORING AND REPORTING PROGRAM SITE DEVELOPMENT PERMIT _____ SEWER GROUP 691-PROJECT NO. 284769

This Mitigation Monitoring and Reporting Program is designed to ensure compliance with Public Resources Code Section 21081.6 during implementation of mitigation measures. This program identifies at a minimum: the department responsible for the monitoring, what is to be monitored, how the monitoring shall be accomplished, the monitoring and reporting schedule, and completion requirements. A record of the Mitigation Monitoring and Reporting Program will be maintained at the offices of the Entitlements Division, 1222 First Avenue, Fifth Floor, San Diego, CA, 92101. All mitigation measures contained in the Mitigated Negative Declaration No. 284769 shall be made conditions of Site Development Permit No. _____ as may be further described below.

A. GENERAL REQUIREMENTS – PART I **Plan Check Phase (prior to permit issuance)**

1. Prior to the issuance of a Notice To Proceed (NTP) for a subdivision, or any construction permits, such as Demolition, Grading or Building, or beginning any construction related activity on-site, the Development Services Department (DSD) Director's Environmental Designee (ED) shall review and approve all Construction Documents (CD), (plans, specification, details, etc.) to ensure the MMRP requirements are incorporated into the design.
2. In addition, the ED shall verify that the MMRP Conditions/Notes that apply ONLY to the construction phases of this project are included VERBATIM, under the heading, "ENVIRONMENTAL/MITIGATION REQUIREMENTS."
3. These notes must be shown within the first three (3) sheets of the construction documents in the format specified for engineering construction document templates as shown on the City website:
<http://www.sandiego.gov/development-services/industry/standtemp.shtml>
4. The **TITLE INDEX SHEET** must also show on which pages the "Environmental/Mitigation Requirements" notes are provided.
5. **SURETY AND COST RECOVERY** – The Development Services Director or City Manager may require appropriate surety instruments or bonds from private Permit Holders to ensure the long term performance or implementation of required mitigation measures or programs. The City is authorized to recover its cost to offset the salary, overhead, and expenses for City personnel and programs to monitor qualifying projects.

B. GENERAL REQUIREMENTS – PART II **Post Plan Check (After permit issuance/Prior to start of construction)**

1. PRE CONSTRUCTION MEETING IS REQUIRED TEN (10) WORKING DAYS PRIOR TO BEGINNING ANY WORK ON THIS PROJECT. The PERMIT HOLDER/OWNER is responsible to arrange and perform this meeting by contacting the CITY RESIDENT ENGINEER (RE) of the Field Engineering Division and City staff from MITIGATION MONITORING COORDINATION (MMC). Attendees must also include the Permit holder's Representative(s), Job Site Superintendent and the following consultants:

Qualified Paleontological Monitor, Qualified Archaeologist, Native American Monitor and Qualified Biologist.

Note: Failure of all responsible Permit Holder's representatives and consultants to attend shall require an additional meeting with all parties present.

CONTACT INFORMATION:

- a) The PRIMARY POINT OF CONTACT is the RE at the **Field Engineering Division – 858-627-3200**
- b) For Clarification of ENVIRONMENTAL REQUIREMENTS, it is also required to call **RE and MMC at 858-627-3360**

2. MMRP COMPLIANCE: This Project, Project Tracking System (PTS) Number 284769 and /or Environmental Document Number 284769, shall conform to the mitigation requirements contained in the associated Environmental Document and implemented to the satisfaction of the DSD's Environmental Designee (MMC) and the City Engineer (RE). The requirements may not be reduced or changed but may be annotated (i.e. to explain when and how compliance is being met and location of verifying proof, etc.). Additional clarifying information may also be added to other relevant plan sheets and/or specifications as appropriate (i.e., specific locations, times of monitoring, methodology, etc

Note: Permit Holder's Representatives must alert RE and MMC if there are any discrepancies in the plans or notes, or any changes due to field conditions. All conflicts must be approved by RE and MMC BEFORE the work is performed.

3. OTHER AGENCY REQUIREMENTS: Evidence of compliance with all other agency requirements or permits shall be submitted to the RE and MMC for review and acceptance prior to the beginning of work or within one week of the Permit Holder obtaining documentation of those permits or requirements. Evidence shall include copies of permits, letters of resolution or other documentation issued by the responsible agency.

California Department of Fish and Wildlife: 1602 Streambed Alteration Agreement

US Army Corps of Engineers: Section 404 Clean Water Act Section Permit

Regional Water Quality Control Board: Section 401 Water Quality Certification

4. **MONITORING EXHIBITS:** All consultants are required to submit , to RE and MMC, a monitoring exhibit on a 11x17 reduction of the appropriate construction plan, such as site plan, grading, landscape, etc., marked to clearly show the specific areas including the **LIMIT OF WORK**, scope of that discipline’s work, and notes indicating when in the construction schedule that work will be performed. When necessary for clarification, a detailed methodology of how the work will be performed shall be included.

NOTE: Surety and Cost Recovery – When deemed necessary by the Development Services Director or City Manager, additional surety instruments or bonds from the private Permit Holder may be required to ensure the long term performance or implementation of required mitigation measures or programs. The City is authorized to recover its cost to offset the salary, overhead, and expenses for City personnel and programs to monitor qualifying projects.

5. **OTHER SUBMITTALS AND INSPECTIONS:** The Permit Holder/Owner’s representative shall submit all required documentation, verification letters, and requests for all associated inspections to the RE and MMC for approval per the following schedule:

Document Submittal/Inspection Checklist

<i>Issue Area</i>	<i>Document submittal</i>	<i>Assoc Inspection/Approvals lNotes</i>
General	Consultant Qualification Letters	Prior to Pre-construction Meeting
General	Consultant Const. Monitoring Exhibits	Prior to or at the Pre-Construction meeting
Biology	Biologist Limit of Work Verification	Limit of Work inspection
Paleontology	Paleontology Reports	Paleontology site observation
Archaeology	Archaeology Reports	Archaeology/Historic site observation
Biology	Biology Reports	Biology/Habitat Restoration inspection
Land Use	Land Use Adjacency issues CSVs	Land Use Adjacency issue site observations

C. SPECIFIC MMRP ISSUE AREA CONDITIONS/REQUIREMENTS

BIOLOGICAL RESOURCE PROTECTION DURING CONSTRUCTION

I. Prior to Construction

- A. **Biologist Verification** -The owner/permittee shall provide a letter to the City’s Mitigation Monitoring Coordination (MMC) section stating that a Project Biologist (Qualified Biologist) as defined in the City of San Diego’s Biological Guidelines (2012), has been retained to implement the project’s biological monitoring program. The letter shall include the names and contact information of all persons involved in the biological monitoring of the project.
- B. **Preconstruction Meeting** - The Qualified Biologist shall attend the preconstruction meeting, discuss the project’s biological monitoring program, and arrange to perform any follow up mitigation measures and reporting including site-specific monitoring, restoration or revegetation, and additional fauna/flora surveys/salvage.
- C. **Biological Documents** - The Qualified Biologist shall submit all required documentation to MMC verifying that any special mitigation reports including but not limited to, maps,

plans, surveys, survey timelines, or buffers are completed or scheduled per City Biology Guidelines, Multiple Species Conservation Program (MSCP), Environmentally Sensitive Lands Ordinance (ESL), project permit conditions; California Environmental Quality Act (CEQA); endangered species acts (ESAs); and/or other local, state or federal requirements.

- D. **BCME** -The Qualified Biologist shall present a Biological Construction Mitigation/Monitoring Exhibit (BCME) which includes the biological documents in C above. In addition, include: restoration/revegetation plans, plant salvage/relocation requirements (e.g., coastal cactus wren plant salvage, burrowing owl exclusions, etc.), avian or other wildlife surveys/survey schedules (including general avian nesting and USFWS protocol), timing of surveys, wetland buffers, avian construction avoidance areas/noise buffers/ barriers, other impact avoidance areas, and any subsequent requirements determined by the Qualified Biologist and the City ADD/MMC. The BCME shall include a site plan, written and graphic depiction of the project's biological mitigation/monitoring program, and a schedule. The BCME shall be approved by MMC and referenced in the construction documents.
- E. **E. Avian Protection Requirements** - To avoid any direct impacts to raptors and/or any native/migratory birds, removal of habitat that supports active nests in the proposed area of disturbance should occur outside of the breeding season for these species (February 1 to September 15). If removal of habitat in the proposed area of disturbance must occur during the breeding season, the Qualified Biologist shall conduct a pre-construction survey to determine the presence or absence of nesting birds on the proposed area of disturbance. The pre-construction survey shall be conducted within 10 calendar days prior to the start of construction activities (including removal of vegetation). The applicant shall submit the results of the pre-construction survey to City DSD for review and approval prior to initiating any construction activities. If nesting birds are detected, a letter report or mitigation plan in conformance with the City's Biology Guidelines and applicable State and Federal Law (i.e. appropriate follow up surveys, monitoring schedules, construction and noise barriers/buffers, etc.) shall be prepared and include proposed measures to be implemented to ensure that take of birds or eggs or disturbance of breeding activities is avoided. The report or mitigation plan shall be submitted to the City for review and approval and implemented to the satisfaction of the City. The City's MMC Section or RE, and Biologist shall verify and approve that all measures identified in the report or mitigation plan are in place prior to and/or during construction.
- F. **Resource Delineation** - Prior to construction activities, the Qualified Biologist shall supervise the placement of orange construction fencing or equivalent along the limits of disturbance adjacent to sensitive biological habitats and verify compliance with any other project conditions as shown on the BCME. This phase shall include flagging plant specimens and delimiting buffers to protect sensitive biological resources (e.g., habitats/flora & fauna species, including nesting birds) during construction. Appropriate steps/care should be taken to minimize attraction of nest predators to the site.
- G. **Education** -Prior to commencement of construction activities, the Qualified Biologist shall meet with the owner/permittee or designee and the construction crew and conduct an on-site educational session regarding the need to avoid impacts outside of the approved construction area and to protect sensitive flora and fauna (e.g., explain the avian

and wetland buffers, flag system for removal of invasive species or retention of sensitive plants, and clarify acceptable access routes/methods and staging areas, etc.).

II. During Construction

- A. **Monitoring**- All construction (including access/staging areas) shall be restricted to areas previously identified, proposed for development/staging, or previously disturbed as shown on “Exhibit A” and/or the BCME. The Qualified Biologist shall monitor construction activities as needed to ensure that construction activities do not encroach into biologically sensitive areas, or cause other similar damage, and that the work plan has been amended to accommodate any sensitive species located during the pre-construction surveys. In addition, the Qualified Biologist shall document field activity via the Consultant Site Visit Record (CSV). The CSV shall be e-mailed to MMC on the 1st day of monitoring, the 1st week of each month, the last day of monitoring, and immediately in the case of any undocumented condition or discovery.
- B. **Subsequent Resource Identification** - The Qualified Biologist shall note/act to prevent any new disturbances to habitat, flora, and/or fauna onsite (e.g., flag plant specimens for avoidance during access, etc). If active nests or other previously unknown sensitive resources are detected, all project activities that directly impact the resource shall be delayed until species specific local, state or federal regulations have been determined and applied by the Qualified Biologist.

III. Post Construction Measures

- A. In the event that impacts exceed previously allowed amounts, additional impacts shall be mitigated in accordance with City Biology Guidelines, ESL and MSCP, State CEQA, and other applicable local, state and federal law. The Qualified Biologist shall submit a final BCME/report to the satisfaction of the City ADD/MMC within 30 days of construction completion.

GENERAL NESTING BIRD MITIGATION

BIOLOGY (General Birds)

To avoid any direct impacts to raptors and/or any native/migratory birds, removal of habitat that supports active nests in the proposed area of disturbance should occur outside of the breeding season for these species (February 1 to September 15). If removal of habitat in the proposed area of disturbance must occur during the breeding season, the Qualified Biologist shall conduct a pre-construction survey to determine the presence or absence of nesting birds on the proposed area of disturbance. The pre-construction (precon) survey shall be conducted within 10 calendar days prior to the start of construction activities (including removal of vegetation). The applicant shall submit the results of the precon survey to City DSD for review and approval prior to initiating any construction activities. If nesting birds are detected, a letter report or mitigation plan in conformance with the City’s Biology Guidelines and applicable State and Federal Law (i.e. appropriate follow up surveys, monitoring schedules, construction and noise barriers/buffers, etc.) shall be prepared and include proposed measures to be implemented to ensure that take of birds or eggs or disturbance of breeding activities is avoided. The

report or mitigation plan shall be submitted to the City DSD for review and approval and implemented to the satisfaction of the City. The City's MMC Section or RE, and Biologist shall verify and approve that all measures identified in the report or mitigation plan are in place prior to and/or during construction. If nesting birds are not detected during the precon survey, no further mitigation is required.

LAND USE (MSCP/MHPA LAND USE ADJACENCY)

LUAG 1: In order to avoid potentially significant indirect impacts to Multi-Habitat Planning Areas (MHPA) areas, the following mitigation measures shall be implemented by the project Applicant/Permitee. This mitigation measure shall be utilized in conjunction with Mitigation Measure BIO-1. Compliance with the mitigation measures shall be the responsibility of the Applicant/Permitee:

- I. Prior to issuance of any construction permit or notice to proceed, DSD/ LDR, and/or MSCP staff shall verify the Applicant has accurately represented the project's design in or on the Construction Documents (CD's/CD's consist of Construction Plan Sets for Private Projects and Contract Specifications for Public Projects) are in conformance with the associated discretionary permit conditions and Exhibit "A", and also the City's Multi-Species Conservation Program (MSCP) Multi-Habitat Planning Area (MHPA) Land Use Adjacency Guidelines. The applicant shall provide an implementing plan and include references on/in CD's of the following:
 - A. **Grading/Land Development/MHPA Boundaries** - MHPA boundaries on-site and adjacent properties shall be delineated on the CDs. DSD Planning and/or MSCP staff shall ensure that all grading is included within the development footprint, specifically manufactured slopes, disturbance, and development within or adjacent to the MHPA. For projects within or adjacent to the MHPA, all manufactured slopes associated with site development shall be included within the development footprint.
 - B. **Drainage** - All new and proposed parking lots and developed areas in and adjacent to the MHPA shall be designed so they do not drain directly into the MHPA. All developed and paved areas must prevent the release of toxins, chemicals, petroleum products, exotic plant materials prior to release by incorporating the use of filtration devices, planted swales and/or planted detention/desiltation basins, or other approved permanent methods that are designed to minimize negative impacts, such as excessive water and toxins into the ecosystems of the MHPA.
 - C. **Toxics/Project Staging Areas/Equipment Storage** - Projects that use chemicals or generate by-products such as pesticides, herbicides, and animal waste, and other substances that are potentially toxic or impactive to native habitats/flora/fauna (including water) shall incorporate measures to reduce impacts caused by the application and/or drainage of such materials into the MHPA. No trash, oil, parking, or other construction/development-related material/activities shall be allowed outside any approved construction limits. Where

applicable, this requirement shall be incorporated into leases on publicly-owned property when applications for renewal occur. Provide a note in/on the CD's that states: "All construction related activity that may have potential for leakage or intrusion shall be monitored by the Qualified Biologist/Owners Representative or Resident Engineer to ensure there is no impact to the MHPA."

- D. **Invasives**- No invasive non-native plant species shall be introduced into areas within or adjacent to the MHPA.
- E. **Noise** - Due to the site's location adjacent to or within the MHPA where the Qualified Biologist has identified potential nesting habitat for listed avian species, construction noise that exceeds the maximum levels allowed shall be avoided during the breeding seasons for the following: California Gnatcatcher(3/1-8/15) If construction is proposed during the breeding season for the species, U.S.Fish and Wildlife Service protocol surveys shall be required in order to determine species presence/absence. If protocol surveys are not conducted in suitable habitat during the breeding season for the aforementioned listed species, presence shall be assumed with implementation of noise attenuation and biological monitoring.

When applicable (i.e., habitat is occupied or if presence of the covered species is assumed), adequate noise reduction measures shall be incorporated as follows:

COASTAL CALIFORNIA GNATCATCHER (Federally Threatened)

Prior to the issuance of any grading permit the City Manager (or appointed designee) shall verify that the Multi-Habitat Planning Area (MHPA) boundaries and the following project requirements regarding the coastal California gnatcatcher are shown on the construction plans:

No clearing, grubbing, grading, or other construction activities shall occur between March 1 and August 15, the breeding season of the coastal California gnatcatcher, until the following requirements have been met to the satisfaction of the City Manager:

- A. A Qualified Biologist (possessing a valid Endangered Species Act Section 10(a)(1)(a) Recovery Permit) shall survey those habitat areas within the MHPA that would be subject to construction noise levels exceeding 60 decibels [dB(A)] hourly average for the presence of the coastal California gnatcatcher. Surveys for the coastal California gnatcatcher shall be conducted pursuant to the protocol survey guidelines established by the U.S. Fish and Wildlife Service within the breeding season prior to the commencement of any construction. If coastal California gnatcatchers are present, then the following conditions must be met:
 - I. Between March 1 and August 15, no clearing, grubbing, or grading of occupied coastal California gnatcatcher habitat shall be permitted.

Areas restricted from such activities shall be staked or fenced under the supervision of a Qualified Biologist; and

- II. Between March 1 and August 15, no construction activities shall occur within any portion of the site where construction activities would result in noise levels exceeding 60 dB(A) hourly average at the edge of occupied gnatcatcher habitat. An analysis showing that noise generated by construction activities would not exceed 60 dB(A) hourly average at the edge of occupied habitat must be completed by a Qualified Acoustician (possessing current noise engineer license or registration with monitoring noise level experience with listed animal species) and approved by the City Manager at least two weeks prior to the commencement of construction activities. Prior to the commencement of construction activities during the breeding season, areas restricted from such activities shall be staked or fenced under the supervision of a Qualified Biologist; or
- III. At least two weeks prior to the commencement of construction activities, under the direction of a qualified acoustician, noise attenuation measures (e.g., berms, walls) shall be implemented to ensure that noise levels resulting from construction activities will not exceed 60 dB(A) hourly average at the edge of habitat occupied by the coastal California gnatcatcher. Concurrent with the commencement of construction activities and the construction of necessary noise attenuation facilities, noise monitoring* shall be conducted at the edge of the occupied habitat area to ensure that noise levels do not exceed 60 dB(A) hourly average. If the noise attenuation techniques implemented are determined to be inadequate by the Qualified Acoustician or biologist, then the associated construction activities shall cease until such time that adequate noise attenuation is achieved or until the end of the breeding season (August 16).

* Construction noise monitoring shall continue to be monitored at least twice weekly on varying days, or more frequently depending on the construction activity, to verify that noise levels at the edge of occupied habitat are maintained below 60 dB(A) hourly average or to the ambient noise level if it already exceeds 60 dB(A) hourly average. If not, other measures shall be implemented in consultation with the biologist and the City Manager, as necessary, to reduce noise levels to below 60 dB(A) hourly average or to the ambient noise level if it already exceeds 60 dB(A) hourly average. Such measures may include, but are not limited to, limitations on the placement of construction equipment and the simultaneous use of equipment.

- B. If coastal California gnatcatchers are not detected during the protocol survey, the Qualified Biologist shall submit substantial evidence to the

City Manager and applicable resource agencies which demonstrates whether or not mitigation measures such as noise walls are necessary between March 1 and August 15 as follows:

- I. If this evidence indicates the potential is high for coastal California gnatcatcher to be present based on historical records or site conditions, then condition A.III shall be adhered to as specified above.
- II. If this evidence concludes that no impacts to this species are anticipated, no mitigation measures would be necessary.

I. Prior to Start of Construction

Preconstruction Meeting – The Qualified Biologist/Owners Representative shall incorporate all MHPA construction related requirements, into the project’s Biological Monitoring Exhibit (BME).

The Qualified Biologist/Owners Representative is responsible to arrange and perform a focused pre-con with all contractors, subcontractors, and all workers involved in grading or other construction activities that discusses the sensitive nature of the adjacent sensitive biological resources.

II. During Construction

The Qualified Biologist/Owners Representative shall verify that all construction related activities taking place within or adjacent to the MHPA are consistent with the CDs, the MSCP Land Use Adjacency Guidelines. The Qualified Biologist/Owners Representative shall monitor and ensure that the conditions as identified above under Section I, Prior to Permit Issuance, are implemented.

III. Post Construction

Preparation and Submittal of Monitoring Report – The Qualified Biologist/Owners Representative shall submit a final biological monitoring report to the RE/MMC within 30 days of the completion of construction that requires monitoring. The report shall incorporate the results of the MMRP/MSCP requirements per the construction documents and the BME to the satisfaction of RE/MMC.

HISTORICAL RESOURCES (ARCHAEOLOGICAL)

I. Prior to Permit Issuance or Bid Opening/Bid Award

A. Entitlements Plan Check

1. Prior to permit issuance or Bid Opening/Bid Award, whichever is applicable, the Assistant Deputy Director (ADD) Environmental designee shall verify that the requirements for Archaeological Monitoring and Native American monitoring have been noted on the applicable construction documents through the plan check process.

- B. Letters of Qualification have been submitted to ADD
 - 1. Prior to Bid Award, the applicant shall submit a letter of verification to Mitigation Monitoring Coordination (MMC) identifying the Principal Investigator (PI) for the project and the names of all persons involved in the archaeological monitoring program, as defined in the City of San Diego Historical Resources Guidelines (HRG). If applicable, individuals involved in the archaeological monitoring program must have completed the 40-hour HAZWOPER training with certification documentation.
 - 2. MMC will provide a letter to the applicant confirming the qualifications of the PI and all persons involved in the archaeological monitoring of the project meet the qualifications established in the HRG.
 - 3. Prior to the start of work, the applicant must obtain written approval from MMC for any personnel changes associated with the monitoring program.

II. Prior to Start of Construction

A. Verification of Records Search

- 1. The PI shall provide verification to MMC that a site specific records search (1/4 mile radius) has been completed. Verification includes, but is not limited to a copy of a confirmation letter from South Coastal Information Center, or, if the search was in-house, a letter of verification from the PI stating that the search was completed.
- 2. The letter shall introduce any pertinent information concerning expectations and probabilities of discovery during trenching and/or grading activities.
- 3. The PI may submit a detailed letter to MMC requesting a reduction to the 1/4 mile radius.

B. PI Shall Attend Precon Meetings

- 1. Prior to beginning any work that requires monitoring; the Applicant shall arrange a Precon Meeting that shall include the PI, Native American consultant/monitor (where Native American resources may be impacted), Construction Manager (CM) and/or Grading Contractor, Resident Engineer (RE), Building Inspector (BI), if appropriate, and MMC. The qualified Archaeologist and Native American Monitor shall attend any grading/excavation related Precon Meetings to make comments and/or suggestions concerning the Archaeological Monitoring program with the Construction Manager and/or Grading Contractor.
 - a. If the PI is unable to attend the Precon Meeting, the Applicant shall schedule a focused Precon Meeting with MMC, the PI, RE, CM or BI, if appropriate, prior to the start of any work that requires monitoring.
- 2. Acknowledgement of Responsibility for Curation (CIP or Other Public Projects)
The applicant shall submit a letter to MMC acknowledging their responsibility for the cost of curation associated with all phases of the archaeological monitoring program.
- 3. Identify Areas to be Monitored
 - a. Prior to the start of any work that requires monitoring, the PI shall submit an Archaeological Monitoring Exhibit (AME) (with verification that the AME has been reviewed and approved by the Native American consultant/monitor when Native American resources may be impacted) based on the appropriate

- construction documents (reduced to 11x17) to MMC identifying the areas to be monitored including the delineation of grading/excavation limits.
- b. The AME shall be based on the results of a site specific records search as well as information regarding the age of existing pipelines, laterals and associated appurtenances and/or any known soil conditions (native or formation).
 - c. MMC shall notify the PI that the AME has been approved.
4. When Monitoring Will Occur
- a. Prior to the start of any work, the PI shall also submit a construction schedule to MMC through the RE indicating when and where monitoring will occur.
 - b. The PI may submit a detailed letter to MMC prior to the start of work or during construction requesting a modification to the monitoring program. This request shall be based on relevant information such as review of final construction documents which indicate conditions such as age of existing pipe to be replaced, depth of excavation and/or site graded to bedrock, etc., which may reduce or increase the potential for resources to be present.
5. Approval of AME and Construction Schedule
- After approval of the AME by MMC, the PI shall submit to MMC written authorization of the AME and Construction Schedule from the CM.

III. During Construction

A. Monitor Shall be Present During Grading/Excavation/Trenching

1. The Archaeological Monitor shall be present full-time during all soil disturbing and grading/excavation/trenching activities which could result in impacts to archaeological resources as identified on the AME. **The Construction Manager is responsible for notifying the RE, PI, and MMC of changes to any construction activities such as in the case of a potential safety concern within the area being monitored. In certain circumstances OSHA safety requirements may necessitate modification of the AME.**
2. The Native American consultant/monitor shall determine the extent of their presence during soil disturbing and grading/excavation/trenching activities based on the AME and provide that information to the PI and MMC. If prehistoric resources are encountered during the Native American consultant/monitor's absence, work shall stop and the Discovery Notification Process detailed in Section III.B-C and IV.A-D shall commence.
3. The PI may submit a detailed letter to MMC during construction requesting a modification to the monitoring program when a field condition such as modern disturbance post-dating the previous grading/trenching activities, presence of fossil formations, or when native soils are encountered that may reduce or increase the potential for resources to be present.
4. The archaeological and Native American consultant/monitor shall document field activity via the Consultant Site Visit Record (CSVSR). The CSVSR's shall be faxed by the CM to the RE the first day of monitoring, the last day of monitoring, monthly (**Notification of Monitoring Completion**), and in the case of ANY discoveries. The RE shall forward copies to MMC.

B. Discovery Notification Process

1. In the event of a discovery, the Archaeological Monitor shall direct the contractor to temporarily divert all soil disturbing activities, including but not limited to digging, trenching, excavating or grading activities in the area of discovery and in the area reasonably suspected to overlay adjacent resources and immediately notify the RE or BI, as appropriate.
2. The Monitor shall immediately notify the PI (unless Monitor is the PI) of the discovery.
3. The PI shall immediately notify MMC by phone of the discovery, and shall also submit written documentation to MMC within 24 hours by fax or email with photos of the resource in context, if possible.
4. No soil shall be exported off-site until a determination can be made regarding the significance of the resource specifically if Native American resources are encountered.

C. Determination of Significance

1. The PI and Native American consultant/monitor, where Native American resources are discovered shall evaluate the significance of the resource. If Human Remains are involved, follow protocol in Section IV below.
 - a. The PI shall immediately notify MMC by phone to discuss significance determination and shall also submit a letter to MMC indicating whether additional mitigation is required.
 - b. If the resource is significant, the PI shall submit an Archaeological Data Recovery Program (ADRP) and obtain written approval of the program from MMC, CM and RE. ADRP and any mitigation must be approved by MMC, RE and/or CM before ground disturbing activities in the area of discovery will be allowed to resume. **Note: If a unique archaeological site is also an historical resource as defined in CEQA Section 15064.5, then the limits on the amount(s) that a project applicant may be required to pay to cover mitigation costs as indicated in CEQA Section 21083.2 shall not apply.**
 - (1). Note: For pipeline trenching and other linear projects in the public Right-of-Way, the PI shall implement the Discovery Process for Pipeline Trenching projects identified below under "D."
 - c. If the resource is not significant, the PI shall submit a letter to MMC indicating that artifacts will be collected, curated, and documented in the Final Monitoring Report. The letter shall also indicate that that no further work is required.
 - (1). Note: For Pipeline Trenching and other linear projects in the public Right-of-Way, if the deposit is limited in size, both in length and depth; the information value is limited and is not associated with any other resource; and there are no unique features/artifacts associated with the deposit, the discovery should be considered not significant.
 - (2). Note, for Pipeline Trenching and other linear projects in the public Right-of-Way, if significance cannot be determined, the Final Monitoring Report and Site Record (DPR Form 523A/B) shall identify the discovery as Potentially Significant.

D. Discovery Process for Significant Resources - Pipeline Trenching and other Linear Projects in the Public Right-of-Way

The following procedure constitutes adequate mitigation of a significant discovery encountered during pipeline trenching activities or for other linear project types within the Public Right-of-Way including but not limited to excavation for jacking pits, receiving pits, laterals, and manholes to reduce impacts to below a level of significance:

1. Procedures for documentation, curation and reporting
 - a. One hundred percent of the artifacts within the trench alignment and width shall be documented in-situ, to include photographic records, plan view of the trench and profiles of side walls, recovered, photographed after cleaning and analyzed and curated. The remainder of the deposit within the limits of excavation (trench walls) shall be left intact.
 - b. The PI shall prepare a Draft Monitoring Report and submit to MMC via the RE as indicated in Section VI-A.
 - c. The PI shall be responsible for recording (on the appropriate State of California Department of Park and Recreation forms-DPR 523 A/B) the resource(s) encountered during the Archaeological Monitoring Program in accordance with the City's Historical Resources Guidelines. The DPR forms shall be submitted to the South Coastal Information Center for either a Primary Record or SDI Number and included in the Final Monitoring Report.
 - d. The Final Monitoring Report shall include a recommendation for monitoring of any future work in the vicinity of the resource.

IV. Discovery of Human Remains

If human remains are discovered, work shall halt in that area and no soil shall be exported off-site until a determination can be made regarding the provenance of the human remains; and the following procedures as set forth in CEQA Section 15064.5(e), the California Public Resources Code (Sec. 5097.98) and State Health and Safety Code (Sec. 7050.5) shall be undertaken:

A. Notification

1. Archaeological Monitor shall notify the RE or BI as appropriate, MMC, and the PI, if the Monitor is not qualified as a PI. MMC will notify the appropriate Senior Planner in the Environmental Analysis Section (EAS) of the Development Services Department to assist with the discovery notification process.
2. The PI shall notify the Medical Examiner after consultation with the RE, either in person or via telephone.

B. Isolate discovery site

1. Work shall be directed away from the location of the discovery and any nearby area reasonably suspected to overlay adjacent human remains until a determination can be made by the Medical Examiner in consultation with the PI concerning the provenience of the remains.
2. The Medical Examiner, in consultation with the PI, will determine the need for a field examination to determine the provenience.

3. If a field examination is not warranted, the Medical Examiner will determine with input from the PI, if the remains are or are most likely to be of Native American origin.
- C. If Human Remains **ARE** determined to be Native American
1. The Medical Examiner will notify the Native American Heritage Commission (NAHC) within 24 hours. By law, **ONLY** the Medical Examiner can make this call.
 2. NAHC will immediately identify the person or persons determined to be the Most Likely Descendent (MLD) and provide contact information.
 3. The MLD will contact the PI within 24 hours or sooner after the Medical Examiner has completed coordination, to begin the consultation process in accordance with CEQA Section 15064.5(e), the California Public Resources and Health & Safety Codes.
 4. The MLD will have 48 hours to make recommendations to the property owner or representative, for the treatment or disposition with proper dignity, of the human remains and associated grave goods.
 5. Disposition of Native American Human Remains will be determined between the MLD and the PI, and, if:
 - a. The NAHC is unable to identify the MLD, OR the MLD failed to make a recommendation within 48 hours after being notified by the Commission, OR;
 - b. The landowner or authorized representative rejects the recommendation of the MLD and mediation in accordance with PRC 5097.94 (k) by the NAHC fails to provide measures acceptable to the landowner, THEN
 - c. To protect these sites, the landowner shall do one or more of the following:
 - (1) Record the site with the NAHC;
 - (2) Record an open space or conservation easement; or
 - (3) Record a document with the County.
 - d. Upon the discovery of multiple Native American human remains during a ground disturbing land development activity, the landowner may agree that additional conferral with descendants is necessary to consider culturally appropriate treatment of multiple Native American human remains. Culturally appropriate treatment of such a discovery may be ascertained from review of the site utilizing cultural and archaeological standards. Where the parties are unable to agree on the appropriate treatment measures the human remains and items associated and buried with Native American human remains shall be reinterred with appropriate dignity, pursuant to Section 5.c., above.
- D. If Human Remains are **NOT** Native American
1. The PI shall contact the Medical Examiner and notify them of the historic era context of the burial.
 2. The Medical Examiner will determine the appropriate course of action with the PI and City staff (PRC 5097.98).
 3. If the remains are of historic origin, they shall be appropriately removed and conveyed to the San Diego Museum of Man for analysis. The decision for internment of the human remains shall be made in consultation with MMC, EAS, the applicant/landowner, any known descendant group, and the San Diego Museum of Man.

V. Night and/or Weekend Work

- A. If night and/or weekend work is included in the contract
 - 1. When night and/or weekend work is included in the contract package, the extent and timing shall be presented and discussed at the precon meeting.
 - 2. The following procedures shall be followed.
 - a. No Discoveries
In the event that no discoveries were encountered during night and/or weekend work, the PI shall record the information on the CSVR and submit to MMC via fax by 8AM of the next business day.
 - b. Discoveries
All discoveries shall be processed and documented using the existing procedures detailed in Sections III - During Construction, and IV – Discovery of Human Remains. Discovery of human remains shall always be treated as a significant discovery.
 - c. Potentially Significant Discoveries
If the PI determines that a potentially significant discovery has been made, the procedures detailed under Section III - During Construction and IV-Discovery of Human Remains shall be followed.
 - d. The PI shall immediately contact the RE and MMC, or by 8AM of the next business day to report and discuss the findings as indicated in Section III-B, unless other specific arrangements have been made.
- B. If night and/or weekend work becomes necessary during the course of construction
 - 1. The Construction Manager shall notify the RE, or BI, as appropriate, a minimum of 24 hours before the work is to begin.
 - 2. The RE, or BI, as appropriate, shall notify MMC immediately.
- C. All other procedures described above shall apply, as appropriate.

VI. Post Construction

- A. Submittal of Draft Monitoring Report
 - 1. The PI shall submit two copies of the Draft Monitoring Report (even if negative), prepared in accordance with the Historical Resources Guidelines (Appendix C/D) which describes the results, analysis, and conclusions of all phases of the Archaeological Monitoring Program (with appropriate graphics) to MMC via the RE for review and approval within 90 days following the completion of monitoring. **It should be noted that if the PI is unable to submit the Draft Monitoring Report within the allotted 90-day timeframe as a result of delays with analysis, special study results or other complex issues, a schedule shall be submitted to MMC establishing agreed due dates and the provision for submittal of monthly status reports until this measure can be met.**
 - a. For significant archaeological resources encountered during monitoring, the Archaeological Data Recovery Program or Pipeline Trenching Discovery Process shall be included in the Draft Monitoring Report.
 - b. Recording Sites with State of California Department of Parks and Recreation
The PI shall be responsible for recording (on the appropriate State of California Department of Park and Recreation forms-DPR 523 A/B) any significant or potentially significant resources encountered during the

Archaeological Monitoring Program in accordance with the City's Historical Resources Guidelines, and submittal of such forms to the South Coastal Information Center with the Final Monitoring Report.

2. MMC shall return the Draft Monitoring Report to the PI via the RE for revision or, for preparation of the Final Report.
 3. The PI shall submit revised Draft Monitoring Report to MMC via the RE for approval.
 4. MMC shall provide written verification to the PI of the approved report.
 5. MMC shall notify the RE or BI, as appropriate, of receipt of all Draft Monitoring Report submittals and approvals.
- B. Handling of Artifacts
1. The PI shall be responsible for ensuring that all cultural remains collected are cleaned and catalogued
 2. The PI shall be responsible for ensuring that all artifacts are analyzed to identify function and chronology as they relate to the history of the area; that faunal material is identified as to species; and that specialty studies are completed, as appropriate.
- C. Curation of artifacts: Accession Agreement and Acceptance Verification
1. The PI shall be responsible for ensuring that all artifacts associated with the survey, testing and/or data recovery for this project are permanently curated with an appropriate institution. This shall be completed in consultation with MMC and the Native American representative, as applicable.
 2. When applicable to the situation, the PI shall include written verification from the Native American consultant/monitor indicating that Native American resources were treated in accordance with state law and/or applicable agreements. If the resources were reinterred, verification shall be provided to show what protective measures were taken to ensure no further disturbance occurs in accordance with Section IV – Discovery of Human Remains, Subsection C.
 3. The PI shall submit the Accession Agreement and catalogue record(s) to the RE or BI, as appropriate for donor signature with a copy submitted to MMC.
 4. The RE or BI, as appropriate shall obtain signature on the Accession Agreement and shall return to PI with copy submitted to MMC.
 5. The PI shall include the Acceptance Verification from the curation institution in the Final Monitoring Report submitted to the RE or BI and MMC.
- D. Final Monitoring Report(s)
1. The PI shall submit one copy of the approved Final Monitoring Report to the RE or BI as appropriate, and one copy to MMC (even if negative), within 90 days after notification from MMC of the approved report.
 2. The RE shall, in no case, issue the Notice of Completion until receiving a copy of the approved Final Monitoring Report from MMC which includes the Acceptance Verification from the curation institution.

I:\AI\LDR\EAS\MMRP\Archae Public_101211.doc

HISTORICAL RESOURCES (BUILT ENVIRONMENT)

The project is located within the Burlingame Historic District, which consists of approximately 40 acres of land and has boundaries of; Switzer Canyon to the north, the

alley between Kalmia and Juniper Streets to the south, 30th Street to the west, and 32nd Street to the east.

All work within the District boundary must be consistent with the City's Historical Resources Regulations, the U.S. Secretary of the Interior's Standards and the North Park / Greater Golden Hill Community Planned District Design Guidelines. The following mitigation measures are required within the District boundaries and shall ensure consistency with these regulations, Standards and guidelines.

- A. Prior to beginning any work at the site, a Pre Construction meeting that includes Historic Resources and MMC staff shall be held at the project site to review these mitigation measures and requirements within the District boundary.
- B. A Historic Sidewalk Stamp Inventory prepared by a qualified historic consultant or archaeologist and approved by HRB staff is required prior to the Pre-Construction (Pre-Con) meeting. The Inventory shall include photo documentation of all existing stamps within the project area keyed to a project site plan.
- C. Existing sidewalk stamps shall be preserved in place. Where existing sidewalk stamps must be impacted to accommodate right-of-way improvements, the following actions are required:
 1. A mold of the sidewalk stamp will be made to allow reconstruction of the stamp if destroyed during relocation.
 2. The sidewalk stamp shall be saw-cut to preserve the stamp in its entirety; relocated as near as possible to the original location; and set in the same orientation.
 3. If the sidewalk stamp is destroyed during relocation, a new sidewalk stamp shall be made from the mold taken and relocated as near as possible to the original location and set in the same orientation.
- D. No new sidewalk stamps shall be added by any contractor working on the project.
- E. Existing historic sidewalk, parkway and street widths shall be maintained. Any work that requires alteration of these widths shall be approved by Historic Resources staff.
- F. Existing historic curb heights and appearance shall be maintained. Any work that requires alteration of the existing height or appearance shall be approved by Historic Resources staff.
- G. Sections of sidewalk which may be impacted by the project shall be replaced in-kind to match the historic color, texture and scoring pattern of the original sidewalks. If the original color, scoring pattern or texture is not present at the location of the impact, the historically appropriate color, texture and scoring pattern found throughout the district shall be used.
- H. Truncated domes used at corner curb ramps shall be dark gray in color. An Americans with Disabilities Act Contrast Study will be required for the purpose of installing ramps that are other colors than the standard yellow in order to be consistent with the requirements of the District
- I. Existing historic lighting, such as acorn lighting shall remain. New lighting shall be consistent with existing lighting fixtures, or fixtures specified in any applicable District Design Guidelines.

- J. Existing mature street trees shall remain. New street trees shall be consistent with the prevalent mature species in the District and/or species specified in any applicable District Design Guidelines.
- K. Any walls located within the right-of-way or on private property are considered historic and may not be impacted without prior review and approval by Historic Resources staff.

PALEONTOLOGICAL RESOURCES

I. Prior to Permit Issuance or Bid Opening/Bid Award

A. Entitlements Plan Check

- 1. Prior to permit issuance or Bid Opening/Bid Award, whichever is applicable, the Assistant Deputy Director (ADD) Environmental designee shall verify that the requirements for Paleontological Monitoring have been noted on the appropriate construction documents.

B. Letters of Qualification have been submitted to ADD

- 1. Prior to Bid Award, the applicant shall submit a letter of verification to Mitigation Monitoring Coordination (MMC) identifying the Principal Investigator (PI) for the project and the names of all persons involved in the paleontological monitoring program, as defined in the City of San Diego Paleontology Guidelines.
- 2. MMC will provide a letter to the applicant confirming the qualifications of the PI and all persons involved in the paleontological monitoring of the project.
- 3. Prior to the start of work, the applicant shall obtain approval from MMC for any personnel changes associated with the monitoring program.

II. Prior to Start of Construction

A. Verification of Records Search

- 1. The PI shall provide verification to MMC that a site specific records search has been completed. Verification includes, but is not limited to a copy of a confirmation letter from San Diego Natural History Museum, other institution or, if the search was in-house, a letter of verification from the PI stating that the search was completed.
- 2. The letter shall introduce any pertinent information concerning expectations and probabilities of discovery during trenching and/or grading activities.

B. PI Shall Attend Precon Meetings

- 1. Prior to beginning any work that requires monitoring, the Applicant shall arrange a Precon Meeting that shall include the PI, Construction Manager (CM) and/or Grading Contractor, Resident Engineer (RE), Building Inspector (BI), if appropriate, and MMC. The qualified paleontologist shall attend any grading/excavation related Precon Meetings to make comments and/or suggestions concerning the Paleontological Monitoring program with the Construction Manager and/or Grading Contractor.
 - a. If the PI is unable to attend the Precon Meeting, the Applicant shall schedule a focused Precon Meeting with MMC, the PI, RE, CM or BI, if appropriate, prior to the start of any work that requires monitoring.

2. Acknowledgement of Responsibility for Curation (CIP or Other Public Projects)
The applicant shall submit a letter to MMC acknowledging their responsibility for the cost of curation associated with all phases of the paleontological monitoring program.
3. Identify Areas to be Monitored
 - a. Prior to the start of any work that requires monitoring, the PI shall submit a Paleontological Monitoring Exhibit (PME) based on the appropriate construction documents (reduced to 11x17) to MMC for approval identifying the areas to be monitored including the delineation of grading/excavation limits. Monitoring shall begin at depths below 10 feet from existing grade or as determined by the PI in consultation with MMC. The determination shall be based on site specific records search data which supports monitoring at depths less than ten feet.
 - b. The PME shall be based on the results of a site specific records search as well as information regarding existing known soil conditions (native or formation).
 - c. MMC shall notify the PI that the PME has been approved.
4. When Monitoring Will Occur
 - a. Prior to the start of any work, the PI shall also submit a construction schedule to MMC through the RE indicating when and where monitoring will occur.
 - b. The PI may submit a detailed letter to MMC prior to the start of work or during construction requesting a modification to the monitoring program. This request shall be based on relevant information such as review of final construction documents which indicate conditions such as depth of excavation and/or site graded to bedrock, presence or absence of fossil resources, etc., which may reduce or increase the potential for resources to be present.
5. Approval of PME and Construction Schedule
After approval of the PME by MMC, the PI shall submit to MMC written authorization of the PME and Construction Schedule from the CM.

III. During Construction

- A. Monitor Shall be Present During Grading/Excavation/Trenching
 1. The monitor shall be present full-time during grading/excavation/trenching activities including, but not limited to mainline, laterals, jacking and receiving pits, services and all other appurtenances associated with underground utilities as identified on the PME that could result in impacts to formations with high and/or moderate resource sensitivity. **The Construction Manager is responsible for notifying the RE, PI, and MMC of changes to any construction activities such as in the case of a potential safety concern within the area being monitored. In certain circumstances OSHA safety requirements may necessitate modification of the PME.**
 2. The PI may submit a detailed letter to MMC during construction requesting a modification to the monitoring program when a field condition such as trenching activities that do not encounter formational soils as previously assumed, and/or when unique/unusual fossils are encountered, which may reduce or increase the potential for resources to be present.

3. The monitor shall document field activity via the Consultant Site Visit Record (CSVSR). The CSVSR's shall be faxed by the CM to the RE the first day of monitoring, the last day of monitoring, monthly (**Notification of Monitoring Completion**), and in the case of ANY discoveries. The RE shall forward copies to MMC.
- B. Discovery Notification Process
1. In the event of a discovery, the Paleontological Monitor shall direct the contractor to temporarily divert trenching activities in the area of discovery and immediately notify the RE or BI, as appropriate.
 2. The Monitor shall immediately notify the PI (unless Monitor is the PI) of the discovery.
 3. The PI shall immediately notify MMC by phone of the discovery, and shall also submit written documentation to MMC within 24 hours by fax or email with photos of the resource in context, if possible.
- C. Determination of Significance
1. The PI shall evaluate the significance of the resource.
 - a. The PI shall immediately notify MMC by phone to discuss significance determination and shall also submit a letter to MMC indicating whether additional mitigation is required. The determination of significance for fossil discoveries shall be at the discretion of the PI.
 - b. If the resource is significant, the PI shall submit a Paleontological Recovery Program (PRP) and obtain written approval of the program from MMC, MC and/or RE. PRP and any mitigation must be approved by MMC, RE and/or CM before ground disturbing activities in the area of discovery will be allowed to resume.
 - (1). Note: For pipeline trenching projects only, the PI shall implement the Discovery Process for Pipeline Trenching projects identified below under "D."
 - c. If resource is not significant (e.g., small pieces of broken common shell fragments or other scattered common fossils) the PI shall notify the RE, or BI as appropriate, that a non-significant discovery has been made. The Paleontologist shall continue to monitor the area without notification to MMC unless a significant resource is encountered.
 - d. The PI shall submit a letter to MMC indicating that fossil resources will be collected, curated, and documented in the Final Monitoring Report. The letter shall also indicate that no further work is required.
 - (1). Note: For Pipeline Trenching Projects Only. If the fossil discovery is limited in size, both in length and depth; the information value is limited and there are no unique fossil features associated with the discovery area, then the discovery should be considered not significant.
 - (2). Note, for Pipeline Trenching Projects Only: If significance cannot be determined, the Final Monitoring Report and Site Record shall identify the discovery as Potentially Significant.
- D. Discovery Process for Significant Resources - Pipeline Trenching Projects
- The following procedure constitutes adequate mitigation of a significant discovery encountered during pipeline trenching activities including but not limited to

excavation for jacking pits, receiving pits, laterals, and manholes to reduce impacts to below a level of significance.

1. Procedures for documentation, curation and reporting
 - a. One hundred percent of the fossil resources within the trench alignment and width shall be documented in-situ photographically, drawn in plan view (trench and profiles of side walls), recovered from the trench and photographed after cleaning, then analyzed and curated consistent with Society of Invertebrate Paleontology Standards. The remainder of the deposit within the limits of excavation (trench walls) shall be left intact and so documented.
 - b. The PI shall prepare a Draft Monitoring Report and submit to MMC via the RE as indicated in Section VI-A.
 - c. The PI shall be responsible for recording (on the appropriate forms for the San Diego Natural History Museum) the resource(s) encountered during the Paleontological Monitoring Program in accordance with the City's Paleontological Guidelines. The forms shall be submitted to the San Diego Natural History Museum and included in the Final Monitoring Report.
 - d. The Final Monitoring Report shall include a recommendation for monitoring of any future work in the vicinity of the resource.

IV. Night and/or Weekend Work

- A. If night and/or weekend work is included in the contract
 1. When night and/or weekend work is included in the contract package, the extent and timing shall be presented and discussed at the precon meeting.
 2. The following procedures shall be followed.
 - a. No Discoveries
In the event that no discoveries were encountered during night and/or weekend work, The PI shall record the information on the CSVN and submit to MMC via the RE via fax by 8AM on the next business day.
 - b. Discoveries
All discoveries shall be processed and documented using the existing procedures detailed in Sections III - During Construction.
 - c. Potentially Significant Discoveries
If the PI determines that a potentially significant discovery has been made, the procedures detailed under Section III - During Construction shall be followed.
 - d. The PI shall immediately contact the RE and MMC, or by 8AM on the next business day to report and discuss the findings as indicated in Section III-B, unless other specific arrangements have been made.
- B. If night and/or weekend work becomes necessary during the course of construction
 1. The Construction Manager shall notify the RE, or BI, as appropriate, a minimum of 24 hours before the work is to begin.
 2. The RE, or BI, as appropriate, shall notify MMC immediately.
- C. All other procedures described above shall apply, as appropriate.

V. Post Construction

A. Preparation and Submittal of Draft Monitoring Report

1. The PI shall submit two copies of the Draft Monitoring Report (even if negative), prepared in accordance with the Paleontological Guidelines which describes the results, analysis, and conclusions of all phases of the Paleontological Monitoring Program (with appropriate graphics) to MMC via the RE for review and approval within 90 days following the completion of monitoring,
 - a. For significant paleontological resources encountered during monitoring, the Paleontological Recovery Program or Pipeline Trenching Discovery Process shall be included in the Draft Monitoring Report.
 - b. Recording Sites with the San Diego Natural History Museum
The PI shall be responsible for recording (on the appropriate forms) any significant or potentially significant fossil resources encountered during the Paleontological Monitoring Program in accordance with the City's Paleontological Guidelines, and submittal of such forms to the San Diego Natural History Museum with the Final Monitoring Report.
2. MMC shall return the Draft Monitoring Report to the PI via the RE for revision or, for preparation of the Final Report.
3. The PI shall submit revised Draft Monitoring Report to MMC via the RE for approval.
4. MMC shall provide written verification to the PI of the approved report.
5. MMC shall notify the RE or BI, as appropriate, of receipt of all Draft Monitoring Report submittals and approvals.

B. Handling of Fossil Remains

1. The PI shall be responsible for ensuring that all fossil remains collected are cleaned and catalogued.

C. Curation of artifacts: Deed of Gift and Acceptance Verification

1. The PI shall be responsible for ensuring that all fossil remains associated with the monitoring for this project are permanently curated with an appropriate institution.
2. The PI shall submit the Deed of Gift and catalogue record(s) to the RE or BI, as appropriate for donor signature with a copy submitted to MMC.
3. The RE or BI, as appropriate shall obtain signature on the Deed of Gift and shall return to PI with copy submitted to MMC.
4. The PI shall include the Acceptance Verification from the curation institution in the Final Monitoring Report submitted to the RE or BI and MMC.

D. Final Monitoring Report(s)

1. The PI shall submit two copies of the Final Monitoring Report to MMC (even if negative), within 90 days after notification from MMC of the approved report.
2. The RE shall, in no case, issue the Notice of Completion until receiving a copy of the approved Final Monitoring Report from MMC which includes the Acceptance Verification from the curation institution.

The above mitigation monitoring and reporting program will require additional fees and/or deposits to be collected prior to the issuance of building permits, certificates of occupancy and/or final maps to ensure the successful completion of the monitoring program.

APPENDIX B
FIRE HYDRANT METER PROGRAM

CITY OF SAN DIEGO CALIFORNIA DEPARTMENT INSTRUCTIONS	NUMBER DI 55.27	DEPARTMENT Water Department
SUBJECT FIRE HYDRANT METER PROGRAM (FORMERLY: CONSTRUCTION METER PROGRAM)	PAGE 1 OF 10	EFFECTIVE DATE October 15, 2002
	SUPERSEDES DI 55.27	DATED April 21, 2000

1. **PURPOSE**

1.1 To establish a Departmental policy and procedure for issuance, proper usage and charges for fire hydrant meters.

2. **AUTHORITY**

2.1 All authorities and references shall be current versions and revisions.

2.2 San Diego Municipal Code (NC) Chapter VI, Article 7, Sections 67.14 and 67.15

2.3 Code of Federal Regulations, Safe Drinking Water Act of 1986

2.4 California Code of Regulations, Titles 17 and 22

2.5 California State Penal Code, Section 498B.0

2.6 State of California Water Code, Section 110, 500-6, and 520-23

2.7 Water Department Director

Reference

2.8 State of California Guidance Manual for Cross Connection Programs

2.9 American Water Works Association Manual M-14, Recommended Practice for Backflow Prevention

2.10 American Water Works Association Standards for Water Meters

2.11 U.S.C. Foundation for Cross Connection Control and Hydraulic Research Manual

3. **DEFINITIONS**

3.1 **Fire Hydrant Meter:** A portable water meter which is connected to a fire hydrant for the purpose of temporary use. (These meters are sometimes referred to as Construction Meters.)

CITY OF SAN DIEGO CALIFORNIA DEPARTMENT INSTRUCTIONS	NUMBER DI 55.27	DEPARTMENT Water Department
SUBJECT FIRE HYDRANT METER PROGRAM (FORMERLY: CONSTRUCTION METER PROGRAM)	PAGE 2 OF 10	EFFECTIVE DATE October 15, 2002
	SUPERSEDES DI 55.27	DATED April 21, 2000

- 3.2 **Temporary Water Use:** Water provided to the customer for no longer than twelve (12) months.
- 3.3 **Backflow Preventor:** A Reduced Pressure Principal Assembly connected to the outlet side of a Fire Hydrant Meter.

4. **POLICY**

- 4.1 The Water Department shall collect a deposit from every customer requiring a fire hydrant meter and appurtenances prior to providing the meter and appurtenances (see Section 7.1 regarding the Fees and Deposit Schedule). The deposit is refundable upon the termination of use and return of equipment and appurtenances in good working condition.
- 4.2 Fire hydrant meters will have a 2 ½" swivel connection between the meter and fire hydrant. The meter shall not be connected to the 4" port on the hydrant. All Fire Hydrant Meters issued shall have a Reduced Pressure Principle Assembly (RP) as part of the installation. Spanner wrenches are the only tool allowed to turn on water at the fire hydrant.
- 4.3 The use of private hydrant meters on City hydrants is prohibited, with exceptions as noted below. All private fire hydrant meters are to be phased out of the City of San Diego. All customers who wish to continue to use their own fire hydrant meters must adhere to the following conditions:
 - a. Meters shall meet all City specifications and American Water Works Association (AWWA) standards.
 - b. Customers currently using private fire hydrant meters in the City of San Diego water system will be allowed to continue using the meter under the following conditions:
 - 1. The customer must submit a current certificate of accuracy and calibration results for private meters and private backflows annually to the City of San Diego, Water Department, Meter Shop.

CITY OF SAN DIEGO CALIFORNIA DEPARTMENT INSTRUCTIONS	NUMBER DI 55.27	DEPARTMENT Water Department
SUBJECT FIRE HYDRANT METER PROGRAM (FORMERLY: CONSTRUCTION METER PROGRAM)	PAGE 3 OF 10	EFFECTIVE DATE October 15, 2002
	SUPERSEDES DI 55.27	DATED April 21, 2000

2. The meter must be properly identifiable with a clearly labeled serial number on the body of the fire hydrant meter. The serial number shall be plainly stamped on the register lid and the main casing. Serial numbers shall be visible from the top of the meter casing and the numbers shall be stamped on the top of the inlet casing flange.
3. All meters shall be locked to the fire hydrant by the Water Department, Meter Section (see Section 4.7).
4. All meters shall be read by the Water Department, Meter Section (see Section 4.7).
5. All meters shall be relocated by the Water Department, Meter Section (see Section 4.7).
6. These meters shall be tested on the anniversary of the original test date and proof of testing will be submitted to the Water Department, Meter Shop, on a yearly basis. If not tested, the meter will not be allowed for use in the City of San Diego.
7. All private fire hydrant meters shall have backflow devices attached when installed.
8. The customer must maintain and repair their own private meters and private backflows.
9. The customer must provide current test and calibration results to the Water Department, Meter Shop after any repairs.
10. When private meters are damaged beyond repair, these private meters will be replaced by City owned fire hydrant meters.

CITY OF SAN DIEGO CALIFORNIA DEPARTMENT INSTRUCTIONS	NUMBER DI 55.27	DEPARTMENT Water Department
SUBJECT FIRE HYDRANT METER PROGRAM (FORMERLY: CONSTRUCTION METER PROGRAM)	PAGE 4 OF 10	EFFECTIVE DATE October 15, 2002
	SUPERSEDES DI 55.27	DATED April 21, 2000

11. When a private meter malfunctions, the customer will be notified and the meter will be removed by the City and returned to the customer for repairs. Testing and calibration results shall be given to the City prior to any re-installation.
 12. The register shall be hermetically sealed straight reading and shall be readable from the inlet side. Registration shall be in hundred cubic feet.
 13. The outlet shall have a 2 ½ “National Standards Tested (NST) fire hydrant male coupling.
 14. Private fire hydrant meters shall not be transferable from one contracting company to another (i.e. if a company goes out of business or is bought out by another company).
- 4.4 All fire hydrant meters and appurtenances shall be installed, relocated and removed by the City of San Diego, Water Department. All City owned fire hydrant meters and appurtenances shall be maintained by the City of San Diego, Water Department, Meter Services.
- 4.5 If any fire hydrant meter is used in violation of this Department Instruction, the violation will be reported to the Code Compliance Section for investigation and appropriate action. Any customer using a fire hydrant meter in violation of the requirements set forth above is subject to fines or penalties pursuant to the Municipal Code, Section 67.15 and Section 67.37.
- 4.6 Conditions and Processes for Issuance of a Fire Hydrant Meter**
- Process for Issuance
- a. Fire hydrant meters shall only be used for the following purposes:
 1. Temporary irrigation purposes not to exceed one year.

CITY OF SAN DIEGO CALIFORNIA DEPARTMENT INSTRUCTIONS	NUMBER DI 55.27	DEPARTMENT Water Department
SUBJECT FIRE HYDRANT METER PROGRAM (FORMERLY: CONSTRUCTION METER PROGRAM)	PAGE 5 OF 10	EFFECTIVE DATE October 15, 2002
	SUPERSEDES DI 55.27	DATED April 21, 2000

2. Construction and maintenance related activities (see Tab 2).
 - b. No customer inside or outside the boundaries of the City of San Diego Water Department shall resell any portion of the water delivered through a fire hydrant by the City of San Diego Water Department.
 - c. The City of San Diego allows for the issuance of a temporary fire hydrant meter for a period not to exceed 12 months (365 days). An extension can only be granted in writing from the Water Department Director for up to 90 additional days. A written request for an extension by the consumer must be submitted at least 30 days prior to the 12 month period ending. No extension shall be granted to any customer with a delinquent account with the Water Department. No further extensions shall be granted.
 - d. Any customer requesting the issuance of a fire hydrant meter shall file an application with the Meter Section. The customer must complete a "Fire Hydrant Meter Application" (Tab 1) which includes the name of the company, the party responsible for payment, Social Security number and/or California ID, requested location of the meter (a detailed map signifying an exact location), local contact person, local phone number, a contractor's license (or a business license), description of specific water use, duration of use at the site and full name and address of the person responsible for payment.
 - e. At the time of the application the customer will pay their fees according to the schedule set forth in the Rate Book of Fees and Charges, located in the City Clerk's Office. All fees must be paid by check, money order or cashiers check, made payable to the City Treasurer. Cash will not be accepted.
 - f. No fire hydrant meters shall be furnished or relocated for any customer with a delinquent account with the Water Department.
 - g. After the fees have been paid and an account has been created, the

CITY OF SAN DIEGO CALIFORNIA DEPARTMENT INSTRUCTIONS	NUMBER DI 55.27	DEPARTMENT Water Department
SUBJECT FIRE HYDRANT METER PROGRAM (FORMERLY: CONSTRUCTION METER PROGRAM)	PAGE 6 OF 10	EFFECTIVE DATE October 15, 2002
	SUPERSEDES DI 55.27	DATED April 21, 2000

meter shall be installed within 48 hours (by the second business day). For an additional fee, at overtime rates, meters can be installed within 24 hours (within one business day).

4.7 Relocation of Existing Fire Hydrant Meters

- a. The customer shall call the Fire Hydrant Meter Hotline (herein referred to as “Hotline”), a minimum of 24 hours in advance, to request the relocation of a meter. A fee will be charged to the existing account, which must be current before a work order is generated for the meter’s relocation.
- b. The customer will supply in writing the address where the meter is to be relocated (map page, cross street, etc). The customer must update the original Fire Hydrant Meter Application with any changes as it applies to the new location.
- c. Fire hydrant meters shall be read on a monthly basis. While fire hydrant meters and backflow devices are in service, commodity, base fee and damage charges, if applicable, will be billed to the customer on a monthly basis. If the account becomes delinquent, the meter will be removed.

4.8 Disconnection of Fire Hydrant Meter

- a. After ten (10) months a “Notice of Discontinuation of Service” (Tab 3) will be issued to the site and the address of record to notify the customer of the date of discontinuance of service. An extension can only be granted in writing from the Water Department Director for up to 90 additional days (as stated in Section 4.6C) and a copy of the extension shall be forwarded to the Meter Shop Supervisor. If an extension has not been approved, the meter will be removed after twelve (12) months of use.
- b. Upon completion of the project the customer will notify the Meter Services office via the Hotline to request the removal of the fire hydrant meter and appurtenances. A work order will be generated

CITY OF SAN DIEGO CALIFORNIA DEPARTMENT INSTRUCTIONS	NUMBER DI 55.27	DEPARTMENT Water Department
SUBJECT FIRE HYDRANT METER PROGRAM (FORMERLY: CONSTRUCTION METER PROGRAM)	PAGE 7 OF 10	EFFECTIVE DATE October 15, 2002
	SUPERSEDES DI 55.27	DATED April 21, 2000

for removal of the meter.

- c. Meter Section staff will remove the meter and backflow prevention assembly and return it to the Meter Shop. Once returned to the Meter Shop the meter and backflow will be tested for accuracy and functionality.
- d. Meter Section Staff will contact and notify Customer Services of the final read and any charges resulting from damages to the meter and backflow or its appurtenance. These charges will be added on the customer's final bill and will be sent to the address of record. Any customer who has an outstanding balance will not receive additional meters.
- e. Outstanding balances due may be deducted from deposits and any balances refunded to the customer. Any outstanding balances will be turned over to the City Treasurer for collection. Outstanding balances may also be transferred to any other existing accounts.

5. **EXCEPTIONS**

- 5.1 Any request for exceptions to this policy shall be presented, in writing, to the Customer Support Deputy Director, or his/her designee for consideration.

6. **MOBILE METER**

- 6.1 Mobile meters will be allowed on a case by case basis. All mobile meters will be protected by an approved backflow assembly and the minimum requirement will be a Reduced Pressure Principal Assembly. The two types of Mobile Meters are vehicle mounted and floating meters. Each style of meters has separate guidelines that shall be followed for the customer to retain service and are described below:

- a) **Vehicle Mounted Meters:** Customer applies for and receives a City owned Fire Hydrant Meter from the Meter Shop. The customer mounts the meter on the vehicle and brings it to the Meter Shop for

CITY OF SAN DIEGO CALIFORNIA DEPARTMENT INSTRUCTIONS	NUMBER DI 55.27	DEPARTMENT Water Department
SUBJECT FIRE HYDRANT METER PROGRAM (FORMERLY: CONSTRUCTION METER PROGRAM)	PAGE 8 OF 10	EFFECTIVE DATE October 15, 2002
	SUPERSEDES DI 55.27	DATED April 21, 2000

inspection. After installation is approved by the Meter Shop the vehicle and meter shall be brought to the Meter Shop on a monthly basis for meter reading and on a quarterly basis for testing of the backflow assembly. Meters mounted at the owner's expense shall have the one year contract expiration waived and shall have meter or backflow changed if either fails.

b) **Floating Meters:** Floating Meters are meters that are not mounted to a vehicle. **(Note: All floating meters shall have an approved backflow assembly attached.)** The customer shall submit an application and a letter explaining the need for a floating meter to the Meter Shop. The Fire Hydrant Meter Administrator, after a thorough review of the needs of the customer, (i.e. number of jobsites per day, City contract work, lack of mounting area on work vehicle, etc.), may issue a floating meter. At the time of issue, it will be necessary for the customer to complete and sign the "Floating Fire Hydrant Meter Agreement" which states the following:

- 1) The meter will be brought to the Meter Shop at 2797 Caminito Chollas, San Diego on the third week of each month for the monthly read by Meter Shop personnel.
- 2) Every other month the meter will be read and the backflow will be tested. This date will be determined by the start date of the agreement.

If any of the conditions stated above are not met the Meter Shop has the right to cancel the contract for floating meter use and close the account associated with the meter. The Meter Shop will also exercise the right to refuse the issuance of another floating meter to the company in question.

Any Fire Hydrant Meter using reclaimed water shall not be allowed use again with any potable water supply. The customer shall incur the cost of replacing the meter and backflow device in this instance.

CITY OF SAN DIEGO CALIFORNIA DEPARTMENT INSTRUCTIONS	NUMBER DI 55.27	DEPARTMENT Water Department
SUBJECT FIRE HYDRANT METER PROGRAM (FORMERLY: CONSTRUCTION METER PROGRAM)	PAGE 9 OF 10	EFFECTIVE DATE October 15, 2002
	SUPERSEDES DI 55.27	DATED April 21, 2000

7. **FEE AND DEPOSIT SCHEDULES**

7.1 **Fees and Deposit Schedules:** The fees and deposits, as listed in the Rate Book of Fees and Charges, on file with the Office of the City Clerk, are based on actual reimbursement of costs of services performed, equipment and materials. These deposits and fees will be amended, as needed, based on actual costs. Deposits, will be refunded at the end of the use of the fire hydrant meter, upon return of equipment in good working condition and all outstanding balances on account are paid. Deposits can also be used to cover outstanding balances.

All fees for equipment, installation, testing, relocation and other costs related to this program are subject to change without prior notification. The Mayor and Council will be notified of any future changes.

8. **UNAUTHORIZED USE OF WATER FROM A HYDRANT**

8.1 Use of water from any fire hydrant without a properly issued and installed fire hydrant meter is theft of City property. Customers who use water for unauthorized purposes or without a City of San Diego issued meter will be prosecuted.

8.2 If any unauthorized connection, disconnection or relocation of a fire hydrant meter, or other connection device is made by anyone other than authorized Water Department personnel, the person making the connection will be prosecuted for a violation of San Diego Municipal Code, Section 67.15. In the case of a second offense, the customer's fire hydrant meter shall be confiscated and/or the deposit will be forfeited.

8.3 Unauthorized water use shall be billed to the responsible party. Water use charges shall be based on meter readings, or estimates when meter readings are not available.

8.4 In case of unauthorized water use, the customer shall be billed for all applicable charges as if proper authorization for the water use had been obtained, including but not limited to bi-monthly service charges, installation charges and removal charges.

CITY OF SAN DIEGO CALIFORNIA DEPARTMENT INSTRUCTIONS	NUMBER DI 55.27	DEPARTMENT Water Department
SUBJECT FIRE HYDRANT METER PROGRAM (FORMERLY: CONSTRUCTION METER PROGRAM)	PAGE 10 OF 10	EFFECTIVE DATE October 15, 2002
	SUPERSEDES DI 55.27	DATED April 21, 2000

- 8.5 If damage occurs to Water Department property (i.e. fire hydrant meter, backflow, various appurtenances), the cost of repairs or replacements will be charged to the customer of record (applicant).

Water Department Director

- Tabs: 1. Fire Hydrant Meter Application
2. Construction & Maintenance Related Activities With No Return To Sewer
3. Notice of Discontinuation of Service

APPENDIX

Administering Division: Customer Support Division

Subject Index: Construction Meters
Fire Hydrant
Fire Hydrant Meter Program
Meters, Floating or Vehicle Mounted
Mobile Meter
Program, Fire Hydrant Meter

Distribution: DI Manual Holders



Application for Fire Hydrant Meter (EXHIBIT A)

(For Office Use Only)

NS REQ	FAC#
DATE	BY

METER SHOP (619) 527-7449

Meter Information

Application Date	Requested Install Date:
------------------	-------------------------

Fire Hydrant Location: (Attach Detailed Map//Thomas Bros. Map Location or Construction drawing.) Zip:	T.B.	G.B. (CITY USE)
Specific Use of Water:		
Any Return to Sewer or Storm Drain, if so, explain:		
Estimated Duration of Meter Use:		Check Box if Reclaimed Water

Company Information

Company Name:			
Mailing Address:			
City:	State:	Zip:	Phone: ()
*Business license#		*Contractor license#	
A Copy of the Contractor's license OR Business License is required at the time of meter issuance.			
Name and Title of Billing Agent: <small>(PERSON IN ACCOUNTS PAYABLE)</small>			Phone: ()
Site Contact Name and Title:			Phone: ()
Responsible Party Name:			Title:
Cal ID#			Phone: ()
Signature:		Date:	
<small>Guarantees Payment of all Charges Resulting from the use of this Meter. Insures that employees of this Organization understand the proper use of Fire Hydrant Meter</small>			

Fire Hydrant Meter Removal Request	Requested Removal Date:
Provide Current Meter Location if Different from Above:	
Signature:	Title: Date:
Phone: ()	Pager: ()

<input type="checkbox"/> City Meter	<input type="checkbox"/> Private Meter	
Contract Acct #:	Deposit Amount: \$ 936.00	Fees Amount: \$ 62.00
Meter Serial #	Meter Size: 05	Meter Make and Style: 6-7
Backflow #	Backflow Size:	Backflow Make and Style:
Name:	Signature:	Date:

WATER USES WITHOUT ANTICIPATED CHARGES FOR RETURN TO SEWER

Auto Detailing
Backfilling
Combination Cleaners (Vactors)
Compaction
Concrete Cutters
Construction Trailers
Cross Connection Testing
Dust Control
Flushing Water Mains
Hydro Blasting
Hydro Seeing
Irrigation (for establishing irrigation only; not continuing irrigation)
Mixing Concrete
Mobile Car Washing
Special Events
Street Sweeping
Water Tanks
Water Trucks
Window Washing

Note:

1. If there is any return to sewer or storm drain, then sewer and/or storm drain fees will be charges.

Date

Name of Responsible Party
Company Name and Address
Account Number: _____

Subject: Discontinuation of Fire Hydrant Meter Service

Dear Water Department Customer:

The authorization for use of Fire Hydrant Meter # _____, located at *(Meter Location Address)* ends in 60 days and will be removed on or after *(Date Authorization Expires)*. Extension requests for an additional 90 days must be submitted in writing for consideration 30 days prior to the discontinuation date. If you require an extension, please contact the Water Department, or mail your request for an extension to:

City of San Diego
Water Department
Attention: Meter Services
2797 Caminito Chollas
San Diego, CA 92105-5097

Should you have any questions regarding this matter, please call the Fire Hydrant Hotline at (619) _____ - _____.

Sincerely,

Water Department

APPENDIX C

MATERIALS TYPICALLY ACCEPTED BY CERTIFICATE OF COMPLIANCE

Materials Typically Accepted by Certificate of Compliance

1. Soil amendment
2. Fiber mulch
3. PVC or PE pipe up to 16 inch diameter
4. Stabilizing emulsion
5. Lime
6. Preformed elastomeric joint seal
7. Plain and fabric reinforced elastomeric bearing pads
8. Steel reinforced elastomeric bearing pads
9. Waterstops (Special Condition)
10. Epoxy coated bar reinforcement
11. Plain and reinforcing steel
12. Structural steel
13. Structural timber and lumber
14. Treated timber and lumber
15. Lumber and timber
16. Aluminum pipe and aluminum pipe arch
17. Corrugated steel pipe and corrugated steel pipe arch
18. Structural metal plate pipe arches and pipe arches
19. Perforated steel pipe
20. Aluminum underdrain pipe
21. Aluminum or steel entrance tapers, pipe downdrains, reducers, coupling bands and slip joints
22. Metal target plates
23. Paint (traffic striping)
24. Conductors
25. Painting of electrical equipment
26. Electrical components
27. Engineering fabric
28. Portland Cement
29. PCC admixtures
30. Minor concrete, asphalt
31. Asphalt (oil)
32. Liquid asphalt emulsion
33. Epoxy

APPENDIX D
SAMPLE CITY INVOICE

City of San Diego, Field Engineering Div., 9485 Aero Drive, SD CA 92123						Contractor's Name:					
Project Name:						Contractor's Address:					
SAP No. (WBS/IO/CC)											
City Purchase Order No.						Contractor's Phone #:			Invoice No.		
Resident Engineer (RE):						Contractor's Fax #:			Invoice Date:		
RE Phone#:			RE Fax#:			Contact Name:			Billing Period:		
Item #	Item Description	Contract Authorization				Previous Estimate		This Estimate		Totals to Date	
		Unit	Qty	Price	Extension	%/QTY	Amount	% / QTY	Amount	% / QTY	Amount
1	2 Parallel 4" PVC C900	LF	1,380	\$34.00	\$46,920.00						
2	48" Primary Steel Casing	LF	500	\$1,000.00	\$500,000.00						
3	2 Parallel 12" Secondary Steel	LF	1,120	\$53.00	\$59,360.00						
4	Construction and Rehab of PS 49	LS	1	\$150,000.00	\$150,000.00						
5	Demo	LS	1	\$14,000.00	\$14,000.00						
6	Install 6' High Chain Link Fence	LS	1	\$5,600.00	\$5,600.00						
7	General Site Restoration	LS	1	\$3,700.00	\$3,700.00						
8	10" Gravity Sewer	LF	10	\$292.00	\$2,920.00						
9	4" Blow Off Valves	EA	2	\$9,800.00	\$19,600.00						
10	Bonds	LS	1	\$16,000.00	\$16,000.00						
11	Field Orders	AL	1	80,000	\$80,000.00						
11.1	Field Order 1	LS	5,500	\$1.00	\$5,500.00						
11.2	Field Order 2	LS	7,500	\$1.00	\$7,500.00						
11.3	Field Order 3	LS	10,000	\$1.00	\$10,000.00						
11.4	Field Order 4	LS	6,500	\$1.00	\$6,500.00						
12	Certified Payroll	LS	1	\$1,400.00	\$1,400.00						
CHANGE ORDERS											
Change Order 1			4,890								
Items 1-4					\$11,250.00						
Item 5-Deduct Bid Item 3		LF	120	-\$53.00	(\$6,360.00)						
Change Order 2			160,480								
Items 1-3					\$95,000.00						
Item 4 Deduct Bid Item 1		LF	380	-\$340.00	(\$12,920.00)						
Item 5-Encrease bid Item 9		LF	8	\$9,800.00	\$78,400.00						
Change Order 3 (Close Out)			-121,500								
Item 1 Deduct Bid Item 3			53	-500.00	(\$26,500.00)						
Item 2 Deduct Bid Item 4		LS	-1	45,000.00	(\$45,000.00)						
Items 3-9			1	-50,500.00	(\$50,500.00)						
SUMMARY								Total This	\$ -	Total Billed	\$0.00
A. Original Contract Amount						Retention and/or Escrow Payment Schedule					
B. Approved Change Order 1 Thru 3						Total Retention Required as of this billing					
C. Total Authorized Amount (A+B)						Previous Retention Withheld in PO or in Escrow					
D. Total Billed to Date						Add'l Amt to Withhold in PO/Transfer in Escrow:					
E. Less Total Retention (5% of D)						Amt to Release to Contractor from PO/Escrow:					
F. Less Total Previous Payments											
G. Payment Due Less Retention						Contractor Signature and Date:					
H. Remaining Authorized Amount											

APPENDIX E
LOCATION MAP

SEWER MAIN REPLACEMENT GROUP 691

SENIOR ENGINEER
RANIA AMEN
@ 619-533-5492

PROJECT MANAGER
JERICHO GALLARDO
@ 619-533-7523

PROJECT ENGINEER
JOEY GUIINTO
@ 619-533-5474

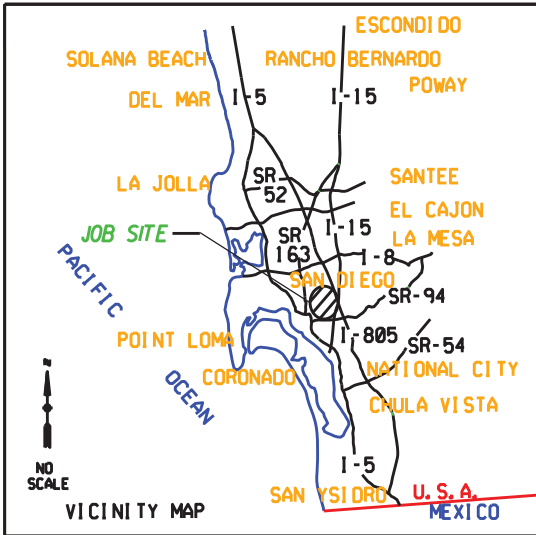

BALBOA PARK
GOLF COURSE

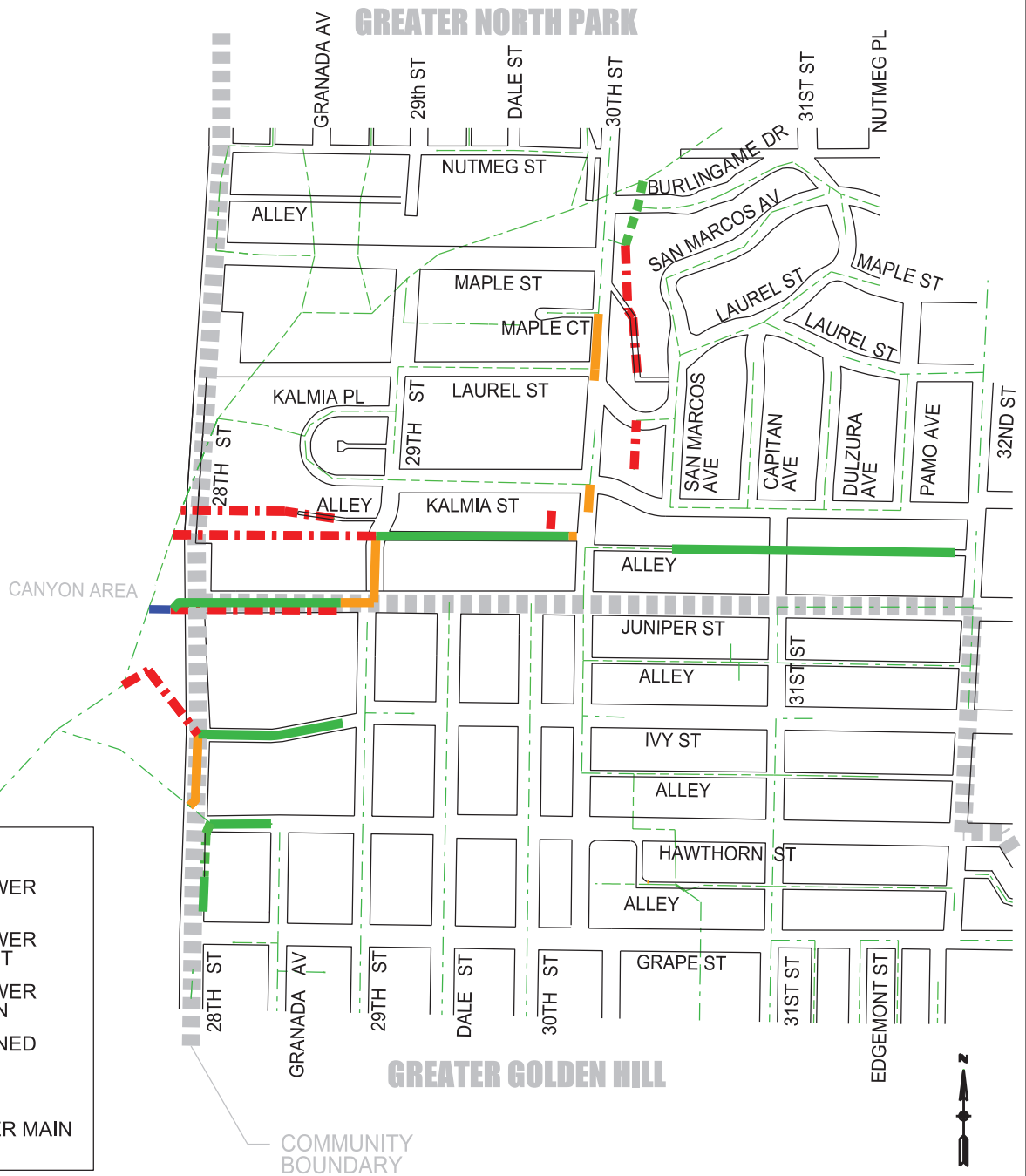

LEGEND:

- PROPOSED SEWER REPLACEMENT
- PROPOSED SEWER NEW ALIGNMENT
- - - PROPOSED SEWER REHABILITATION
- - - TO BE ABANDONED
- PROPOSED PIPEBURSTING
- - - EXISTING SEWER MAIN

APPENDIX F

LONG-TERM REVEGETATION MAINTENANCE AGREEMENT

LONG-TERM REVEGETATION MAINTENANCE CONTRACT

This Long-Term Revegetation Maintenance Contract [Contract] is made and entered into by and between the City of San Diego [City], a municipal corporation, and Ortiz Corporation [Contractor], who may be individually or collectively referred to herein as a "Party" or the "Parties."

RECITALS

- A. Concurrent with the Contract execution, the Parties entered into an agreement [Agreement] for the construction of **Sewer Group 691**, WBS# **B-00446**, Bid No. **K-15-5875-DBB-3-C**.
- B. In accordance with the Agreement, the Contractor shall enter into this contract with the City for the purpose of implementing and fulfilling long-term revegetation maintenance and monitoring requirements in accordance with the City of San Diego Municipal Code and the Contract Documents for the specified elopement(s) of **Sewer Group 691** [Maintenance Requirements].
- C. The Contractor is ready and willing to fulfill its maintenance requirements in accordance with the terms of this contract i.e., Maintenance Requirements.

NOW, THEREFORE, in consideration of the above recitals and the mutual covenants and conditions set forth herein, and for good and valuable consideration, the receipt and sufficiency of which are hereby acknowledged, the Parties hereby set forth their mutual covenants and understandings as follows:

INTRODUCTORY PROVISIONS

- A. **Recitals Incorporated.** The above referenced Recitals are true and correct and are incorporated into this contract by this reference.
- B. **Exhibits Incorporated.** All Exhibits and Attachments referenced in this contract are incorporated into this contract by this reference.
- C. **Contract Term.** This contract shall be effective on the date the Notice of Completion for the Agreement is executed, and it shall be effective until completion of the Work, described in Section 1.1 below.
- D. **Terms and Conditions.** This contract is subject to the terms and conditions of the Agreement included in The GREENBOOK and The WHITEBOOK i.e., Part 1, Sections 212, 308, and 700 through Section 708 and The WHITEBOOK EOCP Section except as follows.

SECTION 1: SCOPE OF WORK

- 1.1 **General.** The Contractor shall fulfill the Project's Maintenance Requirements [Work] as identified in the scope of work attached as Exhibit A in a manner satisfactory to the City.

The Contractor shall provide all equipment, labor, and materials necessary to perform the **Work** as described in the written in Exhibit A, at the direction of the City.

- 1.2 Work Schedule.** After receiving notification from the City, the Contractor shall create a comprehensive schedule of Work for performance of this contract [Schedule] for the City's approval. The Schedule shall include routine work and inspection and infrequent operations such as repairs, fertilization, aerification, watering, and pruning.

The City will approve the Schedule prior to the commencement of the Work. The City may require the Contractor to revise the Schedule. The Contractor shall not revise the Schedule unless the revisions have received the prior written approval of the City.

- 1.3 Commencement of Work & Maintenance Period.** The Contract shall begin on the date indicated in the field notification to be issued by City to the Contractor in accordance with the Project's Agreement [Field Notification], and shall continue for *twenty five (25)* months. A copy of the Field Notification shall be attached hereto as Exhibit B.

- 1.4 Performance of Work.** The Work shall be performed in accordance with the manufacturer's recommendations.

- 1.5 License.** The Contractor shall hold the following licenses in good standing:

- a) C-27 State Contractor's License. Alternatively, the Contractor shall retain the services of a Subcontractor with a C-27 State Contractor's License.
- b) Pest Control Advisor's License. Alternatively, the Contractor shall retain the services of a licensed Pest Control Advisor.
- c) Registration with the County Agriculture Commission.
- d) Qualified Applicator's Certificate for Category B. This shall apply to any person supervising the use of pesticides, herbicides, or rodenticides.
- e) City of San Diego Business License.

Prior to performing the Work, the Contractor shall complete and submit to the City the License Data Sheet. See Exhibit C.

- 1.6 Hours of Performance.** The Contractor shall perform the Work between the hours of 6:00 a.m. and 6:00 p.m., Monday through Friday [Working Hours]. The City may, in its sole discretion, grant permission to Contractor to perform Work during non-Working Hours. Maintenance functions that generate excess noise, e.g., operations of power equipment which would cause annoyance to area residents, shall not begin before 7:00 a.m.

SECTION 2: ADMINISTRATION

- 2.1 Contract Administrator.** The Public Works Department-E&CP/Right-Of-Way Division is the Contract Administrator for the Contract. The Contractor shall perform the Work under the direction of a designated representative of the Public Works Department. The City will communicate with the Contractor on all matters related to the administration of this contract and the Contractor's performance of the Work rendered hereunder. When this contract refers to communications to or with City, those communications shall be with the City, unless the City or this contract specifies otherwise. Further, when this contract requires an act or approval by City, that act or approval will be performed by the City.

- 2.2 **Local Office.** The Contractor shall maintain a local office with a competent company representative who can be reached during Normal Working Hours and who is authorized to discuss matters pertaining to this contract with the City. A local office is one located in San Diego County that can be reached by telephone and facsimile. An answering service in conjunction with a company email address for the designated company representative would fulfill this requirement. A mobile telephone shall not fulfill the requirement for a local office. All calls from the City shall be returned within a 1 hour period.
- 2.3 **Emergency Calls.** The Contractor shall have the capability to receive and to respond immediately to calls of an emergency nature. The City shall refer emergency calls to Contractor for immediate disposition. The Contractor shall provide City with a 24 hour emergency telephone number for this purpose.
- 2.4 **Staffing.** The Contractor shall furnish sufficient supervisory and working personnel capable of promptly accomplishing on schedule, and to the satisfaction of City, all Work required under this contract.
- 2.5 **Contractor Inspections.** The Contractor shall perform inspections of the Work site and prepare and submit to the City a Punchlist and dates of correction. The Punchlist shall include a comprehensive report of Work performed at the Work site to ensure 100% cover.

PART 3: WORK SITE MAINTENANCE

- 3.1 **Use of Chemicals.** The Contractor shall submit to City for approval sample labels and MSDS for all chemical herbicides, rodenticides and pesticides proposed for use under this contract. Materials included shall be limited to chemicals approved by the State of California Department of Agriculture.

The use of any chemical shall be based on the recommendations of a licensed pest control advisor. Annual PCA Pesticide Recommendations are required for each pesticide proposed to be used for the Work site covered by this contract. The use of chemicals shall conform to the current San Diego County Department of Agriculture regulations.

No chemical herbicide, rodenticide, or pesticide shall be applied until its use is approved, in writing, by City as appropriate for the purpose and area proposed.

The Contractor shall submit a monthly pesticide use report to City along with Contractor's invoices for payment. This report shall include a statement of all applications of herbicides, rodenticides, and pesticides, detailing the chemical used, undiluted quantity, rate of application, applicator's name, and the date and purpose of the application. For months in which no pesticides are applied, state "No Pesticide Used" on the report.

- 3.2 **Irrigation Water.** The Contractor shall diligently practice water conservation, including minimizing run-off or other waste. The Contractor shall turn off irrigation systems, if any, during periods of rainfall and at such other times when suspension of irrigation is desirable to conserve water and to remain within the guidelines of good horticulturally acceptable landscape maintenance practices. The Contractor's failure to properly manage and conserve water may result in deductions or other penalties.

If Contractor causes excessive use or waste of irrigation water, the estimated cost of that water shall be deducted from the monthly payment. Further, any monetary fines or other

damages assessed to City for Contractor's failure to follow water conservation regulations imposed by the City, the State of California, the County Water Authority, or other legal entity shall be Contractor's responsibility and may be deducted from the monthly payment.

- 3.3 Payment for Water.** The Contractor shall pay for the water used in the maintenance of the Work site unless specified otherwise.
- 3.4 Satisfactory Progression.** If the Revegetation Area is not progressing towards the required 100% Cover, as defined in the Scope of Work, in accordance with the Work Schedule, as determined by City, City may adjust monthly payments to Contractor accordingly.

SECTION 4: COMPENSATION

- 4.1 Maximum Compensation.** The compensation for this contract shall not exceed **\$58,777.92** [Contract Price].
- 4.2 Wage Rates.** Refer to the Agreement for Prevailing wages requirements for this contract.
- 4.3 Method of Payment and Reports.** The payments will be made monthly as a linear percentage of the Contract Price. As conditions precedent to payment, the Contractor shall submit every month a detailed invoice and report of maintenance work performed. The Contractor's failure to submit the required reports or certified payrolls as described in the Agreement shall constitute a basis for withholding of payment by the City.
- 4.4 Final Payment.** The Contractor shall not receive the final payment until the following conditions have been completed to the City's satisfaction:

The item(s) of the work subject to this maintenance coverage as specified in Exhibit A [Maintenance Items] have been determined to be in compliance with the Agreement and this contract.

The Contractor has provided to the City a signed and notarized Affidavit of Disposal, a copy of which is attached to the Agreement, stating that all brush, trash, debris, and surplus materials resulting from the Work have been disposed of in a legal manner.

The Contractor has performed comprehensive and successful testing and checks of the Maintenance Items.

- 4.5** Notwithstanding sections 3.3 and 3.4, the Contractor may request that the City pay all or some of the compensation for the Contract at a time earlier than provided in those sections if the Contractor provides a surety bond acceptable to the City which secures performance of the Contract for the full remaining term. Early payment under this section and acceptability of such bond shall be at the City's sole discretion.

SECTION 5: BONDS AND INSURANCE

- 5.1 Contract Bonds.** Prior to commencement of the Work, Contractor, at its sole cost and expense, shall provide to City the following bonds issued by a surety authorized to issue bonds in California and otherwise satisfactory to City:

A Payment Bond (Material and Labor Bond) in an amount not less than the Contract Price, to satisfy claims of material suppliers and mechanics and laborers employed by it on the Work. The Payment Bond shall be maintained by the Contractor in full force and effect until the Work is accepted by City and until all claims for materials and labor are paid, and shall otherwise comply with the California Civil Code.

A Performance Bond in an amount not less than the Contract Price to guarantee faithful performance of all Work, within the time prescribed, in a manner satisfactory to the City, and that all materials and workmanship will be free from original or developed defects. The Performance Bond shall remain in full force and effect until performance of the Work is completed as set forth in this contract.

5.2 Insurance. At all times during the term of this contract, the Contractor shall maintain insurance coverage as specified in the Agreement, Section 7-3, "LIABILITY INSURANCE."

The Contractor shall not begin the Work under this contract until it has complied with the following:

- a) Obtain insurance certificates reflecting evidence of insurance as specified in the Agreement, Section 7-3, "LIABILITY INSURANCE" for:
 1. Commercial General Liability
 2. Commercial Automobile Liability
 3. Worker's Compensation

The Contractor shall submit copies of any policy upon request by the City.

- b) Confirm that all policies contain the specific provisions required in Section 7-3, "LIABILITY INSURANCE."

The Contractor shall not modify any policy or endorsement thereto which increases the City's exposure to loss for the duration of this contract.

SECTION 6: MISCELLANEOUS

6.1 Illness and Injury Prevention Program. The Contractor shall comply with all the mandates of Senate Bill 198 and specifically shall have a written Injury Prevention Program on file with the City in accordance with all applicable standards, orders, or requirements of California Labor Code, Section 6401.7. This Program shall be on file prior to performance of any Work.

6.2 City Standard Provisions. This contract is subject to the following standard provisions. See The WHITEBOOK for details.

1. The City of San Diego Resolution No. R-277952 adopted on May 20, 1991 for a Drug-Free Workplace.
2. The City of San Diego Resolution No. R-282153 adopted on June 14, 1993 related to the Americans with Disabilities Act.

3. The City of San Diego Municipal Code §22.3224 as amended 11/24/08 by ordinance O-19808 for Pledge of Compliance.
4. The City of San Diego's Labor Compliance Program and the State of California Labor Code §§1771.5(b) and 1776 (Stats. 1978, Ch. 1249).
5. Sections 1777.5, 1777.6, and 1777.7 of the State of California Labor Code concerning the employment of apprentices by contractors and subcontractors performing public works contracts.
6. The City's Equal Benefits Ordinance (EBO), Chapter 2, Article 2, Division 43 of The San Diego Municipal Code (SDMC).
7. The City's Information Security Policy (ISP) as defined in the City's Administrative Regulation 90.63.

- 6.3 Taxpayer Identification Number.** I.R.S. regulations require the City to have the correct name, address, and Taxpayer Identification Number (TIN) or Social Security Number (SSN) on file for businesses or persons who provide services or products to the City. This information is necessary to complete Form 1099 at the end of each tax year. As such, the Contractor shall provide the City with a Form W-9 upon execution of this contract.
- 6.4 Assignment.** The Contractor shall not assign the obligations under this contract, whether by express assignment or by sale of the company, nor any monies due or to become due, without City's prior written approval. Any assignment in violation of this Section shall constitute a Default and is grounds for immediate termination of this contract, at the sole discretion of City. In no event shall any putative assignment create a contractual relationship between City and any putative assignee.
- 6.5 Independent Contractors.** The Contractor and any Subcontractors employed by Contractor shall be independent contractors and not agents of City. Any provisions of this contract that may appear to give City any right to direct Contractor concerning the details of performing the Work, or to exercise any control over such performance, shall mean only that Contractor shall follow the direction of City concerning the end results of the performance.
- 6.6 Covenants and Conditions.** All provisions of this contract expressed as either covenants or conditions on the part of the City or the Contractor shall be deemed to be both covenants and conditions.
- 6.7 Jurisdiction, Venue, and Attorney's Fees.** The venue for any suit or proceeding concerning this contract, the interpretation or application of any of its terms, or any related disputes shall be in the County of San Diego, State of California. The prevailing Party in any such suit or proceeding shall be entitled to a reasonable award of attorney's fees in addition to any other award made in such suit or proceeding.
- 6.8 Successors in Interest.** This Contract and all rights and obligations created by this contract shall be in force and effect whether or not any Parties to the Contract have been succeeded by another entity, and all rights and obligations created by this contract shall be vested and binding on any Party's successor in interest.

- 6.9 Integration.** This Contract and the exhibits, attachments, and references incorporated into this contract fully express all understandings of the Parties concerning the matters covered in this contract. No change, alteration, or modification of the terms or conditions of this contract, and no verbal understanding of the Parties, their officers, agents, or employees shall be valid unless made in the form of a written change agreed to in writing by both Parties or an amendment to this contract agreed to by both Parties. All prior negotiations and agreements are merged into this contract.
- 6.10 Counterparts.** This Contract may be executed in counterparts, which when taken together shall constitute a single signed original as though all Parties had executed the same page.
- 6.11 No Waiver.** No failure of either the City or the Contractor to insist upon the strict performance by the other of any covenant, term or condition of this contract, nor any failure to exercise any right or remedy consequent upon a breach of any covenant, term, or condition of this contract, shall constitute a waiver of any such breach or of such covenant, term or condition. No waiver of any breach shall affect or alter this contract, and each and every covenant, condition, and term hereof shall continue in full force and effect to any existing or subsequent breach.
- 6.12 Severability.** The unenforceability, invalidity, or illegality of any provision of this contract shall not render any other provision of this contract unenforceable, invalid, or illegal.
- 6.13 Drafting Ambiguities.** The Parties agree that they are aware that they have the right to be advised by counsel with respect to the negotiations, terms and conditions of this contract, and the decision of whether to seek advice of counsel with respect to this contract is a decision which is the sole responsibility of each Party. This Contract shall not be construed in favor of or against either Party by reason of the extent to which each Party participated in the drafting of the Contract.
- 6.14 Signing Authority.** The representative for each Party signing on behalf of a corporation, partnership, joint venture or governmental entity hereby declares that authority has been obtained to sign on behalf of the corporation, partnership, joint venture, or entity and agrees to hold the other Party or Parties hereto harmless if it is later determined that such authority does not exist.

IN WITNESS WHEREOF, this Contract is executed by the City of San Diego, acting by and through its Public Works Department Director, and by Contractor.

Dated this 6TH day of APRIL, 2017.

THE CITY OF SAN DIEGO

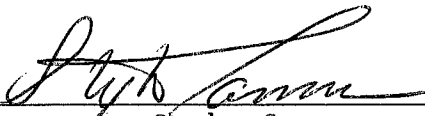
By: 
Stephen Samara
Principal Contract Specialist
Public Works Department

I HEREBY CERTIFY I can legally bind **Ortiz Corporation** and that I have read this entire contract, this 3rd day of April, 2017.

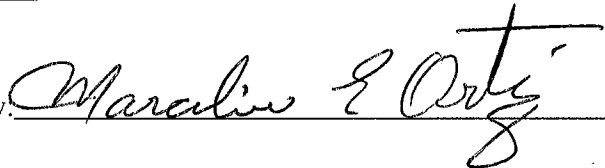
By: 

Printed Name: Marcelino E. Ortiz

Title: President

I HEREBY APPROVE the form and legality of the foregoing Contract this 18th day of April, 2017.

Mara W. Elliot, City Attorney

By: 

Printed Name: Pedro De Lara, Jr.

Deputy City Attorney

EXHIBIT A

SCOPE OF WORK

- I. Location of Work.** The location of the Work to be performed [Revegetation Area] is shown on those Specifications and Drawings numbered 32506-01-D through 32506-22-D [Specifications], which are incorporated into this contract by this reference as though fully set forth herein.
- II. Description of Work.** The Contractor shall maintain and monitor the Revegetation Area during the Monitoring Program in accordance with this contract and the Specifications such that the Revegetation Area meets the success criteria specified in the Revegetation Plan at each of the milestones listed and on the last date of the Monitoring Program as set forth in the Work Schedule. The Work includes complete landscape maintenance consisting of irrigation, pruning, shaping and training of trees, shrubs, and ground cover plants; fertilization; weed control; control of all plant diseases and pests; and trash removal, and all other maintenance listed in this contract and as required to maintain the Revegetation Area in a safe, attractive and useable condition and to maintain the plant material in good ecologically healthy and viable condition.

The work also includes biological monitoring of the Revegetation Area according to the schedule and methods specified in the Revegetation Plan. The monitoring work shall include all reporting tasks specified in the Revegetation plan.

III. Method of Performing Work.

- A. Irrigation. Irrigation shall be applied to container and salvaged plants at the discretion of the Project Biologist. Delivery techniques and schedules will vary depending on the availability of a sprinkler irrigation system and weather patterns. Timing of implementation is intended to use natural precipitation, but supplemental watering shall be applied when needed. Failure of an existing irrigation system to provide full and proper coverage shall not relieve Contractor of the responsibility to provide adequate irrigation with full and proper coverage to all areas.
1. In areas where an automatic sprinkler system is installed, Contractor shall periodically inspect the operation of the system for any malfunction. The maximum interval between inspections shall not exceed 7 days. The Contractor shall maintain all sprinkler systems in such a way as to guarantee proper coverage and full working capability, and shall make whatever adjustments may be necessary to prevent excessive run-off into streets, rights-of-way, or other areas not meant to be irrigated. The cost of wasted water may be charged to Contractor.
 2. All areas not adequately covered by a sprinkler system shall be irrigated by a portable irrigation method. The Contractor shall furnish all hoses, nozzles, sprinklers, etc. necessary to accomplish this supplementary irrigation. Care shall be exercised to prevent water waste, erosion, and/or detrimental seepage into existing underground improvements or structures.
 3. Irrigation shall be accomplished as follows:

- a) Turf (if any) shall be irrigated Monday through Friday, as required, to maintain horticulturally acceptable growth and color, and to encourage deep rooting. Daily watering should be avoided wherever possible, in favor of scheduling applications every other night or twice each week. Additional irrigations shall be performed in the event of unusually hot/dry weather conditions (as are present during Santa Ana conditions, or other times of low humidity or high winds, or during a prolonged high temperature period during summer months).
 - b) Landscaped improved banks and slopes (if any) shall be irrigated Monday through Friday as required to maintain horticulturally acceptable growth and color, and to encourage deep rooting.
 - c) Shrub beds (if any) shall be irrigated as required to maintain horticulturally acceptable growth and color, and to promote deep rooting. Shrub areas shall be irrigated at a rate which keeps surface runoff to a minimum. The irrigation rate shall be adjusted to the needs of shrub types, seasons and weather conditions.
 - d) Planted and seeded areas shall be irrigated as required to maintain ecologically acceptable growth, form and health, and to promote deep rooting. Planted and seeded areas shall be irrigated at a rate which keeps surface runoff to a minimum. The irrigation rate shall be adjusted to the needs of plant types, seasons and weather conditions.
4. Maintenance of Irrigation System. The Contractor shall keep controller and valve boxes (if any) clear of soil and debris and shall maintain the irrigation system at no additional cost to City, including replacement, repair, adjustment, raising or lowering, straightening and any other operation required for the continued proper operation of the system from the "cold" side of the water meter throughout the Revegetation Area. The Contractor shall also be responsible for maintaining the painted surfaces of irrigation and lighting controller cabinets as well as the corresponding automatic irrigation battery numbers on the lids of the automatic control valve boxes (if any). The Contractor shall be responsible for light bulb replacements in controller cabinets as necessary.
- a) Repair or replacement includes: sprinkler system laterals (piping), sprinkler mains (pressure lines), vacuum breakers, sprinkler control valves, sprinkler controllers, sprinkler heads, sprinkler caps, sprinkler head risers, valve covers, boxes and lids (including electrical pull boxes and lids), valve sleeves and lids, quick coupler valves and hose bibs. Any replacement shall conform to the type and kind of existing system. Any deviation shall be approved in writing by City.
 - b) Contractor shall repair irrigation systems which are damaged or altered in any way, including by acts of God, vandalism, vehicular damage, or theft.
5. Operation of Automatic Irrigation Controllers. Where the operation of automatic irrigation controllers is required as part of this contract, Contractor shall:
- i) Not duplicate any coded City key furnished by City for access and operation of the controller;

- ii) surrender all keys furnished by City, promptly at the end of the Contract term, or at any time deemed necessary by City to prevent serious loss to City;
- iii) protect the security of City's property by keeping controller cabinet and building doors locked at all times; and
- iv) refrain from using premises behind locked doors for storage of materials, supplies, or tools except as approved by City.

B. Pruning Shrubs and Ground Cover Plants. The Contractor shall prune all shrubs and ground cover plants growing in the Revegetation Area as required to:

- i) maintain plants in a healthy, growing condition;
- ii) maintain plant growth within reasonable bounds;
- iii) prevent encroachment of passage ways, walks, streets, or view of signs; and
- iv) prevent encroachment in any manner deemed objectionable by City.

The Contractor shall remove dead or damaged limbs with sharp pruning tools, with no stubs remaining. The Contractor shall seal any pruning cut which exceeds 2" in diameter with an approved pruning paint when required by City. The Contractor shall perform pruning to permit plants to grow naturally in accordance with their normal growth characteristics except where box hedging is required by City. The Contractor shall not shear, hedge, or severely prune plants, unless authorized by City. The Contractor shall not use growth regulators.

C. Tree Maintenance. Contractor shall maintain all trees in the revegetation area in their natural shapes. The Contractor shall perform pruning to promote the best growth habits, appearance, and health of the tree, and to prevent encroachment which blocks vision or is in any manner deemed undesirable by City. The Contractor is responsible for tree pruning that can be accomplished with a 12' pole saw by a worker standing on the ground. The Contractor shall not top trees.

1. Potential Hazards. The Contractor shall notify City within 24 hours of any tree that shows signs of root heaving or leaning, or is in any manner a potential safety hazard. The Contractor shall immediately reestablish trees and shrubs that are uprooted due to storms, if possible. If trees or shrubs cannot be reestablished, Contractor shall remove them immediately (including roots) and fill the holes until replacement planting is complete.
2. Replacement. The Contractor shall completely remove and replace trees lost due to Contractor's faulty maintenance or negligence, as determined by City. The Contractor shall replace trees in kind and size as determined by City. If there is a difference in value between the tree lost and the replacement tree, City will deduct the difference from the Contract payment. The City shall determine the value of the tree lost using the latest International Society of Arboriculture (I.S.A.) guidelines for value determination.

3. Staking. The Contractor shall securely stake any newly planted trees and other trees needing support with 2 “lodge pole” type stakes placed on opposite sides of the tree outside the root ball and secured to the tree with at least two flexible rubber tree ties. The Contractor shall regularly inspect tree ties and stakes and reposition them as necessary to ensure against girdling and abrasion.
- D. Fertilization. Contractor shall fertilize the Revegetation Area as necessary to meet the success criteria specified in the Revegetation Plan at each of the milestones listed and on the last date of the Monitoring Program as set forth in the Work Schedule Prior to any fertilization, Contractor shall submit to City Material Safety Data Sheets and a schedule of application showing the site, date, and approximate time of fertilizer application [Fertilizer Schedule]. The Fertilization Schedule, regardless of its intensity, timing, or the number of sites covered daily or weekly, shall not excuse Contractor from performing any other Work regularly required under this contract. All fertilization shall first be approved by the Project Biologist.
1. Contractor shall notify City at least 48 hours before beginning any fertilization. Fertilizer shall be delivered to the site only in the original unopened containers bearing the manufacturer’s guaranteed analysis. Damaged packages shall not be accepted. The Contractor shall furnish City with duplicate signed, legible copies of all certificates and invoices for all fertilizer to be used for this contract. The invoices shall state the grade, amount and quantity received. Both the copy to be retained by City and Contractor’s copy shall be signed by City, on site, before any fertilizer may be used.
 2. Fertilizers, if necessary, shall be applied at the direction of the Project Biologist and according to manufacturer’s product specifications.
 3. If deemed necessary by City to achieve required results, Contractor shall apply other materials as directed by City, including:
 - i) iron chelate;
 - ii) soil sulfur;
 - iii) gypsum; or
 - iv) surfactant enzymes such as Sarvon or Naiad.
 4. Contractor shall adequately irrigate the fertilized area(s) immediately following the application of fertilizers and/or amendments to force fertilizer material to rest directly on the soil surface. Drip irrigated areas shall be adequately hand watered using quick coupler valves and hoses to dissolve fertilizer.
- E. Weed Removal. Contractor shall completely remove weeds from the Revegetation Area, including all turf grass areas, shrub and ground cover areas, planters, tree wells, and cracks in paved areas, including sidewalks, parking lot, gutters and curbs, as shown on the Work Schedule. For the purposes of this Section, “Weed” means any undesirable or misplaced plant. The Contractor shall control Weeds by manual, mechanical, or chemical methods. The City or Project Biologist may restrict the use of chemical weed control in certain areas.

- F. Disease and Pest Control. The Contractor shall regularly inspect the Revegetation Area for the presence of disease and insect or rodent infestation. The Contractor shall notify City within 4 days if disease or insect or rodent infestation is discovered. In its notice to City, Contractor shall identify the disease, insect, or rodent and specify the control measures to be taken. Upon approval of City, Contractor shall implement the approved control measures, exercising extreme caution in the application of all sprays, dusts, or other materials utilized. The Contractor shall continue the approved control measures until the disease, insect, or rodent is controlled to the satisfaction of City.
1. All individuals who supervise the mixing and application of herbicides, pesticides, and rodenticides on behalf of Contractor shall possess valid Qualified Applicators Certificate for Category B issued to them by the State Department of Food and Agriculture.
 2. Contractor shall utilize all safeguards necessary during disease, insect or rodent control operations to ensure safety of the public and the employees of Contractor, in accordance with current standard practices accepted by the State of California Department of Food and Agriculture. If Contractor is unable to control the pest or disease, a pest control company will be hired and the cost shall be deducted from Contractor's monthly payment.
- G. Plant Replacement. Except as provided in Section H below, Contractor shall notify City within 4 days of the loss of plant material due to any cause.
1. Contractor shall at no cost to City replace any tree, shrub, ground cover, or other plant which is damaged or lost as a result of Contractor's faulty maintenance or negligence. The size and species of replacement plant materials shall be as directed by City.
 2. If so directed by City, Contractor shall replace any plant damaged or lost that is not a result of Contractor's faulty maintenance or negligence. The size and species of replacement plant materials shall be as directed by City. The City will pay for materials and labor.
 3. City may determine that certain plants should be replaced in order to ensure maximum ecological health and overall aesthetic appearance of planting in the Revegetation Area. When City determines such replacement should occur, Contractor shall replace the plants as directed by City. City will pay for materials and labor.
- H. Damage Reports. The Contractor shall notify City within 24 hours of any damage to the Work Area caused by accident, vandalism or theft.
- I. Litter. The Contractor shall promptly dispose of all trash and debris at an appropriate City disposal site. The Contractor shall pay any and all fees associated with the disposal of debris or trash accumulated under the terms of this contract. The Contractor understands that disposal of refuse at City landfills is subject to a fee and that the Refuse Disposal Division can be contacted at (619) 573-1418 for fee information.

1. Contractor Generated Litter. The Contractor shall promptly remove all debris generated by Contractor's pruning, trimming, weeding, edging and other Work required by this contract. Immediately after working in streets, park walks, gutters, driveways, and paved areas, Contractor shall clean them in accordance with all applicable laws.
2. Third Party Generated Litter. Upon discovery Contractor shall remove all litter, including bottles, glass, cans, paper, cardboard, fecal matter, leaves, branches, metallic items, and other debris, from the Work site.

EXHIBIT B
FIELD NOTIFICATION

EXHIBIT C
LICENSE DATA SHEET

State Contractor License Classification and Number: **C27 - #440492**

Name of License Holder: **D&D WILDLIFE HABITAT RESTORATION, INC.**

Expiration Date: **05/31/2018**

Pest Control Applicator's Name: **Robert L. Mazalewski, Jesus A. Reyes**

License Number: **QAL - #98951, QAL - #132856**

Expiration Date: **12/31/2017, 12/31/2017**

Pest Control Advisor's Name: **Robert L. Mazalewski**

License Number: **PCA - #74794**

Expiration Date: **12/31/2017**

City of San Diego Business License Number: **B1982012750**

Expiration Date: **11/30/2017**

APPENDIX G

SEWER MAINS AND MANHOLE REHABILITATION SAMPLE DATA TEMPLATES

REHAB DATE COLLECTION – SEWER MAINS

FSN	REHAB DATE	LENGTH	INSIDE DIAM	FUNCTIONAL DIAM	LINING TYPE DESC	LINING METHOD DESC	REHAB CONTRACTOR DESC	REHAB MATERIAL VENDOR	COMMENTS	ACCEPTANCE DATE
65112	8/22/2006	312	8	7	PVC	SPIRAL WOUND	WESCO INFRA. TECHNOLOGIES,LP	RIBLOC	EXAMPLE - Leave this row in the table as it is.	8/22/2006

REHAB DATA COLLECTION – MANHOLES

MH FSN	REHAB DATE	LINING TYPE	LINING MATERIAL VENDOR	LINING SYSTEM	REHAB CONTRACTOR	RIM ELEVATION	INVERT ELEVATION	ACTUAL DEPTH (VF)	COMMENTS	ACCEPTANCE DATE
70536	3/28/2007	POLYURETHANE	ZEBRON	ZEBRON 386	ZEBRON CORPORATION	49.8	41.95	7	Leave this row as a sample.	3/28/2007

APPENDIX H
SAMPLE ARCHAEOLOGY INVOICE

(FOR ARCHAEOLOGY ONLY)

Company Name

Address, telephone, fax

Date: Insert Date

To: Name of Resident Engineer
City of San Diego
Field Engineering Division
9485 Aero Drive
San Diego, CA 92123-1801

Project Name: Insert Project Name

SAP Number (WBS/IO/CC): Insert SAP Number

Drawing Number: Insert Drawing Number

Invoice period: Insert Date to Insert Date

Work Completed: Bid item Number – Description of Bid Item – Quantity – Unit Price– Amount

Detailed summary of work completed under this bid item: Insert detailed description of Work related to Archaeology Monitoring Bid item. See Note 1 below.

Summary of charges:

Description of Services	Name	Start Date	End Date	Total Hours	Hourly Rate	Amount
Field Archaeologist	Joe Smith	8/29/2011	9/2/2011	40	\$84	\$3,360
Laboratory Assistant	Jane Doe	8/29/2011	9/2/2011	2	\$30	\$60
Subtotal						\$3,420

Work Completed: Bid item Number – Description of Bid Item – Quantity – Unit Price– Amount

Detailed summary of work completed under this bid item: Insert detailed description of Work related to Archaeology Curation/Discovery Bid item. See Note 2 below.

Summary of charges:

Description of Services	Where work occurred (onsite vs offsite/lab)	Name	Start Date	End Date	Total Hours	Hourly Rate	Amount
Field Archaeologist		Joe Smith	8/29/2011	9/2/2011	40	\$84	\$3,360
Laboratory Assistant		Jane Doe	8/29/2011	9/2/2011	2	\$30	\$60
Subtotal							\$3,420

Total this invoice: \$ _____

Total invoiced to date: \$ _____

Note 1:

For monitoring related bid items or work please include summary of construction work that was monitored from Station to Station, Native American monitors present, MMC coordination, status and nature of monitoring and if any discoveries were made.

Note 2:

For curation/discovery related bid items or work completed as part of a discovery and curation process, the PI must provide a response to the following questions along with the invoice:

1. Preliminary results of testing including tentative recommendations regarding eligibility for listing in the California Register of Historical Resources (California Register).
 - a. Please briefly describe your application (consideration) of all four California Register criteria.
 - b. If the resource is eligible under Criterion D, please define the important information that may be present.
 - c. Were specialized studies performed? How many personnel were required? How many Native American monitors were present?
 - d. What is the age of the resource?
 - e. Please define types of artifacts to be collected and curated, including quantity of boxes to be submitted to the San Diego Archaeological Center (SDAC). How many personnel were required? How many Native American monitors were present?
2. Preliminary results of data recovery and a definition of the size of the representative sample.
 - a. Were specialized studies performed? Please define types of artifacts to be collected and curated, including quantity of boxes to be submitted to the SDAC. How many personnel were required? How many Native American monitors were present?
3. What resources were discovered during monitoring?
4. What is the landform context and what is the integrity of the resources?
5. What additional studies are necessary?
6. Based on application of the California Register criteria, what is the significance of the resources?
 - a. If the resource is eligible for the California Register, can the resource be avoided by construction?
 - b. If not, what treatment (mitigation) measures are proposed? Please define data to be recovered (if necessary) and what material will be submitted to the SDAC for curation. Are any specialized studies proposed?

(After the first invoice, not all the above information needs to be re-stated, just revise as applicable).

APPENDIX I
ADJACENT PROJECT

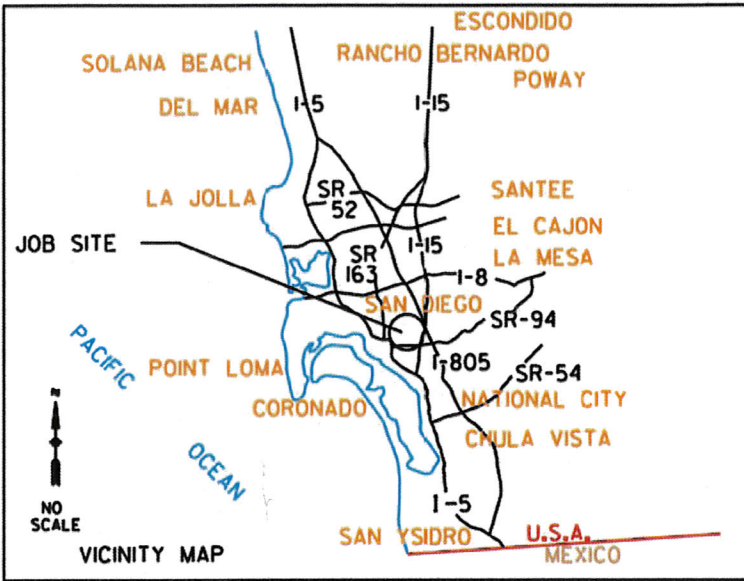

SENIOR ENGINEER
CARL SPIER, P.E.
☎ (619) 533-5126

PROJECT MANAGER
MAHMOUD ORI OAT, P.E.
☎ (619) 533-5232

PROJECT ENGINEER
ROBERTO DIAWATAN
☎ (619) 533-4208

CONSTRUCTION PROJECT
INFORMATION LINE
☎ (619) 533-4207

SEWER AND WATER MAIN REPLACEMENT

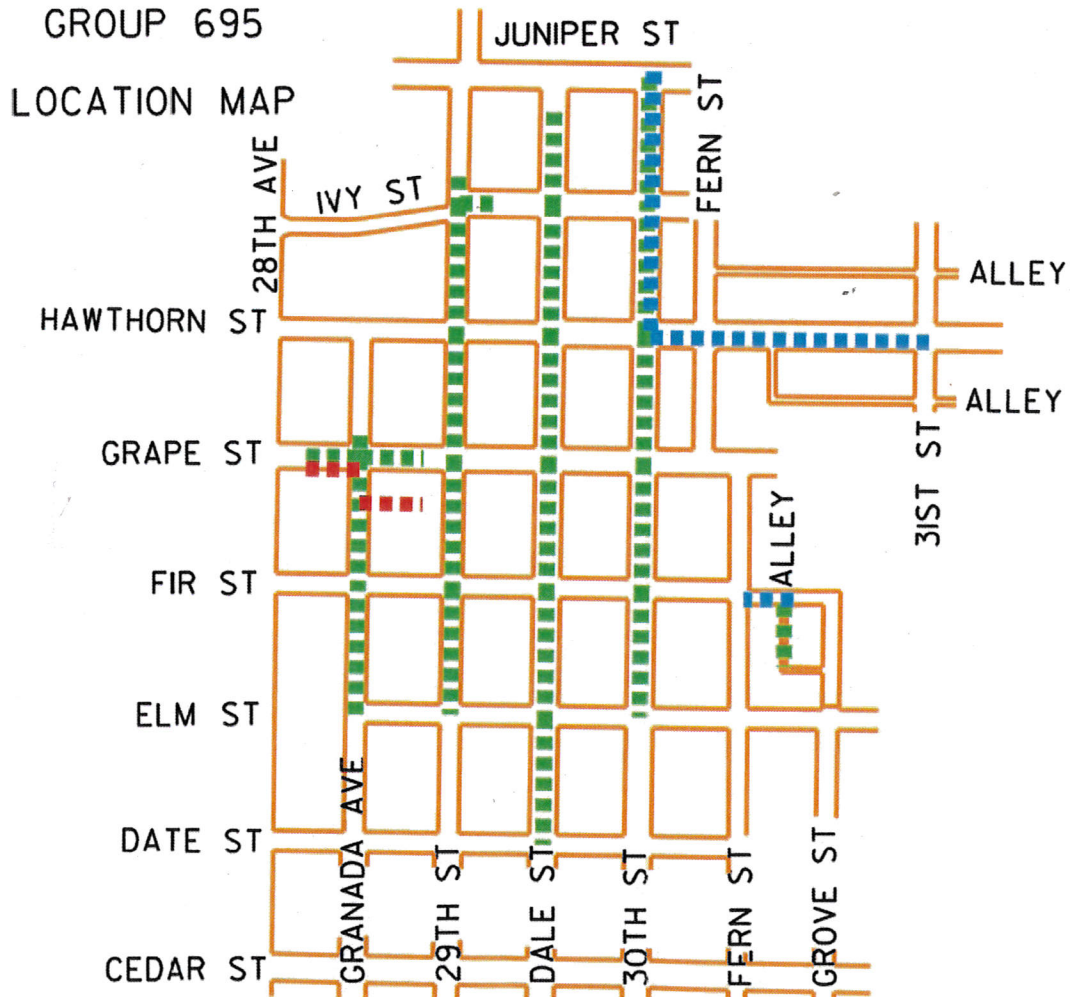

NO SCALE

LEGEND:

- 6-INCH SEWER MAIN REPLACEMENT
- 6-INCH & 2-INCH WATER MAIN REPLACEMENT
- ABANDON 6-INCH AND 8-INCH EXISTING SEWER MAIN

9-30-13 RD/NV

APPENDIX J

AGREEMENT FOR APPLICATION OF EMULSION – AGGREGATE SLURRY

AGREEMENT FOR APPLICATION OF EMULSION-AGGREGATE SLURRY

This Agreement for Application of Emulsion-Aggregate Slurry Related to **Sewer Group 691**, [Agreement] is made and entered into by and between the City of San Diego [City] and ***Insert name of Contractor*** [Contractor] (collectively referred to herein as “the Parties”).

RECITALS

- A. WHEREAS, on or about ***Insert date***, the City and the Contractor entered into an agreement for the construction of **Sewer Group 691**, [Contract], SAP No. **B-00446**.
- B. WHEREAS, in accordance with the terms of the Contract, the City and the Contractor agreed that the slurry sealing work described in Section 302-4, “SLURRY SEAL SURFACING,” Rubberized Emulsion Aggregate Slurry (REAS) would not be performed during the months of November, December, January, February, and March [Winter Months].
- C. WHEREAS, work progressed in accordance with the Contract such that the slurry sealing work would, in the absence of the Parties’ agreement to the contrary, be performed during the Winter Months.
- D. WHEREAS, the City and the Contractor desire to enter into this Agreement in order to fulfill their obligations under 302-4, “SLURRY SEAL SURFACING” and 302-4.7, “Rubberized Emulsion Aggregate Slurry” of the Contract.

NOW, THEREFORE, in consideration of the mutual obligations of the Parties as set forth in the above Recitals, which are incorporated herein by this reference, the City and the Contractor agree as follows.

ARTICLE I - WORK TO BE PERFORMED

1.1 Performance of Work.

The Contractor agrees to perform all slurry sealing work as set forth in Sections 302-4 and 302-4.7 of the Contract and **sheet _____ - ____-D of the Project’s Plans** [Slurry Work], which are incorporated by this reference as though fully set forth herein. The Slurry Work shall be performed in accordance with the Schedule of Work, attached hereto as “Exhibit A” and incorporated herein by this reference, or as otherwise agreed to by the Parties in a written change to the Schedule of Work. Unless otherwise specified, the time of completion of this Agreement shall be in Working Days.

For the purposes of this Agreement:

- a. References in the specified sections to the “Agency” shall mean the City and the “Work” shall mean the Slurry Work.
- b. References to the specified sections shall mean sections of the GREENBOOK (Standard Specifications for Public Works Construction), the City Supplements in The WHITEBOOK, and Supplementary Special Provisions (SSP) under the editions specified in the Contract.

1.2 Working Day.

See the City Supplements, Section 1-2, "TERMS AND DEFINITIONS." The Engineer will make a daily determination of each Working Day to be charged against the Agreement time. These determinations will be discussed and the Contractor will be furnished a periodic statement showing allowable number of Working Days of Agreement time, including any adjustments, at the beginning of the reporting period. The statement will also indicate the number of Working Days charged during the reporting period and the number of Working Days of Agreement time remaining. If the Contractor does not agree with the statement, it shall file a written protest within 15 days after receipt, setting forth the facts of the protest. Otherwise, the statement will be deemed to have been accepted.

1.3 Prosecution of Slurry Work.

Section 6-2, "Prosecution of the Work" is incorporated into this Agreement by this reference as though fully set forth herein.

1.4 Project Site Maintenance.

Section 7-8, "Work Site Maintenance" is incorporated into this Agreement by this reference as though fully set forth herein.

1.5 Protection and Restoration of Existing Improvements.

Section 7-9, "Protection and Restoration of Existing Improvements" is incorporated into this Agreement by this reference as though fully set forth herein.

1.6 Public Convenience and Safety.

Section 7-10, "Public Convenience and Safety" is incorporated into this Agreement by this reference as though fully set forth herein.

1.7 Completion, Acceptance, and Guarantee.

The Engineer will inspect the Slurry Work in accordance with Section 302-4 and 302-4.7 of the Contract. The Contractor shall provide the Engineer with written notice that the Slurry Work has been completed. If the Engineer determines that the Slurry Work has been completed to the Engineer's reasonable satisfaction and is ready for acceptance, the Engineer will accept the completed Work by sending written notice to the Contractor specifying the date of acceptance. All Slurry Work shall be subject to the warranty requirements of the Contract as specified in Section 6-8, "COMPLETION, ACCEPTANCE, AND WARRANTY."

1.8 Payment to Contractor.

Upon completion of the Slurry Work, the City will pay the Contractor for slurry work, bonds, insurance, and traffic control in accordance with the applicable sections of the Contract.

1.9 Delays and Extensions of Time.

Section 6-6, "Delays and Extensions of Time" is incorporated into this Agreement by this reference as though fully set forth herein.

1.10 Liquidated Damages.

Section 6-9, "Liquidated Damages" is incorporated into this Agreement by this reference as though fully set forth herein.

ARTICLE II - BOND/INSURANCE/INDEMNIFICATION

2.1 Faithful Performance Bond.

Prior to execution of this Agreement, the Contractor shall provide the City with a faithful performance bond [Bond] in the amount of \$[*insert amount of Contractor's bid item for slurry work], guaranteeing faithful performance of all Slurry Work, within the time prescribed in this Agreement, in a manner satisfactory to City, and that all materials and workmanship will be free from original or developed defects. The Bond must remain in effect until the end of all warranty periods set forth in this Agreement. The Bond shall comply with Section 2-4, "CONTRACT BONDS" of the Contract.

2.2 Insurance.

Section 7-3, "Liability Insurance" is incorporated into this Agreement by this reference as though fully set forth herein. At all times during the term of this Agreement, the Contractor shall maintain insurance coverage required by Section 7-3, "LIABILITY INSURANCE" of the Contract for:

- a. Commercial General Liability.
- b. Commercial Automobile Liability.
- c. Worker's Compensation.

All policies must be primary and non-contributing to any insurance that may be carried by the City, as reflected in an endorsement, which shall be submitted to the City. The policies shall not be canceled, non-renewed, or materially changed except after 30 days prior written notice by the Contractor or the insurance carrier to the City by certified mail, except for non-payment of premium, in which case 10 days notice shall be provided.

2.3 Indemnification.

Section 7-15, Indemnification and Hold Harmless Agreement is incorporated into this Agreement by this reference as though fully set forth herein.

ARTICLE III - DEFAULT/TERMINATION

3.1 Termination of the Contract for Default.

Section 6-4, "Termination of the Contract for Default" is incorporated into this Agreement by this reference as though fully set forth herein.

3.2 Termination of the Contract for Convenience.

Section 6-5, "Termination of the Contract for Convenience" is incorporated into this Agreement by this reference as though fully set forth herein.

ARTICLE IV - CONTRACTOR OBLIGATIONS

4.1 Compliance with the City's Equal Opportunity Contracting Program.

The Contractor and each Subcontractors shall comply with the City's Equal Opportunity Contracting Program requirements which the Contractor acknowledges receiving in conjunction with the Contract.

4.2 Non-Discrimination Ordinance.

The Contractor shall not discriminate on the basis of race, gender, religion, national origin, ethnicity, sexual orientation, age, or disability in the solicitation, selection, hiring or treatment of subcontractors, vendors or suppliers. The Contractor shall provide equal opportunity for subcontractors to participate in subcontracting opportunities. The Contractor understands and agrees that violation of this Section shall be considered a material breach of this Agreement and may result in contract termination, debarment, or other sanctions. This language shall be in contracts between the Contractor and Subcontractors, and Suppliers.

4.3 Compliance Investigations.

Upon the City's request, the Contractor agrees to provide to the City, within 60 days, a truthful and complete list of the names of all Subcontractors and Suppliers that the Contractor has used in the past 5 years on any of its contracts that were undertaken within San Diego County, including the total dollar amount paid by the Contractor for each subcontract or supply contract. The Contractor further agrees to fully cooperate in any investigation conducted by the City pursuant to the City's Nondiscrimination in Contracting Ordinance (Municipal Code sections 22.3501-22.3517.) The Contractor understands and agrees that violation of this clause shall be considered a material breach of the contract and may result in remedies being ordered against the Contractor up to and including contract termination, debarment, and other sanctions for violation of the provisions of the Nondiscrimination in Contracting Ordinance. The Contractor further understands and agrees that the procedures, remedies and sanctions provided for in the Nondiscrimination Ordinance apply only to violations of the Nondiscrimination Ordinance.

4.4 Drug-Free Workplace.

The Contractor agrees to comply with the City's Drug-Free Workplace requirements set forth in Council Policy 100-17, adopted by Council Resolution No. R-277952 and incorporated into this Agreement by this reference. The Contractor has certified to the City that it will provide a drug-free workplace by submitting a Contractor Certification for a Drug-Free Workplace form.

The Contractor further certifies that any subcontract for this Agreement shall contain language that binds the Subcontractor to comply with the drug-free workplace requirements of this Agreement, as required by Sections 2.A.(1) through (3) of Council Policy 100-17. The Contractor and Subcontractors shall be individually responsible for their own drug-free work place program.

4.5 Compliance with Controlling Law.

The Contractor shall comply with all laws, ordinances, regulations, and policies of the federal, state, and local governments applicable to this Agreement, including the California Labor Code. In addition, the Contractor shall comply immediately with all directives issued by the City or its authorized representatives under authority of any laws, statutes, ordinances, rules, or

regulations. The laws of the State of California shall govern and control the terms and conditions of this Agreement.

ARTICLE V - GENERAL PROVISIONS

5.1 Jurisdiction, Venue, and Attorney's Fees.

The venue for any suit or proceeding concerning this Agreement, the interpretation or application of any of its terms, or any related disputes shall be in the County of San Diego, State of California. The prevailing party in any such suit or proceeding shall be entitled to a reasonable award of attorney's fees in addition to any other award made in such suit or proceeding.

5.2 Successors in Interest.

This Agreement and all rights and obligations created by this Agreement shall be in force and effect whether or not any parties to the Agreement have been succeeded by another entity, and all rights and obligations created by this Agreement shall be vested and binding on any party's successor in interest.

5.3 Integration.

This Agreement and the exhibits and references incorporated into this Agreement fully express all understandings of the Parties concerning the matters covered in this Agreement. No change, alteration, or modification of the terms or conditions of this Agreement, and no verbal understanding of the Parties, their officers, agents, or employees shall be valid unless made in the form of a written change or an amendment to this Agreement agreed to by Parties. All prior negotiations and agreements are merged into this Agreement.

5.4 No Waiver.

No failure of either the City or the Contractor to insist upon the strict performance by the other of any covenant, term or condition of this Agreement, nor any failure to exercise any right or remedy consequent upon a breach of any covenant, term, or condition of this Agreement, shall constitute a waiver of any such breach or of such covenant, term or condition. No waiver of any breach shall affect or alter this Agreement, and each and every covenant, condition, and term hereof shall continue in full force and effect to any existing or subsequent breach.

5.5 Severability.

The unenforceability, invalidity, or illegality of any provision of this Agreement shall not render any other provision of this Agreement unenforceable, invalid, or illegal.

5.6 Drafting Ambiguities.

The Parties agree that they are aware that they have the right to be advised by counsel with respect to the negotiations, terms and conditions of this Agreement, and the decision of whether or not to seek advice of counsel with respect to this Agreement is a decision, which is the sole responsibility of each Party. This Agreement shall not be construed in favor of or against either Party by reason of the extent to which each Party participated in the drafting of the Agreement.

5.7 City Acts/Approvals.

Whenever an act or approval is required by the City in accordance with the terms of this Agreement, the Public Works Department Director or duly designated representative shall perform act or approval.

5.8 Signing Authority.

The representative for each Party signing on behalf of a corporation, partnership, joint venture or governmental entity hereby declares that authority has been obtained to sign on behalf of the corporation, partnership, joint venture, or entity and agrees to hold the other Party or Parties hereto harmless if it is later determined that such authority does not exist..

IN WITNESS WHEREOF, this Agreement is executed by the City of San Diego, by and through its Public Works Department Director in accordance with Resolution No. _____, and by Contractor.

THE CITY OF SAN DIEGO

APPROVED AS TO FORM AND LEGALITY

Jan I. Goldsmith, City Attorney

By _____

By _____

Print Name: _____
Mayor or designee

Print Name: _____
Deputy City Attorney

Date: _____

Date: _____

CONTRACTOR

By _____

Print Name: _____

Title: _____

Date: _____

EXHIBIT A
SCHEDULE OF WORK

ATTACHMENT F
INTENTIONALLY LEFT BLANK

City of San Diego

CITY CONTACT: Damian Singleton - Contract Specialist, Email: dsingleton@sandiego.gov

Phone No. (619) 533-3482, Fax No. (619) 533-3633

ADDENDUM "A"

FOR

SEWER GROUP 691



BID NO.:	K-15-5875-DBB-3-C
SAP NO. (WBS/IO/CC):	B-00446
CLIENT DEPARTMENT:	2011
COUNCIL DISTRICT:	3
PROJECT TYPE:	JA

BID DUE DATE:

**2:00 PM
SEPTEMBER 30, 2014
CITY OF SAN DIEGO
PUBLIC WORKS CONTRACTS
1010 SECOND AVENUE, 14th FLOOR, MS 614C
SAN DIEGO, CA 92101**

ENGINEER OF WORK

The engineering Specifications and Special Provisions contained herein have been prepared by or under the direction of the following Registered Engineer:



For City Engineer

9/25/14

Date

Seal:



A. CHANGES TO CONTRACT DOCUMENTS

The following changes to the Contract Documents are hereby made effective as though originally issued with the bid package. Bidders are reminded that all previous requirements to this solicitation remain in full force and effect.

B. PLANS

1. To DRAWING numbered 32506-01-D, **DELETE** in its entirety and **REPLACE** with page 4 of the Addendum "A".
2. To DRAWINGS numbered 32506-01-D through 32506-21-D, **ADD** Drawing Sheet 32506-22-D, page 5 of this Addendum "A".

James Nagelvoort, Director
Public Works Department

Dated: *September 25, 2014*
San Diego, California

JN/bd/lis

SEWER GROUP 691

CONTRACTOR'S RESPONSIBILITIES

- PURSUANT TO SECTION 4216 OF THE GOVERNMENT CODE, AT LEAST 2 WORKING DAYS PRIOR TO EXCAVATION, YOU MUST CONTACT THE REGIONAL NOTIFICATION CENTER (e.g., UNDERGROUND SERVICE ALERT OF SOUTHERN CALIFORNIA) AND OBTAIN AN INQUIRY IDENTIFICATION NUMBER.
- NOTIFY SDG&E AT LEAST 10 WORKING DAYS PRIOR TO EXCAVATING WITHIN 10' OF SDG&E UNDERGROUND HIGH VOLTAGE TRANSMISSION POWER LINES (1.0, 69 KV & HIGHER)
- LOCATE AND RECONNECT ALL SEWER LATERALS. LOCATIONS AS SHOWN ON THE PLANS ARE APPROXIMATE ONLY. LATERAL RECORDS ARE AVAILABLE TO THE CONTRACTOR AT THE PUBLIC UTILITIES DEPARTMENT, 2797 CAMINITO CHOLLAS. LOCATE THE IMPROVEMENTS THAT WILL BE AFFECTED BY LATERAL REPLACEMENTS.
- THE LOCATIONS OF EXISTING BUILDINGS AS SHOWN ON THE PLAN ARE APPROXIMATE.
- KEEP STORM DRAIN INLETS FUNCTIONAL AT ALL TIMES DURING CONSTRUCTION.
- UNLESS OTHERWISE NOTED AS PREVIOUSLY POTHOLED (PH), ELEVATIONS SHOWN ON THE PROFILE FOR EXISTING UTILITIES ARE BASED ON A SEARCH OF THE AVAILABLE RECORD INFORMATION ONLY AND ARE SOLELY FOR THE CONTRACTOR'S CONVENIENCE. THE CITY DOES NOT GUARANTEE THAT IT HAS REVIEWED ALL AVAILABLE DATA. THE CONTRACTOR SHALL POTHOLE ALL EXISTING UTILITIES EITHER SHOWN ON THE PLANS OR MARKED IN THE FIELD IN ACCORDANCE WITH THE SPECIFICATIONS SECTION 5-1.
- EXISTING UTILITY CROSSING AS SHOWN ON THE PLANS ARE APPROXIMATE AND ARE NOT REPRESENTATIVE OF ACTUAL LENGTH AND LOCATION OF CONFLICT AREAS. SEE PLAN VIEW.

LIMITS OF WORK

SHEET NO.	DISCIPLINE CODE	TITLE	LIMITS	PIPE		LENGTH (FT)
				SIZE (IN)	MATERIAL	
1	G-1	COVER SHEET	HAWTHORN TO GRAPE ST	8	SEWER	134.00
2	C-1	28TH STREET	HAWTHORN TO GRAPE ST	6	REHAB	16.00
3	C-2	28TH STREET	28TH ST TO GRANADA AVE	8	SEWER	200.00
4	C-3	28TH STREET/IVY STREET	N/O HAWTHORN ST TO IVY/28TH ST TO 29TH ST	8	SEWER	723.00
5	C-4	ALLEY BLK A, B, 7, & 8	E/O 30TH ST TO E/O 31ST ST	8	SEWER	600.00
6	C-5	ALLEY BLK B & 7	E/O 31ST ST TO 32ND ST	8	SEWER	354.73
7	C-6	JUNIPER ST	W/O 28TH ST TO 29TH ST	8	SEWER	700.00
8	C-7	JUNIPER ST/29TH ST	JUNIPER ST TO ALLEY BLK 8, 68	8	SEWER	294.80
8	C-7	ALLEY BLK 8, 68	29TH ST TO 30TH ST	8	SEWER	695.44
9	C-8	30TH STREET	S/O KALMIA ST	8	SEWER	97.01
9	C-8	KALMIA PLACE	W/O 29TH ST	-	-	-
10	C-9	EASEMENT BLK H & N	N/O BURLINGAME DR TO MAPLE ST	8	REHAB	220.06
11	C-10	30TH STREET	MAPLE CT TO KALMIA ST	8	SEWER	190.20
12	C-II	SAN MARCOS AVENUE	N/O LAUREL ST	-	-	-
TOTAL SEWER 4360.24						
13	C-12	SEWER ABANDONMENT SHEET				
14	C-13	REPLUMB DETAILS				
15	C-14	REPLUMB DETAILS				
16	C-15	REPLUMB DETAILS				
17	C-16	REPLUMB DETAILS				
18	C-17	REPLUMB DETAILS				
19	C-18	STREET RESURFACING				
20	C-19	CURB RAMP LOCATION				
21	C-20	HORIZONTAL ALIGNMENT COORDINATE INDEX REPORT				
22	L-1	REVEGETATION SHEET				

DISCIPLINE CODE

- G GENERAL
- C CIVIL
- L LANDSCAPE

STORM WATER PROTECTION

- THIS PROJECT IS SUBJECT TO MUNICIPAL STORM WATER PERMIT ORDER NO. R9-2007-0001 AND WPCP.

ABBREVIATIONS

ABAND	ABANDON	EB	ENCASED BURIED	OVHD	OVER HEAD
ABAND'D	ABANDONED	EL, ELEV	ELEVATION	PVC	POLYVINYL CHLORIDE
AC	ASBESTOS CEMENT PIPE	ELEC	ELECTRIC	PROP	PROPOSED
AHD	AHEAD	EX, EXIST	EXISTING	RED	REDUCER
ASSY	ASSEMBLY	E/O	EAST OF	RT	RIGHT
BK	BACK	F	FLANGE	S	SURVEY LINE
BTWN	BETWEEN	GV	GATE VALVE	SO	STUB OUT
CATV	CABLE TV	HDPE	HIGH-DENSITY POLYETHYLENE	S/O	SOUTH OF
CI	CAST IRON PIPE	HP	HIGH PRESSURE	SWR	SEWER
C	CENTER LINE	IE	INVERT ELEVATION	TEL	TELEPHONE
COND	CONDUIT	LT	LEFT	UNK	UNKNOWN
CONT	CONTINUED	MJ	MECHANICAL JOINT	VC	VITRIFIED CLAY PIPE
CONTR	CONTRACTOR	MTD	MULTIPLE TELEPHONE DUCT	WM	WATER METER
DB	DIRECT BURIED	N/O	NORTH OF	WTR	WATER
				W/O	WEST OF

EXISTING STRUCTURES

EX WATER MAIN & VALVES	---
EX WATER METER	○
EX FIRE HYDRANT	○
EX SEWER MAIN & MANHOLES	○
EX DRAINS	---
EX PAVEMENT (PROFILE)	
EX GROUND LINE (PROFILE)	
EX TRAFFIC SIGNAL	⊕
EX STREET LIGHT	⊕
GAS MAIN	---
ELEC. COND., TEL. COND., CATV	---E---T---C---
RAILROAD, TROLLEY TRACKS	

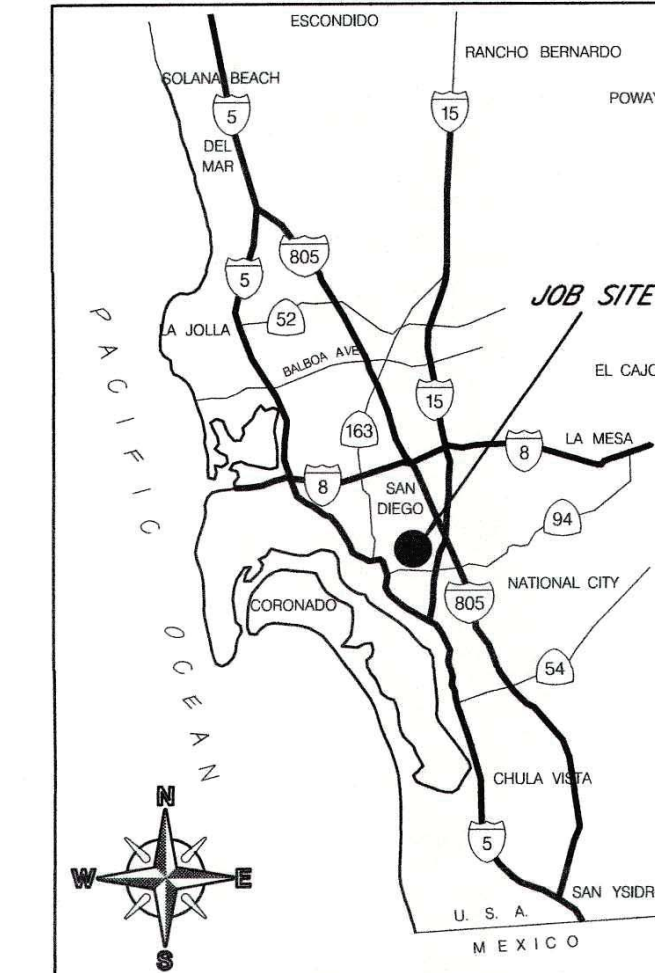
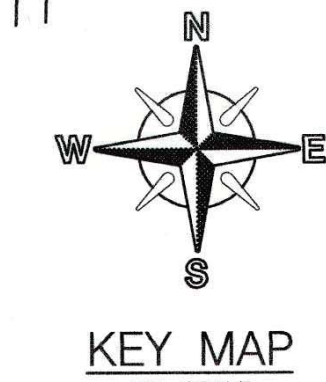
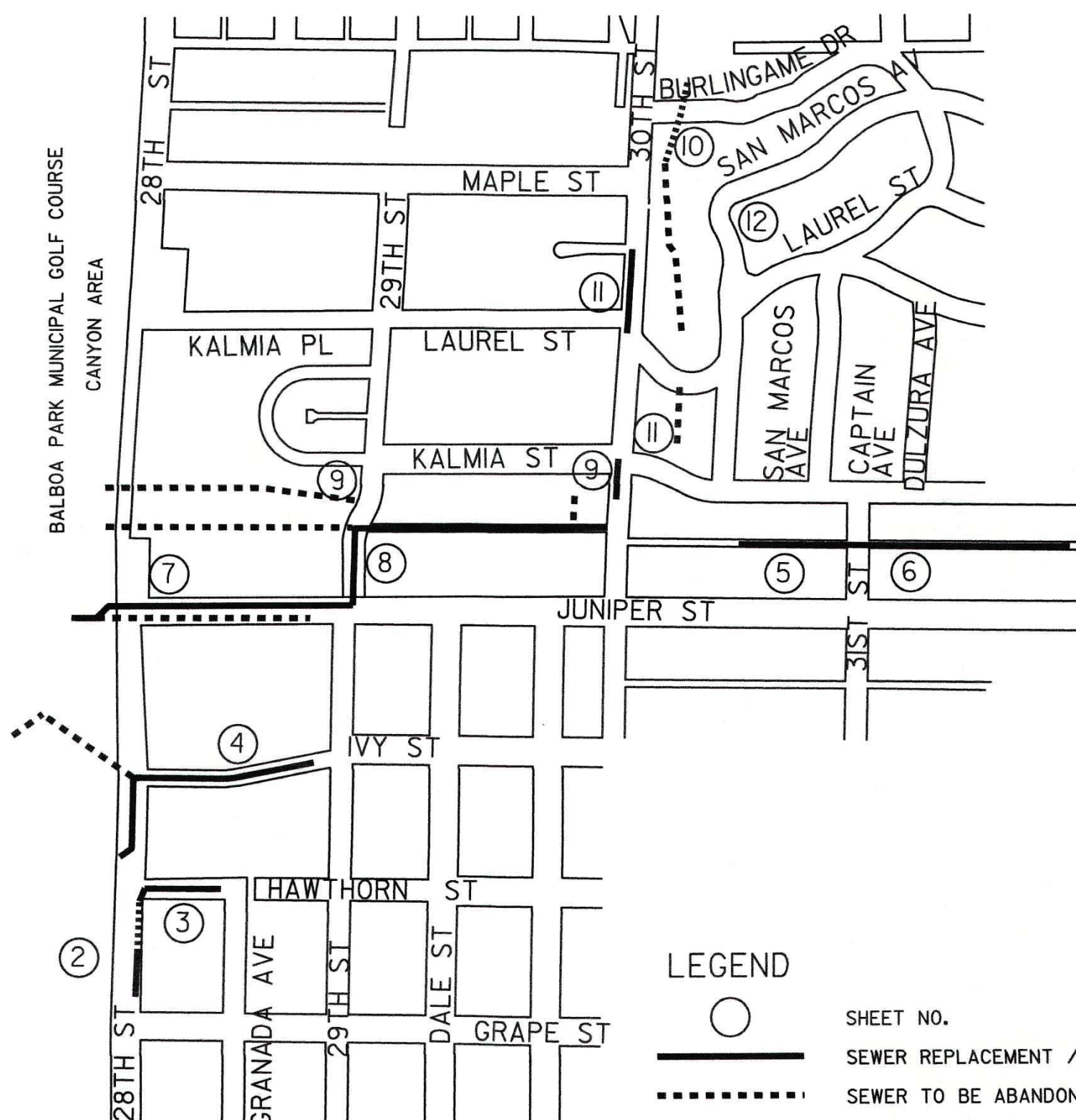

LEGEND

○	SHEET NO.
---	SEWER REPLACEMENT / NEW
---	SEWER TO BE ABANDONED
---	SEWER TO BE REHABILITATED

WORK TO BE DONE

CONSTRUCTION OF SEWER GROUP 691 CONSISTS OF THE REPLACEMENT OF APPROXIMATELY 4,360 LINEAR FEET (LF) OF PIPE, CONSISTING OF OPEN TRENCH REPLACEMENT, SEWER MAIN REHABILITATION, SEWER MAIN ABANDONMENT, WITH REPLACEMENT AND REPLUMB SEWER LATERALS, RESURFACING AND CURB RAMP REPLACEMENTS, AND ALL OTHER WORK AND APPURTENANCES IN ACCORDANCE WITH THESE SPECIFICATIONS AND DRAWINGS NUMBERED 32506-01 THROUGH 32506-21-D.

IMPROVEMENTS

- TRENCH RESURFACING
- SEWER MAIN
- SEWER MANHOLE/PVC LINED
- REHAB. EX. SEWER MANHOLE
- SEWER MAIN REHAB.
- 4' SEWER LATERAL WITH C.O. UNLESS OTHERWISE SPECIFIED
- REPLUMB SEWER LATERAL WITH C.O.
- SEWER LATERAL CONNECTION
- SEWER PUMP INCLUDING REPLUMB SEWER LATERAL WITH C.O.
- SERVICE LATERAL CONNECTION TO REHABILITATED SEWER
- TUNNEL SEWER REPLUMB LATERAL WITH C.O.
- PIPE SUPPORT FOR UNDERCUT AC WATER MAIN
- ABANDON EX MANHOLE
- SLURRY FILL ABANDONED SEWER MAIN
- CONCRETE ANCHOR
- CUTOFF WALL
- SURVEY MONUMENT

LEGEND

STANDARD DRAWINGS	SYMBOL
SDG-107 TYPE A, SDG-108	---
SEE PLANS & SPECS	○
SEE PLANS & SPECS	○
SDS-102, SDS-103, SDS-104, SDS-105, SDS-110 (TYPE C), SDS-118	○
SEE PLANS & SPECS	○
SDS-102, SDS-103, SDS-104, SDS-105, SDS-110 (TYPE C), SDS-118	○
SEE PLANS & SPECS	○
SDS-102, SDS-103, SDS-104, SDS-105, SDS-110 (TYPE C), SDS-118	○
SEE PLANS & SPECS	○
SDS-102, SDS-103, SDS-104, SDS-105, SDS-110 (TYPE C), SDS-118	○
SDW-162	---
SM-08	---
SEE PLANS & SPECS	---
SDS-114, SDW-162	---
SDS-115, SDW-162	---
M-10	---

CONSTRUCTION CHANGE / ADDENDUM

CHANGE	DATE	AFFECTED OR ADDED SHEET NUMBERS	APPROVAL NO.
A	9/25/14	NEW SHEET 22	

WARNING

IF THIS BAR DOES NOT MEASURE 1" THEN DRAWING IS NOT TO SCALE.

**CITY OF SAN DIEGO
PUBLIC WORKS PROJECT**



AS-BUILT INFORMATION

MATERIALS	MANUFACTURER
PIPE CL 235 (WATER)	-
PIPE SDR 35 (SEWER)	-
GATE VALVES	-
FIRE HYDRANTS	-
SEWER MANHOLES	-
REHABILITATE SEWER MANHOLES	-
REHABILITATE SEWER MAIN	-



PLANS FOR THE CONSTRUCTION OF SEWER GROUP 691 COVER SHEET

CITY OF SAN DIEGO, CALIFORNIA
PUBLIC WORKS DEPARTMENT
SHEET 01 OF 22 SHEETS

APPROVED: *Luis A. Schaar* 9/25/14
FOR CITY ENGINEER
LUIS A. SCHAAR
DATE

DATE STARTED: _____
DATE COMPLETED: _____

WATER WBS: _____
SEWER WBS: B-00446

SUBMITTED BY: JERICO GALLARDO
PROJECT MANAGER

JOSELITO GUINTO
PROJECT ENGINEER

SEE SHEETS
CC327 COORDINATE

SEE SHEETS
CC383 COORDINATE

CONTRACTOR: _____
INSPECTOR: _____

32506-01-D

ADDENDUM A: REVISED LIMITS OF WORK & SHEET TOTAL

SEWER GROUP 691

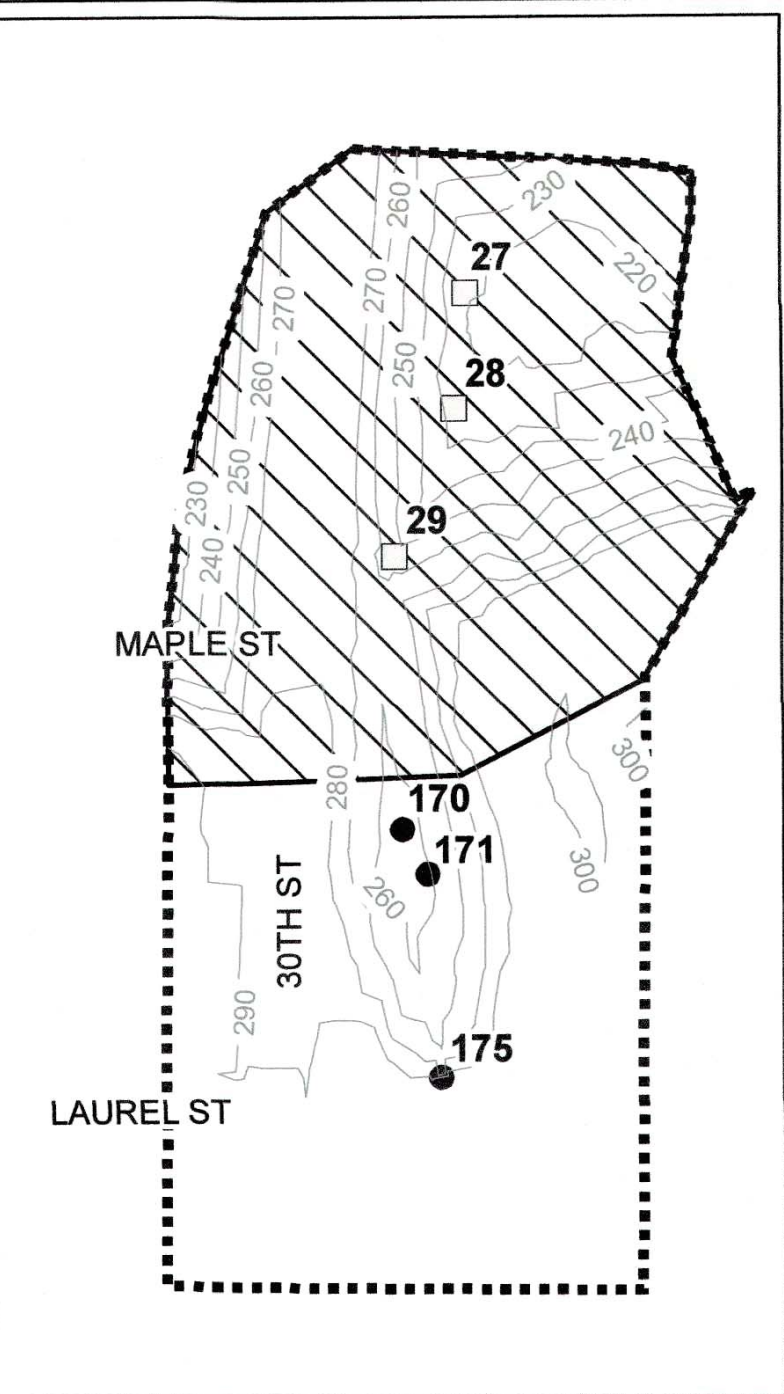
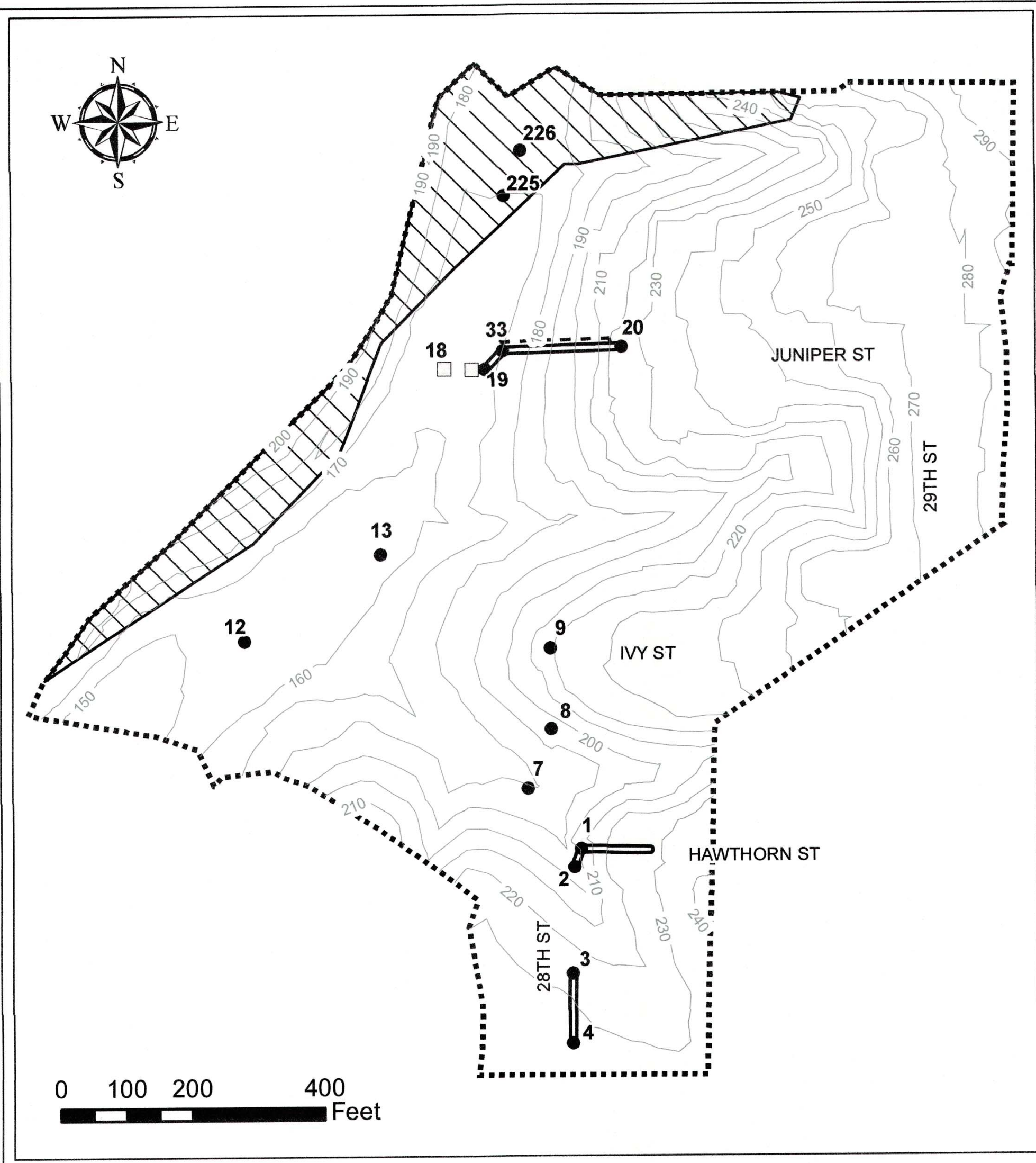

- Open Trench Restoration Areas**
 - sewer replacement or new alignment
- Access Path Restoration Areas**
 - 8 foot wide temporary access path
- Trenchless Restoration Areas**
 - sewer abandonment or rehabilitation (5 foot radius impact area)
 - pipebursting (10x10 foot impact area)
- Other**
 - study area
 - City of San Diego MHPA
 - 10ft contour lines

IMPACTED AREA TO BE RESTORED - 0.075 ac

NOTES COMMON TO PLANTING AREAS

1. SEED TAGS SHALL BE SUBMITTED TO THE PROJECT BIOLOGIST PRIOR TO APPLICATION OF SEED.
2. THE SEED MIX IS COMPRISED OF NATIVE PLANT SPECIES. ANY POTENTIAL SUBSTITUTIONS MUST BE APPROVED BY THE PROJECT BIOLOGIST PRIOR TO APPLICATION OF SEED.
3. % PLS IS THE MINIMUM PERCENT PURE LIVE SEED PER POUND OF SEED. THE PERCENTAGE IS CALCULATED BY MULTIPLYING THE PERCENT SEED PURITY BY PERCENT SEED GERMINATION, WHICH SHALL BE THE METHOD USED BY THE PROJECT BIOLOGIST TO DETERMINE SEED QUALITY, UNLESS THE BIOLOGIST SPECIFICALLY REQUEST THE %PLS METHOD TO BE USED.

HYDROSEED SEED PALETTE (0.075 ACRE)

Species	Common Name	Density Lbs./Acre	Purity/Germination
<i>Bacharis pilularis</i>	coyote brush	3	10/50
<i>Bromus carinatus</i> "Cucamonga"	Cucamonga brome	4	2/40
<i>Eriogonum fasciculatum</i>	flat-top buckwheat	5	95/80
<i>Melica imperfecta</i>	coast range melic	8	10/65
<i>Salvia mellifera</i>	black sage	4	90/60
<i>Trifolium tridentatum</i>	tomcat clover	4	95/85
<i>Vulpia microstachys</i>	small fescue	6	95/70
TOTAL:		34	

* PURE LIVE SEED

HYDROSEED SLURRY COMPONENTS

Product	Lbs./Acre
Cellulose Fiber Mulch	2,000
Hydropost Compost	2,000
Humate Tri-C Organic Soil Conditioner	500
SoilBuster Pelletized Calcium Sulfate Gypsum Alternative	1,200
Super Tack	150

TABLE 1: SUCCESS CRITERIA*

PARAMETER	PERCENT VEGETATION COVER
	HYDROSEED
PERFORMANCE STANDARD - IMPACT AREA	YEAR 1: 50 PERCENT 25 MONTHS: 100 PERCENT

* SEE GENERAL REVEGETATION NOTE #4 IF LOWER PERCENT APPROVED BY PROJECT BIOLOGIST.
** HYDROSEED VEGETATIVE COVER NOT MEETING PLANT SURVIVAL SUCCESS CRITERIA, AS VERIFIED AND RECOMMENDED BY THE PROJECT BIOLOGIST, SHALL BE RE-SEEDED AND MAINTAINED AT CONTRACTORS EXPENSE UNTIL THE SUCCESS CRITERIA HAS BEEN MET.

GENERAL REVEGETATION NOTES:

1. REVEGETATION OF THE PROJECT AREA SHALL BE IN ACCORDANCE WITH THE LATEST EDITION OF THE CITY OF SAN DIEGO LANDSCAPE STANDARDS.
2. REVEGETATION OF THE SITE IS TO BE PERFORMED WITH AN APPLICATION OF A NATIVE SEED MIX HYDROSEED SLURRY.
3. THESE PLANS ARE TO BE USED AS A GENERAL GUIDE WITH THE FINAL LAYOUT TO BE DETERMINED ON-SITE BY THE PROJECT BIOLOGIST.
4. SEED MIX USED FOR EROSION CONTROL SHALL ACHIEVE 100 PERCENT (OR AS APPROVED BY THE PROJECT BIOLOGIST AND CITY REPRESENTATIVE BASED ON SITE CONDITIONS IF LESSER % COVERAGE) SOIL COVERAGE WITHIN 25 MONTHS OF BEING INSTALLED AFTER THE 120 DAY PLANT ESTABLISHMENT PERIOD (PEP). AT THE END OF YEAR 1, PLANT COVERAGE SHALL MEET 50 PERCENT COVERAGE, AS VERIFIED BY THE PROJECT BIOLOGIST (TABLE 1).
5. INVASIVE PLANT SPECIES INCLUDING BUT NOT LIMITED TO THOSE LISTED IN THE CITY'S LANDSCAPE STANDARDS ARE PROHIBITED; AND NATIVE PLANT SPECIES SHALL BE USED IN NATURALIZED AREAS.
6. REVEGETATION AND EROSION CONTROL TIMING - ALL REQUIRED REVEGETATION AND EROSION CONTROL SHALL BE COMPLETED WITHIN 30 DAYS OF THE COMPLETION OF GRADING OR DISTURBANCE TO AVOID POTENTIAL IMPACTS TO NESTING BIRD SPECIES AND TO TAKE ADVANTAGE OF COOLER SEASONAL TEMPERATURES AND INCREASED PRECIPITATION.
7. CONTRACTOR SHALL REPAIR AND/OR REPLACE ALL ABOVE GROUND EROSION CONTROL BMP'S DAMAGED DURING THE 120 PEP AND 25 MONTH MAINTENANCE AND MONITORING PERIOD. ANY ABOVE GRADE EROSION CONTROL MEASURES SUCH AS BUT NOT LIMITED TO SILT FENCING, GRAVEL BAGS AND/OR FIBER ROLLS SHALL BE REMOVED BY THE CONTRACTOR AND AS DIRECTED BY THE PROJECT BIOLOGIST FOLLOWING ACCEPTANCE OF THE 25 MONTH MAINTENANCE AND MONITORING PERIOD BY CITY REPRESENTATIVE AND PROJECT BIOLOGIST.
8. CONTRACTOR SHALL REMOVE ALL TRASH AND/OR DEBRIS FROM THE REVEGETATION SITE PRIOR TO AND FOLLOWING THE REVEGETATION INSTALLATION, AND UNTIL THE END OF THE 25 MONTH MAINTENANCE AND MONITORING PERIOD.

SITE PREPARATION:

1. NON-NATIVE HERBACEOUS, SHRUB, AND TREE SPECIES CURRENTLY OCCUPYING AREAS OF THE PROJECT AREA THAT WERE PREVIOUSLY DISTURBED, SHALL BE REMOVED OR TREATED WITH HERBICIDE.
2. NON-NATIVE SPECIES WITH VEGETATION THAT OVERHANGS POTENTIAL RESTORATION AREAS MAY BE TRIMMED OR PRUNED TO PROVIDE INCREASED LIGHT AND LIMIT SEED-DROP ONTO NEARBY AREAS. ALL TRIMMING OF NON-NATIVE VEGETATION SHALL BE PERFORMED IN THE PRESENCE OF THE PROJECT BIOLOGIST TO ENSURE THAT THERE ARE NO IMPACTS TO NESTING BIRDS IF TRIMMING IS PERFORMED BETWEEN THE MONTHS OF FEBRUARY AND SEPTEMBER.
3. ALL NON-NATIVE SPECIES TO BE TREATED, REMOVED, TRIMMED, OR PRUNED WILL BE FLAGGED IN ADVANCE BY THE PROJECT BIOLOGIST. THE APPLICANT'S LANDSCAPE CONTRACTOR SHALL COORDINATE WITH THE PROJECT BIOLOGIST REGARDING IDENTIFICATION OF EXOTIC WEED SPECIES TO BE REMOVED/TREATED.
4. IF EROSION CONTROL MATERIALS SUCH AS SILT FENCING AND FIBER ROLLS REMAIN ON SITE PRIOR TO PLANTING, THEY MUST BE IN A SERVICEABLE CONDITION PRIOR TO THE RESTORATION IMPLEMENTATION AND SHOULD REMAIN IN PLACE. IF THEY ARE DEGRADED HOWEVER, THEY SHOULD BE REPLACED PRIOR TO PLANTING AND HYDROSEEDING THE AREA, AND SHALL REMAIN UNTIL VEGETATION HAS BEEN ESTABLISHED.
5. IF NO EROSION CONTROL MATERIALS ARE IN PLACE FOLLOWING CONSTRUCTION, COMPOST SOXX OR SIMILAR AS DIRECTED BY THE BIOLOGIST SHOULD BE INSTALLED AT APPROXIMATE 15-FOOT INTERVALS ALONG THE SLOPE AND EXTEND AT LEAST 18 INCHES INTO ADJACENT VEGETATION.

TEMPORARY IRRIGATION:

1. AT THE DISCRETION OF THE BIOLOGIST, TEMPORARY IRRIGATION WILL BE APPLIED AS FOLLOWS:
2. HYDROSEED MUST BE INSTALLED TO COINCIDE WITH THE RAINY SEASON BETWEEN OCTOBER 1 AND FEBRUARY 15, OR AS DIRECTED BY THE PROJECT BIOLOGIST. IF PLANTING IS PERFORMED OUTSIDE OF THIS TIME, CONTRACTOR WILL BE REQUIRED TO PREPARE A TEMPORARY IRRIGATION PLAN TO BE APPROVED BY THE CITY AND PROJECT BIOLOGIST.
3. TEMPORARY IRRIGATION VIA TRUCK SHALL BE PROVIDED FOR A PERIOD SUFFICIENT TO ESTABLISH PLANT MATERIAL AND TO PROVIDE VEGETATIVE COVER THAT PREVENTS SOIL EROSION. THE AMOUNT OF IRRIGATION MUST BE ADJUSTED WHEN WARRANTED BY SITE CONDITIONS. PROJECT BIOLOGIST AND LANDSCAPE CONTRACTOR SHALL MONITOR TO DETERMINE SUCCESS AND ADDED REQUIREMENT FOR TEMPORARY IRRIGATION. IRRIGATION MAY NOT BE REQUIRED IF SEASONAL RAINFALL PROVIDES SUITABLE CONDITIONS FOR THE GERMINATION AND ESTABLISHMENT OF NATIVE HYDROSEEDED SPECIES.
4. IRRIGATION SHALL BE PERFORMED IN A MANNER THAT AVOIDS RUNOFF, SEEPAGE, AND OVERSPRAY ONTO ADJACENT PROPERTIES, NON-IRRIGATED AREAS, WALLS, ROADWAYS, OR STRUCTURES.
5. THE WATER DELIVERY RATE SHALL BE MATCHED TO THE SLOPE GRADIENT AND THE PERCOLATION RATE OF SOIL.
6. IRRIGATION SHALL DELIVER WATER SUFFICIENTLY AND UNIFORMLY AND SHALL BE APPROPRIATE TO THE NEEDS OF THE PLANT MATERIALS. RECOMMENDED REFERENCE MATERIALS FOR IRRIGATION SYSTEMS DESIGN ARE LISTED IN THE APPENDIX "A" OF THE CITY'S LANDSCAPE STANDARDS.
7. OVERWATERING AS EVIDENCED BY SOGGY SOILS, CONTINUALLY WET PAVEMENT, STANDING WATER, RUNOFF IN STREET GUTTERS AND OTHER SIMILAR CONDITIONS SHALL BE PREVENTED.
8. IF WATERING IS UTILIZED FOR THE PROJECT, IRRIGATION TRUCKS AND/OR EQUIPMENT SHALL REMAIN ON DESIGNATED ACCESS PATHS AND SHALL NOT IRRIGATE BEYOND THE REVEGETATION BOUNDARY.
9. TEMPORARY IRRIGATION MATERIALS SHALL BE PLACED SO THAT THEY CAN BE DRIVEN OVER OR DO NOT IMPEDE ACCESS TO UTILITIES (I.E. MANHOLES).

SEED MIXES:

1. THE SEED MIX IN TABLES IDENTIFIED SHALL BE APPLIED IN ALL NON HARDSCAPED AREAS DISTURBED BY THE PROJECT. THE SEED SHALL BE INSTALLED VIA HYDROSEED METHODS, UNLESS OTHERWISE DIRECTED BY THE PROJECT BIOLOGIST.
2. ALL SEEDS SHALL MEET THE MINIMUM % PURE LIVE SEED AS NOTED IN TABLES. IF MINIMUM % PURE LIVE SEED COUNT CANNOT BE MET CONTRACTOR TO COORDINATE AND OBTAIN WRITTEN APPROVAL FROM THE PROJECT BIOLOGIST FOR ALTERNATIVE COMPLIANCE.
3. ALL SEEDS SHALL ORIGINATE FROM WITHIN A 25 MILE RADIUS OF THE PROJECT SITE OR CONTRACTOR TO PROVIDE EVIDENCE THAT THE SEED IS NOT AVAILABLE AND NOTIFY THE CITY REPRESENTATIVE AND THE PROJECT BIOLOGIST FOR ALTERNATIVE COMPLIANCE.

HYDROSEEDING PROCEDURES:

1. AREAS TO BE HYDROSEEDED SHALL INCLUDE ACCESS PATHS, WORK AREAS ADJACENT TO WATER PIPELINE AND STAGING AREA AND ALL OTHER AREAS DEVOID OF VEGETATION WITHIN THE LIMITS OF THE PROJECT. AN AREA APPROXIMATELY 0.075-ACRE IN SIZE HAS BEEN IDENTIFIED FOR HYDROSEEDING.
2. HYDROSEEDING SHALL BE PERFORMED AFTER ALL CONTAINER PLANTINGS HAVE BEEN INSTALLED IN ORDER TO LIMIT DISTURBANCE OF THE INTACT HYDROSEED MATRIX.
3. SEEDING SHALL OCCUR ONLY AFTER THE PROJECT BIOLOGIST HAS OBSERVED AND APPROVED THAT THE SITE HAS BEEN PROPERLY PREPARED.
4. CELLULOSE FIBER MULCH SHALL BE APPLIED AT THE MINIMUM RATE OF 2,000 POUNDS PER ACRE OR AS DIRECTED BY THE PROJECT BIOLOGIST. ALTERNATIVELY, BONDED FIBER MATRIX (BFM) COULD BE UTILIZED IF SITE-SPECIFIC CONDITIONS WARRANT ITS USE (STEEP SLOPES, INCREASED MOISTURE RETENTION, ETC.).
5. HUMATE TRI-C ORGANIC SOIL CONDITIONER, OR EQUAL, SHALL BE APPLIED AT THE MINIMUM RATE OF 500 POUNDS PER ACRE, OR AS DIRECTED BY THE PROJECT BIOLOGIST.
6. SOILBUSTER PELLETIZED CALCIUM SULFATE GYPSUM ALTERNATIVE SHALL BE APPLIED AT THE MINIMUM RATE OF 1,200 POUNDS PER ACRE, OR AS DIRECTED BY THE PROJECT BIOLOGIST.
7. SUPER TACK SHALL BE APPLIED AT THE MINIMUM RATE OF 150 POUNDS PER ACRE OR AS DIRECTED BY THE PROJECT BIOLOGIST.
9. EQUIPMENT USED FOR THE APPLICATION OF SLURRY SHALL HAVE A BUILT-IN AGITATION SYSTEM TO SUSPEND AND HOMOGENEOUSLY MIX THE SLURRY. THE SLURRY MIX SHALL BE DYED GREEN. THE EQUIPMENT MUST HAVE A PUMP CAPABLE OF APPLYING SLURRY UNIFORMLY.
10. HYDROSEED MUST BE INSTALLED TO COINCIDE WITH THE RAINY SEASON BETWEEN OCTOBER 1 AND FEBRUARY 15, OR AS DIRECTED BY THE PROJECT BIOLOGIST. IF PLANTING IS PERFORMED OUTSIDE OF THIS TIME, CONTRACTOR WILL BE REQUIRED TO PREPARE A TEMPORARY IRRIGATION PLAN TO BE APPROVED BY THE CITY AND PROJECT BIOLOGIST.

MAINTENANCE REQUIREMENTS:

1. REVEGETATION AREA SHALL BE MAINTAINED FOR A PERIOD OF NOT LESS THAN 25 MONTHS (TABLE 2). ALL REVEGETATED AREAS SHALL BE MAINTAINED BY THE PERMITTEE UNTIL FINAL APPROVAL BY THE CITY. THE MAINTENANCE PERIOD BEGINS ON THE FIRST DAY FOLLOWING ACCEPTANCE (AT END OF 120 DAY PEP) AND MAY BE EXTENDED AT THE DETERMINATION OF THE CITY REPRESENTATIVE.
2. PRIOR TO FINAL APPROVAL, THE CITY REPRESENTATIVE MAY REQUIRE CORRECTIVE ACTION INCLUDING BUT NOT LIMITED TO REPLANTING AND THE REPAIR OF ANY SOIL EROSION OR SLOPE SLIPPAGE, IN CONSULTATION WITH THE PROJECT BIOLOGIST.
3. THE 120 PEP FOLLOWS HYDROSEED APPLICATION. THE PEP AND START OF 25 MONTHS MAINTENANCE AS WELL AS ACCEPTANCE FOLLOWING THE MAINTENANCE PERIOD IS DETERMINED BY CITY REPRESENTATIVE IN CONSULTATION WITH PROJECT BIOLOGIST.
4. WEEDING AND/OR HERBICIDE APPLICATION SHALL BE DONE REGULARLY BY THE CONTRACTOR. WEEDING SHALL BE DONE AT A MINIMUM OF BIWEEKLY UNTIL THE END OF THE 120 DAY PEP AND MONTHLY THROUGHOUT THE 25 MONTHS OF MAINTENANCE. CONTRACTOR SHALL OBTAIN APPROVAL FROM CITY REPRESENTATIVE AND PROJECT BIOLOGIST PRIOR TO HERBICIDE APPLICATION, AND APPLY HERBICIDE PER MANUFACTURER'S RECOMMENDATION AND ANY STATE OF CALIFORNIA GUIDELINES. HERBICIDE SHALL BE SUPERVISED OR APPLIED BY A PERSON POSSESSING A PESTICIDE APPLICATORS LICENSE ISSUED BY THE CALIFORNIA DEPARTMENT OF PESTICIDE REGULATION. HERBICIDE SHALL BE USED ONLY FOR HARD TO CONTROL WEEDS INCLUDING, BUT NOT LIMITED TO HOT TENTOT FIG (*CARPOBROTUS EDULIS*), GIANT REED (*ARUNDO DONAX*), TAMARISK (*TAMARIX SPP.*), BERMUDA GRASS (*CYNODON DACTYLON*), AND PAMPAS GRASS (*CORTADERIA SELLOANA*).
5. CONTRACTOR SHALL CONTROL WEEDS AS IDENTIFIED BY THE PROJECT BIOLOGIST SUCH THAT NO WEED COVER EXCEEDS 5% OF THE PROJECT SITE, BEFORE THEY EXCEED TWELVE INCHES (12") IN HEIGHT, AND BEFORE THEY SET SEED.

TABLE 2: SUMMARY AND SCHEDULE FOR MAINTENANCE, MONITORING, AND REPORTING FOR PROJECT

PERIOD	ACTIVITY FOR PROJECT BIOLOGIST/CONTRACTOR	BIOLOGIST SITE VISIT FREQUENCY	SUBMITTALS/CHECKLIST	REPORTING FREQUENCY
REVEGETATION INSTALLATION	PROJECT BIOLOGIST WILL BE RESPONSIBLE FOR MONITORING/ LANDSCAPE CONTRACTOR WILL BE RESPONSIBLE FOR INSTALLATION AND MAINTENANCE.	AS NEEDED OR AT LEAST ONCE EVERY TWO WEEKS.	SITE OBSERVATION REPORTS (S.O.R.) PREPARED BY THE BIOLOGIST (BASED ON THE REVEGETATION PLAN CRITERIA)	AT SUCCESSFUL INSTALLATION (AS DETERMINED BY THE PROJECT BIOLOGIST)
120 DAY PEP	PROJECT BIOLOGIST WILL BE RESPONSIBLE FOR MONITORING/ LANDSCAPE CONTRACTOR WILL BE RESPONSIBLE FOR MAINTENANCE.	MONTHS 1 & 2 - BIWEEKLY, MONTHS 3 & 4 - AT LEAST ONCE A MONTH	S.O.R.'S PREPARED BY THE BIOLOGIST (BASED ON THE REVEGETATION PLAN CRITERIA)	AT THE END OF PEP**
25-MONTH LONG TERM MAINTENANCE & MONITORING	PROJECT BIOLOGIST WILL BE RESPONSIBLE FOR MONITORING/ LANDSCAPE CONTRACTOR WILL BE RESPONSIBLE FOR MAINTENANCE.	EVERY 3 MONTHS	S.O.R.'S PREPARED BY THE BIOLOGIST (BASED ON THE REVEGETATION PLAN CRITERIA)	EVERY 3 MONTHS YEAR 1** 25 MONTHS**

NOTE: IF 25 MONTH SUCCESS CRITERIA ARE NOT MET, THE M&M PROGRAM WILL BE EXTENDED AS REQUIRED, QUARTERLY MAINTENANCE AND MONITORING WITH YEARLY REPORTING SHALL CONTINUE AS NEEDED.
** PEP, 1 YEAR AND 25 MONTH FINAL REPORT(S) REQUIRED TO INCLUDE ABOVE INFORMATION.

SEWER GROUP JOB 691 (#WBS B-00446) REVEGETATION PLAN

Adam H. Behle
Adam Behle - Restoration Biologist

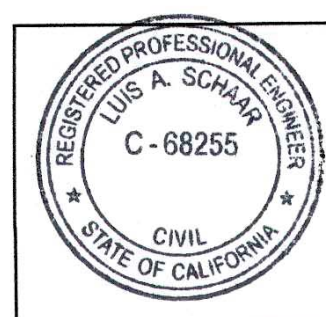

L-1

**SEWER GROUP 691
REVEGETATION SHEET**

CITY OF SAN DIEGO, CALIFORNIA PUBLIC WORKS DEPARTMENT SHEET 22 OF 22 SHEETS		WATER WBS - SEWER WBS B-00446
APPROVED: <i>[Signature]</i> FOR-CITY ENGINEER LUIS A. SCHAAR	DATE: 9/25/2014	DESIGNED BY: JERICHO GALLARDO PROJECT MANAGER
DESCRIPTION: ORIGINAL	BY: JG/JG	CHECKED BY: JOSE LITO GUINTO PROJECT ENGINEER
APPROVED: _____	DATE: _____	FILED: _____
CONTRACTOR INSPECTOR: _____	DATE STARTED: _____ DATE COMPLETED: _____	32506-22-D

NEW SHEET

City of San Diego

CONTRACTOR'S NAME: ORTIZ CORPORATION

ADDRESS: 2000 MCKINLEY AVENUE, NATIONAL CITY, CA 91950

TELEPHONE NO.: 619-434-7925 FAX NO.: 619-434-7931

CITY CONTACT: Damian Singleton - Contract Specialist, Email: Dsingleton@sandiego.gov

Phone No. (619) 533-3482, Fax No. (619) 533-3633

J. Gallardo / B. Doringo / ls

CONTRACT DOCUMENTS

FOR

SEWER GROUP 691

VOLUME 2 OF 2

BID NO.:	<u>K-15-5875-DBB-3-C</u>
SAP NO. (WBS/IO/CC):	<u>B-00446</u>
CLIENT DEPARTMENT:	<u>2011</u>
COUNCIL DISTRICT:	<u>3</u>
PROJECT TYPE:	<u>JA</u>

THIS CONTRACT IS SUBJECT TO THE FOLLOWING:

- PHASED-FUNDING.
- THE CITY'S SUBCONTRACTING PARTICIPATION REQUIREMENTS FOR SLBE PROGRAM.
- APPRENTICESHIP.



**THIS BIDDING DOCUMENT TO BE SUBMITTED IN ITS ENTIRETY
REFER TO VOLUME 1 COVER PAGE FOR TIME, DATE, AND LOCATION**

TABLE OF CONTENTS

DESCRIPTION

PAGE NUMBER

Volume 2 - Bidding Documents

The following forms must be completed in their entirety and submitted with the Bid. Include the form(s) even if the information does not apply. Where the information does not apply write in N/A. Failure to include any of the forms may cause the Bid to be deemed **non-responsive**. If you are uncertain or have any questions about any required information, contact the City no later than 14 days prior to Bid due date.

1. Bid/Proposal.....	3
2. Bid Bond	6
3. Non-Collusion Affidavit to be executed by Bidder and Submitted with Bid under 23 USC 112 and PCC 7106	7
4. Contractors Certification of Pending Actions	8
5. Equal Benefits Ordinance Certification of Compliance.....	9
6. Proposal (Bid)	10
7. Form AA35 - List of Subcontractors	16
8. Form AA40 - Named Equipment/Material Supplier List	17

BIDDING DOCUMENTS

PROPOSAL

Bidder's General Information

To the City of San Diego:

Pursuant to "Notice Inviting Bids", specifications, and requirements on file with the City Clerk, and subject to all provisions of the Charter and Ordinances of the City of San Diego and applicable laws and regulations of the United States and the State of California, the undersigned hereby proposes to furnish to the City of San Diego, complete at the prices stated herein, the items or services hereinafter mentioned. The undersigned further warrants that this bid is not made in the interest of, or on behalf of, any undisclosed person, partnership, company, association, organization, or corporation; that the bid is genuine and not collusive or sham; that the bidder has not directly or indirectly induced or solicited any other bidder to put in a false or sham bid, and has not directly or indirectly colluded, conspired, connived, or agreed with any bidder or anyone else to put in a sham bid, or that anyone shall refrain from bidding; that the bidder has not in any manner, directly or indirectly, sought by agreement, communication, or conference with anyone to fix the bid price of the bidder or any other bidder, or to fix any overhead, profit, or cost element of the bid price, or of that of any other bidder, or to secure any advantage against the public body awarding the contract of anyone interested in the proposed contract; that all statements contained in the bid are true; and, further, that the bidder has not, directly or indirectly, submitted his or her bid price or any breakdown thereof, or the contents thereof, or divulged information or data relative thereto, or paid, and will not pay, any fee to any corporation, partnership, company, association, organization, bid depository, or to any member or agent thereof to effectuate a collusive or sham bid.

The undersigned bidder(s) further warrants that bidder(s) has thoroughly examined and understands the entire Contract Documents (plans and specifications) and the Bidding Documents therefore, and that by submitting said Bidding Documents as its bid proposal, bidder(s) acknowledges and is bound by the entire Contract Documents, including any addenda issued thereto, as such Contract Documents incorporated by reference in the Bidding Documents.

IF A SOLE OWNER OR SOLE CONTRACTOR SIGN HERE:

- (1) Name under which business is conducted N/A
- (2) Signature (Given and surname) of proprietor _____
- (3) Place of Business (Street & Number) _____
- (4) City and State _____ Zip Code _____
- (5) Telephone No. _____ Facsimile No. _____
- (6) Email Address _____

IF A PARTNERSHIP, SIGN HERE:

- (1) Name under which business is conducted N/A

BIDDING DOCUMENTS

(2) Name of each member of partnership, indicate character of each partner, general or special (limited):

(3) Signature (Note: Signature must be made by a general partner)

Full Name and Character of partner

(4) Place of Business (Street & Number) _____

(5) City and State _____ Zip Code _____

(6) Telephone No. _____ Facsimile No. _____

(7) Email Address _____

IF A CORPORATION, SIGN HERE:

(1) Name under which business is conducted ORTIZ CORPORATION

(2) Signature, with official title of officer authorized to sign for the corporation:

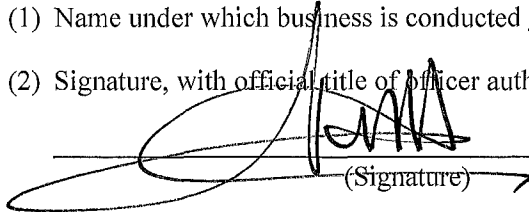

(Signature)

AIDA BANGHART
(Printed Name)

VICE PRESIDENT
(Title of Officer)

(Impress Corporate Seal Here)

(3) Incorporated under the laws of the State of CALIFORNIA

(4) Place of Business (Street & Number) 2000 MCKINLEY AVENUE

(5) City and State NATIONAL CITY Zip Code 91950

(6) Telephone No. 619-434-7925 Facsimile No. 619-434-7931

(7) Email Address LUCY@ORTIZCORPORATION.COM/JOSE@ORTIZCORPORATION.COM

BIDDING DOCUMENTS

THE FOLLOWING SECTIONS MUST BE FILLED IN BY ALL PROPOSERS:

In accordance with the "NOTICE INVITING BIDS", the bidder holds a California State Contractor's license for the following classification(s) to perform the work described in these specifications:

LICENSE CLASSIFICATION A

LICENSE NO. 602454 EXPIRES SEPTEMBER, 2014

This license classification must also be shown on the front of the bid envelope. Failure to show license classification on the bid envelope may cause return of the bid unopened.

TAX IDENTIFICATION NUMBER (TIN): [REDACTED]

Email Address: LUCY@ORTIZCORPORATION.COM/JOSE@ORTIZCORPORATION.COM

THIS PROPOSAL MUST BE NOTARIZED BELOW:

I certify, under penalty of perjury, that the representations made herein regarding my State Contractor's license number, classification and expiration date are true and correct.

Signature [Handwritten Signature] Title VICE PRESIDENT

SUBSCRIBED AND SWORN TO BEFORE ME, THIS 26TH DAY OF SEPTEMBER, 2014

Notary Public in and for the County of SAN DIEGO, State of CALIFORNIA

[Handwritten Signature]

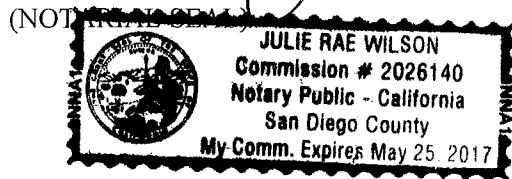

BIDDING DOCUMENTS

BID BOND

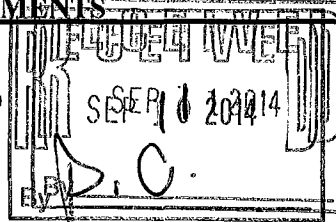

KNOW ALL MEN BY THESE PRESENTS,

That Ortiz Corporation as Principal, and International Fidelity Insurance Company as Surety, are held and firmly bound unto The City of San Diego hereinafter called "OWNER," in the sum of **10% OF THE TOTAL BID AMOUNT** for the payment of which sum, well and truly to be made, we bind ourselves, our heirs, executors, administrators, successors, and assigns, jointly and severally, firmly by these presents.

WHEREAS, said Principal has submitted a Bid to said OWNER to perform the WORK required under the bidding schedule(s) of the OWNER's Contract Documents entitled

Sewer Group 691

NOW THEREFORE, if said Principal is awarded a contract by said OWNER and, within the time and in the manner required in the "Notice Inviting Bids" enters into a written Agreement on the form of agreement bound with said Contract Documents, furnishes the required certificates of insurance, and furnishes the required Performance Bond and Payment Bond, then this obligation shall be null and void, otherwise it shall remain in full force and effect. In the event suit is brought upon this bond by said OWNER and OWNER prevails, said Surety shall pay all costs incurred by said OWNER in such suit, including a reasonable attorney's fee to be fixed by the court.

SIGNED AND SEALED, this 10th day of September, 2014

Ortiz Corporation (SEAL) International Fidelity Insurance Company(SEAL)
(Principal) (Surety)

By: Marcos E Ortiz
(Signature)

By: Bart Stewart
Bart Stewart, Attorney-in-Fact

(SEAL AND NOTARIAL ACKNOWLEDGEMENT OF SURETY)

POWER OF ATTORNEY

INTERNATIONAL FIDELITY INSURANCE COMPANY ALLEGHENY CASUALTY COMPANY

ONE NEWARK CENTER, 20TH FLOOR NEWARK, NEW JERSEY 07102-5207

KNOW ALL MEN BY THESE PRESENTS: That INTERNATIONAL FIDELITY INSURANCE COMPANY, a corporation organized and existing under the laws of the State of New Jersey, and ALLEGHENY CASUALTY COMPANY, a corporation organized and existing under the laws of the State of Pennsylvania, having their principal office in the City of Newark, New Jersey, do hereby constitute and appoint

BART STEWART

Encinitas, CA.

their true and lawful attorney(s)-in-fact to execute, seal and deliver for and on its behalf as surety, any and all bonds and undertakings, contracts of indemnity and other writings obligatory in the nature thereof, which are or may be allowed, required or permitted by law, statute, rule, regulation, contract or otherwise, and the execution of such instrument(s) in pursuance of these presents, shall be as binding upon the said INTERNATIONAL FIDELITY INSURANCE COMPANY and ALLEGHENY CASUALTY COMPANY, as fully and amply, to all intents and purposes, as if the same had been duly executed and acknowledged by their regularly elected officers at their principal offices.

This Power of Attorney is executed, and may be revoked, pursuant to and by authority of the By-Laws of INTERNATIONAL FIDELITY INSURANCE COMPANY and ALLEGHENY CASUALTY COMPANY and is granted under, and by authority of the following resolution adopted by the Board of Directors of INTERNATIONAL FIDELITY INSURANCE COMPANY at a meeting duly held on the 20th day of July, 2010 and by the Board of Directors of ALLEGHENY CASUALTY COMPANY at a meeting duly held on the 15th day of August, 2000:

"RESOLVED, that (1) the President, Vice President, or Secretary of the Corporation shall have the power to appoint, and to revoke the appointments of, Attorneys-in-Fact or agents with power and authority as defined or limited in their respective powers of attorney, and to execute on behalf of the Corporation and affix the Corporation's seal thereto, bonds, undertakings, recognizances, contracts of indemnity and other written obligations in the nature thereof or related thereto; and (2) any such Officers of the Corporation may appoint and revoke the appointments of joint-control custodians, agents for acceptance of process, and Attorneys-in-fact with authority to execute waivers and consents on behalf of the Corporation; and (3) the signature of any such Officer of the Corporation and the Corporation's seal may be affixed by facsimile to any power of attorney or certification given for the execution of any bond, undertaking, recognizance, contract of indemnity or other written obligation in the nature thereof or related thereto, such signature and seals when so used whether heretofore or hereafter, being hereby adopted by the Corporation as the original signature of such officer and the original seal of the Corporation, to be valid and binding upon the Corporation with the same force and effect as though manually affixed."

IN WITNESS WHEREOF, INTERNATIONAL FIDELITY INSURANCE COMPANY and ALLEGHENY CASUALTY COMPANY have each executed and attested these presents on this 12th day of March, 2012.

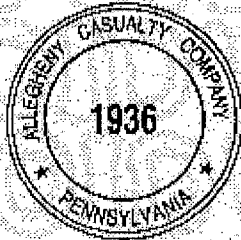

STATE OF NEW JERSEY
County of Essex

ROBERT W. MINSTER
Executive Vice President/Chief Operating Officer
(International Fidelity Insurance Company)
and President (Allegheny Casualty Company)

On this 12th day of March, 2012, before me came the individual who executed the preceding instrument, to me personally known, and, being by me duly sworn, said he is the therein described and authorized officer of INTERNATIONAL FIDELITY INSURANCE COMPANY and ALLEGHENY CASUALTY COMPANY; that the seals affixed to said instrument are the Corporate Seals of said Companies; that the said Corporate Seals and his signature were duly affixed by order of the Boards of Directors of said Companies.

IN TESTIMONY WHEREOF, I have hereunto set my hand affixed my Official Seal, at the City of Newark, New Jersey the day and year first above written.

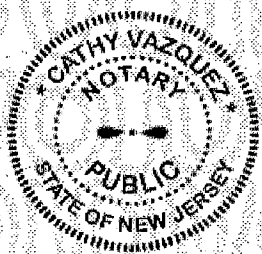

A NOTARY PUBLIC OF NEW JERSEY
My Commission Expires Mar. 27, 2014

CERTIFICATION

I, the undersigned officer of INTERNATIONAL FIDELITY INSURANCE COMPANY and ALLEGHENY CASUALTY COMPANY do hereby certify that I have compared the foregoing copy of the Power of Attorney and affidavit, and the copy of the Sections of the By-Laws of said Companies as set forth in said Power of Attorney, with the originals on file in the home office of said companies, and that the same are correct transcripts thereof, and of the whole of the said originals, and that the said Power of Attorney has not been revoked and is now in full force and effect.

IN TESTIMONY WHEREOF, I have hereunto set my hand this

10th day of September 2014

MARIA BRANCO, Assistant Secretary

CALIFORNIA ALL-PURPOSE CERTIFICATE OF ACKNOWLEDGMENT

State of California

County of San Diego

On 9/10/2014 before me, Brittany Aceves, Notary Public
(Here insert name and title of the officer)

personally appeared Bart Stewart

who proved to me on the basis of satisfactory evidence to be the person(s) whose name(s) is/are subscribed to the within instrument and acknowledged to me that he/she/they executed the same in his/her/their authorized capacity(ies), and that by his/her/their signature(s) on the instrument the person(s), or the entity upon behalf of which the person(s) acted, executed the instrument.

I certify under PENALTY OF PERJURY under the laws of the State of California that the foregoing paragraph is true and correct.

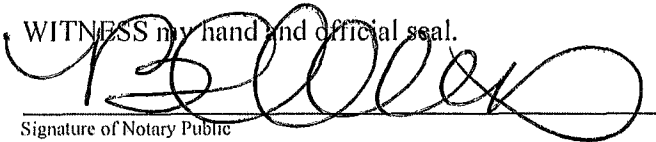
WITNESS my hand and official seal.

Signature of Notary Public



(Notary Seal)

ADDITIONAL OPTIONAL INFORMATION

DESCRIPTION OF THE ATTACHED DOCUMENT

(Title or description of attached document)

(Title or description of attached document continued)

Number of Pages _____ Document Date _____

(Additional information)

CAPACITY CLAIMED BY THE SIGNER

Individual (s)

Corporate Officer

(Title)

Partner(s)

Attorney-in-Fact

Trustee(s)

Other _____

INSTRUCTIONS FOR COMPLETING THIS FORM

Any acknowledgment completed in California must contain verbiage exactly as appears above in the notary section or a separate acknowledgment form must be properly completed and attached to that document. The only exception is if a document is to be recorded outside of California. In such instances, any alternative acknowledgment verbiage as may be printed on such a document so long as the verbiage does not require the notary to do something that is illegal for a notary in California (i.e. certifying the authorized capacity of the signer). Please check the document carefully for proper notarial wording and attach this form if required.

- State and County information must be the State and County where the document signer(s) personally appeared before the notary public for acknowledgment.
- Date of notarization must be the date that the signer(s) personally appeared which must also be the same date the acknowledgment is completed.
- The notary public must print his or her name as it appears within his or her commission followed by a comma and then your title (notary public).
- Print the name(s) of document signer(s) who personally appear at the time of notarization.
- Indicate the correct singular or plural forms by crossing off incorrect forms (i.e. he/she/they- is /are) or circling the correct forms. Failure to correctly indicate this information may lead to rejection of document recording.
- The notary seal impression must be clear and photographically reproducible. Impression must not cover text or lines. If seal impression smudges, re-seal if a sufficient area permits, otherwise complete a different acknowledgment form.
- Signature of the notary public must match the signature on file with the office of the county clerk.
 - ❖ Additional information is not required but could help to ensure this acknowledgment is not misused or attached to a different document.
 - ❖ Indicate title or type of attached document, number of pages and date.
 - ❖ Indicate the capacity claimed by the signer. If the claimed capacity is a corporate officer, indicate the title (i.e. CEO, CFO, Secretary).
- Securely attach this document to the signed document

BIDDING DOCUMENTS

CONTRACTORS CERTIFICATION OF PENDING ACTIONS

As part of its bid or proposal (Non-Price Proposal in the case of Design-Build contracts), the Bidder shall provide to the City a list of all instances within the past 10 years where a complaint was filed or pending against the Bidder in a legal or administrative proceeding alleging that Bidder discriminated against its employees, subcontractors, vendors or suppliers, and a description of the status or resolution of that complaint, including any remedial action taken.

CHECK ONE BOX ONLY.



The undersigned certifies that within the past 10 years the Bidder has NOT been the subject of a complaint or pending action in a legal administrative proceeding alleging that Bidder discriminated against its employees, subcontractors, vendors or suppliers.



The undersigned certifies that within the past 10 years the Bidder has been the subject of a complaint or pending action in a legal administrative proceeding alleging that Bidder discriminated against its employees, subcontractors, vendors or suppliers. A description of the status or resolution of that complaint, including any remedial action taken and the applicable dates is as follows:

DATE OF CLAIM	LOCATION	DESCRIPTION OF CLAIM	LITIGATION (Y/N)	STATUS	RESOLUTION/REMEDIAL ACTION TAKEN

Contractor Name: ORTIZ CORPORATION

Certified By AIDA BANGHART Name Title VICE PRESIDENT

 Signature Date 09/30/2014

USE ADDITIONAL FORMS AS NECESSARY

BIDDING DOCUMENTS

**EQUAL BENEFITS ORDINANCE
CERTIFICATION OF COMPLIANCE**



For additional information, contact:
CITY OF SAN DIEGO
EQUAL BENEFITS PROGRAM
 202 C Street, MS 9A, San Diego, CA 92101
 Phone (619) 533-3948 Fax (619) 533-3220

COMPANY INFORMATION

Company Name: ORTIZ CORPORATION	Contact Name: LUCY ORTIZ
Company Address: 2000 MC KINLEY AVENUE	Contact Phone: 619-434-7925
NATIONAL CITY, CA 91950	Contact Email: LUCY@ORTIZCORPORATION.COM

CONTRACT INFORMATION

Contract Title: SEWER GROUP 691	Start Date: DEC 2014
Contract Number (if no number, state location): K-15-5875-DBB-3-C	End Date: JUN 2015

SUMMARY OF EQUAL BENEFITS ORDINANCE REQUIREMENTS

The Equal Benefits Ordinance [EBO] requires the City to enter into contracts only with contractors who certify they will provide and maintain equal benefits as defined in SDMC §22.4302 for the duration of the contract. To comply:

- Contractor shall offer equal benefits to employees with spouses and employees with domestic partners.
 - Benefits include health, dental, vision insurance; pension/401(k) plans; bereavement, family, parental leave; discounts, child care; travel/relocation expenses; employee assistance programs; credit union membership; or any other benefit.
 - Any benefit not offer an employee with a spouse, is not required to be offered to an employee with a domestic partner.
- Contractor shall post notice of firm's equal benefits policy in the workplace and notify employees at time of hire and during open enrollment periods.
- Contractor shall allow City access to records, when requested, to confirm compliance with EBO requirements.
- Contractor shall submit *EBO Certification of Compliance*, signed under penalty of perjury, prior to award of contract.

NOTE: This summary is provided for convenience. Full text of the EBO and Rules Implementing the EBO are available at www.sandiego.gov/administration.

CONTRACTOR EQUAL BENEFITS ORDINANCE CERTIFICATION

Please indicate your firm's compliance status with the EBO. The City may request supporting documentation.



I affirm **compliance** with the EBO because my firm (*contractor must select one reason*):

- Provides equal benefits to spouses and domestic partners.
 - Provides no benefits to spouses or domestic partners.
 - Has no employees.
 - Has collective bargaining agreement(s) in place prior to January 1, 2011, that has not been renewed or expired.



I request the City's approval to pay affected employees a cash equivalent in lieu of equal benefits and verify my firm made a reasonable effort but is not able to provide equal benefits upon contract award. I agree to notify employees of the availability of a cash equivalent for benefits available to spouses but not domestic partners and to continue to make every reasonable effort to extend all available benefits to domestic partners.

It is unlawful for any contractor to knowingly submit any false information to the City regarding equal benefits or cash equivalent associated with the execution, award, amendment, or administration of any contract. [San Diego Municipal Code §22.4307(a)]

Under penalty of perjury under laws of the State of California, I certify the above information is true and correct. I further certify that my firm understands the requirements of the Equal Benefits Ordinance and will provide and maintain equal benefits for the duration of the contract or pay a cash equivalent if authorized by the City.

VICE PRESIDENT

Name/Title of Signatory

Signature

09/30/14

Date

FOR OFFICIAL CITY USE ONLY

Receipt Date: _____ EBO Analyst: _____ Approved Not Approved – Reason: _____

(Rev 02/15/2011)

BIDDING DOCUMENTS

PROPOSAL (BID)

The Bidder agrees to the construction of **Sewer Group 691**, for the City of San Diego, in accordance with these contract documents for the prices listed below. The Bidder guarantees the Contract Price for a period of 120 days (90 days for federally funded contracts and contracts valued at \$500,000 or less) from the date of Bid opening to Award of the Contract. The duration of the Contract Price guarantee shall be extended by the number of days required for the City to obtain all items necessary to fulfill all conditions precedent e.g., bond and insurance.

Item	Quantity	Unit	NAICS	Payment Reference	Description	Unit Price	Extension
BASE BID							
1	1	LS	524126	2-4.1	Bonds (Payment and Performance)	 	\$ 19,000.00
2	1	LS	238990	7-9.1.1	Video Recording of Pre-existing Conditions	 	\$ 14,755.00
3	1	LS	237310	7-10.2.6	Traffic Control	 	\$ 35,000.00
4	1	LS	237110	9-3.4.1	Mobilization	 	\$ 40,000.00
5	1	AL		9-3.5	Field Orders - Type II	 	\$121,500.00
6	335	LF	238910	300-1.4	Removal and Disposal of Railroad Tracks	\$ 40.00	\$ 13,400.00
7	16	CY	237310	300-1.4	Additional Pavement Removal & Disposal	\$ 50.00	\$ 800.00
8	21	TON	237310	302-3.4	Asphalt Pavement Repair	\$ 500.00	\$ 10,500.00
9	63,000	SF	237310	302-4.12.4	Rubber Polymer Modified Slurry Type II and Striping	\$ 0.44	\$ 27,720.00
10	3,500	SF	237310	302-5.2.1	Pavement Restoration Adjacent to Trench	\$ 9.00	\$ 31,500.00
11	28,000	SF	237310	302-6.8	Concrete Pavement	\$ 9.00	\$ 252,000.00
12	4	EA	237110	303-1.11	Cutoff Wall	\$ 4,400.00	\$ 17,600.00
13	1	EA	237111	303-1.11	Concrete Anchor	\$ 6,000.00	\$ 6,000.00

BIDDING DOCUMENTS

Item	Quantity	Unit	NAICS	Payment Reference	Description	Unit Price	Extension
14	6	EA	237310	303-5.9	Contractor Date Stamp and Impressions	\$ 250.00	\$ 1,500.00
15	95	LF	237310	303-5.9	Additional Curb and Gutter	\$ 35.00	\$ 3,325.00
16	400	SF	237310	303-5.9	Additional Sidewalk Removal and Replacement	\$ 10.00	\$ 4,000.00
17	9	EA	237310	303-5.10.2	Curb Ramp Type A with Detectable Warning Tiles	\$ 2,500.00	\$ 22,500.00
18	1	EA	237310	303-5.10.2	Curb Ramp Type A with Stainless Steel Detectable Warning Tiles	\$ 2,700.00	\$ 2,700.00
19	1	EA	237310	303-5.10.2	Curb Ramp Type B with Detectable Warning Tiles	\$ 2,500.00	\$ 2,500.00
20	7	EA	237310	303-5.10.2	Curb Ramp Type D with Detectable Warning Tiles	\$ 2,150.00	\$ 15,050.00
21	1	LS	237110	306-1.1.6	Trench Shoring	\$ 12,000.00	\$ 12,000.00
22	98	CY	237110	306-1.2.1.1	Additional Bedding	\$ 35.00	\$ 3,430.00
23	270	TON	237310	306-1.5.1	Temporary Resurfacing	\$ 130.00	\$ 35,100.00
24	1,200	TON	237110	306-1.6	Imported Backfill	\$ 40.00	\$ 48,000.00
25	3,466	LF	237110	306-1.6	8-Inch Sewer Main	\$ 94.00	\$ 325,804.00
26	451	LF	237110	306-1.6	8-Inch Sewer Main, Special Strength SDR-26	\$ 125.00	\$ 56,375.00
27	17	EA	237110	306-1.8.6	Manholes (4 x 3)	\$ 3,600.00	\$ 61,200.00
28	8	EA	237110	306-1.8.6	Manholes (4 x 3), with Locking Device	\$ 4,250.00	\$ 34,000.00
29	4	EA	237110	306-1.8.6	Connection to Existing Manhole and Rechanneling	\$ 2,100.00	\$ 8,400.00
30	35	EA	237110	306-1.9.1	4-Inch Sewer Lateral & Cleanout (Street)	\$ 1,900.00	\$ 66,500.00
31	61	EA	237110	306-1.9.1	4-Inch Sewer Lateral & Cleanout (Alley)	\$ 1,300.00	\$ 79,300.00

BIDDING DOCUMENTS

Item	Quantity	Unit	NAICS	Payment Reference	Description	Unit Price	Extension
32	1	EA	231110	306-1.9.1	Sewer Lateral Connection	\$ 3,900.00	\$ 3,900.00
33	17	EA	237110	306-1.9.2.5	4-Inch Sewer Lateral with Private Replumbing	\$ 11,000.00	\$ 187,000.00
34	5	EA	237110	306-1.9.2.5	6-Inch Sewer Lateral with Private Replumbing	\$ 12,000.00	\$ 60,000.00
35	3	EA	237110	306-1.9.2.5	4-Inch Trenchless Method for Private Replumbing	\$ 16,000.00	\$ 48,000.00
36	1	EA	237110	306-1.9.2.5	6-Inch Trenchless Method for Private Replumbing	\$ 17,000.00	\$ 17,000.00
37	10	EA	237110	306-1.9.3.7	Private Pump System	\$ 29,610.20	\$ 296,102.00
38	3	EA	237110	306-1.9.3.7	Trenchless Method for Private Pump System	\$ 8,900.00	\$ 26,700.00
39	10	EA	237110	306-1.9.3.7	Extended Warranty for Private Pumps	\$ 1,500.00	\$ 15,000.00
40	10	EA	237110	306-1.9.3.7	Pump Compensation	\$ 6,384.00	\$ 63,840.00
41	7	EA	237110	306-5.3	Abandon Existing Manhole Outside of Trench	\$ 1,500.00	\$ 10,500.00
42	2,608	LF	237110	306-5.3	Abandon and Fill Existing 6-Inch Sewer Main Outside of Trench Limit	\$ 5.00	\$ 13,040.00
43	326	LF	237110	306-5.3	Abandon and Fill Existing 8-Inch Sewer Main Outside of Trench Limit	\$ 10.00	\$ 3,260.00
44	4,373	LF	237110	306-9.7	Video Inspecting Pipelines for Acceptance	\$ 0.60	\$ 2,623.80
45	3,316	LF	237110	306-9.7	Cleaning and Video Inspecting Pipelines	\$ 1.50	\$ 4,974.00
46	62	LF	237110	306-21.9	Pipe Bursting	\$ 270.00	\$ 16,740.00
47	161	LF	237110	500-1.1.9	Rehabilitate 6-Inch Sewer Main	\$ 76.65	\$ 12,340.65
48	220	LF	237110	500-1.1.9	Rehabilitate 8-Inch Sewer Main	\$ 67.20	\$ 14,784.00

BIDDING DOCUMENTS

Item	Quantity	Unit	NAICS	Payment Reference	Description	Unit Price	Extension
49	1	EA	237110	500-4.9	Service Lateral Connection	\$ 2,310.00	\$ 2,310.00
50	3	EA	237110	500-2.10.2	Rehabilitate Existing Manhole	\$ 2,950.00	\$ 8,850.00
51	1	LS	238390	700-2.15	Clearing and Grubbing	 	\$ 29,500.00
52	1	LS	237990	700-2.15	Construction Fencing and Access Route	 	\$ 25,000.00
53	1	LS	561730	700-2.15	Revegetation and Erosion Control	 	\$ 33,720.75
54	1	LS	541330	700-2.15	Revegetation Maintenance and Monitoring Program	 	\$ 51,513.84
55	1	LS	541330	701-13.9.5	Water Pollution Control Program Development	 	\$ 600.00
56	1	LS	237990	701-13.9.5	Water Pollution Control Program Implementation	 	\$ 4,500.00
57	1	LS	237110	704-4	Sewage Bypass and Pumping Plan (Diversion Plan)	 	\$ 4,000.00
58	5	DAYS	541330	707-1	Suspension of Work - Resources	\$ 600.00	\$ 3,000.00
59	2,853	LF	541330	707-2	Archeological and Native American Monitoring Program	\$ 10.00	\$ 28,530.00
60	899	LF	541330	707-3	Paleontological Monitoring Program	\$ 5.00	\$ 4,495.00
61	1	AL	541330	707-4	Archeological and Native American Mitigation and Curation - Type I	 	\$20,000.00
62	850	CY	541330	707-5	Paleontological Mitigation and Excavation	\$ 8.00	\$ 6,800.00
ESTIMATED TOTAL BASE BID:							\$ 2,390,083.04

TOTAL BID PRICE FOR BID (Items 1 through 62 inclusive) amount written in words:

TWO MILLION, THREE HUNDRED NINETY THOUSAND, EIGHTY THREE DOLLARS & FOUR CENTS*****

BIDDING DOCUMENTS

The Bid shall contain an acknowledgment of receipt of all addenda, the numbers of which shall be filled in on the Bid form. If an addendum or addenda has been issued by the City and not noted as being received by the Bidder, this proposal shall be rejected as being **non-responsive**. The following addenda have been received and are acknowledged in this bid: A

The names of all persons interested in the foregoing proposal as principals are as follows:

MARCELINO E. ORTIZ - PRESIDENT

AIDA BANGHART - VICE PRESIDENT

TERESA O. ORTIZ - SECRETARY

IMPORTANT NOTICE: If Bidder or other interested person is a corporation, state secretary, treasurer, and manager thereof; if a co-partnership, state true name of firm, also names of all individual co-partners composing firm; if Bidder or other interested person is an individual, state first and last names in full.

Bidder: AIDA BANGHART for ORTIZ CORPORATION

Title: VICE PRESIDENT

Business Address: 2000 MCKINLEY AVENUE

Place of Business: NATIONAL CITY, CA 91950

Place of Residence: 4805 BRAM AVENUE, BONITA, A 91902

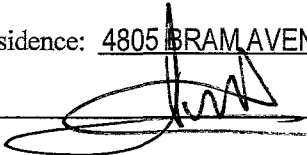
Signature: 

BIDDING DOCUMENTS

NOTES:

- A. The City shall determine the low Bid based on the Base Bid alone.
- B. Prices and notations shall be in ink or typewritten. All corrections (which have been initiated by the Bidder using erasures, strike out, line out, or "white-out") shall be typed or written in with ink adjacent thereto, and shall be initialed in ink by the person signing the bid proposal.
- C. Failure to initial all corrections made in the bidding documents shall cause the Bid to be rejected as **non-responsive** and ineligible for further consideration.
- D. Blank spaces must be filled in, using figures. Bidder's failure to submit a price for any Bid item that requires the Bidder to submit a price shall render the Bid **non-responsive** and shall be cause for its rejection.
- E. Unit prices shall be entered for all unit price items. Unit prices shall not exceed two (2) decimal places. If the Unit prices entered exceed two (2) decimal places, the City will only use the first two digits after the decimal points without rounding up or down.
- F. All extensions of the unit prices bid will be subject to verification by the City. In the case of inconsistency or conflict between the product of the Quantity x Unit Price and the Extension, the product shall govern.
- G. In the case of inconsistency or conflict, between the sums of the Extensions with the estimated total Bid, the sum of the Extensions shall govern.
- H. Bids shall not contain any recapitulation of the Work. Conditional Bids will be rejected as being **non-responsive**. Alternative proposals will not be considered unless called for.
- I. Subcontractors' License Number must be filled in. Failure to provide the information specified may deem the bidder **non-responsive**.

BIDDING DOCUMENTS

LIST OF SUBCONTRACTORS

In accordance with the requirements provided in the "Subletting and Subcontracting Fair Practices Act", Division 2, Part 1, Chapter 4 of the Public Contract Code, the Bidder shall list below the name and address of each Subcontractor who will perform work, labor, render services or specially fabricates and installs a portion [type] of the work or improvement, in an amount in excess of 0.5% of the Contractor's total Bid. The Bidder shall also list below the portion of the work which will be done by each subcontractor under this Contract. The Contractor shall list only one Subcontractor for each portion of the Work. The **DOLLAR VALUE** of the total Bid to be performed shall be stated for all subcontractors listed. Failure to comply with this requirement shall result in the Bid being rejected as **non-responsive** and ineligible for award. The Bidder's attention is directed to the Special Provisions - General; Paragraph 2-3 Subcontracts, which stipulates the percent of the Work to be performed with the Bidders' own forces. The Bidder shall list all SLBE, ELBE, DBE, DVBE, MBE, WBE, OBE, SDB, WoSB, HUBZone, and SDVOSB Subcontractors that Bidders are seeking recognition towards achieving any mandatory, voluntary, or both subcontracting participation percentages.

Subcontractors' License Number must be filled in. Failure to provide the information specified may deem the bidder **non-responsive**.

NAME, ADDRESS AND TELEPHONE NUMBER OF SUBCONTRACTOR	CONSTRUCTOR OR DESIGNER	SUBCONTRACTOR LICENSE NUMBER	TYPE OF WORK	DOLLAR VALUE OF SUBCONTRACT (MUST BE FILLED OUT)	MBE, WBE, DBE, DVBE, OBE, ELBE, SLBE, SDB, WoSB, HUBZone, OR SDVOSB	WHERE CERTIFIED ②	CHECK IF JOINT VENTURE PARTNERSHIP
Name: VIDEO FACT DOCUMENTATION Address: 4609 LYONS DR. City: LA MESA State: CA Zip: 91941 Phone: 619-442-0080 Email: CHRIS@VIDEOFACT.NET	CONSTRUCTION SERVICES	11RC0404	PRECON VIDEO	\$1,880.00	ELBE	CITY OF SAN DIEGO	N/A
Name: HUDSON SAFE-T-LITE RENTALS Address: 777 GABLE WAY City: EL CAJON State: CA Zip: 92022 Phone: 619-441-3644 Email: WWW.HUDSONSAFETLITE.COM	CONSTRUCTOR SERVICES	788289	TRAFFIC CONTROL DESIGN	\$2,100.00	SLBE	CITY OF SAN DIEGO	N/A

① As appropriate, Bidder shall identify Subcontractor as one of the following and shall include a valid proof of certification (except for OBE, SLBE and ELBE):

- | | | | |
|---|--------|--|---------|
| Certified Minority Business Enterprise | MBE | Certified Woman Business Enterprise | WBE |
| Certified Disadvantaged Business Enterprise | DBE | Certified Disabled Veteran Business Enterprise | DVBE |
| Other Business Enterprise | OBE | Certified Emerging Local Business Enterprise | ELBE |
| Certified Small Local Business Enterprise | SLBE | Small Disadvantaged Business | SDB |
| Woman-Owned Small Business | WoSB | HUBZone Business | HUBZone |
| Service-Disabled Veteran Owned Small Business | SDVOSB | | |

② As appropriate, Bidder shall indicate if Subcontractor is certified by:

- | | | | |
|--|--------|--|----------|
| City of San Diego | CITY | State of California Department of Transportation | CALTRANS |
| California Public Utilities Commission | CPUC | San Diego Regional Minority Supplier Diversity Council | SRMSDC |
| State of California's Department of General Services | CADoGS | City of Los Angeles | LA |
| State of California | CA | U.S. Small Business Administration | SBA |

The Bidder will not receive any subcontracting participation percentages if the Bidder fails to submit the required proof of certification.

Handwritten signature/initials: 24-15

BIDDING DOCUMENTS

LIST OF SUBCONTRACTORS

In accordance with the requirements provided in the "Subletting and Subcontracting Fair Practices Act", Division 2, Part 1, Chapter 4 of the Public Contract Code, the Bidder shall list below the name and address of each Subcontractor who will perform work, labor, render services or specially fabricates and installs a portion [type] of the work or improvement, in an amount in excess of 0.5% of the Contractor's total Bid. The Bidder shall also list below the portion of the work which will be done by each subcontractor under this Contract. The Contractor shall list only one Subcontractor for each portion of the Work. The **DOLLAR VALUE** of the total Bid to be performed shall be stated for all subcontractors listed. Failure to comply with this requirement shall result in the Bid being rejected as **non-responsive** and ineligible for award. The Bidder's attention is directed to the Special Provisions - General; Paragraph 2-3 Subcontracts, which stipulates the percent of the Work to be performed with the Bidders' own forces. The Bidder shall list all SLBE, ELBE, DBE, DVBE, MBE, WBE, OBE, SDB, WoSB, HUBZone, and SDVOSB Subcontractors that Bidders are seeking recognition towards achieving any mandatory, voluntary, or both subcontracting participation percentages.

Subcontractors' License Number must be filled in. Failure to provide the information specified may deem the bidder **non-responsive**.

NAME, ADDRESS AND TELEPHONE NUMBER OF SUBCONTRACTOR	CONSTRUCTOR OR DESIGNER	SUBCONTRACTOR LICENSE NUMBER	TYPE OF WORK	DOLLAR VALUE OF SUBCONTRACT (MUST BE FILLED OUT)	MBE, WBE, DBE, DVBE, OBE, ELBE, SLBE, SDB, WoSB, HUBZone, OR SDVOSB	WHERE CERTIFIED ②	CHECK IF JOINT VENTURE PARTNERSHIP
Name: <u>SEAL RIGHT PAVING</u> Address: <u>P.O.BOX 2753</u> City: <u>SPRING VALLEY</u> State: <u>CA</u> Zip: <u>91979</u> Phone: <u>619-465-7411</u> Email: <u>SRPESTIMATING@SBCGLOBAL.NET</u>	CONSTRUCTOR	364113	ASPHALT PAVING	\$78,845.10	SLBE	CITY OF SAN DIEGO	N/A
Name: <u>YBS CONCRETE, INC.</u> Address: <u>821 KUHN DR. #204</u> City: <u>CHULA VISTA</u> State: <u>CA</u> Zip: <u>91914</u> Phone: <u>619-721-6122</u> Email: <u>YBSCONCRETE@YAHOO.COM</u>	CONSTRUCTOR	237310	CURB RAMPS	\$288,725.00	ELBE	CITY OF SAN DIEGO	N/A

① As appropriate, Bidder shall identify Subcontractor as one of the following and shall include a valid proof of certification (except for OBE, SLBE and ELBE):

- | | | | |
|---|--------|--|---------|
| Certified Minority Business Enterprise | MBE | Certified Woman Business Enterprise | WBE |
| Certified Disadvantaged Business Enterprise | DBE | Certified Disabled Veteran Business Enterprise | DVBE |
| Other Business Enterprise | OBE | Certified Emerging Local Business Enterprise | ELBE |
| Certified Small Local Business Enterprise | SLBE | Small Disadvantaged Business | SDB |
| Woman-Owned Small Business | WoSB | HUBZone Business | HUBZone |
| Service-Disabled Veteran Owned Small Business | SDVOSB | | |

② As appropriate, Bidder shall indicate if Subcontractor is certified by:

- | | | | |
|--|--------|--|----------|
| City of San Diego | CITY | State of California Department of Transportation | CALTRANS |
| California Public Utilities Commission | CPUC | San Diego Regional Minority Supplier Diversity Council | SRMSDC |
| State of California's Department of General Services | CADoGS | City of Los Angeles | LA |
| State of California | CA | U.S. Small Business Administration | SBA |

The Bidder will not receive any subcontracting participation percentages if the Bidder fails to submit the required proof of certification.

BIDDING DOCUMENTS

LIST OF SUBCONTRACTORS

In accordance with the requirements provided in the "Subletting and Subcontracting Fair Practices Act", Division 2, Part 1, Chapter 4 of the Public Contract Code, the Bidder shall list below the name and address of each Subcontractor who will perform work, labor, render services or specially fabricates and installs a portion [type] of the work or improvement, in an amount in excess of 0.5% of the Contractor's total Bid. The Bidder shall also list below the portion of the work which will be done by each subcontractor under this Contract. The Contractor shall list only one Subcontractor for each portion of the Work. The **DOLLAR VALUE** of the total Bid to be performed shall be stated for all subcontractors listed. Failure to comply with this requirement shall result in the Bid being rejected as **non-responsive** and ineligible for award. The Bidder's attention is directed to the Special Provisions - General; Paragraph 2-3 Subcontracts, which stipulates the percent of the Work to be performed with the Bidders' own forces. The Bidder shall list all SLBE, ELBE, DBE, DVBE, MBE, WBE, OBE, SDB, WoSB, HUBZone, and SDVOSB Subcontractors that Bidders are seeking recognition towards achieving any mandatory, voluntary, or both subcontracting participation percentages.

Subcontractors' License Number must be filled in. Failure to provide the information specified may deem the bidder **non-responsive**.

NAME, ADDRESS AND TELEPHONE NUMBER OF SUBCONTRACTOR	CONSTRUCTOR OR DESIGNER	SUBCONTRACTOR LICENSE NUMBER	TYPE OF WORK	DOLLAR VALUE OF SUBCONTRACT (MUST BE FILLED OUT)	MBE, WBE, DBE, DVBE, OBE, ELBE, SLBE, SDB, WoSB, HUBZone, OR SDVOSB	WHERE CERTIFIED ②	CHECK IF JOINT VENTURE PARTNERSHIP
Name: <u>MCGRATH CONSULTING</u> Address: <u>POBOX 2488</u> City: <u>EL CAJON</u> State: <u>CA</u> Zip: <u>92021</u> Phone: <u>619-443-3811</u> Email: <u>WWW.MCSWPPP.COM</u>	CONSTRUCTION SERVICE	N/A	WATER POLLUTION CONTROL PLAN	\$595.00	ELBE	CITY OF SAN DIEGO	N/A
Name: <u>AMERICAN ASPHALT</u> Address: <u>POBOX 310036</u> City: <u>FONTANA</u> State: <u>CA</u> Zip: <u>92331</u> Phone: <u>909-427-8276</u> Email: <u>WWW.AMERICANASPHALT.COM</u>	CONSTRUCTOR	751836	SLURRY SEAL	\$22,750.00	OBE	N/A	N/A

① As appropriate, Bidder shall identify Subcontractor as one of the following and shall include a valid proof of certification (except for OBE, SLBE and ELBE):

- | | | | |
|---|--------|--|---------|
| Certified Minority Business Enterprise | MBE | Certified Woman Business Enterprise | WBE |
| Certified Disadvantaged Business Enterprise | DBE | Certified Disabled Veteran Business Enterprise | DVBE |
| Other Business Enterprise | OBE | Certified Emerging Local Business Enterprise | ELBE |
| Certified Small Local Business Enterprise | SLBE | Small Disadvantaged Business | SDB |
| Woman-Owned Small Business | WoSB | HUBZone Business | HUBZone |
| Service-Disabled Veteran Owned Small Business | SDVOSB | | |

② As appropriate, Bidder shall indicate if Subcontractor is certified by:

- | | | | |
|--|--------|--|----------|
| City of San Diego | CITY | State of California Department of Transportation | CALTRANS |
| California Public Utilities Commission | CPUC | San Diego Regional Minority Supplier Diversity Council | SRMSDC |
| State of California's Department of General Services | CADoGS | City of Los Angeles | LA |
| State of California | CA | U.S. Small Business Administration | SBA |

The Bidder will not receive any subcontracting participation percentages if the Bidder fails to submit the required proof of certification.

BIDDING DOCUMENTS

LIST OF SUBCONTRACTORS

In accordance with the requirements provided in the "Subletting and Subcontracting Fair Practices Act", Division 2, Part 1, Chapter 4 of the Public Contract Code, the Bidder shall list below the name and address of each Subcontractor who will perform work, labor, render services or specially fabricates and installs a portion [type] of the work or improvement, in an amount in excess of 0.5% of the Contractor's total Bid. The Bidder shall also list below the portion of the work which will be done by each subcontractor under this Contract. The Contractor shall list only one Subcontractor for each portion of the Work. The **DOLLAR VALUE** of the total Bid to be performed shall be stated for all subcontractors listed. Failure to comply with this requirement shall result in the Bid being rejected as **non-responsive** and ineligible for award. The Bidder's attention is directed to the Special Provisions - General; Paragraph 2-3 Subcontracts, which stipulates the percent of the Work to be performed with the Bidders' own forces. The Bidder shall list all SLBE, ELBE, DBE, DVBE, MBE, WBE, OBE, SDB, WoSB, HUBZone, and SDVOSB Subcontractors that Bidders are seeking recognition towards achieving any mandatory, voluntary, or both subcontracting participation percentages.

Subcontractors' License Number must be filled in. Failure to provide the information specified may deem the bidder **non-responsive**.

NAME, ADDRESS AND TELEPHONE NUMBER OF SUBCONTRACTOR	CONSTRUCTOR OR DESIGNER	SUBCONTRACTOR LICENSE NUMBER	TYPE OF WORK	DOLLAR VALUE OF SUBCONTRACT (MUST BE FILLED OUT)	MBE, WBE, DBE, DVBE, OBE, ELBE, SLBE, SDB, WoSB, HUBZone, OR SDVOSB	WHERE CERTIFIED ②	CHECK IF JOINT VENTURE PARTNERSHIP
Name: <u>BRIAN F. SMITH AND ASSOCIATES</u> Address: <u>14010 POWAY RD. SUITE A</u> City: <u>POWAY</u> State: <u>CA</u> Zip: <u>92064</u> Phone: <u>858-679-8218</u> Email: <u>KGUERRERO@BFSA-CA.COM</u>	CONSTRUCTION SERVICES	B1986004315	ENVIRONGM ENTAL SERVICES	\$56,837.00	SLBE	CITY OF SAN DIEGO	N/A
Name: <u>SOUTHWEST PIPELINE</u> Address: <u>22118 SOUTH VERMONT AVE.</u> City: <u>TORRANCE</u> State: <u>CA</u> Zip: <u>90502</u> Phone: <u>310-329-8717</u> Email: <u>WWW.SWPIPELINE.COM</u>	CONSTRUCTOR	773862-A	SEWER MAIN REHAB/ TOP HAT	\$28,033.00	OBE	N/A	N/A

① As appropriate, Bidder shall identify Subcontractor as one of the following and shall include a valid proof of certification (except for OBE, SLBE and ELBE):

- | | | | |
|---|--------|--|---------|
| Certified Minority Business Enterprise | MBE | Certified Woman Business Enterprise | WBE |
| Certified Disadvantaged Business Enterprise | DBE | Certified Disabled Veteran Business Enterprise | DVBE |
| Other Business Enterprise | OBE | Certified Emerging Local Business Enterprise | ELBE |
| Certified Small Local Business Enterprise | SLBE | Small Disadvantaged Business | SDB |
| Woman-Owned Small Business | WoSB | HUBZone Business | HUBZone |
| Service-Disabled Veteran Owned Small Business | SDVOSB | | |

② As appropriate, Bidder shall indicate if Subcontractor is certified by:

- | | | | |
|--|--------|--|----------|
| City of San Diego | CITY | State of California Department of Transportation | CALTRANS |
| California Public Utilities Commission | CPUC | San Diego Regional Minority Supplier Diversity Council | SRMSDC |
| State of California's Department of General Services | CADoGS | City of Los Angeles | LA |
| State of California | CA | U.S. Small Business Administration | SBA |

The Bidder will not receive any subcontracting participation percentages if the Bidder fails to submit the required proof of certification.

BIDDING DOCUMENTS

LIST OF SUBCONTRACTORS

In accordance with the requirements provided in the "Subletting and Subcontracting Fair Practices Act", Division 2, Part 1, Chapter 4 of the Public Contract Code, the Bidder shall list below the name and address of each Subcontractor who will perform work, labor, render services or specially fabricates and installs a portion [type] of the work or improvement, in an amount in excess of 0.5% of the Contractor's total Bid. The Bidder shall also list below the portion of the work which will be done by each subcontractor under this Contract. The Contractor shall list only one Subcontractor for each portion of the Work. The **DOLLAR VALUE** of the total Bid to be performed shall be stated for all subcontractors listed. Failure to comply with this requirement shall result in the Bid being rejected as **non-responsive** and ineligible for award. The Bidder's attention is directed to the Special Provisions - General; Paragraph 2-3 Subcontracts, which stipulates the percent of the Work to be performed with the Bidders' own forces. The Bidder shall list all SLBE, ELBE, DBE, DVBE, MBE, WBE, OBE, SDB, WoSB, HUBZone, and SDVOSB Subcontractors that Bidders are seeking recognition towards achieving any mandatory, voluntary, or both subcontracting participation percentages.

Subcontractors' License Number must be filled in. Failure to provide the information specified may deem the bidder **non-responsive**.

NAME, ADDRESS AND TELEPHONE NUMBER OF SUBCONTRACTOR	CONSTRUCTOR OR DESIGNER	SUBCONTRACTOR LICENSE NUMBER	TYPE OF WORK	DOLLAR VALUE OF SUBCONTRACT (MUST BE FILLED OUT)	MBE, WBE, DBE, DVBE, OBE, ELBE, SLBE, SDB, WoSB, HUBZone, OR SDVOSB	WHERE CERTIFIED Ⓢ	CHECK IF JOINT VENTURE PARTNERSHIP
Name: <u>PAYCO SPECIALTIES INC.</u> Address: <u>120 N SECOND AVE</u> City: <u>CHULA VISTA</u> State: <u>CA</u> Zip: <u>91910</u> Phone: <u>619-427-1620</u> Email: <u>WWW.PAYCO.BIZ</u>	CONSTRUCTOR	298637	STRIPING	\$4,585.00	SLBE	CITY OF SAN DIEGO	N/A
Name: <u>COASTAL PIPELINE SERVICES</u> Address: <u>POBOX 235653</u> City: <u>ENCINITAS</u> State: <u>CA</u> Zip: <u>92023</u> Phone: <u>760-828-5174</u> Email: <u>DREADUDE@SBCGLOBAL.NET</u>	CONSTRUCTOR SERVICES	878225	TELEVISIONING	\$6,821.65	ELBE	CITY OF SAN DIEGO	N/A

① As appropriate, Bidder shall identify Subcontractor as one of the following and shall include a valid proof of certification (except for OBE, SLBE and ELBE):

Certified Minority Business Enterprise	MBE	Certified Woman Business Enterprise	WBE
Certified Disadvantaged Business Enterprise	DBE	Certified Disabled Veteran Business Enterprise	DVBE
Other Business Enterprise	OBE	Certified Emerging Local Business Enterprise	ELBE
Certified Small Local Business Enterprise	SLBE	Small Disadvantaged Business	SDB
Woman-Owned Small Business	WoSB	HUBZone Business	HUBZone
Service-Disabled Veteran Owned Small Business	SDVOSB		

Ⓢ As appropriate, Bidder shall indicate if Subcontractor is certified by:

City of San Diego	CITY	State of California Department of Transportation	CALTRANS
California Public Utilities Commission	CPUC	San Diego Regional Minority Supplier Diversity Council	SRMSDC
State of California's Department of General Services	CADoGS	City of Los Angeles	LA
State of California	CA	U.S. Small Business Administration	SBA

The Bidder will not receive any subcontracting participation percentages if the Bidder fails to submit the required proof of certification.

BIDDING DOCUMENTS

LIST OF SUBCONTRACTORS

In accordance with the requirements provided in the "Subletting and Subcontracting Fair Practices Act", Division 2, Part 1, Chapter 4 of the Public Contract Code, the Bidder shall list below the name and address of each Subcontractor who will perform work, labor, render services or specially fabricates and installs a portion [type] of the work or improvement, in an amount in excess of 0.5% of the Contractor's total Bid. The Bidder shall also list below the portion of the work which will be done by each subcontractor under this Contract. The Contractor shall list only one Subcontractor for each portion of the Work. The **DOLLAR VALUE** of the total Bid to be performed shall be stated for all subcontractors listed. Failure to comply with this requirement shall result in the Bid being rejected as **non-responsive** and ineligible for award. The Bidder's attention is directed to the Special Provisions - General; Paragraph 2-3 Subcontracts, which stipulates the percent of the Work to be performed with the Bidders' own forces. The Bidder shall list all SLBE, ELBE, DBE, DVBE, MBE, WBE, OBE, SDB, WoSB, HUBZone, and SDVOSB Subcontractors that Bidders are seeking recognition towards achieving any mandatory, voluntary, or both subcontracting participation percentages.

Subcontractors' License Number must be filled in. Failure to provide the information specified may deem the bidder **non-responsive**.

NAME, ADDRESS AND TELEPHONE NUMBER OF SUBCONTRACTOR	CONSTRUCTOR OR DESIGNER	SUBCONTRACTOR LICENSE NUMBER	TYPE OF WORK	DOLLAR VALUE OF SUBCONTRACT (MUST BE FILLED OUT)	MBE, WBE, DBE, DVBE, OBE, ELBE, SLBE, SDB, WoSB, HUBZone, OR SDVOSB	WHERE CERTIFIED ②	CHECK IF JOINT VENTURE PARTNERSHIP
Name: <u>D&D WILDLIFE HABITAT & REST</u> Address: <u>9143 HARNESS ST</u> City: <u>SPRING VALLEY</u> State: <u>CA</u> Zip: <u>91977</u> Phone: <u>619-667-3707</u> Email: <u>NORMA@HABITATSRESTORATION.COM</u>	CONSTRUCTOR SERVICE	440492	HABITAT RESTORATION	\$79,813.00	ELBE	CITY OF SAN DIEGO	N/A
Name: <u>MOCON</u> Address: <u>49950 JEFFERSON ST. STE C200</u> City: <u>INDIO</u> State: <u>CA</u> Zip: <u>92201</u> Phone: <u>503-551-5223</u> Email: <u>ROB@MOCONTRENCHLESS.COM</u>	CONSTRUCTOR	565735	TRENCHLES	\$13,600.00	OBE	N/A	N/A

① As appropriate, Bidder shall identify Subcontractor as one of the following and shall include a valid proof of certification (except for OBE, SLBE and ELBE):

- | | | | |
|---|--------|--|---------|
| Certified Minority Business Enterprise | MBE | Certified Woman Business Enterprise | WBE |
| Certified Disadvantaged Business Enterprise | DBE | Certified Disabled Veteran Business Enterprise | DVBE |
| Other Business Enterprise | OBE | Certified Emerging Local Business Enterprise | ELBE |
| Certified Small Local Business Enterprise | SLBE | Small Disadvantaged Business | SDB |
| Woman-Owned Small Business | WoSB | HUBZone Business | HUBZone |
| Service-Disabled Veteran Owned Small Business | SDVOSB | | |

② As appropriate, Bidder shall indicate if Subcontractor is certified by:

- | | | | |
|--|--------|--|----------|
| City of San Diego | CITY | State of California Department of Transportation | CALTRANS |
| California Public Utilities Commission | CPUC | San Diego Regional Minority Supplier Diversity Council | SRMSDC |
| State of California's Department of General Services | CADoGS | City of Los Angeles | LA |
| State of California | CA | U.S. Small Business Administration | SBA |

The Bidder will not receive any subcontracting participation percentages if the Bidder fails to submit the required proof of certification.

BIDDING DOCUMENTS

NAMED EQUIPMENT/MATERIAL SUPPLIER LIST

The Bidder seeking the recognition of equipment, materials, or supplies obtained from Suppliers towards achieving any mandatory, voluntary, or both subcontracting participation percentages shall list the Supplier(s) on the Named Equipment/Material Supplier List. The Named Equipment/Material Supplier List, at a minimum, shall have the name, locations (City) and the **DOLLAR VALUE** of the Suppliers. The Bidder will be credited up to 60% of the amount to be paid to the Suppliers for such materials and supplies unless vendor manufactures or substantially alters materials and supplies in which case 100% will be credited. The Bidder is to indicate (Yes/No) whether listed firm is a supplier or manufacturer. In calculating the subcontractor participation percentages, vendors/suppliers will receive 60% credit of the listed **DOLLAR VALUE**, whereas manufacturers will receive 100% credit. If no indication provided, listed firm will be credited at 60% of the listed dollar value for purposes of calculating the Subcontractor Participation Percentage, Suppliers will receive 60% credit of the listed **DOLLAR VALUE**, whereas manufacturers will receive 100% credit. If no indication provided, listed firm will be credited at 60% of the listed **DOLLAR VALUE** for purposes of calculating the subcontractor participation percentages.

NAME, ADDRESS AND TELEPHONE NUMBER OF VENDOR/SUPPLIER	MATERIALS OR SUPPLIES	DOLLAR VALUE OF MATERIAL OR SUPPLIES (MUST BE FILLED OUT)	SUPPLIER (Yes/No)	MANUFACTURER (Yes/No)	MBE, WBE, DBE, DVBE, OBE, ELBE, SLBE, SDB, WoSB, HUBZone, OR SDVOSB	WHERE CERTIFIED
Name: _____ Address: _____ City: _____ State: _____ Zip: _____ Phone: _____ Email: _____						
Name: _____ Address: _____ City: _____ State: _____ Zip: _____ Phone: _____ Email: _____						

① As appropriate, Bidder shall identify Vendor/Supplier as one of the following and shall include a valid proof of certification (except for OBE,SLBE and ELBE):

Certified Minority Business Enterprise	MBE	Certified Woman Business Enterprise	WBE
Certified Disadvantaged Business Enterprise	DBE	Certified Disabled Veteran Business Enterprise	DVBE
Other Business Enterprise	OBE	Certified Emerging Local Business Enterprise	ELBE
Certified Small Local Business Enterprise	SLBE	Small Disadvantaged Business	SDB
Woman-Owned Small Business	WoSB	HUBZone Business	HUBZone
Service-Disabled Veteran Owned Small Business	SDVOSB		

② As appropriate, Bidder shall indicate if Vendor/Supplier is certified by:

City of San Diego	CITY	State of California Department of Transportation	CALTRANS
California Public Utilities Commission	CPUC	San Diego Regional Minority Supplier Diversity Council	SRMSDC
State of California's Department of General Services	CADoGS	City of Los Angeles	LA
State of California	CA	U.S. Small Business Administration	SBA

The Bidder will not receive any subcontracting participation percentages if the Bidder fails to submit the required proof of certification.

SEWER GROUP 691

LEGEND

IMPROVEMENTS	STANDARD DRAWINGS	SYMBOL
TRENCH RESURFACING	SDG-107 TYPE A, SDG-108	
SEWER MAIN	SDS-101, SDS-110 (TYPE C)	
SEWER MANHOLE/PVC LINED	SDS-106, SDS-107, SDS-108 SDM-113, SDS-120, M-3, SM-07	
REHAB. EX. SEWER MANHOLE	SEE PLANS & SPECS	
SEWER MAIN REHAB.	SEE PLANS & SPECS	
4" SEWER LATERAL WITH C.O. UNLESS OTHERWISE SPECIFIED	SDS-102, SDS-103, SDS-104, SDS-105, SDS-110 (TYPE C), SDS-118	
REPLUMB SEWER LATERAL WITH C.O.	SDS-102, SDS-103, SDS-104, SDS-105, SDS-110 (TYPE C), SDS-118	
SEWER LATERAL CONNECTION	SEE PLANS & SPECS	
SEWER PUMP INCLUDING REPLUMB SEWER LATERAL WITH C.O.	SDS-102, SDS-103, SDS-104, SDS-105, SDS-110 (TYPE C), SDS-118	
SERVICE LATERAL CONNECTION TO REHABILITATED SEWER	SEE PLANS & SPECS	
TUNNEL SEWER REPLUMB LATERAL WITH C.O.	SDS-102, SDS-103, SDS-104, SDS-105	
PIPE SUPPORT FOR UNDERCUT AC WATER MAIN	SDW-162	
ABANDON EX MANHOLE	SM-08	
SLURRY FILL ABANDONED SEWER MAIN	SEE PLANS & SPECS	
CONCRETE ANCHOR	SDS-114, SDW-162	
CUTOFF WALL	SDS-115, SDW-162	
SURVEY MONUMENT	M-10	

FOR ADDITIONAL SYMBOLS SEE RESURFACING, CURB RAMP, AND HORIZONTAL ALIGNMENT COORDINATE.

CONTRACTOR'S RESPONSIBILITIES

- PURSUANT TO SECTION 4216 OF THE GOVERNMENT CODE, AT LEAST 2 WORKING DAYS PRIOR TO EXCAVATION, YOU MUST CONTACT THE REGIONAL NOTIFICATION CENTER (e.g., UNDERGROUND SERVICE ALERT OF SOUTHERN CALIFORNIA) AND OBTAIN AN INQUIRY IDENTIFICATION NUMBER.
- NOTIFY SDG&E AT LEAST 10 WORKING DAYS PRIOR TO EXCAVATING WITHIN 10' OF SDG&E UNDERGROUND HIGH VOLTAGE TRANSMISSION POWER LINES, (i.e., 69 KV & HIGHER)
- LOCATE AND RECONNECT ALL SEWER LATERALS. LOCATIONS AS SHOWN ON THE PLANS ARE APPROXIMATE ONLY. LATERAL RECORDS ARE AVAILABLE TO THE CONTRACTOR AT THE PUBLIC UTILITIES DEPARTMENT, 2797 CAMINITO CHOLLAS. LOCATE THE IMPROVEMENTS THAT WILL BE AFFECTED BY LATERAL REPLACEMENTS.
- THE LOCATIONS OF EXISTING BUILDINGS AS SHOWN ON THE PLAN ARE APPROXIMATE.
- KEEP STORM DRAIN INLETS FUNCTIONAL AT ALL TIMES DURING CONSTRUCTION.
- UNLESS OTHERWISE NOTED AS PREVIOUSLY POTHOLED (PH), ELEVATIONS SHOWN ON THE PROFILE FOR EXISTING UTILITIES ARE BASED ON A SEARCH OF THE AVAILABLE RECORD INFORMATION ONLY AND ARE SOLELY FOR THE CONTRACTOR'S CONVENIENCE. THE CITY DOES NOT GUARANTEE THAT IT HAS REVIEWED ALL AVAILABLE DATA. THE CONTRACTOR SHALL POT-HOLE ALL EXISTING UTILITIES EITHER SHOWN ON THE PLANS OR MARKED IN THE FIELD IN ACCORDANCE WITH THE SPECIFICATIONS SECTION 5-1.
- EXISTING UTILITY CROSSING AS SHOWN ON THE PLANS ARE APPROXIMATE AND ARE NOT REPRESENTATIVE OF ACTUAL LENGTH AND LOCATION OF CONFLICT AREAS. SEE PLAN VIEW.

LIMITS OF WORK

SHEET NO.	DISCIPLINE CODE	TITLE	LIMITS	PIPE		LENGTH (FT)
				SIZE (IN)	MATERIAL	
1	G-1	COVER SHEET	HAWTHORN TO GRAPE ST	8	SEWER	134.00
2	C-1	28TH STREET	HAWTHORN TO GRAPE ST	6	REHAB	161.00
3	C-1	28TH STREET	28TH ST TO GRANADA AVE	8	SEWER	200.00
4	C-2	HAWTHORN STREET	N/O HAWTHORN ST TO IVY/28TH ST TO 29TH ST	8	SEWER	723.00
5	C-3	28TH STREET/IVY STREET	E/O 30TH ST TO E/O 31ST ST	8	SEWER	600.00
6	C-4	ALLEY BLK A, B, 7, & 8	E/O 31ST ST TO 32ND ST	8	SEWER	354.73
7	C-5	ALLEY BLK B & 7	W/O 28TH ST TO 29TH ST	8	SEWER	700.00
8	C-6	JUNIPER ST	JUNIPER ST TO ALLEY BLK 8, 68	8	SEWER	294.80
9	C-7	JUNIPER ST/29TH ST	29TH ST TO 30TH ST	8	SEWER	695.44
10	C-7	ALLEY BLK 8, 68	S/O KALMIA ST	8	SEWER	97.01
11	C-8	30TH STREET	W/O 29TH ST	-	-	-
12	C-8	KALMIA PLACE	N/O BURLINGAME DR TO MAPLE ST	8	REHAB	220.06
13	C-9	EASEMENT BLK H & N	MAPLE CT TO KALMIA ST	8	SEWER	190.20
14	C-10	30TH STREET	N/O LAUREL ST	-	-	-
15	C-11	SAN MARCOS AVENUE		-	-	-
				TOTAL SEWER		4360.24

WORK TO BE DONE

CONSTRUCTION OF SEWER GROUP 691 CONSISTS OF THE REPLACEMENT OF APPROXIMATELY 4,360 LINEAR FEET (LF) OF PIPE, CONSISTING OF OPEN TRENCH REPLACEMENT, SEWER MAIN REHABILITATION, SEWER MAIN ABANDONMENT, WITH REPLACEMENT AND REPLUMB SEWER LATERALS, RESURFACING AND CURB RAMP REPLACEMENTS, AND ALL OTHER WORK AND APPURTENANCES IN ACCORDANCE WITH THESE SPECIFICATIONS AND DRAWINGS NUMBERED 32506-01 THROUGH 32506-21-D.

DISCIPLINE CODE

- G GENERAL
- C CIVIL

STORM WATER PROTECTION

- THIS PROJECT IS SUBJECT TO MUNICIPAL STORM WATER PERMIT ORDER NO. R9-2007-0001 AND WPCP.

ABBREVIATIONS

ABAND	ABANDON	EB	ENCASED BURIED	OVD	OVER HEAD
ABAND'D	ABANDONED	EL, ELEV	ELEVATION	PVC	POLYVINYL CHLORIDE
AC	ASBESTOS CEMENT PIPE	ELEC	ELECTRIC	PROP	PROPOSED
AHD	AHEAD	EX, EXIST	EXISTING	RED	REDUCER
ASSY	ASSEMBLY	E/O	EAST OF	RT	RIGHT
BK	BACK	F	FLANGE	S	SURVEY LINE
BTWN	BETWEEN	GV	GATE VALVE	SO	STUB OUT
CATV	CABLE TV	HDPE	HIGH-DENSITY POLYETHYLENE	S/O	SOUTH OF
CI	CAST IRON PIPE	HP	HIGH PRESSURE	SWR	SEWER
C	CENTER LINE	IE	INVERT ELEVATION	TEL	TELEPHONE
COND	CONDUIT	LT	LEFT	UNK	UNKNOWN
CONT	CONTINUED	MJ	MECHANICAL JOINT	VC	VITRIFIED CLAY PIPE
CONTR	CONTRACTOR	MTD	MULTIPLE TELEPHONE DUCT	WM	WATER METER
DB	DIRECT BURIED	N/O	NORTH OF	WTR	WATER
				W/O	WEST OF

EXISTING STRUCTURES

EX WATER MAIN & VALVES	
EX WATER METER	
EX FIRE HYDRANT	
EX SEWER MAIN & MANHOLES	
EX DRAINS	
EX PAVEMENT (PROFILE)	
EX GROUND LINE (PROFILE)	
EX TRAFFIC SIGNAL	
EX STREET LIGHT	
GAS MAIN	
ELEC. COND., TEL. COND., CATV	
RAILROAD, TROLLEY TRACKS	

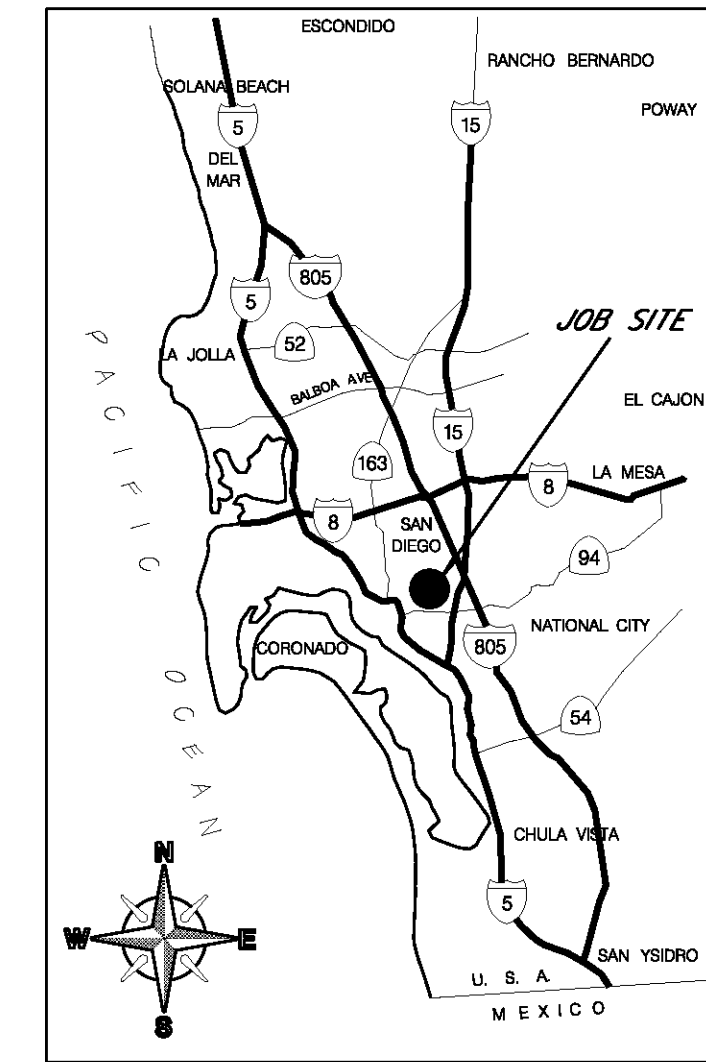
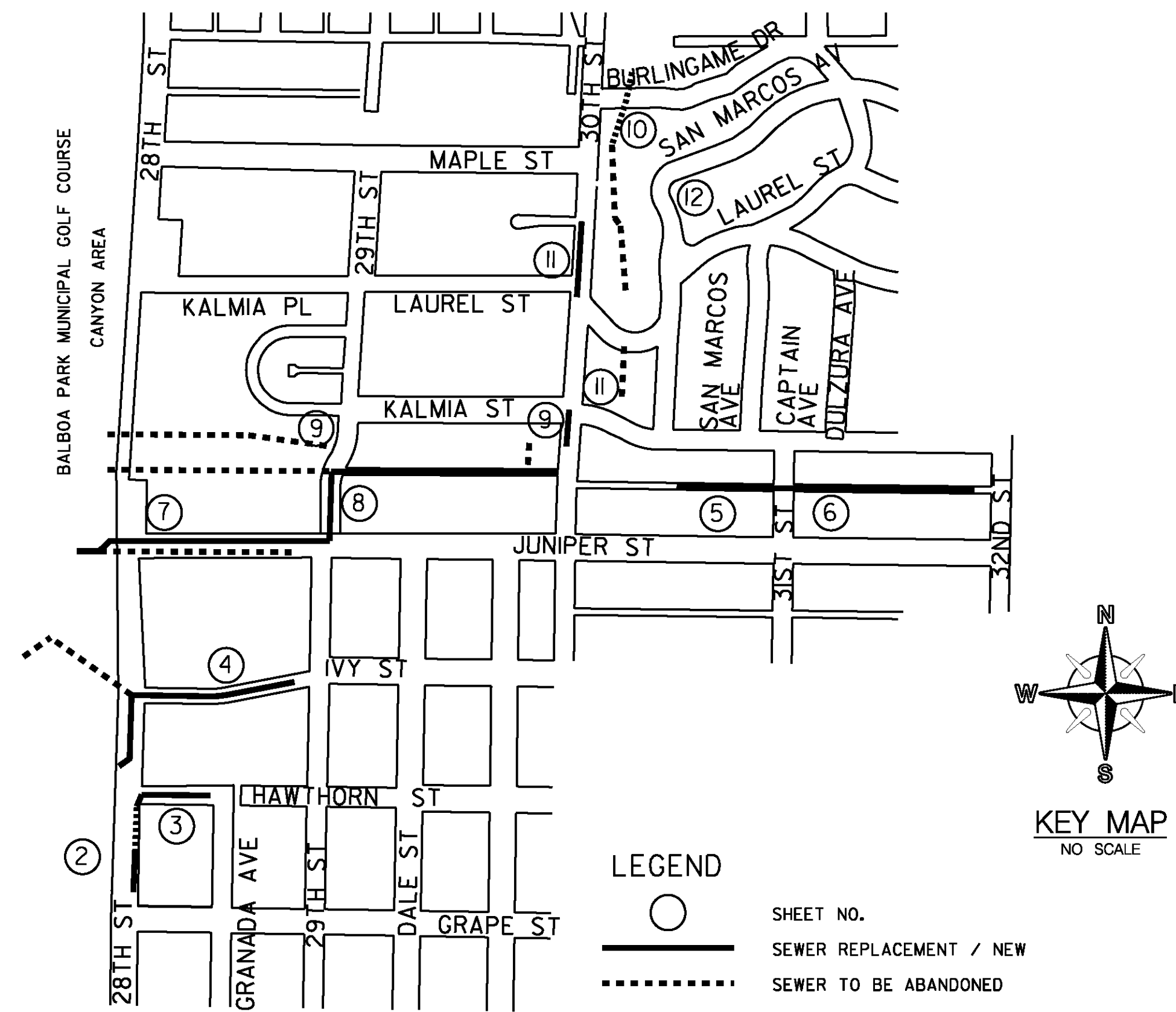

VICINITY MAP
NOT TO SCALE

FIELD DATA

BENCHMARK: SBP 295.1 SAN MARCOS @ BURLINGAME
 FIELD NOTES: DAVIS, 204-1725, 11-02-2002
 DATUM: MEAN SEA LEVEL
 STREETS REQUIRING 12" TRENCH CAP: 30TH STREET

AS-BUILT INFORMATION	
MATERIALS	MANUFACTURER
PIPE CL 235 (WATER)	-
PIPE SDR 35 (SEWER)	-
GATE VALVES	-
FIRE HYDRANTS	-
SEWER MANHOLES	-
REHABILITATE SEWER MANHOLES	-
REHABILITATE SEWER MAIN	-



PLANS FOR THE CONSTRUCTION OF SEWER GROUP 691 COVER SHEET

CITY OF SAN DIEGO, CALIFORNIA PUBLIC WORKS DEPARTMENT SHEET 01 OF 21 SHEETS		WATER WBS - SEWER WBS B-00446
APPROVED BY: RANIA AMEN FOR CITY ENGINEER DCE NAME	DATE: 7/14/2014	DESIGNED BY: JERICO GALLARDO PROJECT MANAGER
DESCRIPTION: ORIGINAL	BY: JG/JG	APPROVED: [Signature]
DATE: [Blank]		FILED: [Blank]
DATE COMPLETED: [Blank]		CONTRACTOR: [Blank]
DATE STARTED: [Blank]		INSPECTOR: [Blank]

NO. C 63507
09-30-2004
CIVIL
STATE OF CALIFORNIA

CONSTRUCTION CHANGE / ADDENDUM			
CHANGE	DATE	AFFECTED OR ADDED SHEET NUMBERS	APPROVAL NO.

WARNING

IF THIS BAR DOES NOT MEASURE 1" THEN DRAWING IS NOT TO SCALE.

**CITY OF SAN DIEGO
PUBLIC WORKS PROJECT**



G-1

SEWER GROUP 691

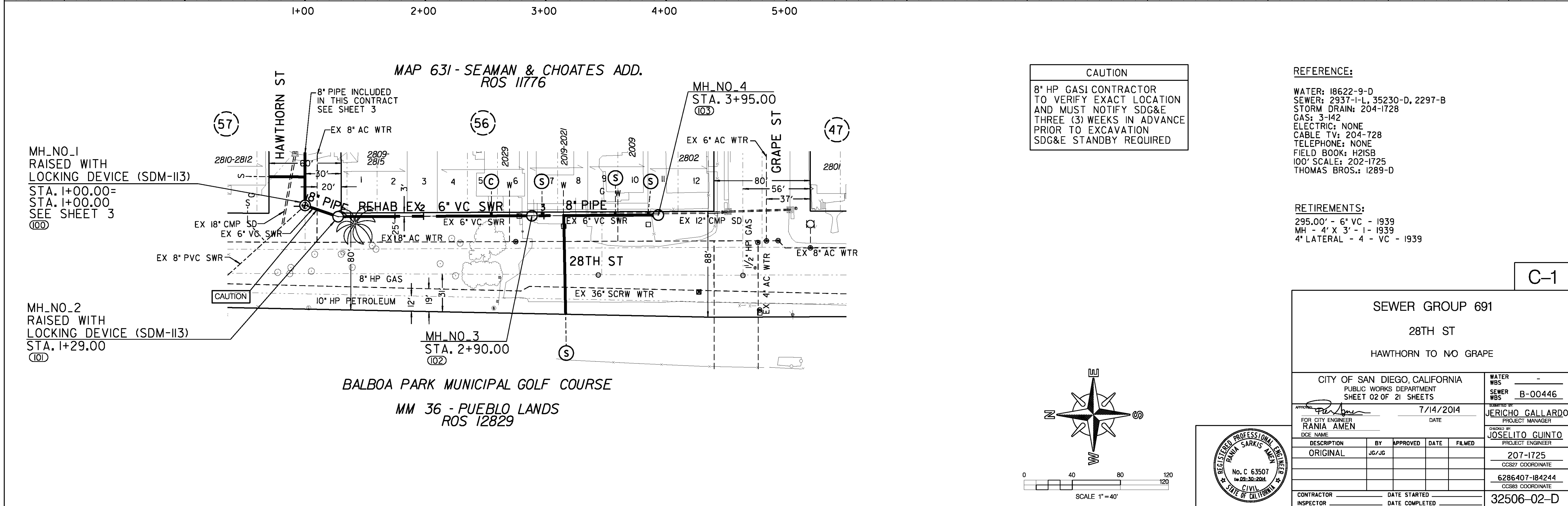
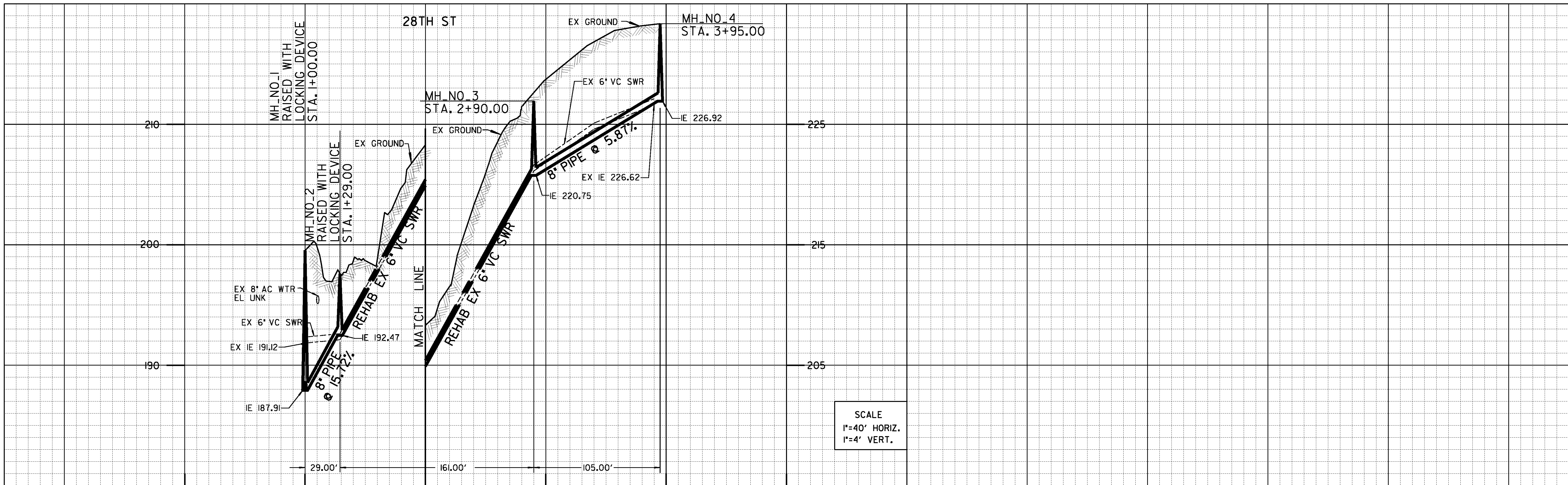

CAUTION
 8" HP GAS CONTRACTOR TO VERIFY EXACT LOCATION AND MUST NOTIFY SDG&E THREE (3) WEEKS IN ADVANCE PRIOR TO EXCAVATION SDG&E STANDBY REQUIRED

REFERENCE:
 WATER: 18622-9-D
 SEWER: 2937-1-L, 35230-D, 2297-B
 STORM DRAIN: 204-1728
 GAS: 3-142
 ELECTRIC: NONE
 CABLE TV: 204-728
 TELEPHONE: NONE
 FIELD BOOK: H215B
 100' SCALE: 202-1725
 THOMAS BROS.: 1289-D

RETIREMENTS:
 295.00' - 6" VC - 1939
 MH - 4' X 3' - 1 - 1939
 4' LATERAL - 4 - VC - 1939

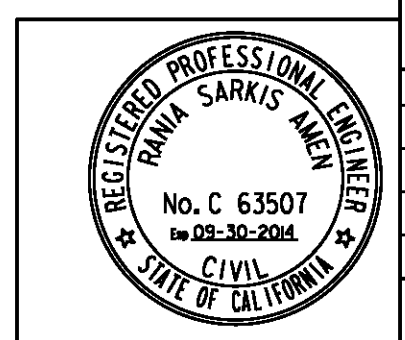
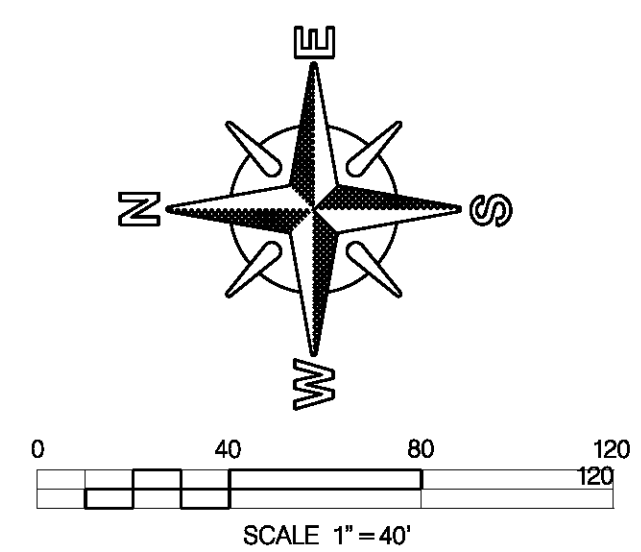

SEWER GROUP 691 28TH ST HAWTHORN TO NO GRAPE				
CITY OF SAN DIEGO, CALIFORNIA PUBLIC WORKS DEPARTMENT SHEET 02 OF 21 SHEETS				
APPROVED BY: <i>Rania Amen</i> FOR CITY ENGINEER RANIA AMEN DATE: 7/14/2014	WATER WBS: - SEWER WBS: B-00446 DESIGNED BY: JERICO GALLARDO PROJECT MANAGER CHECKED BY: JOSELITO QUINTO PROJECT ENGINEER			
DESCRIPTION	BY	APPROVED	DATE	FILMED
ORIGINAL	JG/JG			
207-1725 CCS27 COORDINATE 6286407-184244 CCS83 COORDINATE				
CONTRACTOR		DATE STARTED		32506-02-D
INSPECTOR		DATE COMPLETED		

C-1

28TH ST

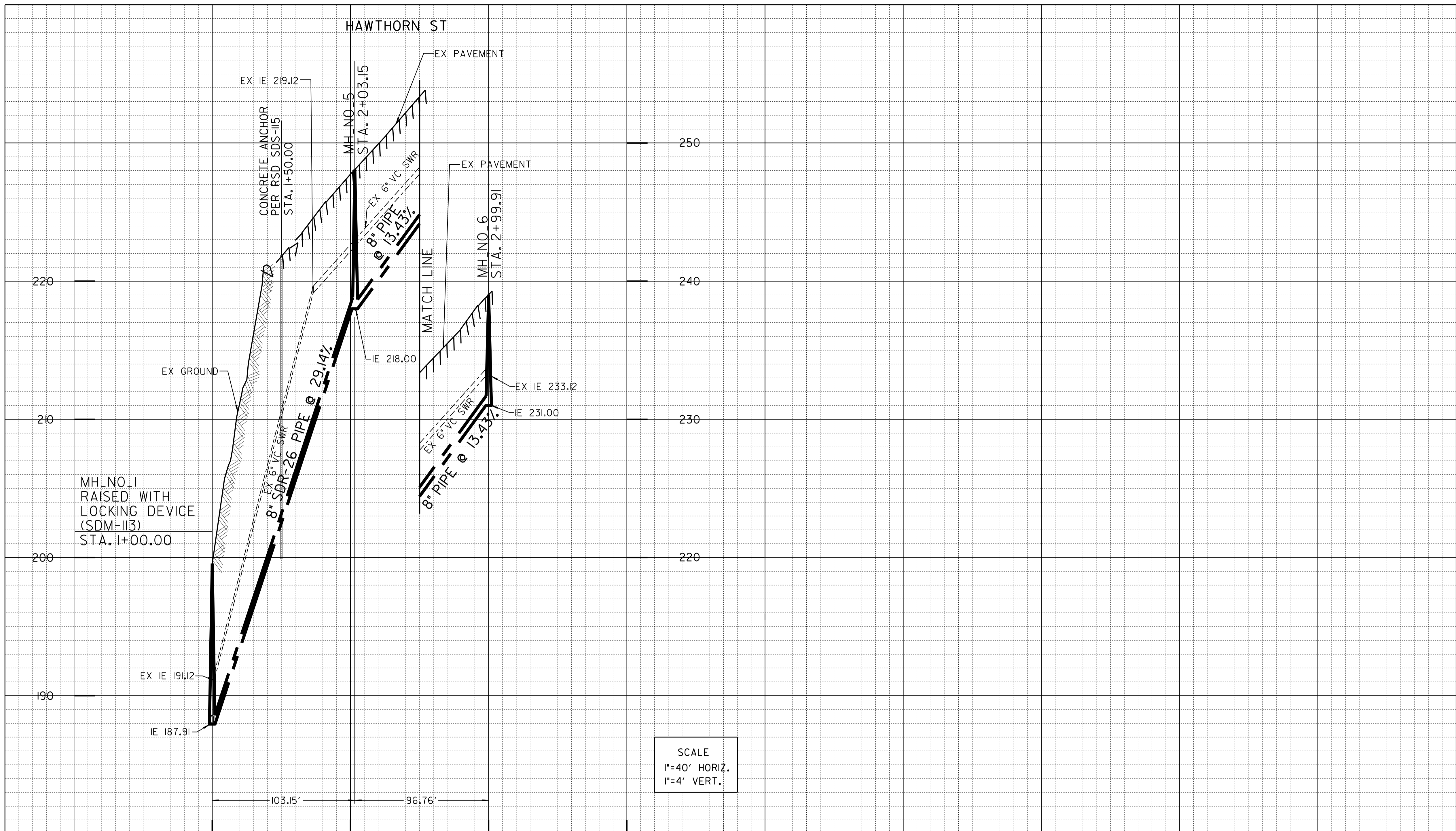

SCALE
 1"=40' HORIZ.
 1"=4' VERT.

REFERENCE:

WATER: 11485-6-D
 SEWER: 2937-L
 STORM DRAIN: 204-1728
 GAS: 3-142
 ELECTRIC: NONE
 CABLE TV: 204-728
 TELEPHONE: NONE
 FIELD BOOK: H215B
 100' SCALE: 202-1725
 THOMAS BROS.: 1289-E1

RETIREMENTS:

200.00' - 6" VC - 1928
 MH - 4' X 3' - 1 - 1928
 4" LATERAL - 7 - VC - 1928

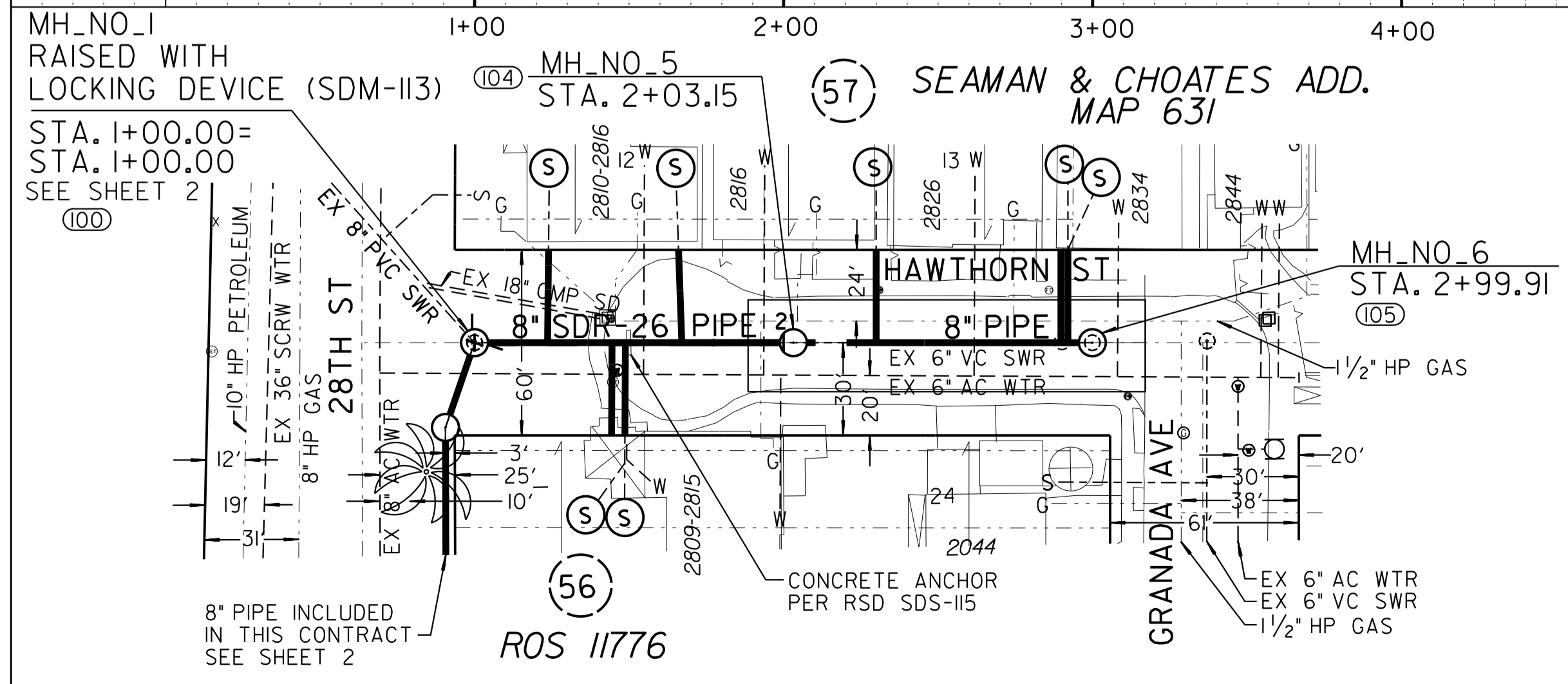

CONTRACTORS NOTE:
 USE EXTREME CAUTION WHEN WORKING DUE TO LOW OVERHEAD UTILITY LINES.

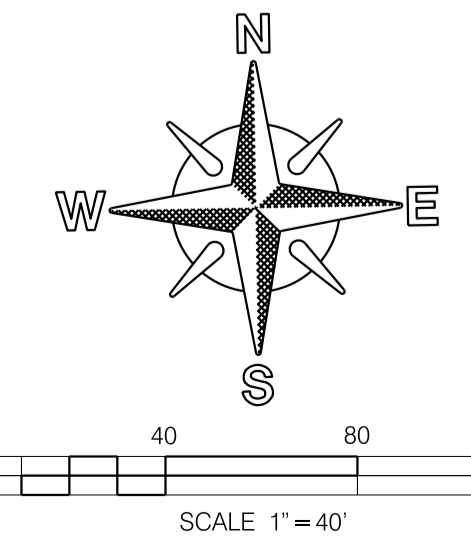

SEWER GROUP 691
HAWTHORN STREET
 28TH ST TO GRANADA AVE

CITY OF SAN DIEGO, CALIFORNIA PUBLIC WORKS DEPARTMENT SHEET 03 OF 21 SHEETS		WATER WBS - SEWER WBS B-00446
APPROVED FOR CITY ENGINEER <i>Rania Sarkis</i> RANIA SARKIS DCE NAME	DATE 7/14/2014	PROJECT MANAGER JERICHO GALLARDO
CHIEF ENGINEER JOSELITO GUINTO	PROJECT ENGINEER 207-1725	COORDINATOR 6286407-184244
DESCRIPTION	BY	APPROVED
ORIGINAL	JG/JG	
DATE		FILMED
CONTRACTOR	DATE STARTED	32506-03-D
INSPECTOR	DATE COMPLETED	

C-2

HAWTHORN ST

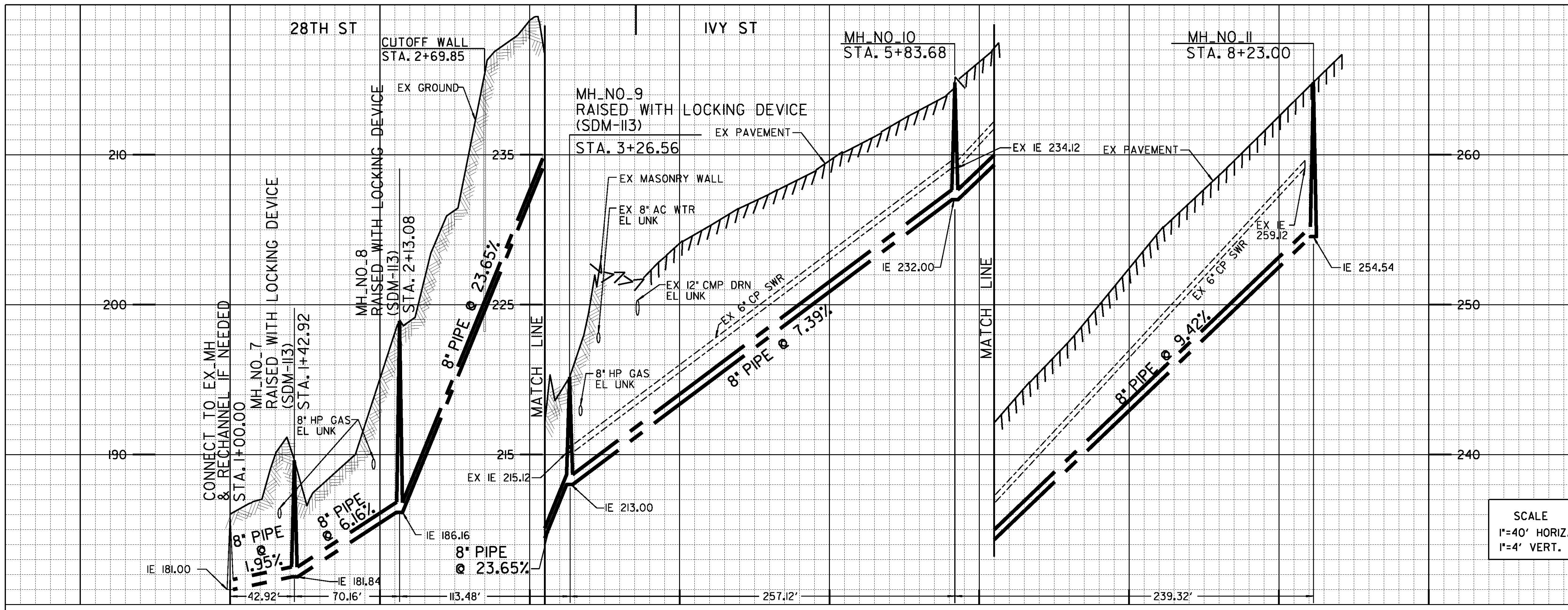

SCALE
1"=40' HORIZ.
1"=4' VERT.

REFERENCE:

WATER: 9661-2-D, 18622-10-D
SEWER: 4944-1-L, 11788-4-D
STORM DRAIN: 204-1728
GAS: 3-142, 3-143
ELECTRIC: NONE
CABLE TV: 204-728
TELEPHONE: NONE
FIELD BOOK: H215B
100' SCALE: 202-1725
THOMAS BROS.: 1289-EI

RETIREMENTS:

490.79' - 6" CP - 1932
MH - 4' X 3' - 2 - 1932
4" LATERAL - 18 - UNK - 1932

CONTRACTOR'S NOTE:
1. 8" HP GAS CONTRACTOR TO VERIFY EXACT LOCATION AND MUST NOTIFY SDG&E THREE (3) WEEKS IN ADVANCE PRIOR TO EXCAVATION. SDG&E STANDBY REQUIRED.
2. USE EXTREME CAUTION WHEN WORKING DUE TO LOW OVERHEAD UTILITY LINES

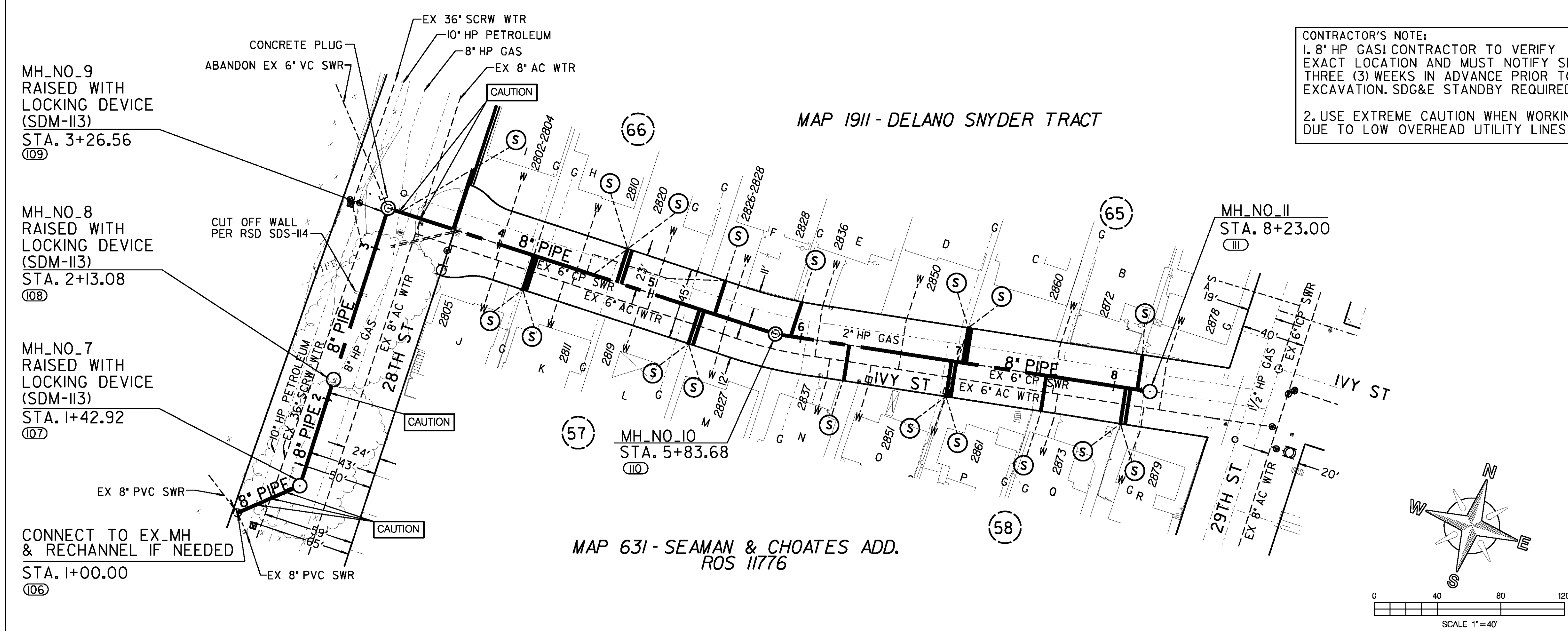

MAP 1911 - DELANO SNYDER TRACT

MAP 631 - SEAMAN & CHOATES ADD. ROS 11776

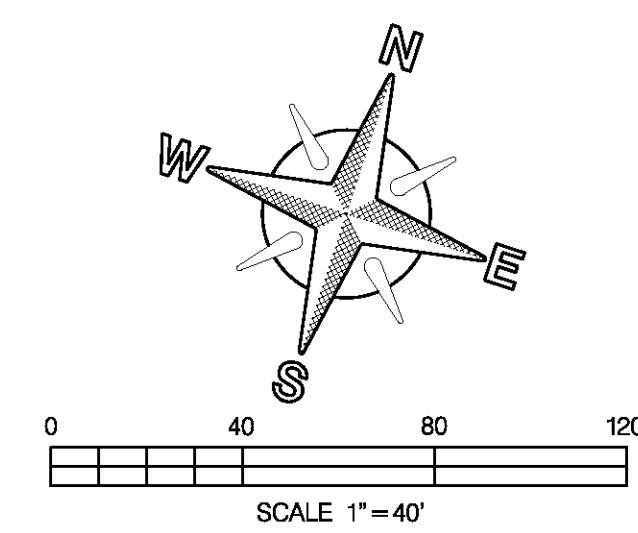

SEWER GROUP 691			
28TH STREET /IVY STREET			
NO HAWTHORN ST TO 29TH ST			
CITY OF SAN DIEGO, CALIFORNIA PUBLIC WORKS DEPARTMENT SHEET 04 OF 21 SHEETS		WATER WBS - SEWER WBS B-00446	
APPROVED: <i>[Signature]</i> FOR CITY ENGINEER RANIA AMEN DATE 7/14/2014		PROJECT MANAGER JERICHO GALLARDO	
DCE NAME		PROJECT ENGINEER JOSELITO QUINTO	
DESCRIPTION	BY	APPROVED	DATE
ORIGINAL	JG/JG		
PROJECT NUMBER 207-1725		COORDINATE CCS27	
PROJECT NUMBER 6286407-184244		COORDINATE CCS83	
CONTRACTOR	DATE STARTED		23506-04-D
INSPECTOR	DATE COMPLETED		

C-3

28TH STREET /IVY STREET

ALLEY BLK A, B, 8, & 7

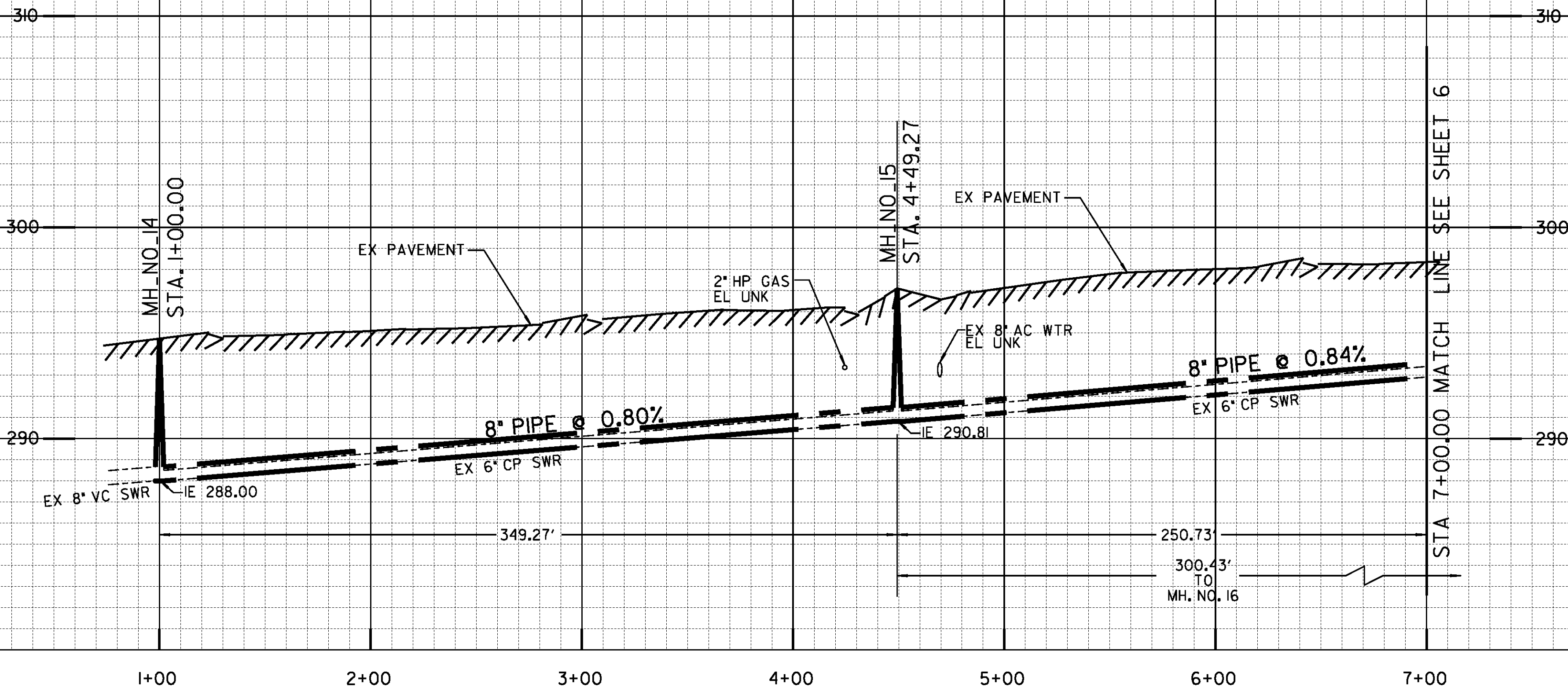

SCALE
1"=40' HORIZ.
1"=4' VERT.

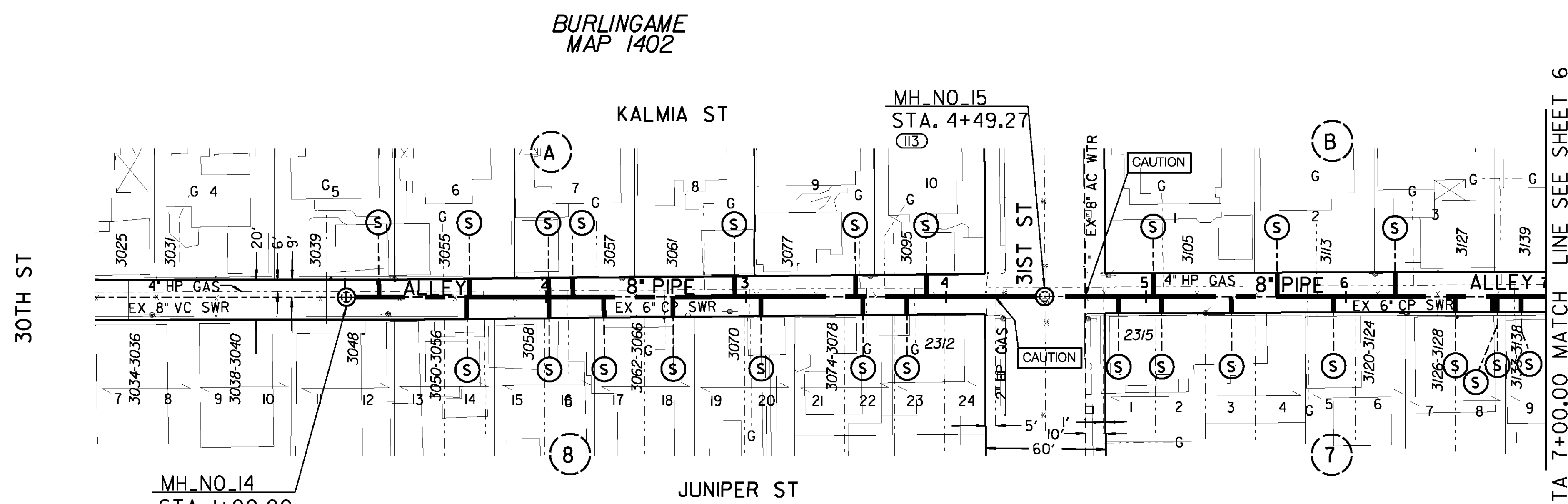

REFERENCE:
WATER: 11622-10-D
SEWER: 94-D
STORM DRAIN: NONE
GAS: 3-200, 3-201A
ELECTRIC: NONE
CABLE TV: NONE
TELEPHONE: NONE
IMPROVEMENTS: NONE
100' SCALE: 206-1725
FIELD BOOK: H20S
THOMAS BROS.: I298E1

RETIREMENTS:
6" - CP - 600.00' - 1952
MH - 4' X 3' - 2 - 1952
4" LATERAL - 25 - UNK- 1952

CONTRACTOR'S NOTE:
1. 4" HP GAS CONTRACTOR TO VERIFY EXACT LOCATION AND MUST NOTIFY SDG&E THREE (3) WEEKS IN ADVANCE PRIOR TO EXCAVATION. SDG&E STANDBY REQUIRED.
2. USE EXTREME CAUTION WHEN WORKING DUE TO LOW OVERHEAD UTILITY LINES

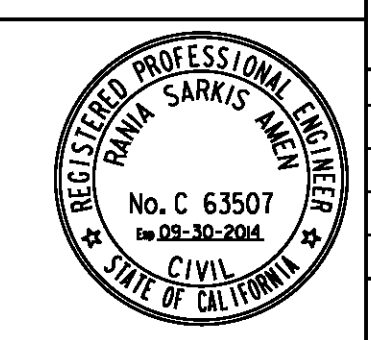
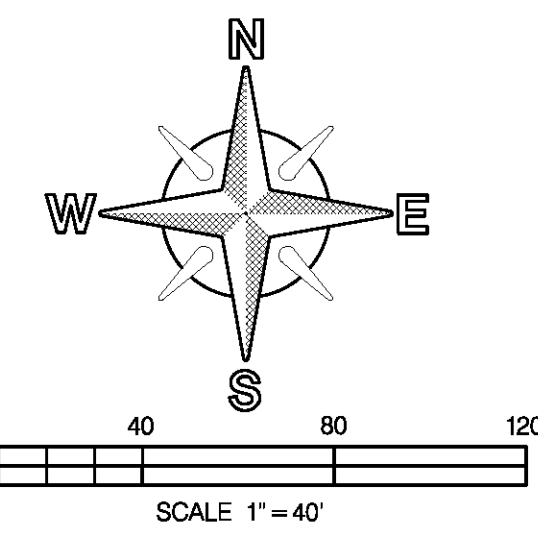

SEWER GROUP 691 ALLEY BLK A, B, 8, & 7 EO 30TH ST TO EO 31ST ST				
CITY OF SAN DIEGO, CALIFORNIA PUBLIC WORKS DEPARTMENT SHEET 05 OF 21 SHEETS	WATER WBS - SEWER WBS B-00446			
APPROVED BY: <i>Rania Sarkis</i> FOR CITY ENGINEER RANIA AMEN DATE: 7/14/2014	DESIGNED BY: JOSELITO GUINTO PROJECT ENGINEER			
DESCRIPTION	BY	APPROVED	DATE	FILMED
ORIGINAL	JG/JG			
CONTRACTOR		DATE STARTED		207-1725
INSPECTOR		DATE COMPLETED		6286407-184244 CCS83 COORDINATE
				32506-05-D

C-4

ALLEY BLK A, B, 8, & 7

ALLEY BLK B & 7

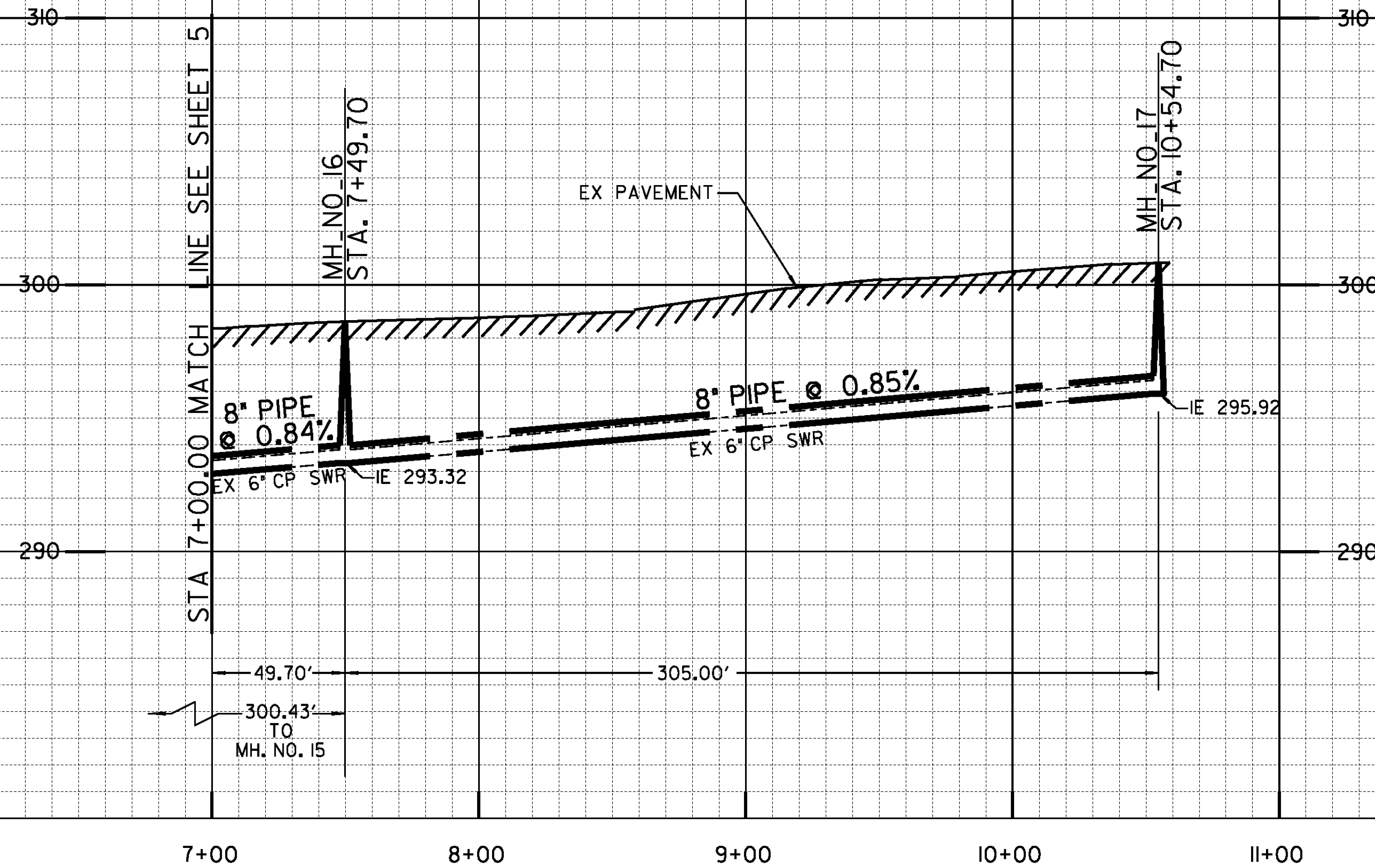

SCALE
1"=40' HORIZ.
1"=4' VERT.

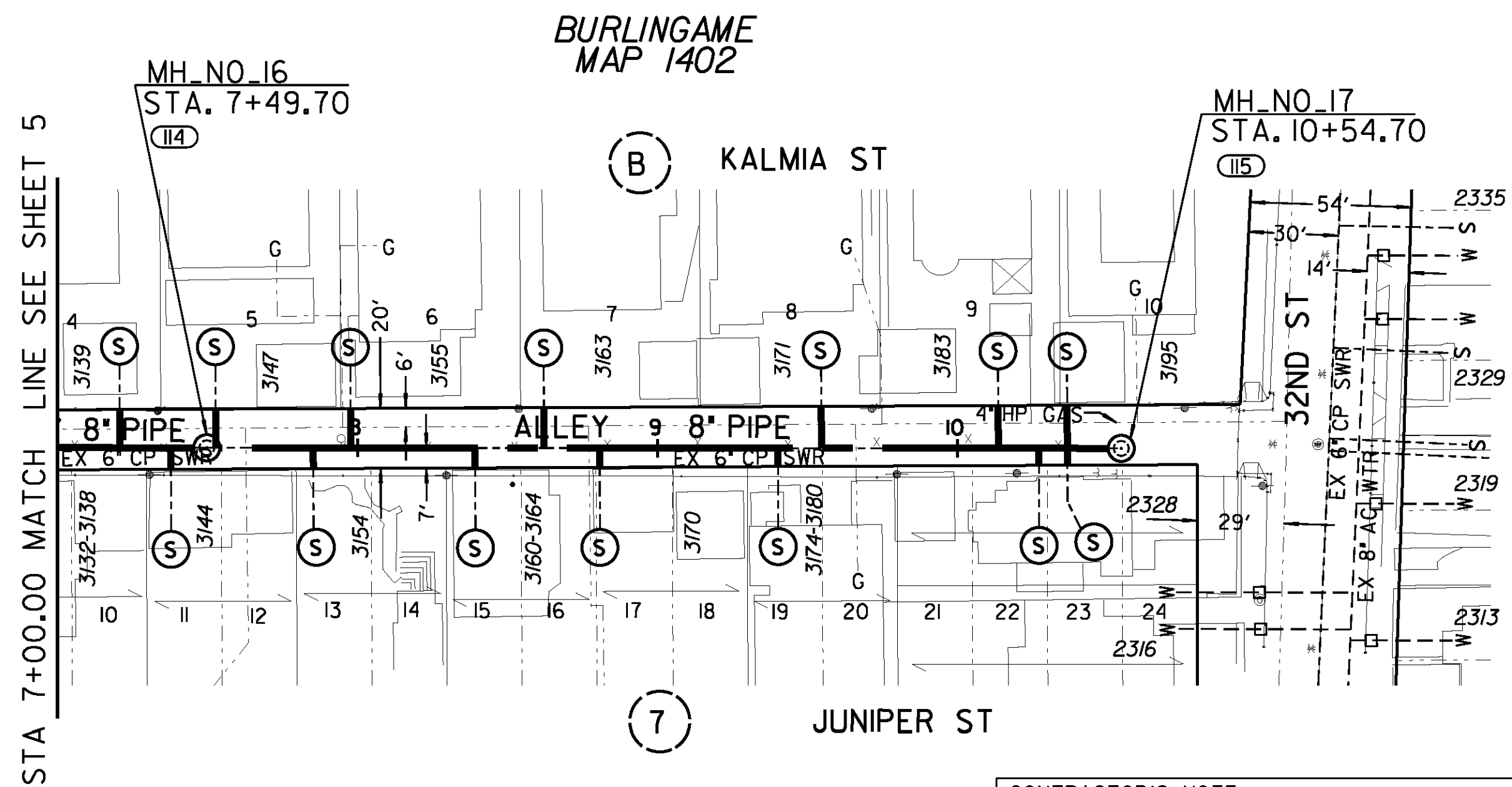

REFERENCE:
WATER: 11622-10-D
SEWER: 94-D
STORM DRAIN: NONE
GAS: NONE
ELECTRIC: NONE
CABLE TV: 3-200
TELEPHONE: NONE
IMPROVEMENTS: NONE
100' SCALE: 206-1725
FIELD BOOK: H20S
THOMAS BROS.: 1298E1

RETIREMENTS:
6" - CP - 354.73' - 1952
MH - 4' X 3' - 2 - 1952
4' LATERAL - 14 - UNK - 1952

WATKINS & BIDDLE ADD.
MAP 258
ROS 8796

CONTRACTOR'S NOTE:
1. 4" HP GAS: CONTRACTOR TO VERIFY EXACT LOCATION AND MUST NOTIFY SDG&E THREE (3) WEEKS IN ADVANCE PRIOR TO EXCAVATION. SDG&E STANDBY REQUIRED.
2. USE EXTREME CAUTION WHEN WORKING DUE TO LOW OVERHEAD UTILITY LINES

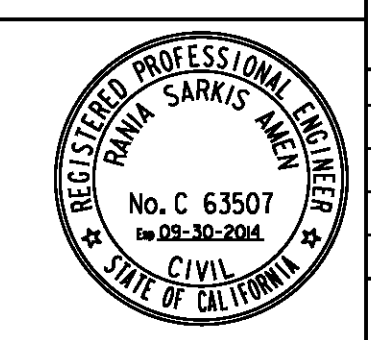
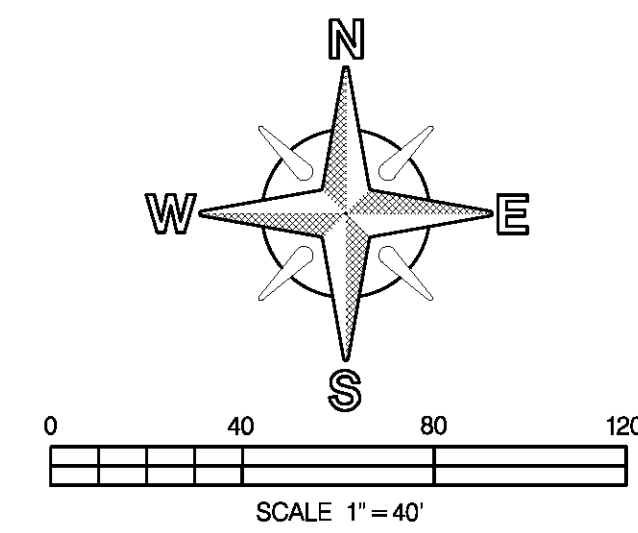

SEWER GROUP 691		ALLEY BLK B & 7		EO 31ST ST TO 32ND ST	
CITY OF SAN DIEGO, CALIFORNIA PUBLIC WORKS DEPARTMENT SHEET 06 OF 21 SHEETS				WATER WBS - SEWER WBS B-00446	
APPROVED BY: <i>[Signature]</i> FOR CITY ENGINEER RANIA AMEN		DATE: 7/14/2014		DESIGNED BY: JERICO GALLARDO PROJECT MANAGER	
DCE NAME:		PROJECT ENGINEER: JOSELITO QUINTO		NO. 207-1725	
DESCRIPTION: ORIGINAL		BY: JG/JG	APPROVED:	DATE:	FILED:
CONTRACTOR:		DATE STARTED:		6286407-184244	
INSPECTOR:		DATE COMPLETED:		CCS83 COORDINATE: 32506-06-D	

C-5

ALLEY BLK B & 7

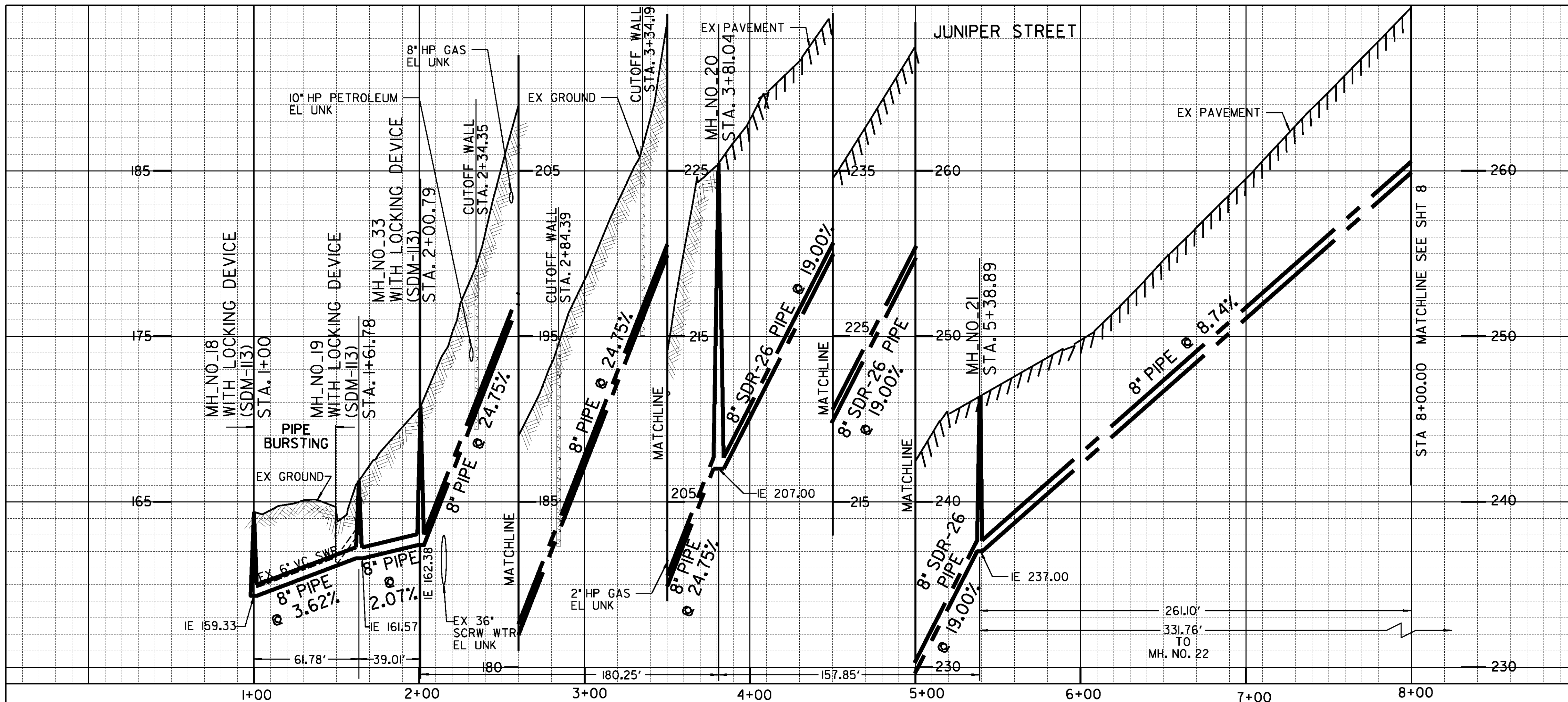

- NOTES:**
- SEWER LATERALS WITH PRIVATE REPLUMBING ARE SHOWN SCHEMATICALLY FOR BIDDING PURPOSES ONLY. THE ACTUAL LOCATION AND LENGTH OF EACH SEWER LATERAL SHALL BE DETERMINED IN THE FIELD AND IN ACCORDANCE WITH SECTION 306-I.8 OF THE SPECIFICATIONS. THE CONTRACTOR SHALL PERFORM ALL WORK NECESSARY TO CONNECT EXISTING HOUSE PLUMBING TO THE NEW SEWER LATERAL IN ACCORDANCE WITH THE SPECIFICATIONS, UNIFORM BUILDING CODE, AND UNIFORM PLUMBING CODE. ANY PRIVATE IMPROVEMENTS DAMAGED OR DISTURBED AS A RESULT OF THIS REPLUMBING WORK SHALL BE RESTORED BY THE CONTRACTOR TO ITS ORIGINAL CONDITION.
 - THE REPLUMBING WORK MAY REQUIRE HAND EXCAVATION.
 - BEFORE INSTALLING NEW SEWER MAIN, THE CONTRACTOR SHALL INVESTIGATE/POT-HOLE EXISTING HOUSE PLUMBING TO ENSURE THE MINIMUM 2% SLOPE OF NEW SEWER LATERAL CAN BE ACHIEVED.
 - TRENCHLESS METHOD MAY BE REQUIRED FOR INSTALLATION OF SEWER LATERALS WITH PRIVATE REPLUMBING.

SPECIAL NOTE:
SPECIAL SHORING IS REQUIRED FOR TRENCHING BETWEEN STA. 2+00.79 AND STA. 3+81.04 SEE SECTION 306-I.1.6 OF THE SPECIFICATIONS.

SCALE
1"=40' HORIZ.
1"=4' VERT.

CONTRACTOR'S NOTE:
1. 8" & 2" HP GAS CONTRACTOR TO VERIFY EXACT LOCATION AND MUST NOTIFY SDG&E THREE (3) WEEKS IN ADVANCE PRIOR TO EXCAVATION. SDG&E STANDBY REQUIRED.
2. USE EXTREME CAUTION WHEN WORKING DUE TO LOW OVERHEAD UTILITIES.
3. FOR REPLUMB DETAILS SEE SHEET 14 & 15.

- MH_NO_20
STA. 3+81.04
(119)
- BRICK WALL WITH WOODEN BARRICADE ON TOP
- MH_NO_33
WITH LOCKING DEVICE
(SDM-II3)
STA. 2+00.79
(118)
- MH_NO_18
WITH LOCKING DEVICE
(SDM-II3)
STA. 1+00
(116)
- MH_NO_19
WITH LOCKING DEVICE
(SDM-II3)
STA. 1+61.78
(117)

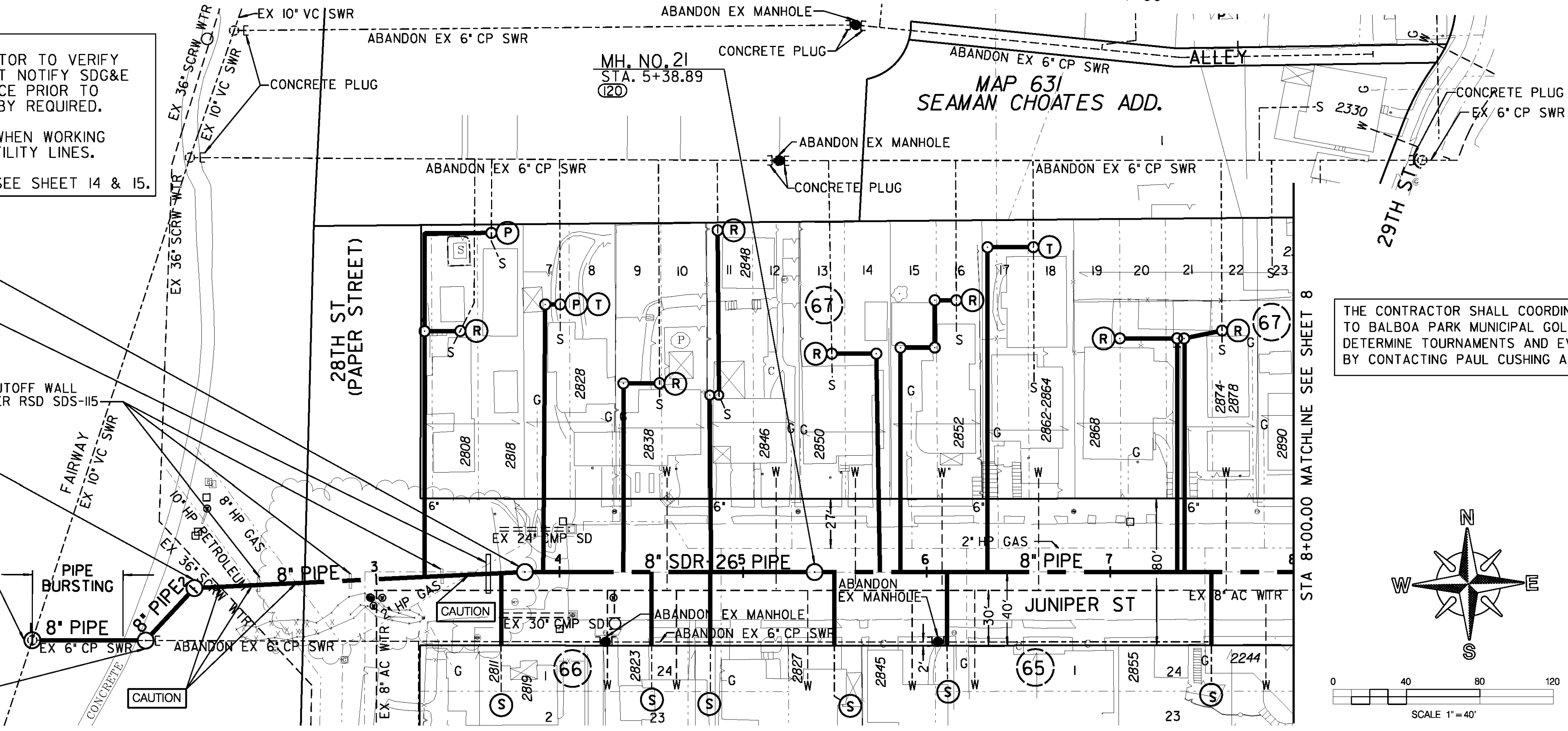

THE CONTRACTOR SHALL COORDINATE ACCESS TO BALBOA PARK MUNICIPAL GOLF COURSE AND DETERMINE TOURNAMENTS AND EVENTS SCHEDULE BY CONTACTING PAUL CUSHING AT (858) 552-1606.

- REFERENCE:**
- WATER: 11485-8-D, 2156-L
 - SEWER: 5384-L, 450-D, 11788-5-D, 950-D
 - STORM DRAIN: 204-1728
 - GAS: 3-203
 - ELECTRIC: NONE
 - CABLE TV: 204-728
 - TELEPHONE: NONE
 - FIELD BOOK: H215B
 - 100' SCALE: 202-1725, 206-1725
 - THOMAS BROS.: 1289-EI
- RETIREMENTS:**
- 1935.46' - 6" CP - 1932
 - MH - 4' X 3' - 5 - 1932
 - 4" LATERAL - 17 - CP - 1932

C-6

SEWER GROUP 691			
JUNIPER STREET			
WO 28TH ST TO WO 29TH ST			
CITY OF SAN DIEGO, CALIFORNIA PUBLIC WORKS DEPARTMENT SHEET 07 OF 21 SHEETS		WATER WBS - SEWER WBS B-00446	
FOR CITY ENGINEER RANIA AMEN DATE 7/14/2014		PROJECT MANAGER JERICHO GALLARDO	
DESIGNED BY JOSELITO GUINTO		PROJECT ENGINEER JOSELITO GUINTO	
DESCRIPTION	BY	APPROVED	DATE
ORIGINAL	JG/JG		
207-1725		CCS27 COORDINATE	
6286407-184244		CCS88 COORDINATE	
CONTRACTOR	DATE STARTED	32506-07-D	
INSPECTOR	DATE COMPLETED		

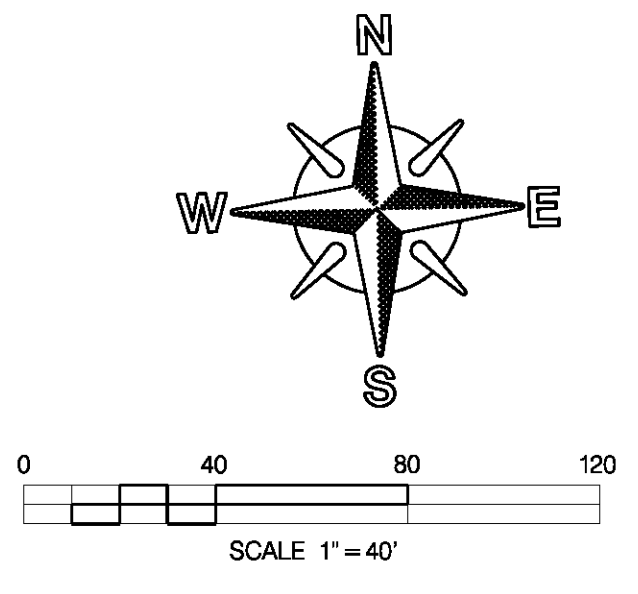
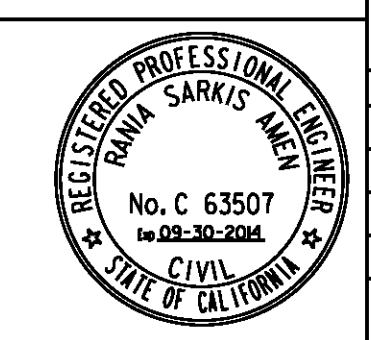

JUNIPER STREET

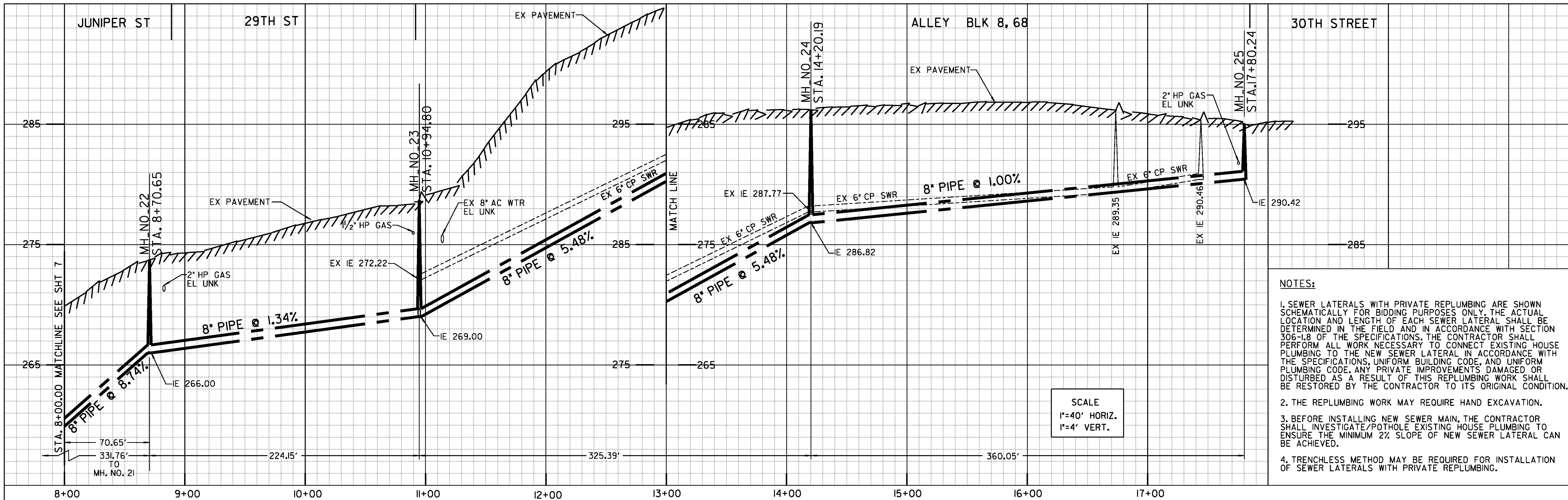

NOTES:

- SEWER LATERALS WITH PRIVATE REPLUMBING ARE SHOWN SCHEMATICALLY FOR BIDDING PURPOSES ONLY. THE ACTUAL LOCATION AND LENGTH OF EACH SEWER LATERAL SHALL BE DETERMINED IN THE FIELD AND IN ACCORDANCE WITH SECTION 306-I.8 OF THE SPECIFICATIONS. THE CONTRACTOR SHALL PERFORM ALL WORK NECESSARY TO CONNECT EXISTING HOUSE PLUMBING TO THE NEW SEWER LATERAL IN ACCORDANCE WITH THE SPECIFICATIONS, UNIFORM BUILDING CODE, AND UNIFORM PLUMBING CODE. ANY PRIVATE IMPROVEMENTS DAMAGED OR DISTURBED AS A RESULT OF THIS REPLUMBING WORK SHALL BE RESTORED BY THE CONTRACTOR TO ITS ORIGINAL CONDITION.
- THE REPLUMBING WORK MAY REQUIRE HAND EXCAVATION.
- BEFORE INSTALLING NEW SEWER MAIN, THE CONTRACTOR SHALL INVESTIGATE/POTHOLE EXISTING HOUSE PLUMBING TO ENSURE THE MINIMUM 2% SLOPE OF NEW SEWER LATERAL CAN BE ACHIEVED.
- TRENCHLESS METHOD MAY BE REQUIRED FOR INSTALLATION OF SEWER LATERALS WITH PRIVATE REPLUMBING.

SCALE
1"=40' HORIZ.
1"=4' VERT.

MAP 2258 - WRIGHT SUB UNIT NO.1
MAP 1746 - DELANO TCT.
ROS 14698

MH_NO_23
STA. 10+94.80
(122)

MAP 26
PARK ADD.

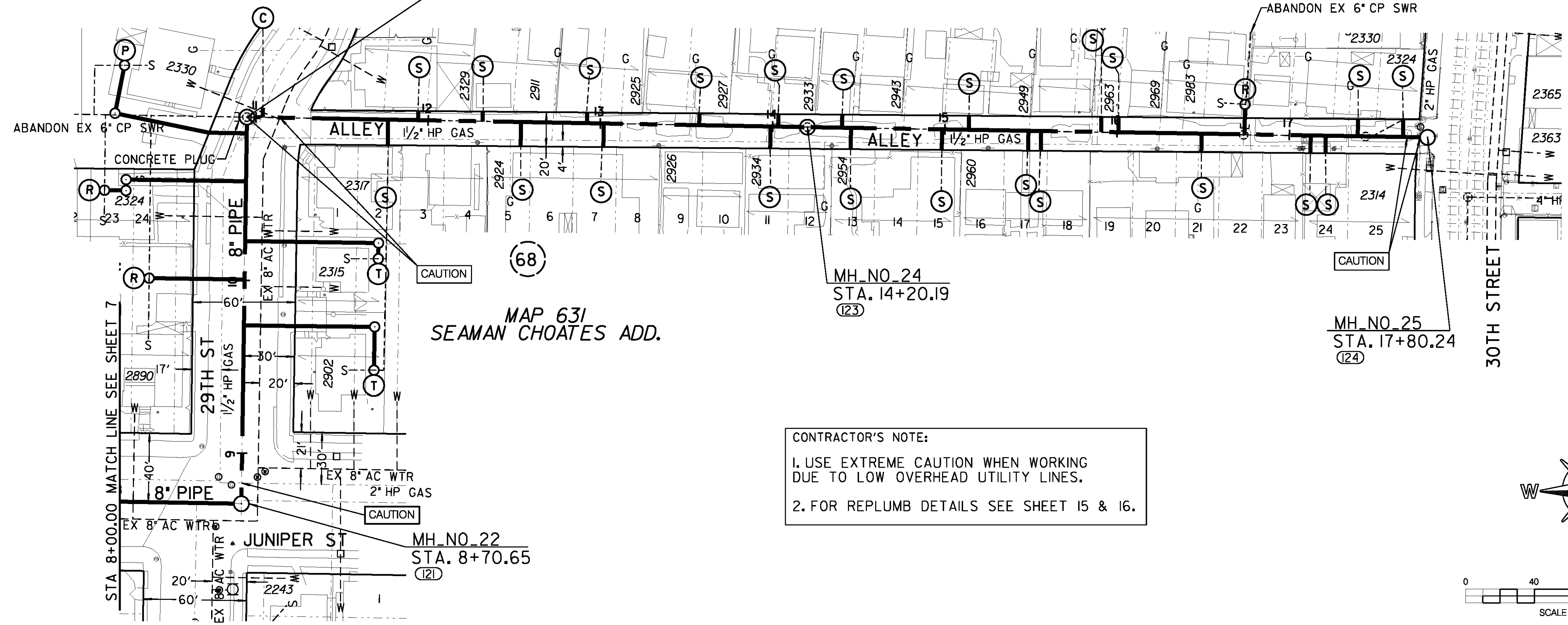

REFERENCE:

WATER: 16842-2-D
SEWER: 950-D
STORM DRAIN: NONE
GAS: 3-203
ELECTRIC: NONE
CABLE TV: 204-728
TELEPHONE: NONE
FIELD BOOK: H2OSC
100' SCALE: 202-1725,206-1725
THOMAS BROS.: 1289-EI

RETIREMENTS:

649.43' - 6" CP - 1940
MH - 4' X 3' - 4 - 1940
4" LATERAL - 28 - CP - 1940

CONTRACTOR'S NOTE:

- USE EXTREME CAUTION WHEN WORKING DUE TO LOW OVERHEAD UTILITY LINES.
- FOR REPLUMB DETAILS SEE SHEET 15 & 16.

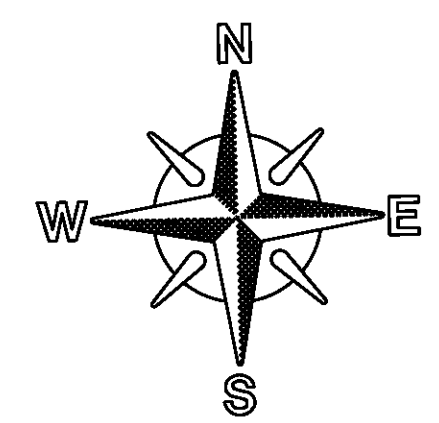

SEWER GROUP 691	
JUNIPER ST/29TH STREET WO 29TH ST TO NO ALLEY BLK 8, 68 ALLEY BLK 8, 68 29TH ST TO 30TH ST	
CITY OF SAN DIEGO, CALIFORNIA PUBLIC WORKS DEPARTMENT SHEET 08 OF 21 SHEETS	
APPROVED: <i>Rania Sarkis</i> FOR CITY ENGINEER RANIA AMEN DCE NAME	DATE: 7/14/2014
DESIGNED BY: JOSELITO GUINTO PROJECT ENGINEER	PROJECT MANAGER: JERICHO GALLARDO
DESCRIPTION: ORIGINAL	BY: JG/JG
APPROVED: []	DATE: []
FILED: []	DATE: []
No. C 63507 09-30-2014 CIVIL	
CONTRACTOR: [] DATE STARTED: []	
INSPECTOR: [] DATE COMPLETED: []	
207-1725 CCS27 COORDINATE 6286407-184244 CCS83 COORDINATE 32506-08-D	

C-7

JUNIPER ST/29TH ST & ALLEY BLK 8, 68



SCALE
1"=40' HORIZ.
1"=4' VERT.

1+00 2+00

NOTES:

1. SEWER LATERALS WITH PRIVATE REPLUMBING ARE SHOWN SCHEMATICALLY FOR BIDDING PURPOSES ONLY. THE ACTUAL LOCATION AND LENGTH OF EACH SEWER LATERAL SHALL BE DETERMINED IN THE FIELD AND IN ACCORDANCE WITH SECTION 306-L8 OF THE SPECIFICATIONS. THE CONTRACTOR SHALL PERFORM ALL WORK NECESSARY TO CONNECT EXISTING HOUSE PLUMBING TO THE NEW SEWER LATERAL IN ACCORDANCE WITH THE SPECIFICATIONS, UNIFORM BUILDING CODE, AND UNIFORM PLUMBING CODE. ANY PRIVATE IMPROVEMENTS DAMAGED OR DISTURBED AS A RESULT OF THIS REPLUMBING WORK SHALL BE RESTORED BY THE CONTRACTOR TO ITS ORIGINAL CONDITION.
2. THE REPLUMBING WORK MAY REQUIRE HAND EXCAVATION.
3. BEFORE INSTALLING NEW SEWER MAIN, THE CONTRACTOR SHALL INVESTIGATE/POTHOLE EXISTING HOUSE PLUMBING TO ENSURE THE MINIMUM 2% SLOPE OF NEW SEWER LATERAL CAN BE ACHIEVED.
4. TRENCHLESS METHOD MAY BE REQUIRED FOR INSTALLATION OF SEWER LATERALS WITH PRIVATE REPLUMBING.

MAP 631 - SEAMAN & CHOATES ADD.
MAP 236 - PARK ADD.
ROS 9645,14324

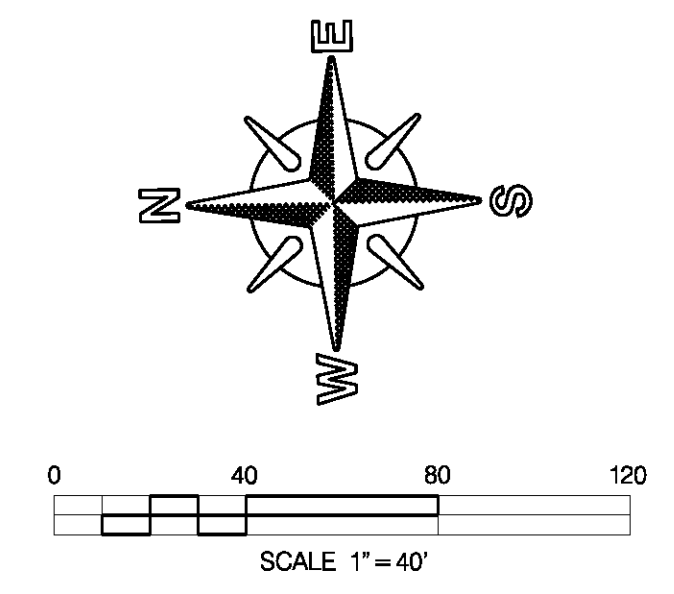
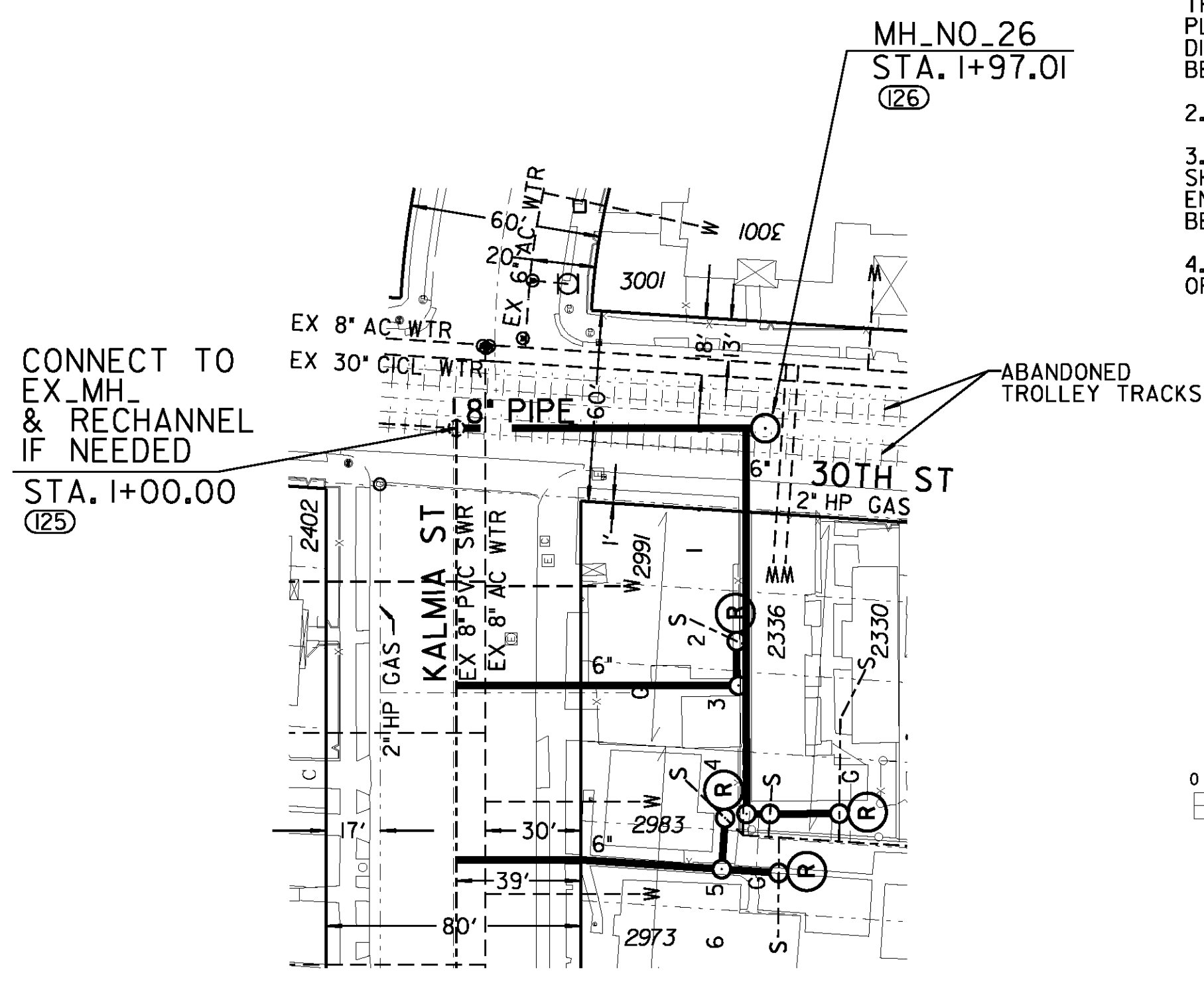

CONTRACTOR'S NOTE:
1. USE EXTREME CAUTION WHEN WORKING DUE TO LOW OVERHEAD UTILITY LINES.
2. FOR REPLUMB DETAILS SEE SHEET I5 & I6.

CONNECT TO EXIST. LATERAL
(NOT PART OF THIS CONTRACT)
REF. DWG NO. 27520-26-D

MAP 2258 - WRIGHT SUB UNIT NO.1
MAP 1746 - DELANO TCT.
ROS 14698

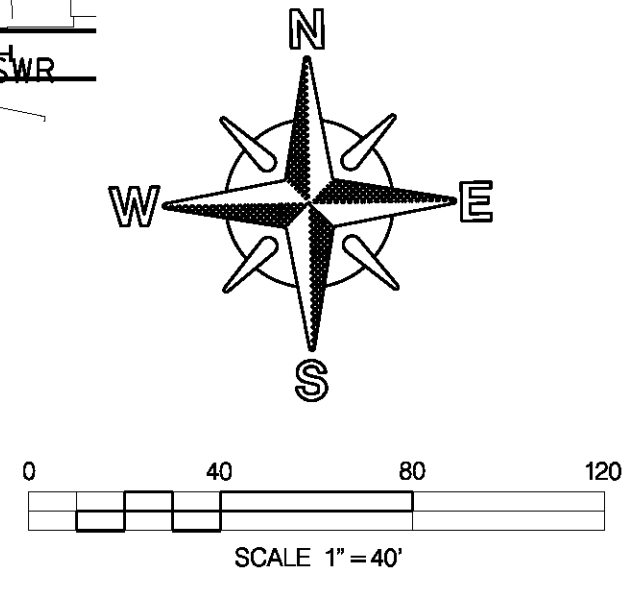
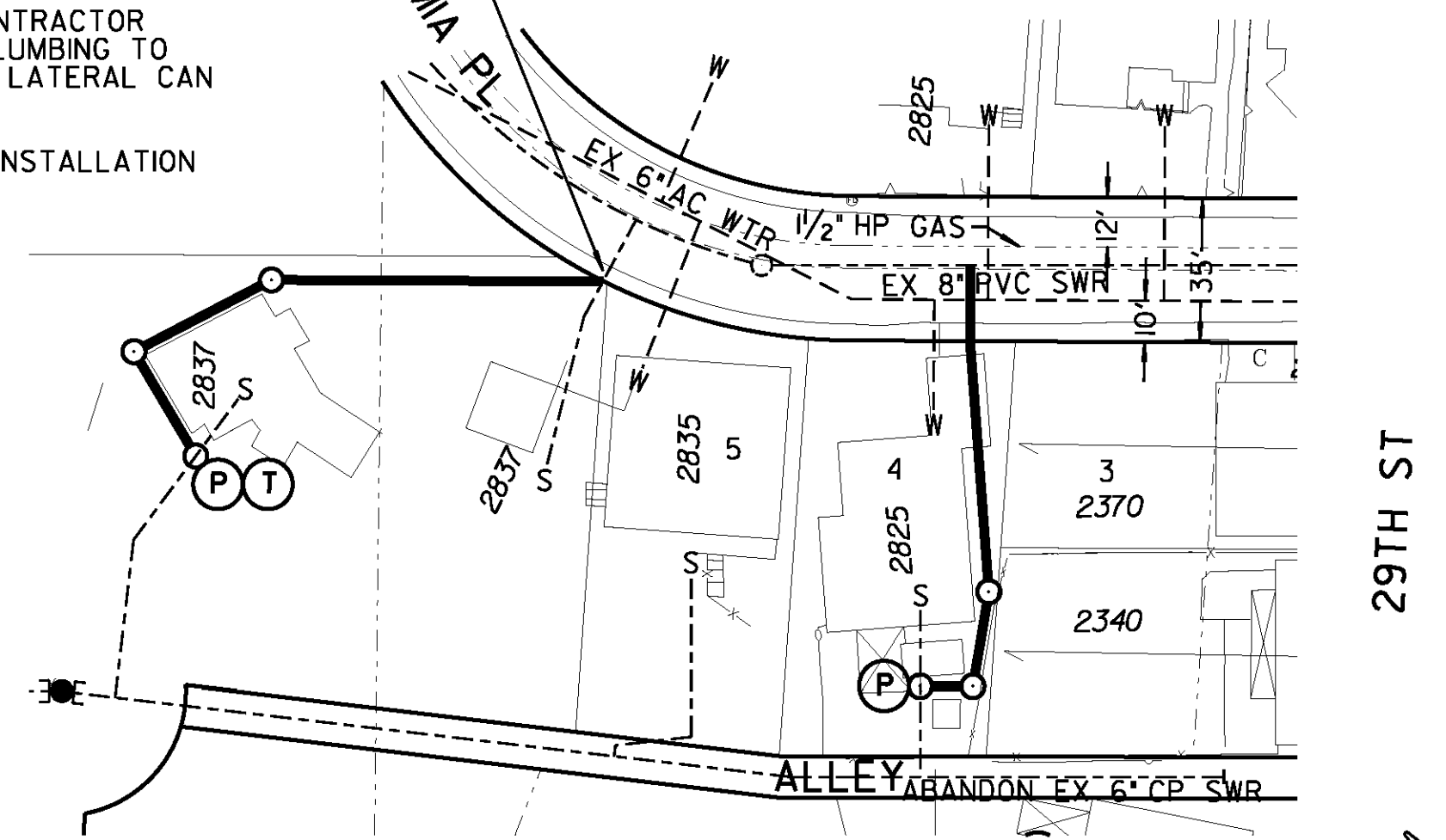

REFERENCE:

- WATER: 27520-35-D
- SEWER: 430-0-L, 27520-26-D
- STORM DRAIN: NONE
- GAS: 3-202
- ELECTRIC: NONE
- CABLE TV: 204-728
- TELEPHONE: NONE
- FIELD BOOK: H2OSC
- 100' SCALE: 206-1725
- THOMAS BROS.: I289-EI

RETIREMENTS:

- 282.71' - 6" CP - 1915
- 4" LATERAL - 6" - CP - 1915

SEWER GROUP 691 30TH STREET WO 30TH ST TO SO KALMIA ST KALMIA PL KALMIA PL TO 29TH STREET			
CITY OF SAN DIEGO, CALIFORNIA PUBLIC WORKS DEPARTMENT SHEET 09 OF 21 SHEETS		WATER WBS - SEWER WBS B-00446	
APPROVED: <i>Rania Amen</i> FOR CITY ENGINEER RANIA AMEN DATE 7/14/2014		DESIGNED BY: <i>Joelito Guinto</i> PROJECT MANAGER JOSELITO GUINTO	
DESCRIPTION	BY	APPROVED	DATE
ORIGINAL	JG/JG		
No. C 63507 09-30-2014		207-1725 CCS27 COORDINATE	
6286407-184244 CCS83 COORDINATE		207-1725 CCS27 COORDINATE	
CONTRACTOR		DATE STARTED	
INSPECTOR		DATE COMPLETED	
		32506-09-D	

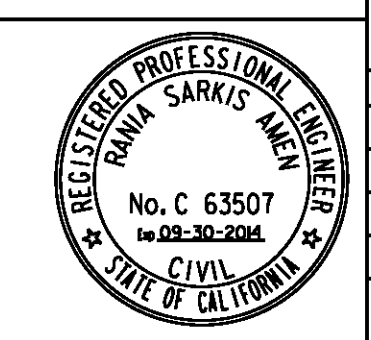

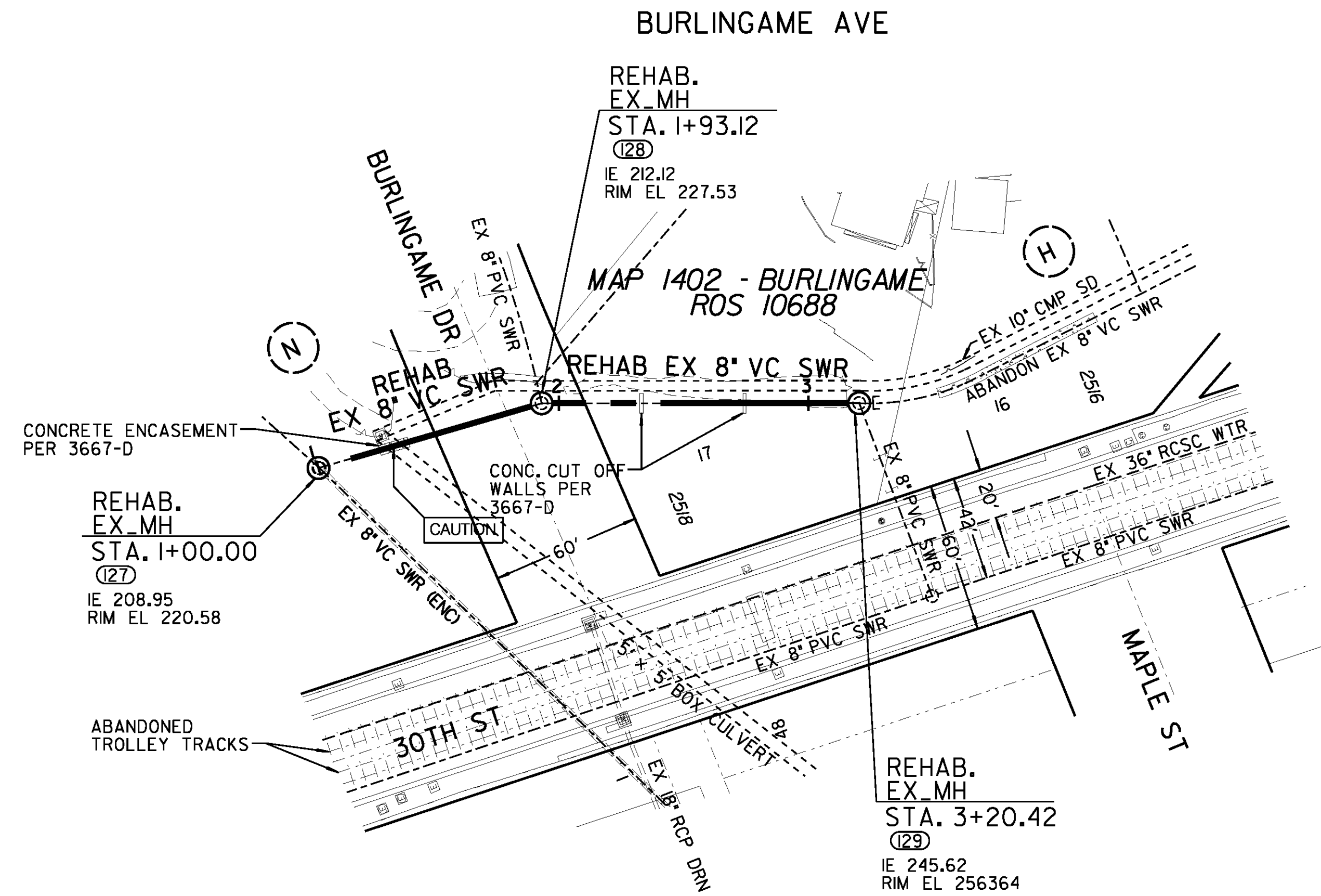

REFERENCE:

WATER: I2870-9-D
 SEWER: 29665-2-D, 3667-D
 STORM DRAIN: 3666-D
 GAS: NONE
 ELECTRIC: NONE
 CABLE TV: 204-728
 TELEPHONE: NONE
 FIELD BOOK: H20SC
 100' SCALE: 206-1725
 THOMAS BROS.: I269-E7

RETIREMENTS:

220.42' - 8" VC - 1956
 MH - 4' X 3' - 3 - 1956

C-09

SEWER GROUP 691				
EASEMENT BLK H, N				
NO BURLINGAME DR TO MAPLE ST				
CITY OF SAN DIEGO, CALIFORNIA PUBLIC WORKS DEPARTMENT SHEET 10 OF 21 SHEETS				WATER WBS -
APPROVED BY: <i>[Signature]</i> FOR CITY ENGINEER RANIA AMEN DCE NAME				SEWER WBS B-00446
DATE: 7/14/2014				DESIGNED BY: JERICHO GALLARDO PROJECT MANAGER
CHECKED BY: JOSELITO QUINTO PROJECT ENGINEER				
DESCRIPTION	BY	APPROVED	DATE	FILMED
ORIGINAL	JG/JG			
				207-1725
				CCS27 COORDINATE
				6286407-184244
				CCS83 COORDINATE
CONTRACTOR		DATE STARTED		
INSPECTOR		DATE COMPLETED		
32506-10-D				

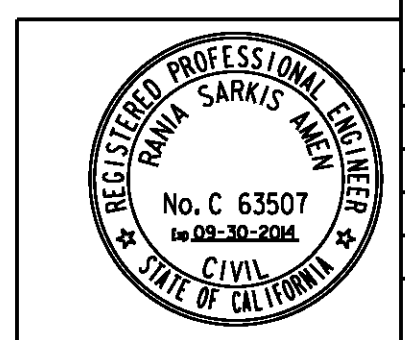
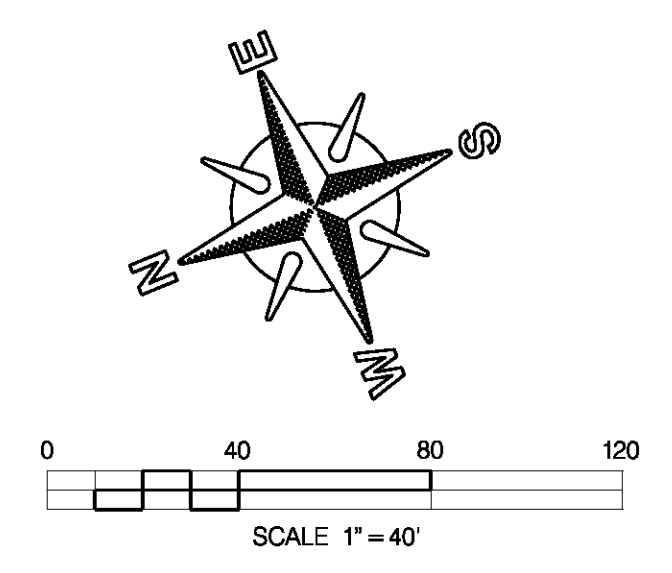

EASEMENT BLK H, N

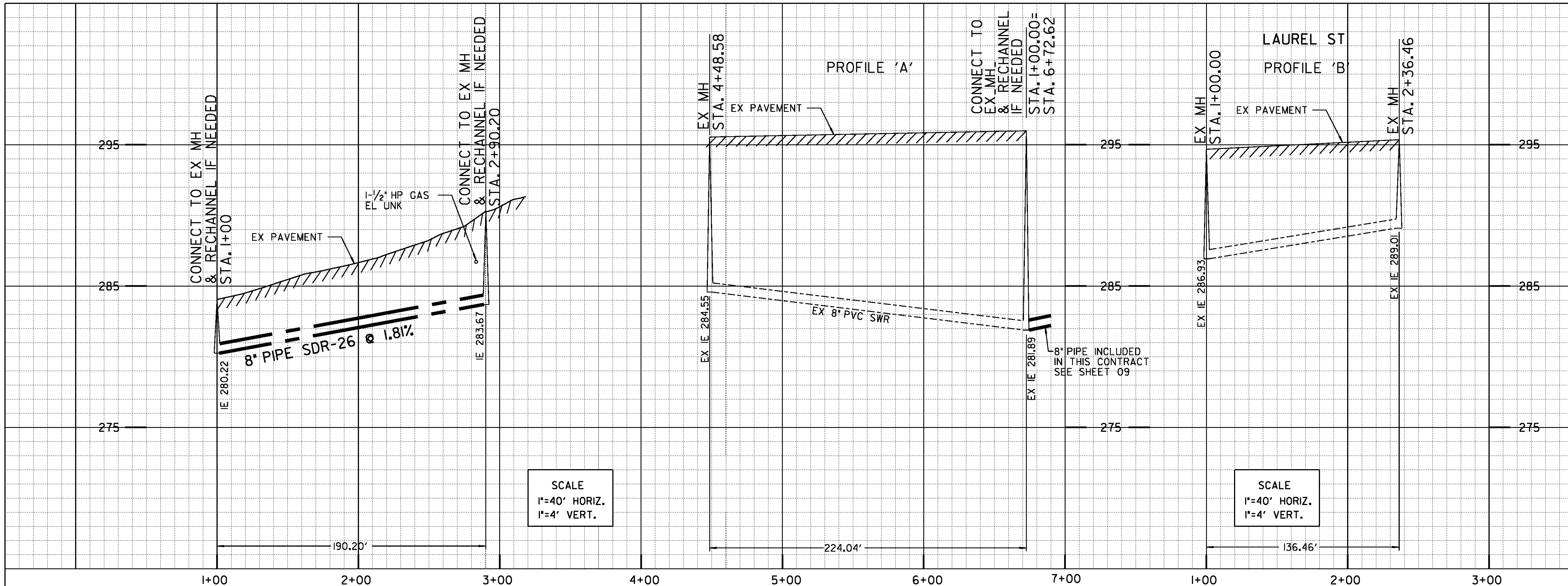

- NOTES:**
- SEWER LATERALS WITH PRIVATE REPLUMBING ARE SHOWN SCHEMATICALLY FOR BIDDING PURPOSES ONLY. THE ACTUAL LOCATION AND LENGTH OF EACH SEWER LATERAL SHALL BE DETERMINED IN THE FIELD AND IN ACCORDANCE WITH SECTION 306-1.8 OF THE SPECIFICATIONS. THE CONTRACTOR SHALL PERFORM ALL WORK NECESSARY TO CONNECT EXISTING HOUSE PLUMBING TO THE NEW SEWER LATERAL IN ACCORDANCE WITH THE SPECIFICATIONS, UNIFORM BUILDING CODE, AND UNIFORM PLUMBING CODE. ANY PRIVATE IMPROVEMENTS DAMAGED OR DISTURBED AS A RESULT OF THIS REPLUMBING WORK SHALL BE RESTORED BY THE CONTRACTOR TO ITS ORIGINAL CONDITION.
 - THE REPLUMBING WORK MAY REQUIRE HAND EXCAVATION.
 - BEFORE INSTALLING NEW SEWER MAIN, THE CONTRACTOR SHALL INVESTIGATE/POTHOLE EXISTING HOUSE PLUMBING TO ENSURE THE MINIMUM 2% SLOPE OF NEW SEWER LATERAL CAN BE ACHIEVED.
 - TRENCHLESS METHOD MAY BE REQUIRED FOR INSTALLATION OF SEWER LATERALS WITH PRIVATE REPLUMBING.
 - IF REQUIRED, THE CONTRACTOR SHALL REMOVE AND DISPOSE OF ABANDONED TROLLEY TRACKS FOR INSTALLATION OF NEW SEWER MAIN AND LATERALS AT NO ADDITIONAL COST TO THE CITY.
 - THE CONTRACTOR SHALL DUPLICATE THE EXISTING SURROUNDINGS CORE PATTERN AND ROSE COLORED CONCRETE SIDEWALKS, CURBS, AND DRIVEWAYS PER SECTION 303-5.1.5 OF THE SPECIFICATIONS.
 - FOR REPLUMB DETAILS SEE SHEET 18 & 19.

SCALE
1"=40' HORIZ.
1"=4' VERT.

SCALE
1"=40' HORIZ.
1"=4' VERT.

REFERENCE:

- WATER: 6478-W, 27520-36-D, 20055-D
- SEWER: 84-0, 27520-21-D, 27520-25-D, 27520-26 D, 25765-7-D
- STORM DRAIN: 206-1728
- GAS: 3-201G
- ELECTRIC: NONE
- CABLE TV: 204-728
- TELEPHONE:
- FIELD BOOK H20SC
- 100' SCALE: 206-1725
- THOMAS BROS.: 1289-EI

RETIREMENTS:

- 164.00' - 6' VC - 1956
- 4' LATERAL - 9 - VC - 1956

C-10

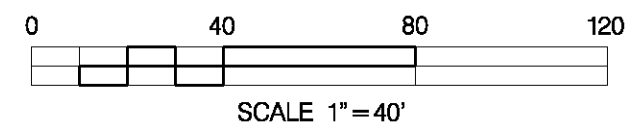
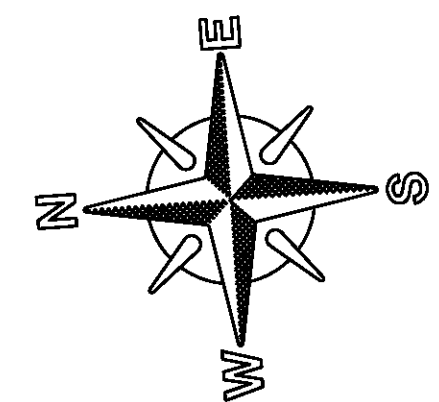
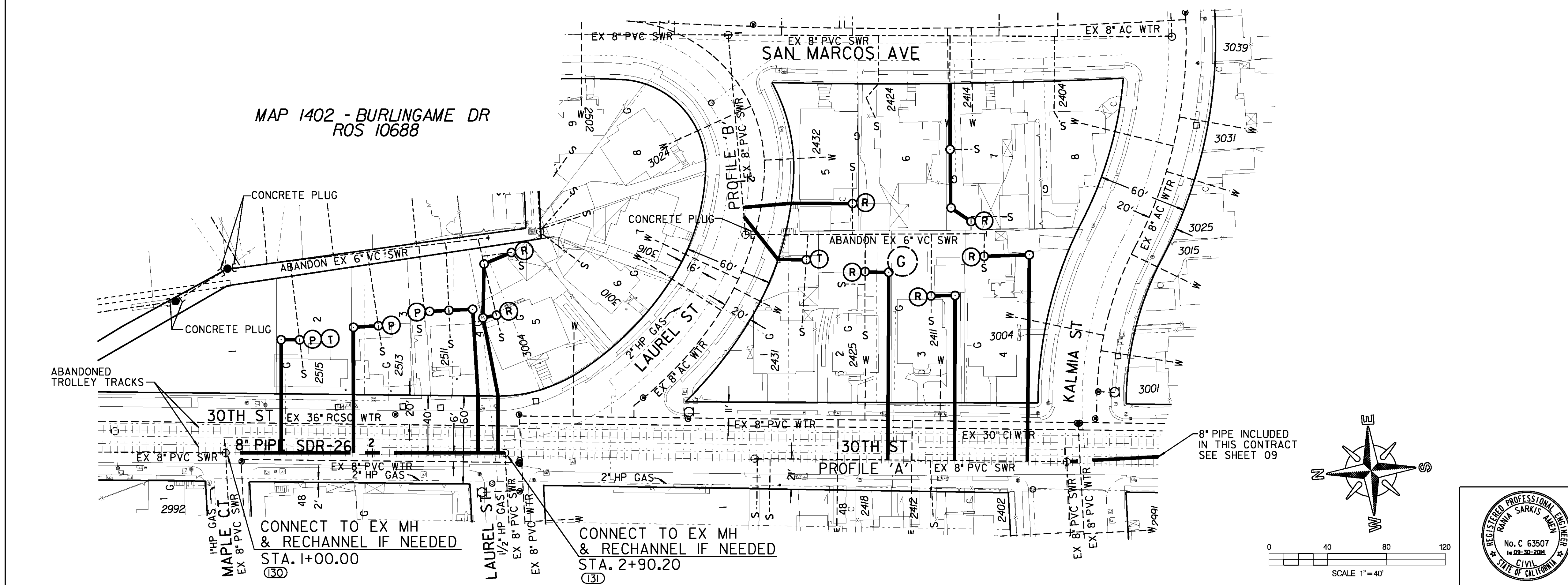

SEWER GROUP 691 30TH STREET MAPLE CT TO LAUREL ST LAUREL STREET 30TH ST TO SAN MARCOS AVE				WATER WBS SEWER WBS B-00446
CITY OF SAN DIEGO, CALIFORNIA PUBLIC WORKS DEPARTMENT SHEET 11 OF 21 SHEETS		DATE 7/14/2014	PROJECT MANAGER JERICO GALLARDO	
FOR CITY ENGINEER RANIA AMEN DCE NAME		CHECKED BY JOSELITO QUINTO PROJECT ENGINEER		
DESCRIPTION ORIGINAL	BY JG/JG	APPROVED	DATE	FILMED
CONTRACTOR		DATE STARTED		207-1725 CCS27 COORDINATE 6286407-184244 CCS88 COORDINATE
INSPECTOR		DATE COMPLETED		32506-11-D

30TH STREET / LAUREL STREET

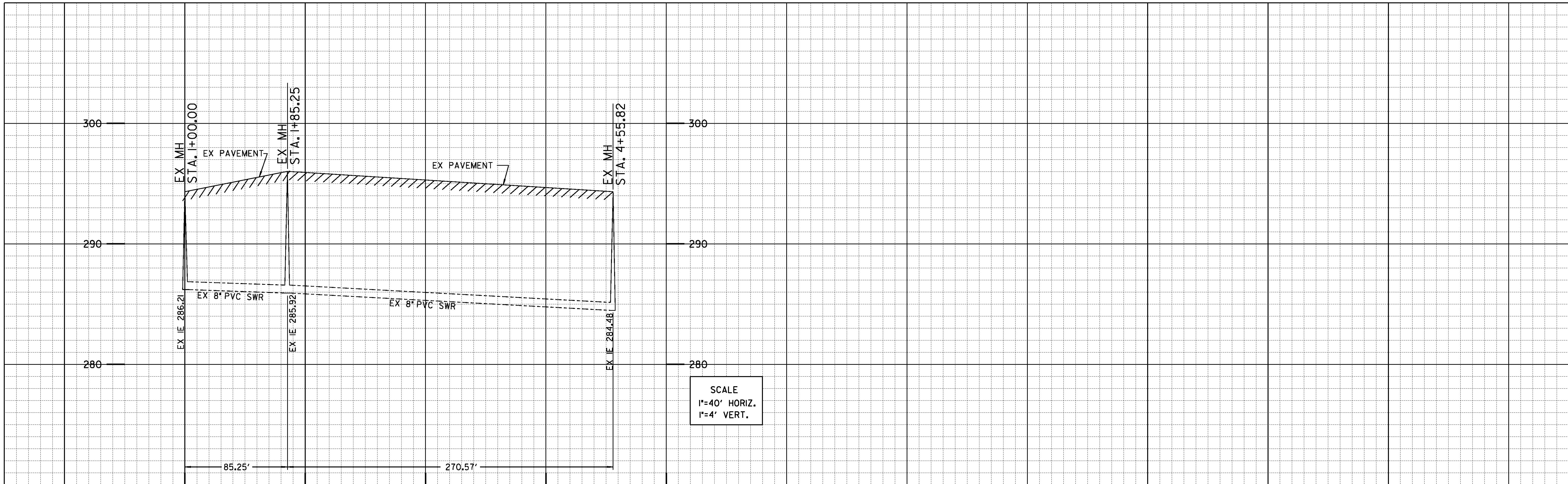

SCALE
1"=40' HORIZ.
1"=4' VERT.

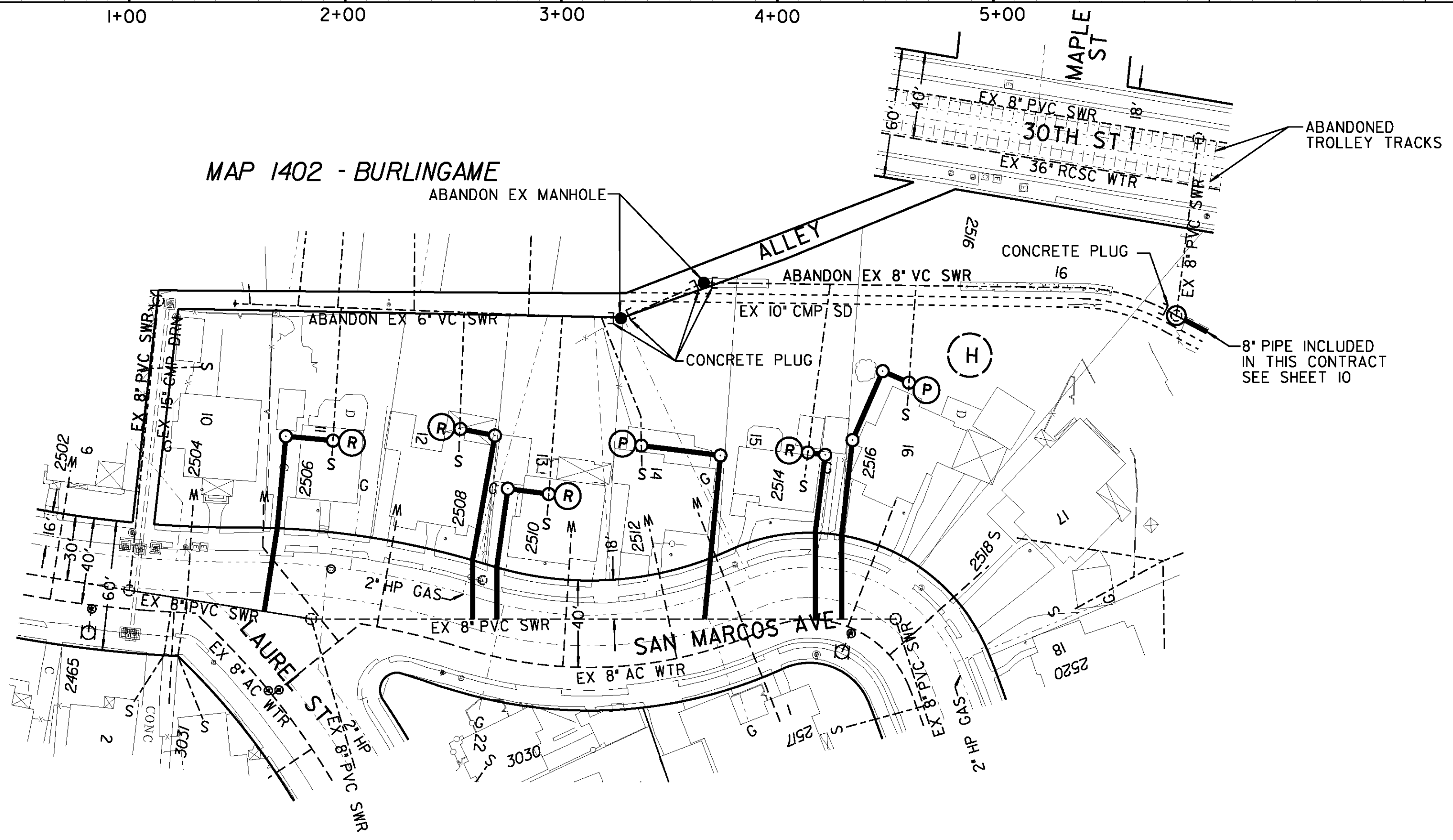

- NOTES:**
- SEWER LATERALS WITH PRIVATE REPLUMBING ARE SHOWN SCHEMATICALLY FOR BIDDING PURPOSES ONLY. THE ACTUAL LOCATION AND LENGTH OF EACH SEWER LATERAL SHALL BE DETERMINED IN THE FIELD AND IN ACCORDANCE WITH SECTION 306-I.8 OF THE SPECIFICATIONS. THE CONTRACTOR SHALL PERFORM ALL WORK NECESSARY TO CONNECT EXISTING HOUSE PLUMBING TO THE NEW SEWER LATERAL IN ACCORDANCE WITH THE SPECIFICATIONS, UNIFORM BUILDING CODE, AND UNIFORM PLUMBING CODE. ANY PRIVATE IMPROVEMENTS DAMAGED OR DISTURBED AS A RESULT OF THIS REPLUMBING WORK SHALL BE RESTORED BY THE CONTRACTOR TO ITS ORIGINAL CONDITION.
 - THE REPLUMBING WORK MAY REQUIRE HAND EXCAVATION.
 - BEFORE INSTALLING NEW SEWER MAIN, THE CONTRACTOR SHALL INVESTIGATE/POTHOLE EXISTING HOUSE PLUMBING TO ENSURE THE MINIMUM 2% SLOPE OF NEW SEWER LATERAL CAN BE ACHIEVED.
 - TRENCHLESS METHOD MAY BE REQUIRED FOR INSTALLATION OF SEWER LATERALS WITH PRIVATE REPLUMBING.
 - THE CONTRACTOR SHALL DUPLICATE THE EXISTING SURROUNDING SCORE PATTERN AND ROSE-COLORED CONCRETE SIDEWALKS, CURBS AND DRIVEWAYS PER SECTION 303-5.1.5 OF THE SPECIFICATIONS.
 - FOR REPLUMB DETAILS SEE SHEET 18.

REFERENCE:

WATER: I2870-8-D, I2870-6-D, I2870-7-D
 SEWER: DWO 19078
 STORM DRAIN: 206-I728
 GAS: 3-201C
 ELECTRIC: NONE
 CABLE TV: 204-728
 TELEPHONE: NONE
 FIELD BOOK: H205C
 100' SCALE: 206-I725
 THOMAS BROS. I289-EI, I269-E7

RETIREMENTS:

220.50' - 6" VC - 1956
 221.10' - 8" VC - 1956
 MH - 4' X 3' - 2 - 1956
 4" LATERAL - 6" VC - 1956

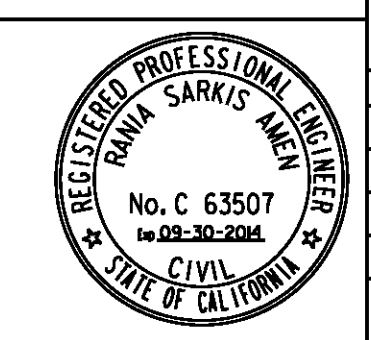
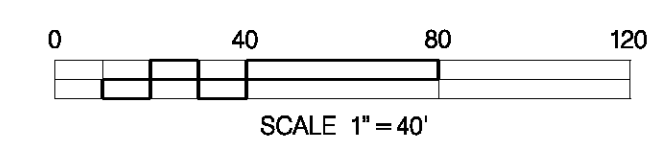
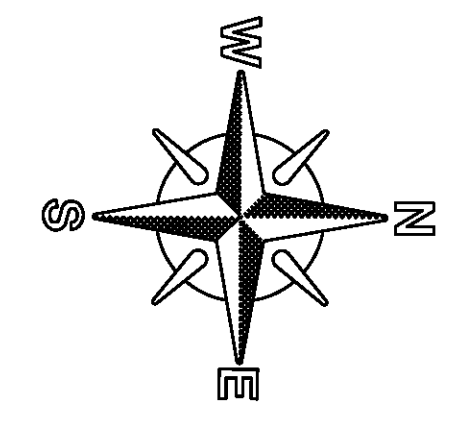

C-11

SEWER GROUP 691				
SAN MARCOS AVE				
LAUREL ST TO SAN MARCOS AVE				
CITY OF SAN DIEGO, CALIFORNIA PUBLIC WORKS DEPARTMENT SHEET 12 OF 21 SHEETS			WATER WBS - SEWER WBS B-00446	
APPROVED BY: <i>Rania Sarkis</i> FOR CITY ENGINEER RANIA AMEN DCE NAME		DATE 7/14/2014		DESIGNED BY: JERICHO GALLARDO PROJECT MANAGER
DESCRIPTION		BY	APPROVED	DATE
ORIGINAL	JG/JG			
CHECKED BY: JOSELITO GUINTO PROJECT ENGINEER				
207-1725				
CCS27 COORDINATE				
6286407-184244				
CCS83 COORDINATE				
CONTRACTOR		DATE STARTED		
INSPECTOR		DATE COMPLETED		
32506-12-D				

SAN MARCOS AVE

FOR THE ABANDONMENT OF SEWER MAIN AND MANHOLE ON BALBOA PARK MUNICIPAL GOLF COURSE, THE CONTRACTOR SHALL COORDINATE ACCESS TO THE SITE AND DETERMINE TOURNAMENTS AND EVENTS SCHEDULE BY CONTACTING PAUL CUSHING AT (858) 552-1606.

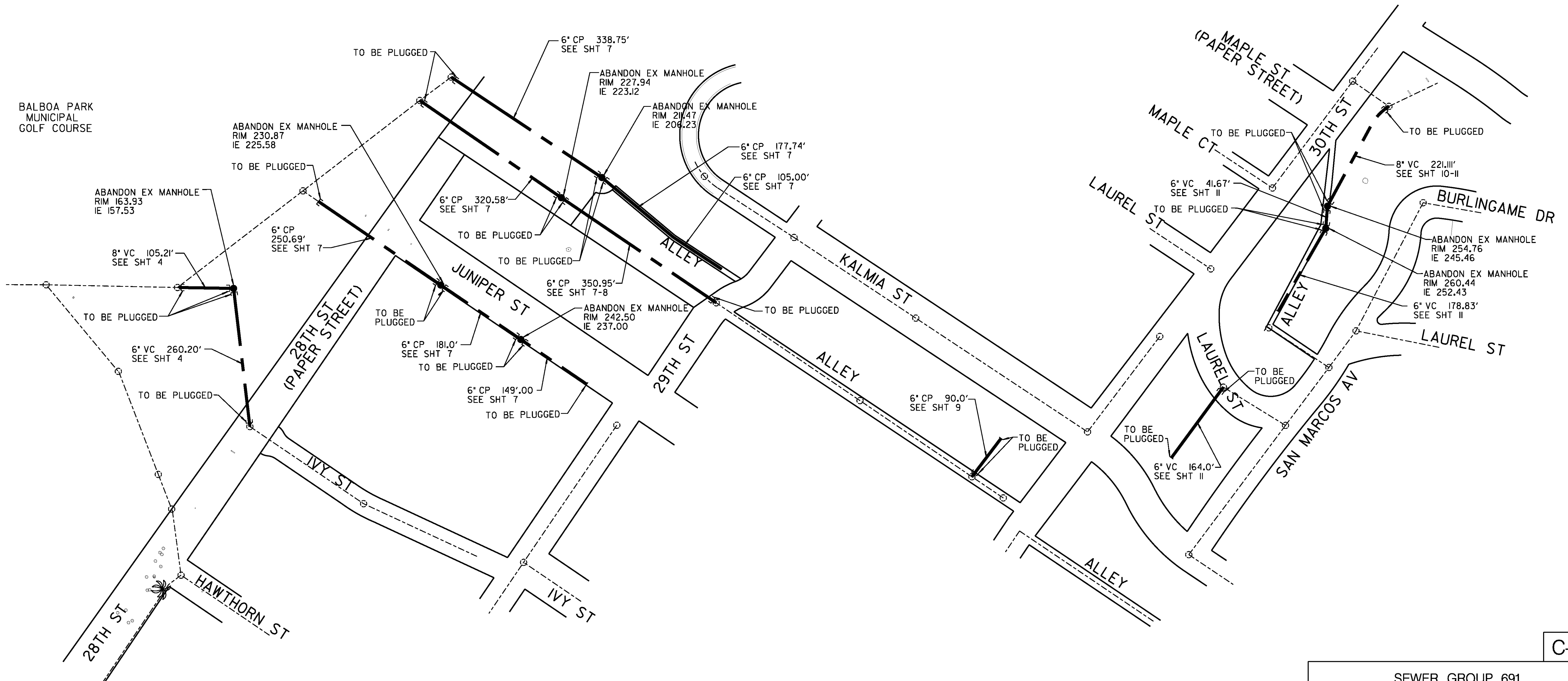

C-12

SEWER GROUP 691
SEWER ABANDONMENT SHEET

CITY OF SAN DIEGO, CALIFORNIA PUBLIC WORKS DEPARTMENT SHEET 13 OF 21 SHEETS		WATER WBS - SEWER WBS B-00446		
APPROVED BY <i>Rania Amen</i> FOR CITY ENGINEER RANIA AMEN DCE NAME	DATE 7/14/2014	DESIGNED BY JERICHO GALLARDO PROJECT MANAGER CHECKED BY JOSELITO GUINTO PROJECT ENGINEER		
DESCRIPTION	BY	APPROVED	DATE	FILMED
ORIGINAL	JG/JG			
CONTRACTOR		DATE STARTED		CCS27 COORDINATE
INSPECTOR		DATE COMPLETED		CCS83 COORDINATE
				32506-13-D

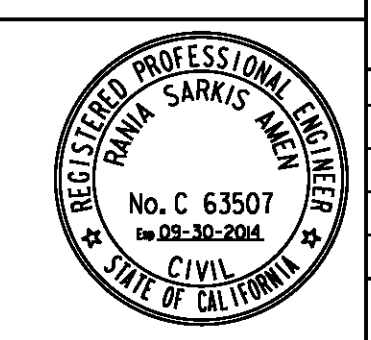
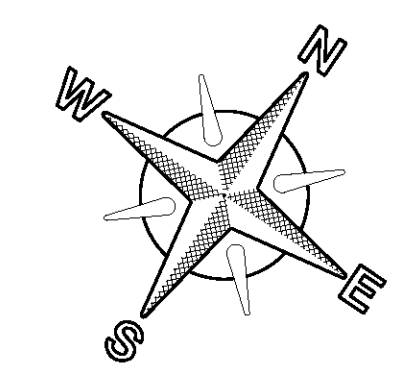

NO SCALE

SEWER ABANDONMENT SHEET

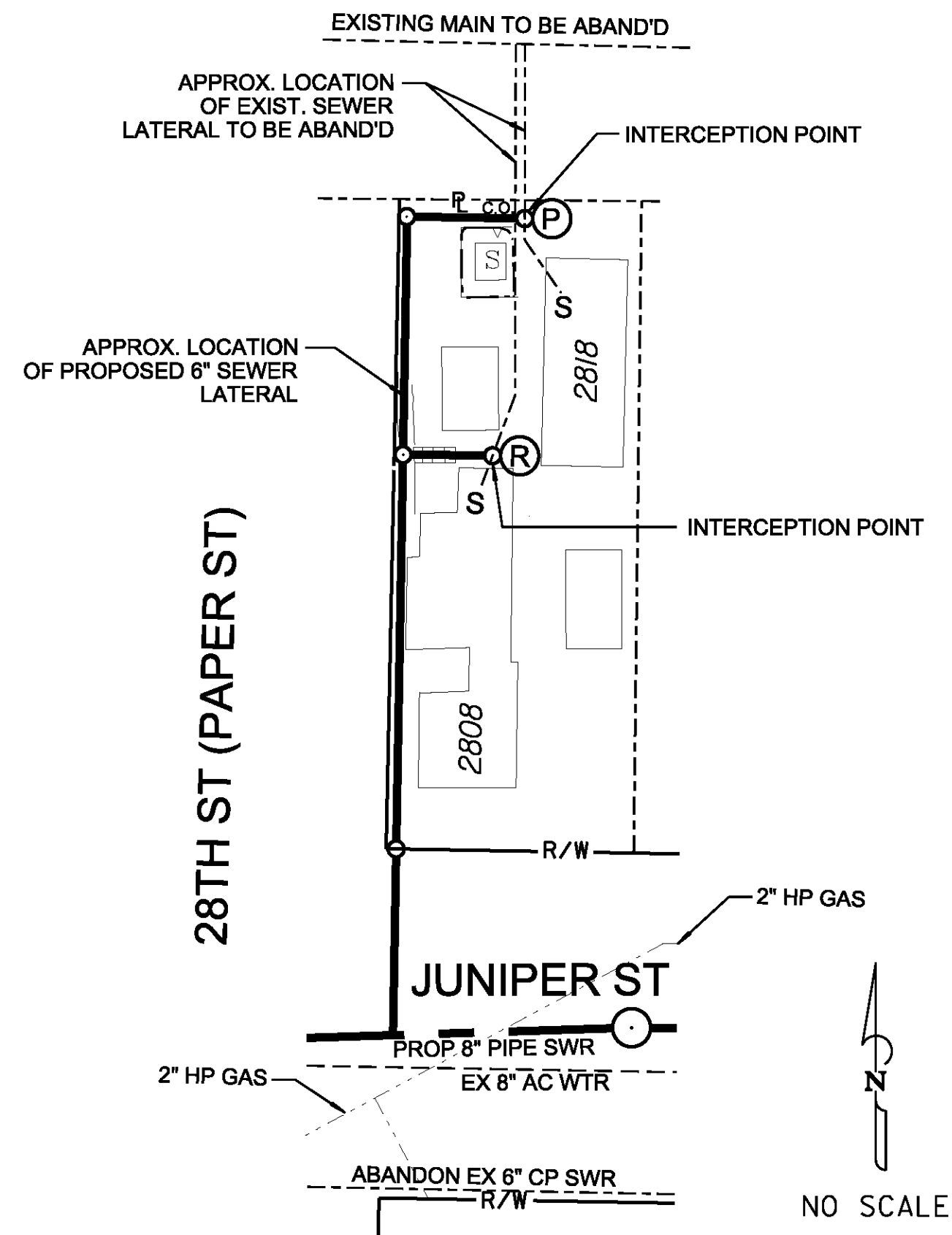

SEWER LATERAL REPLUMB WORK
ADDRESS: 2808 & 2818 JUNIPER ST
SEE SHEET 07

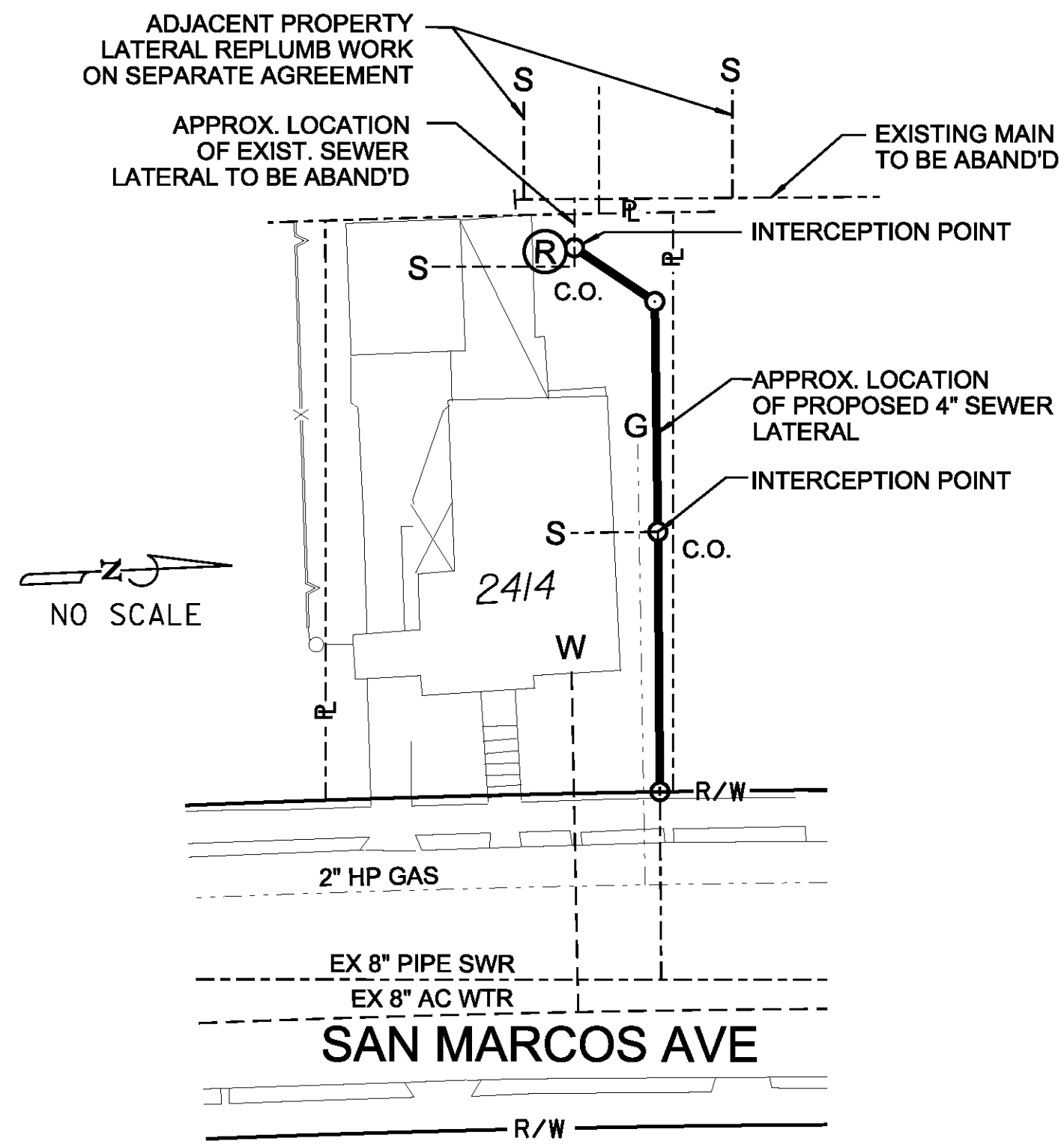

SEWER LATERAL REPLUMB WORK
ADDRESS: 2414 SAN MARCOS AVE
SEE SHEET II

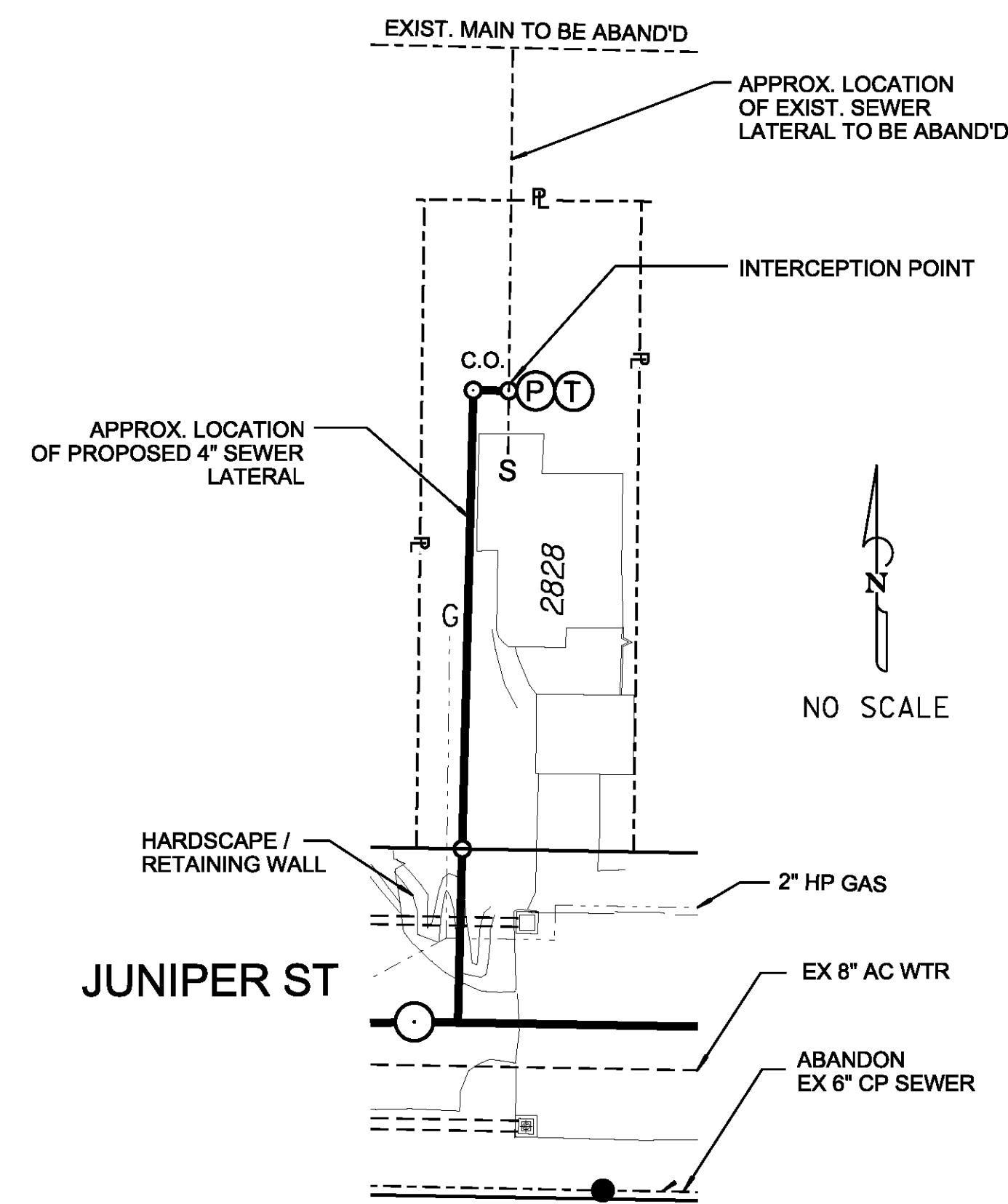

SEWER LATERAL REPLUMB WORK
ADDRESS: 2828 JUNIPER ST
SEE SHEET 07

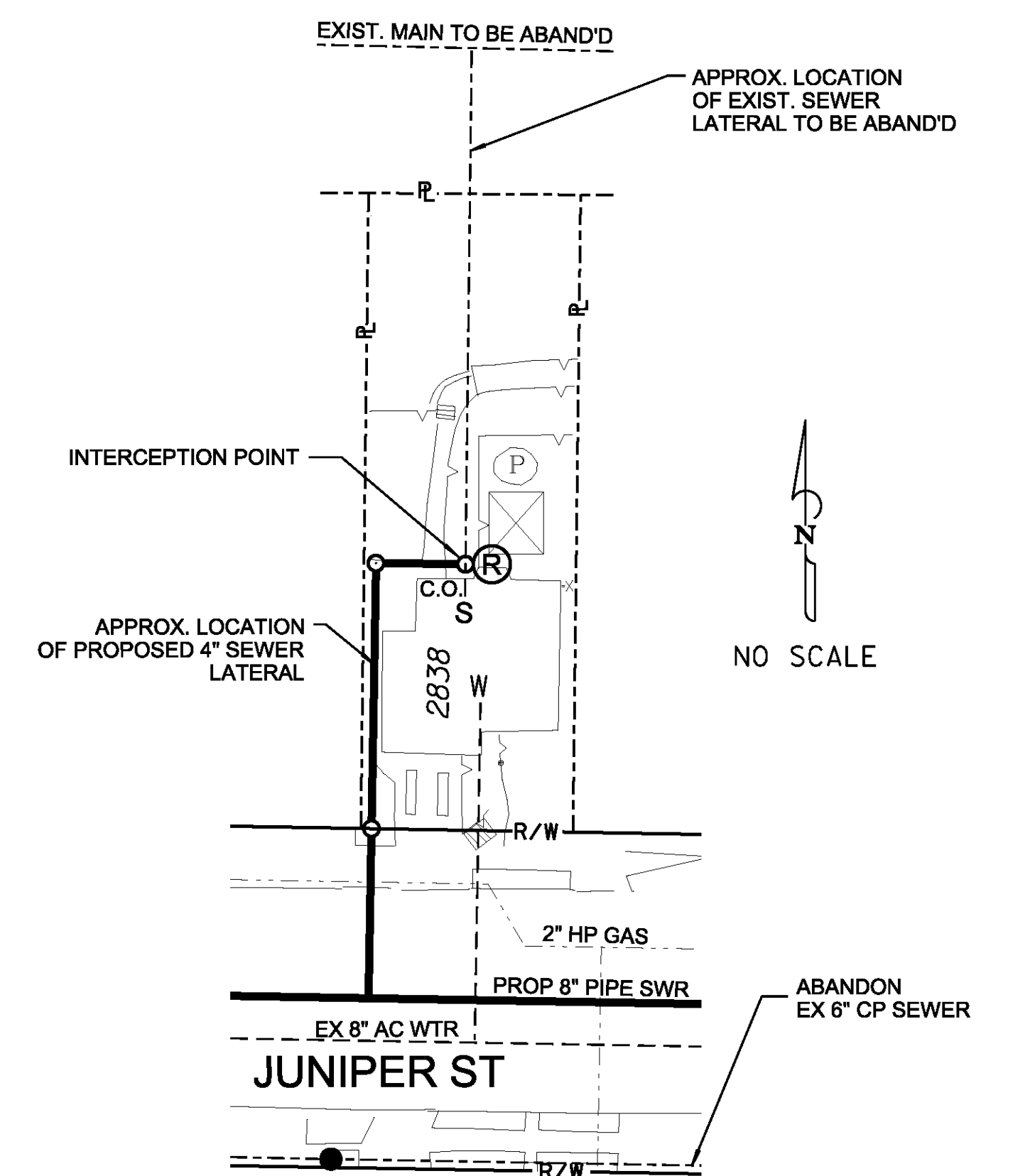

SEWER LATERAL REPLUMB WORK
ADDRESS: 2838 JUNIPER ST
SEE SHEET 07

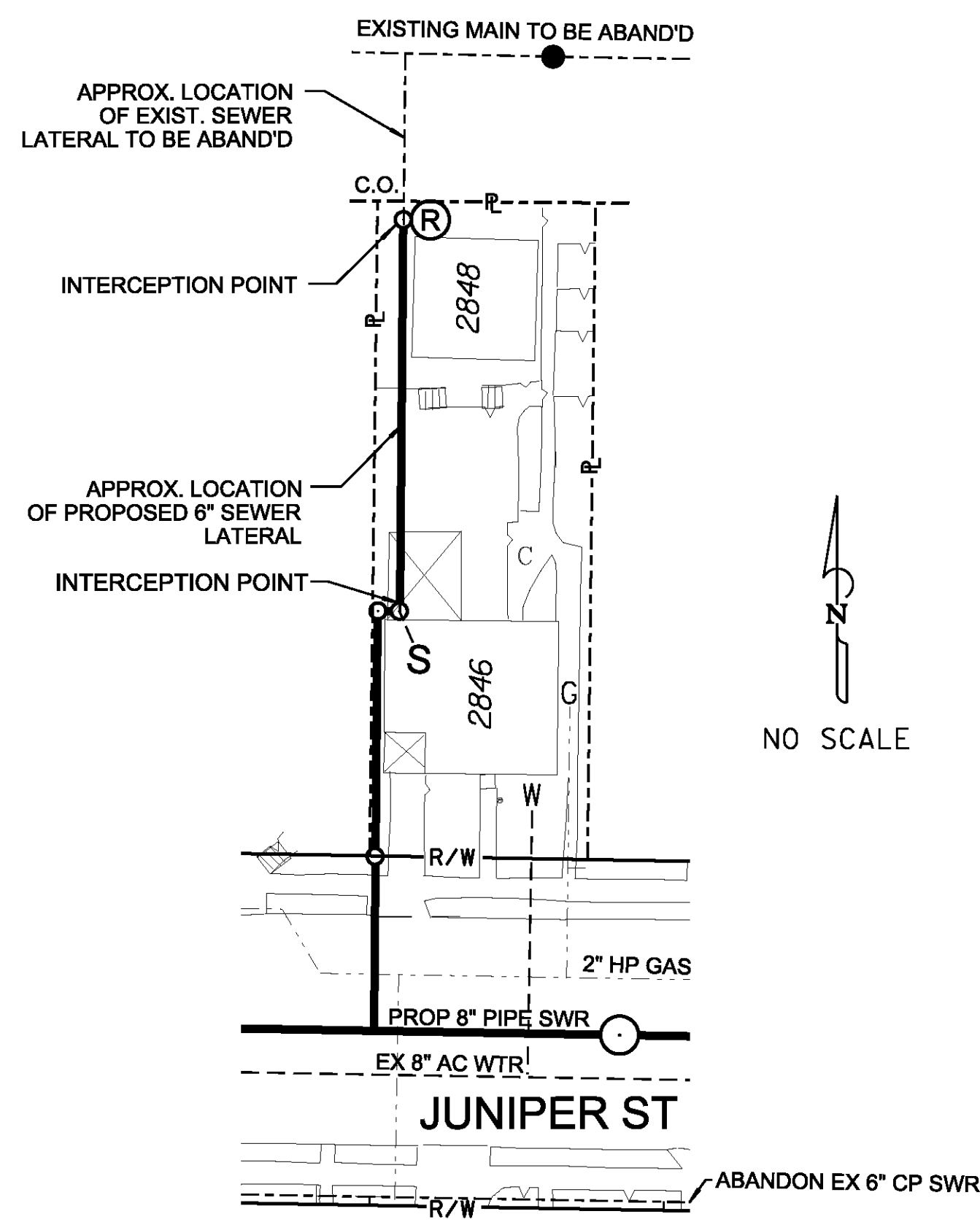

SEWER LATERAL REPLUMB WORK
ADDRESS: 2846-2848 JUNIPER ST
SEE SHEET 07

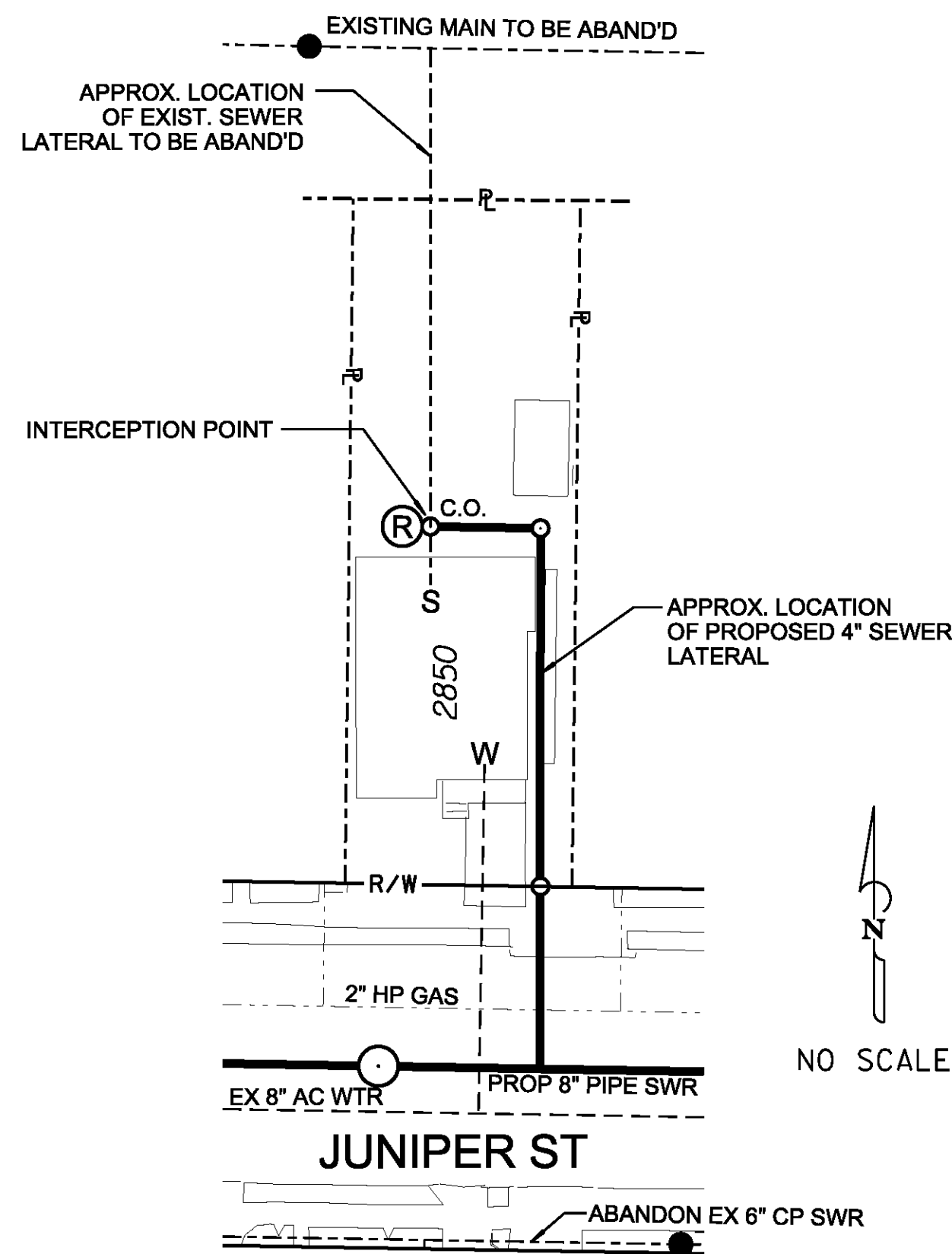

SEWER LATERAL REPLUMB WORK
ADDRESS: 2850 JUNIPER ST
SEE SHEET 07

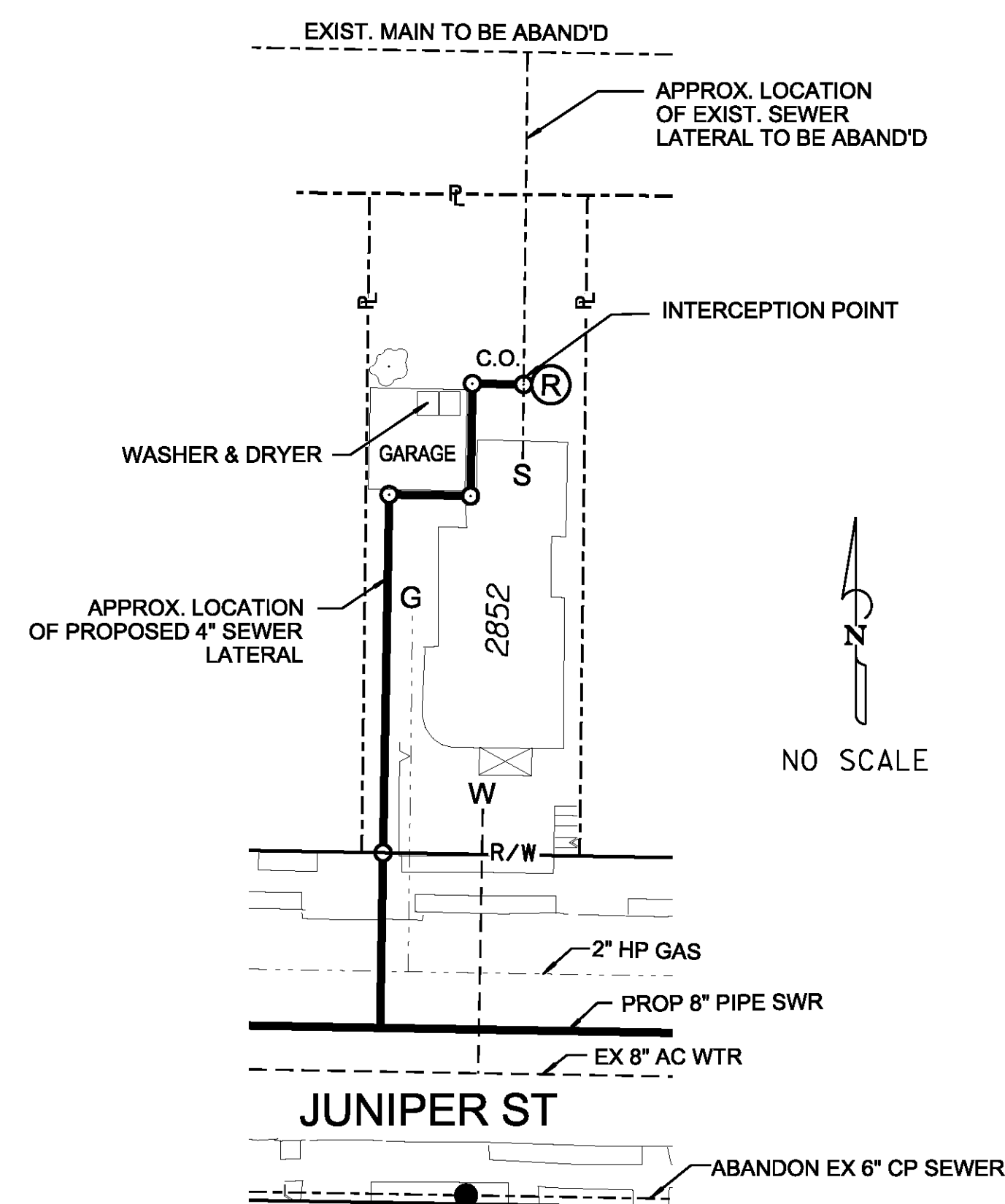

SEWER LATERAL REPLUMB WORK
ADDRESS: 2852 JUNIPER ST
SEE SHEET 07

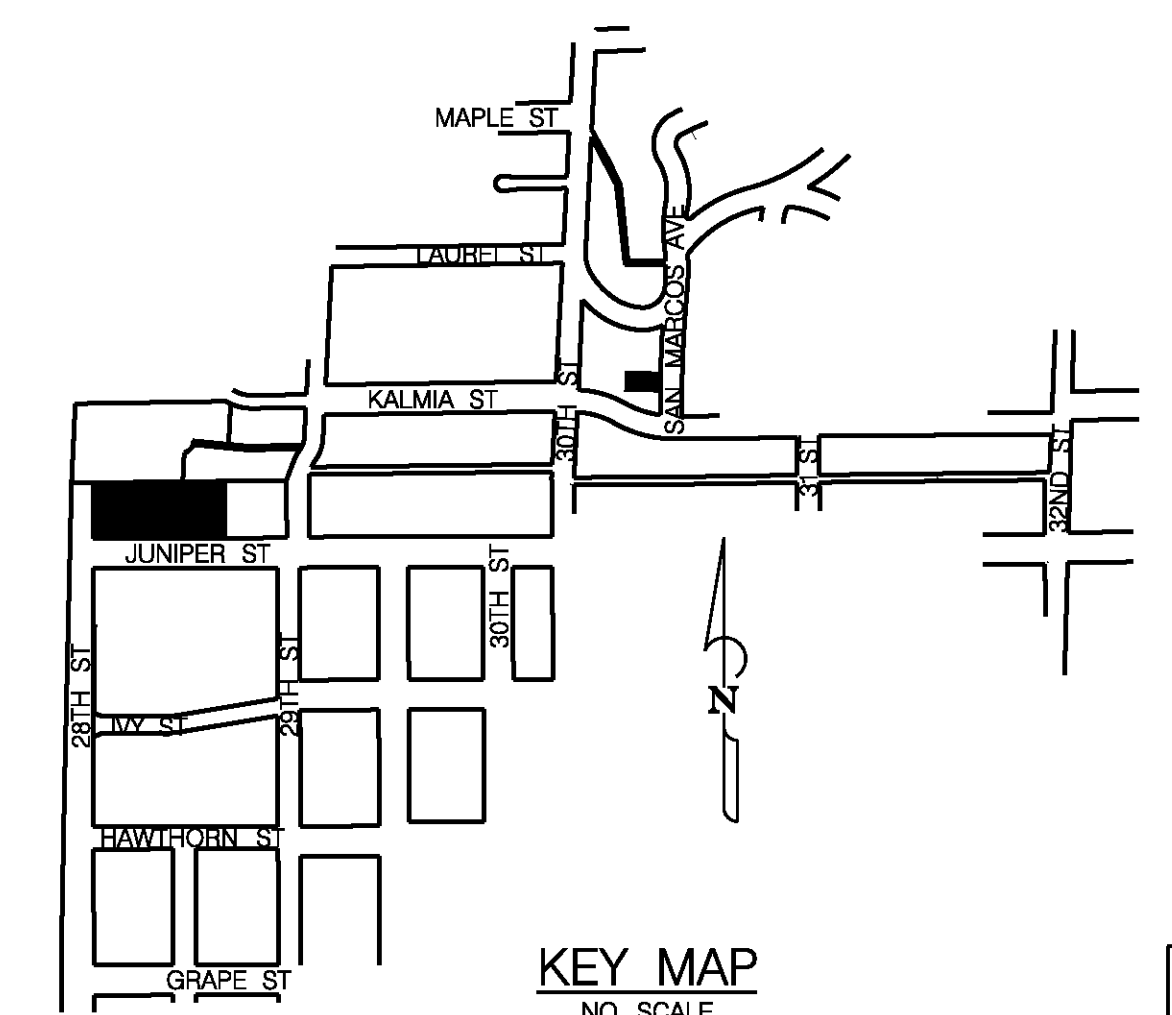

KEY MAP
NO SCALE

C-13

SEWER GROUP 691
REPLUMB DETAILS

CITY OF SAN DIEGO, CALIFORNIA PUBLIC WORKS DEPARTMENT SHEET 14 OF 21 SHEETS		WATER WBS -	SEWER WBS B-00446
APPROVED BY: <i>Rania Amen</i> FOR CITY ENGINEER RANIA AMEN DATE: 7/14/2014		PROJECT MANAGER JERICHO GALLARDO	
DCE NAME		PROJECT ENGINEER JOSELITO QUINTO	
DESCRIPTION	BY	APPROVED	DATE
ORIGINAL	JG/JG		
CONTRACTOR		DATE STARTED	
INSPECTOR		DATE COMPLETED	
SEE EACH SHEET CC527 COORDINATE		SEE EACH SHEET CC583 COORDINATE	
		32506-14-D	

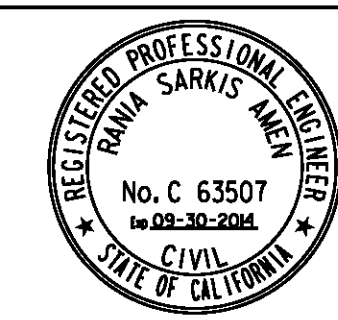

REPLUMB DETAILS

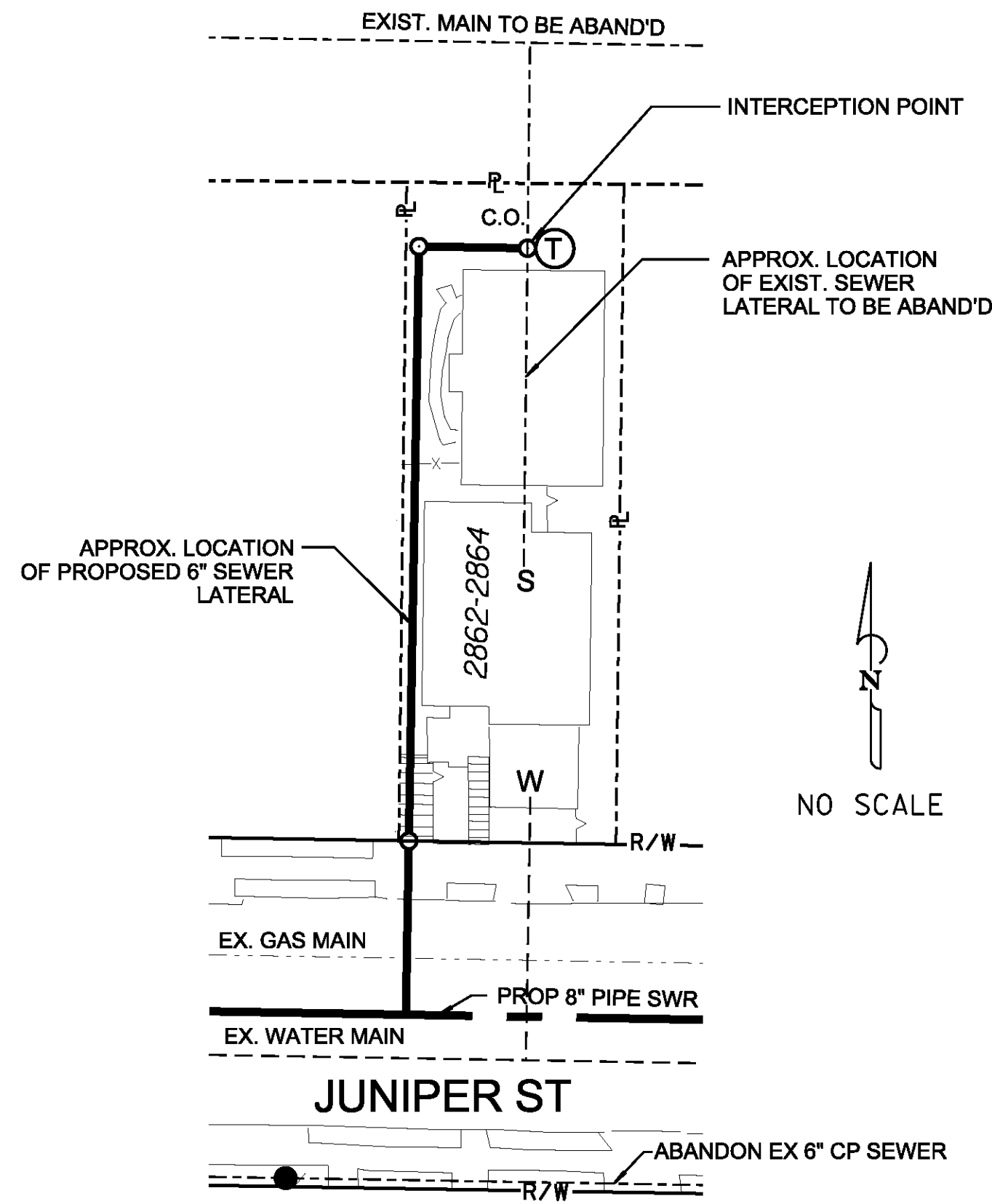

SEWER LATERAL REPLUMB WORK
ADDRESS: 2862-2864 JUNIPER ST
SEE SHEET 07

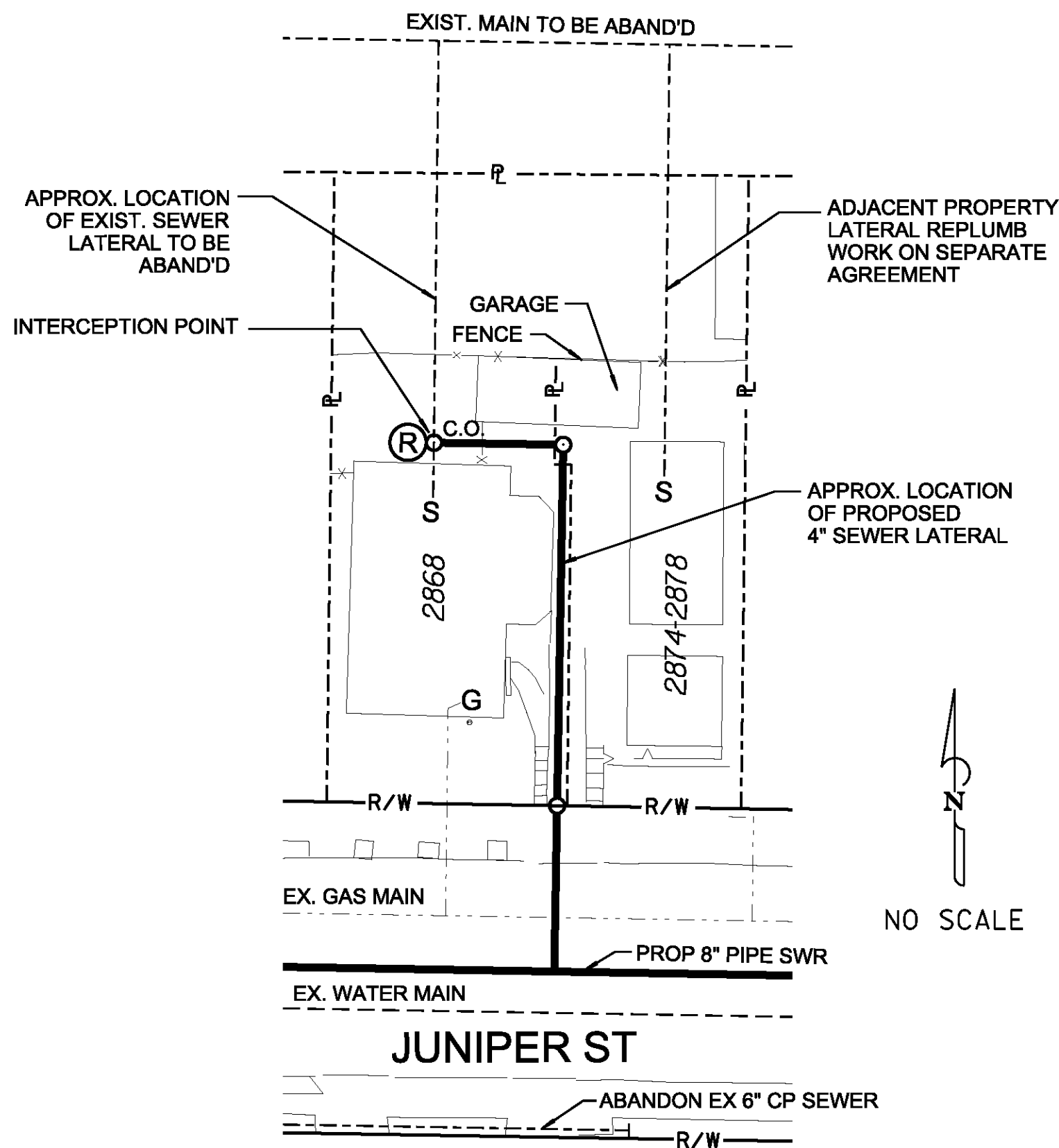

SEWER LATERAL REPLUMB WORK
ADDRESS: 2868 JUNIPER ST
SEE SHEET 07

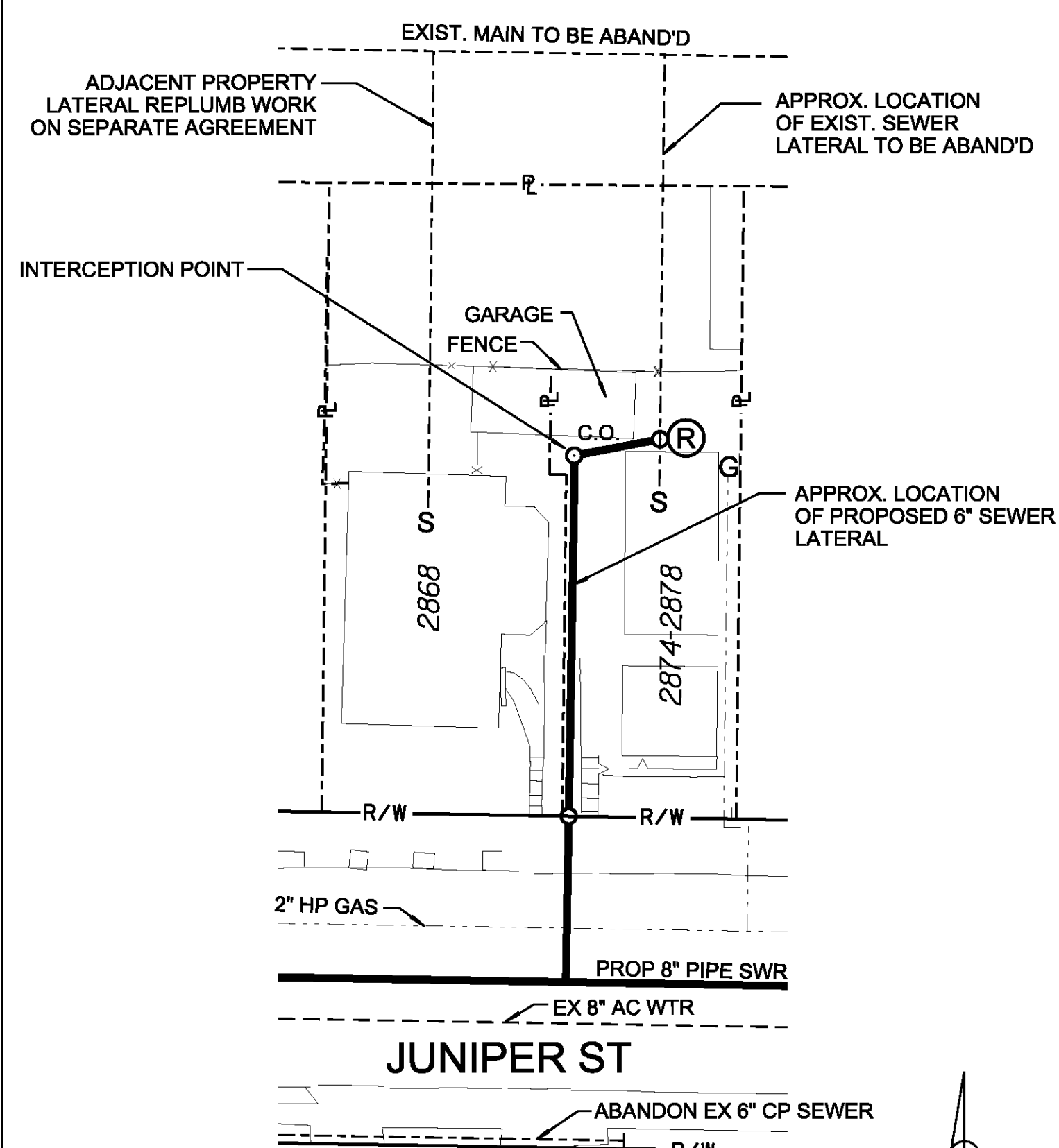

SEWER LATERAL REPLUMB WORK
ADDRESS: 2874-2878 JUNIPER ST
SEE SHEET 07

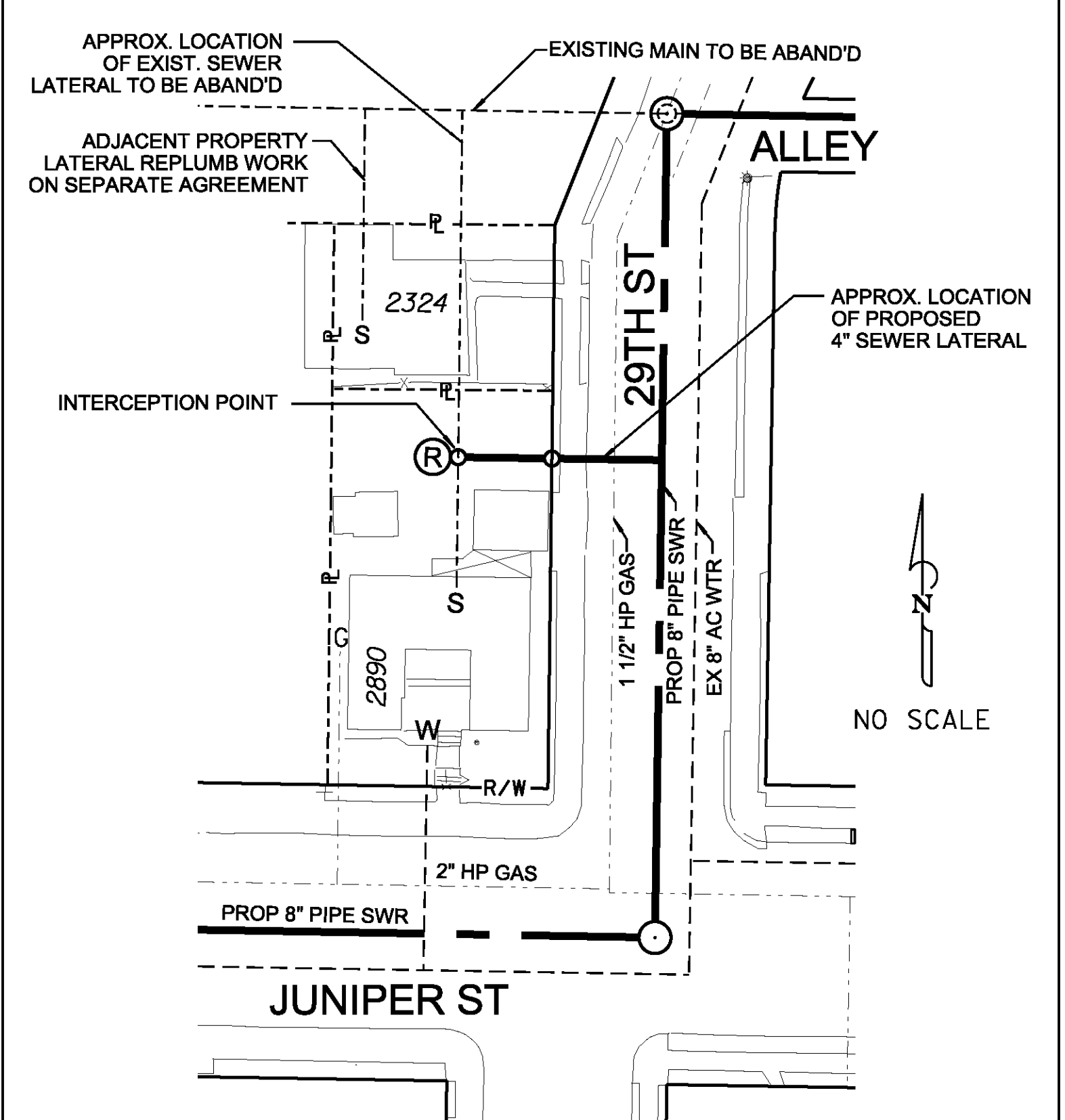

SEWER LATERAL REPLUMB WORK
ADDRESS: 2890 JUNIPER ST
SEE SHEET 08

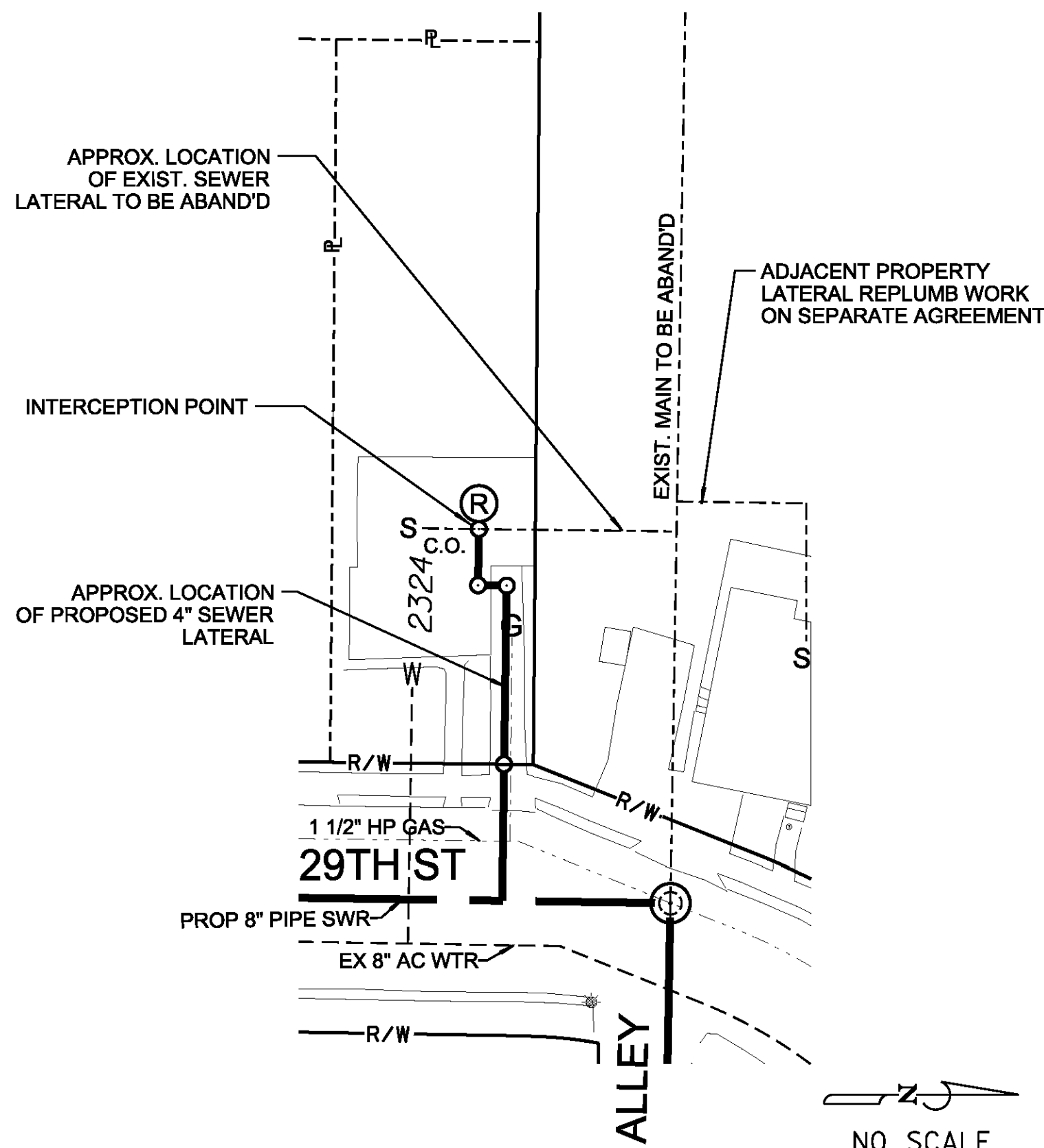

SEWER LATERAL REPLUMB WORK
ADDRESS: 2324 29TH ST
SEE SHEET 08

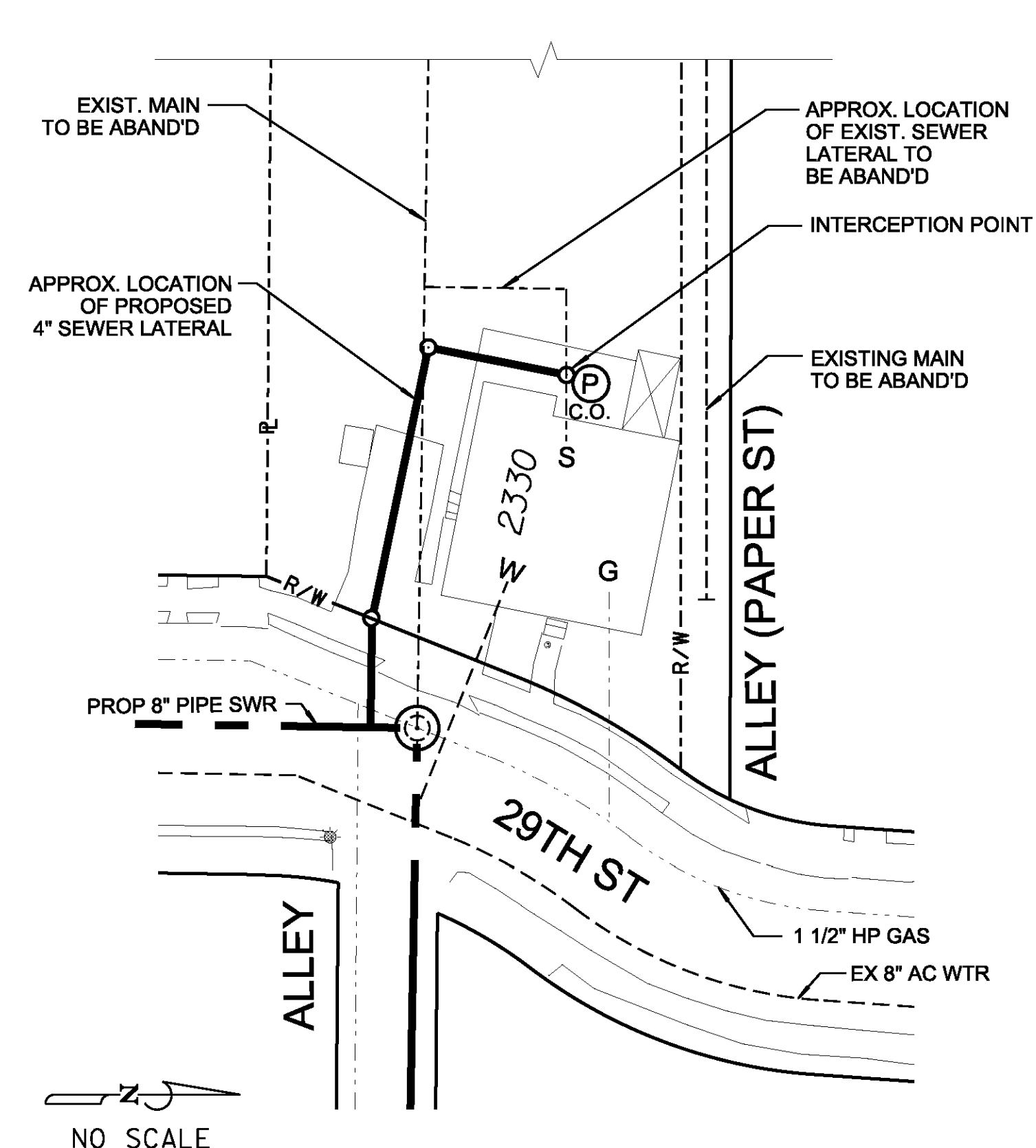

SEWER LATERAL REPLUMB WORK
ADDRESS: 2330 29TH ST
SEE SHEET 08

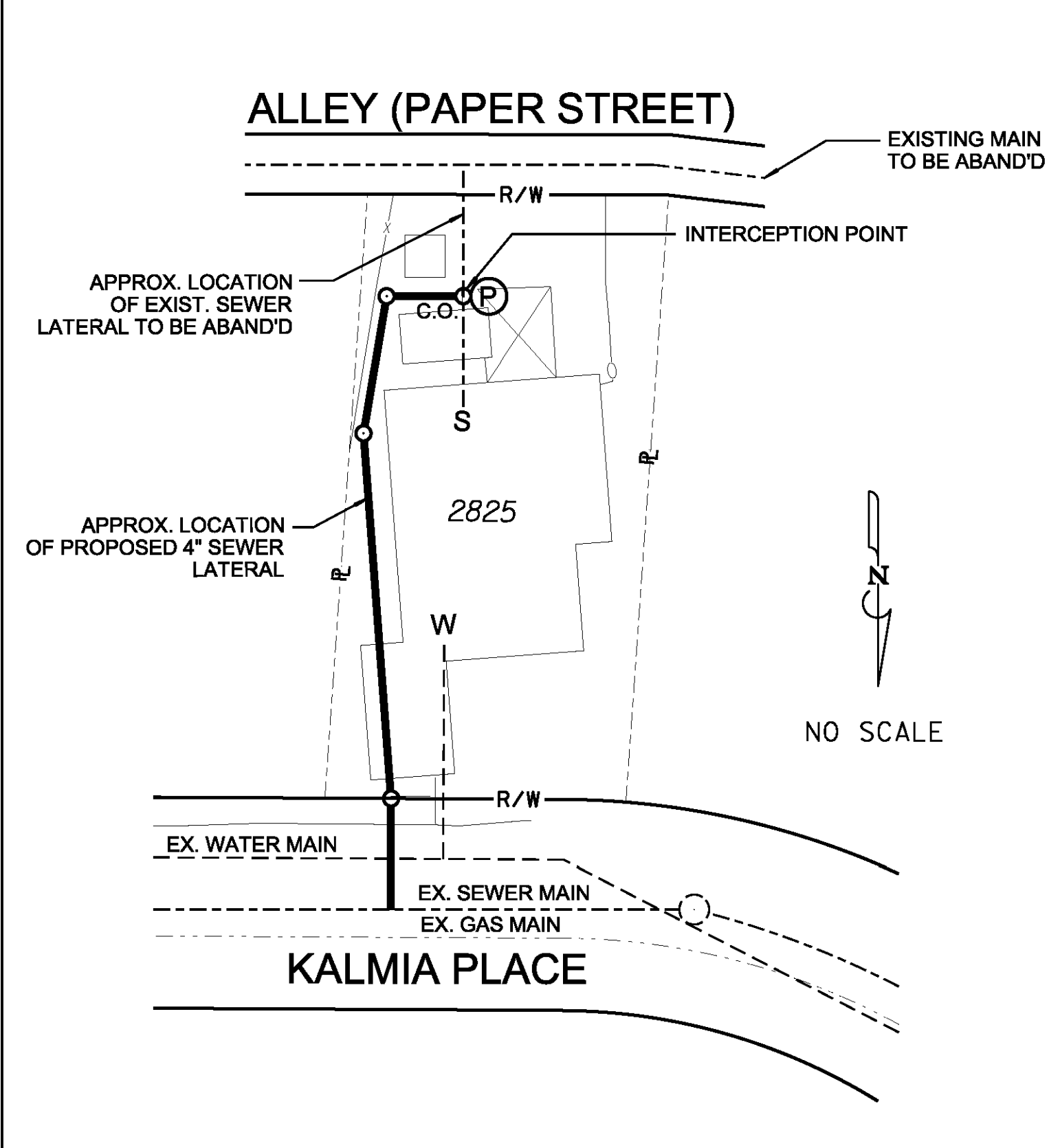

SEWER LATERAL REPLUMB WORK
ADDRESS: 2825 KALMIA PL
SEE SHEET 09

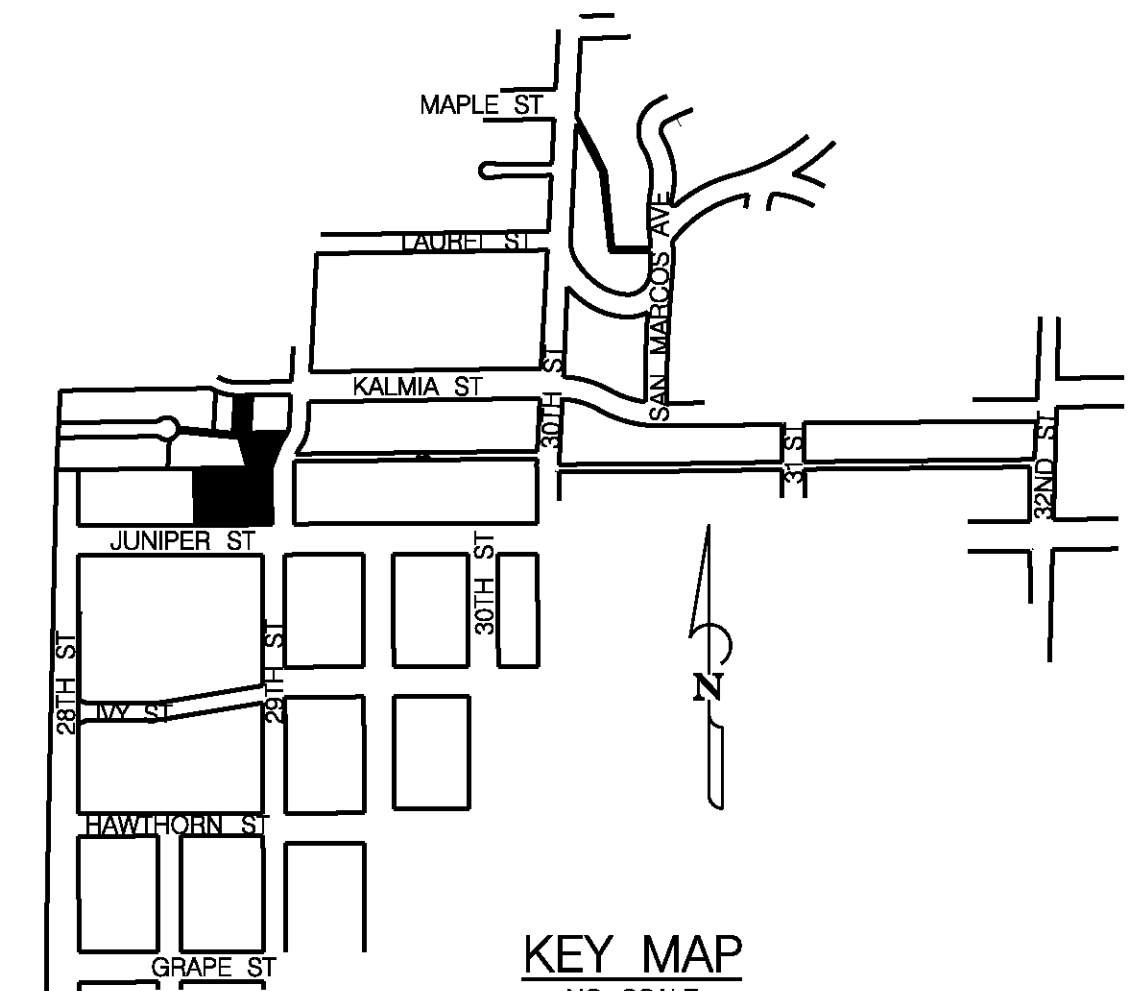

KEY MAP
NO SCALE

C-14

SEWER GROUP 691
REPLUMB DETAILS

CITY OF SAN DIEGO, CALIFORNIA PUBLIC WORKS DEPARTMENT SHEET 15 OF 21 SHEETS		WATER WBS - SEWER WBS B-00446
APPROVED BY: <i>Rania Amen</i> FOR CITY ENGINEER RANIA AMEN DCE NAME	DATE 7/14/2014	PROJECT MANAGER JERICHO GALLARDO
DESIGNED BY: JOSELITO QUINTO PROJECT ENGINEER	DESCRIPTION	NO. C 63507 09-30-2014 CIVIL
BY: JG/JG	APPROVED: [Signature]	DATE: [Blank]
FILED: [Blank]	DATE STARTED: [Blank]	DATE COMPLETED: [Blank]
CONTRACTOR: [Blank]	INSPECTOR: [Blank]	32506-15-D



REPLUMB DETAILS

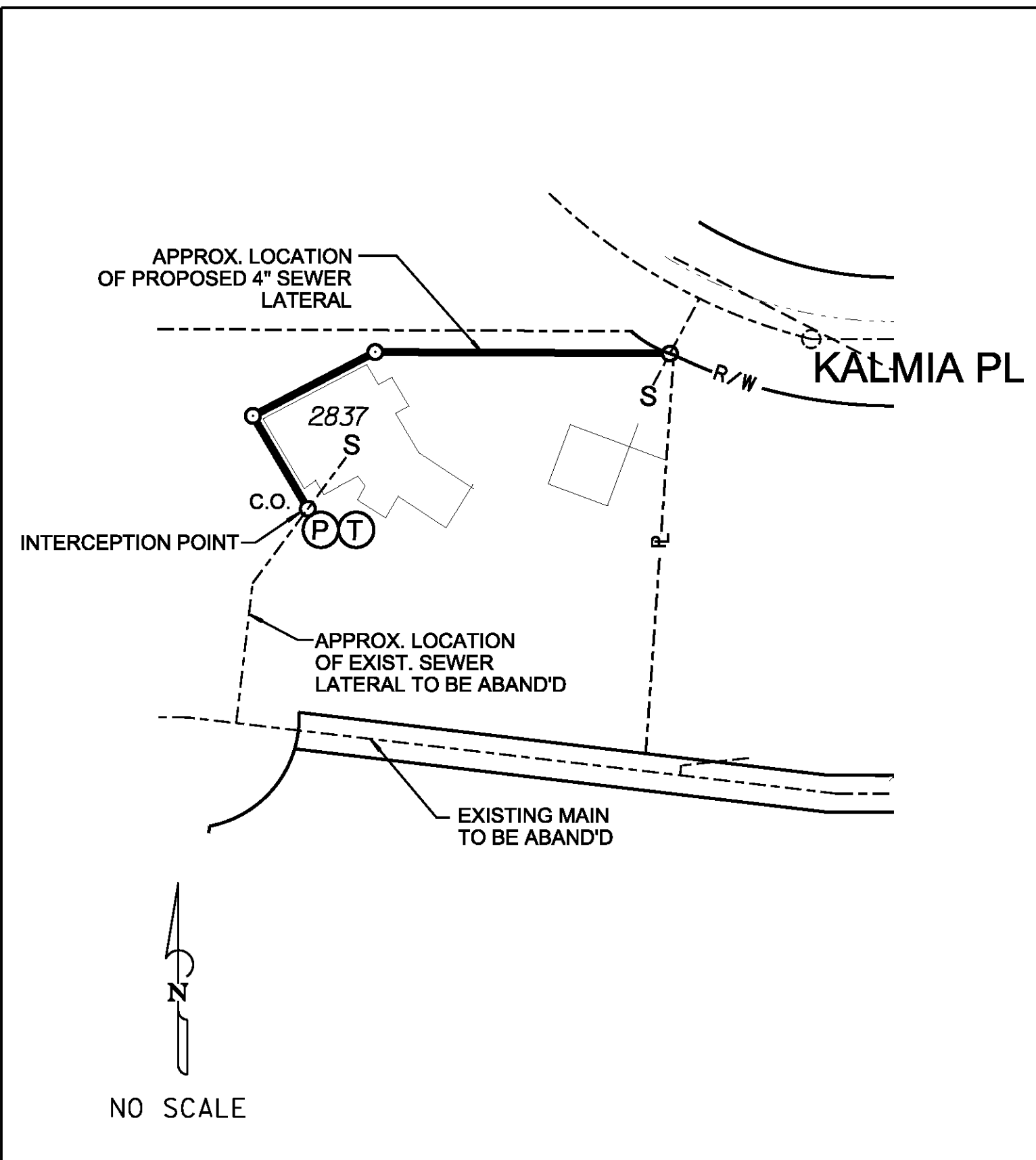

SEWER LATERAL REPLUMB WORK
ADDRESS: 2837 KALMIA PLACE
SEE SHEET 09

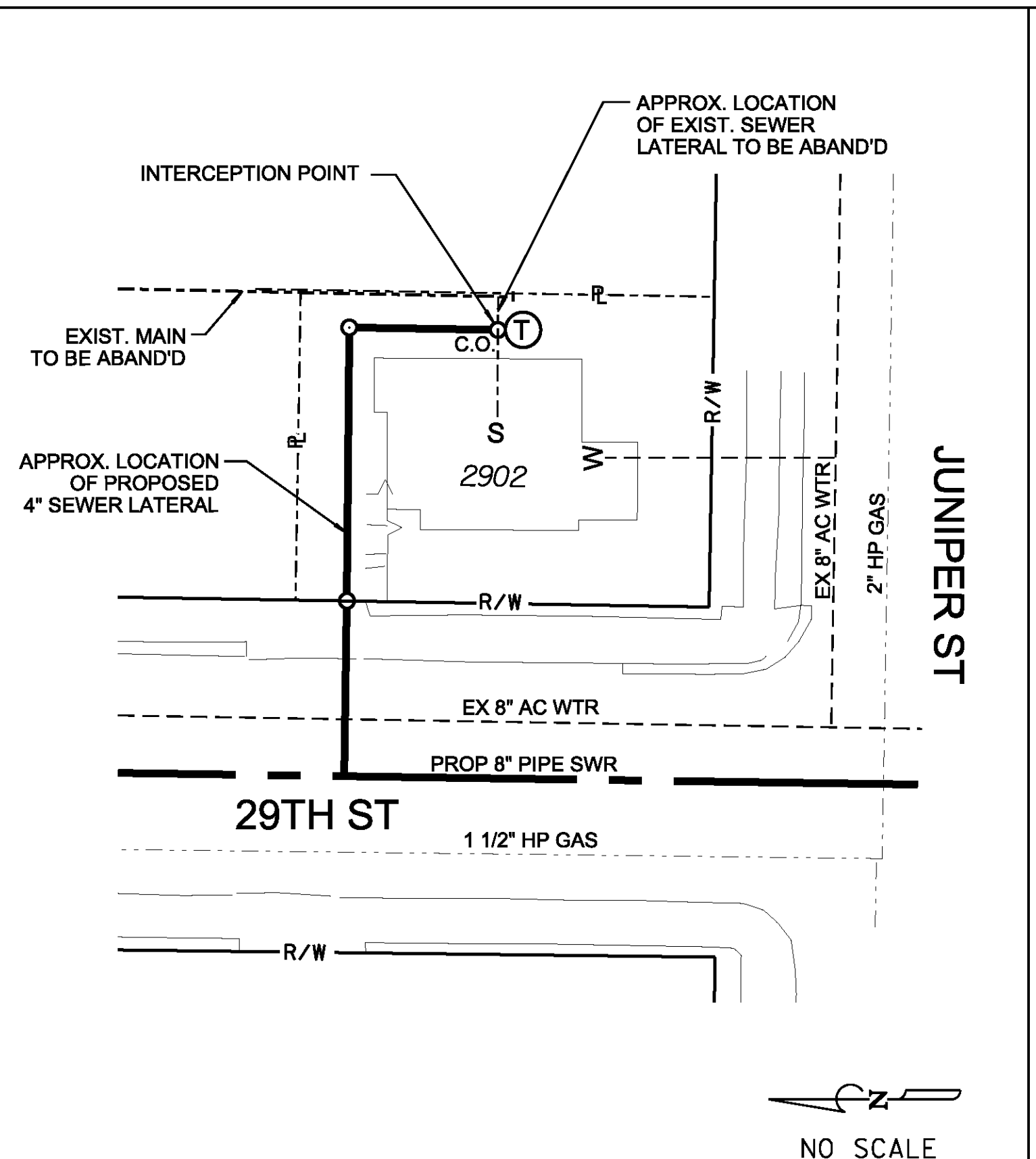

SEWER LATERAL REPLUMB WORK
ADDRESS: 2902 JUNIPER ST
SEE SHEET 08

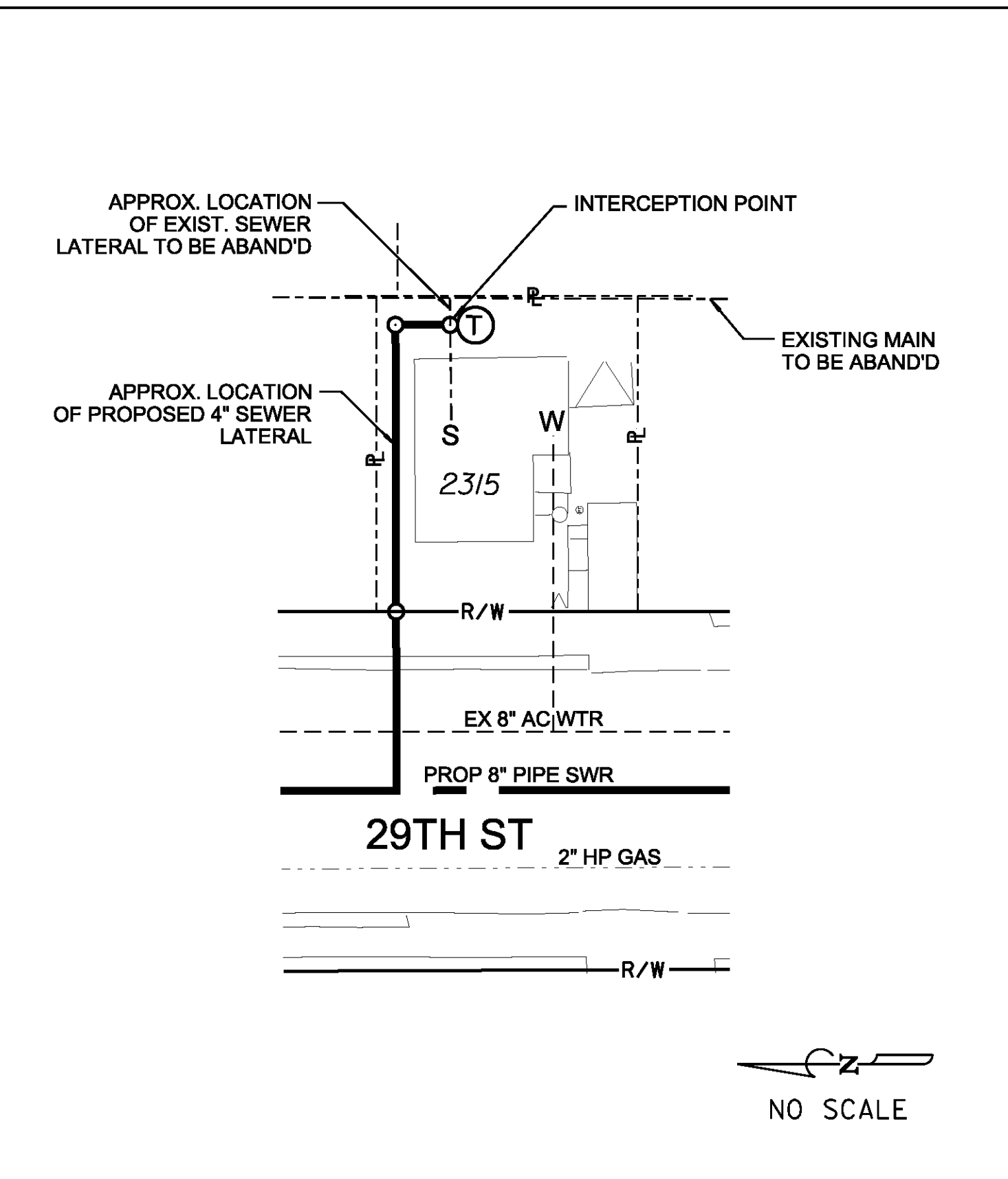

SEWER LATERAL REPLUMB WORK
ADDRESS: 2315 29TH ST
SEE SHEET 08

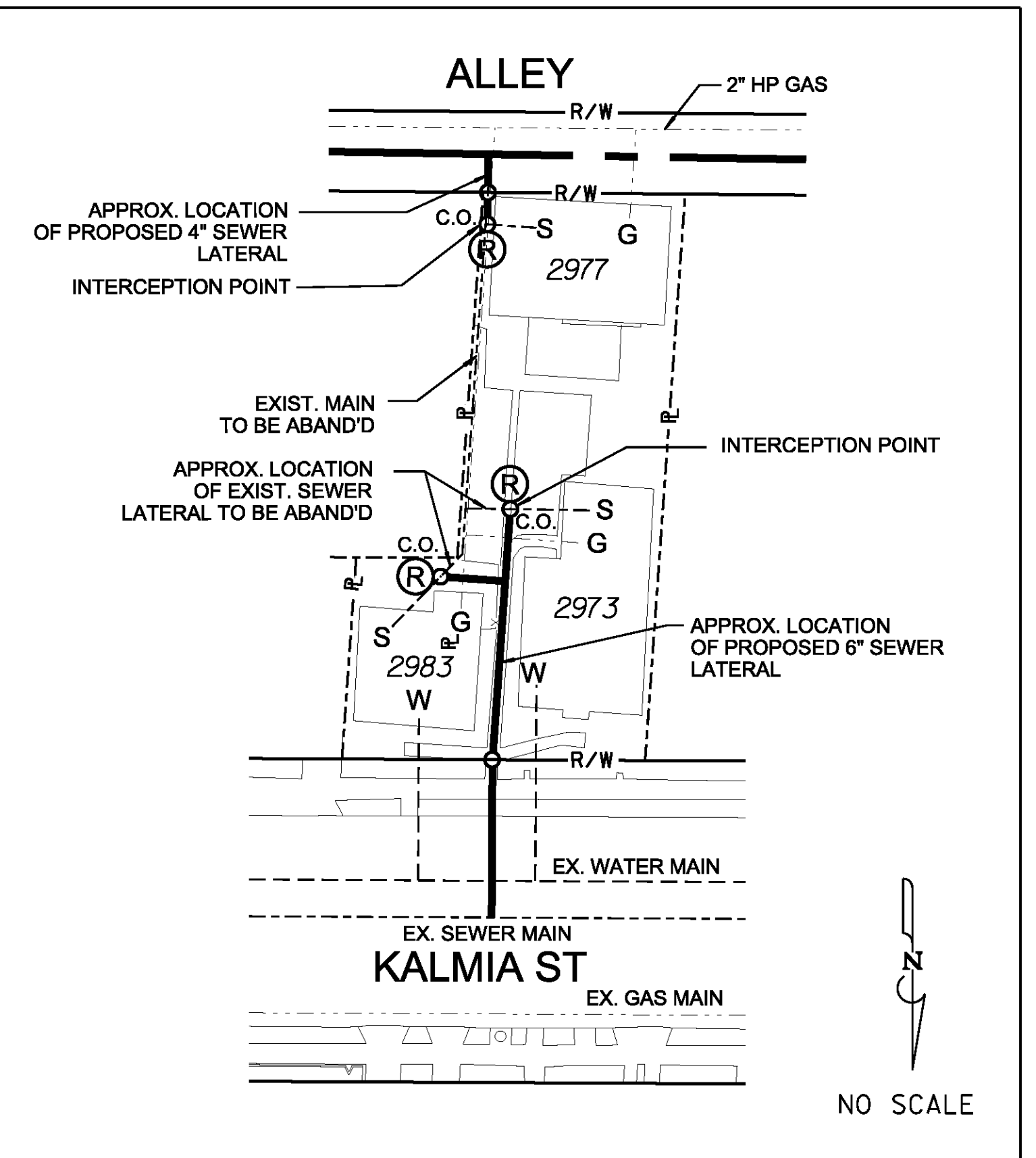

SEWER LATERAL REPLUMB WORK
ADDRESS: 2973-2983 KALMIA ST
SEE SHEET 08 & 09

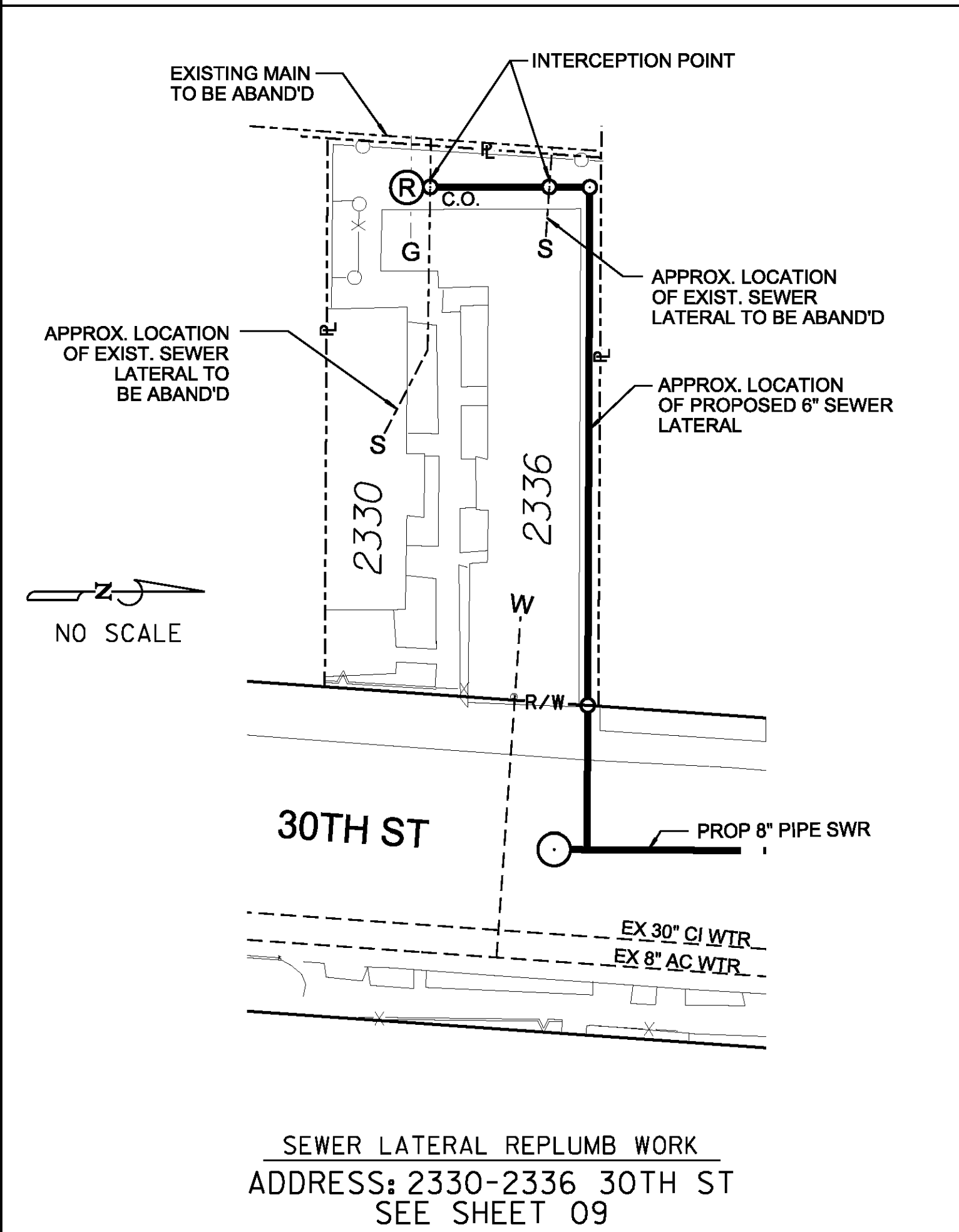

SEWER LATERAL REPLUMB WORK
ADDRESS: 2330-2336 30TH ST
SEE SHEET 09

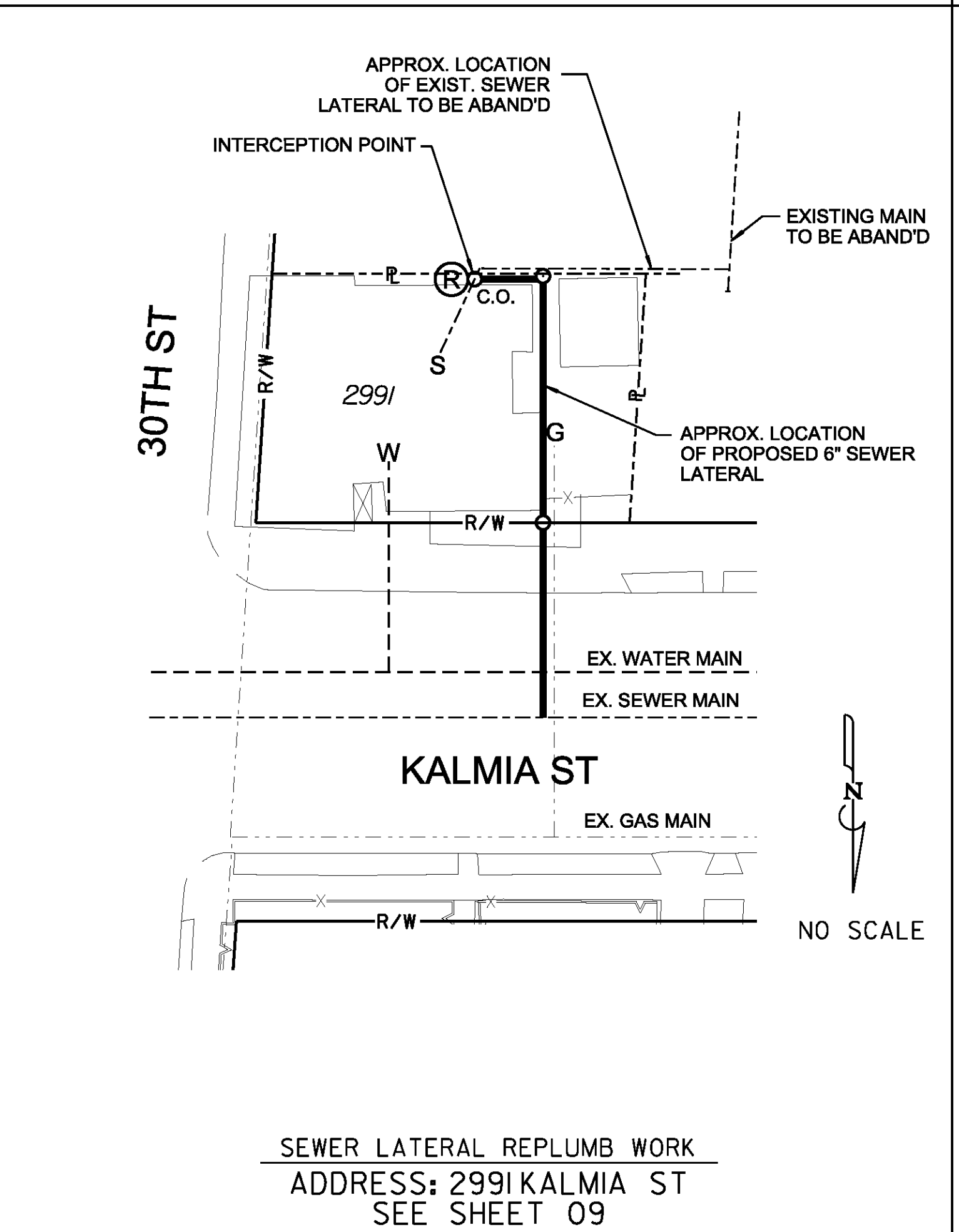

SEWER LATERAL REPLUMB WORK
ADDRESS: 2991 KALMIA ST
SEE SHEET 09

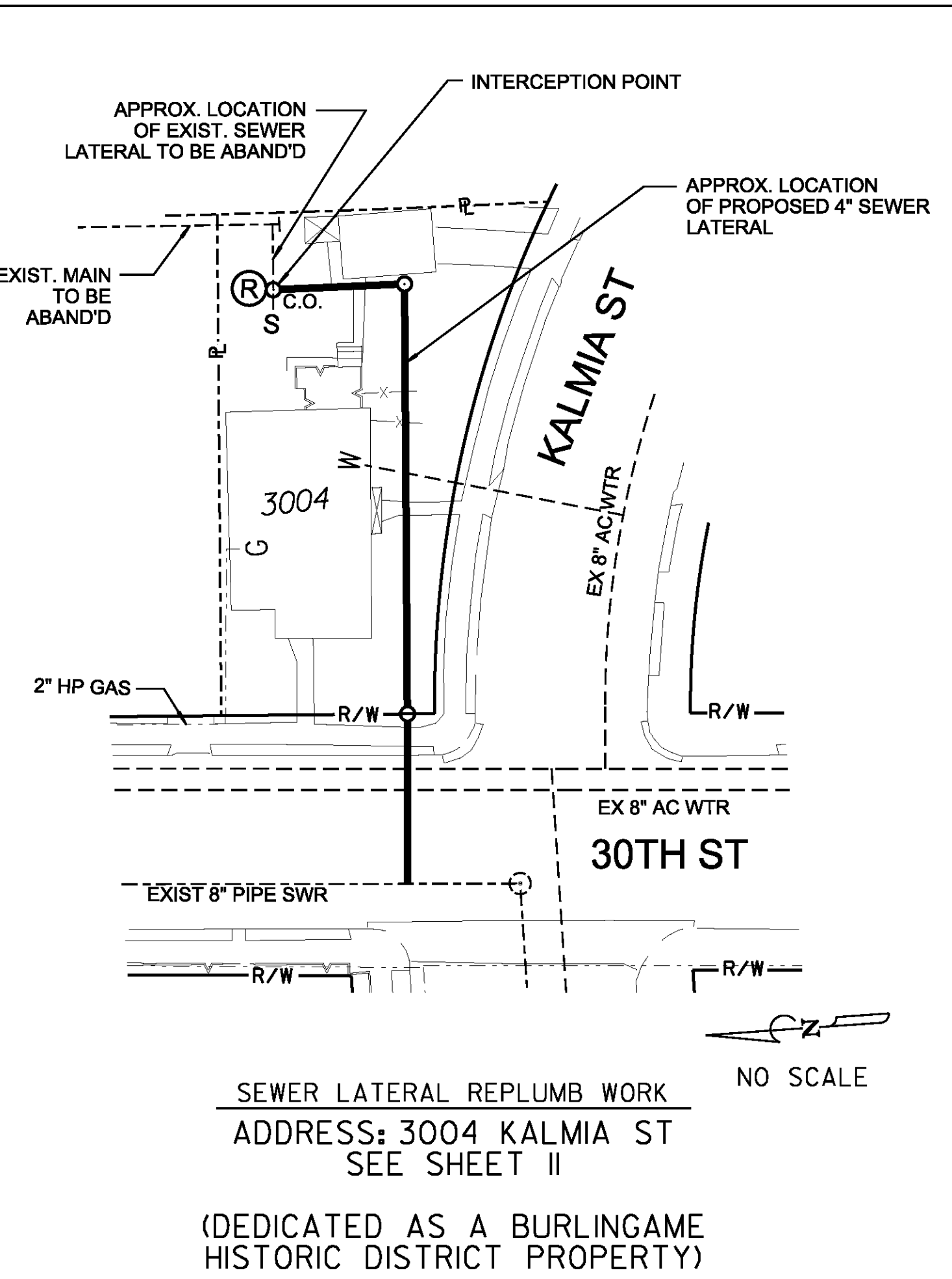

SEWER LATERAL REPLUMB WORK
ADDRESS: 3004 KALMIA ST
SEE SHEET II
(DEDICATED AS A BURLINGAME
HISTORIC DISTRICT PROPERTY)

KEY MAP
NO SCALE

C-15

SEWER GROUP 691 REPLUMB DETAILS			
CITY OF SAN DIEGO, CALIFORNIA PUBLIC WORKS DEPARTMENT SHEET 16 OF 21 SHEETS			WATER WBS - SEWER WBS B-00446
APPROVED BY: FOR CITY ENGINEER RANIA AMEN DCE NAME		DATE: 7/14/2014	
DESIGNED BY: PROJECT ENGINEER		PROJECT MANAGER	
SEE EACH SHEET CCS27 COORDINATE			
SEE EACH SHEET CCS83 COORDINATE			
CONTRACTOR: _____		DATE STARTED: _____	
INSPECTOR: _____		DATE COMPLETED: _____	
32506-16-D			

REPLUMB DETAILS

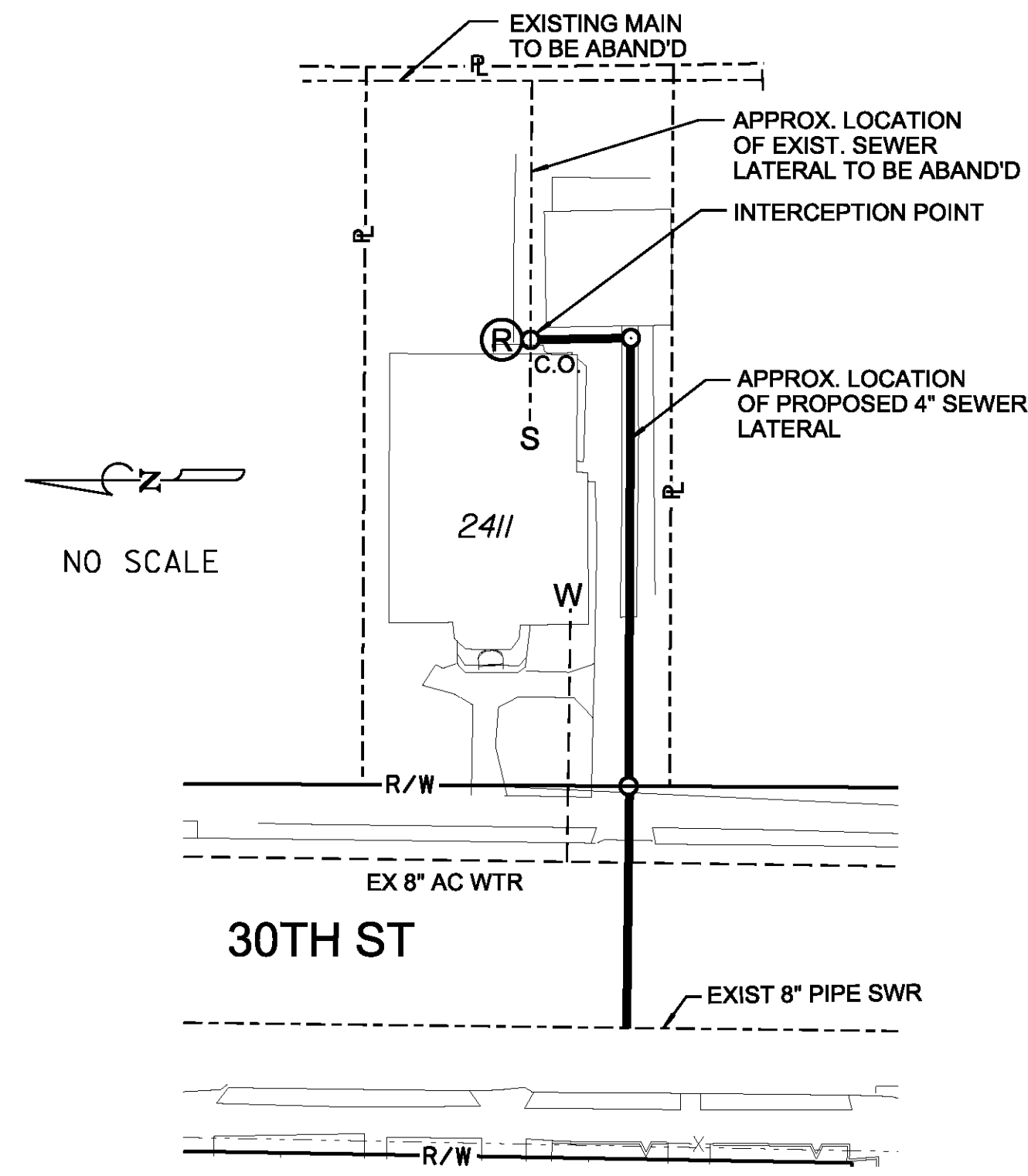

SEWER LATERAL REPLUMB WORK
ADDRESS: 2411 30TH ST
SEE SHEET II

(DEDICATED AS A BURLINGAME
HISTORIC DISTRICT PROPERTY)

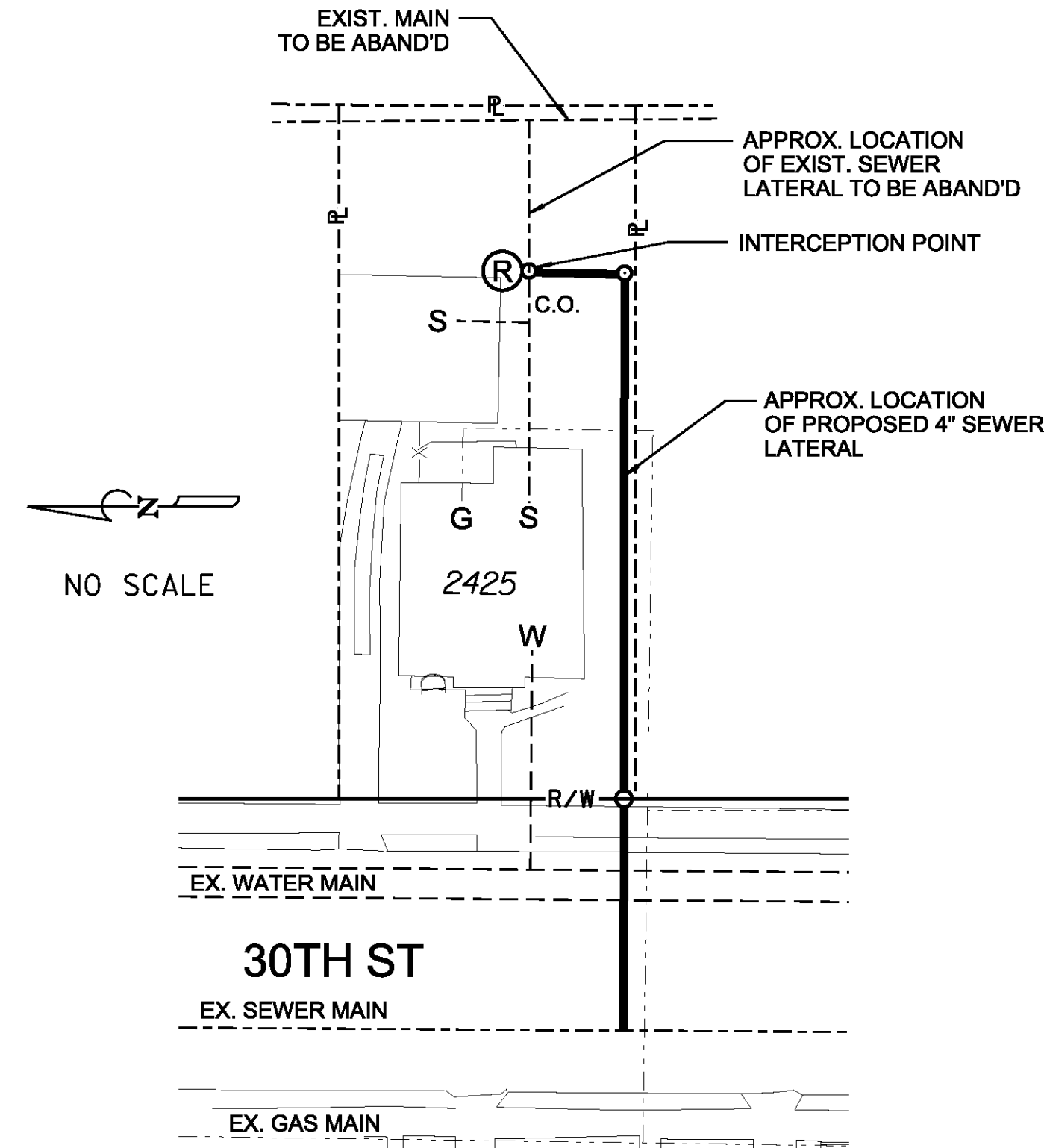

SEWER LATERAL REPLUMB WORK
ADDRESS: 2425 30TH ST
SEE SHEET II

(DEDICATED AS A BURLINGAME
HISTORIC DISTRICT PROPERTY)

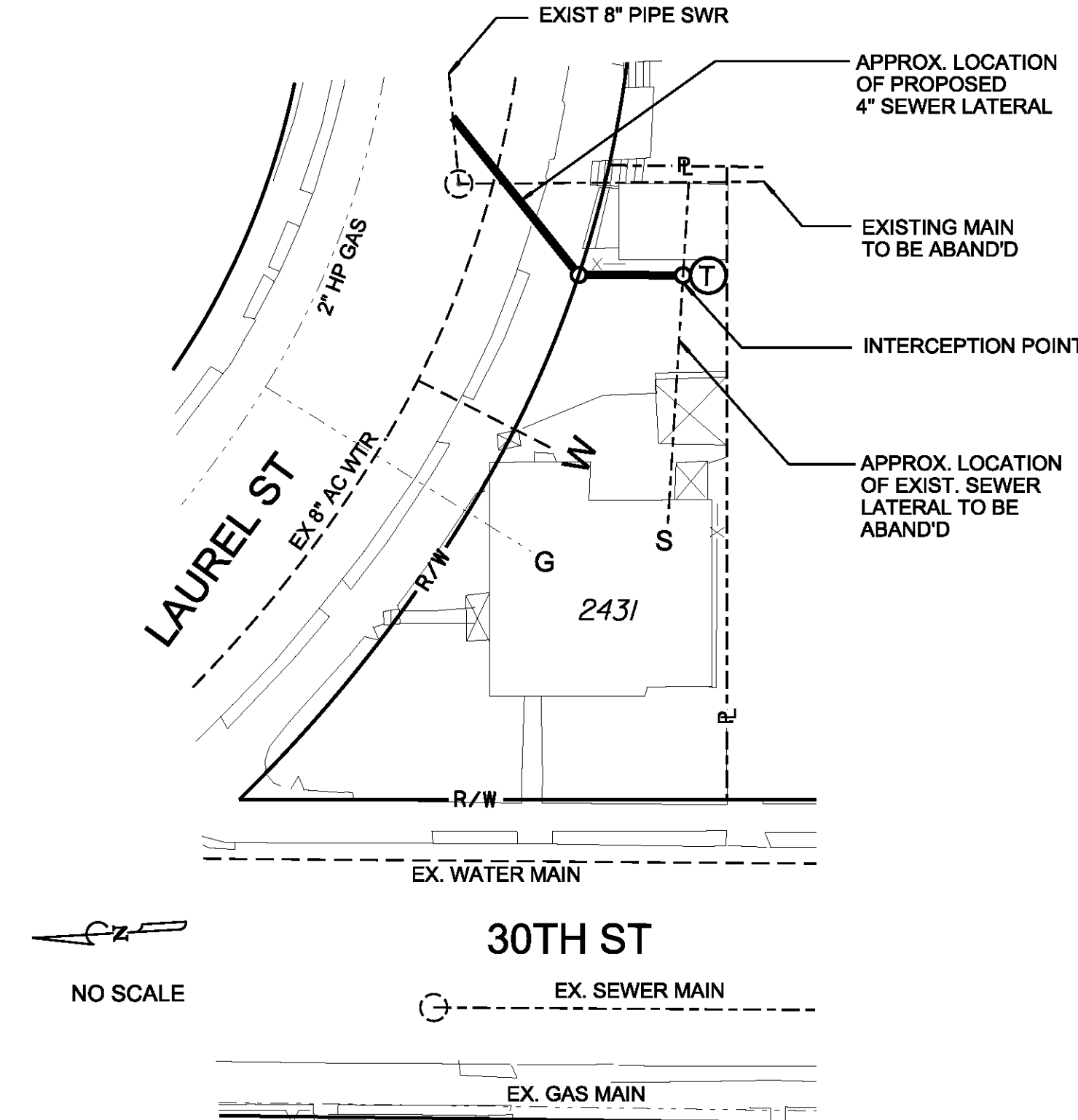

SEWER LATERAL REPLUMB WORK
ADDRESS: 2431 30TH ST
SEE SHEET II

(DEDICATED AS A BURLINGAME
HISTORIC DISTRICT PROPERTY)

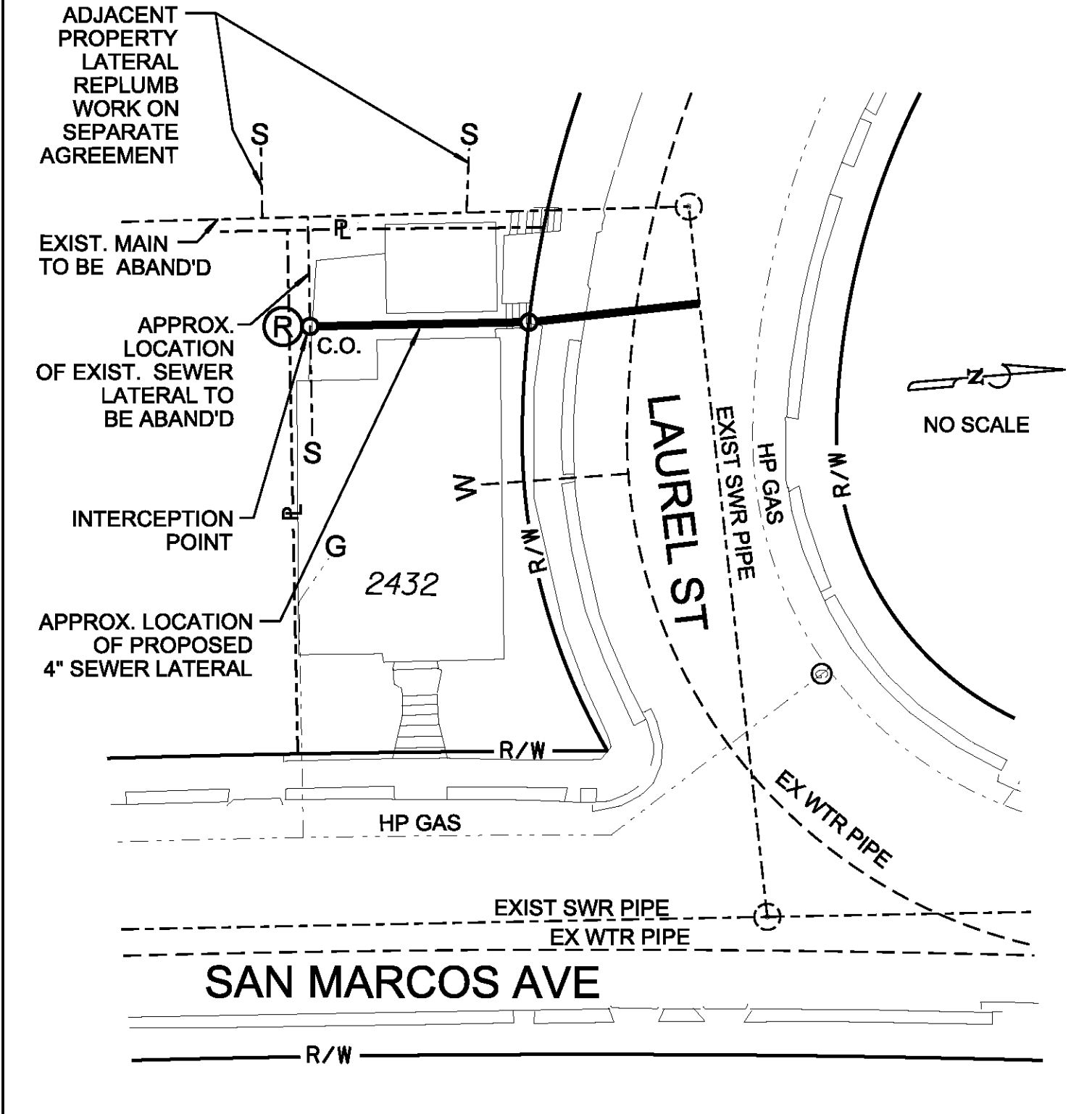

SEWER LATERAL REPLUMB WORK
ADDRESS: 2432 SAN MARCOS AVE
SEE SHEET II

(DEDICATED AS A BURLINGAME
HISTORIC DISTRICT PROPERTY)

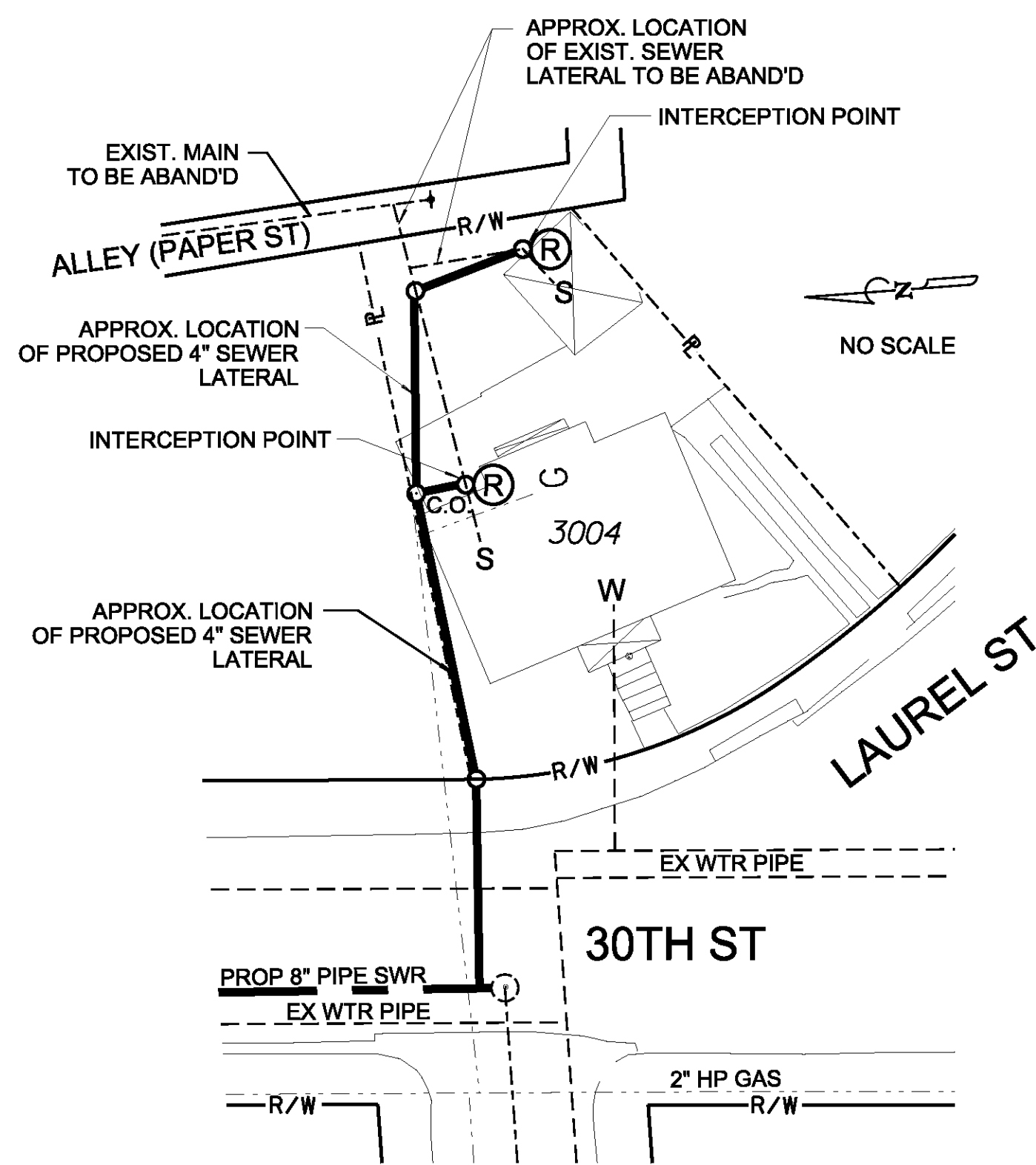

SEWER LATERAL REPLUMB WORK
ADDRESS: 3004 LAUREL ST
SEE SHEET II

(DEDICATED AS A BURLINGAME
HISTORIC DISTRICT PROPERTY)

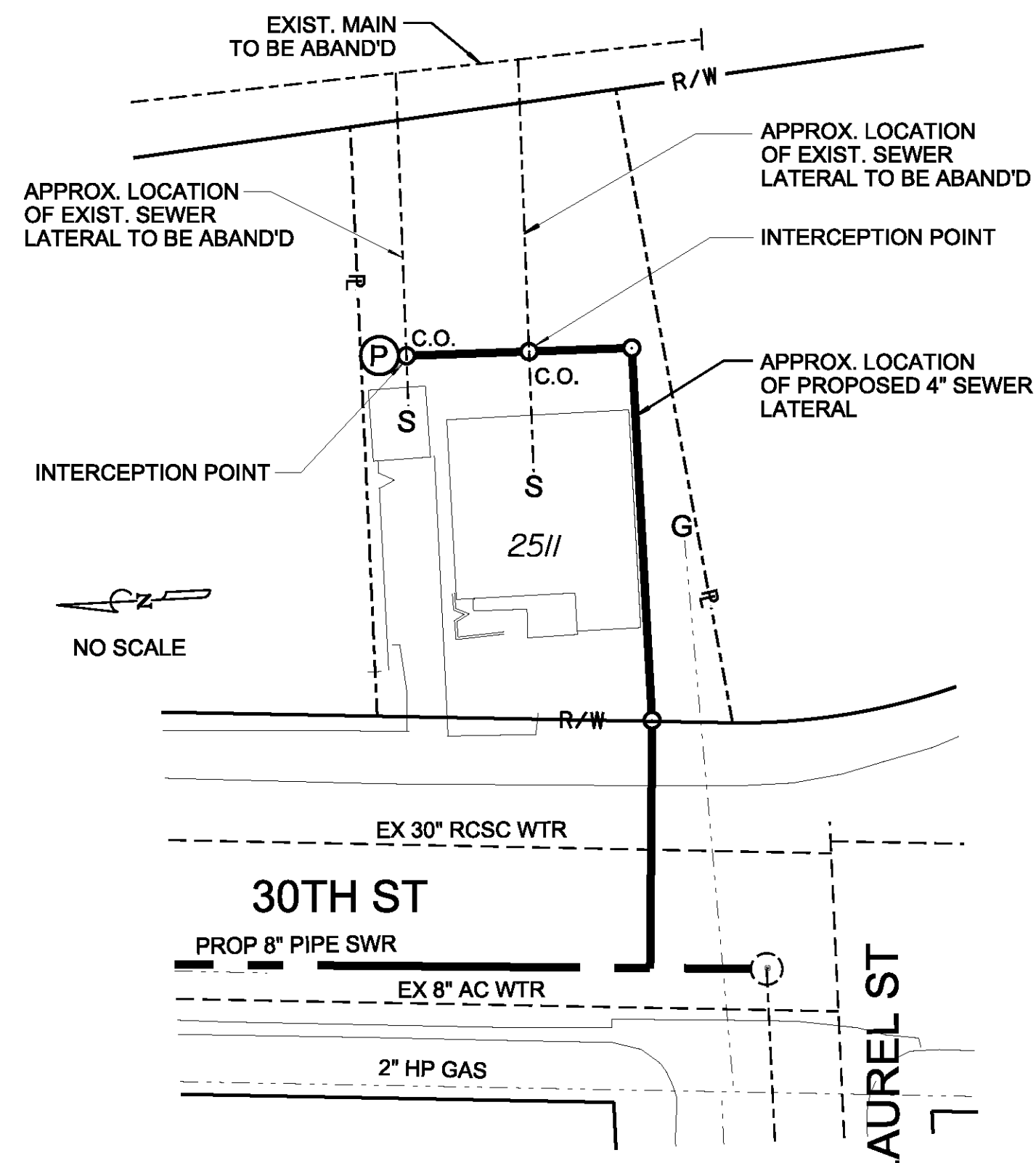

SEWER LATERAL REPLUMB WORK
ADDRESS: 2511 30TH ST
SEE SHEET II

(DEDICATED AS A BURLINGAME
HISTORIC DISTRICT PROPERTY)

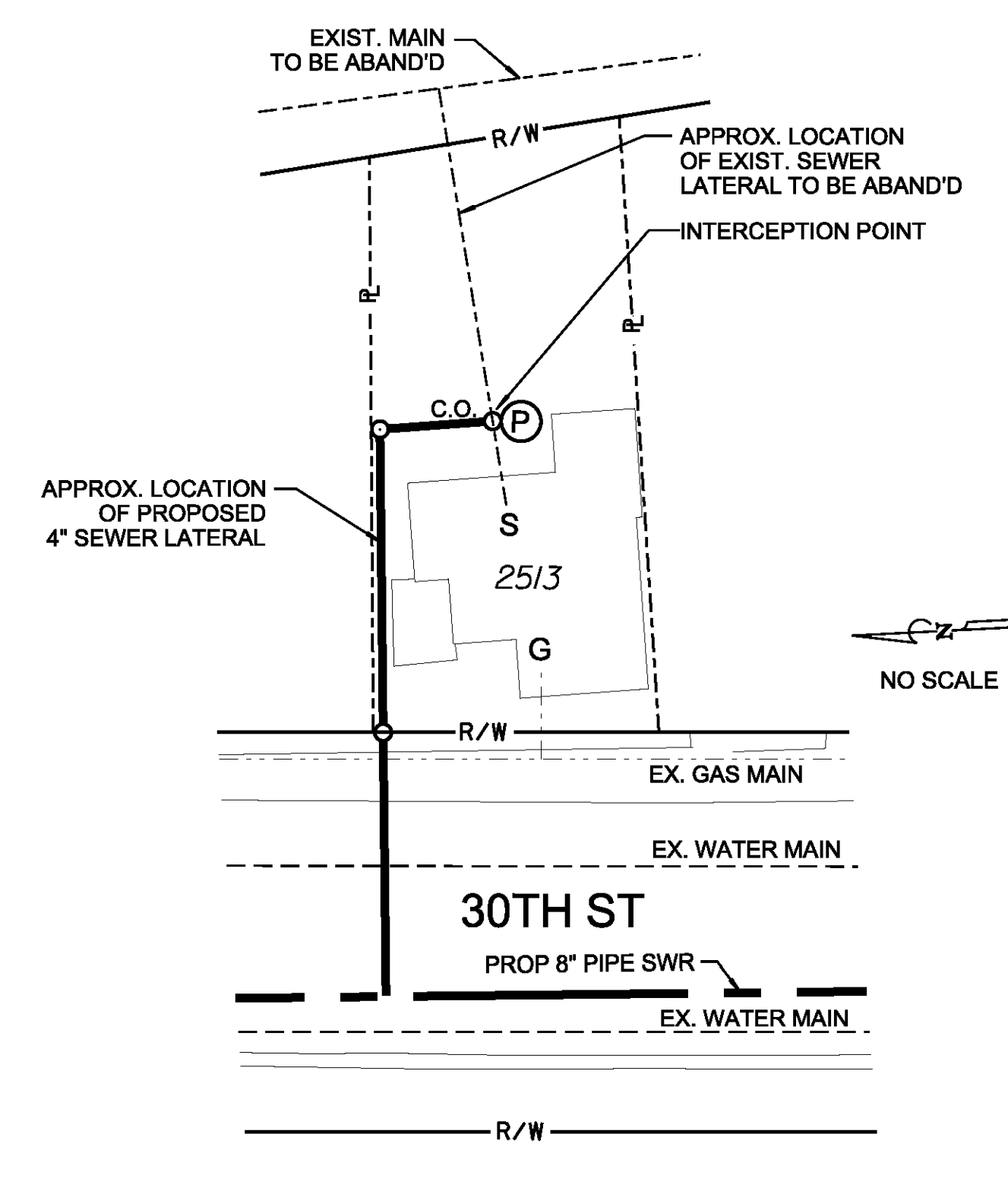

SEWER LATERAL REPLUMB WORK
ADDRESS: 2513 30TH ST
SEE SHEET II

(DEDICATED AS A BURLINGAME
HISTORIC DISTRICT PROPERTY)

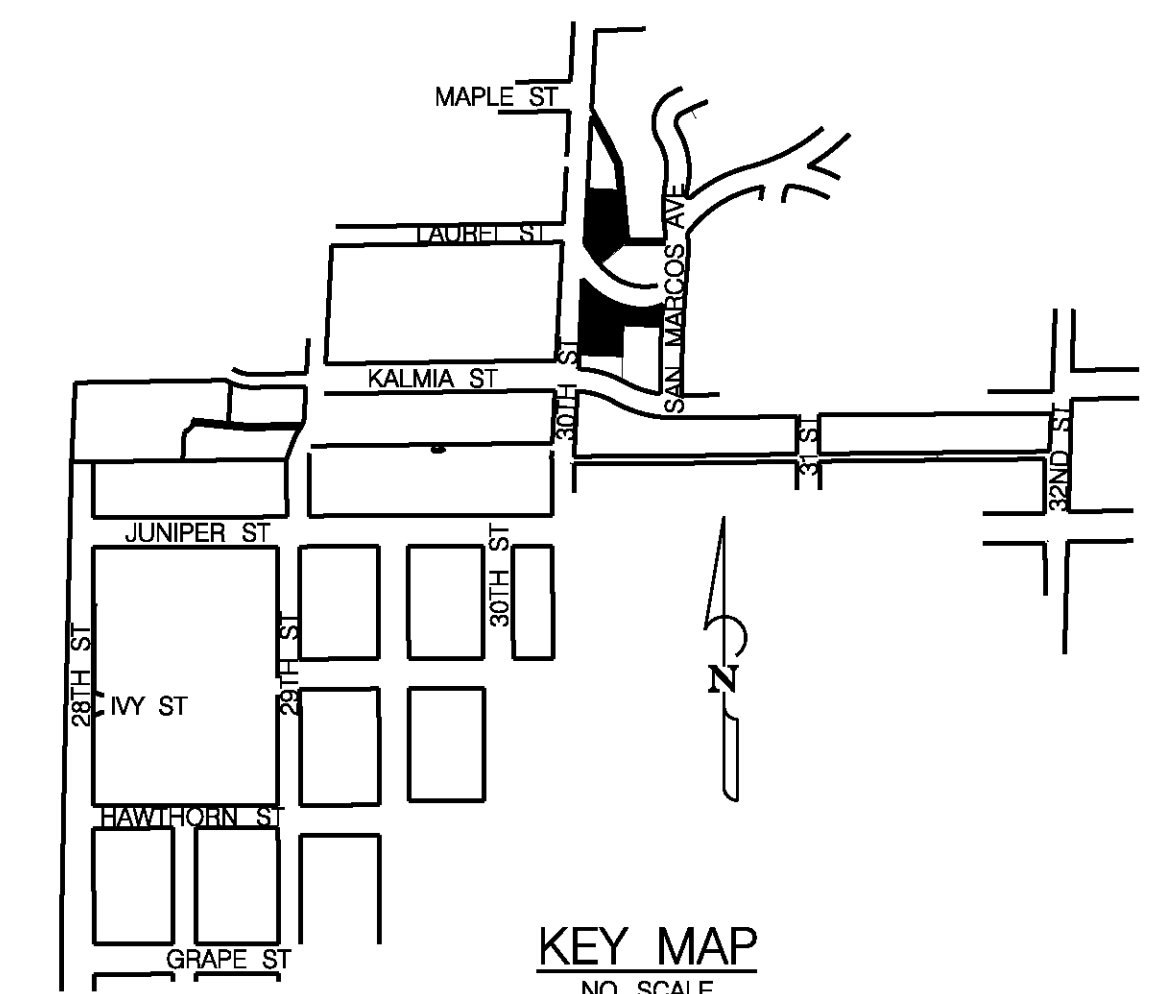

KEY MAP
NO SCALE

C-16

SEWER GROUP 691
REPLUMB DETAILS

CITY OF SAN DIEGO, CALIFORNIA PUBLIC WORKS DEPARTMENT SHEET 17 OF 21 SHEETS		WATER WBS SEWER WBS	B-00446
FOR CITY ENGINEER RANIA AMEN DATE 7/14/2014		PROJECT MANAGER JERICHO GALLARDO	
CHECKED BY JOSELITO QUINTO PROJECT ENGINEER		SEE EACH SHEET CC527 COORDINATE	
DESCRIPTION		BY	APPROVED
ORIGINAL	JG/JG		
CONTRACTOR		DATE STARTED	
INSPECTOR		DATE COMPLETED	
		32506-17-D	

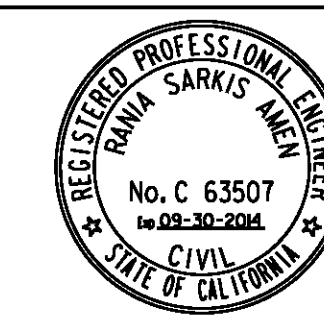

REPLUMB DETAILS

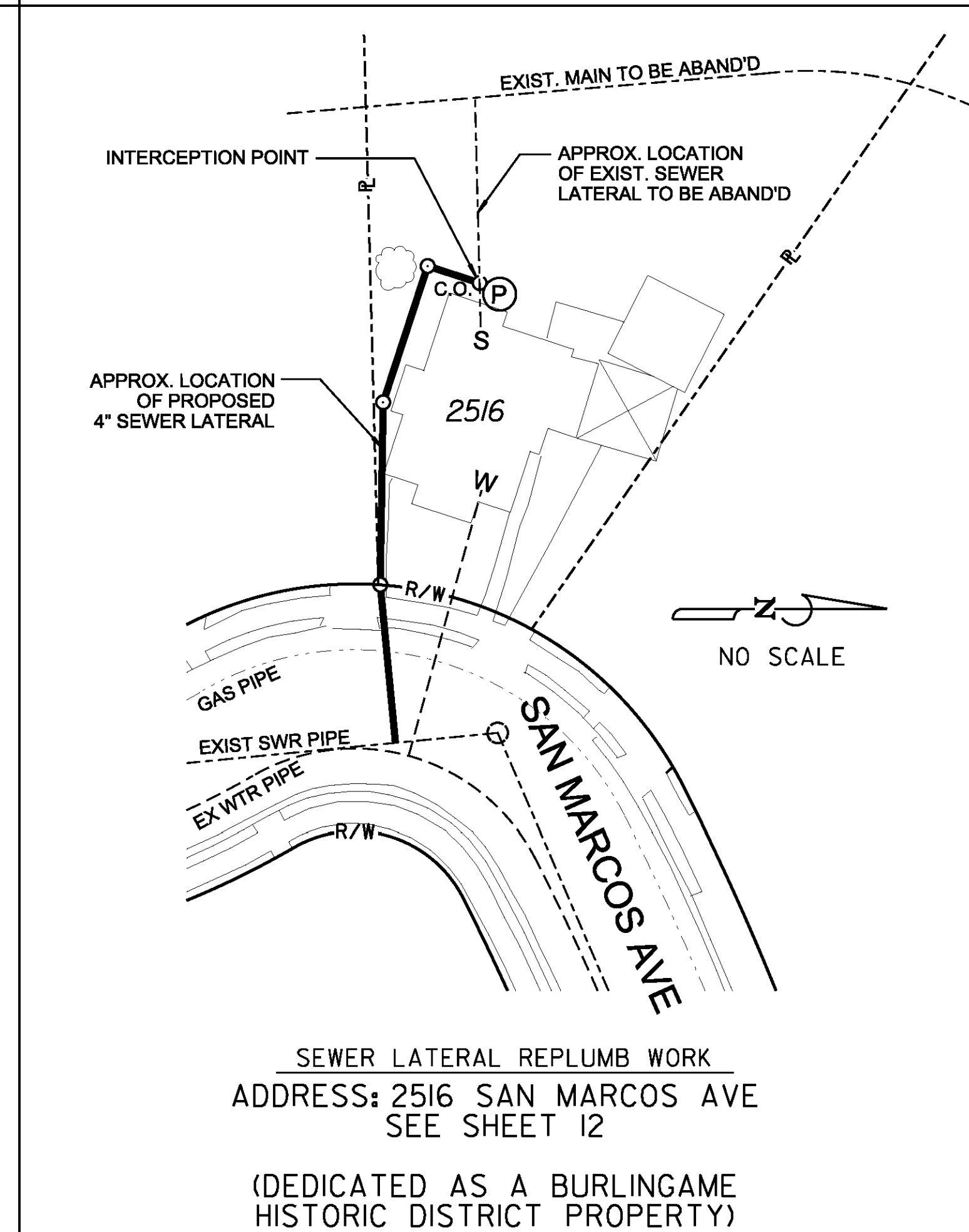
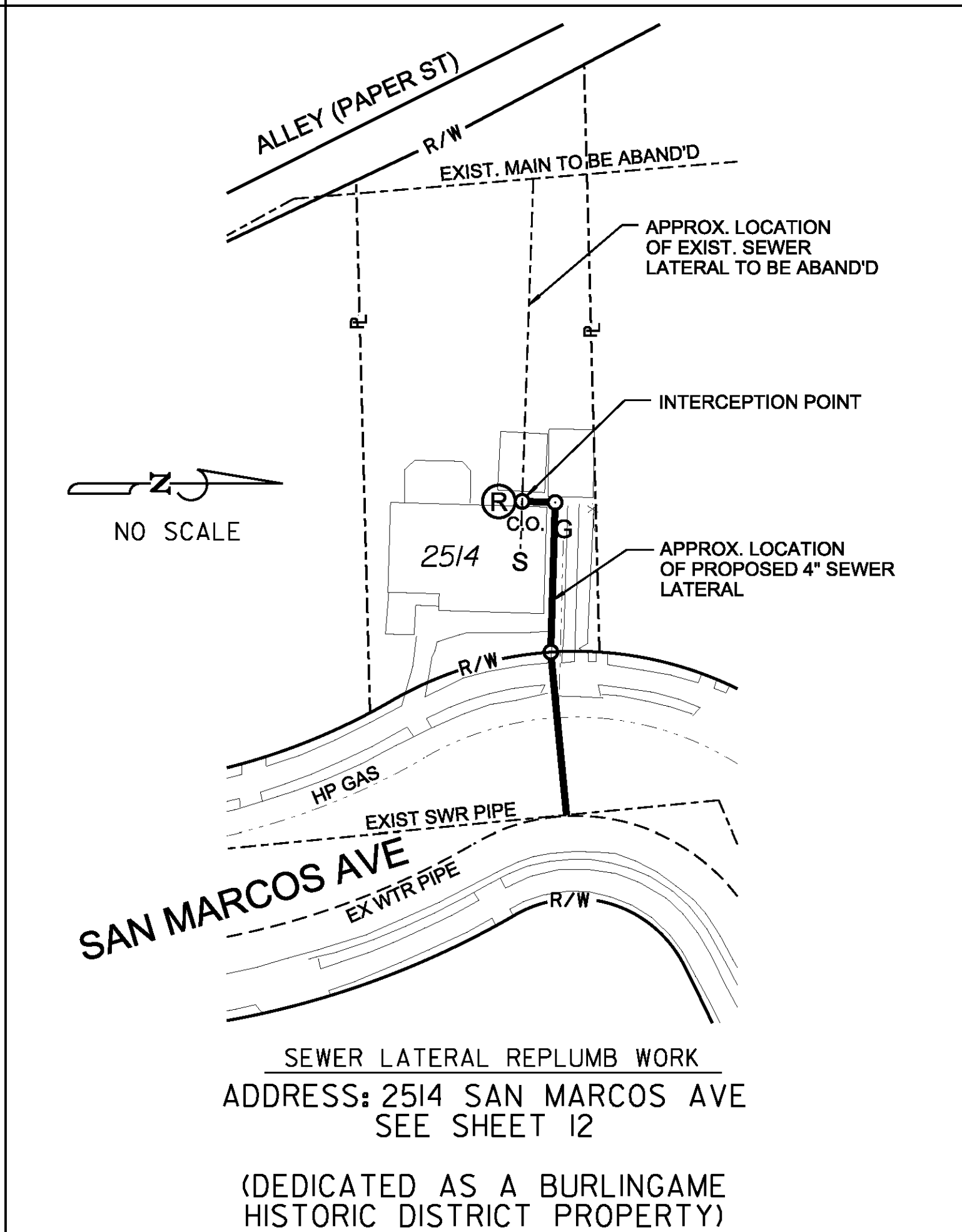
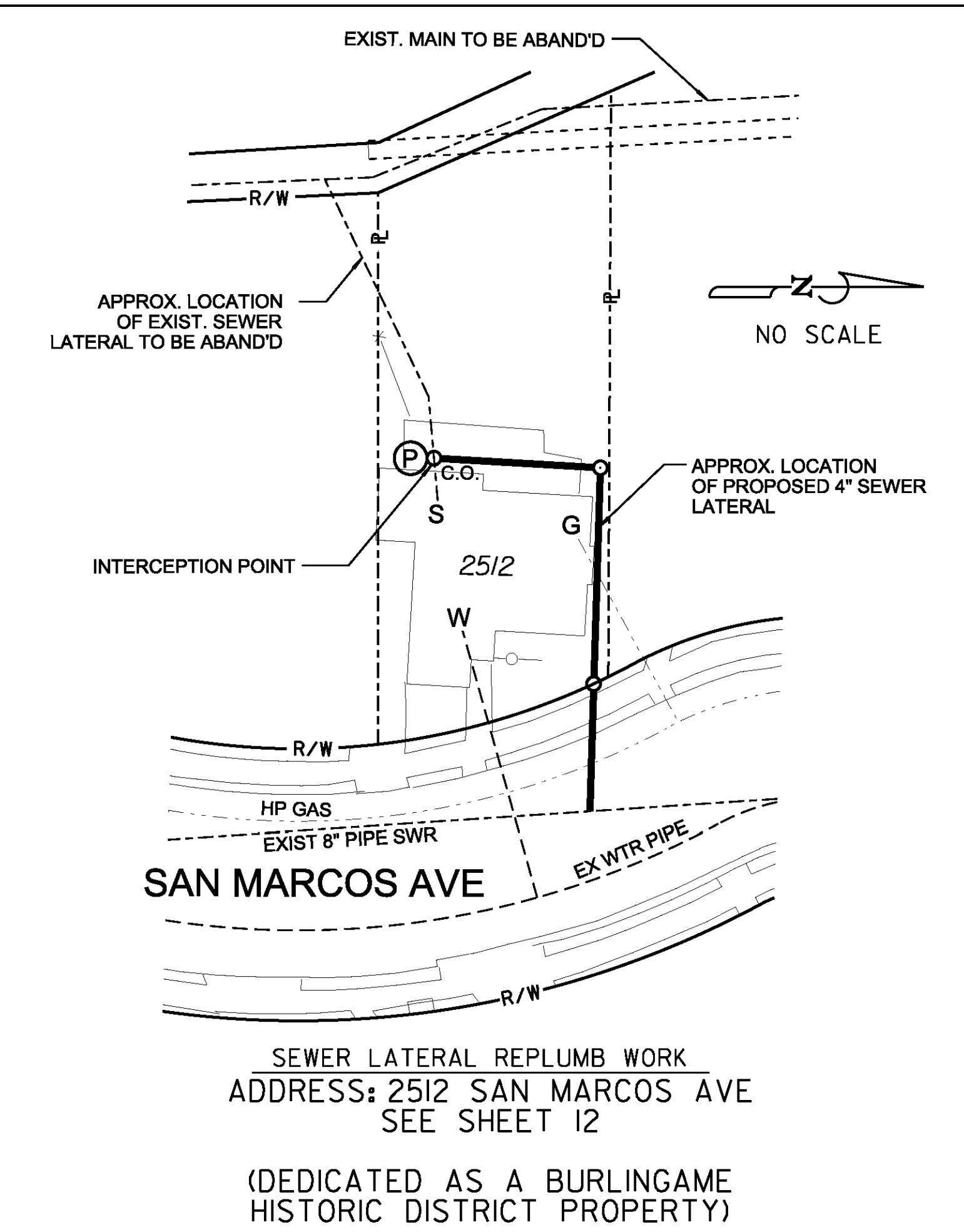
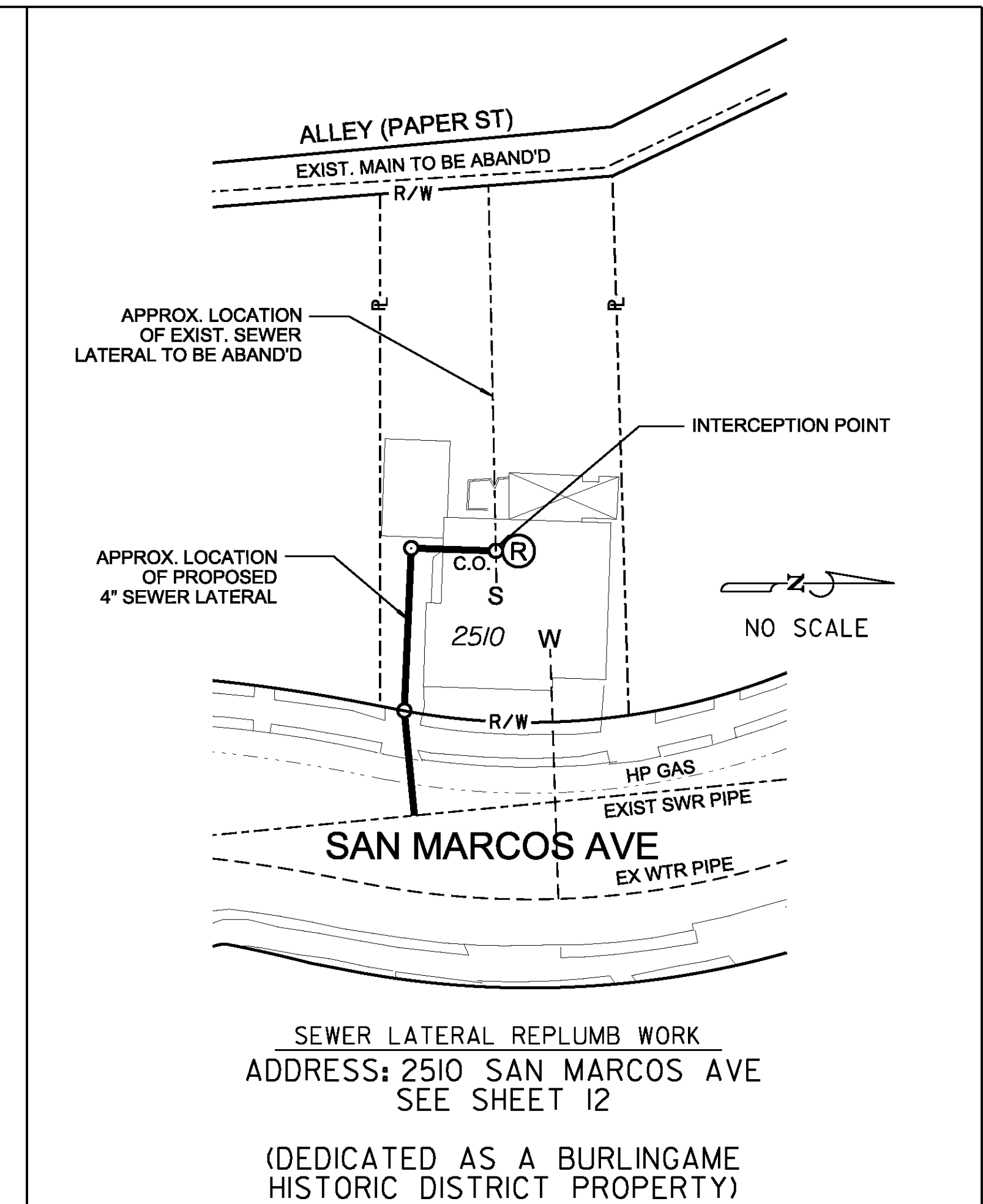
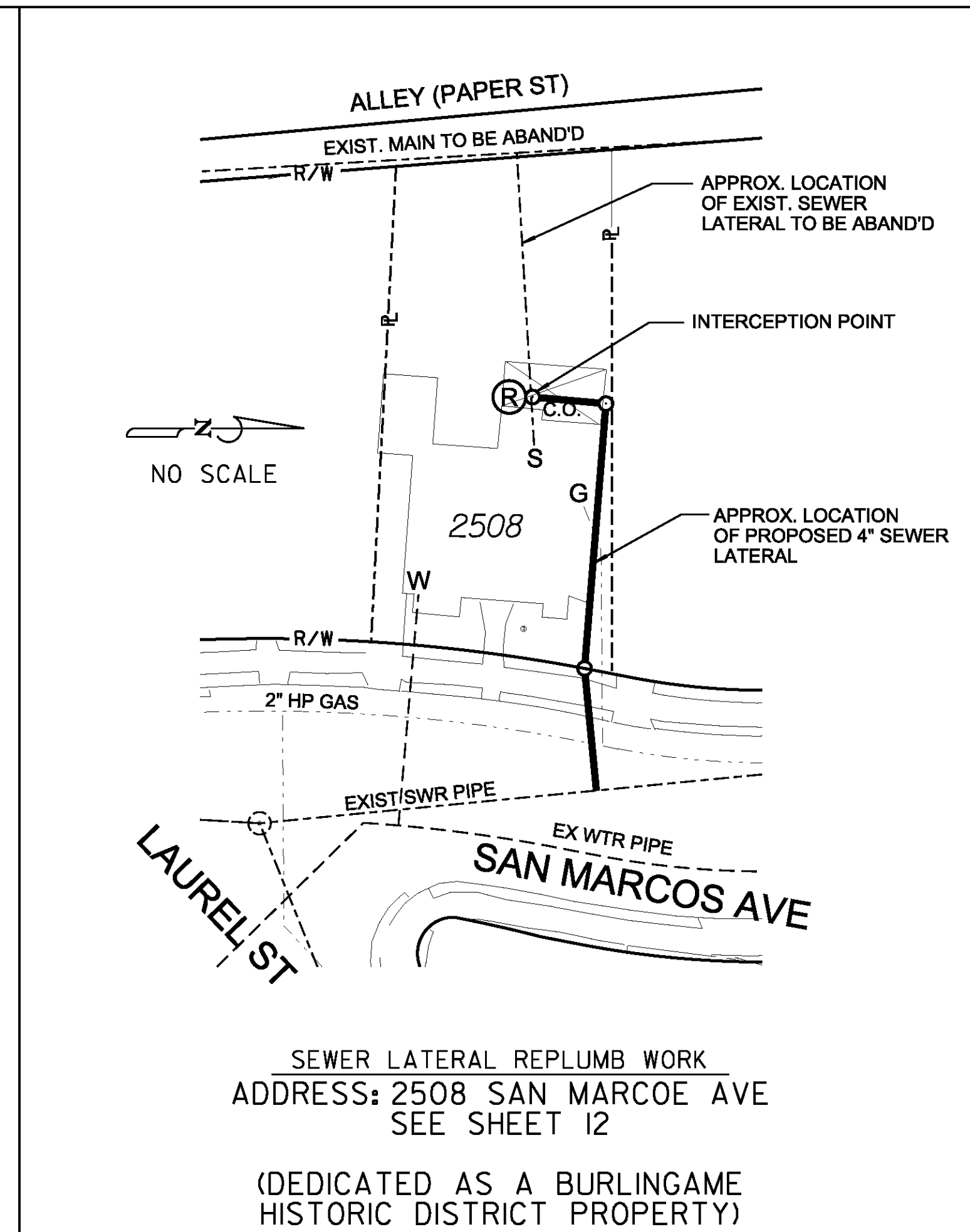
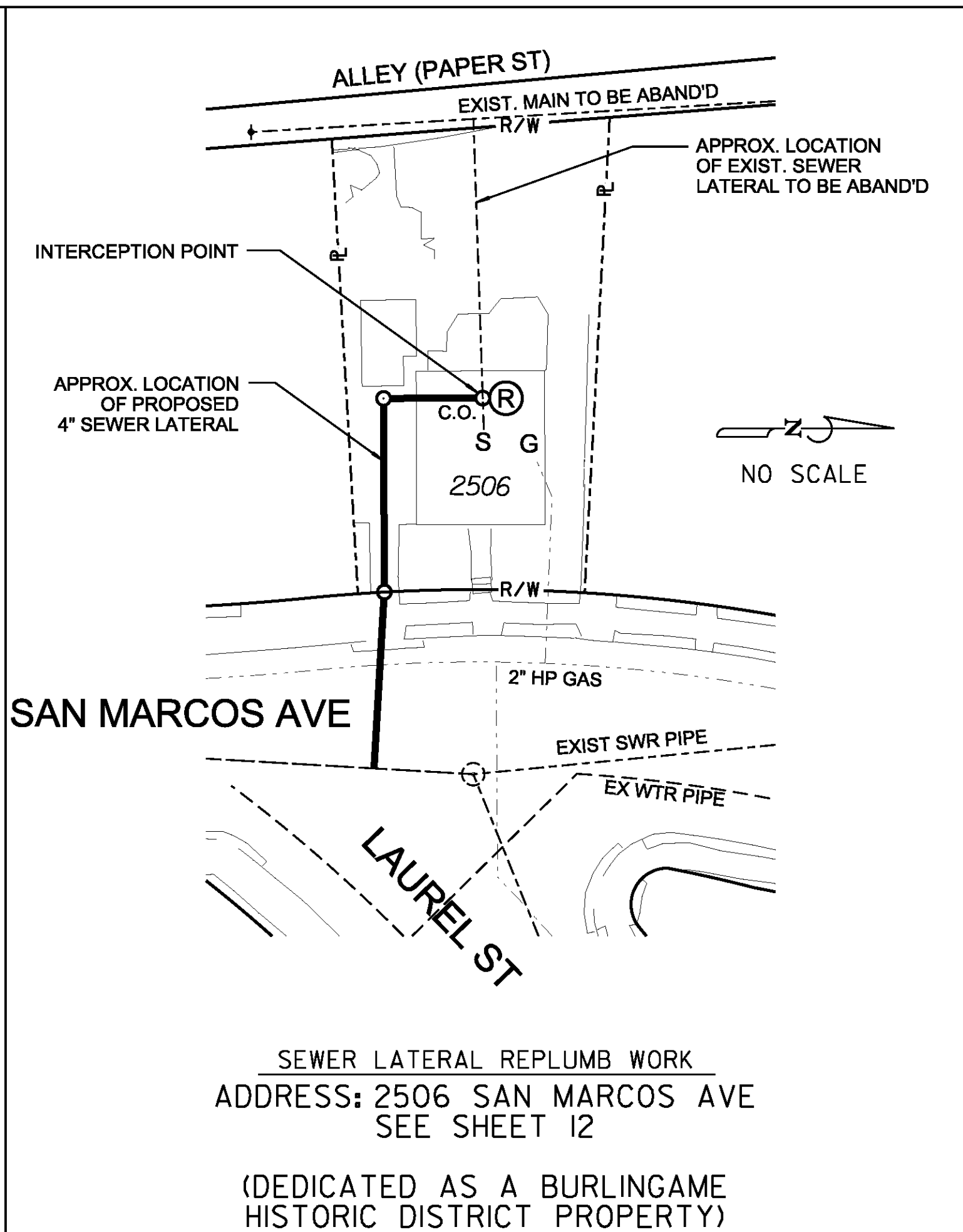
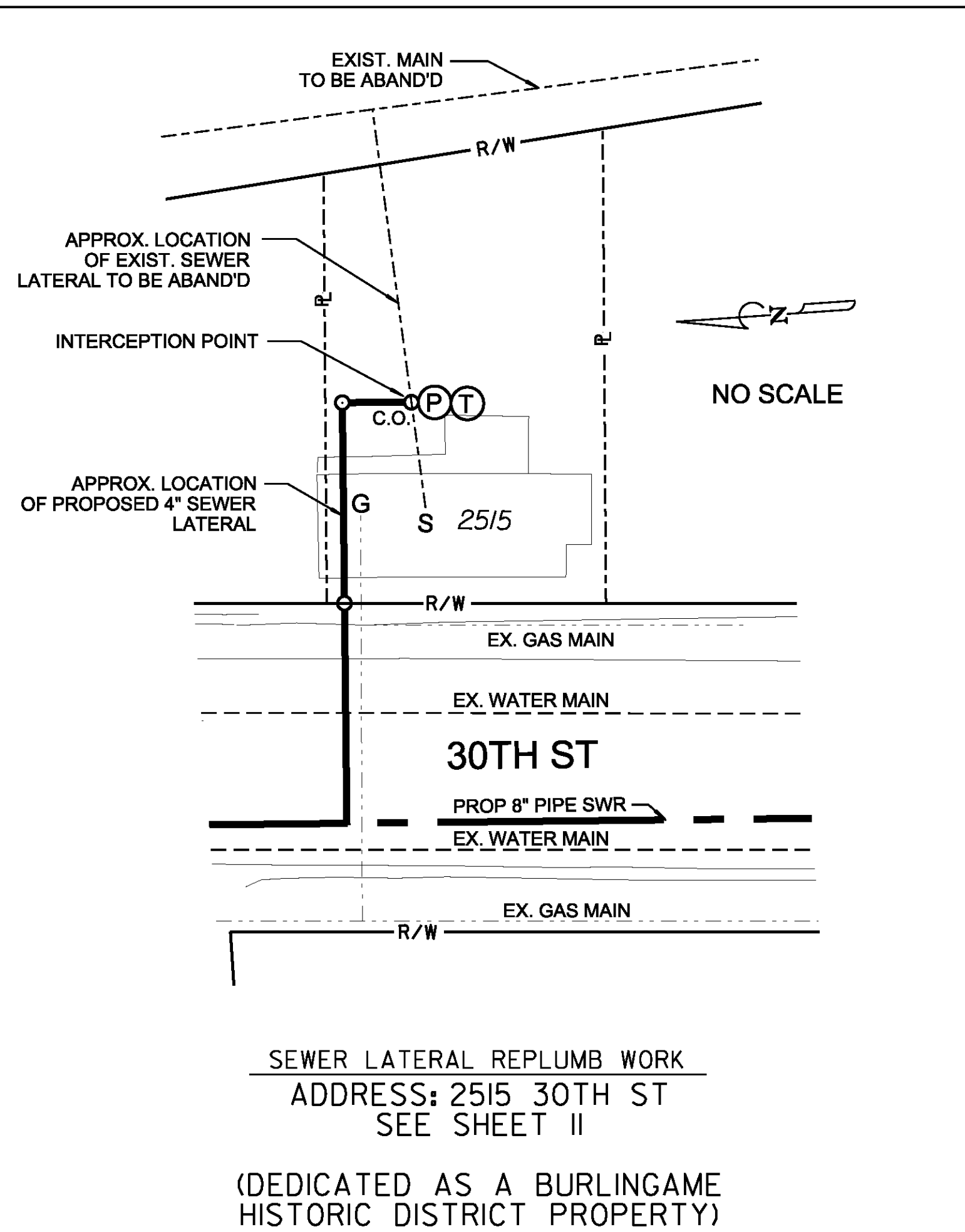

KEY MAP
NO SCALE

C-17

SEWER GROUP 691			
REPLUMB DETAILS			
CITY OF SAN DIEGO, CALIFORNIA PUBLIC WORKS DEPARTMENT SHEET 18 OF 21 SHEETS		WATER WBS - SEWER WBS B-00446	
APPROVED BY: <i>Rania Amen</i> FOR CITY ENGINEER RANIA AMEN DATE: 7/14/2014		PROJECT MANAGER JERICHO GALLARDO	
DESIGNED BY: JOSELITO QUINTO PROJECT ENGINEER		CHECKED BY: JOSELITO QUINTO PROJECT ENGINEER	
DESCRIPTION	BY	APPROVED	DATE
ORIGINAL	JG/JC		
SEE EACH SHEET CC527 COORDINATE		SEE EACH SHEET CC583 COORDINATE	
CONTRACTOR		DATE STARTED	
INSPECTOR		DATE COMPLETED	
		32506-18-D	

REPLUMB DETAILS

CANYON AREA

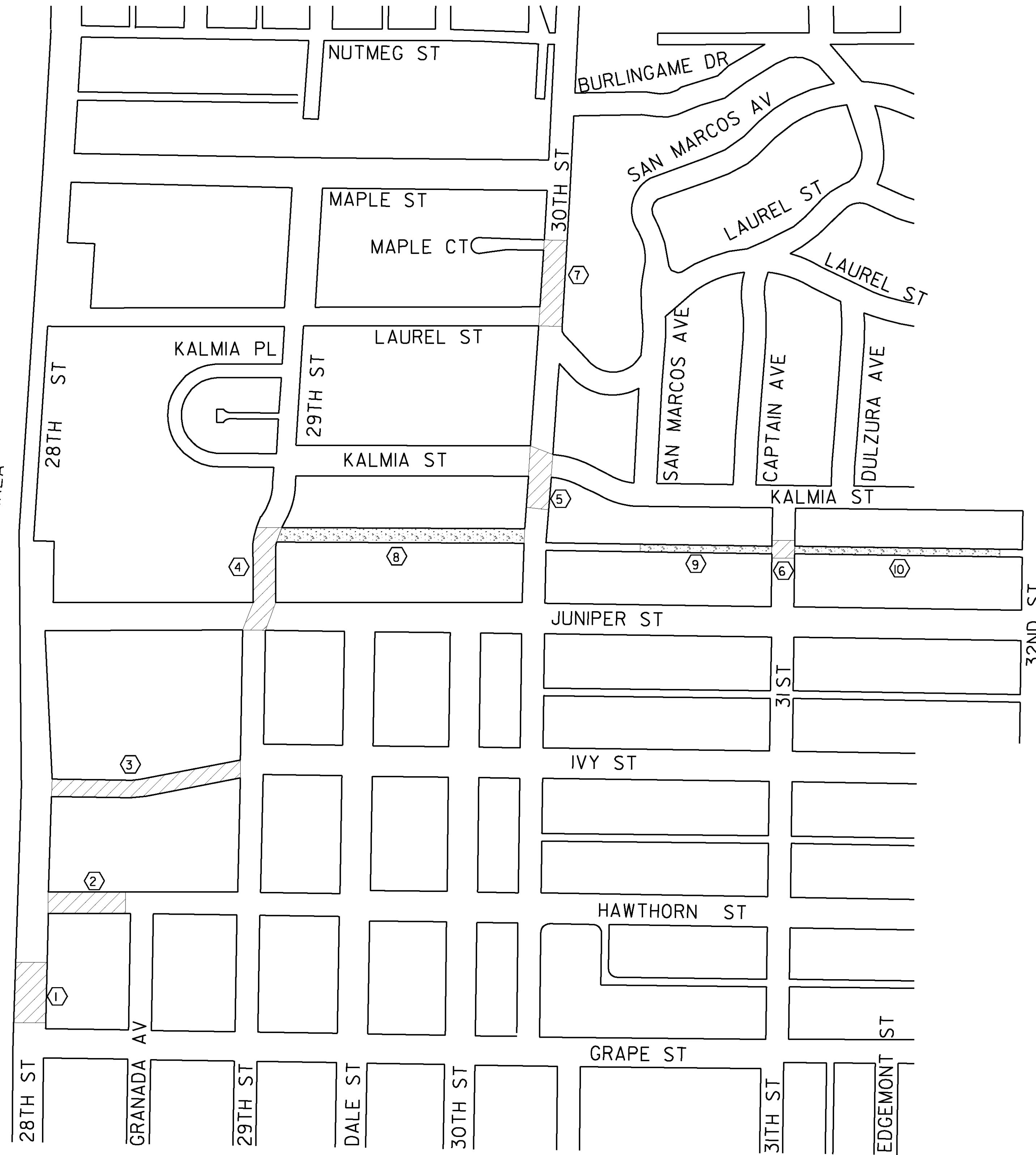

LEGEND	
	APPROXIMATE LOCATION OF SLURRY SEAL
	APPROX. LIMITS OF CONCRETE PAVEMENT
	LOCATION PER PAVING SCHEDULE NOTES (THIS SHEET) COLD MILLING ASPHALT CONCRETE PAVEMENT; SDG-106

PAVING SCHEDULE NOTES						
NO.	LOCATION	RESTORATION REQUIRED	STATION	STATION	WIDTH	APPROX. AREA
1	28TH ST	SLURRY SEAL	2+80.00	4+44.50	74'	12,173.00
2	HAWTHORN ST	SURRY SEAL	1+41.71	3+10.00	34'	5,721.86
3	IVY ST	SLURRY SEAL	3+47.56	8+77.02	36'	19,080.56
4	29TH ST	SLURRY SEAL	8+40.65	11+04.80	40'	10,566.00
5	30TH ST	SLURRY SEAL	0+68.00	2+07.01	40'	5560.40
6	31 ST	SLURRY SEAL	4+19.50	4+79.50	21'	1260.00
7	30TH ST	SLURRY SEAL	0+84.00	3+06.20	40'	8,888.00
8	ALLEY - BLOCK 8 / 88	CONCRETE	11+30.47	17+74.45	20'	12,895.36
9	ALLEY - BLOCK A / 8	CONCRETE	0+90.00	4+19.50	21'	9019.50
10	ALLEY - BLOCK B / 7	CONCRETE	4+79.50	10+93.60	21'	12,896.10
TOTAL AREA OF SLURRY SEAL						62,820.32 SF
TOTAL AREA OF RESURFACE CONCRETE						34,810.96 SF

C-18

SEWER GROUP 691
STREET RESURFACING

CITY OF SAN DIEGO, CALIFORNIA PUBLIC WORKS DEPARTMENT SHEET 19 OF 21 SHEETS		WATER WBS - SEWER WBS B-00446
APPROVED BY: <i>Rania Amen</i> FOR CITY ENGINEER RANIA AMEN DCE NAME	DATE: 7/14/2014	PROJECT MANAGER: JERICHO GALLARDO
DESIGNED BY: JOSELITO QUINTO PROJECT ENGINEER		SEE EACH SHEET CCS27 COORDINATE
		SEE EACH SHEET CCS83 COORDINATE
CONTRACTOR: _____	DATE STARTED: _____	32506-19-D
INSPECTOR: _____	DATE COMPLETED: _____	

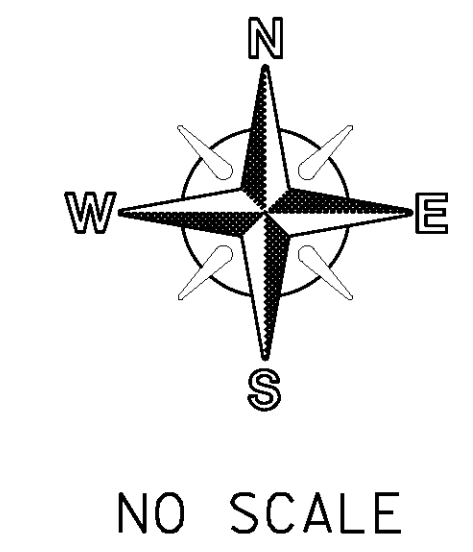

STREET RESURFACING

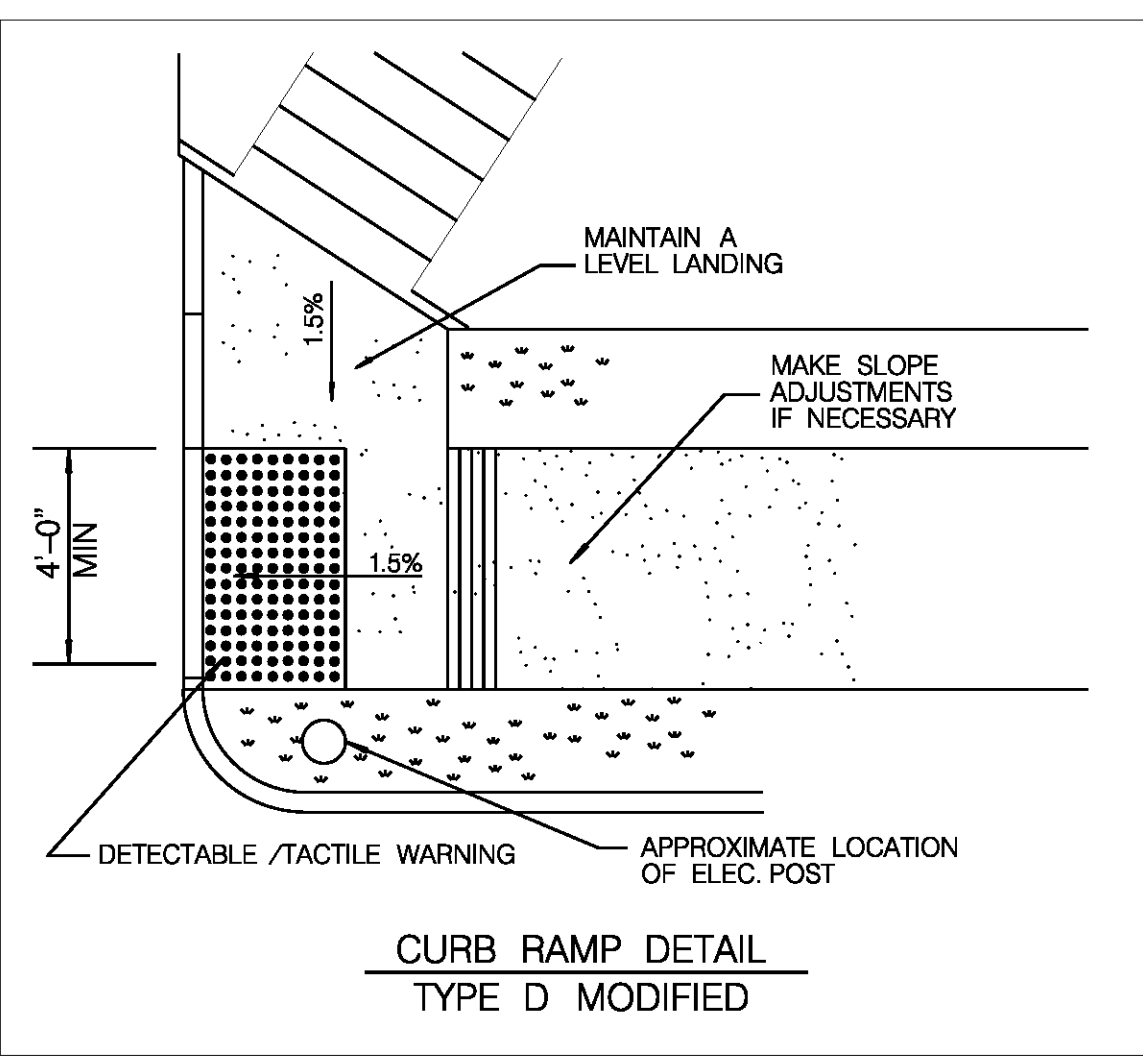
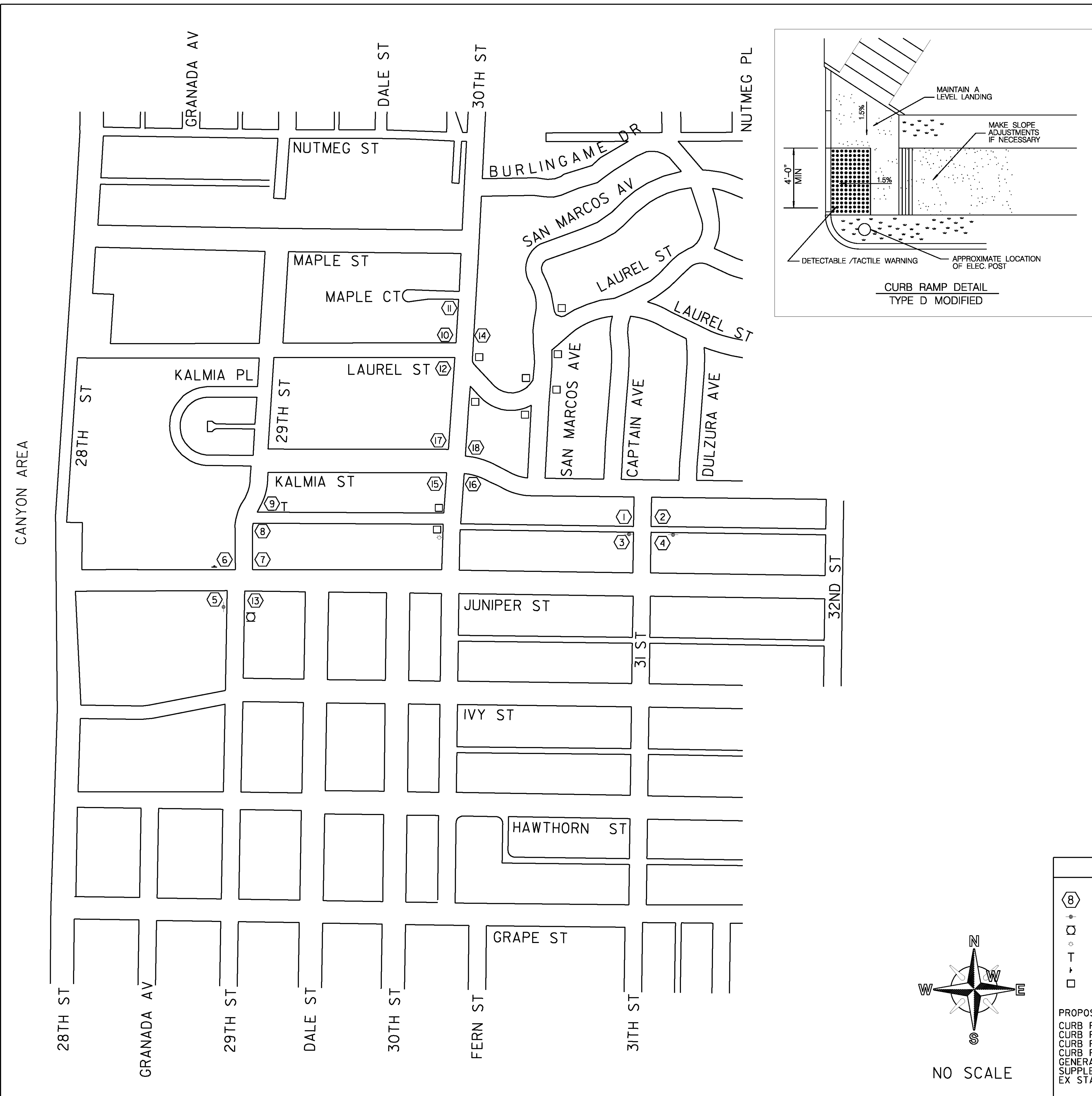

CURB RAMP NOTES TABLE									
LOCATION NO.	RAMP TYPE	NEW	REPLACEMENT	HISTORIC STAMPS	TRUNCATED DOME MATERIAL		CONSTRAINTS	COMMENTS / MODIFICATIONS	
					• STAINLESS STEEL	• OTHER			
1	D	X				X		1) NEXT TO DRIVEWAY 2) CONTRACTOR TO MATCH EX. SIDEWALK CONC. COLOR	
2	D		X			X		1) MATCH SIDEWALK CONCRETE COLOR 2) ELECTRIC POLE 3) ELECTRIC PANEL	
3	D	X		1		X		1) ELECTRIC POLE 3) ELECTRIC PANEL	
4	D	X		1		X		1) ELECTRIC POLE 3) ELECTRIC PANEL	
5	A		X			X		1) CURB ADDRESS NUMBER 2) CURB PAINTED RED 3) ELECTRIC POLE	
6	A	X		2		X		1) CURB PAINTED RED 2) STOP SIGN 3) DEAD END SIGN	
7	A		X	1		X		1) BENCHMARK	
8	D	X				X		1) NEXT TO COLORED CONC. STAIRCASE 2) ELEC. POLE 2) SEE DETAIL LEFT SIDE	
9	D	X				X		1) CLEAR ANY LANDSCAPE OVERGROWTH ALONG SIDEWALK U TO 7'-0"	
10	A		X			X		1) NEXT TO FIRE HYDRANT	
11	D		X			X		1) STOP SIGN 2) COX VAULT	
12	A		X			X		1) NEXT TO STOP SIGN AND FIRE HYDRANT	
13	A		X			X		1) ELECTRIC POLE	
14	B	X				X		1) TELEPHONE AND ELECTRICAL STRUCTURE	
15	A		X			X		1) NEXT TO STOP SIGN AND ELECTRIC POLE	
16	A		X			X		1) NEXT TO FIRE HYDRANT 2) CONTRACTOR TO MATCH EX SIDEWALK CONC COLOR	
17	A		X	1		X		1) NEXT TO WOODEN FENCE	
18	A		X			X		1) NEXT TO STOP SIGN	

• THE DETECTABLE WARNING TILES SHALL BE PER THE CITY'S APPROVED MATERIALS LIST

NOTES:

- CONTRACTOR TO NOTIFY SURVEYING 30 DAYS PRIOR TO REMOVAL OF SIDEWALK FOR CURB RAMP CONSTRUCTION TO RELOCATE ANY SURVEY MARKERS.
- ANY EXISTING CONTRACTOR STAMPS OR STREET NAME IMPRESSIONS FROM THE HISTORICAL INVENTORY MUST BE PRESERVED PER SECTION 303-5.1.4 OF THE CONTRACT SPECIFICATIONS, THE SSP, AND THE MND.
- THE CONTRACTOR SHALL DUPLICATE THE EXISTING SURROUNDING SCORE PATTERN AND ROSE-COLORED CONCRETE SIDEWALKS, CURBS AND DRIVEWAYS PER SECTION 303-5.1.5 OF THE CONTRACT SPECIFICATIONS.
- TRUNCATED DOME COLOR WITHIN THE BOUNDARIES OF THE BURLINGAME HISTORIC DISTRICT SHALL BE DARK GREY, UNLESS THIS COLOR DOES NOT COMPLY WITH THE CONTRAST REQUIREMENTS OF THE AMERICANS WITH DISABILITIES ACT (ADA). AN ADA CONTRAST STUDY SHALL BE PERFORMED BEFORE CONSTRUCTION.
- CONTRACTOR TO ADJUST LIMIT LINES BEFORE EACH CURB RAMP.
- LIMIT LINES TO BE RESTRIPE WITH 12" WIDE WHITE THERMOPLASTIC.

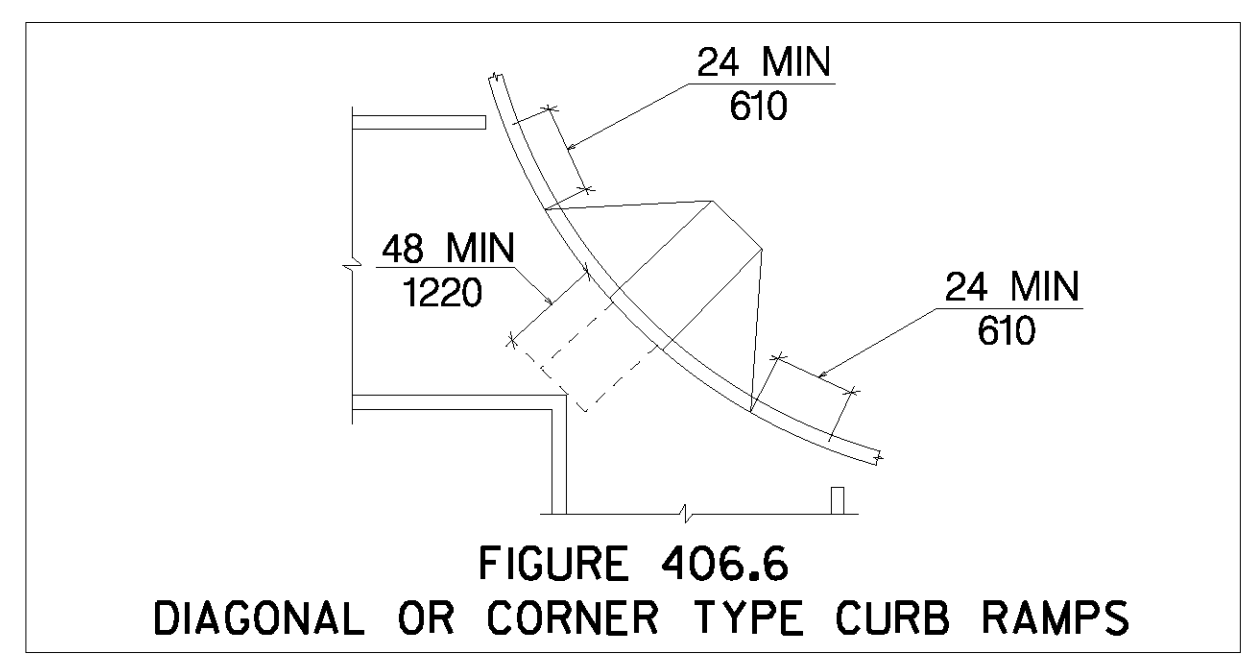

LEGEND

- Ⓢ CURB RAMP NO's
- EX UTILITY POLE
- EX FIRE HYDRANT
- ◊ EX STREET LIGHT
- T EX TREE
- † EX STREET SIGN
- EX CURB RAMP

PROPOSED CURB RAMPS PER STANDARD DRAWINGS:

- CURB RAMP A & B SDG-132
- CURB RAMP - TYPE C1 SDG-134
- CURB RAMP - TYPE C2 SDG-135
- CURB RAMP - TYPE D SDG-136
- GENERAL CURB RAMP NOTES & SUPPLEMENTAL DETAILS SDG-130
- EX STAMP/IMPRESSION PLACEMENT SDG-115

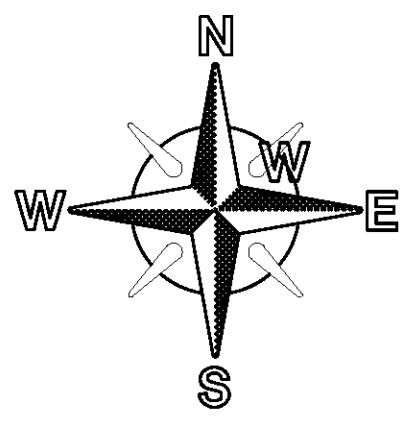

NO SCALE



SEWER GROUP 691
CURB RAMP LOCATION

CITY OF SAN DIEGO, CALIFORNIA
PUBLIC WORKS DEPARTMENT
SHEET 20 OF 21 SHEETS

APPROVED: *Rania Amen* 7/14/2014
FOR CITY ENGINEER: RANIA AMEN
DATE: 7/14/2014

WATER WBS: -
SEWER WBS: B-00446

DESIGNED BY: JERICO GALLARDO
PROJECT MANAGER

CHECKED BY: JOSE LITO QUINTO
PROJECT ENGINEER

DESCRIPTION	BY	APPROVED	DATE	FILMED
ORIGINAL	JG/JG			

SEE EACH SHEET
CC527 COORDINATE

SEE EACH SHEET
CC583 COORDINATE

CONTRACTOR: _____ DATE STARTED: _____
INSPECTOR: _____ DATE COMPLETED: _____

32506-20-D

C-19

CURB RAMP LOCATION

HORIZONTAL ALIGNMENT COORDINATE INDEX SHEET

] ALIGNMENT NAME: SHEET 02
] ALIGNMENT DESCRIPTION: 28TH STREET

STATION	NORTHING	EASTING
ELEMENT: LINEAR		
POB (100)	1+00.00	1845662.44 6289898.08
PI (101)	1+29.00	1845635.18 6289888.19
TANGENTIAL DIRECTION: 3.49		
TANGENTIAL LENGTH: 29.00		

ELEMENT: LINEAR		
PI (101)	1+29.00	1845635.18 6289888.19
PI (102)	2+90.00	1845474.17 6289885.88
TANGENTIAL DIRECTION: 3.16		
TANGENTIAL LENGTH: 161.03		

ELEMENT: LINEAR		
PI (102)	2+90.00	1845474.17 6289885.88
POE (103)	3+95.00	1845369.18 6289884.45
TANGENTIAL DIRECTION: 3.16		
TANGENTIAL LENGTH: 105.00		

] ALIGNMENT NAME: SHEET 03
] ALIGNMENT DESCRIPTION: HAWTHORN ST

STATION	NORTHING	EASTING
ELEMENT: LINEAR		
POB (100)	1+00.00	1845662.44 6289898.08
PI (104)	2+03.15	1845660.67 6290001.22
TANGENTIAL DIRECTION: 1.59		
TANGENTIAL LENGTH: 103.15		

ELEMENT: LINEAR		
PI (104)	2+03.15	1845660.67 6290001.22
POE (105)	2+99.91	1845658.98 6290097.96
TANGENTIAL DIRECTION: 1.59		
TANGENTIAL LENGTH: 96.75		

] ALIGNMENT NAME: SHEET 04
] ALIGNMENT DESCRIPTION: 28TH STREET / IVY STREET

STATION	NORTHING	EASTING
ELEMENT: LINEAR		
POB (106)	1+00.00	1845754.04 6289818.80
PI (107)	1+42.92	1845781.92 6289851.44
TANGENTIAL DIRECTION: 0.86		
TANGENTIAL LENGTH: 42.92		

ELEMENT: LINEAR		
PI (107)	1+42.92	1845781.92 6289851.44
PI (108)	2+13.08	1845852.08 6289852.24
TANGENTIAL DIRECTION: 0.01		
TANGENTIAL LENGTH: 70.16		

ELEMENT: LINEAR		
PI (108)	2+13.08	1845852.08 6289852.24
PI (109)	3+26.56	1845965.55 6289853.53
TANGENTIAL DIRECTION: 0.01		
TANGENTIAL LENGTH: 113.48		

ELEMENT: LINEAR		
PI (109)	3+26.56	1845965.55 6289853.53
PI (110)	5+83.68	1845961.22 6290110.62
TANGENTIAL DIRECTION: 1.59		
TANGENTIAL LENGTH: 257.12		

ELEMENT: LINEAR		
PI (110)	5+83.68	1845961.22 6290110.62
POE (111)	8+23.00	1845995.73 6290347.43
TANGENTIAL DIRECTION: 1.43		
TANGENTIAL LENGTH: 239.32		

] ALIGNMENT NAME: SHEET 05-06
] ALIGNMENT DESCRIPTION: ALLEY BLK A, B, 8, AND 7

STATION	NORTHING	EASTING
ELEMENT: LINEAR		
POB (112)	1+00.00	1846586.62 6291470.95
PI (113)	4+49.27	1846581.87 6291820.19
TANGENTIAL DIRECTION: 1.58		
TANGENTIAL LENGTH: 349.27		

ELEMENT: LINEAR		
PI (113)	4+49.27	1846581.87 6291820.19
PI (114)	7+49.70	1846577.45 6292120.58
TANGENTIAL DIRECTION: 1.59		
TANGENTIAL LENGTH: 300.43		

ELEMENT: LINEAR		
PI (114)	7+49.70	1846577.45 6292120.58
POE (115)	10+54.70	1846572.85 6292425.55
TANGENTIAL DIRECTION: 1.59		
TANGENTIAL LENGTH: 305.00		

] ALIGNMENT NAME: SHEET 07-08
] ALIGNMENT DESCRIPTION: JUNIPER STREET

STATION	NORTHING	EASTING
ELEMENT: LINEAR		
POB (116)	1+00.00	1846388.88 6289695.24
PI (117)	1+61.78	1846387.64 6289757.01
TANGENTIAL DIRECTION: 1.59		
TANGENTIAL LENGTH: 61.78		

ELEMENT: LINEAR		
PI (117)	1+61.78	1846387.64 6289757.01
PI (118)	2+00.79	1846415.74 6289784.06
TANGENTIAL DIRECTION: 0.77		
TANGENTIAL LENGTH: 39.01		

ELEMENT: LINEAR		
PI (118)	2+00.79	1846415.74 6289784.06
PI (119)	3+81.04	1846421.39 6289964.22
TANGENTIAL DIRECTION: 1.54		
TANGENTIAL LENGTH: 180.25		

ELEMENT: LINEAR		
PI (119)	3+81.04	1846421.39 6289964.22
PI (120)	5+38.89	1846418.67 6290122.05
TANGENTIAL DIRECTION: 1.59		
TANGENTIAL LENGTH: 157.85		

ELEMENT: LINEAR		
PI (120)	5+38.89	1846418.67 6290122.05
PI (121)	8+70.65	1846413.01 6290453.76
TANGENTIAL DIRECTION: 1.59		
TANGENTIAL LENGTH: 331.76		

ELEMENT: LINEAR		
PI (121)	8+70.65	1846413.01 6290453.76
PI (122)	10+94.79	1846637.13 6290457.01
TANGENTIAL DIRECTION: 0.01		
TANGENTIAL LENGTH: 224.15		

ELEMENT: LINEAR		
PI (122)	10+94.79	1846637.13 6290457.01
PI (123)	14+20.19	1846631.30 6290782.35
TANGENTIAL DIRECTION: 1.59		
TANGENTIAL LENGTH: 325.40		

ELEMENT: LINEAR		
PI (123)	14+20.19	1846631.30 6290782.35
POE (124)	17+80.24	1846625.35 6291142.35
TANGENTIAL DIRECTION: 1.59		
TANGENTIAL LENGTH: 360.05		

] ALIGNMENT NAME: SHEET 09
] ALIGNMENT DESCRIPTION: 30TH STREET

STATION	NORTHING	EASTING
ELEMENT: LINEAR		
POB (125)	1+00.00	1846815.55 6291170.68
POE (126)	1+97.01	1846718.54 6291170.16
TANGENTIAL DIRECTION: 3.15		
TANGENTIAL LENGTH: 97.01		

] ALIGNMENT NAME: SHEET 10
] ALIGNMENT DESCRIPTION: EASEMENT BLK H, N

STATION	NORTHING	EASTING
ELEMENT: LINEAR		
POB (127)	1+00.00	1847844.33 6291367.26
PI (128)	1+93.12	1847751.73 6291357.40
TANGENTIAL DIRECTION: 3.25		
TANGENTIAL LENGTH: 93.12		

ELEMENT: LINEAR		
PI (128)	1+93.12	1847751.73 6291357.40
POE (129)	3+20.42	1847633.90 6291309.23
TANGENTIAL DIRECTION: 3.53		
TANGENTIAL LENGTH: 127.29		

] ALIGNMENT NAME: SHEET 11
] ALIGNMENT DESCRIPTION: 30TH STREET

STATION	NORTHING	EASTING
ELEMENT: LINEAR		
POB (130)	1+00.00	1847196.91 6291199.21
POE (131)	2+90.20	1847386.78 6291210.42
TANGENTIAL DIRECTION: 0.06		
TANGENTIAL LENGTH: 190.20		

C-20

SEWER GROUP 691			
COORDINATE INDEX SHEET			
CITY OF SAN DIEGO, CALIFORNIA PUBLIC WORKS DEPARTMENT SHEET 21 OF 21 SHEETS		WATER WBS - SEWER WBS B-00446	
APPROVED BY: <i>[Signature]</i> FOR CITY ENGINEER RANIA AMEN DCE NAME		DATE: 7/14/2014	
DESIGNED BY: <i>[Signature]</i> JOSELITO GUINTO PROJECT ENGINEER		CHECKED BY: <i>[Signature]</i> JOSELITO GUINTO PROJECT ENGINEER	
DESCRIPTION	BY	APPROVED	DATE
ORIGINAL	JG/JG		
CONTRACTOR _____ DATE STARTED _____			
INSPECTOR _____ DATE COMPLETED _____			

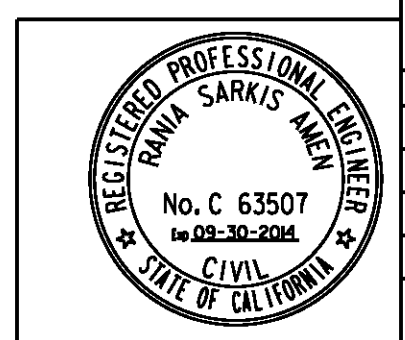

COORDINATE INDEX SHEET