



STRAPPING REQUIREMENTS FOR
Water Heaters

CITY OF SAN DIEGO PLANNING & DEVELOPMENT REVIEW DEPARTMENT
INSPECTION SERVICES: 9601 RIDGEHAVEN CT. SUITE 220, SAN DIEGO, CA 92123
Call (858) 492-5070 for information and (858) 581-7111 to schedule inspections.

INFORMATION
BULLETIN
207
APRIL 1999

The State of California requires that all water heaters in our area be anchored or strapped to resist movement during an earthquake. This can be accomplished by installing any of the over-the-counter products especially made for restraining water heaters (example 1) or you can make your own out of a heavy-duty metal strap material (Example 2).

It is required that at least two restraints are used, with one in the upper one-third and one in the lower

one-third of the water heater. Fasten of the anchor or strap to the structure, use a screw not less than 1/4" diameter with a minimum penetration of 1 1/2" into a wood stud of the wall, with a washer between the head of the screw and the restraint.

Below are examples of acceptable methods for restraining a water heater.

Note: A plumbing and gas permit is required any time a water heater is replaced.

Example 1

These types of restraints are over-the-counter products sold at your local hardware store.

Drill pilots on center line of stud, insert screws through punched holes in strap. Use washers.

The lower strap must be a minimum of 4" above the control unit.

This 18" stand is required for heaters installed in a garage location.

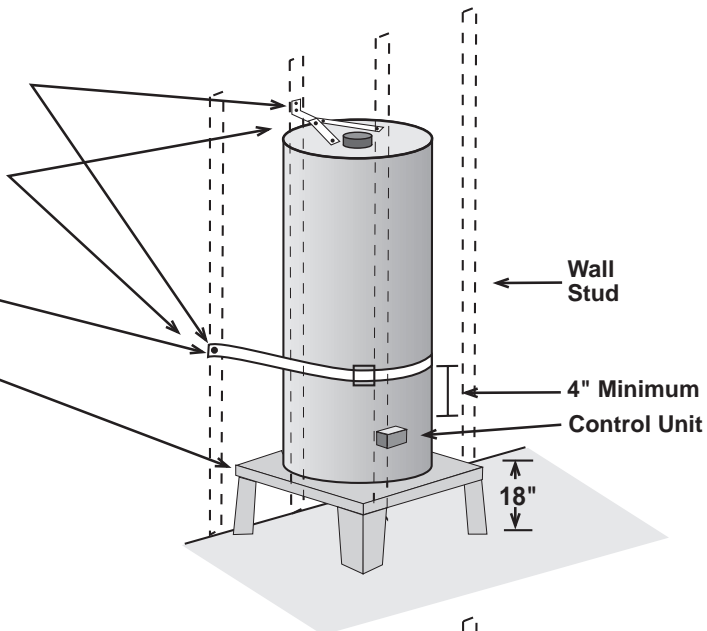

Example 2

Minimum 22 Gauge metal strap material installed within the top 1/3 of the heater and the bottom 1/3 of the heater.

Drill pilots on center line of stud, insert screws through punched holes in strap.

Use minimum 1/4" screws with minimum 1 1/2" penetration. Use washers.

The lower strap must be a minimum of 4" above the control unit.

This 18" stand is required for heaters installed in a garage location.

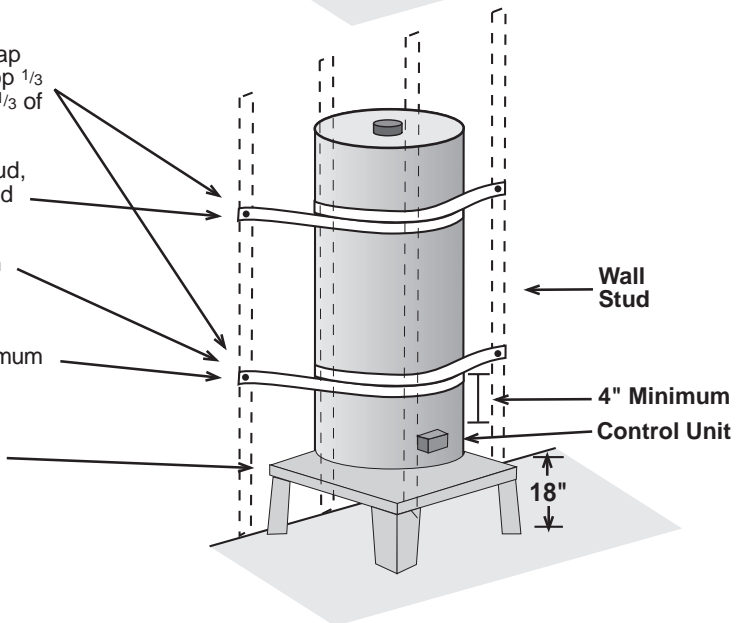

This information is available on alternative formats for persons with disabilities.
To request this bulletin in alternative format, call (619) 446-5446 or (800) 735-2929 (TT).