



THE CITY OF SAN DIEGO

HOW TO OBTAIN A NEIGHBORHOOD USE PERMIT FOR A

Sidewalk Cafe

CITY OF SAN DIEGO DEVELOPMENT SERVICES
1222 FIRST AVENUE, MS 302 SAN DIEGO, CA 92101-4101
CALL (619) 446-5300 FOR APPOINTMENTS AND (619) 446-5000 FOR INFORMATION

INFORMATION
BULLETIN

523

OCTOBER 2010

This information bulletin describes the minimum submittal requirements for a Sidewalk Cafe Neighborhood Use Permit application. If the proposed sidewalk cafe is located in the Centre City Development Corporation (CCDC) planning area, please contact CCDC at (619) 235-2200 to process your Neighborhood Use Permit for a sidewalk cafe. To find out if your project is in the CCDC planning area, which includes most of the downtown San Diego area, call our general information number at (619) 446-5000 or CCDC at (619) 235-2200. If the proposed sidewalk cafe is within the Coastal Overlay Zone, a Coastal Development Permit may also be required (see Land Development Code Section 126.0704).

I. WHAT IS A SIDEWALK CAFE?

A sidewalk cafe is an area adjacent to a street level eating and/or drinking establishment, and is located on the sidewalk area within the public right-of-way. This area is used exclusively for dining and drinking. The sidewalk cafe area is separated from the pedestrian area of the sidewalk and is enclosed by railings or landscaping in planter boxes, or a combination of both. Contained within the area of the sidewalk cafe may be such items as canopies, awnings and umbrellas.

II. SUBMITTAL REQUIREMENTS

Phone (619) 446-5300 to schedule a submittal appointment for a Sidewalk Cafe Neighborhood Use Permit. At this appointment, provide information in the quantities shown below.

A. Application Package

Provide one copy of the following documents:

1. **General Application (DS-3032)**
2. **Supplemental Discretionary Application (DS-3035)**
3. **Deposit Account/Financially Responsible Party (DS-3242)**
4. **Ownership Disclosure Statement (DS-318)**, Signed by the adjacent street level business owner of the property proposing the sidewalk cafe.
5. **Grant Deed** - A copy of the Grant Deed is required to provide proof of current ownership for the property proposing the sidewalk cafe.

B. Photographic Survey

Provide one set of photographs showing the

Documents Referenced in this Information Bulletin

- **Coastal Development Permit, (SDMC Section 126.0704)**
- **Information Bulletin 502, Fee Schedule for Construction Permits - Grading & Public Right-of-Way**
- **Information Bulletin 503, Fee Schedule for Development & Policy Approvals/Permits**
- **Information Bulletin 512, How to Obtain Public Noticing Information**
- **Ownership Disclosure Statement, DS-318**
- **General Application, DS-3032**
- **Supplemental Discretionary Application, DS-3035**
- **Encroachment and Maintenance Removal Agreement, DS-3237**
- **Deposit Account/Financially Responsible Party, DS-3242**

area for the proposed sidewalk cafe. The photographs should be in color (minimum size 3" x 5" and maximum size of 8" x 10"), placed in an envelope (not mounted), and include a map with key indicating the location and direction each photograph was taken. In addition to print photos, provide a CD-R containing digital photos submitted for the "Photographic Survey." The photos should be saved in the .jpg format, numbered consistently with the provided key map, and sized no smaller than 3" by 5" and no larger than 8" x 10".

C. Public Notice Package

A public notice package is required as part of your submittal. This will be used to notify adjacent tenants and property owners of the proposed sidewalk cafe. See Information Bulletin 512, "How to Obtain Public Noticing Information" for more details.

D. Plans

Plans must be fully dimensioned and no larger than 8 1/2 inches by 11 inches. Provide eight (8) sets of plans, to include:

1. **Development Summary** - Provide, in a table format, the following information on the first page of the plans:
 - a. Provide a bullet point narrative that details the project's complete scope of work,

Printed on recycled paper. Visit our web site at www.sandiego.gov/development-services.
Upon request, this information is available in alternative formats for persons with disabilities.

- including all existing and proposed improvements, any proposed development regulation deviations, and the required permits/approvals.
- b. Show the Project Team - List name and phone number of all consultants including engineers, architects, designers and contractors.
 - c. Show legal description and Assessor Parcel Number(s) for the property on which the development is proposed.
 - d. Show owner's name and address.
 - e. Show type of construction of the adjacent street-level business per the California Building Code.
 - f. Show occupancy classification of the adjacent street-level business per the California Building Code.
 - g. List the name and type of the adjacent street-level business that the sidewalk cafe will be serving. Indicate if the business is existing or proposed.
 - h. Provide the total square footage of the sidewalk cafe area.
 - i. Show the zoning designation and all overlay zone designations.

2. Site Plan

A site plan is a dimensioned drawing which shows the general layout of the sidewalk area and building frontage. See Figure 1 for a sample sidewalk cafe site plan.

- a. Street, curb, sidewalk, property lines and all existing/proposed improvements in the sidewalk area.
- b. Frontage of the building or tenant space serving the proposed sidewalk cafe and adjacent buildings or tenant spaces.
- c. Boundaries of the sidewalk cafe.
- d. Dimension the distance between the sidewalk cafe and the entrance to the adjacent commercial business (8-foot minimum).
- e. Dimension the distance between the railing of the sidewalk cafe and the curb. A minimum of 8'-0" of paved sidewalk must be provided for sufficient pedestrian traffic.
- f. Dimension the distance between any obstruction (parking meters, lights, signs, mail boxes, trees, tree grates, etc.) In the sidewalk area to the railing of the sidewalk cafe. A minimum distance of 8'-0" is required for pedestrian traffic.
- g. Plans must reflect that the direction and extent of swing of gates or other objects placed within the sidewalk cafe area do not project beyond the delineated perimeter.

- h. Plans must establish that the approved means of egress from the existing building are not blocked, diminished or in any way altered as a result of the new sidewalk cafe.
- i. Dimension clearances for disabled access within the sidewalk cafe area.

3. Method of Attachment

Show the method used to attach the railing of the sidewalk cafe to the sidewalk. See Figure 2 for a sample drawing of a standard method of rail attachment.

4. Elevation Plan

This is a dimensioned drawing of the face of the building which can be seen from the sidewalk. See Figure 3 for a sample elevation drawing. Include the following information on the elevation drawing:

- a. Front view of the sidewalk cafe and adjacent businesses.
- b. Type of sidewalk cafe enclosure used, such as railings, planters (maximum height of three (3) feet).
- c. Dimension height of enclosure.
- d. Description of furniture to be used in the sidewalk cafe.
- e. Umbrellas, awnings, canopies or outdoor heaters (propane or piped gas type), if proposed. Clearance to combustibles from the heater must be shown. A minimum distance of 7'-0" is required between the bottom of any umbrella or awning and the sidewalk.
- f. Dimension the distance between the proposed sidewalk cafe and any adjacent sidewalk cafes.
- g. Indicate any proposed lighting in the sidewalk cafe area.
- h. Show all the proposed and existing signs related to sidewalk cafe and the restaurant.

5. Deposit / Fees

These must be paid at the time of submittal. See Information Bulletin 503, "Fee Schedule for Development & Policy Approvals/Permits."

III. SEPARATE PERMITS REQUIRED

A Public Right-of-Way Permit will be required before the Neighborhood Use Permit for a sidewalk cafe can be finalized. This requires a separate fee for the inspection of the sidewalk cafe and the recording of the Encroachment and Maintenance Removal Agreement (see Information Bulletin 502, "Fee Schedule for Construction Permits - Grading and Public Right-of-Way").

A building permit is not required unless the proposal includes awnings, canopies, lighting for the sidewalk cafe, or signs. No signs are permitted on the sidewalk cafe except that the name and type of establishment may appear on the

umbrellas or valance of an awning not to exceed four (4) square feet per side. A sign permit is not required for the 4 square feet permitted on the umbrellas or awnings. A separate sign permit is required for any signs on the building frontage.

Figure 1 / Sample Sidewalk Cafe Site Plan

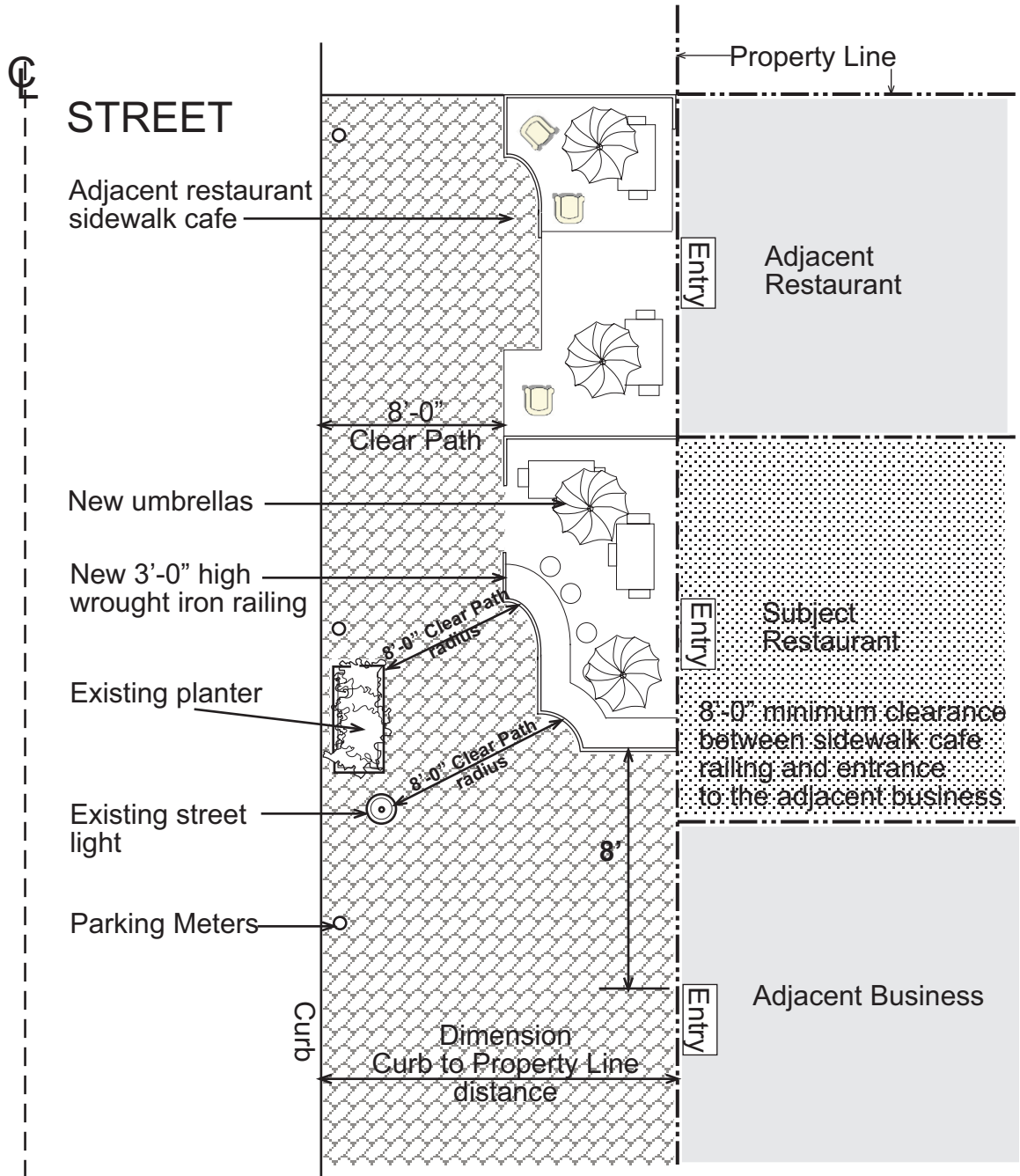

Property Owner or Tenant Information
Mr. & Mrs. Smith
1234 Elm St.
San Diego, CA 92100

Sidewalk Cafe Address
5678 Maple St.
San Diego, CA 92100

Legal Description
Lot 1213, Block 4
City Heights Subdivision
Map 5678
APN # 123-456-07

Figure 2 / Standard Method of Rail Attachment

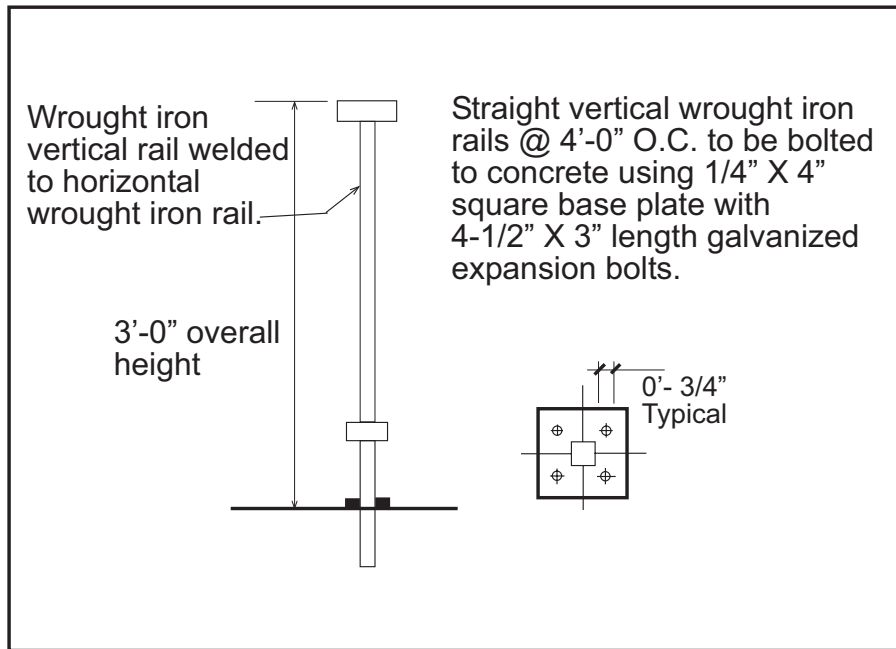

Figure 3 / Sample Sidewalk Cafe Elevation

