

OLD LANGUAGE: ~~STRIKEOUT~~
NEW LANGUAGE: DOUBLE UNDERSCORE

ORDINANCE NUMBER O-_____ (NEW SERIES)

DATE OF FINAL PASSAGE _____

AN ORDINANCE AMENDING THE SAN DIEGO MUNICIPAL CODE BY AMENDING CHAPTER 11, ARTICLE 3, DIVISION 1, BY AMENDING SECTION 113.0103; BY AMENDING CHAPTER 11, ARTICLE 3, DIVISION 2, BY REPEALING SECTION 113.0231, AND BY AMENDING SECTIONS 113.0234, 113.0237, 113.0240, 113.0243, 113.0246, 113.0249, 113.0252, 113.0261, 113.0270, AND 113.0276; BY AMENDING CHAPTER 13, ARTICLE 1 BY AMENDING DIVISION 2, SECTION 131.0215; BY AMENDING CHAPTER 13, ARTICLE 1, DIVISION 3, SECTIONS 131.0315, 131.0331, AND 131.0343, BY AMENDING CHAPTER 13, ARTICLE 1, DIVISION 4, SECTIONS 131.0415, 131.0431, 131.0443, 131.0444, 131.0448, 131.0449, 131.0453, 131.0455, AND 131.0461; AND BY REPEALING SECTION 131.0465; BY AMENDING CHAPTER 13, ARTICLE 1, DIVISION 5, BY AMENDING SECTION 131.0515; BY AMENDING CHAPTER 13, ARTICLE 1, DIVISION 6, SECTION 131.0615; AND BY AMENDING CHAPTER 14, ARTICLE 3, DIVISION 4, BY AMENDING SECTION 143.0410, ALL RELATING TO THE LAND DEVELOPMENT CODE.

§113.0103 Definitions

Abutting property through Floor [No change.]

Floor Area Ratio (FAR) means the numerical value obtained by dividing the *gross floor area* of all buildings on a *premises* by the total area of the *premises* on which the buildings are located. [See Section 113.0234 for additional information on calculating gross floor area.](#)

Freeway through Property line [No change.]

~~Proposed *grade*~~Grade means the grade of a *premises* that will result after all *development* has been completed. ~~See Section 113.0231 for additional information on determining proposed grade.~~

Proposition A Lands through Street wall line [No change.]

Street yard means the area of a *lot* or *premises* that lies between the edge of the nearest ~~*public right of way*~~street and the *street wall line*.

Structural envelope through Underfloor [No change.]

~~*Underground parking structure* means a parking structure constructed so that no more than 2 feet, 6 inches of the height of the uppermost *story* or roof is above grade.~~

Urbanized Communities through Yard [No change.]

§113.0231 Determining Proposed Grade

~~*Proposed grade* is the ground elevation that will exist when all proposed *development* has been completed. *Proposed grade* does not include pools and does not include *basements* where, at any point adjacent to the *basement*, the vertical distance between *existing grade* or *proposed grade*, whichever is lower, and the finish *floor* elevation immediately above is 2 feet, 6 inches or less, as shown in Diagram 113-02H. If a *basement* contains multiple *floors*, the finish *floor* elevation of the highest *basement floor* shall be used to determine *proposed grade*.~~

Diagram 113-02H

§113.0234 Calculating Gross Floor Area

Gross floor area is calculated in relationship to the *structure* and *grade* adjacent to the exterior walls of a building. The elements included in the *gross floor area* calculation differ according to the type of *development* proposed and are listed in Section 113.0234(a). ~~The additional elements included for development in residential zones and for residential development in other zones are listed in Section 113.0234(b). The additional elements included for commercial and industrial zones for other than residential development are listed in Section 113.0234(e).~~ (c). *Gross floor area* does not include the elements listed in Section 113.0234(d). The total gross floor area for a premises is regulated by the floor area ratio development standard.

(a) Elements Included in *Gross Floor Area* For Development in All Zones

(1) [No change.]

(2) *Gross floor area* ~~includes~~ for basements is calculated as follows:

(A) For *lots* that slope less than 5 percent along each edge of the building footprint, *gross floor area* includes the area of all portions of a *basement* where the vertical distance between *existing grade* or *proposed grade*, whichever is lower, and the finish-*floor* elevation above exceeds 3 feet, 6 inches as shown in Diagram 113-02I.

Diagram 113-02I [No Change]
Basements with Less than 5 Percent Slope

(B) [No change.]

Diagram 113-02J [No Change]
Basements with 5 Percent or More Slope

~~(3) — *Gross floor area includes those portions of underground parking structures where, at any point, the vertical distance from existing grade or proposed grade, whichever is lower, to the finish floor elevation immediately above, is more than 3 feet, 6 inches as shown in Diagram 113-02K. For the purpose of determining gross floor area of underground parking structures, proposed grade does not include openings to underground parking if there are no more than two on-grade openings for vehicular access per premises, and no more than one opening for every 50 feet of street frontage provided that the openings do not exceed a width of 16 feet for single unit residential zones, 18 feet for multiple unit residential zones, 20 feet for commercial zones, and 25 feet for industrial zones.*~~

(3) *Gross floor area for underground parking structures and subterranean garages shall be measured in accordance with Section 113.0234(a)(2), except that the vertical measurement between grade and the finished floor above shall not include subterranean vehicular access openings (up to a maximum of 25 foot width). In*

order to determine which portion of the underground parking structure counts as gross floor area, the vertical distance to the finished floor above shall be measured from the imaginary plane perpendicular to the driveway access that connects the adjacent grades on each side as shown in Diagram 113-02K. Where vehicular access openings are greater than 25 feet in width (as measured at the point of entry to the structure), the entire floor shall be counted as gross floor area.

Diagram 113-02K
Underground Parking Structures

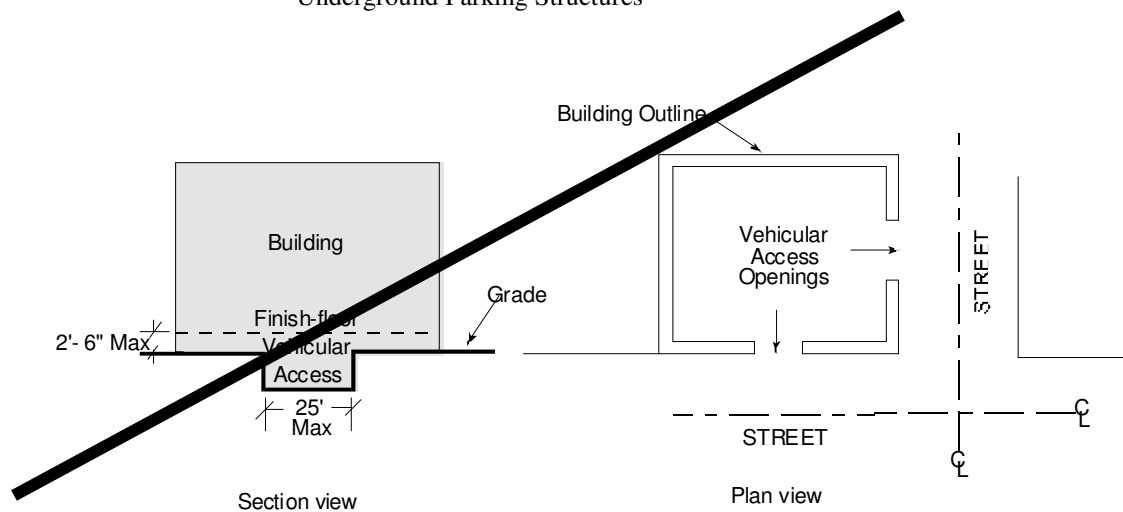
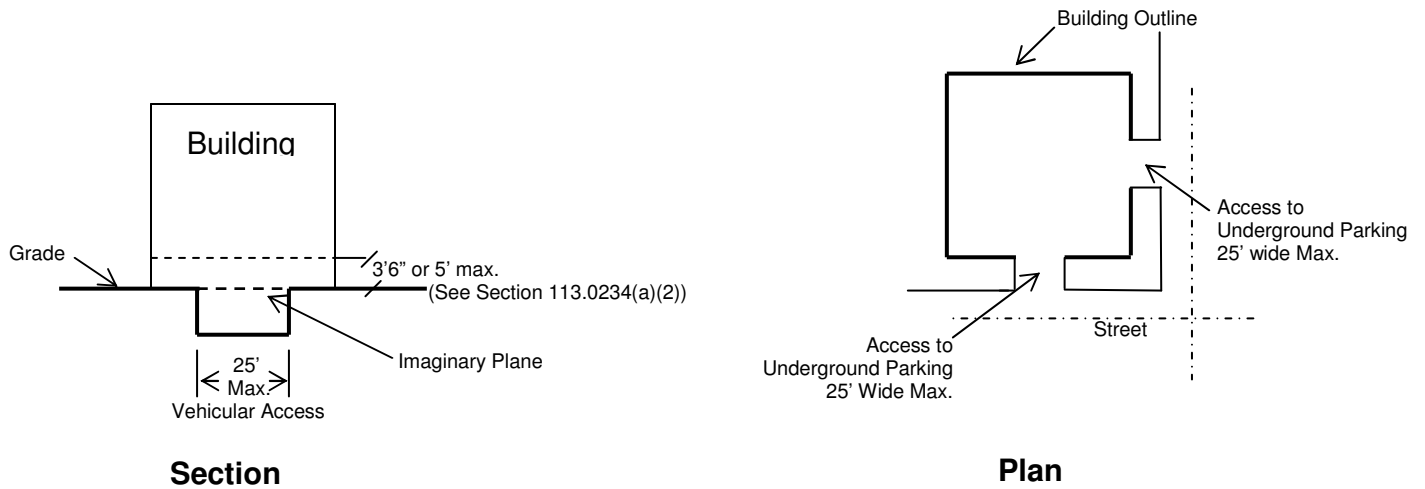

Diagram 113-02K
Underground Parking Structures



(4) through (7) [No change.]

Diagrams 113-02L and 113-02M [No change.]

(b) Additional Elements Included in *Gross Floor Area* in Residential Zones and for Residential Development in Other Zones.

(1) and (2) [No change.]

Diagrams 113-02N and 113-02O [No change.]

(3) *Gross floor area* includes any at-grade space that is built with enclosed space above, when there is at least 7-foot 6-inches between grade and the finish-floor elevation above, and the enclosed space above projects at least 4 feet from the face of the structure and exceeds a height of 5 feet measured from the top of

the wall or post supporting the space to the top of the roof above ~~when, as shown in Diagram 113-02P. Where~~ the gradient along any edge of the at-grade space is ~~less than 5 percent, as shown in Diagram 113-02P. Gross floor area in this situation includes the area of the~~ greater than 25 percent, the unenclosed at-grade space ~~when there is at least 7' 6" between grade and the finish floor elevation of the space above and that portion of the area of the enclosed space above that exceeds the 5-foot height.~~ shall not be counted as gross floor area.

Diagram 113-02P
Carport with Enclosed Space Above

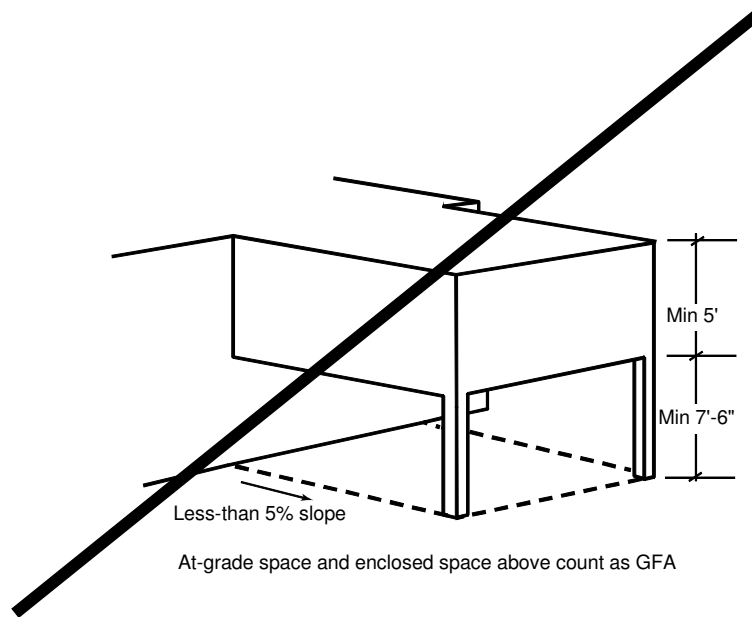
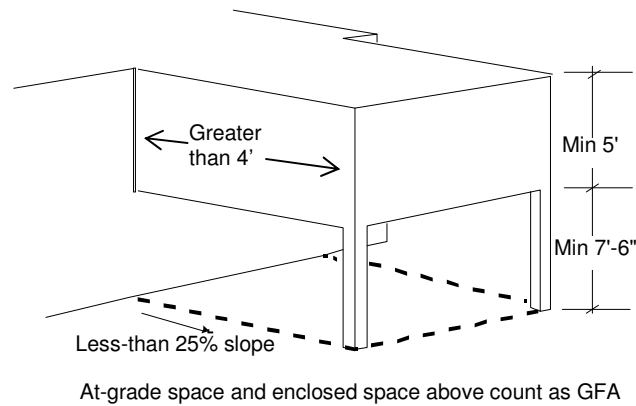

Diagram 113-02P
At-Grade Space with Enclosed Space Above



(4) [No change.]

(A) *Phantom Floors*. When the vertical distance between the finish-*floor* elevation and the finish-*floor* or flat roof immediately above does not exceed 15 feet, the area of one *floor* (the actual *floor*) is included in *gross floor area*, as shown in Diagram 113-02Q.

Diagram 113-02Q [No change.]

When the vertical distance between the finish-*floor* elevation and the elevation at the midpoint of the sloped roof immediately above that has at least a 2:12 pitch (2 vertical feet to 12 horizontal feet) pitch does not exceed 15 feet, and the elevation of the highest point of the roof does

not exceed 20 feet, the area of one floor (the actual floor) is included in gross floor area, regardless of the location of the ceiling, as shown in Diagram 113-02R.

Diagram 113-02R
One Floor Below Sloped Roof

When the vertical distance between the finish floor elevation and the finish-floor or flat roof elevation immediately above exceeds 15 feet, gross floor area includes the area of the actual floor plus the area of a phantom floor at 15 feet of height and at each 7-foot, 6-inch increment increments, or portion thereof, of height above the 15-foot height, as shown in Diagram 113-02SR.

Diagram 113-02S
Multiple Floors Below Actual Floor and Flat Roof

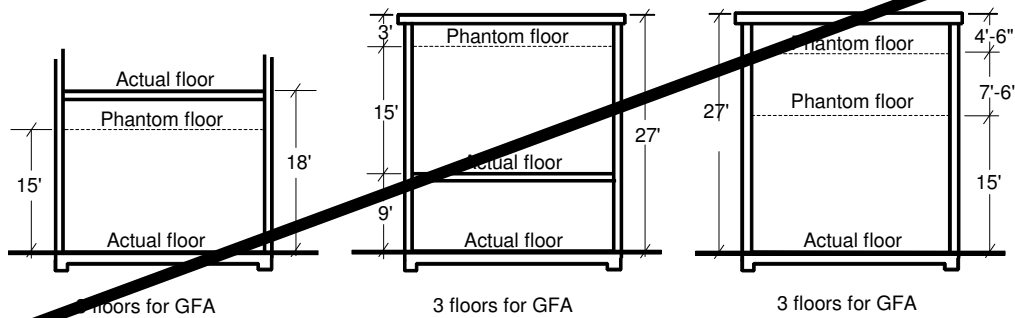
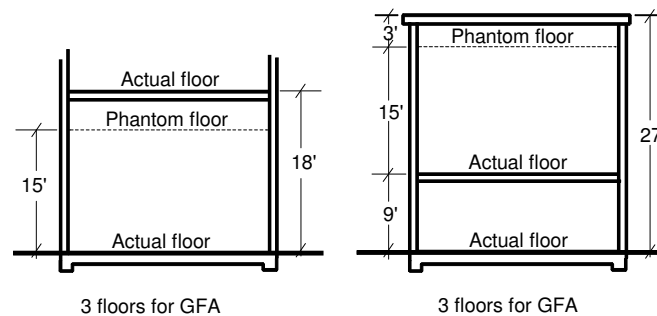

Diagram 113-02R
Multiple Floors below Actual Floor and Flat Roof



~~When the vertical distance between the finish floor elevation and the elevation at the midpoint of the sloped roof immediately above that has at least a 2:12 pitch (2 vertical feet to 12 horizontal feet) exceeds 15 feet or the elevation of the highest point of the roof immediately above exceeds 20 feet, gross floor area includes the area of the actual floor plus the area of a phantom floor at 15 feet of height and at each 7-foot, 6-inch increment of height above the 15-foot height, regardless of the location of the ceiling, as shown in Diagram 113-02T. Gross floor area excludes those portions of actual floors and phantom floors where there is less than 5 feet, 6 inches of vertical distance between the actual or phantom floor and the elevation of the roof immediately above.~~

Diagram 113-02T
Multiple Floors Below Sloped Roof

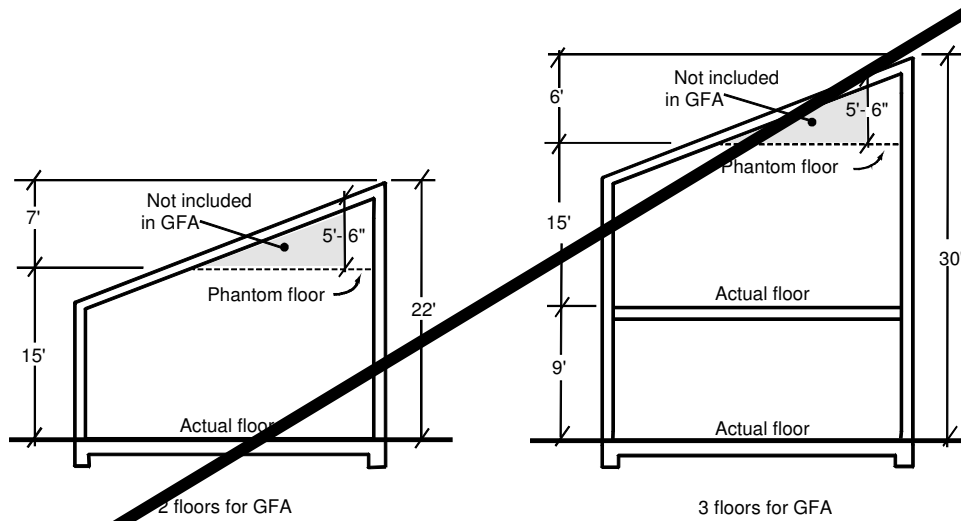
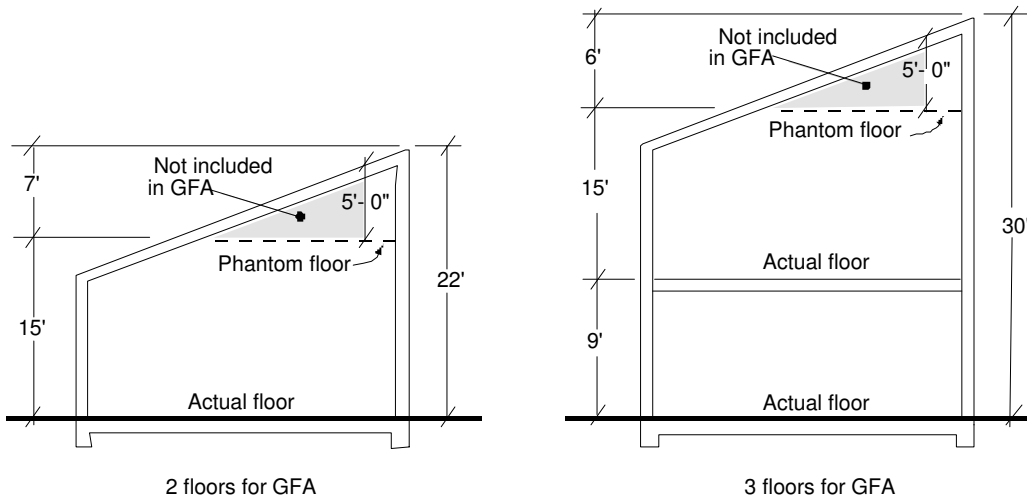

Diagram 113-02S
Multiple Floors Below Sloped Roof



(B) Attic Space. Gross floor area includes the attic space
above ceilings according to the regulations for phantom

~~floors in Section 113.0234(b)(4)(A),~~ as shown in Diagram

113-02U:T, where there are at least 5 feet of vertical
distance between the attic floor and the roof elevation

immediately above. The location of any ceilings

immediately below the roof does not affect the

measurement of phantom floors above the highest finish-

floor elevation.

Diagram 113-02U
Attic Space

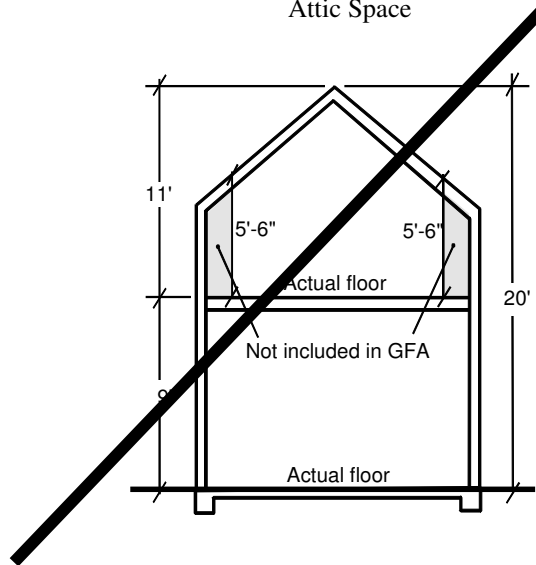
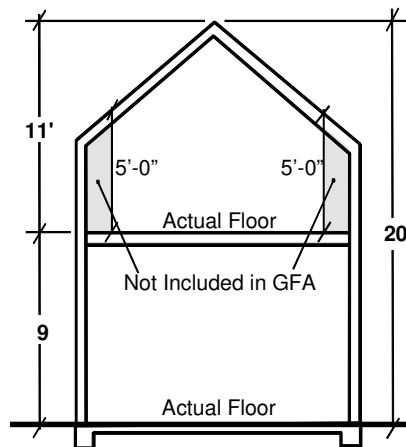

Diagram 113-02T
Attic Space



- (C) Underfloor Area. ~~For sloping lots with a minimum slope of 5 percent within the building footprint, gross~~ Gross floor area includes additional phantom floors within the enclosed space below the lowest finish-floor elevation. In this case, the area of a phantom floor is included in gross floor area at each ~~8-15-foot, 6-inch~~ 8-15-foot increment, or portion thereof, of height between the lowest finish-floor elevation and grade, measured vertically from the lowest finish-floor elevation, as shown in Diagram 113-02VU. Gross floor area excludes any area where there is less than 5 feet of height between grade and the finish-floor or phantom floor elevation immediately above.

Diagram 113-02V
Underfloor Area

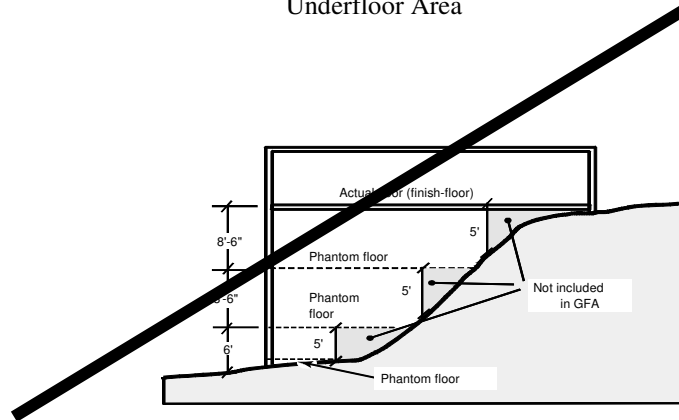
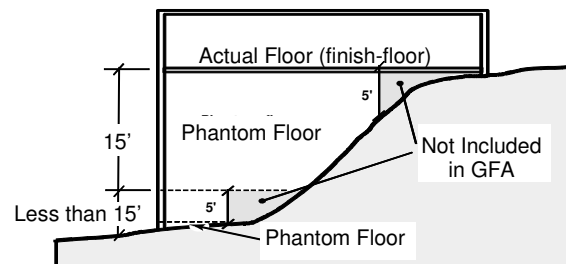

Diagram 113-02U
Underfloor Area



- (D) Interior Balconies, Mezzanines, and Lofts. *Gross floor area* includes the area within a building adjacent to all interior balconies, mezzanines, and lofts, pursuant to the regulations for phantom floors in Section 113.0234(b)(4)(A) as if such elements did not exist adjacent to the space, as shown in Diagram 113-02WV. The location of an adjacent interior balcony, mezzanine, or

loft does not affect the location of phantom floors above the finish-floor elevation of the adjacent space.

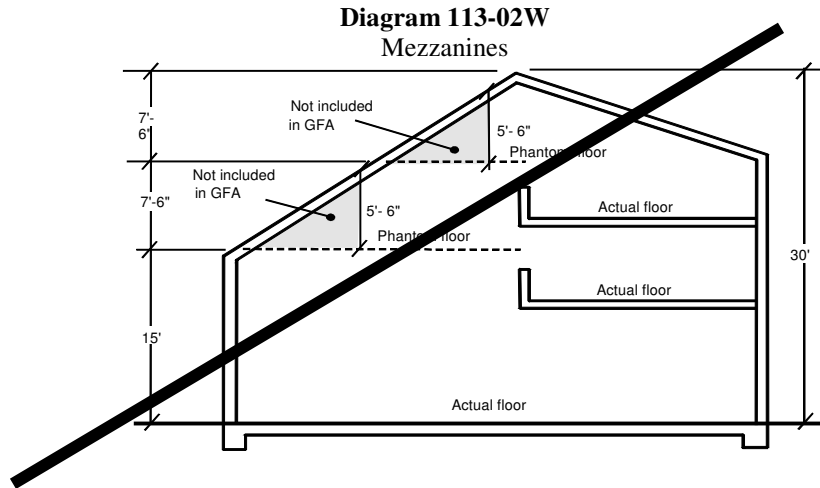
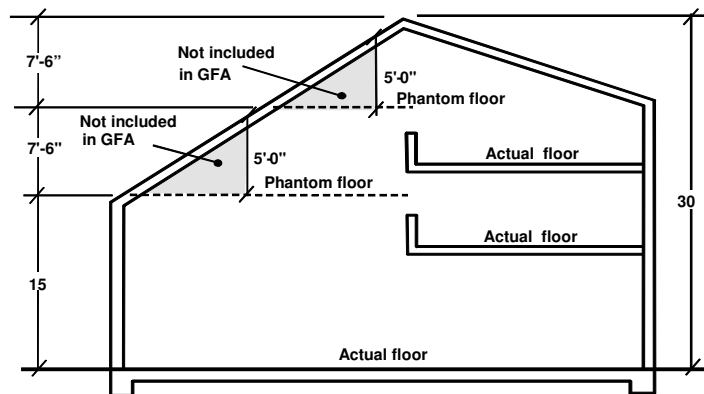

Diagram 113-02V
Mezzanines



- (E) *Atriums.* Gross floor area includes the area of the horizontal projection into the *atrium* from each adjacent floor in plan view. If no adjacent floors ~~exist~~exist, the regulations for phantom floors in Section

113.0234(b)(4)(A) apply to the space within the *atrium*.

This is illustrated in Diagram 113-02~~X~~W.

Diagram 113-02~~X~~W

~~(5)~~(5) [No change.]

(c) and (d) [No change.]

§113.0237 Determining a Lot

(a) A *lot* is legal for purposes of *development* if it meets any one of the following criteria:

~~(1)~~(1) The *lot* is an individual parcel designated with a number or letter on a ~~subdivision~~final map or *parcel map* recorded with the County Recorder, a record of survey map approved by resolution of the City Council and recorded with the County Recorder after December 5, 1954, or a division plat approved by and filed with the Development Services Department; or

~~(2)~~(2) The *lot* has been officially determined as a suitable building site or ~~a site for another particular use by a variance, certificate of compliance, or other~~approved for development under the Land Development Code ~~procedure~~; or

~~(3)~~ (3) The *lot* was ~~held as a separate parcel~~ created before March 4, 1972
as a result of a boundary adjustment between two adjoining *lot*
owners wherein the land was taken from one parcel and added to
the adjoining parcel and no new *lots* were thereby created; or

(4) The *lot* was created before March 4, 1972, held as a separate parcel
by a subsequent purchaser, and has at least 15 feet of street
frontage or other legal access to a dedicated street as approved by
the City Engineer; or

~~(4)~~ (5) The *lot* was held as a separate legal parcel upon annexation to the
City of San Diego.

~~(b)~~ ~~[No change.]~~ (b) [No change to text.]

(c) A Certificate of Compliance may be requested in accordance with Section
125.0210 to certify that a *lot* is legal for *development*.

§113.0240 Calculating Lot Coverage

Lot coverage is calculated by dividing the square footage of the *structure's*
footprint, measured from the outer surface of the exterior walls or support
structure by the square footage of the *lot*. *Lot coverage* is expressed as a
percentage (for example, 60 percent). This is illustrated in Diagram ~~113-~~
~~02~~ 113.02.

Diagram 113-02 ~~Y~~ X

(a) through (c) [No change.]

(d) Those portions of ~~underground parking~~ underground parking structures, first stories, and basements lying 3 feet or less above grade; and

(e) [No change.]

§113.0243 Measuring Lot Depth and Lot Width

(a) through (b) [No change.]

Diagram 113-02ZY

(c) Lot Width for Residential Lots

(1) For irregularly shaped lots, such as pie shaped lots, the lot width is determined by calculating the average lot width for the first 50 feet of lot depth.

(2) For consolidated lots, the lot width is equivalent to the total width of the premises after the consolidation.

§113.0246 Determining Property Lines

[No change in first paragraph.]

(a) through (d) [No change.]

Diagram 113-02AAZ [No change in Diagram]

Diagram 113-02BBA [No change in Diagram]

Diagram 113-02 ~~CEBB~~ [No change in Diagram]

(e) Property Lines that Abut an Alley. A property line that abuts an alley shall be determined in accordance with Section 113.0237 (a) through (d).

However, the property line that abuts an alley shall not be considered a street property line for the purpose of determining setbacks or street yards as indicated below:

(1) Alley adjacent to front property line. A setback equivalent to a rear yard shall be applied when a lot abuts an alley as a front property line.

(2) Alley adjacent to side property line. A setback equivalent to an interior side yard shall be applied when a lot abuts an alley as a street side property line.

(3) Alley adjacent to rear property line. A setback equivalent to a rear yard shall be applied when a lot abuts an alley as a rear property line.

Diagram 113-02CC Alley Setbacks

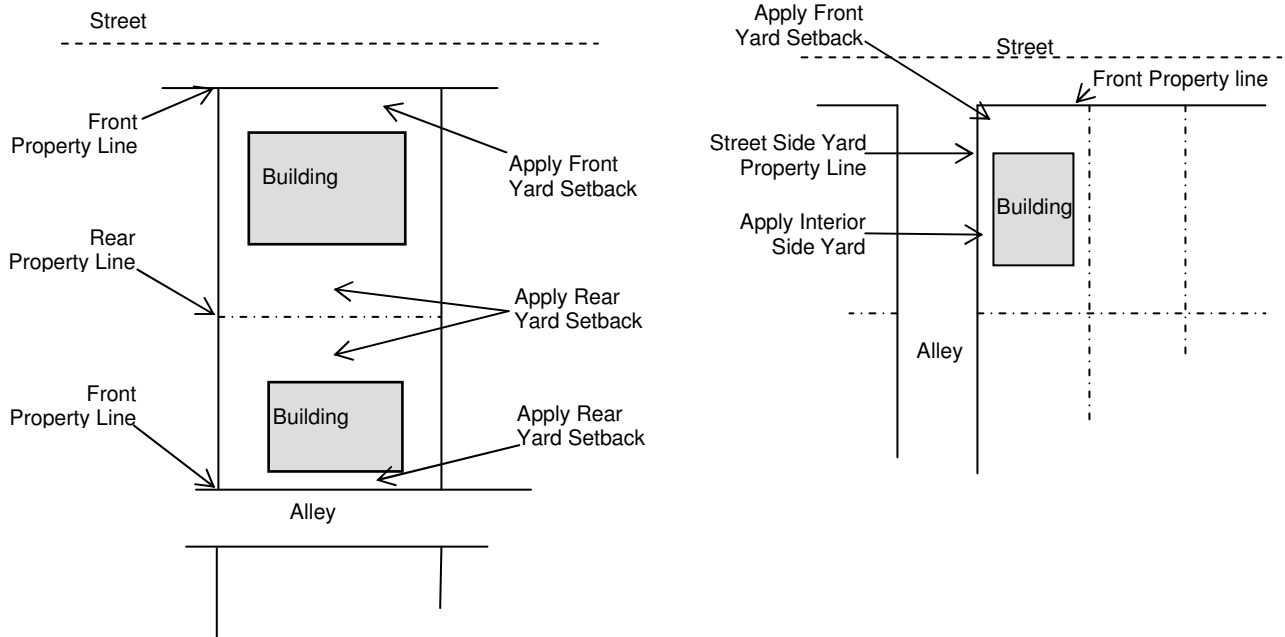

§113.0249 Determining Setback Line

(a) and (b) [No change.]

(c) Where it can be demonstrated that setback lines shown on a final map, survey or other planning document were plotted solely for information purposes to illustrate the setback dimensions that were in effect at the time the document was approved, the setback required by the underlying base zone in the Land Development Code shall apply.

(d) When a side setback is allowed to observe the minimum dimensions as described in Section ~~131.0443(a)(3)(Setback Requirements in Residential Zones)~~ 131.0431, all additions to the primary structure thereafter shall maintain that established side setback.

§113.0252 Measuring Setbacks

(a) The distance of the *setback* is measured inward from and perpendicular to the nearest *property line*, as follows, except as otherwise indicated in Section 113.0246(e):

(1) through (4) [No change.]

(b) Those portions of ~~underground parking~~ underground parking structures, first stories, and basements that are above *grade* are subject to *setback* requirements. Structures located completely underground are exempt from the *setback* requirements except where the *structure* would conflict with the required landscape and irrigation, or as otherwise regulated by Section 131.0461.

(c) For the purpose of determining whether new *development* complies with the *setback*, the measurement shall be taken from the *property line* inward to the outer edge of the building frame. Where a zero *setback* is provided, the edge of finished material shall not extend beyond the *property line*.

§113.0261 Determining a Story

[No change first paragraph.]

(a) through (c) [No change.]

(d) ~~Underground Parking~~ Underground Parking Structures and Basements.
~~Underground parking~~ Underground parking structures and basements are

stories if there is a vertical distance, at any point, of 6 feet or more between *existing grade* or *proposed grade*, whichever is lower, and the finish-floor elevation immediately above. ~~For the purpose of determining a story, proposed grade does not include openings to underground parking structures if there are no more than two on-grade openings for vehicular access per premises, and no more than one opening for every 50 feet of street frontage, provided that the openings do not exceed 16 feet for single unit residential zones, 18 feet for multiple unit residential zones, 20 feet for commercial zones, and 25 feet for industrial zones.~~ See Diagram 113-02EE.

Diagram 113-02EE
Underground Parking Structures and Basements

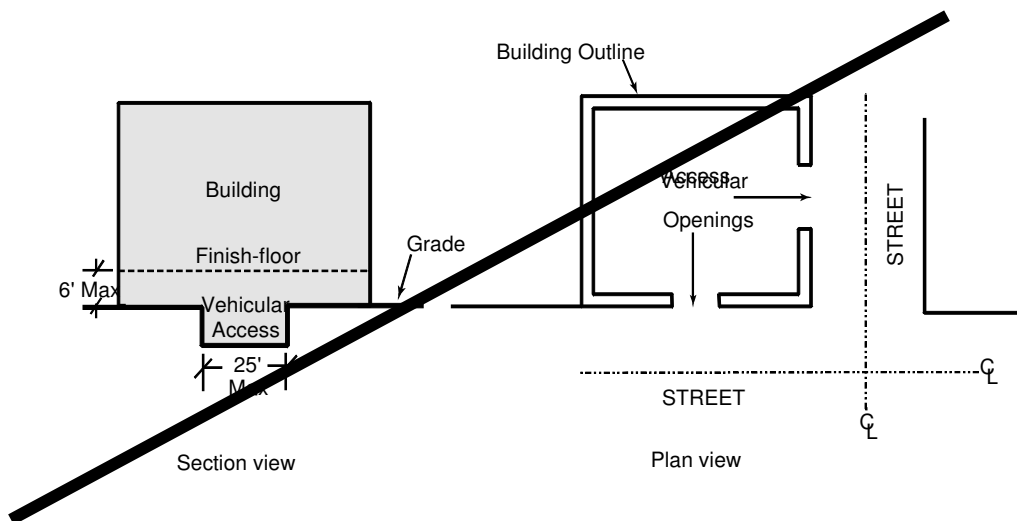
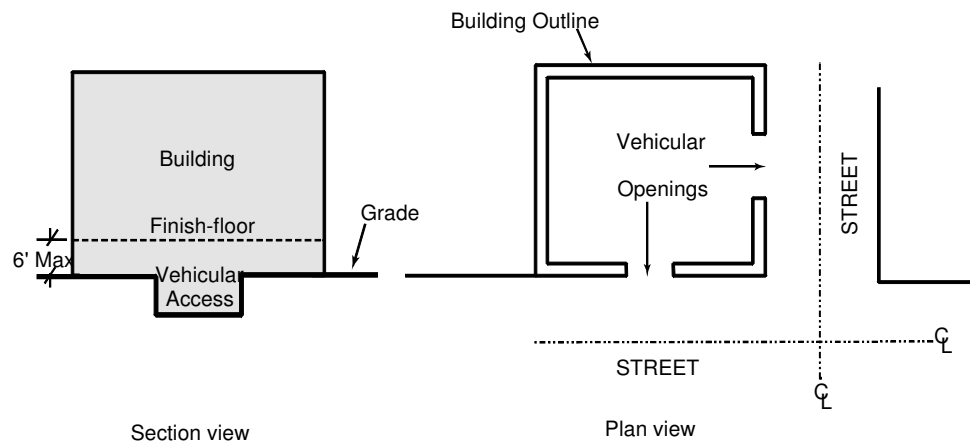

Diagram 113-02EE
Underground Parking Structures and Basements



§113.0270 Measuring Structure Height

~~Structure height is measured in accordance with the following.~~

(a) *Structure Height* of Buildings and ~~Structures Other Than~~ (Excluding Fences, Retaining Walls, or Signs)

(1) The maximum permitted *structure height* is specified in the applicable zone and defines the upper limits of the *building envelope* for a *premises*. It is measured vertically from the *existing grade* or *proposed grade*, whichever is lower, to form an imaginary plane that is parallel to *grade*, below which all buildings and *structures* must be located, except as otherwise described in 113.0270(a)(~~34~~). This is illustrated in Diagram 113-02II.

Diagram 113-02II [No change.]

~~(2) — Where there is an extreme natural topographic variation on a premises that covers 10 percent or less of the proposed structure's footprint, as shown in Diagram 113-02JJ, structure height is measured from an imaginary plane made by connecting the perimeter points of the topographic variation, so that the imaginary plane above and parallel to grade will not reflect the extreme natural topographic variation.~~

~~Diagram 113-02JJ~~ [No change.]
Extreme Topographic Variation

(2) A two part calculation is required to measure structure height including:

~~(3)~~ A) Plumb line measurement. The structure height is measured from all points on top of a structure to existing grade or proposed grade, whichever is lower, directly below each point, except as described in Section 113.0270(a)(4). This measurement is taken vertically through the structure at each point where structure height is being measured, as shown in Diagram 113-2~~KK~~, ~~except as described in Section 113.0270(a)(4)JJ.~~

Diagram 113-02~~KK~~JJ [No change.]
Measurement of Structure Height

~~(4) — Where a basement, underground parking structure, interior court, or other similar interior area is proposed, the lower of existing grade or proposed grade, adjacent to and within 5 feet of that portion of the structure shall be used to measure structure height, as shown in Diagram 113-02LL. Structure height for this purpose shall be measured from an imaginary plane through the building that connects these grade elevations on both sides of the structure.~~

Diagram 113-02LL
Structure Height at Basement

~~(5) B) Overall Height Measurement.~~ The overall *structure height* is measured from the lowest point of *existing grade* or *proposed grade* within 5 feet of the structure's perimeter (building wall, balcony, bay window, or similar *architectural projection*) or at the *property line*, whichever is closer, to the highest point of the *structure*, projected horizontally to directly above this lowest point of *grade*; ~~except as specified in Section 113.0270(a)(6).~~ The overall *structure height* shall not exceed the maximum permitted *structure height* of the applicable zone plus an amount equal to either the maximum *grade* differential within the structure's footprint or 10 feet, whichever is less. In no case may the *structure height* exceed the maximum

allowed by the applicable zone at any one point ~~measured~~
~~pursuant to Section 113.0270(a)(3)~~. This is illustrated in
Diagram 113-02MMKK.

Diagram 113-02MM
Overall Structure Height

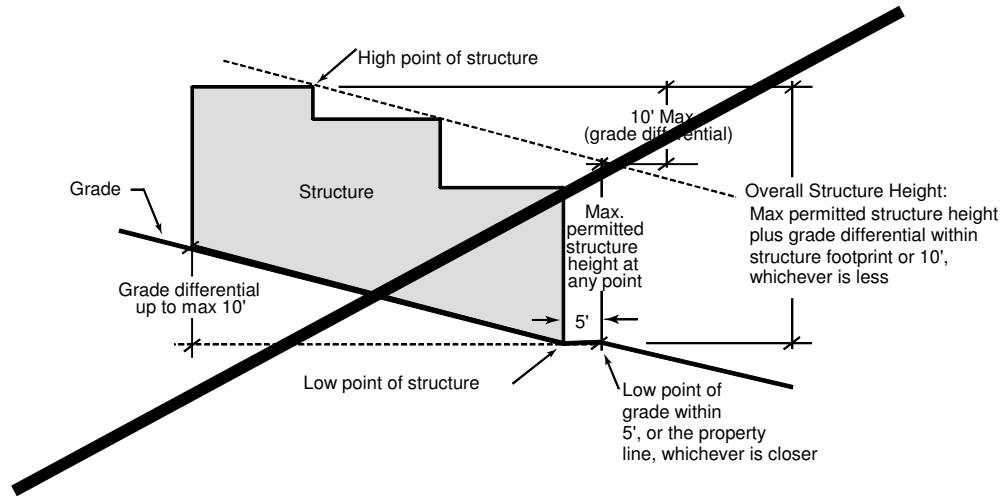
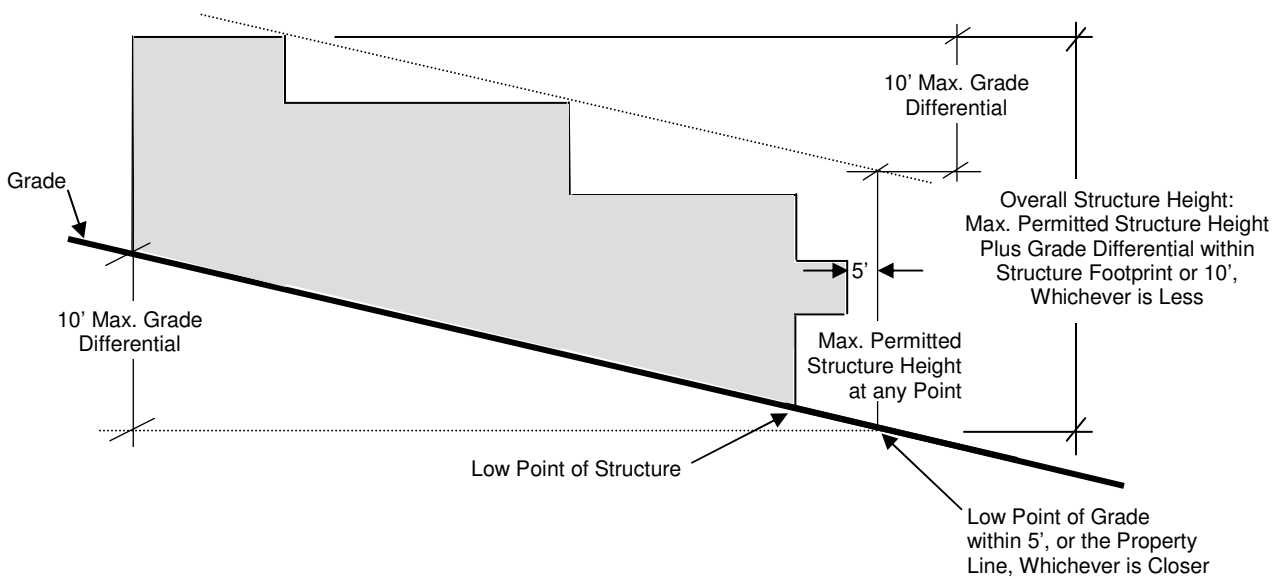

Diagram 113-02KK
Overall Structure Height



(3) Structure height is measured separately for each structure that is separated from another structure on the premises by 6 feet or more. Separation between structures shall be measured in plan view to account for the structural envelope of each structure.

(4) Special Circumstances

(A) Extreme Topographic Variation. Where there is an extreme natural topographic variation on a premises that covers 10 percent or less of the proposed structure's footprint, as shown in Diagram 113-02LL, overall structure height is measured from an imaginary plane made by connecting the perimeter points of the topographic variation, so that the imaginary plane above and parallel to grade will not reflect the extreme natural topographic variation.

Diagram 113-02LL
Extreme Topographic Variation

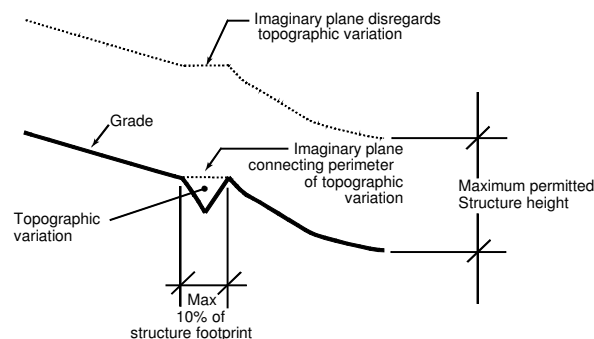

(B) Measuring Structure Height for Subterranean Areas

- (i) Interior Subterranean Areas. Where a basement, underground parking structure, interior court, or other similar interior subterranean area is proposed, the plumb line measurement to the lower of existing grade or proposed grade shall be measured to an imaginary plane through the building that connects the adjacent grade elevations on both sides of the structure as shown in Diagram 113-02MM.

**Diagram 113-02MM
Imaginary Plane and Plumb Line**

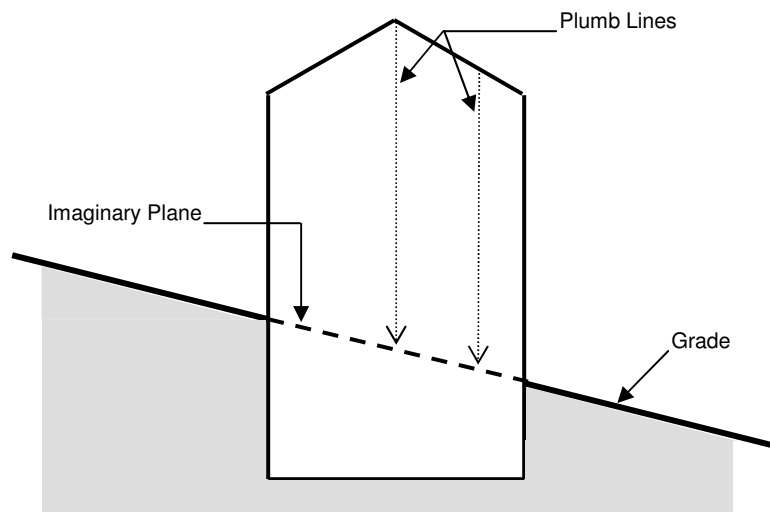

- ~~(6) For the purpose of measuring~~ (ii) Exterior Subterranean Areas. The overall structure height on a structure that provides pedestrian access or

~~ventilation to a basement where the vertical distance between the adjacent grade and the finish *floor* elevation above does not exceed 2 feet, 6 inches, the lowest point of *existing grade* or *proposed grade* within 5 feet of the structure's perimeter does not include one pedestrian or ventilation access with dimensions of up to 5 feet by 15 feet which abuts the *structure*~~measurement shall not include subterranean vehicular access, exterior subterranean pedestrian access or ventilation to a *basement*.
Overall *structure* height shall instead be measured from an imaginary plane connecting to the lowest adjacent *grade* immediately above the exterior *subterranean space*, as shown in Diagram 113-02NN.

Diagram 113-02NN
Access to Basement

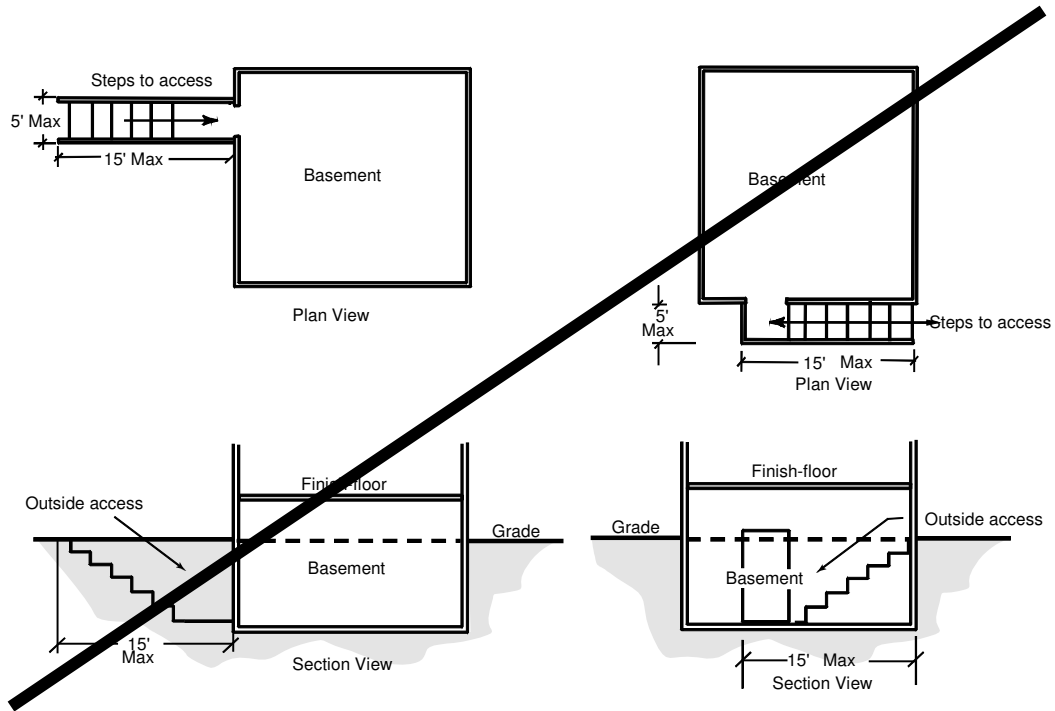
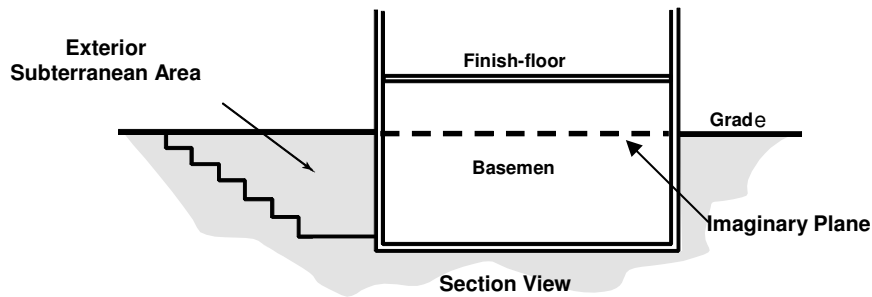

Diagram 113-02NN
Access and Ventilation to Basement



~~(7) — Structure height is measured separately for each structure that is separated from another structure on the premises by~~

~~6 feet or more.~~(8C) When a pool is located within 5 feet of the *structure*, the overall *structure height* ~~is measured as noted in Section 113.0270(a)(5), except that proposed grade~~ shall not include the pool. This is illustrated in Diagram 113.0200.

Diagram 113-0200 [No change-]
Overall Structure Height with Pool

(D) Structure Height of Buildings subject to Coastal Height Limit in accordance with Section 132.0505

- (i) The height of a building is measured to the uppermost point of the structure or any appurtenance placed upon the roof thereof, including signs, penthouses, mechanical equipment, chimneys, vent stacks, spires, or steeples, or other projections.
- (ii) The base of the measurement shall be taken from finished grade in accordance with the 1970 Uniform Building Code. The height shall be measured from the highest adjoining sidewalk or ground surface within 5 feet of the structure, provided that the height measured from the lowest adjoining surface

shall not exceed such maximum height by more
than 10 feet.

(b) and (c) [No change.]

Diagrams 113-02PP and 113-02QQ [No change.]

§113.0276 Determining Yards

~~(a)~~ [No change to text.]

[No change to Diagram 113-02SS.]

~~(b) — Those portions of *underground parking structures, first stories, and basements* lying more than 3 feet above *grade* are subject to all yard requirements.~~

~~(c) — Those portions of *underground parking structures, first stories, and basements* lying between 0 and 3 feet above *grade* are subject to front yard and street side yard requirements in those zones that require landscaping in the front and street side yards.~~

§131.0215 Where Open Space Zones Apply

On the effective date of Ordinance O-18691, all open space zones that were established in Municipal Code Chapter 10, Article 1, Division 4 ~~shall be~~ were amended and replaced with the base zones established in this division, ~~as shown in Table 131-02A.~~

Table 131-02A
Open Space Zone Applicability

Previous Chapter 10 Open Space Zone Replaced with New Open Space Zone Established by this Division	
Open Space Zone that Existed on December 31, 1999.	Applicable Zone of this Division
OS-OSP	OP-2-1
OS-P, OS-R	OP-1-1
FC, FW	OF-1-1
OS-TDR	None
No Existing Zone	OC-1-1
No Existing Zone	OR-1-1
No Existing Zone	OR-1-2

§131.0315 Where Agricultural Zones Apply

On the effective date of Ordinance O-18691, all agricultural zones that were established in Municipal Code Chapter 10, Article 1, Division 4 ~~shall be~~ were amended and replaced with the base zones established in this division, ~~as shown~~ in Table 131-03A.

Table 131-03A
Agricultural Zone Applicability

Previous Chapter 10 Agricultural Zone Replaced With New Agricultural Zone Established by This Division	
Agricultural Zone that Existed on December 31, 1999.	Applicable Zone of this Division
A-1-1	AR-1-2
A-1-5, A-1-10	AR-1-1
A-1-20	None
A-1-40	None
No Existing Zone	AG-1-1
No Existing Zone	AG-1-2

§131.0331 Development Regulations Table for Agricultural Zones

The following development regulations apply in the agricultural zones as shown in Table 131-03C.

**Table 131-03C
Development Regulations of Agricultural Zones**

Development Regulations [See Section 131.0330 for Development Regulations of Agricultural Zones]	Zone Designator	Zones			
	1st & 2nd >>	AG		AR	
	3rd >>	1-	1-	1-	1-
	4th >>	1	2	1	2
Max Permitted Residential Density (DU Per Lot)		1 ⁽¹⁾	1 ⁽¹⁾	1 ⁽²⁾	1 ⁽³⁾
Min Lot Area (ac)		10	5	10	1
Min Lot Dimensions					
Lot Width (ft)		200	200	200	100 ⁽⁴⁾
Street Frontage (ft)		200	200	200	100 ⁽⁵⁾
Lot Depth (ft)		200	200	200	150
Setback Requirements [See Section 131.0343]					
Min Front Setback (ft)		25	25	25	25
Min Side Setback(ft)		20	20	20	20
Min Rear Setback (ft)		25	25	25	25
Max Structure Height (ft) [See Section 131.0344]		30	30	30	30
Max Lot Coverage (%) ⁽⁷⁾		10	20	10	20
Min Floor Area ⁽⁶⁾		applies	applies	applies	applies

Footnotes for Table 131-03C
1-7 [No change]

§131.0343 Setback Requirements in Agricultural Zones

(a) The minimum side *setback* for a legal *lot* that existed on the effective date of this section and that has less than the minimum lot width specified in Table 131-03C, is 10 percent of the width of the *lot* or 5 feet, whichever is greater.

(b) Architectural projections and encroachments may be permitted in accordance with the regulations in Section 131.0461 for lots in Agricultural-Residential (AR) zones that are one acre or less in lot area.

§131.0415 Where Residential Zones Apply

On the effective date of Ordinance O-18691, all residential zones that were established in Municipal Code Chapter 10, Article 1, Division 4 ~~shall be~~ were amended and replaced with the base zones established in this division, ~~as shown in Table 131-04A.~~

**Table 131-04A
Residential Zone Applicability**

Previous Chapter 10 Residential Zone Replaced With New Residential Zone Established by This Division	
Residential Zone That Existed on December 31 1999.	Applicable Zone of This Division
No Existing Zone	RE-1-1
No Existing Zone	RE-1-2
No Existing Zone	RE-1-3
R1-40,000 in Urbanized Communities as of December 31 1999.	RS-1-1
R1-20,000 in Urbanized Communities as of December 31 1999.	RS-1-2
R1-15,000 in Urbanized Communities as of December 31 1999.	RS-1-3
R1-10,000 in Urbanized Communities as of December 31 1999.	RS-1-4
R1-8,000 in Urbanized Communities as of December 31 1999.	RS-1-5
R1-6,000 in Urbanized Communities as of December 31 1999.	RS-1-6
R1-5,000 in Urbanized Communities as of December 31 1999.	RS-1-7
R1-40,000 in Planned Urbanizing Communities and Future Urbanizing Area as of December 31 1999.	RS-1-8
R1-20,000 in Planned Urbanizing Communities and Future Urbanizing Area as of December 31 1999.	RS-1-9
R1-15,000 in Planned Urbanizing Communities and Future Urbanizing Area as of December 31 1999.	RS-1-10
R1-10,000 in Planned Urbanizing Communities and Future Urbanizing Area as of December 31 1999.	RS-1-11
R1-8,000 in Planned Urbanizing Communities and Future Urbanizing Area as of December 31 1999.	RS-1-12
R1-6,000 in Planned Urbanizing Communities and Future Urbanizing Area as of December 31 1999.	RS-1-13
R1-5,000 in Planned Urbanizing Communities and Future	RS-1-14

Previous Chapter 10 Residential Zone Replaced With New Residential Zone Established by This Division	
Residential Zone That Existed on December 31 1999.	Applicable Zone of This Division
Urbanizing Area as of December 31 1999.	
No Existing Zone	RX-1-1
R-1-5,000/SLO	RX-1-2
No Existing Zone	RT-1-1
No Existing Zone	RT-1-2
No Existing Zone	RT-1-3
No Existing Zone	RT-1-4
R-3000	RM-1-1
R-2500	RM-1-2
R-2000	RM-1-3
R-1750	RM-2-4
R-1500	RM-2-5
R-1250	RM-2-6
R-1000	RM-3-7
R-800	RM-3-8
R-600	RM-3-9
R-400	RM-4-10
R-200	RM-4-11
RV	RM-5-12

§131.0431 Development Regulations Table of Residential Zones

~~The following development regulations apply in the residential zones as shown in the Table 131-04C, 131-04D, 131-04E, and 131-04F.~~

~~[No change first paragraph.]~~

- (a) RE Zones

Table 131-04C
Development Regulations of RE Zones

Development Regulations [See Section 131.0430 for Development Regulations of Residential Zones]	Zone designator		Zones			
	1st & 2nd >>	RE-				
	3rd >>	1-	1-	1-		
	4th >>	1	2	3		
Max permitted density (DU per lot) through Supplemental requirements [See Section 131.0464(a)]		[No change.]				
Diagonal plan dimension		-	-	-		

(b) RS Zones

Table 131-04D
Development Regulations of RS Zones

Development Regulations [See Section 131.0430 for Development Regulations of Residential Zones]	Zone Designator		Zones					
	1st & 2nd >>	RS-						
	3rd >>	1-	1-	1-	1-	1-	1-	1-
	4th >>	1	2	3	4	5	6	7
Max permitted density (DU per lot) through Min Lot dimensions [No Change]								
Setback requirements								
Min Front setback (ft) [See Section 131.0443(a)(1)]		25 ⁽¹⁾	25 ⁽¹⁾	20 ⁽¹⁾	20 ⁽¹⁾	20 ⁽¹⁾	15 ⁽¹⁾	15 ⁽¹⁾
Min Side setback (ft) [Multiply number in table by actual lot width to calculate setback]		10.08 ⁽²⁾	10.08 ⁽²⁾	6.08 ⁽²⁾	6.08 ⁽²⁾	6.08 ⁽²⁾	5.08 ⁽²⁾	4.08 ⁽²⁾
Min Street side setback (ft) [Multiply number in table by actual lot width to calculate setback]		10 ⁽²⁾	10 ⁽²⁾	10 ⁽²⁾	10 ⁽²⁾	10 ⁽²⁾	10 ⁽²⁾	10 ⁽²⁾
Min Rear setback (ft)		25 ⁽³⁾	25 ⁽³⁾	20 ⁽³⁾	20 ⁽³⁾	20 ⁽³⁾	15 ⁽³⁾	13 ⁽³⁾
Setback requirements for resubdivided corner lots [See Section 131.0443(i)] through Supplemental requirements [No Change]								
Diagonal plan dimension [See Section 131.0465]		-	-	-	-	-	-	applies
Bedroom regulation [No Change]								

Development Regulations [See Section 131.0430 for Development Regulations of Residential Zones]	Zone Designator		Zones					
	1st & 2nd >>	RS-						
	3rd >>	1-	1-	1-	1-	1-	1-	1-
	4th >>	8	9	10	11	12	13	14
Max permitted density (DU per lot) through Min Lot dimensions [No Change]								
Setback requirements								

Development Regulations [See Section 131.0430 for Development Regulations of Residential Zones]	Zone Designator		Zones						
	1st & 2nd >>		RS-						
	3rd >>		1-	1-	1-	1-	1-	1-	
	4th >>		8	9	10	11	12	13	14
Min Front setback (ft) [See Section 131.0443(a)(1)]			25 ⁽¹⁾	25 ⁽¹⁾	25 ⁽¹⁾	20 ⁽¹⁾	15 ⁽¹⁾	15 ⁽¹⁾	15 ⁽¹⁾
Min Side setback (ft)			10	8	7	6	5	5	4
Min Street side setback (ft)			20	15	15	10	10	10	10
Min Rear setback (ft)			10 ⁽⁶⁾	10 ⁽⁶⁾	10 ⁽⁶⁾	10 ⁽⁶⁾	10 ⁽⁶⁾	10 ⁽⁶⁾	10 ⁽⁶⁾
Setback requirements for resubdivided corner lots [See Section 131.0443(i)] through Supplemental requirements [No Change]									
Diagonal plan dimension [See Section 131.0465]			-	-	-	-	-	-	-
Bedroom regulation [No Change]									

Footnotes for Table 131-04D

- 1 For lots where at least one-half of the front 50 feet of the lot depth has a minimum slope gradient of 25 percent, the setback closest to the street frontage may be reduced to a minimum 6 feet.
- 2 The required side setbacks may be reallocated where the combined dimension of each side setback would meet or exceed the combined total required in Table 131-04D. In no case shall a side setback be reduced to less than 4 feet. Once a side setback is established, all additions to the primary structure thereafter shall maintain the established side setback.
- 3 See Section 131.0443(a)(2).
- ~~2 See Section 131.0443(a)(3).~~
- ~~3 See Section 131.0443(a)(4).~~
- 4 See Section 131.0444(b).
- 5 See Section 131.0446(a).
- 6 See Section 131.0443(a)(~~5~~3).
- 7 On lots less than 10,000 square feet a single dwelling unit shall be limited to 6 bedrooms maximum.

(c) RX Zones

Table 131-04E
Development Regulations of RX Zones

Development Regulations [See Section 131.0430 for Development Regulations of Residential Zones]	Zone designator	Zones	
	1st & 2nd >>	RX-	
	3rd >>	1-	1-
	4th >>	1	2
Maximum permitted <i>density</i> (DU per <i>lot</i>) through Supplemental regulations [See Section 131.0464(b)]			
Diagonal plan dimension [See Section 131.0465]		applies	applies

Footnote for Table 131-04E [No change.]

§ 131.0443 Setback Requirements in Residential Zones

(a) *Setbacks* in RE and RS Zones

(1) [No change.]

(2) ~~Front Setbacks in all RE Zones and the RS 1-1, RS 1-2, RS 1-3, RS 1-4, RS 1-5, RS 1-6, RS 1-7 Zones~~

~~For lots where at least one half of the front 50 feet of the lot depth has a minimum slope gradient of 25 percent, the setback closest to the street frontage may be reduced to a minimum of 6 feet.~~

~~(3) Side and Street Side Setbacks in all RE Zones and the RS 1-1, RS 1-2, RS 1-3, RS 1-4, RS 1-5, RS 1-6, RS 1-7 Zones.~~

~~(A) For lots exceeding 50 feet in width, each side setback shall be at least the dimension shown in Tables 131-04C and 131-04D or 10 percent of the width of the lot, whichever is greater, except one side setback may observe the minimum~~

~~dimension shown in Tables 131-04C and 131-04D as long as the combined dimensions of both side setbacks equals at least 20 percent of the lot width. Once a side setback is established, all additions to the primary structure thereafter shall maintain the established side setback.~~

~~(B) The street side setback is at least the dimension shown in Tables 131-04C and 131-04D or 10 percent of the lot width, whichever is greater.~~

~~(C) For lots with 40 to 50 feet in width, each side setback is a minimum of 4 feet.~~

~~(D) For lots with less than 40 feet in width, each side setback may be reduced to 10 percent of the lot width but shall not be reduced to less than 3 feet.~~

~~(E) For irregularly shaped lots, such as pie shaped lots, the setbacks are based on the average lot width for the first 50 feet of lot depth.~~

~~(F) For consolidated lots, the width for determining setback requirements is the width of the premises after the consolidation.~~
~~(4) Rear Setback in all RE Zones and the RS-1-1, RS-1-2, RS-1-3, RS-1-4, RS-1-5, RS-1-6, RS-1-7 Zones~~

(A) The required rear *setback* is at least the dimension shown in Table 131-04D, except as follows:

- (i) For *lots with* less than 100 feet in depth, the rear *setback* is at least 10 percent of the lot depth, but not less than 5 feet; and
- (ii) For *lots with* greater than 150 feet in depth, the rear *setback* is at least 10 percent of the lot depth or the dimension shown in Tables 131-04C and 131-04D, whichever is greater.

(B) and (C) [No change.]

(53) Rear *Setback* in the RS-1-8, RS-1-9, RS-1-10, RS-1-11, RS-1-12, RS-1-13, and RS-1-14 Zones

For *lots* that are served by *alley* access, the rear *setback* may be reduced to 4 feet.

(b) through (i) [No change.]

§131.0444 Angled Building Envelope Plane/ Maximum Structure Height in Residential Zones

- (a) ~~In the RE zones, a structure may exceed the 30-foot height limit to a maximum of 35 feet if the front, side, and rear setbacks are each increased by 10 feet, except where structure height is limited by the regulations in Chapter 13, Article 2 (Overlay Zones).~~(b) ~~In the RS-1-1, RS-1-2, RS-1-~~

~~3, RS 1-4, RS 1-5, RS 1-6, and RS 1-7 zones, structure height shall not exceed the height of the building envelope. Abutting the required front, side, and street side yards, the height of the building envelope above 24 feet is established by the angled building envelope planes shown in Table 131-04H up to the maximum permitted 30-foot structure height, as shown in Diagram 131-04L. If the maximum structure height does not exceed 27 feet, the angle above 24 feet is required only at the side yards.~~

Maximum structure height shall not exceed the height of the angled building envelope plane, which connects the maximum structure height adjacent to the setback and the overall maximum structure height as determined by the underlying base zone and the requirements below. Encroachments beyond the building envelope are subject to the requirements in Section 131.0461.

(b) The angle of the building envelope plane is based on lot width as established in Table 131-04H.

**Table 131-04H
Required Angle Building Envelope Plane**

Lot Width: h	Angle of Plane ¹
Less than 75 feet	45 degrees
75 feet to 150 feet	30 degrees
Greater than 150 feet	0 degrees <u>Not Applicable</u>

Footnote for Table 131-04H

¹ The angled planes are measured from the vertical axis inward.

(c) The maximum structure height requirements for the RS-1-1, RS-1-2, RS-1-3, RS-1-4, RS-1-5, RS-1-6, RS-1-7, and RX zones are stated in Tables

131-04D and 131-04E. The angled *building envelope* plane shall be required adjacent to required side *yards*. Angled *building envelope* planes are also required adjacent to front and street side *yards* in cases where the maximum *structure height* exceeds 27 feet. The angled *building envelope* plane shall be measured in accordance with Diagram 131-04L.

Diagram 131-04L [No Change]
Angled Building Envelope Planes in RS, RX, and RT Zones

- ~~(c) In the RS-1-1, RS-1-2, RS-1-3, RS-1-4, RS-1-5, RS-1-6, RS-1-7, RM-1-1, RM-1-2, RM-1-3 and RX-zones chimneys and *dormers* may project into the space above the angled *building envelope* planes to a maximum *structure height* of 30 feet. *Dormers* encroaching into the space above the angled *building envelope* are subject to the provisions in Sections 131.0461(a)(9) and 131.0461(b)(6) (Architectural Projections and Encroachments).~~
- (d) ~~In the RX-zones, the *structure height* shall not exceed the height of the *building envelope*. Abutting the required front, side, and street side yards, the height of the *building envelope* above 24 feet is established by a 45-degree angled *building envelope* plane up to the maximum permitted 30-foot *structure height*. If the maximum *structure height* does not exceed 27 feet in height, the 45-degree angled *building envelope* plane is required only along the side *yards*. The angled *building envelope* planes shall be measured in accordance with Diagram 131-04L.~~ (e) ~~In the RT-zone, for~~

The maximum structure height requirements for RT zones are stated in Table 131-04F. For buildings with a slab foundation, the maximum permitted *structure height* is 21 feet for one- and two-story *structures* or 31 feet for three-story *structures*. For buildings with a conventional raised floor, the maximum permitted *structure height* is 25 feet for one- and two-story *structures* or 35 feet for three-story *structures*. For buildings with sloped roofs with at least a 3:12 pitch (3 vertical feet to 12 horizontal feet), the maximum permitted *structure height* is increased by 5 feet. In all cases, unless otherwise excepted, the height of the *building envelope* above 27 feet adjacent to the front *setback line* is established by a 30-degree angled *building envelope* plane slanting inward to the maximum permitted *structure height*. The angled *building envelope* planes shall be measured in accordance with Diagram 131-04L.

(f) ~~Structure Height Requirements in~~ The maximum structure height requirements for the RM-1-1, RM-1-2, ~~RM-1-3 Zones (1)~~ ~~Structure height shall not exceed the height of the~~ and RM-1-3 zones are stated in Table 131-04G. The angled building envelope, Established plane requirements apply as follows:

(A1) At the front *setback line*, the height of the *building envelope* above 19 feet at the minimum *setback* and 24 feet at the standard setback, is established by a 45-degree angled *building envelope* plan

sloping inward to the maximum permitted 30- foot *structure height* limit, as shown in Diagram 131-04M.

~~Exception: The *building envelope* may have a projection outside the angled *building envelope* area for up to 33 percent of the width of the *building envelope* facing the front yard. The maximum depth of the projection shall be equal to or less than its width. See Diagram 131-04N.~~

~~Chimneys may project into the space above the angled *building envelope* planes to a maximum height of 30 feet.~~

Diagram 131-04M [No Change]
Angled Building Envelope at Front Setback

~~(B) — The *building envelope* may have a projection outside the angled *building envelope* area for up to 33 percent of the width of the *building envelope* facing the front yard. The maximum depth of the projection shall be equal to or less than its width. See Diagram 131-04N.~~

Diagram 131-04N
Exception for Angled Building Envelope Area

~~(C2)~~ At the side *setback line*, the height of the *building envelope* above 24 feet in height is established by a 45-degree *building envelope* plane sloping inward to the maximum permitted 30-foot *structure height*.

~~(2) — Dormers may project into the space above the 45-degree angled building envelope planes, as shown in Diagram 131-04O, subject to the following:~~

~~(A) — A dormer may not extend beyond a height of 30 feet;~~

~~(B) — The aggregate width of a dormer may not exceed 30 percent of the length of the roof plan to which the dormers will be attached;~~

~~(C) — Each dormer may not exceed 8 feet in width measured at the widest point; and~~

~~(D) — There shall be at least 4 feet between each dormer.~~

Diagram 131-04O
Dormer Projection Beyond Angled Building Envelope Plane

~~(g) — Structure Height Requirements in RM-2-4, RM-2-5, RM-2-6 Zones~~

~~(1) — Structure height shall not exceed the height of the building envelope, established as follows:~~
f) The maximum structure height requirements for the RM-2-4, RM-2-5, and RM-2-6 zones are stated in Table 131-04G. At the side setback lines, the maximum height of the building envelope above 30 feet in height is established by a 60-degree angled building envelope plane sloping inward from the side setback lines to the maximum permitted 40-foot structure height.

~~(2) — Dormer may project into the space above the 60-degree angled building envelope planes, as shown in Diagram 131-04O subject to the following:~~

~~(A) — The aggregate width of dormers may not exceed 50 percent of the length of the roof plan to which the dormers will be attached; and~~

~~(B) — Dormers may not extend beyond a height of 40 feet.~~

§131.0448 Accessory Structures in Residential Zones

(a) Multiple *accessory buildings* are permitted on a *premises*. However the square footage of all *accessory buildings* cannot exceed 25 percent of the allowable *gross floor area* of the *premises*.

(b) ~~An~~No *accessory building* ~~in the RE, RS, and RX zones~~may be used for living or sleeping purposes. An accessory building may have electrical, gas, and water/sewer connections to provide the following activities:

(1) through (3) [No change.]

(c) *Accessory buildings* ~~in RE, RS, and RX zones~~ may encroach into required *yards* subject to the ~~following conditions:~~requirements in Section [131.0461](#).

~~(1) — Encroachment into required yards can only occur on premises with less than 10,000 square feet of area.~~

- ~~(2) — Accessory buildings, not including attached or detached patio, shall be limited to one story.~~
- ~~(3) — The maximum permitted structure height of an accessory building is 10 feet for a flat roof and 15 feet for a pitched roof. If the structure contains a shed roof, the maximum structure height is 12 feet measured at the ridge. A building with a flat roof may have a roof deck, provided that all handrails and other appurtenances are limited to 42 inches in height and comply with all setback requirements.~~
- ~~(4) — All required visibility areas, as set forth in Section 113.0273, shall be observed.~~
- ~~(5) — No accessory building shall be used for living or sleeping purposes.~~
- ~~(6) — In the RE and RS zones, the cumulative area of all accessory buildings encroaching into required yards shall not exceed 525 square feet in gross floor area.~~
- ~~(7) — In the RX zones, the cumulative area of all accessory buildings shall not exceed 400 square feet in gross floor area.~~
- ~~(8) — The length of any accessory building dimension within the required yards shall not exceed 30 feet in any given setback.~~

~~(9) — The *accessory building* must be placed entirely within the rear 30 percent of the *lot premises* or behind the front 70 feet of the *lot premises*, whichever results in the *accessory building* being located farther from the *street*.~~

~~(10) — If the *accessory building* is used for parking and access to the *structure* is taken from the *alley*, a minimum distance of 21 feet shall be provided between the edge of the *alley* opposite the *premises* and the exterior wall of the *accessory building*.~~

~~(11) — Within the Coastal Overlay Zone, *accessory structures* are subject to the supplemental regulations in Section 132.0403.~~

(d) *Structures containing uses regulated by Chapter 14, Article 1 (Separately Regulated Uses)* are not subject to Section 131.0448.

§131.0449 Garage Regulations in Residential Zones

(a) Garages within an ~~Existing Embankment~~ existing embankment in the RE, RS, and RX Zones Attached or detached garages, not exceeding 12 feet in height, including parapets and handrails, may encroach into the front and street side yards, as shown in Diagram 131-04PN, subject to the following conditions:

(1) through (8) [No change.]

Diagram 131-04PN [No change in Diagram]
Garage Within Existing Embankment

(b) Garages in RT Zones

(1) through (7) [No change.]

(8) [No change.]

(A) A court yard with minimum dimensions of 10 feet by 10 feet must be provided within the rear 50 percent of the *lot*, as shown in Diagram 131-04~~Q~~O, or within the dwelling unit. The court yard shall extend the full height of the *structure* and must be at least 75 percent open to sunlight;

Diagram 131-04~~Q~~O [No change.]
Courtyard Requirement with Attached Garage

(B) and (C) [No change.]

(9) [No change.]

§131.0453 Lot Consolidation Regulations in the RM-1-1 and RM-1-2 Zones

[No change.]

(a) Any building on a consolidated *premises* may cross only one previous *property line*, as shown in Diagram 131-04~~R~~P;

(b) If the consolidation results in a total *street frontage* exceeding 60 feet, the number of dwelling units permitted within any single building shall not exceed the number of units that would have been permitted on the largest *premises* before the consolidation, as shown in Diagram 131-04~~R~~P;

Diagram 131-04RP [No change in Diagram]
Buildings on Consolidated Lots

- (c) [No change.]
- (d) Within the front 50 percent of the consolidated *premises*, a minimum 3-foot offset in the front facade shall be required for any building where the dimension most parallel to the *street* exceeds one-and-one-half times the width of the permitted *building envelope* of the largest *lot* existing before consolidation. See Diagram 131-04SQ.

Diagram 131-04SQ [No change in Diagram.]
Lot Consolidation Offset Requirement

§131.0455 Private Exterior Open Space in the RM Zones

- (a) In the RM-1-1, RM-1-2, and RM-1-3 zones, at least 60 square feet of usable, private, exterior open space abutting each dwelling unit shall be provided with a minimum dimension of 6 feet in any direction. The open space may be located in required *yard* areas, but shall be no closer than 9 feet to the front or rear *property lines*, and no closer than 4 feet to the side *property lines*. See Diagram 131-04TR.

Diagram 131-04TR [No change in Diagram.]
Private Exterior Open Space

- (b) through (d) [No change.]

§131.0461 Architectural Projections and Encroachments in Residential Zones

(a) The following are permitted *architectural projections* and *encroachments* into required yards [and the angled building envelope plane](#) for RS and RX zones and the RM-1-1, RM-1-2, and RM-1-3 zones. These projections and *encroachments* are not permitted in the required yards within view corridors that are designated by *land use plans* in the Coastal Overlay Zone and may not be located in a required *visibility area* or a required turning radius or vehicle back-up area except where development regulations may allow.

(1) [No change.]

(2) Openly supported *architectural projections*, including trellises, may encroach into required yards, as shown in Diagram 131-04US, subject to the following:

(A) through (F) [No change.]

Diagram 131-04US [No change in Diagram]
Openly Supported Architectural Projections

(3) Bay windows may project into required yards, as shown in Diagram 131-04VT, subject to the following requirements:

(A) through (E) [No change.]

Diagram 131-04VT [No change in Diagram]
Bay Window Yard Projections

(4) Fireplace enclosures may encroach into required yards and the angled building envelope plane subject to the following requirements:

(A) through (D) [No change.]

(5) ~~Electrical~~Mechanical equipment such as air conditioner units, gas meters, electrical fuse boxes, ~~gas meters, or pool equipment~~ and associated utility enclosures may encroach into required side and rear yards subject to the following requirements:

~~(A) — The encroachment into the required yard shall not exceed 18 inches;~~

(A) At-grade equipment shall be located a minimum of 4 feet from the property line; and

(B) ~~The encroachment shall not be closer than~~Equipment that is located completely below finished grade, with a permanent, durable, protective cover shall be permitted to encroach up to 2 feet, 6 inches to~~from~~ the property line;

~~(C) — The encroachment shall not exceed a width of 6 feet and a height of 8 feet; and~~

~~(D) — No more than one of each of these types of encroachments is permitted per building elevation.~~

(6) [No change.]

(7) Entry arbors may encroach into required front and street side yards, as shown in Diagram 131-04~~W~~U, subject to the following requirements:

(A) through (H) [No change.]

Diagram 131-04~~W~~U [No change.]
Entry Arbor Yard Projections

(8) [No change.]

(9) *Dormers* are permitted to encroach into required yards and into the ~~sloped~~angled building envelope plane subject to the following:

(A) [No change.]

(B) A *dormer* may not exceed ~~8~~10 feet in width, measured at the building wall;

(C) through (E) [No change.]

Diagram 131-04V
Dormer Projection into Angled Building Envelope Plane

[Transferred from Section 131.0444 (previously Diagram 131-04O): Revise maximum length of dormer in Diagram from 8 feet to 10 feet.]

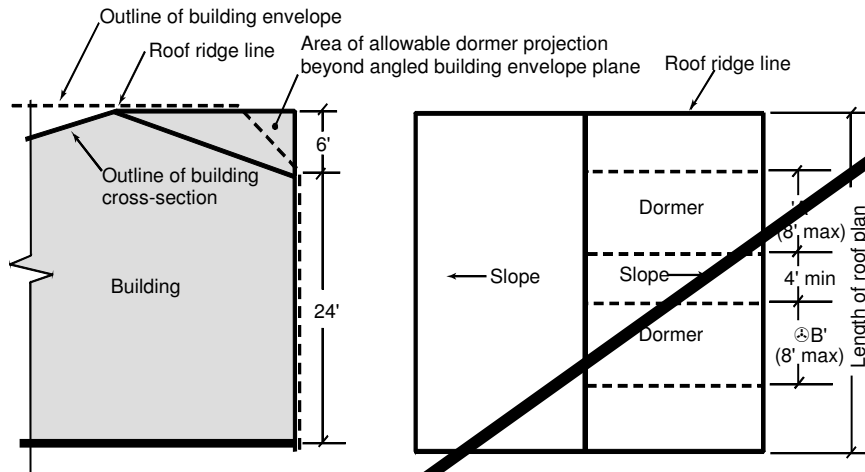

NOTE: Total width of dormer projections ('A' + 'B') shall not exceed 30% of length of r
in RM -1-1, RM -1-2, RM -1-3 zones or 50% of length of roof plan
in RM -2-4, RM -2-5, RM -2-6 zones.

Section

Roof Plan

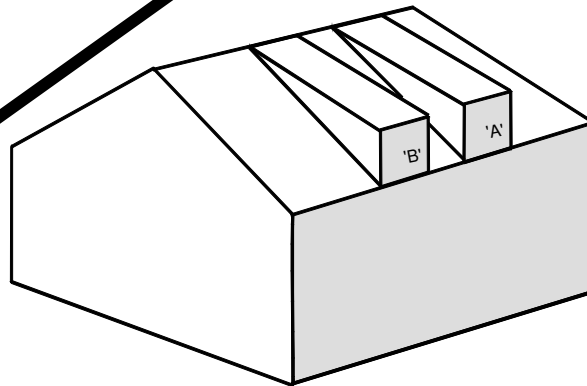

3-Dimension

Diagram 131-04V
Dormer Projection into Angled Building Envelope Plane

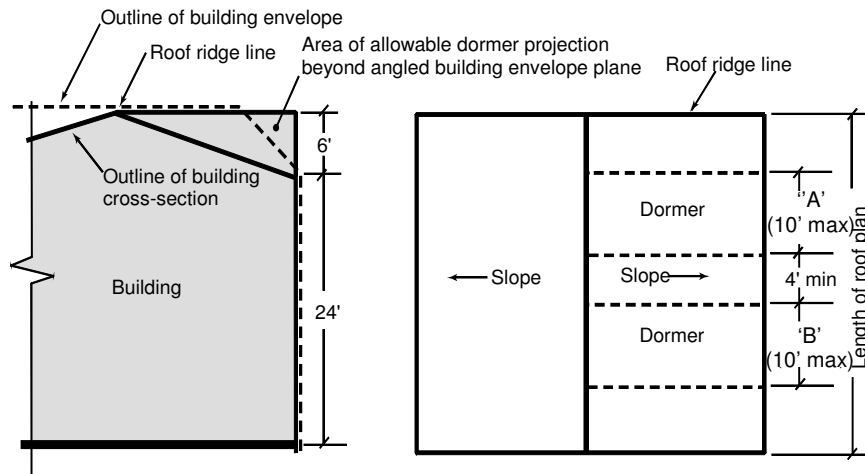

NOTE: Total width of dormer projections ('A' + 'B') shall not exceed 30% of length of r in RM -1-1, RM -1-2, RM -1-3 zones or 50% of length of roof plan in RM -2-4, RM -2-5, RM -2-6 zones.

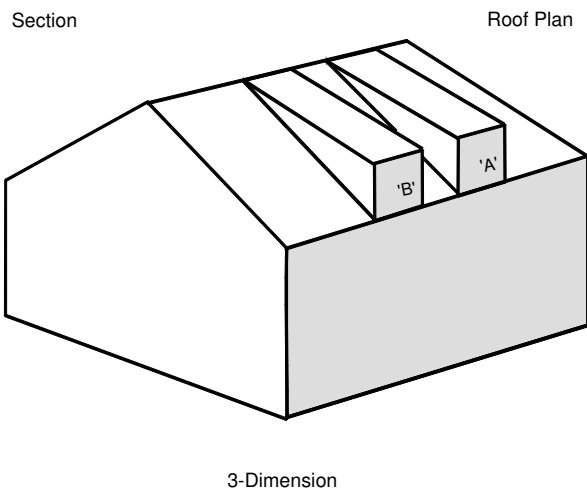

(10) [No change.]

(11) Swimming pools, spas, and hot tubs are permitted within a required yard subject to the following:

(A) Swimming pools that project 3 feet or less above grade may be located a minimum of 3 feet from the property line.

(B) Swimming pools that project greater than 3 feet above grade are not permitted to encroach within a required *street yard* or interior side *yard setback*, but may encroach into the rear *yard setback* if located a minimum of 4 feet from the rear *property line*.

(12) Detached garages or *accessory buildings* may encroach into a required side or rear *yard* as follows:

(A) The *lot* size shall not exceed 10,000 square feet of area; and

(B) The *accessory building* shall be limited to one *story* and a maximum *structure* height of 15 feet; and

(C) The *accessory building* shall not exceed a maximum length of 30 feet within any given *setback*; and

(D) The cumulative area of all encroaching *accessory buildings* shall not exceed 525 square feet in *gross floor area*.

- (b) The following are permitted *architectural projections* and *encroachments* into the required front and street side *yard* for the RT zones. A maximum of 50 percent of the area of the required minimum front *yard* (the front 5 feet of the *lot*) may be used for *encroachments*. See Section 131.0464(c) for required building articulation features. No permitted projection or *encroachment* may be located in a required *visibility area* or a required

turning radius or vehicle back-up area except where development regulations may allow.

(1) through (5) [No change.]

(6) *Dormers* may project into required minimum front and street side *yards* subject to the following requirements:

(A) [No change.]

(B) The maximum width of *dormers* shall be ~~5~~10 feet; and

(C) [No change.]

(7) [No change.]

(c) In the RM-2-4, RM-2-5, RM-2-6, RM-3-7, RM-3-8, RM-3-9, RM-4-10, RM-4-11, and RM-5-12 zones, architectural *encroachments* listed in Section 131.0461(a) are permitted with the following limitations. No permitted projection or *encroachment* may be located in required *yards* within view corridors that are designated by *land use plans* in the Coastal Overlay Zone or in a required *visibility area* or a required turning radius or vehicle back-up area except where development regulations may allow.

(1) through (3) [No change.]

(4) *Dormers may project into the angled building envelope plane as follows:*

(A) The aggregate width of *dormers* may not exceed 50 percent of the length of the roof plan to which the *dormers* will be attached; and

(B) Dormers may not extend beyond a height of 40 feet.

~~§131.0465 — Diagonal Plan Dimension in Residential Zones~~

~~For new *structures* in the RS 1-7 zone and all RX zones, a maximum diagonal plan dimension applies to *lots* where the depth is three times the width, as follows:~~

~~a) — The maximum diagonal plan dimension shall not exceed 150 percent of the width of the *lot*, as shown in Diagram 131-04Z.~~

**~~Diagram 131-04Z
Maximum Diagonal Plan Dimension~~**

~~(b) — The maximum diagonal plan dimension shall be measured between the two most extreme points on the *structure*. If the *structure* is irregular in shape, the maximum diagonal plan dimension may be measured between the first extreme building point and the point of the first building modulation along the length of the building with subsequent measurements allowed between modulations, as shown in Diagram 131-04AA. A modulation shall have a minimum 4-foot differential and shall extend for a minimum of 10 feet in length.~~

Diagram 131-04AA
Diagonal Plan Dimension Modulations

§131.0515 Where Commercial Zones Apply

On the effective date of Ordinance O-18692, all commercial zones that were established in Municipal Code Chapter 10, Article 1, Division 4 ~~shall be~~ were amended and replaced with the base zones established in this division, ~~as shown~~ in ~~Table 131-05A~~.

Table 131-05A
Commercial Zone Applicability

Previous Chapter 10 Commercial Zone Replaced with New Commercial Zone Established by this Division	
Commercial Zone that Existed on December 31 1999.	Applicable Zone of this Division
CN	CN-1-2
CA	CC-1-3
CA-RR	CC-2-3
CC	CC-3-5
CO	CO-1-2
CR	CV-1-1
CV	CV-1-2
C, C (PCOZ)	CC-4-5
C-1	CC-4-2
C-1 (PCOZ)	CC-4-4
CBD	CR-1-1
CP	CP-1-1
No Existing Zone	CN-1-1, CN-1-3
No Existing Zone	CC-1-1, CC-1-2,
No Existing Zone	CC-2-1, CC-2-2
No Existing Zone	CC-3-4
No Existing Zone	CC-4-1, CC-4-3
No Existing Zone	CC-5-1, CC-5-2, CC-5-3, CC-5-4 CC-5-5
No Existing Zone	CR-2-1
No Existing Zone	CO-1-1

§131.0615 Where Industrial Zones Apply

On the effective date of Ordinance O-18691, all industrial zones that were established in Municipal Code Chapter 10, Article 1, Division 4 ~~shall be~~ were amended and replaced with the base zones established in this division, ~~as shown in Table 131-06A.~~

**Table 131-06A
Industrial Zone Applicability**

Previous Chapter 10 Industrial Zone Replaced with New Industrial Zone Established by this Division	
Industrial Zone That Existed on December 31 1999.	Applicable Zone of this Division
SR	IP-1-1
M-IP	IP-2-1
M-1B	HL-2-1
M-SI	IS-1-1
M-1, M1-A	HL-3-1
M-2, M-2A, M-LI	HH-2-1
No Existing Zone	HL-1-1
No Existing Zone	HH-1-1

§143.0410 General Development Regulations for Planned Development Permits

~~The following regulations are applicable to *developments* for which a Planned Development Permit is requested when identified in Table 143-04A.~~

- (a) [No change.]
- (b) *Density* and Intensity
 - (1) The number of dwelling units or total *gross floor area* to be built on the *premises* shall not exceed that set forth by the

applicable zone and the applicable *land use plan* except as permitted by 143.0410(a)(3)(D), and shall be based on the area of the entire *premises*. The dwelling units or *gross floor area* may be distributed without regard to the proposed *lot* boundaries.

(2) through (5) [No change.]

(c) through (j) [No change.]

SRE:pev
09/24/08
1003/08 COR.COPY
Or.Dept:DSD
O-2009-31
MMS #6574