



THE CITY OF SAN DIEGO
REPORT TO THE PLANNING COMMISSION

DATE ISSUED: April 26, 2012 **REPORT NO. PC-12-043**

ATTENTION: Planning Commission, Agenda of May 3, 2012

SUBJECT: Sprint Nextel – Jutland - PROJECT NO. 255594. PROCESS 5.

**OWNER/
APPLICANT:** FIRST BAPTIST CHURCH OF CLAIREMONT/
SPRINT NEXTEL

SUMMARY

Issue(s): Should the Planning Commission recommend approval, to the City Council, for a Wireless Communication Facility (WCF), at 3219 Clairemont Mesa Boulevard, in the Clairemont Mesa community plan area?

Staff Recommendation:

1. Recommend Approval of Conditional Use Permit No. 960026; and,
2. Recommend Approval of Site Development Permit No. 960027; and,
3. Recommend Approval of Planned Development Permit No. 978521.

Community Planning Group Recommendation: The Clairemont Mesa Community Planning Group recommended approval of this project at their November 15, 2011 meeting (Attachment 12).

Environmental Review: This project is not pending an appeal of the environmental determination. The environmental exemption determination for this project was made on February 8, 2012, and the opportunity to appeal that determination ended February 23, 2012.

Fiscal Impact Statement: Sprint/Nextel is the Financially Responsible Party responsible for costs associated with the processing of this application.

Code Enforcement Impact: Not applicable.

Housing Impact Statement: Not applicable.

BACKGROUND

Sprint/Nextel – Jutland is an application for a Conditional Use Permit (CUP), Site Development Permit (SDP), and Planned Development Permit (PDP) for a Wireless Communication Facility (WCF). The project is located on the First Baptist Church of Clairemont at 3219 Clairemont Mesa Boulevard, within the RM-1-1 zone of the Clairemont Mesa community plan area (Attachments 1, 2, 3, and 4).

This WCF was originally approved with permit number 41-0081-02, issued on February 27, 2001, which expired February 27, 2011. This application is for a new permit, subject to the current regulations.

WCF's are permitted in residential zones with a non-residential use where the antennas are less than 100 feet from the property line of a day care, elementary school, middle school, or residential use with the processing of a CUP, Process 3. In this situation, there is a day care on site and a CUP, Process 3 is required.

The height limits for the RM-1-1 and the Clairemont Mesa Height Limit Overlay zones are both 30'. The height of the WCF, at 34'3", exceeds the 30' height limit. To allow this deviation, a Planned Development Permit, Process 4, is required to deviate from the RM-1-1 zone height limit and a Site Development Permit, Process 5, is required to deviate from the Clairemont Mesa Height Limit Overlay Zone.

DISCUSSION

Project Description:

The WCF consists of a total of 12 panel antennas mounted behind radio-frequency transparent screening. The screening material will be designed to integrate with the existing building by texturing, painting, and trim (Attachment 8). Equipment associated with the antennas is located within a 200 square foot enclosure adjacent to the existing building. Existing and proposed street trees will help screen and integrate the WCF with the neighborhood.

The existing facility will be modified by improving the screening material, adding trim elements, and extending the screening to conceal views from all sides of the WCF. Four 24-inch box size street trees will be added to fill in gaps in the existing street tree planting, which will improve views of the facility.

Community Plan Analysis:

The Clairemont Mesa Community Plan does not specifically address WCF's. However, the City's General Plan, Section UD-A.15, does address WCF's as follows:

Minimize the visual impact of wireless facilities.

- a) Conceal wireless facilities in existing structures when possible, otherwise use camouflage and screening techniques to hide or blend them into the surrounding area.
- b) Design facilities to be aesthetically pleasing and respectful of the neighborhood context.
- c) Conceal mechanical equipment and devices associated with wireless facilities in underground vaults or unobtrusive structures.

This project complies with the requirements of the General Plan for WCF's. The antennas are located within architectural elements on an existing building. The architectural elements are designed to integrate with the existing building and conceal the antennas behind radio-frequency transparent screens.

Conclusion:

This project complies with the applicable regulations of the Land Development Code and the City's General Plan. The Clairemont Mesa Community Planning Group has recommended approval of the project and draft findings (Attachment 5) have been made in the affirmative. Therefore, staff recommends that the Planning Commission recommend approval of CUP No. 960026, SDP No. 960027, and PDP No. 978521.

ALTERNATIVES

- 1. Recommend **Approval** of CUP No. 960026, SDP No. 960027, and PDP No. 978521, with modifications.
- 2. Recommend **Denial** of CUP No. 960026, SDP No. 960027, and PDP No. 978521, **if the Planning Commission makes written findings based on substantial evidence that the approval is not authorized by state or local zoning law.**

Respectfully submitted,



Mike Westlake
Program Manager
Development Services Department



Alex Hempton, AICP
Associate Planner
Development Services Department

BROUGHTON/AFH

Attachments:

1. Aerial Photo
2. Community Plan Land Use Map
3. Project Location Map
4. Project Data Sheet
5. Draft Permit Resolution with Findings
6. Draft Permit with Conditions
7. Notice of [Environmental] Exemption (NOE)
8. Photo Simulations
9. Site Justification
10. Coverage Maps
11. Project Plans
12. Balboa Park Committee Recommendation
13. Ownership Disclosure Statement
14. Project Chronology
15. Notice of Planning Commission Hearing
16. Photographic Survey

Rev 01-06/11 hmd

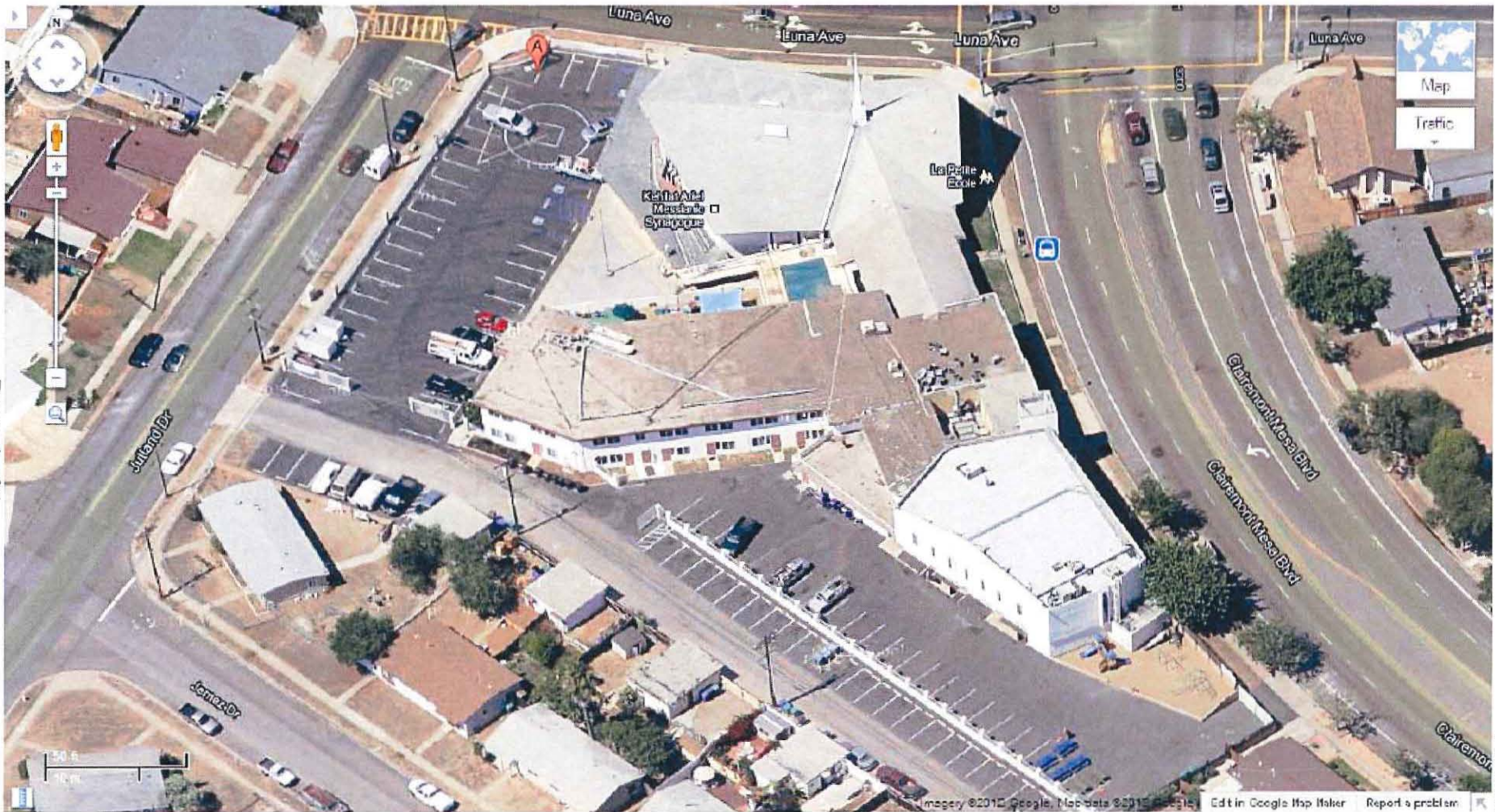

Aerial Photo

Sprint Nextel - Jutland – Project Number 255594

3219 Clairemont Mesa Boulevard

Designated as residential.

Dwelling Units per Net Residential Acre

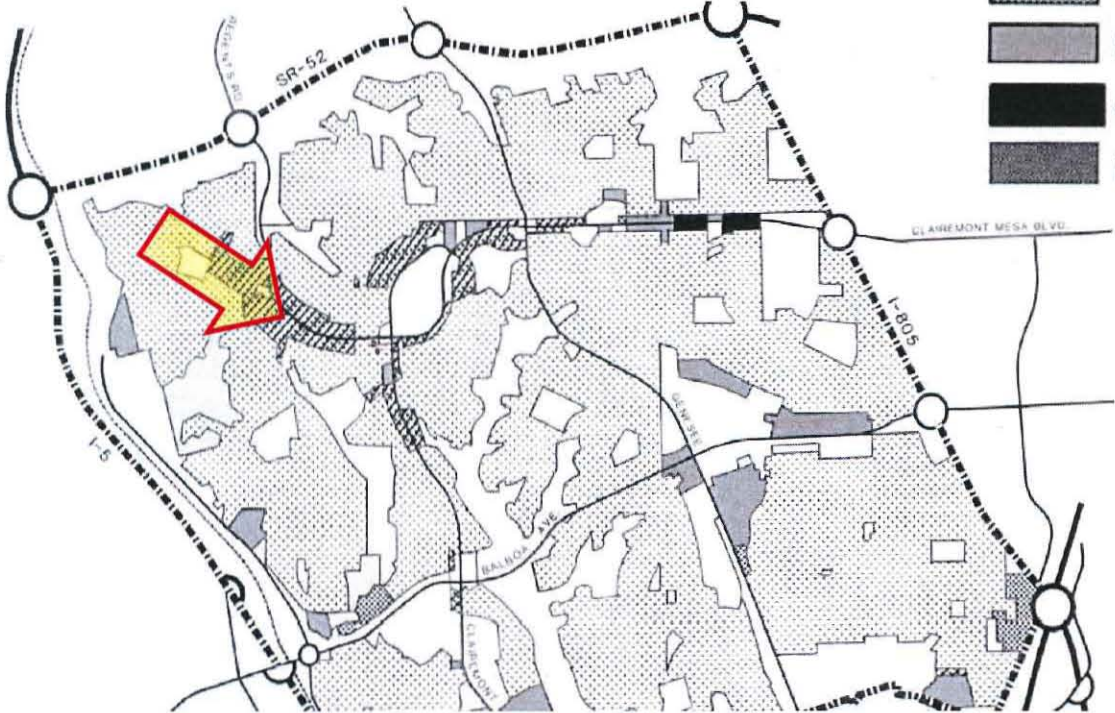
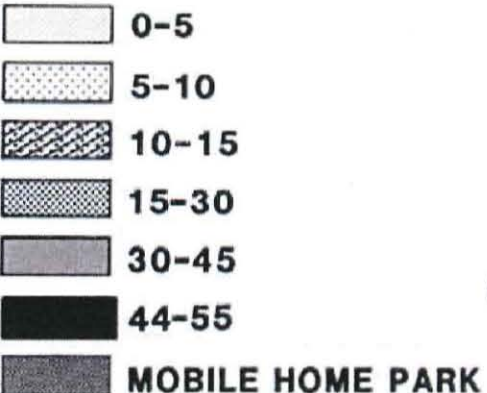

Community Plan Land Use Map

Sprint Nextel - Jutland – Project Number 255594

3219 Clairemont Mesa Boulevard

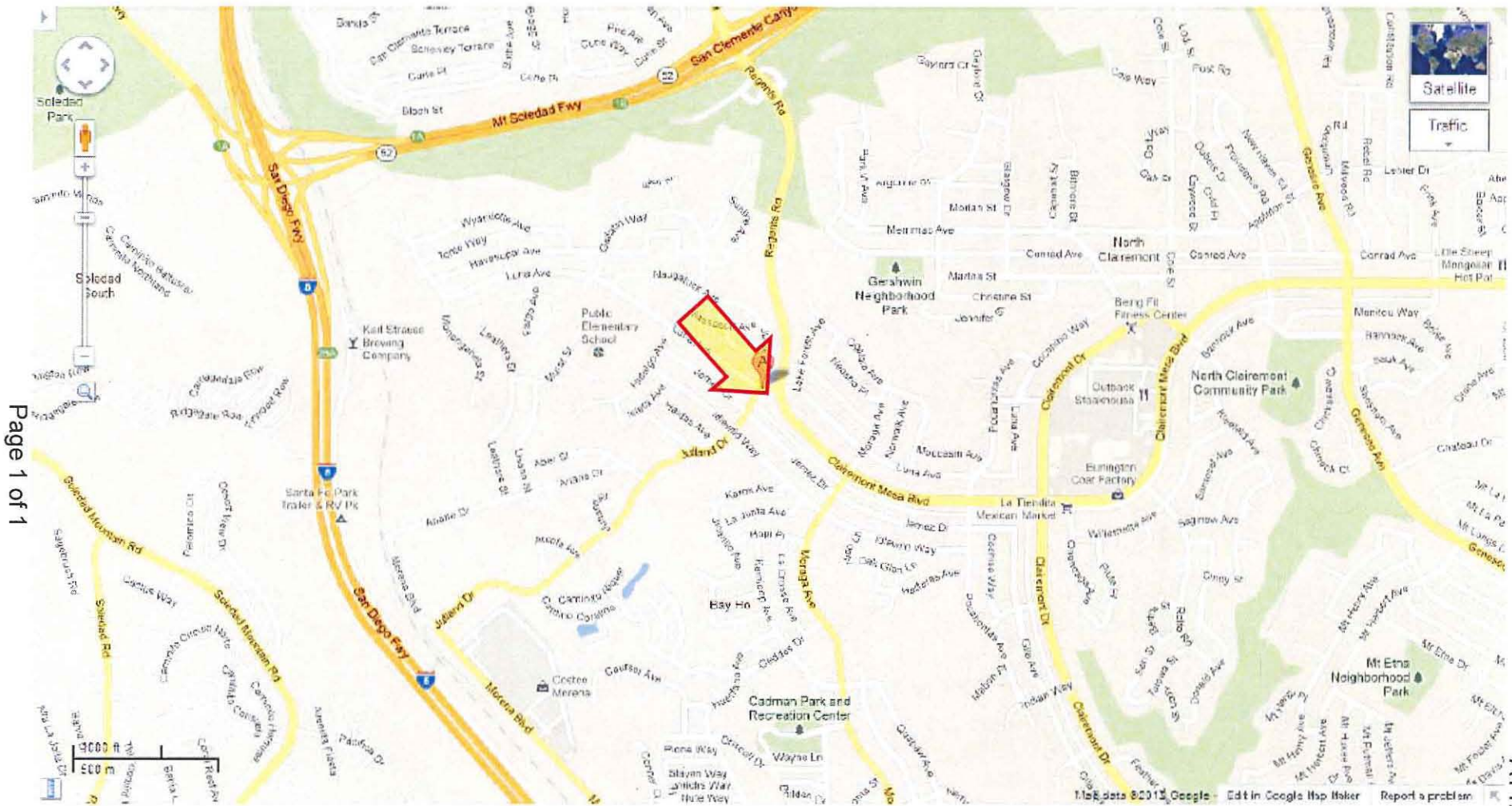

Page 1 of 1



Project Location Map
Sprint Nextel - Jutland – Project Number 255594
3219 Clairemont Mesa Boulevard



ATTACHMENT 3

PROJECT DATA SHEET		
PROJECT NAME:	Sprint Nextel - Jutland	
PROJECT DESCRIPTION:	Conditional Use Permit, Planned Development Permit, and Site Development Permit, Process 5, for a Wireless Communication Facility (WCF) consisting of antennas mounted behind radio-frequency transparent materials designed to integrate with the existing building. Equipment associated with the antennas is located adjacent to an existing building within an enclosure.	
COMMUNITY PLAN AREA:	Clairemont Mesa	
DISCRETIONARY ACTIONS:	Conditional Use Permit, Planned Development Permit, and Site Development Permit (Process 5)	
COMMUNITY PLAN LAND USE DESIGNATION:	Residential	
<u>ZONING INFORMATION:</u>		
ZONE: RM-1-1 HEIGHT LIMIT: 30' FRONT SETBACK: 15'/20' SIDE SETBACK: 5'/8' STREETSIDE SETBACK: 10' REAR SETBACK: 15'		
<u>ADJACENT PROPERTIES:</u>	LAND USE DESIGNATION & ZONE	EXISTING LAND USE
NORTH:	Residential, RM-1-1	Residential
SOUTH:	Residential, RM-1-1	Residential
EAST:	Residential, RM-1-1	Residential
WEST:	Residential, RM-1-1	Residential
DEVIATIONS OR VARIANCES REQUESTED:	Requests deviation from the 30-foot height limit of the Clairemont Mesa Height Limit Overlay Zone and the 30-foot height limit of the RM-1-1 zone.	
COMMUNITY PLANNING GROUP RECOMMENDATION:	On November 15, 2011, the Clairemont Mesa community planning group approved the project.	

**PLANNING COMMISSION RECOMMENDATION TO CITY COUNCIL
RESOLUTION NO. XXXX-PC
CONDITIONAL USE PERMIT NO. 960026
PLANNED DEVELOPMENT PERMIT NO. 978521
SITE DEVELOPMENT PERMIT NO. 960027
SPRINT NEXTEL - JUTLAND
PROJECT NO. 255594**

WHEREAS, FIRST BAPTIST CHURCH OF CLAIREMONT, Owner, and SPRINT NEXTEL, Permittee, filed an application with the City of San Diego for a permit to construct, operate, and maintain a Wireless Communication Facility (WCF) (as described in and by reference to the approved Exhibits "A" and corresponding conditions of approval for the associated Permit Nos. 960026, 978521 and 960027);

WHEREAS, the project site is located at 3219 Clairemont Mesa Boulevard, in the RM-1-1 zone of the Clairemont Mesa community plan area;

WHEREAS, the project site is legally described as Lots 2124, 2125, 2126, 2127, and 2041 of Clairemont Unit No. 10, in the City of San Diego, County of San Diego, State of California, according to Map Thereof No. 2929, filed in the Office of the County Recorder of Said County, November 19, 1952;

WHEREAS, on February 8, 2012, the City of San Diego, as Lead Agency, through the Development Services Department, made and issued an Environmental Determination that the project is exempt from the California Environmental Quality Act (CEQA) (Public Resources Code section 21000 et. seq.) under CEQA Guideline Section 15301(b) (Existing Facilities – Public or Private Utilities) and there was no appeal of the Environmental Determination filed within the time period provided by San Diego Municipal Code Section 112.0520;

WHEREAS, on May 3, 2012, the Planning Commission of the City of San Diego considered Conditional Use Permit No. 960026, Planned Development Permit No. 978521, and Site Development Permit No. 960027 pursuant to the Land Development Code of the City of San Diego;

NOW, THEREFORE, BE IT RESOLVED by the Planning Commission of the City of San Diego as follows:

That the Planning Commission adopts the following written Findings, dated May 3, 2012:

FINDINGS:

Conditional Use Permit - Section 126.0305

1. The proposed development will not adversely affect the applicable land use plan;

The City's General Plan (UD-15) requires that the visual impact of wireless facilities be minimized by concealing wireless facilities in existing structures or using screening techniques to hide or blend them into the surrounding area. The plan also calls for these facilities to be designed to be aesthetically pleasing and respectful of the neighborhood context. Furthermore, the plan states that equipment associated with wireless facilities be concealed from view. In this case, the WCF consists of antennas concealed within architectural elements added to the existing

building, designed to make the antennas appear to be integral parts of the building's design. The antennas will be surrounded by radio-frequency transparent screening material, painted and textured to match adjacent building surfaces. A trim element will be added and all sides of the antennas will be enclosed. Four additional street trees will be added to the existing street trees to help improve views of the WCF as seen from the public right-of-way. The design of the facility is respectful of the neighborhood context and does not adversely affect the applicable land use plan.

2. The proposed development will not be detrimental to the public health, safety, and welfare;

The Telecommunication Act of 1996 preempts local governments from regulating the “placement, construction and modification of wireless communication facilities on the basis of the environmental effects of Radio Frequency (RF) emissions to the extent that such facilities comply with the Federal Communication Commission’s (FCC) standards for such emissions.” The proposed project would be consistent with the FCC’s regulations for wireless facilities. To insure that the FCC standards are being met, a condition has been added to the permit to require that Sprint/Nextel perform a cumulative model RF test and submit the finding in a report to the City of San Diego prior to the issuance of a building permit. (Note: This condition is in addition to LDC section 141.0420(b)(1)(A), which requires compliance with federal and state standards and regulations with regards to WCF’s.) Therefore, based on the above, the project would not result in any significant health or safety risks to the surrounding area within the jurisdiction of the City.

3. The proposed development will comply with the regulations of the Land Development Code including any allowable deviations pursuant to the Land Development Code; and

This project complies with the regulations of the Land Development Code, specifically the WCF Regulations, LDC 141.0420. WCF’s are permitted in residential zones, with a non-residential use, where the antennas are located less than 100 feet from the property line of a day care, elementary school, middle school, or residential use with the processing of a Conditional Use Permit, Process 3. In this case, a day care operates on site, so a Conditional Use Permit, Process 3 is required to permit the WCF. The design of the facility complies with the WCF Design Requirements, by locating the antennas behind radio-frequency transparent screening material, painted and textured to integrate with the existing building. Equipment is located within an enclosure adjacent to the building. Four additional street trees are being added to supplement the existing street trees to improve the appearance of the facility as viewed from the public right-of-way. Portions of the WCF exceed the 30-foot height limits of the RM-1-1 zone and the Clairemont Mesa Height Limit Overlay Zone. To allow these deviations, a Planned Development Permit (Process 4) is being processed to deviate from the 30-foot height limit of the RM-1-1 zone and a Site Development Permit (Process 5) is being processed to deviate from the 30-foot Clairemont Mesa Height Limit Overlay Zone. Therefore, the project complies with the regulations of the Land Development Code, including allowable deviations pursuant to the processing of the PDP and SDP, processed as part of this project.

4. The proposed use is appropriate at the proposed location.

WCF are permitted in residential zones with a non-residential use, where a day care is located on the premises, with the processing of a Conditional Use Permit, Process 3. The WCF Regulations and Council Policy 600-43 incentivize the locating of WCF’s away from residential zones. The

preferred location for WCF's are in commercial or industrial zones, however wireless carriers are required to provide coverage to all areas within their license. In this case, the locating of this facility in a residential zone with a non-residential use is more preferable than locating the facility in a residential zone with a residential use. The WCF is permitted with the processing of this Conditional Use Permit, Process 3 and based on the project's compliance with the WCF Design Requirements and the City's General Plan, is appropriate at the proposed location.

Planned Development Permit - Section 126.0604

1. The proposed development will not adversely affect the applicable land use plan;

The City's General Plan (UD-15) requires that the visual impact of wireless facilities be minimized by concealing wireless facilities in existing structures or using screening techniques to hide or blend them into the surrounding area. The plan also calls for these facilities to be designed to be aesthetically pleasing and respectful of the neighborhood context. Furthermore, the plan states that equipment associated with wireless facilities be concealed from view. In this case, the WCF consists of antennas concealed within architectural elements added to the existing building, designed to make the antennas appear to be integral parts of the building's design. The antennas will be surrounded by radio-frequency transparent screening material, painted and textured to match adjacent building surfaces. A trim element will be added and all sides of the antennas will be enclosed. Four additional street trees will be added to the existing street trees to help improve views of the WCF as seen from the public right-of-way. The design of the facility is respectful of the neighborhood context and does not adversely affect the applicable land use plan.

2. The proposed development will not be detrimental to the public health, safety, and welfare;

The Telecommunication Act of 1996 preempts local governments from regulating the "placement, construction and modification of wireless communication facilities on the basis of the environmental effects of Radio Frequency (RF) emissions to the extent that such facilities comply with the Federal Communication Commission's (FCC) standards for such emissions." The proposed project would be consistent with the FCC's regulations for wireless facilities. To insure that the FCC standards are being met, a condition has been added to the permit to require that Sprint/Nextel perform a cumulative model RF test and submit the finding in a report to the City of San Diego prior to the issuance of a building permit. (Note: This condition is in addition to LDC section 141.0420(b)(1)(A), which requires compliance with federal and state standards and regulations with regards to WCF's.) Therefore, based on the above, the project would not result in any significant health or safety risks to the surrounding area within the jurisdiction of the City.

3. The proposed development will comply with the regulations of the Land Development Code including any proposed deviations pursuant to Section 126.0602(b)(1) that are appropriate for this location and will result in a more desirable project than would be achieved if designed in strict conformance with the development regulations of the applicable zone; and any allowable deviations that are otherwise authorized pursuant to the Land Development Code.

This project complies with the regulations of the Land Development Code, specifically the WCF Regulations, LDC 141.0420. WCF's are permitted in residential zones, with a non-residential

use, where the antennas are located less than 100 feet from the property line of a day care, elementary school, middle school, or residential use with the processing of a Conditional Use Permit, Process 3. In this case, a day care operates on site, so a Conditional Use Permit, Process 3 is required to permit the WCF. The design of the facility complies with the WCF Design Requirements, by locating the antennas behind radio-frequency transparent screening material, painted and textured to integrate with the existing building. Equipment is located within an enclosure adjacent to the building. Four additional street trees are being added to supplement the existing street trees to improve the appearance of the facility as viewed from the public right-of-way. Portions of the WCF exceed the 30-foot height limits of the RM-1-1 zone and the Clairemont Mesa Height Limit Overlay Zone. To allow these deviations, a Planned Development Permit (Process 4) is being processed to deviate from the 30-foot height limit of the RM-1-1 zone and a Site Development Permit (Process 5) is being processed to deviate from the 30-foot Clairemont Mesa Height Limit Overlay Zone. The deviation of 4'3" to the 30-foot height limit of the RM-1-1 zone is appropriate at this location as it results in a design that screens and integrates the antennas with the existing building in a way that is respectful of the neighborhood context and in compliance with the WCF Design Requirements. The increase in height allows for a better design and a project that is more desirable than designed in strict conformance with the development regulations of the RM-1-1 zone. Therefore, the project complies with the regulations of the Land Development Code, including allowable deviations pursuant to the processing of the PDP and SDP, processed as part of this project.

Site Development Permit - Section 126.0504

1. The proposed development will not adversely affect the applicable land use plan;

The City's General Plan (UD-15) requires that the visual impact of wireless facilities be minimized by concealing wireless facilities in existing structures or using screening techniques to hide or blend them into the surrounding area. The plan also calls for these facilities to be designed to be aesthetically pleasing and respectful of the neighborhood context. Furthermore, the plan states that equipment associated with wireless facilities be concealed from view. In this case, the WCF consists of antennas concealed within architectural elements added to the existing building, designed to make the antennas appear to be integral parts of the building's design. The antennas will be surrounded by radio-frequency transparent screening material, painted and textured to match adjacent building surfaces. A trim element will be added and all sides of the antennas will be enclosed. Four additional street trees will be added to the existing street trees to help improve views of the WCF as seen from the public right-of-way. The design of the facility is respectful of the neighborhood context and does not adversely affect the applicable land use plan.

2. The proposed development will not be detrimental to the public health, safety, and welfare; and

The Telecommunication Act of 1996 preempts local governments from regulating the "placement, construction and modification of wireless communication facilities on the basis of the environmental effects of Radio Frequency (RF) emissions to the extent that such facilities comply with the Federal Communication Commission's (FCC) standards for such emissions." The proposed project would be consistent with the FCC's regulations for wireless facilities. To insure that the FCC standards are being met, a condition has been added to the permit to require that Sprint/Nextel perform a cumulative model RF test and

submit the finding in a report to the City of San Diego prior to the issuance of a building permit. (Note: This condition is in addition to LDC section 141.0420(b)(1)(A), which requires compliance with federal and state standards and regulations with regards to WCF's.) Therefore, based on the above, the project would not result in any significant health or safety risks to the surrounding area within the jurisdiction of the City.

- 3. The proposed development will comply with the applicable regulations of the Land Development Code, including any allowable deviations pursuant to the Land Development Code.**

This project complies with the regulations of the Land Development Code, specifically the WCF Regulations, LDC 141.0420. WCF's are permitted in residential zones, with a non-residential use, where the antennas are located less than 100 feet from the property line of a day care, elementary school, middle school, or residential use with the processing of a Conditional Use Permit, Process 3. In this case, a day care operates on site, so a Conditional Use Permit, Process 3 is required to permit the WCF. The design of the facility complies with the WCF Design Requirements, by locating the antennas behind radio-frequency transparent screening material, painted and textured to integrate with the existing building. Equipment is located within an enclosure adjacent to the building. Four additional street trees are being added to supplement the existing street trees to improve the appearance of the facility as viewed from the public right-of-way. Portions of the WCF exceed the 30-foot height limits of the RM-1-1 zone and the Clairemont Mesa Height Limit Overlay Zone. To allow these deviations, a Planned Development Permit (Process 4) is being processed to deviate from the 30-foot height limit of the RM-1-1 zone and a Site Development Permit (Process 5) is being processed to deviate from the 30-foot Clairemont Mesa Height Limit Overlay Zone. Therefore, the project complies with the regulations of the Land Development Code, including allowable deviations pursuant to the processing of the PDP and SDP, processed as part of this project.

Supplemental SDP Findings - Clairemont Mesa Height Limit

- 4. The granting of an exception will not significantly interfere with public views from western Clairemont Mesa to Mission Bay and the Pacific Ocean within the surrounding area; and**

The granting of a 4'3" deviation from the 30-foot Clairemont Mesa Height Limit Overlay Zone will not significantly interfere with public views from western Clairemont Mesa to Mission Bay and the Pacific Ocean within the surrounding area. The architectural element which is part of this project, at 34'3", is minimal in size and appearance, with a sloped design, which does not significantly interfere with public views.

- 5. The granting of an exception is appropriate because there are existing structures over 30 feet in height and the proposed development will be compatible with surrounding one, two, or three-story structures; or the granting of an exception is appropriate because there are topographic constraints peculiar to the land; or the granting of the exception is needed to permit roofline and facade variations, accents, tower elements, and other similar elements and the elements will not increase the floor area of the structure.**

The granting of an exception is appropriate because there are existing structures over 30' in height and the proposed development will be compatible with surrounding structures. Portions of the existing buildings on the premises reach 35' and an existing steeple structure reaches 45'6". The architectural screening, part of this project, at 34'3", is compatible in design with the existing building and respectful of the surrounding neighborhood development.

BE IT FURTHER RESOLVED that, based on the findings hereinbefore, the Planning Commission recommends to the City Council that, CONDITIONAL USE PERMIT NO. 960026, PLANNED DEVELOPMENT PERMIT NO. 978521, and SITE DEVELOPMENT PERMIT NO. 960027, hereby be GRANTED by the Planning Commission to the referenced Owner/Permittee, in the form, exhibits, terms and conditions as set forth in Permit Nos. 960026, 978521, and 960027, a copy of which is attached hereto and made a part hereof.

Alexander Hempton, AICP
Associate Planner
Development Services

Adopted on: May 3, 2012

Internal Order No. 24002125

RECORDING REQUESTED BY
CITY OF SAN DIEGO
DEVELOPMENT SERVICES
PERMIT INTAKE, MAIL STATION 501

WHEN RECORDED MAIL TO
PROJECT MANAGEMENT
PERMIT CLERK
MAIL STATION 501

SPACE ABOVE THIS LINE FOR RECORDER'S USE

INTERNAL ORDER NUMBER: 24002125

CONDITIONAL USE PERMIT NO. 960026
PLANNED DEVELOPMENT PERMIT NO. 978521
SITE DEVELOPMENT PERMIT NO. 960027
SPRINT NEXTEL - JUTLAND
PROJECT NO. 255594
CITY COUNCIL

This **CONDITIONAL USE PERMIT (CUP) NO. 960026**, **PLANNED DEVELOPMENT PERMIT (PDP) NO. 978521**, and **SITE DEVELOPMENT PERMIT NO. 960027** are granted by the **City Council** of the City of San Diego to **FIRST BAPTIST CHURCH OF CLAIREMONT**, Owner, and **SPRINT NEXTEL**, Permittee, pursuant to San Diego Municipal Code [SDMC] sections 126.0305, 126.0604, 126.0504, and 141.0420. The site is located at 3219 Clairemont Mesa Boulevard, in the RM-1-1 zone of the Clairemont Mesa community plan area. The project site is legally described as Lots 2124, 2125, 2126, 2127, and 2041 of Clairemont Unit No. 10, in the City of San Diego, County of San Diego, State of California, according to Map Thereof No. 2929, filed in the Office of the County Recorder of Said County, November 19, 1952.

Subject to the terms and conditions set forth in this Permit, permission is granted to Owner/Permittee to construct, operate, and maintain a Wireless Communication Facility (WCF), described and identified by size, dimension, quantity, type, and location on the approved exhibits [Exhibit "A"] dated XXXX, on file in the Development Services Department.

The project shall include:

- a. Twelve panel antennas mounted behind two radio-frequency transparent structures, located on the roof of an existing building, and painted and textured to match the existing building;
- b. A 200 square foot equipment enclosure located adjacent to the existing building;
- c. A deviation to the 30-foot height limits (allowing portions of the WCF to reach heights of 34'3") of the RM-1-1 zone and the Clairemont Mesa Height Limit Overlay Zone,

which are permitted with the processing of this Planned Development Permit and Site Development Permit, respectively;

- d. Landscaping (planting, irrigation and landscape related improvements);
- e. Accessory improvements determined by the Development Services Department to be consistent with the land use and development standards in effect for this site per the adopted community plan, California Environmental Quality Act Guidelines, public and private improvement requirements of the City Engineer, the underlying zone(s), conditions of this Permit, and any other applicable regulations of the SDMC in effect for this site.

STANDARD REQUIREMENTS:

1. This permit must be utilized within thirty-six (36) months after the date on which all rights of appeal have expired. Failure to utilize and maintain utilization of this permit as described in the SDMC will automatically void the permit unless an Extension of Time has been granted. Any such Extension of Time must meet all SDMC requirements and applicable guidelines in affect at the time the extension is considered by the appropriate decision maker. This permit must be utilized by May 17, 2015.
2. No permit for the construction, occupancy or operation of any facility or improvement described herein shall be granted, nor shall any activity authorized by this Permit be conducted on the premises until:
 - a. The Owner/Permittee signs and returns the Permit to the Development Services Department; and
 - b. The Permit is recorded in the Office of the San Diego County Recorder.
3. Unless this Permit has been revoked by the City of San Diego the property included by reference within this Permit shall be used only for the purposes and under the terms and conditions set forth in this Permit unless otherwise authorized by the Development Services Department.
4. This Conditional Use Permit [CUP] and corresponding use of this site shall expire on XXXXXXXX, 2022. Upon expiration of this Permit, the facilities and improvements described herein shall be removed from this site and the property shall be restored to its original condition preceding approval of this Permit.
5. No later than ninety (90) days prior to the expiration of this permit, the Owner/Permittee may submit a new application to the City Manager for consideration with review and a decision by the appropriate decision maker at that time. Failure to submit prior to the deadline will be cause for enforcement for noncompliance, which may include penalties and fines.
6. Under no circumstances, does approval of this permit authorize the Owner/Permittee to utilize this site for wireless communication purposes beyond the permit expiration date. Use of this permit beyond the expiration date of this permit is prohibited.

7. This Permit is a covenant running with the subject property and shall be binding upon the Permittee and any successor or successors, and the interests of any successor shall be subject to each and every condition set out in this Permit and all referenced documents.
8. The continued use of this Permit shall be subject to the regulations of this and any other applicable governmental agency.
9. Issuance of this Permit by the City of San Diego does not authorize the Permittee for this permit to violate any Federal, State or City laws, ordinances, regulations or policies including, but not limited to, the Endangered Species Act of 1973 [ESA] and any amendments thereto (16 U.S.C. § 1531 et seq.).
10. The Permittee shall secure all necessary building permits. The Permittee is informed that to secure these permits, substantial modifications to the building and site improvements to comply with applicable building, fire, mechanical and plumbing codes and State law requiring access for disabled people may be required.
11. Construction plans shall be in substantial conformity to Exhibit "A." No changes, modifications or alterations shall be made unless appropriate application(s) or amendment(s) to this Permit have been granted.
12. All of the conditions contained in this Permit have been considered and have been determined to be necessary in order to make the findings required for this Permit. It is the intent of the City that the holder of this Permit be required to comply with each and every condition in order to be afforded the special rights which the holder of the Permit is entitled as a result of obtaining this Permit.

In the event that any condition of this Permit, on a legal challenge by the Permittee of this Permit, is found or held by a court of competent jurisdiction to be invalid, unenforceable, or unreasonable, this Permit shall be void. However, in such an event, the Permittee shall have the right, by paying applicable processing fees, to bring a request for a new permit without the "invalid" condition(s) back to the discretionary body which approved the Permit for a determination by that body as to whether all of the findings necessary for the issuance of the proposed permit can still be made in the absence of the "invalid" condition(s). Such hearing shall be a hearing de novo and the discretionary body shall have the absolute right to approve, disapprove, or modify the proposed permit and the condition(s) contained therein.

13. The applicant shall defend, indemnify, and hold harmless the City, its agents, officers, and employees from any and all claims, actions, proceedings, damages, judgments, or costs, including attorney's fees, against the City or its agents, officers, or employees, relating to the issuance of this permit including, but not limited to, any action to attack, set aside, void, challenge, or annul this development approval and any environmental document or decision. The City will promptly notify applicant of any claim, action, or proceeding and, if the City should fail to cooperate fully in the defense, the applicant shall not thereafter be responsible to defend, indemnify, and hold harmless the City or its agents, officers, and employees. The City may elect to conduct its own defense, participate in its own defense, or obtain independent legal counsel in defense of any claim related to this indemnification. In the event of such election,

applicant shall pay all of the costs related thereto, including without limitation reasonable attorney's fees and costs. In the event of a disagreement between the City and applicant regarding litigation issues, the City shall have the authority to control the litigation and make litigation related decisions, including, but not limited to, settlement or other disposition of the matter. However, the applicant shall not be required to pay or perform any settlement unless such settlement is approved by applicant.

LANDSCAPE REQUIREMENTS:

14. In the event that the Landscape Plan and the Site Plan conflict, the Site Plan shall be revised to be consistent with the Landscape Plan such that landscape areas are consistent with the Exhibit 'A' Landscape Development Plan.

15. Prior to issuance of any construction permits for buildings complete landscape and irrigation construction documents consistent with the Land Development Manual: Landscape Standards shall be submitted to the Development Services Department for approval. The construction documents shall be in substantial conformance with Exhibit 'A,' Landscape Development Plan, on file in the Office of the Development Services Department. Construction plans shall take into account a 40 square foot area around each tree which is unencumbered by hardscape and utilities as set forth under LDC 142.0403(b)5.

16. Prior to issuance of any Certificate of Occupancy, it shall be the responsibility of the Owner/Permittee to install all required landscape and obtain all required landscape inspections.

17. All required landscape shall be maintained in a disease, weed and litter free condition at all times. Severe pruning or "topping" of trees is not permitted. The trees shall be maintained in a safe manner to allow each tree to grow to its mature height and spread.

18. If any required landscape (including existing or new plantings, hardscape, landscape features, etc.) indicated on the approved construction document plans is damaged or removed during demolition or construction, it shall be repaired and/or replaced in kind and equivalent size per the approved documents to the satisfaction of the Development Services Department within 30 days of damage or Certificate of Occupancy or a Final Landscape Inspection or activation of WCF.

19. Any required planting that dies within 3 years of installation shall be replaced within 30 calendar days of plant death with the same size and species of plant material shown on the approved plan. Required shrubs or trees that die 3 years or more after installation shall be replaced with 15 gallon size or 60-inch box size material, respectively. Development Services may authorize adjustment of the size and quantity of replacement material where material replacement would occur in inaccessible areas or where the existing plant being replaced is larger than a 15 gallon shrub or 60-inch box tree.

PLANNING/DESIGN REQUIREMENTS:

20. A topographical survey conforming to the provisions of the SDMC may be required if it is determined, during construction, that there may be a conflict between the building(s) under

construction and a condition of this Permit or a regulation of the underlying zone. The cost of any such survey shall be borne by the Owner/Permittee.

21. Prior to the issuance of a construction permit, the Permittee shall provide certification providing evidence that the cumulative field measurements of radio frequency power densities for all antennas installed on the premises comply with federal standards.

22. All equipment, including transformers, emergency generators and air conditioners shall be designed and operated consistent with the City noise ordinance. Ventilation openings shall be baffled and directed away from residential areas. Vibration resonance of operating equipment in the equipment enclosures shall be eliminated.

23. Prior to obtaining a Construction Permit the following items must be illustrated on the construction drawings; coax cable tray, meters, telco, A/C units, generator receptacles, cable runs, bridges, dog houses and external ports. These appurtenances must be minimized visually so as to avoid the effect of changing the outward appearance of the project from what was approved on the exhibits.

24. The Owner/Permittee shall notify the City within 30 days of the sale or transfer of this site to any other provider or if the site is no longer operational requiring the removal and the restoration of this site to its original condition.

25. This wireless communication facility shall be removed or replaced if it is determined that the facility or components of the facility are obsolete.

26. Within 90 days of permit approval, no later than XXXXXX, 2012, the Owner/Permittee shall submit building construction documents implementing the modifications to the WCF identified as part of this permit.

27. Within 180 days of permit approval, no later than XXXXXX, 2012, the Owner/Permittee shall obtain a final telecom planning inspection and finalize the building permits associated with this WCF modification.

INFORMATION ONLY:

- Any party on whom fees, dedications, reservations, or other exactions have been imposed as conditions of approval of this development permit, may protest the imposition within ninety days of the approval of this development permit by filing a written protest with the City Clerk pursuant to California Government Code §66020.
- This development may be subject to impact fees at the time of construction permit issuance

APPROVED by the City Council of the City of San Diego on XXXXXXXX, 2012 by Resolution No. XXXXXXXX.

Permit Type/PTS Approval No.: CUP/960026
PDP/978521
and SDP/960027
Date of Approval: XXXXXXXX

AUTHENTICATED BY THE DEVELOPMENT SERVICES DEPARTMENT

Alexander Hempton, AICP
Associate Planner

**NOTE: Notary acknowledgment
must be attached per Civil Code
section 1189 et seq.**

**The undersigned Owner/Permittee, by execution hereof, agrees to each and every condition of
this Permit and promises to perform each and every obligation of Owner/Permittee hereunder.**

**FIRST BAPTIST CHURCH OF
CLAIREMONT**
Owner

By _____

SPRINT NEXTEL
Permittee

By _____
Stephen DeMars
Network Manager

**NOTE: Notary acknowledgments
must be attached per Civil Code
section 1189 et seq.**

NOTICE OF EXEMPTION

(Check one or both)

TO: X RECORDER/COUNTY CLERK
P.O. BOX 1750, MS A-33
1600 PACIFIC HWY, ROOM 260
SAN DIEGO, CA 92101-2422

FROM: CITY OF SAN DIEGO
DEVELOPMENT SERVICES DEPARTMENT
1222 FIRST AVENUE, MS 501
SAN DIEGO, CA 92101

 OFFICE OF PLANNING AND RESEARCH
1400 TENTH STREET, ROOM 121
SACRAMENTO, CA 95814

PROJECT NO.: 255594 PROJECT TITLE: Sprint Nextel Jutland

PROJECT LOCATION-SPECIFIC: 3219 Clairemont Mesa Boulevard, San Diego, CA 92177 (Lots 2124, 2125, 2126, 2127, and 2041 of Clairemont Unit 10 Map No 2929)

PROJECT LOCATION-CITY/COUNTY: San Diego/San Diego

DESCRIPTION OF NATURE AND PURPOSE OF THE PROJECT: Conditional Use Permit (CUP) and Site Development Permit (SDP) for a wireless communication facility (WCF). The existing permit is expiring and this is an application for a new permit to continue operation of the existing WCF. Antennas are rooftop mounted. Existing antennas are proposed to be relocated behind a screen which would be finished to match the existing building. Equipment associated with the antennas is located in a ground-level equipment enclosure. This project is located in the RM-1-1 zone within the Clairemont Mesa Community Planning Area in Council District 6.

NAME OF PUBLIC AGENCY APPROVING PROJECT: City of San Diego

NAME OF PERSON OR AGENCY CARRYING OUT PROJECT: Debra DePratti Gardner
13948 Calle Bueno Ganar
Jamul, CA 91935
619-726-8110

EXEMPT STATUS: (CHECK ONE)

- MINISTERIAL (SEC. 21080(b)(1); 15268);
- DECLARED EMERGENCY (SEC. 21080(b)(3); 15269(a));
- EMERGENCY PROJECT (SEC. 21080(b)(4); 15269 (b)(c))
- CATEGORICAL EXEMPTION: 15301 (b), Existing Facilities – public or private utilities
- STATUTORY EXEMPTIONS:

REASONS WHY PROJECT IS EXEMPT This project is exempt because the structure is existing, minimal construction would occur on the roof and the existing equipment shelter, the structure is not historic and no sensitive resources exist on or around the site, it would result in no adverse visual effects, no grading would occur and this would not include an expansion of use. In addition the project meets the criteria set forth in CEQA section 15301 (b) which allows for existing facilities – public or private utilities and the exceptions listed in CEQA section 15300.2 would not apply. Therefore, no adverse impacts would occur.

LEAD AGENCY CONTACT PERSON: Lizzi

TELEPHONE: (619) 619-446-5159

IF FILED BY APPLICANT:

- 1. ATTACH CERTIFIED DOCUMENT OF EXEMPTION FINDING.
- 2. HAS A NOTICE OF EXEMPTION BEEN FILED BY THE PUBLIC AGENCY APPROVING THE PROJECT?
 YES NO

IT IS HEREBY CERTIFIED THAT THE CITY OF SAN DIEGO HAS DETERMINED THE ABOVE ACTIVITY TO BE EXEMPT FROM CEQA

Mary Ann Human, Senior Planner
SIGNATURE/TITLE

2/8/12
DATE

CHECK ONE:
 SIGNED BY LEAD AGENCY
 SIGNED BY APPLICANT

DATE RECEIVED FOR FILING WITH COUNTY CLERK OR OPR:

JUTLAND

SITE ID #SD54XD907



LOCATION

3219 CLAIREMONT MESA BLVD.,
SAN DIEGO, CA 92177



EXISTING



PROPOSED

JUTLAND

SITE ID #SD54XC9D7



LOCATION 3219 CLAIREMONT MESA BLVD.,
SAN DIEGO, CA 92177



EXISTING



PROPOSED

EAST VIEW

**SD54XC907 – Jutland
3219 Clairemont Mesa Blvd, San Diego, CA 92117
TELECOM SITE JUSTIFICATION REPORT**

1. **Description of the location, type, capacity, field strength or power density, and calculated geographic service area of the proposed antenna or antenna array.**

LOCATION AND TYPE

Sprint will continue the operation of an existing communications facility at First Baptist Church of Clairemont, 3219 Clairemont Mesa Blvd. The renewal consists of 9 panel antennas mounted within existing parapet walls. There are 3 antennas on 3 sectors. The existing cabinets are located at on the ground adjacent to the existing building. This existing facility is unmanned, operating 24 hours a day. The only visits to the site will consist of any emergency calls as well as regular maintenance visits once every four to six weeks.

FREQUENCY AND POWER SPECIFICATIONS

The transmitting frequency for the Sprint system is 1990 – 1995 Megahertz. The receiving frequency is 1910 – 1915 Megahertz.

COVERAGE AND CAPACITY

The objective of the existing site is to continue Sprint coverage within the residential area to the northeast, south and west of the surrounding area. Please refer to the existing coverage map that illustrates the existing coverage gap. The site will provide coverage in a current gap and provide additional capacity, allowing more users to use the system simultaneously and will provide "off-load" capacity for adjacent sites currently operation within a 1-mile radius from this existing site (see attached map).

2. **Location of all existing, proposed and anticipated wireless communications facilities in the Applicant/Permittee's network located within a 1 mile radius from proposed site.**

Please see refer to justification map and to coverage maps.

3. **A description of how the proposed facility fits into, and is a necessary part of, the Applicant/Permittee's network.**

The objective of the existing site is to continue Sprint coverage within the residential area to the northeast, south and west of the surrounding area. Please refer to the existing coverage map that illustrates the existing coverage gap. The site will provide coverage in a current gap and provide additional capacity, allowing more users to use the system simultaneously and will provide "off-load" capacity for adjacent sites currently operation within a 1-mile radius from this existing site (see attached map).

SD54XC907 Jutland
Telecom Site Justification

4. **If the proposal does not include co-location, written documentation of all efforts made to co-locate at another site, and a justification for the decision not to co-locate.**

There is a second telecommunications facility (Cingular/AT&T) at this property.

5. **Discuss Alternative Sites and why they were not selected.**

This site is located on a residential – multiple unit use zone surrounded by residential and multiple dwelling units. This site is on-air and no alternatives were reviewed. The existing site was selected because of its height above the coverage area and ability to fill the coverage gap and connect to surrounding sites. There were no other non-residential alternatives reviewed.

6. **Noise Information for sites located near residential**

The existing equipment does not contain any HVAC units. Therefore, no noise disturbance will be generated for residential neighbors.

Official Zoning Map

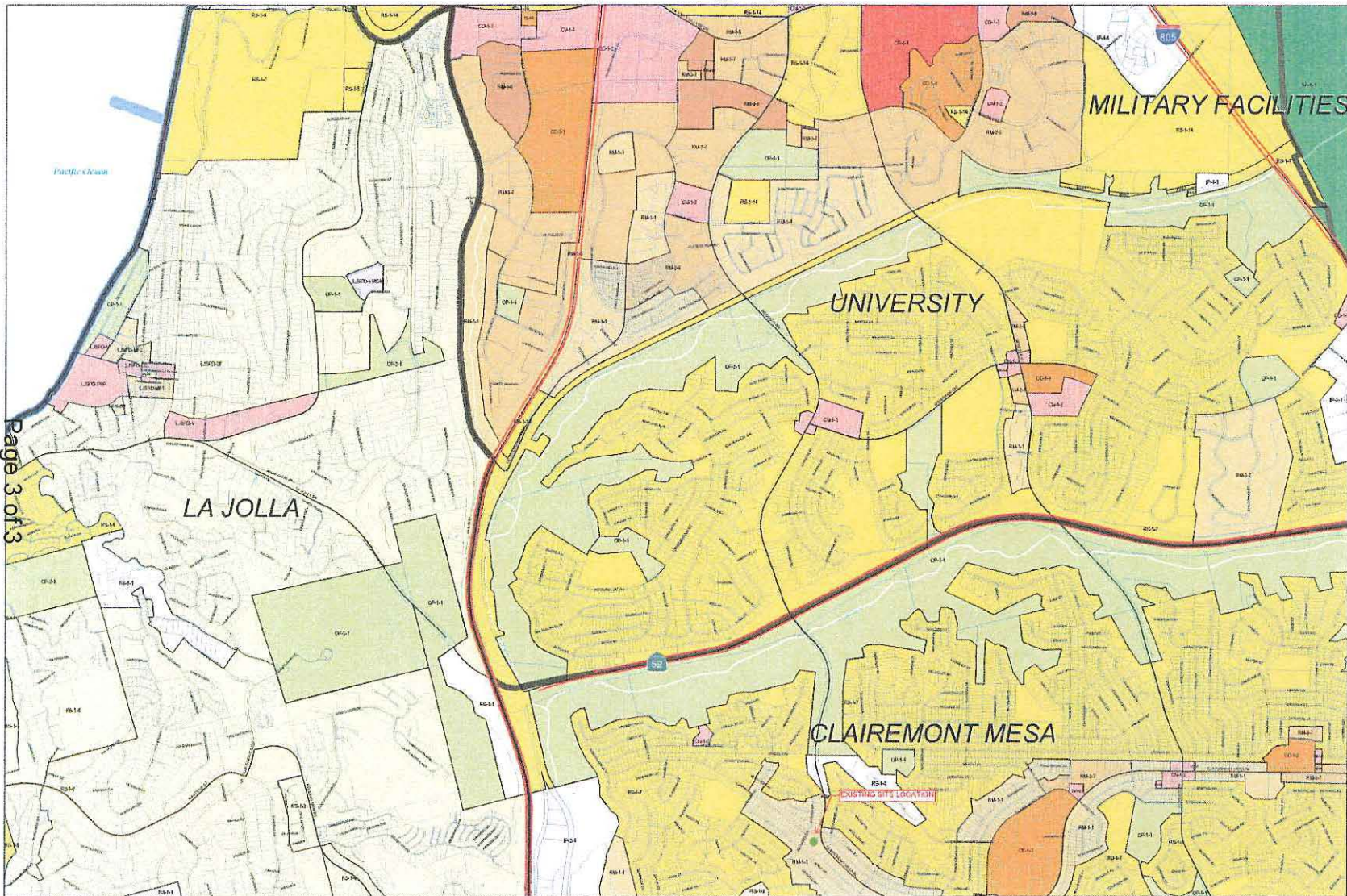

Legend

- City of San Diego Boundary
- Community Plan Areas
- Parcels

Zoning

ZONE NAME

- AR-1-1
- CC-1-3
- CN-1-2
- CO-1-2
- CP-1-1
- CR-1-1
- CV-1-1
- IP-1-1
- IP-2-1
- LJSPD-CC
- LJSPD-MF1
- LJSPD-MF2
- LJSPD-PRF
- LJSPD-SF
- LJSPD-V
- LJSPD-YMCA
- OP-1-1
- OP-2-1
- RM-1-1
- RM-1-2
- RM-2-5
- RM-3-7
- RM-3-9
- RM-4-10
- RS-1-1
- RS-1-14
- RS-1-2
- RS-1-3
- RS-1-4
- RS-1-5
- RS-1-7

Page 3 of 3

Index Map

			44	45	46	
			42	43		
	39	40	41			
	35	36	37	38		
	31	32	33	34		
26	27	28	29	30		
21	22	23	24	25		
	18	19	20			
	14	15	16	17		
	10	11	12	13		
		9				
		5	6	7		
		1	2	3		

ATTACHMENT 9

SanGIS Software Recovery
 SanGIS is a registered trademark of the City of San Diego. All other trademarks are the property of their respective owners.
 This software is provided "AS IS" without warranty of any kind, either expressed or implied, including but not limited to the warranties of merchantability and fitness for a particular purpose.
 If you are having trouble using this software, please contact the City of San Diego GIS Department at (619) 451-5000.

City of San Diego
 Development Services Department
 1210 La Jolla Village Drive, San Diego, CA 92161
 (619) 451-5000
 www.sandiego.gov



City of San Diego
Development Services Department



GRID TILE: 27
 GRID SCALE: 800
 DATE: 12/10/2008 5:19:18 PM

COVERAGE IN THE AREA WITHOUT SITE ON AIR SD54XC907

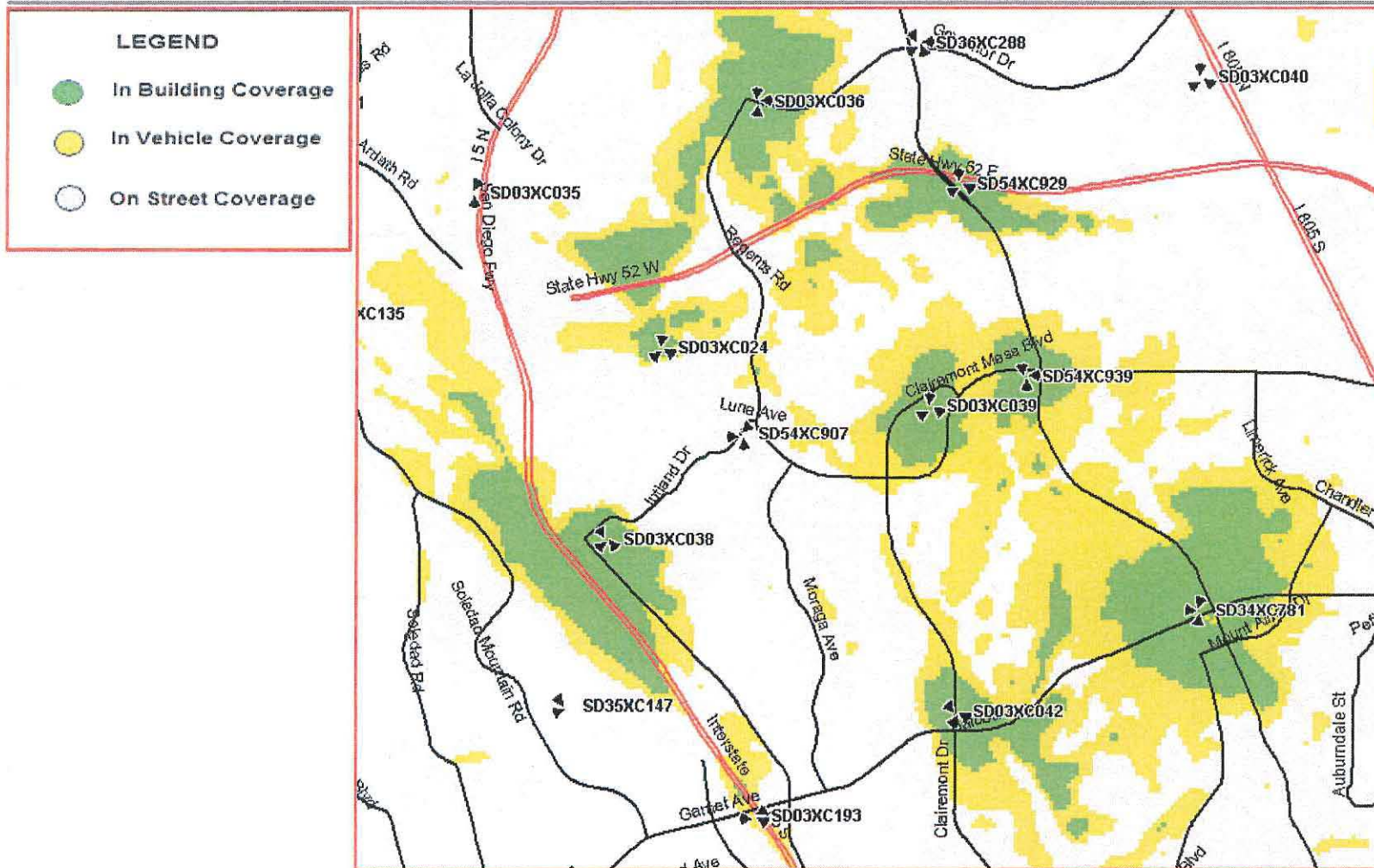

COVERAGE IN THE AREA WITH SITE ON AIR SD54XC907

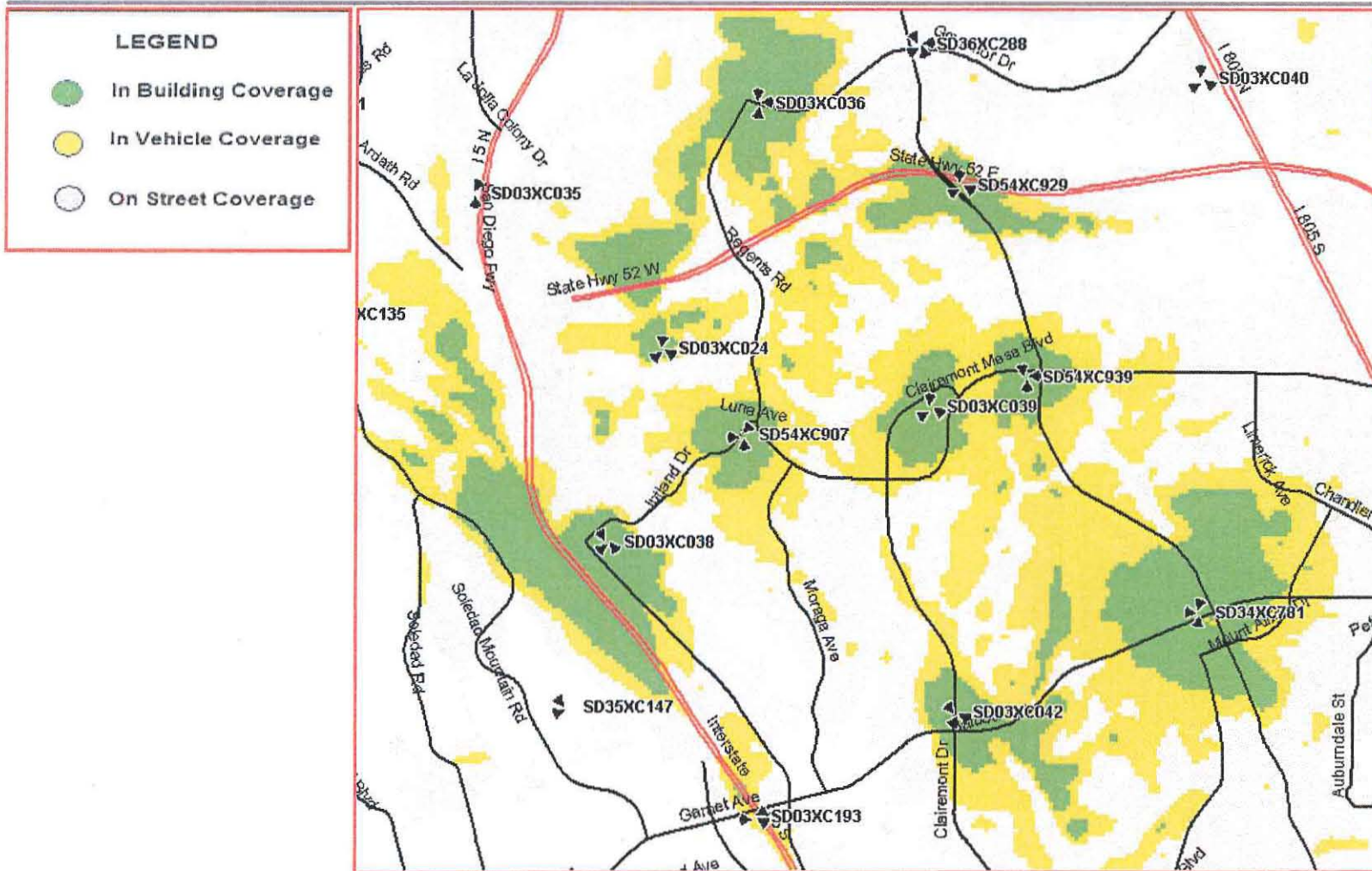

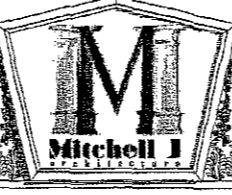

Sprint

Together with NEXTEL

SD54XC907 JUTLAND

3219 CLAIREMONT MESA BLVD SAN DIEGO CA, 92177

LEGAL DESCRIPTION

LOT 224, 225, 226, 227 AND 228 OF CLAREMONT UNIT NO. 10, IN THE CITY OF SAN DIEGO, COUNTY OF SAN DIEGO, STATE OF CALIFORNIA, ACCORDING TO MAP THEREOF NO. 2009, FILED IN THE OFFICE OF THE COUNTY RECORDER OF SAID COUNTY, NOVEMBER 19, 1982.

DIRECTIONS TO SITE

FROM IRVINE SPRINT NEXTEL OFFICE

1. TAKE I-8 SOUTH
2. TAKE EXIT 26 TO MERGE ONTO CA-52 EAST
3. EXIT CLAIREMONT MESA BLVD.
4. MERGE ONTO REGENTS RD
5. CONTINUE ONTO CLAIREMONT MESA BLVD.

ARRIVE AT 3219 CLAIREMONT MESA BLVD SAN DIEGO CA, 92177 ON THE RIGHT SIDE.



VICINITY MAP

CLIENT APPROVALS

RF INITIALS: _____ DATE _____

ARCHITECT INITIALS: _____ DATE _____

SITE ACQUISITION INITIALS: _____ DATE _____

ZONING/PLANNING INITIALS: _____ DATE _____

CONSTRUCTION INITIALS: _____ DATE _____

LANDLORD INITIALS: _____ DATE _____

TITLE 24 COMPLIANCE

ACCESSIBILITY DISCLAIMER

THIS PROJECT IS AN UNOCCUPIED WIRELESS TELECOMMUNICATIONS FACILITY AND, ACCORDING TO WRITTEN INTERPRETATION FROM THE CALIFORNIA DEPARTMENT OF THE STATE ARCHITECT, IS EXEMPT FROM DISABLED ACCESS REQUIREMENTS.

PROJECT STATEMENT

I HEREBY CERTIFY THAT THIS PROJECT COMPLIES TITLE 24, PART 6 OF THE CALIFORNIA STATE CODE.

SIGNED: _____



LEGAL DESCRIPTION

DIRECTIONS TO SITE

VICINITY MAP

CLIENT APPROVALS

TITLE 24 COMPLIANCE

APPLICABLE CODES

ALL WORK SHALL COMPLY WITH ALL APPLICABLE CODES, INCLUDING BUT NOT LIMITED TO:

1. 2010 CALIFORNIA BUILDING CODE (CBC) / 2009 INTERNATIONAL BUILDING CODE (IBC)
2. 2010 CALIFORNIA RESIDENTIAL CODE (CRC) / 2009 INTERNATIONAL RESIDENTIAL CODE (IRC)
3. 2010 CALIFORNIA ELECTRICAL CODE (CEC) / 2008 NATIONAL ELECTRICAL CODE (NEC)
4. 2010 CALIFORNIA MECHANICAL CODE (CMC) / 2009 UNIFORM MECHANICAL CODE (UMC)
5. 2010 CALIFORNIA PLUMBING CODE (CPC) / 2009 UNIFORM PLUMBING CODE (UPC)
6. 2010 CALIFORNIA FIRE CODE (CFC) / 2009 (IFC)
7. 2010 CALIFORNIA GREEN BUILDINGS STANDARDS CODE
8. 2008 BUILDING ENERGY EFFICIENCY STANDARDS

PROJECT SUMMARY

SITE NAME: JUTLAND
SITE NUMBER: SD54XC907
SITE ADDRESS: 3219 CLAIREMONT MESA SAN DIEGO CA, 92177

LANDLORD: FIRST BAPTIST CHURCH OF CLAREMONT 3219 CLAIREMONT MESA BLVD SAN DIEGO, CA 92177

ASSESSOR'S PARCEL #: 394-254-22
CURRENT ZONING: RH-1-1
(E) OCCUPANCY: A-2
(S) TYPE OF CONSTRUCTION: TYPE V-A

PROJECT DESCRIPTION:
SPRINT NEXTEL PROPOSES A NEW LUP TO MAINTAIN AN UNMANNED, DIGITAL MOBILE RADIO COMMUNICATIONS FACILITY AT THIS SITE. THE FACILITY CONSIST:

- EXISTING SPRINT NEXTEL (10'-3 1/2" x 7'-6") 100 S.F. PRE-FABRICATED EQUIPMENT SHELTER LOCATED AT GRADE INSIDE AN EXISTING CITY EQUIPMENT ENCLOSURE 250 S.F.
- EXISTING SPRINT NEXTEL PANEL ANTENNAS (TOTAL 12) MOUNTED BEHIND EXISTING FRP SCREEN PAINTED & TEXTURED TO MATCH (E) BUILDING.
- PROPOSED SCREEN EXTENSION ALONG ALL SIDES OF ANTENNAS NO ELECTRICAL UPGRADES

OPERATING FREQUENCIES:
TRANSMIT: 850-845, 900-940, 1900-1915 MHz
RECEIVE: 850-824, 816-840, 1910-1925 MHz
ERP = 100 WATTS MAX.

CONSULTANT TEAM

ARCHITECTS:
MITCHELL J. ARCHITECTURE
4883 RONSON COURT, SUITE N
SAN DIEGO, CA 92111
TEL: (619) 650-3300
FAX: (619) 650-3440
CONTACT: ART BROWN (PROJECT MANAGER)

PLANNING:
DEPRATTI INC.
APPLICANT REPRESENTATIVE
CONTACT: BECKY SIKORSKI (619) 243-2900
SP441 - 2006000044@prattinc.com

LANDSCAPE ARCHITECT:
DARSONO DESIGN ASSOCIATES, INC.
304 MOUNT LA PLATA DRIVE
SAN DIEGO, CA 92117
TEL: (619) 541-2276
FAX: (619) 541-2028
CONTACT: DARSONO CLANNINGHAM

APPLICANT:
SPRINT NEXTEL
810 COMMERCE SUITE 200
IRVINE, CA 92612
CONTACT: STEPHEN DEHARS
DESK: 714-417-9342
MOBILE: 213-309-3428
POST OR AIR SUPPORT TEAM
TEL: (602) 650-4244
FAX: (480) 847-2276
PTN: (760) 250-8706
FAX: (602) 650-6202

SHEET INDEX

Sheet Number	Sheet Title
G-001	TITLE SHEET - PROJECT INFORMATION & VICINITY MAP
A-101	SITE PLAN & NOTES
A-201	EXTERIOR ELEVATIONS
A-401	PARTIAL ROOF PLAN
D-501	ANTENNA LAYOUT
D-502	ARCHITECTURAL DETAILS
LDPLD	LANDSCAPE PLAN

APPLICABLE CODES

PROJECT SUMMARY

CONSULTANT TEAM

SHEET INDEX

JUTLAND
SD54XC907
3219 CLAIREMONT MESA
SAN DIEGO CA 92177

architecture Mitchell J. Architecture

G-001

Project No: _____

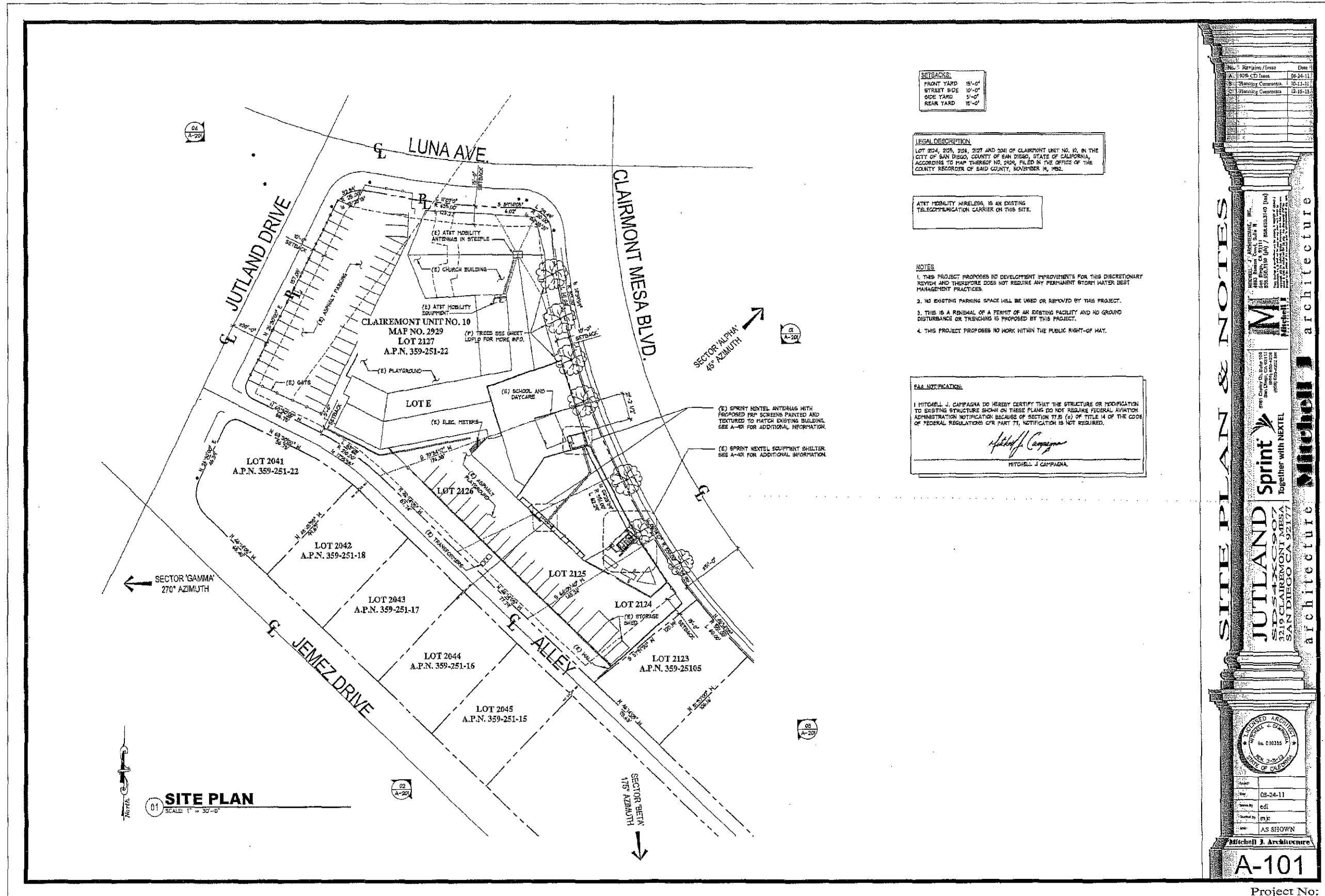

A-101

Project No:

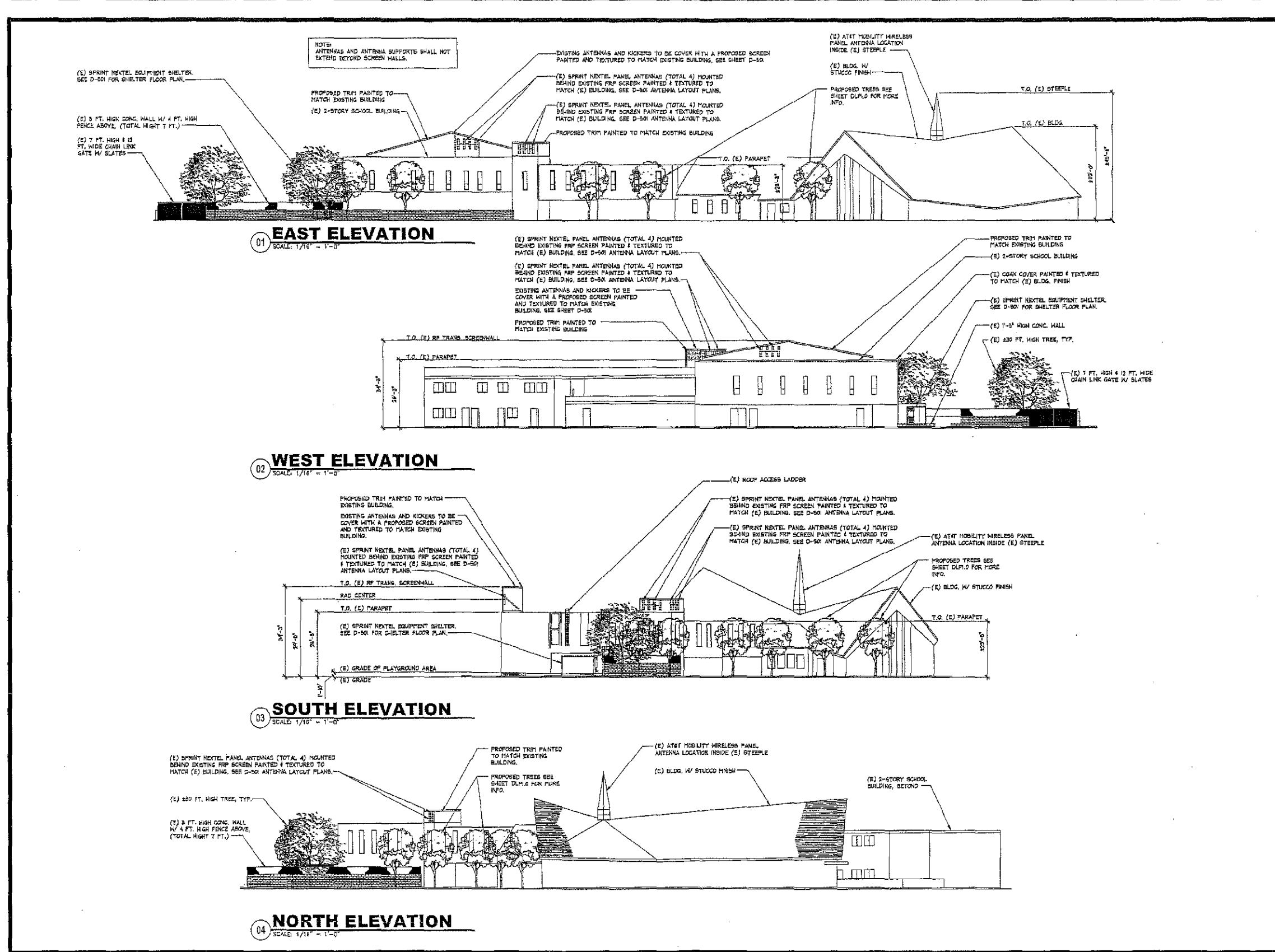

EXTERIOR ELEVATIONS

JUTLAND Sprint

3219 CLAREMONT MESA
SAN DIEGO CA 92177

architecture Mitchell J architecture

Revised/Name	Date
A. Site CD Issue	08-24-11
B. Planning Comments	10-11-11
C. Missing Comments	12-15-11

REGISTERED ARCHITECT
MICHAEL J. MITCHELL, INC.
2845 BARNES COURT, SUITE 200
SAN DIEGO, CA 92121 (619) 488-8824 (fax)
MICHAEL J. MITCHELL, INC.
2845 BARNES COURT, SUITE 200
SAN DIEGO, CA 92121 (619) 488-8824 (fax)

JUTLAND Sprint
3219 CLAREMONT MESA
SAN DIEGO CA 92177
Together with NEXTEL

AS SHOWN

A-201

Project No:

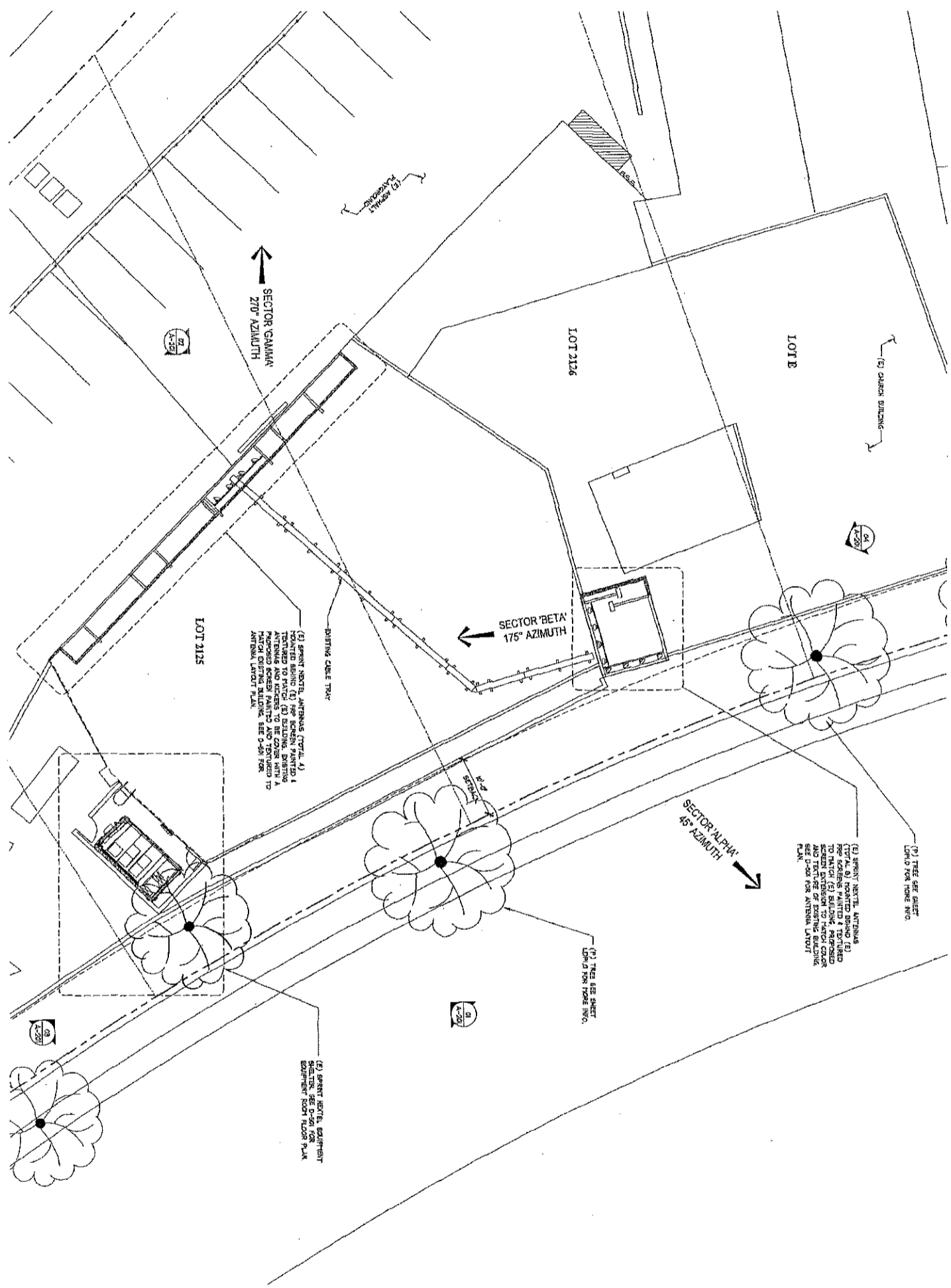

01 PARTIAL ROOF PLAN
SCALE: 1/8" = 1'-0"

PARTIAL ROOF PLAN

JUTLAND
SD54XC907
3219 CLAIREMONT MESA
SAN DIEGO CA 92177

Sprint
Together with NEXTEL

8781 County St. Suite 100
San Diego, CA 92121
(619) 650-4209
(619) 650-4202 fax

Mitchell J architecture
MITCHELL J. ARCHITECTURE, INC.
4883 Roman Court, Suite H
San Diego, CA 92117
858.650.3130 (ph) / 858.650.3140 (fax)

Revision	Date
01	08-24-11
02	10-11-11
03	11-16-11

A-401

Project No:

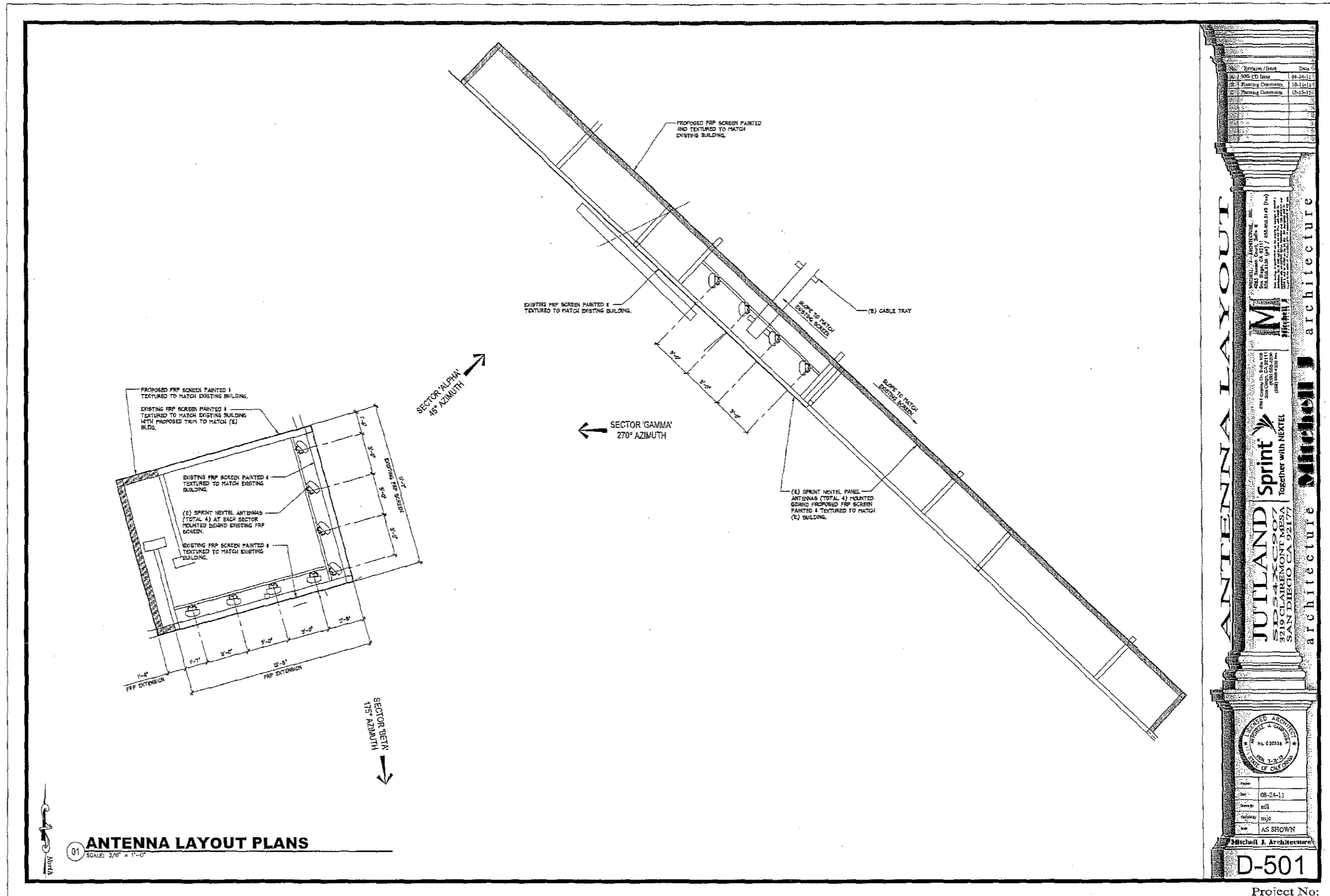

01 ANTENNA LAYOUT PLANS
SCALE: 3/8" = 1'-0"

Revision / Issue	Date
01	08-24-11
02	10-14-11
03	02-15-12

JUTLAND Sprint
SDS-4-KC-07
3219 CLAREMONT MEESA
SAN DIEGO CA 92177

MITCHELL J. ARCHITECTURE
architect

ANTENNA LAYOUT

Professional Engineer Seal: **MITCHELL J. ARCHITECTURE**, No. C120336, State of California, Expires 3-31-12.

AS SHOWN

D-501

Project No:

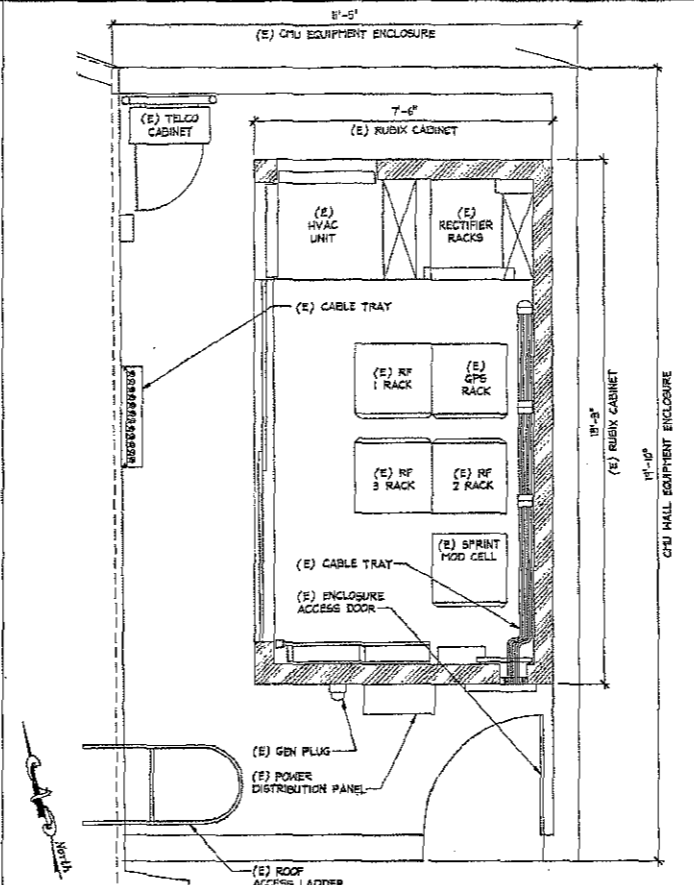

02 EQUIPMENT SHELTER PLAN
SCALE: 1/2" = 1'-0"

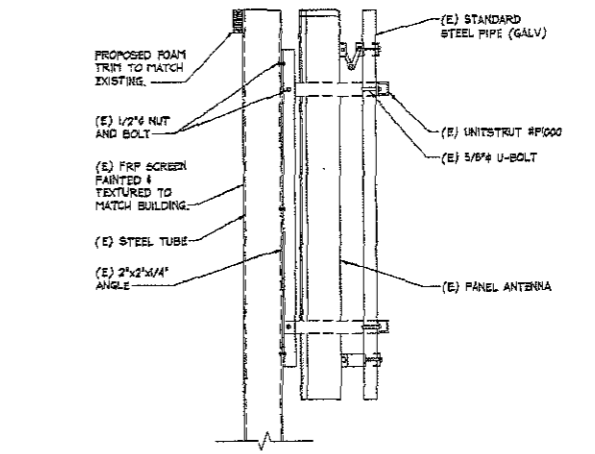

03 ANTENNA ATTACHMENT DETAIL
SCALE: 1" = 1'-0"

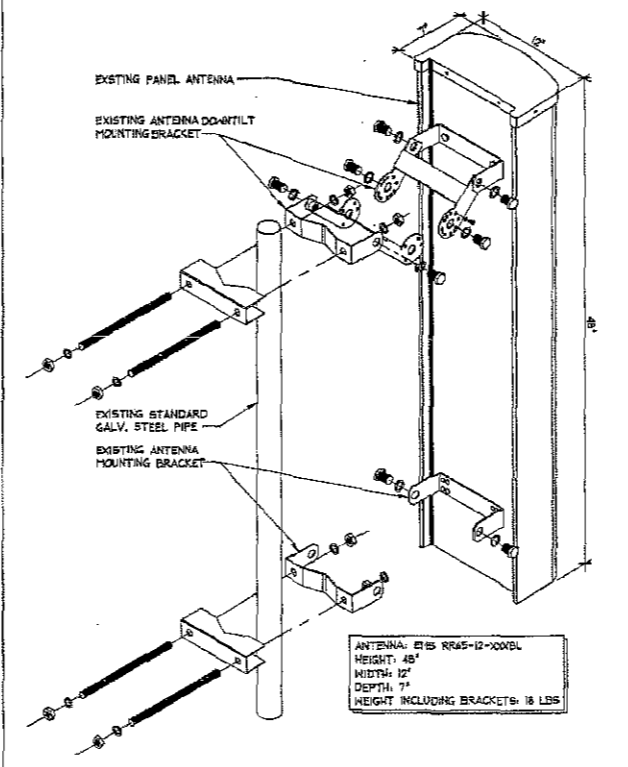

04 ANTENNA DETAIL
SCALE: 1" = 1'-0"

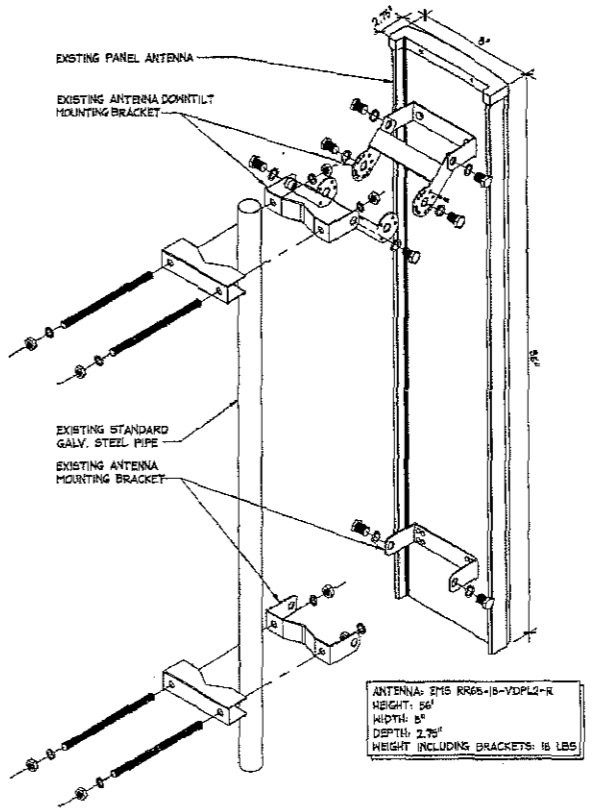

05 ANTENNA DETAIL
SCALE: 1" = 1'-0"

01 NOT USED
SCALE: NTS

Revision / Issue	Date
50% CD Issue	08-24-11
Planning Comments	10-11-11
Planning Comments	12-15-11

ARCHITECTURAL DETAILS
 JUTLAND Sprint Together with NEXTEL
 3219 CLAREMONT MESA, SAN DIEGO CA 92117
 MICHELL J. ARCHITECTURE, INC.
 4881 BURNING CREEK, SAN DIEGO CA 92121
 619.594.3300 (PH) / 619.594.3340 (FAX)
 MICHELL J. ARCHITECTURE, INC.
 ARCHITECTURE

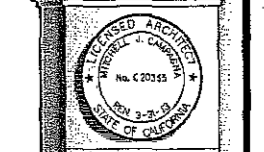

Project	
Date	08-24-11
Drawn By	edl
Checked By	mjc
Scale	AS SHOWN

Mitchell J. Architecture
D-502

Project No:

PLANTING SPECIFICATIONS:

- ALL PLANTING MATERIALS AND PROCEDURES SHALL CONFORM TO THE CITY OF SAN DIEGO SPECIFICATIONS AND REQUIREMENTS.
- PRIOR TO PLANTING, THE IRRIGATION SYSTEM SHALL BE FULLY OPERATIONAL.
- LANDSCAPE CONTRACTOR SHALL RAKE AND FINE GRADE ALL AREAS TO BE PLANTED PRIOR TO THE COMMENCEMENT OF PLANTING OPERATIONS. LANDSCAPE CONTRACTOR IS RESPONSIBLE FOR THE FINISH GRADING OF THE SITE. SITE SHALL BE RECEIVED AT PLUS OR MINUS ONE (1) INCH.
- FOR EACH CUBIC YARD OF BACKFILL CONSISTING OF 60% LEACHED ON-SITE SOIL AND 40% NITROGEN STABILIZED WOOD SHAVINGS, THE FOLLOWING AMENDMENTS SHALL BE INCORPORATED:
 - 1 LB. AGRIFORM SLOW RELEASE FERTILIZER 12-12-12
 - 2 LBS. IRON SULFATE (DO NOT PLACE ON CONCRETE SURFACES)
 - 1 LB. SOIL SULPHUR
- PLANTING TABLETS 20-10-5
 2-21 GRAM TABLETS PER 1 GALLON CONTAINER
 3-21 GRAM TABLETS PER 5 GALLON CONTAINER
 4-21 GRAM TABLETS PER 15 GALLON CONTAINER
 1-21 GRAM TABLET PER 4" OF BOX SIZE
- ALL TREES SHALL BE PLANTED OUTSIDE THE PUBLIC RIGHT-OF-WAY UNDER THE FOLLOWING CONDITIONS:
 - 10'-0" AWAY FROM TRAFFIC SIGNS (STOP SIGNS)
 - 5'-0" AWAY FROM UNDERGROUND UTILITY LINES
 - 10'-0" AWAY FROM ABOVE GROUND UTILITY STRUCTURES
 - 10'-0" AWAY FROM DRIVEWAYS (ENTRIES)
 - 25'-0" AWAY FROM INTERSECTIONS (INTERSECTING CURB LINES OF TWO STREETS)
 SHOULD IT BE NECESSARY TO PLANT WITHIN 10'-0" OF HARDSCAPE, WALLS AND/OR STRUCTURES, A ROOT CONTROL BARRIER SHALL BE UTILIZED. BARRIER SHALL EXTEND ALONG THE EDGE OF THE HARDSCAPE, WALL AND/OR STRUCTURE BEING PROTECTED TO THE EXTENT OF THE MAJURE DRIP LINE OF THE TREE (MINIMUM 10'-0").
- PLANT PITS SHALL BE SQUARE AND TWO (2) TIMES GREATER IN DIAMETER THAN THE PLANT CONTAINER AND AT LEAST TWELVE (12) INCHES BELOW THE BOTTOM OF THE CONTAINER.
- ALL WATERING BASINS SHALL RECEIVE A MINIMUM OF THREE (3) INCHES OF SHREDDED BARK MULCH. A ONE (1) CUBIC YARD SAMPLE OF MULCH TO BE USED SHALL BE DELIVERED TO THE SITE FOR INSPECTION BY THE OWNER/LANDSCAPE ARCHITECT.
- THE LANDSCAPE CONTRACTOR SHALL LEAVE THE SITE IN A CLEAN CONDITION REMOVING ALL USED MATERIALS, TRASH, AND TOOLS ON A DAILY BASIS.
- LANDSCAPE CONTRACTOR SHALL MAINTAIN ALL TREE PLANTING FOR A PERIOD OF 1 YEARS.

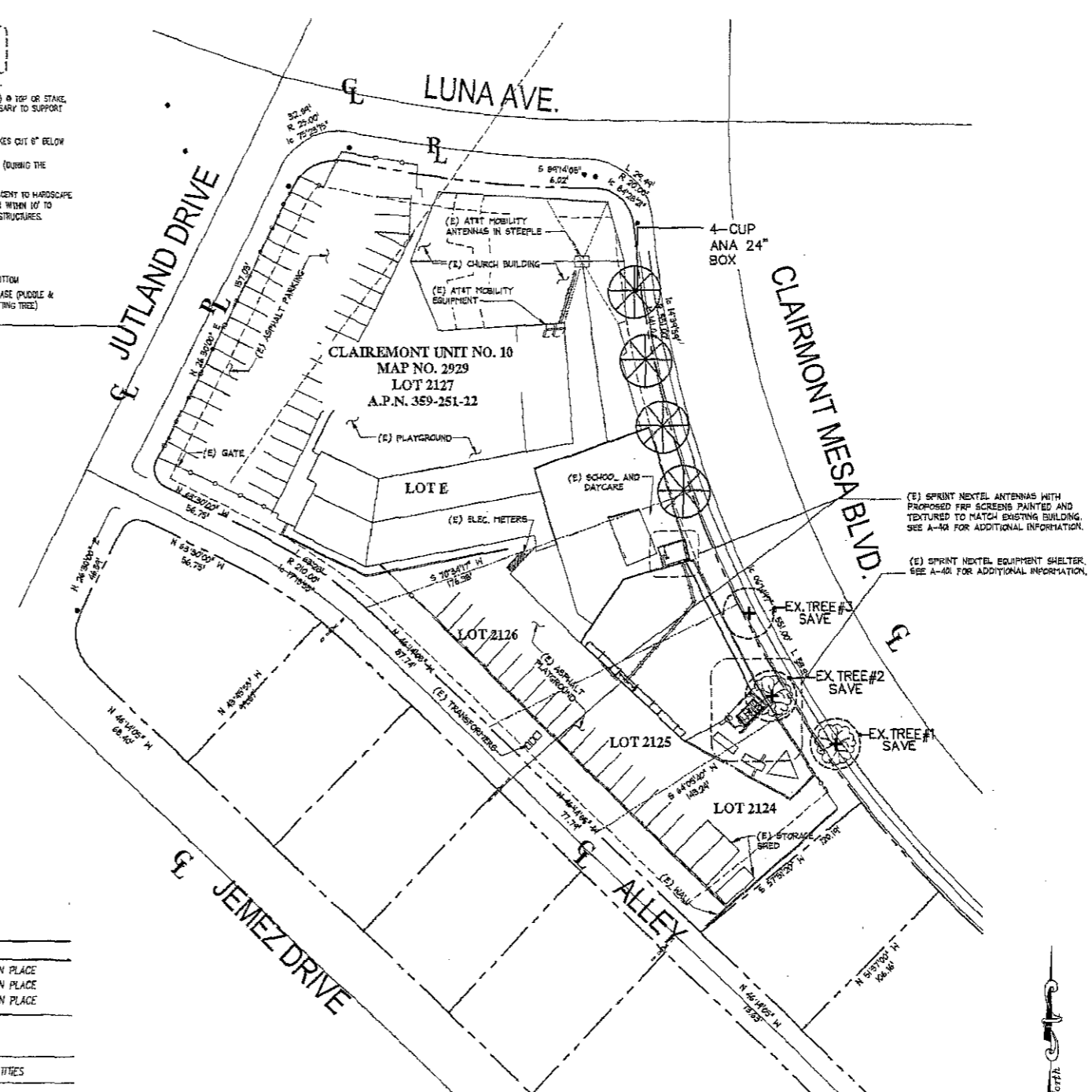
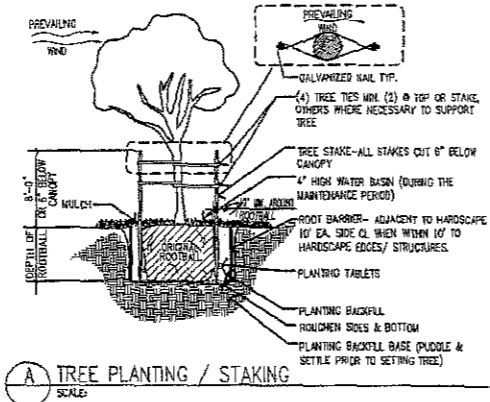

EXISTING LANDSCAPE LEGEND:

SYMBOL	BOTANICAL NAME	COMMON NAME	SIZE/HEIGHTS X SPREAD/CA (CALIPER)	REMARKS
EX. TREE #1	CUPANOPSIS ANACARDIODES	CARROTWOOD TREE	25\"/>	

PLANTING LEGEND:

SYMBOL	BOTANICAL NAME	COMMON NAME	SIZE/HEIGHTS X SPREAD	REMARKS	G. SYMBOL	QUANTITIES
CLIP ANA	CUPANOPSIS ANACARDIODES	CARROTWOOD TREE	24\"/>			

3\"/>

01 Landscape Development Plan
 SCALE: 1/32\"/>

LANDSCAPE DEVELOPMENT PLAN
JUTLAND Sprint
 5125 JUTLAND DRIVE
 SAN DIEGO, CA 92117
 619-444-0907
 TOGETHER WITH NEXTEL
Mitchell J. Architecture
 3219 CLAIMONT MESA
 SAN DIEGO, CA 92117
 619-584-1227
LDP1.0
 Project No:

Rev.	Revision / Issue	Date
A	90% CD Issue	08-24-11
B	Planning Comments	10-11-11
C	Planning Comments	11-15-11

LICENSED ARCHITECT
 MICHELL J. ARCHITECTURE, INC.
 4883 REMON COURT, SUITE N
 SAN DIEGO, CA 92117
 (619) 584-1227
 (619) 584-1228
 (619) 584-1229
 (619) 584-1230
 (619) 584-1231
 (619) 584-1232
 (619) 584-1233
 (619) 584-1234
 (619) 584-1235
 (619) 584-1236
 (619) 584-1237
 (619) 584-1238
 (619) 584-1239
 (619) 584-1240
 (619) 584-1241
 (619) 584-1242
 (619) 584-1243
 (619) 584-1244
 (619) 584-1245
 (619) 584-1246
 (619) 584-1247
 (619) 584-1248
 (619) 584-1249
 (619) 584-1250
 (619) 584-1251
 (619) 584-1252
 (619) 584-1253
 (619) 584-1254
 (619) 584-1255
 (619) 584-1256
 (619) 584-1257
 (619) 584-1258
 (619) 584-1259
 (619) 584-1260
 (619) 584-1261
 (619) 584-1262
 (619) 584-1263
 (619) 584-1264
 (619) 584-1265
 (619) 584-1266
 (619) 584-1267
 (619) 584-1268
 (619) 584-1269
 (619) 584-1270
 (619) 584-1271
 (619) 584-1272
 (619) 584-1273
 (619) 584-1274
 (619) 584-1275
 (619) 584-1276
 (619) 584-1277
 (619) 584-1278
 (619) 584-1279
 (619) 584-1280
 (619) 584-1281
 (619) 584-1282
 (619) 584-1283
 (619) 584-1284
 (619) 584-1285
 (619) 584-1286
 (619) 584-1287
 (619) 584-1288
 (619) 584-1289
 (619) 584-1290
 (619) 584-1291
 (619) 584-1292
 (619) 584-1293
 (619) 584-1294
 (619) 584-1295
 (619) 584-1296
 (619) 584-1297
 (619) 584-1298
 (619) 584-1299
 (619) 584-1300

From: Debra DePratti Gardner [ddgardner@cox.net]
Sent: Wednesday, November 16, 2011 9:02 AM
To: Hempton, Alexander; 'Paul Hokeness'; 'Caitlyn Kes'
Subject: RE: 255594 - Sprint Nextel Jutland, Completeness Review SD54XC907

Alex-Last night, the CPG approved unanimously the project as resubmitted to you.

Thank you,

Debra DePratti Gardner
DePratti Incorporated
619-726-8110



 City of San Diego
 Development Services
 1222 First Ave., MS-302
 San Diego, CA 92101
 (619) 446-6000

Ownership Disclosure Statement

Approval Type: Check appropriate box for type of approval (s) requested:
 Neighborhood Use Permit
 Coastal Development Permit
 Neighborhood Development Permit
 Site Development Permit
 Planned Development Permit
 Conditional Use Permit
 Variance
 Tentative Map
 Vesting Tentative Map
 Map Waiver
 Land Use Plan Amendment
 Other

Project Title: SPRINT JUTLAND
Project No. For City Use Only: 255594

Project Address: 3219 CLAIEMONT MESA BLVD, SAN DIEGO, CA 92117

Part 1 - To be completed when property is held by individual(s)

By signing the Ownership Disclosure Statement, the owner(s) acknowledge that an application for a permit, map or other matter, as identified above, will be filed with the City of San Diego on the subject property, with the intent to record an encumbrance against the property. Please list below the owner(s) and tenant(s) (if applicable) of the above referenced property. The list must include the names and addresses of all persons who have an interest in the property, recorded or otherwise, and state the type of property interest (e.g., tenants who will benefit from the permit, all individuals who own the property). A signature is required of at least one of the property owners. Attach additional pages if needed. A signature from the Assistant Executive Director of the San Diego Redevelopment Agency shall be required for all project parcels for which a Disposition and Development Agreement (DDA) has been approved / executed by the City Council. Note: The applicant is responsible for notifying the Project Manager of any changes in ownership during the time the application is being processed or considered. Changes in ownership are to be given to the Project Manager at least thirty days prior to any public hearing on the subject property. Failure to provide accurate and current ownership information could result in a delay in the hearing process.

Additional pages attached Yes No

Name of Individual (type or print): <input type="checkbox"/> Owner <input type="checkbox"/> Tenant/Lessee <input type="checkbox"/> Redevelopment Agency Street Address: City/State/Zip: Phone No: _____ Fax No: _____ Signature: _____ Date: _____	Name of Individual (type or print): <input type="checkbox"/> Owner <input type="checkbox"/> Tenant/Lessee <input type="checkbox"/> Redevelopment Agency Street Address: City/State/Zip: Phone No: _____ Fax No: _____ Signature: _____ Date: _____
Name of Individual (type or print): <input type="checkbox"/> Owner <input type="checkbox"/> Tenant/Lessee <input type="checkbox"/> Redevelopment Agency Street Address: City/State/Zip: Phone No: _____ Fax No: _____ Signature: _____ Date: _____	Name of Individual (type or print): <input type="checkbox"/> Owner <input type="checkbox"/> Tenant/Lessee <input type="checkbox"/> Redevelopment Agency Street Address: City/State/Zip: Phone No: _____ Fax No: _____ Signature: _____ Date: _____

Printed on recycled paper. Visit our web site at www.sandiego.gov/development-services
 Upon request, this information is available in alternative formats for persons with disabilities.

DS-318 (5-05)

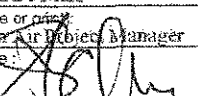
Project Title:	Project No. (For City Use Only) <u>255594</u>
Part II - To be completed when property is held by a corporation or partnership	
Legal Status (please check):	
<input checked="checked" type="checkbox"/> Corporation <input type="checkbox"/> Limited Liability (or- <input type="checkbox"/> General) What State? <u>KS</u> Corporate Identification No. _____ <input type="checkbox"/> Partnership	
<p>By signing the Ownership Disclosure Statement, the owner(s) acknowledge that an application for a permit, map or other matter, as identified above, will be filed with the City of San Diego on the subject property with the intent to record an encumbrance against the property. Please list below the names, titles and addresses of all persons who have an interest in the property, recorded or otherwise, and state the type of property interest (e.g., tenants who will benefit from the permit, all corporate officers, and all partners in a partnership who own the property). A signature is required of at least one of the corporate officers or partners who own the property. Attach additional pages if needed. Note: The applicant is responsible for notifying the Project Manager of any changes in ownership during the time the application is being processed or considered. Changes in ownership are to be given to the Project Manager at least thirty days prior to any public hearing on the subject property. Failure to provide accurate and current ownership information could result in a delay in the hearing process. Additional pages attached <input type="checkbox"/> Yes <input checked="checked" type="checkbox"/> No</p>	
Corporate/Partnership Name (type or print): <u>Sprint PCS</u>	Corporate/Partnership Name (type or print):
<input type="checkbox"/> Owner <input checked="checked" type="checkbox"/> Tenant/Lessee	<input type="checkbox"/> Owner <input type="checkbox"/> Tenant/Lessee
Street Address: <u>8323 Rucille Court</u>	Street Address:
City/State/Zip: <u>Santee / CA / 92071</u>	City/State/Zip:
Phone No: Fax No: <u>(858) 3650-4249 619 847-2275</u>	Phone No: Fax No:
Name of Corporate Officer/Partner (type or print): <u>Stephen De Mars</u>	Name of Corporate Officer/Partner (type or print):
Title (type or print): <u>Post Office Air Traffic Manager</u>	Title (type or print):
Signature:  Date: <u>Jun 9, 2011</u>	Signature : Date:
Corporate/Partnership Name (type or print):	Corporate/Partnership Name (type or print):
<input type="checkbox"/> Owner <input type="checkbox"/> Tenant/Lessee	<input type="checkbox"/> Owner <input type="checkbox"/> Tenant/Lessee
Street Address:	Street Address:
City/State/Zip:	City/State/Zip:
Phone No: Fax No:	Phone No: Fax No:
Name of Corporate Officer/Partner (type or print):	Name of Corporate Officer/Partner (type or print):
Title (type or print):	Title (type or print):
Signature : Date:	Signature : Date:
Corporate/Partnership Name (type or print):	Corporate/Partnership Name (type or print):
<input type="checkbox"/> Owner <input type="checkbox"/> Tenant/Lessee	<input type="checkbox"/> Owner <input type="checkbox"/> Tenant/Lessee
Street Address:	Street Address:
City/State/Zip:	City/State/Zip:
Phone No: Fax No:	Phone No: Fax No:
Name of Corporate Officer/Partner (type or print):	Name of Corporate Officer/Partner (type or print):
Title (type or print):	Title (type or print):
Signature : Date:	Signature : Date:



Sprint – Network Supplier Performance Management

Mailstop: KSOPHD0204 - 2D579
6220 Sprint Parkway
Overland Park, KS 66251

RE: Sprint Ericsson Management Association

To Whom It May Concern:

In September of 2009 Sprint Nextel (Sprint) entered into a contractual arrangement with Ericsson Services, Inc (Ericsson) to perform certain management functions pertaining to the acquisition of new sites and installation of new facilities for its wireless telecommunications network. Pursuant to that agreement, Sprint has authorized Ericsson's site development managers to act as a representative of Sprint in the performance of all field activities in this regard, including the authority sign site lease agreements, amendments and other documents necessary to complete these real estate development projects.

Please be advised that Ericsson has contractually agreed to adhere to all the applicable Sprint and customer security policies and confidentiality commitments, and that Ericsson is committed to, and maintains high confidentiality standards of its own. We can, therefore, assure you that the services provided in these matters will be delivered with the same level of care and professionalism as though Sprint were performing these functions through its own employees.

Thank you very much for your acceptance of Sprint's representative, Ericsson Services Inc.

Sincerely,

A handwritten signature in cursive script that reads "John Harrison".

on behalf of
John Harrison, Vice President
Network Performance Management

Executive Team

- [Welcome](#)
- [Executive Team](#)
- [Corporate Governance](#)
- [Corporate Social Responsibility](#)
- [Inclusion & Diversity](#)
- [Partnerships](#)
- [History](#)
- [Awards & Recognition](#)
- [Sprint Experience](#)



Dan Hesse
 Chief Executive Officer
 Sprint Nextel Corporation
[Recent Speeches](#)



Joseph J. Eutenauer
 Chief Financial Officer



Danny Bowman
 President, Integrated Solutions Group



Paget L. Alves
 President, Business Markets Group



Matt Carter
 President, Global Wholesale Solutions



Keith Cowan
 President, Strategy and Corporate Initiatives



Steve Elfman
 President, Network Operations and Wholesale



Bob Johnson
 Chief Service Officer



Robert H. Johnson
President, Consumer Business Unit



William Morgan
Senior Vice President, Corporate Marketing



Sandra J. Price
Senior Vice President, Human Resources



Bill White
Senior Vice President, Corporate Communications and Corporate Social Responsibility



Charles Wunsch
General Counsel and Corporate Secretary

articles 1

Project Chronology

Sprint Nextel Jutland – Project No. 255594

Date	Action	Description	City Review Time	Applicant Response Time
10/19/2011	First Submittal	Project Deemed Complete		
12/2/2011	First Assessment Letter		44	
12/22/2011	Second Submittal			20
5/3/2012	Public Hearing – Planning Commission		133	
TOTAL STAFF TIME			177	
TOTAL APPLICANT TIME				20
TOTAL PROJECT RUNNING TIME		From Deemed Complete to Planning Commission Hearing	197 (in calendar days)	

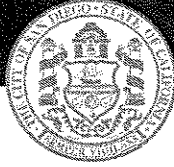

THE CITY OF SAN DIEGO

DATE OF NOTICE: April 19, 2012

NOTICE OF PUBLIC HEARING PLANNING COMMISSION RECOMMENDATION

DATE OF HEARING: May 3, 2012
TIME OF HEARING: 9:00 AM
LOCATION OF HEARING: Council Chambers, 12th Floor, City Administration Building,
202 C Street, San Diego, California

PROJECT TYPE: CONDITIONAL USE PERMIT, PLANNED DEVELOPMENT
PERMIT, and SITE DEVELOPMENT PERMIT, PROCESS 5
PROJECT NUMBER: 255594
PROJECT NAME: SPRINT NEXTEL JUTLAND
APPLICANT: DEBRA DEPRATTI, DEPRATTI, INC., AGENTS
REPRESENTING SPRINT NEXTEL

COMMUNITY PLAN AREA: Clairemont Mesa

COUNCIL DISTRICT: District 6

CITY PROJECT MANAGER: Alex Hempton, Associate Planner
PHONE NUMBER/E-MAIL: (619) 446-5349 / ahempton@sandiego.gov

As a property owner, tenant or person who has requested notice, you should know that the Planning Commission will hold a public hearing to **recommend** approval, conditional approval, or denial to the City Council of a Conditional Use Permit (CUP), Planned Development Permit (PDP), and Site Development Permit (SDP) for a Wireless Communication Facility (WCF) that exceeds the Clairemont Mesa Height Limit Overlay Zone. The project consists of panel antennas mounted behind radio-frequency transparent screening on an existing building and is located at 3219 Clairemont Mesa Boulevard.

The decision to approve, conditionally approve, modify or deny the Conditional Use Permit (CUP), Planned Development Permit (PDP), and Site Development Permit (SDP) for a Wireless Communication Facility (WCF) will be made by the City Council at a future public hearing. You will also receive a notice of the City Council public hearing.

If you have any questions after reviewing this information, you can contact the City Project Manager listed above.

This information will be made available in alternative formats upon request. To request an agenda in alternative format or to request a sign language or oral interpreter for the meeting, call Support Services at (619) 321-3208 at least five working days prior to the meeting to insure availability. Assistive Listening Devices (ALD's) are also available for the meeting upon request.

Internal Order Number: 24002125

Revised 04/08/10 HMD
document1

SD54XC907 Jutland Photo Survey Key Map



SD54XC907 Jutland Photo Survey



1. View looking south at North Elevation .
2. View looking west at East Elevation .



SD54XC907 Jutland Photo Survey



- 3. View looking north at South Elevation .
- 4. View looking east at West Elevation.



SD54XC907 Jutland Photo Survey

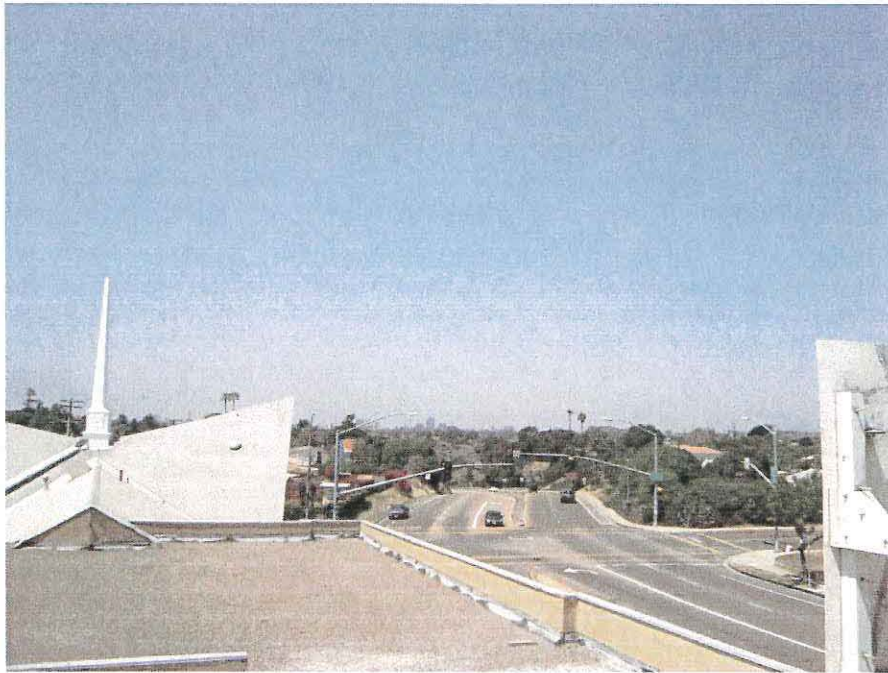

- 5. View looking north from site.
- 6. View looking east from site.



SD54XC907 Jutland Photo Survey

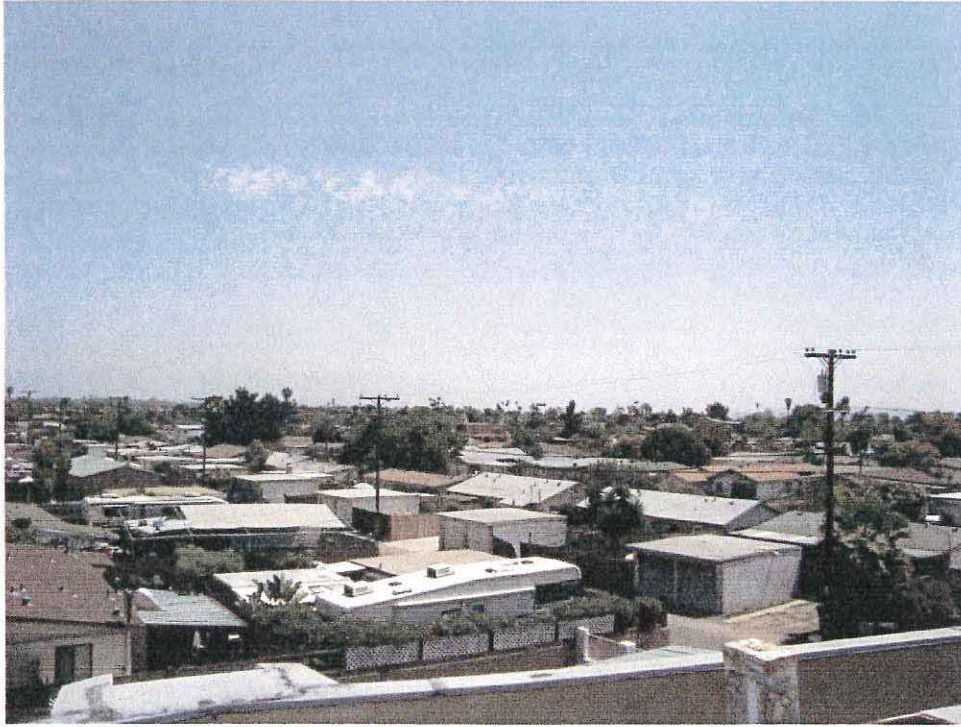

7. View looking south from site.
8. View looking west from site.



SD54XC907 Jutland Photo Survey
Near View of EQ Area

