



THE CITY OF SAN DIEGO

REPORT TO THE PLANNING COMMISSION

DATE ISSUED: November 29, 2012 **REPORT NO.** PC-12-109
ATTENTION: Planning Commission, Agenda of December 13, 2012
SUBJECT: OCEAN VIEW CHURCH - PROJECT NO. 205163- PROCESS FOUR
OWNER: Midway Baptist Church (Attachment 10)
APPLICANT: John Pyjar, Domus Studio Architecture

SUMMARY

Issues: Should the Planning Commission approve an expansion of an existing church and school with deviations, located at 2450 and 2460 Palm Avenue in the Otay Mesa-Nestor Community Plan area?

Staff Recommendation:

1. **Adopt** Mitigated Negative Declaration, Project No. 205163, and **Adopt** the Mitigation, Monitoring and Reporting Program; and
2. **Approve** Planned Development Permit No. 727817 and Conditional Use Permit No. 727818 (Amendment to Conditional Use Permit No. 13107).

Community Planning Group Recommendation: At the May 11, 2011, meeting, the Otay Mesa-Nestor Planning Group voted 11-0-0 to recommend approval of the proposed project as submitted with no recommendations.

Environmental Review: Mitigated Negative Declaration, Project No. 205163, has been prepared for the project in accordance with the State of California Environmental Quality Act (CEQA) Guidelines. A Mitigation, Monitoring and Reporting Program has been prepared which will reduce, to below a level of significance potential impacts identified in the environmental review process.



Fiscal Impact Statement: None with this action; the costs of processing this project have been paid by the applicant through a deposit account.

Code Enforcement Impact: None with this action.

Housing Impact Statement: The proposed project does not propose any residential units and therefore would not result in an increase or decrease in existing or potential housing units.

BACKGROUND

Existing Conditions

The 12.53-acre site is located at 2450 and 2460 Palm Avenue (Attachment 3) in the RS-1-7 and RS-1-2 Zones, the Transit Area Overlay Zone, the Residential Tandem Parking Overlay Zone, the Airport Influence Area, and the Federal Aviation Administration (FAA) Part 77 Notification Area, within the Palm City area of the Otay Mesa-Nestor Community Plan (Attachment 2). There is single-family residential development to the east, west and south, with a portion of the Otay Valley Regional Park to the north. Conditional Use Permit (CUP) No. 13107 (Attachment 7) was issued on August 15, 1975, to construct the existing church with parking and accessory facilities. The property has been under the ownership of the church since 1976.

The project site encompasses three parcels (Attachment 1): Parcel One (3.0-acres) in the northeastern portion of the site includes the church parsonage, 25 surface parking spaces and two storage buildings; Parcel Two (8.5-acres) fronts Palm Avenue and includes a gymnasium, two administrative buildings, classrooms, a sanctuary, meeting rooms, outdoor play areas, a temporary tent structure, 304 surface parking spaces and an athletic field; and Parcel Three (1.03-acres) is a panhandle lot in the northwestern portion of the site and also fronts Palm Ave. It includes a gazebo, a concession building, administrative offices and 20 surface parking spaces. Parcel one is within the RS-1-2 Zone; Parcels Two and Three are within the RS-1-7 Zone. The total square footage for all buildings on all parcels is approximately 68,000 square feet with a floor area ratio of 0.12.

The Otay Mesa-Nestor Community Plan designates the project site as Very Low Density Residential (0-5 dwelling units per net acre). The Community Plan does not specifically discuss religious facilities or church uses within residential zones. However the existing church facility pre-dates the adoption of the Otay Mesa Community Plan in 1979. Additionally, churches are typically allowed city-wide in residential zones with a Conditional Use Permit.

DISCUSSION

Project Description:

The project proposes a phased development plan for the expansion of the existing church and school uses. The project is proposed in five phases with a total gross floor area of approximately

135,000 square feet and a floor area ratio of 0.25. Demolition, remodeling and new construction is proposed to provide a cohesive campus design for all structures. New construction includes a youth ministry building, a Fellowship Hall/Chapel, pre-school, multi-purpose building, weight room/lockers, day camp storage, a garage, and a multi-use building. There is also the construction of a two-level 13,825-square-foot above grade parking structure and remodeling of the existing multi-purpose sports field including new bleachers and lighting for the field. The project proposes to increase enrollment in pre-school with a maximum enrollment of 120 children and a maximum enrollment of 534 children for kindergarten through 12th grade.

The existing buildings would be remodeled to match the proposed buildings which consist of stucco, wood, and metal with storefront windows, roofs and metal canopies painted in earth tone colors. This will bring cohesiveness to the existing hodgepodge design and placement of the various existing buildings.

The site is accessed by three driveways on Palm Avenue. The easternmost driveway provides access to the back parcel which leads to a surface parking lot, multi-use building and the garage maintenance building. The driveway to the west provides circulation to the entrance of the campus. The westernmost driveway would access the proposed above grade parking garage and the front entrance of the campus. Staff has reviewed the phasing and conditions are provided to ensure there is the required amount of parking for each phase. A minimum of 272 automobile spaces (including 6 standard accessible spaces and 1 van accessible space), 5 motorcycle spaces, and 5 bicycle spaces with racks are required by the Land Development Code. By the end of the final phase, the applicant proposes a total of 425 automobile spaces (including 10 standard accessible spaces and 2 van accessible spaces), 7 motorcycle spaces, and 7 bicycle spaces.

The project complies with the Federal Aviation Administration Part 77 Noticing Area (NOLF Imperial Beach) and the Airport Influence Area (Brown Field). The Federal Aviation Administration (FAA) conducted an aeronautical study for the project and determined the building's maximum height of 59 feet (for the Church tower) will not cause aeronautical hazards to air space as regulated by the FAA and Brown Field and the San Diego County Regional Airport Authority land use regulations.

Required Permits

The proposed development requires a Process Four Planned Development Permit (PDP) to allow deviations for height, setbacks, signage and retaining walls (as further described below) per San Diego Municipal Code (SDMC) Section 126.0602(b)(1); Conditional Use Permit (CUP) No. 13107 (Attachment 7) was issued on August 15, 1975 to construct the existing church with parking and accessory facilities. The project requires an amendment to Conditional Use Permit (CUP) No. 13107 for the proposed expansion of the church, school facilities and child care uses within a residential zone per SDMC Section 126.0303.

A decision on a Process Four PDP and CUP shall be made by the Planning Commission as the decision maker. The decision may be appealed to the City Council in accordance with SDMC Section 112.0508.

Planned Development Permit:

A Planned Development Permit (PDP) per SDMC Section 126.0602(b)(1) is required to allow for the deviations listed below, all of which are supported by staff. The deviations are summarized as follows:

- a. A deviation to allow a maximum height of 43'-3" for the proposed Fellowship Hall/Chapel, where a maximum of 30'-0" is permitted.
- b. A deviation to allow the maximum heights of 58'-8" and 51'-3" for the proposed church tower and spire, where a maximum of 30'-0" is permitted.
- c. A deviation to allow a maximum height of 31'-6" for the proposed multi-purpose building, where a maximum of 30'-0" is permitted.
- d. A deviation to allow a maximum height of 40'-11" for the proposed parking structure, where a maximum of 30'-0" is permitted.
- e. A deviation to allow encroachments into the required side yard setbacks for the proposed improvements to the existing sports field including, but not limited to, dugouts, fencing and lighting.
- f. A deviation to allow a side yard setback of 15'-0" for the proposed trash enclosure, where 26'-6" is the minimum required.
- g. A deviation to allow a side yard setback of 33'-3" for the proposed parking structure, where 56'-0" is the minimum required.
- h. A deviation to allow three retaining walls within the side yard setback where two are permitted; and a deviation to allow a 4-foot separation between two of the retaining walls in the side yard setback, where 6 feet is required.
- i. A deviation to allow the construction of two monument ground signs where none are permitted in a residential zone.

Height Deviations (a-d): The underlying RS-1-7 and RS-1-2 zones both limit height to a maximum of 30 feet, which is consistent with lower density residential development. The current Ocean View Church campus contains six existing non-residential structures that were separately constructed over a period of 35 years, and employ a variety of designs, architectural styles, and structure heights varying from 15 feet to 48 feet in height. Prior to 2000, deviations were allowed with the approval of a CUP, as was the case with the existing church towers built in 1977 at 48 feet. Any existing structures that deviate are not required to be identified as a deviation in a new permit.

The proposed project's goal is to provide a more cohesive, organized and interconnected design that will unite the older existing buildings with the new proposed parking structure, multi-purpose building, and Fellowship Hall/Chapel. The proposed site design would create a cohesive campus environment with a central courtyard to provide a direct and clear focal point and connection for the students. The proposed deviations to allow buildings taller than the zone allows (30-feet) is essential and fundamental to the goal of providing a more consistent, cohesive, and interconnected campus design.

The church tower marks the entry to the main doors of the lobby into the Sanctuary. The glass and steel tower is square at nine feet by nine feet and tapers to six feet by six feet at a height of 52 feet, which is the height of the tower roof. Above 52 feet a steel cross extends another 6'-8" for a maximum height of 58'-8" above the adjacent grade. At the Northwest corner of the Fellowship/Chapel building, a steel cross is attached to the building that extends 10 feet above the roof of the building for a maximum height of 51'-3". The steel cross measures 24 feet total in height and six feet in width. The cross is angled toward the playing field which creates a visual connection for participants and visitors. The deviations for the church tower and spire allow for a visual icon and landmark for the existing church. Staff has determined all deviations for the increased height are consistent with the purpose and intent of the regulation, would allow for a more functional project and would not adversely affect the surrounding community.

Setback Deviations (e-g): The deviations related to encroachments within the setbacks are for a new trash enclosure, parking structure, and improvements to the athletic fields. The calculation for the side yard setbacks are determined by the lot width. Due to the large size of the lots relative to the surrounding lots and split zoning, each parcel results in sizeable side yard setback requirements. The project's off-setting planes, building material and landscaping provide articulation that reduces the apparent bulk and scale of the structures. Staff has analyzed the deviations to setbacks and concluded there is still adequate distance within the setback to meet the intent of the regulations to provide free flow of light and air, and adequate separation from adjacent development.

The deviation for the placement of the dugouts, fencing and lighting for the athletic field within the side yard setback allows for flexibility during construction. The light pole at the northwest corner would be a minimum of four feet from the property line. The other light pole at the western property would be a minimum of 11 feet from the property line.

Retaining Wall Deviations (h): The proposed project requests a deviation to allow three retaining walls within the side yard setback where two are allowed, and a deviation to allow a four-foot separation between two of the retaining walls in the side yard where six feet is required. In order to align the parking structure with the rest of the campus, the proposed grade would increase approximately 17 feet. The western edge of the parking structure requires three retaining walls in order to accommodate this change in existing grade. Staff determined this deviation is minor and would allow for a more functional project and would not adversely affect the surrounding community.

Signage Deviation (i): The church has been in operation since 1976 and signage currently exists to direct congregants and staff to the site. The project proposes two monument ground signs. The

increase in signage proposed provides for the continued operation and function of a church. The signs have been reviewed for consistency with size and location requirements of the underlying zone, and have been determined to be appropriate for this use.

Environmental Analysis:

A Mitigated Negative Declaration (MND) was prepared in accordance with the State of California Environmental Quality Act (CEQA) Guidelines. The proposed project includes mitigation measures to offset potential impacts to Biological Resources (Land Use/MSCP) and Paleontology. Implementation of the Mitigation, Monitoring and Reporting Program would reduce these potential impacts to below a level of significance.

Conclusion:

Staff has reviewed the application for the Planned Development Permit and Conditional Use Permit and determined the project, except for the proposed deviation, would comply with the applicable sections of the Municipal Code. Staff believes the requested deviations are minor in scope and the proposed modifications provide for a more attractive, functional and efficient design than would be achieved through the strict application of the development regulations. Staff has determined the required findings would support the decision to approve the proposed project (Attachment 6). Therefore, staff recommends the Planning Commission approve the Planned Development Permit and Conditional Use Permit as conditioned.

ALTERNATIVES

1. **Approve** Planned Development Permit No. 727817 and Conditional Use Permit No. 727818, (Amendment to Conditional Use Permit No. 13107), **with modifications.**
2. **Deny** Planned Development Permit No. 727817 and Conditional Use Permit No. 727818, (Amendment to Conditional Use Permit No. 13107), **if the findings required to approve the project cannot be affirmed.**

Respectfully submitted,



Mike Westlake
Assistant Deputy Director
Development Services Department

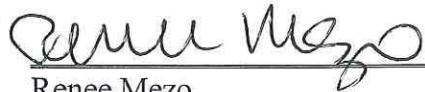

Renee Mezo
Development Project Manager
Development Services Department

WESTLAKE/RM

Attachments:

1. Aerial Photograph
2. Community Plan Land Use Map
3. Project Location Map
4. Project Data Sheet
5. Draft Permit Conditions
6. Draft Permit Resolution with Findings
7. Previous Conditional Use Permit No. 13107
8. Project Plans
9. Community Planning Group Recommendation
10. Ownership Disclosure Statement
11. Federal Aviation Administration Determination and Airport Land Use Commission Determination.



Project Site



Aerial Photo

OCEAN VIEW CHURCH- 2450 AND 2460 PALM AVENUE
PROJECT NO. 205163



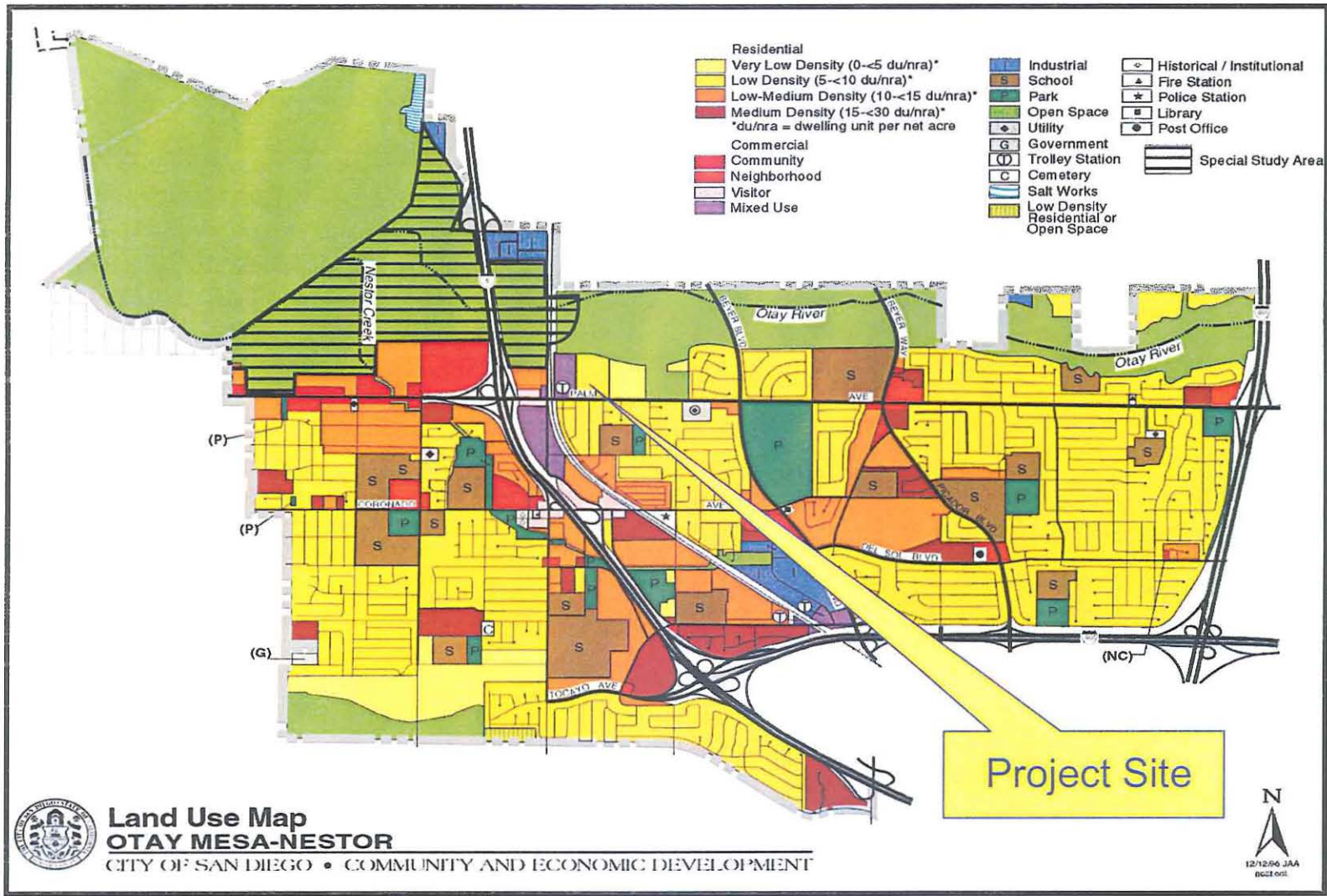

Land Use Map

OCEAN VIEW CHURCH- 2450 AND 2460 PALM AVENUE

PROJECT NO. 205163



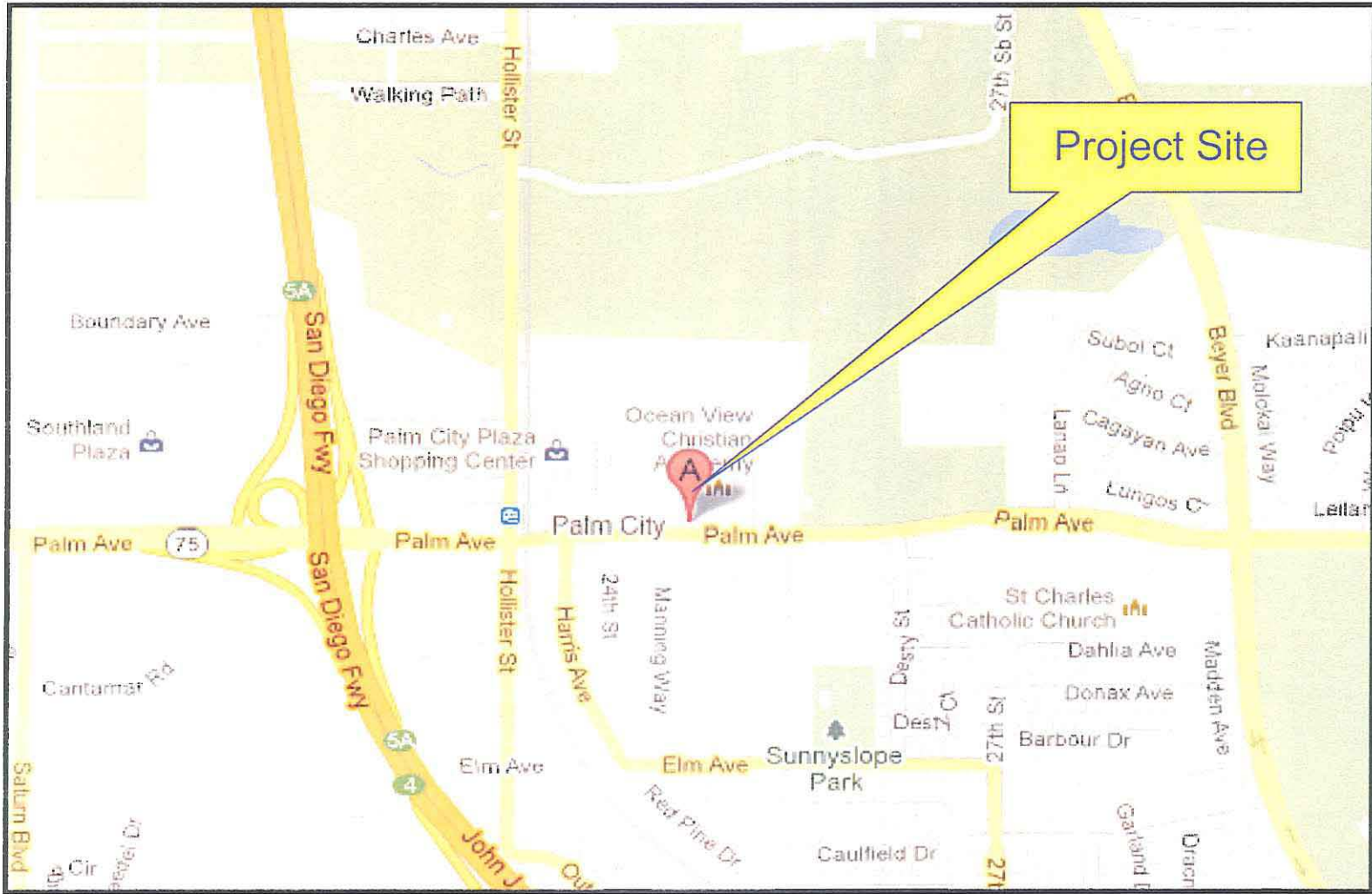

Project Location Map

**OCEAN VIEW CHURCH- 2450 AND 2460 PALM AVENUE
PROJECT NO. 205163**



PROJECT DATA SHEET

PROJECT NAME:	Ocean View Church - Project No. 205163	
PROJECT DESCRIPTION:	Expansion of an existing church and school with deviations, and a two-level parking structure on a 12.53-acre site	
COMMUNITY PLAN AREA:	Otay Mesa-Nestor Community Plan area	
DISCRETIONARY ACTIONS:	Planned Development Permit; Amendment to Conditional Use Permit (CUP) No. 13107	
COMMUNITY PLAN LAND USE DESIGNATION:	Very Low Density Residential (0<5 dwelling units per net acre)	
<u>ZONING INFORMATION:</u>		
ZONE: RS-1-7 and RS-1-2 Zones: (Residential single-family)		
HEIGHT LIMIT: 30		
LOT SIZE: 5,000/ 20,000square-foot minimum lot size		
FLOOR AREA RATIO: 0.45 maximum		
FRONT SETBACK: 15/25 feet (based on lot width)		
SIDE SETBACK: .08 feet (based on lot width)		
STREETSIDE SETBACK: .10 feet (based on lot width)		
REAR SETBACK: 13/25 feet		
PARKING: 272 parking spaces required		
<u>ADJACENT PROPERTIES:</u>	LAND USE DESIGNATION & ZONE	EXISTING LAND USE
NORTH:	Open Space; AR-1-2	Vacant land
SOUTH:	Low Density Residential; RS-1-7	Single-family residential
EAST:	Low Density Residential; RS-1-2	Single-family residential
WEST:	Mixed Use; RS-1-7	Single-family residential

<p>DEVIATIONS OR VARIANCES REQUESTED:</p>	<ol style="list-style-type: none"> 1. A deviation to allow a maximum height of 43'3" for the proposed Fellowship Hall/Chapel where a maximum of 30'-0" is permitted. 2. A deviation to allow a maximum height of 58'-8" and 51'-3" for the proposed church spires where a maximum of 30'-0" is permitted. 3. A deviation to allow a maximum height of 31'-6" for the proposed multi-purpose building where a maximum of 30'-0" is permitted. 4. A deviation to allow a maximum height of 40'-11" for the proposed parking structure where a maximum of 30'-0" is permitted. 5. A deviation to allow encroachments into the required side yard setbacks for the proposed improvements to the existing sports field including but not limited to dugouts, fencing and lighting. 6. A deviation to allow a side yard setback of 15'-0" for the proposed trash enclosure where 26'-6" is the minimum required. 7. A deviation to allow a side yard setback of 33'-3" for the proposed for the parking structure where 56'-0" is the minimum required. 8. A deviation to allow three retaining walls within the side yard setback where two are required and a deviation to allow a 4-foot separation between two of the retaining walls in the side yard where 6 feet is required. 9. A deviation to allow the construction of two monument ground signs where none are permitted in a residential zone.
<p>COMMUNITY PLANNING GROUP RECOMMENDATION:</p>	<p>At the May 11, 2011 meeting, the Otay Mesa-Nestor Planning Group voted 11-0-0 to recommend approval of the proposed project as submitted with no recommendations.</p>

RECORDING REQUESTED BY
CITY OF SAN DIEGO
DEVELOPMENT
SERVICES
 PERMIT INTAKE, MAIL STATION 501

PROJECT MANAGEMENT
PERMIT CLERK
MAIL STATION 501

SPACE ABOVE THIS LINE FOR RECORDER'S USE

INTERNAL ORDER NUMBER: 24000701

PLANNED DEVELOPMENT PERMIT NO. 727817
CONDITIONAL USE PERMIT NO. 727818

(AMENDMENT TO CONDITIONAL USE PERMIT NO.13107)
OCEAN VIEW CHURCH- PROJECT NO. 205163 (MMRP)
PLANNING COMMISSION
DRAFT

This Planned Development Permit No. 727817 and Conditional Use Permit No. 727818, (Amendment to Conditional Use Permit No. 13107), is granted by the Planning Commission of the City of San Diego to MIDWAY BAPTIST CHURCH, Owner/Permittee, pursuant to San Diego Municipal Code [SDMC] Sections 126.0602 and 126.0303. The 12.53-acre site is located at 2450 and 2460 Palm Avenue in the RS-1-7 and RS-1-2 zones, the Transit Area Overlay Zone, the Residential Tandem Parking Overlay Zone, the Airport Influence Area, and Federal Aviation Administration (FAA) Part 77 Notification Area Zones, within the Palm City area of the Otay Mesa-Nestor Community Plan. The project site is legally described as: Parcels 1-3 of Parcel Map No. 4417 and the west 660 feet of the Southeast Quarter of Section 22 in Township 18, San Bernardino Meridian (Assessor Parcel Numbers 628-050-47, 628-050-57 and 628-050-68).

Subject to the terms and conditions set forth in this Permit, permission is granted to MIDWAY BAPTIST CHURCH, Owner/Permittee, to construct an expansion of the existing church use, accessory office uses, a day camp, school (kindergarten through 12th grade) and child care uses, described and identified by size, dimension, quantity, type, and location on the approved exhibits [Exhibit "A"] dated December 13, 2012, on file in the Development Services Department.

The project shall include:

- a. New construction of a youth ministry building, a chapel/pre-school/multi-purpose building, weight room/lockers, day camp storage facility and garage, and multi-use building for a total of 134,995 square feet;

- b. Construction of a two-level, 13,825-square-foot parking structure;
- c. Remodeling of the existing multi-purpose sports field and construction of new bleachers and lighting for the field;
- d. Increased enrollment in pre-school, elementary, middle school and high school as detailed in Condition No. 50 and 51;
- e. Deviations for retaining walls, height, and setback encroachments, as detailed in Condition No. 48;
- f. Landscaping (planting, irrigation and landscape related improvements);
- g. Off-street parking and;
- h. Public and private accessory improvements determined by the Development Services Department to be consistent with the land use and development standards for this site in accordance with the adopted community plan, the California Environmental Quality Act [CEQA] and the CEQA Guidelines, the City Engineer's requirements, zoning regulations, conditions of this Permit, and any other applicable regulations of the SDMC.

STANDARD REQUIREMENTS:

1. This permit must be utilized within thirty-six (36) months after the date on which all rights of appeal have expired. If this permit is not utilized in accordance with Chapter 12, Article 6, Division 1 of the SDMC within the 36 month period, this permit shall be void unless an Extension of Time has been granted. Any such Extension of Time must meet all SDMC requirements and applicable guidelines in effect at the time the extension is considered by the appropriate decision maker. This permit must be utilized by December 28, 2015.
2. No permit for the construction, occupancy, or operation of any facility or improvement described herein shall be granted, nor shall any activity authorized by this Permit be conducted on the premises until:
 - a. The Owner/Permittee signs and returns the Permit to the Development Services Department; and
 - b. The Permit is recorded in the Office of the San Diego County Recorder.
3. While this Permit is in effect, the subject property shall be used only for the purposes and under the terms and conditions set forth in this Permit unless otherwise authorized by the appropriate City decision maker.

4. This Permit is a covenant running with the subject property and all of the requirements and conditions of this Permit and related documents shall be binding upon the Owner/Permittee and any successor(s) in interest.
5. The continued use of this Permit shall be subject to the regulations of this and any other applicable governmental agency.
6. Issuance of this Permit by the City of San Diego does not authorize the Owner/Permittee for this Permit to violate any Federal, State or City laws, ordinances, regulations or policies including, but not limited to, the Endangered Species Act of 1973 [ESA] and any amendments thereto (16 U.S.C. § 1531 et seq.).
7. The Owner/Permittee shall secure all necessary building permits. The Owner/Permittee is informed that to secure these permits, substantial building modifications and site improvements may be required to comply with applicable building, fire, mechanical, and plumbing codes, and State and Federal disability access laws.
8. Construction plans shall be in substantial conformity to Exhibit "A." Changes, modifications, or alterations to the construction plans are prohibited unless appropriate application(s) or amendment(s) to this Permit have been granted.
9. All of the conditions contained in this Permit have been considered and were determined necessary to make the findings required for approval of this Permit. The Permit holder is required to comply with each and every condition in order to maintain the entitlements that are granted by this Permit.

If any condition of this Permit, on a legal challenge by the Owner/Permittee of this Permit, is found or held by a court of competent jurisdiction to be invalid, unenforceable, or unreasonable, this Permit shall be void. However, in such an event, the Owner/Permittee shall have the right, by paying applicable processing fees, to bring a request for a new permit without the "invalid" condition(s) back to the discretionary body which approved the Permit for a determination by that body as to whether all of the findings necessary for the issuance of the proposed permit can still be made in the absence of the "invalid" condition(s). Such hearing shall be a hearing de novo, and the discretionary body shall have the absolute right to approve, disapprove, or modify the proposed permit and the condition(s) contained therein.

10. The Owner/Permittee shall defend, indemnify, and hold harmless the City, its agents, officers, and employees from any and all claims, actions, proceedings, damages, judgments, or costs, including attorney's fees, against the City or its agents, officers, or employees, relating to the issuance of this permit including, but not limited to, any action to attack, set aside, void, challenge, or annul this development approval and any environmental document or decision. The City will promptly notify Owner/Permittee of any claim, action, or proceeding and, if the City should fail to cooperate fully in the defense, the Owner/Permittee shall not thereafter be responsible to defend, indemnify, and hold harmless the City or its agents, officers, and employees. The City may elect to conduct its own defense, participate in its own defense, or obtain independent legal counsel in defense of any claim related to this indemnification. In the

event of such election, Owner/Permittee shall pay all of the costs related thereto, including without limitation reasonable attorney's fees and costs. In the event of a disagreement between the City and Owner/Permittee regarding litigation issues, the City shall have the authority to control the litigation and make litigation related decisions, including, but not limited to, settlement or other disposition of the matter. However, the Owner/Permittee shall not be required to pay or perform any settlement unless such settlement is approved by Owner/Permittee.

11. This Permit may be developed in phases. Each phase shall be constructed consistent with the conditions and exhibits approved for each respective phase per the approved Exhibit "A."

ENVIRONMENTAL/MITIGATION REQUIREMENTS:

12. Mitigation requirements in the Mitigation, Monitoring, and Reporting Program [MMRP] shall apply to this Permit. These MMRP conditions are hereby incorporated into this Permit by reference.

13. The mitigation measures specified in the MMRP and outlined in Mitigated Negative Declaration No. 205163, shall be noted on the construction plans and specifications under the heading ENVIRONMENTAL MITIGATION REQUIREMENTS.

14. The Owner/Permittee shall comply with the MMRP as specified in Mitigated Negative Declaration No. 205163, to the satisfaction of the Development Services Department and the City Engineer. Prior to issuance of any construction permit, all conditions of the MMRP shall be adhered to, to the satisfaction of the City Engineer. All mitigation measures described in the MMRP shall be implemented for the following issue areas:

Paleontological Resources and Biological Resources (Land Use/MSCP)

AIRPORT REQUIREMENTS:

15. Prior to the issuance of any building permits, the Owner/Permittee shall provide a copy of the signed agreement [DS-503] and show certification on the building plans verifying that the structures do not require Federal Aviation Administration [FAA] notice for Determination of No Hazard to Air Navigation, or provide an FAA Determination of No Hazard to Air Navigation as specified in Information Bulletin 520.

GEOLOGY REQUIREMENTS:

16. The Owner/Permittee shall submit a geotechnical investigation report or update letter that specifically addresses the proposed construction plans. The geotechnical investigation report or update letter shall be reviewed for adequacy by the Geology Section of the Development Services Department prior to issuance of any construction permits.

17. The Owner/Permittee shall submit an as-graded geotechnical report prepared in accordance with the City's "Guidelines for Geotechnical Reports" following completion of the grading. The as-graded geotechnical report shall be reviewed for adequacy by the Geology Section of the Development Services Department prior to exoneration of the bond and grading permit close-out.

ENGINEERING REQUIREMENTS:

18. The project proposes to export no material from the project site. Any excavated material that is exported shall be exported to a legal disposal site in accordance with the Standard Specifications for Public Works Construction (the "Green Book"), 2003 edition and Regional Supplement Amendments adopted by Regional Standards Committee.

19. The drainage system proposed for this development, as shown on the site plan, is private and subject to approval by the City Engineer.

20. Prior to the issuance of any building permits, the Owner/Permittee shall obtain a bonded grading permit for the grading proposed for this project. All grading shall conform to the requirements of the City of San Diego Municipal Code in a manner satisfactory to the City Engineer.

21. Prior to the issuance of any building permits, the Owner/Permittee shall assure, by permit and bond, the construction of three current City Standard 24-foot wide driveways, adjacent to the site on Palm Avenue, satisfactory to the City Engineer.

22. Prior to the issuance of any building permits, the Owner/Permittee shall dedicate an additional 5 feet on Palm Avenue to provide a 15-foot curb-to-property-line distance, satisfactory to the City Engineer.

23. Whenever street rights-of-way are required to be dedicated, it is the responsibility of the Owner/Permittee to provide the right-of-way free and clear of all encumbrances and prior easements. The Applicant must secure "subordination agreements" for minor distribution facilities and/or "joint-use agreements" for major transmission facilities.

24. Prior to the issuance of any building permits, the Owner/Permittee shall assure, by permit and bond, reconstructing of the existing curb ramp adjacent to the site at the intersection of Palm Avenue at Beejay Drive, with current City Standard curb ramp Standard Drawing SDG-137 with truncated domes, satisfactory to the City Engineer.

25. Prior to the issuance of any building permits, the Owner/Permittee shall assure, by permit and bond, closure of the non-utilized portions of the three driveways with current City Standard curb, gutter and sidewalk, adjacent to the site on Palm Avenue, satisfactory to the City Engineer.

26. Prior to the issuance of any building permits, the Owner/Permittee shall assure, by permit and bond, construction of current City Standard SDG-102 bus stop slab adjacent to the site on Palm Avenue, satisfactory to the City Engineer.

27. Prior to the issuance of any construction permit, the Owner/Permittee shall enter into a Maintenance Agreement for the ongoing permanent Best Management Practices (BMP) maintenance, satisfactory to the City Engineer.
28. Prior to the issuance of any construction permit, the Owner/Permittee shall incorporate any construction Best Management Practices necessary to comply with Chapter 14, Article 2, Division 1 (Grading Regulations) of the San Diego Municipal Code, into the construction plans or specifications.
29. Prior to the issuance of any construction permit the Owner/Permittee shall provide evidence of coverage under the General Industrial National Pollutant Discharge Elimination System, in the form of a Notice of Intent (NOI) filed with the State Water Resources Control Board.
30. Development of this project shall comply with all requirements of State Water Resources Control Board (SWRCB) Order No. 99-08 DWQ and the Municipal Storm Water Permit, Order No. 2001-01(NPDES General Permit No. CAS000002 and CAS0108758), Waste Discharge Requirements for Discharges of Storm Water Runoff Associated With Construction Activity. In accordance with said permit, a Storm Water Pollution Prevention Plan (SWPPP) and a Monitoring Program Plan shall be implemented concurrently with the commencement of grading activities, and a Notice of Intent (NOI) shall be filed with the SWRCB.
31. A copy of the acknowledgment from the SWRCB that an NOI has been received for this project shall be filed with the City of San Diego when received; further, a copy of the completed NOI from the SWRCB showing the permit number for this project shall be filed with the City of San Diego when received. In addition, the owner(s) and subsequent owner(s) of any portion of the property covered by this grading permit and by SWRCB Order No. 99 08 DWQ, and any subsequent amendments thereto, shall comply with special provisions as set forth in SWRCB Order No. 99 08 DWQ.
32. Prior to the issuance of any construction permit the Owner/Permittee shall incorporate and show the type and location of all post-construction Best Management Practices (BMP's) on the final construction drawings, consistent with the approved Water Quality Technical Report.
33. Any party, on whom fees, dedications, reservations, or other exactions have been imposed as conditions of approval of this development permit, may protest the imposition within 90 days of the approval of this development permit by filing a written protest with the City Clerk pursuant to California Government Code 66020.

LANDSCAPE REQUIREMENTS:

34. Prior to issuance of any engineering permits for grading, construction documents for the revegetation and hydroseeding of all disturbed land shall be submitted in accordance with the Landscape Standards and to the satisfaction of the Development Services Department. All plans shall be in substantial conformance to this permit (including Environmental conditions) and Exhibit 'A,' on file in the Development Services Department.

PLANNING COMMISSION RESOLUTION NO. XXXX
PLANNED DEVELOPMENT PERMIT NO. 727817
CONDITIONAL USE PERMIT NO. 727818

**(AMENDMENT TO CONDITIONAL USE PERMIT NO.13107)
OCEAN VIEW CHURCH - PROJECT NO. 205163 - MMRP
DRAFT**

WHEREAS, MIDWAY BAPTIST CHURCH, Owner/Permittee, filed an application with the City of San Diego for permits to expand the existing church use and construct new accessory office uses, day camp, school (kindergarten through 12th grade) and child care uses with deviations, (as described in and by reference to the approved Exhibits "A" and corresponding conditions of approval for the associated Planned Development Permit No. 727817/Conditional Use Permit No. 727818), on portions of a 12.53-acre site;

WHEREAS, the project site is located at 2450 and 2460 Palm Avenue in the RS-1-7 and RS-1-2 Zones, the Transit Area Overlay Zone, the Residential Tandem Parking Overlay Zone, the Airport Influence Area, and Federal Aviation Administration (FAA) Part 77 Notification Area Zones, within the Palm City area of the Otay Mesa-Nestor Community Plan;

WHEREAS, the project site is legally described as: Parcels 1-3 of Parcel Map No. 4417 and the west 660 feet of the Southeast Quarter of the Southwest Quarter of Section 22 in Township 18, San Bernardino Meridian (Assessor Parcel Numbers 628-050-47, 628-050-57 and 628-050-68);

WHEREAS, on December 13, 2012, the Planning Commission of the City of San Diego considered Planned Development Permit No. 727817 and Conditional Use Permit No. 727818 pursuant to the Land Development Code of the City of San Diego; NOW, THEREFORE,

BE IT RESOLVED by the Planning Commission of the City of San Diego as follows:

That the Planning Commission adopts the following written Findings, dated December 13, 2012:

PLANNED DEVELOPMENT PERMIT FINDINGS - SECTION 126.0604:

1. The proposed development will not adversely affect the applicable land use plan.

The Ocean View Church project is a request to construct a five-phase expansion of the existing church use including new construction of accessory office uses, a day camp, school (kindergarten through 12th grade), athletic fields and child care with deviations. The 12.53-acre site is located at 2450 and 2460 Palm Avenue in the RS-1-7 and RS-1-2 Zones, the Transit Area Overlay Zone, the Residential Tandem Parking Overlay Zone, the Airport Influence Area, and the Federal Aviation Administration (FAA) Part 77 Notification Area, within the Palm City area of the Otay Mesa-Nestor Community Plan.

The Otay Mesa-Nestor Community Plan designates the project site as Very Low Density Residential (0-5 dwelling units per net acre). The Community Plan doesn't specifically discuss church uses within residential zones but the existing church pre-dates the adoption of the Community Plan in 1979. City-wide, churches are allowed in residential zones with a Conditional Use Permit. The project complies with the Federal Aviation Administration Part 77 Noticing Area (NOLF Imperial Beach) and the Airport Influence Area (Brown Field). The Federal Aviation Administration (FAA) conducted an aeronautical study for the project and determined the building's maximum height of 59 feet (for the church tower) will not cause aeronautical hazards to air space as regulated by the FAA and Brown Field and the San Diego County Regional Airport Authority land use regulations. Therefore, the proposed development will not adversely affect the applicable land use plan.

2. The proposed development will not be detrimental to the public health, safety, and welfare.

The Ocean View Church project is a request to construct a five-phase expansion of the existing church use including new construction of accessory office uses, a day camp, school (kindergarten through 12th grade), athletic fields and child care with deviations. The 12.53-acre site is located at 2450 and 2460 Palm Avenue in the RS-1-7 and RS-1-2 Zones, the Transit Area Overlay Zone, the Residential Tandem Parking Overlay Zone, the Airport Influence Area, and the Federal Aviation Administration (FAA) Part 77 Notification Area, within the Palm City area of the Otay Mesa-Nestor Community Plan.

The project complies with the Federal Aviation Administration Part 77 Noticing Area (NOLF Imperial Beach) and the Airport Influence Area (Brown Field). The Federal Aviation Administration (FAA) conducted an aeronautical study for the project and determined the building's maximum height of 59 feet (for the church tower) will not cause aeronautical hazards to air space as regulated by the FAA and Brown Field and the San Diego County Regional Airport Authority land use regulations.

A Mitigated Negative Declaration (MND) was prepared in accordance with the State of California Environmental Quality Act (CEQA) Guidelines. The proposed project includes mitigation measures to offset potential impacts to Biological Resources (Land Use/MSCP) and Paleontology. Implementation of the Mitigation, Monitoring and Reporting Program as well as permit conditions, would reduce potential impacts to below a level of significance.

All Uniform Building, Fire, Plumbing, Electrical, Mechanical Code and City regulations governing the construction and continued operation of the development apply to this project to prevent adverse effects to those persons or properties in the vicinity of the project. Therefore, the proposed development will not be detrimental to the public health, safety and welfare.

- 3. The proposed development will comply with the regulations of the Land Development Code including any proposed deviations pursuant to Section 126.0602(b)(1) that are appropriate for this location and will result in a more desirable project than would be achieved if designed in strict conformance with the development regulations of the applicable zone; and any allowable deviations that are otherwise authorized pursuant to the Land Development Code.**

The Ocean View Church project is a request to construct a five-phase expansion of the existing church use including new construction of accessory office uses, a day camp, school (kindergarten through 12th grade), athletic fields and child care with deviations. The 12.53-acre site is located at 2450 and 2460 Palm Avenue in the RS-1-7 and RS-1-2 Zones, the Transit Area Overlay Zone, the Residential Tandem Parking Overlay Zone, the Airport Influence Area, and the Federal Aviation Administration (FAA) Part 77 Notification Area, within the Palm City area of the Otay Mesa-Nestor Community Plan.

The proposed project complies with all the applicable development regulations of the RS-1-7 and RS-1-2 Zones, except for the nine proposed deviations, which are allowed through the Planned Development Permit process. The requested deviations include:

- a. A deviation to allow a maximum height of 43'-3" for the proposed Fellowship Hall/Chapel where a maximum of 30'-0" is permitted.
- b. A deviation to allow the maximum heights of 58'-8" and 51'-3" for the proposed church tower and spire where a maximum of 30'-0" is permitted.
- c. A deviation to allow a maximum height of 31'-6" for the proposed multi-purpose building where a maximum of 30'-0" is permitted.
- d. A deviation to allow a maximum height of 40'-11" for the proposed parking structure where a maximum of 30'-0" is permitted.
- e. A deviation to allow encroachments into the required side yard setbacks for the proposed improvements to the existing sports field including but not limited to dugouts, fencing and lighting.
- f. A deviation to allow a side yard setback of 15'-0" for the proposed trash enclosure where 26'-6" is the minimum required.
- g. A deviation to allow a side yard setback of 33'-3" for the proposed parking structure where 56'-0" is the minimum required.
- h. A deviation to allow three retaining walls within the side yard setback where two are allowed; and a deviation to allow a 4-foot separation between two of the retaining walls in the side yard setback where 6 feet is required.

- i. A deviation to allow the construction of two monument ground signs where none are permitted in a residential zone.

Height Deviations (a-d): The underlying RS-1-7 and RS-1-2 zones both limit height to a maximum of 30 feet, which is consistent with lower density residential development. The current Ocean View Church campus contains six existing non-residential structures that were separately constructed over a period of 35 years, and employ a variety of designs, architectural styles, and structure heights varying from 15 feet to 48 feet in height. Prior to 2000, deviations were allowed with the approval of a CUP, as was the case with the existing church towers built in 1977 at 48 feet. Any existing structures that deviate are not required to be identified as a deviation in a new permit.

The proposed project's goal is to provide a more cohesive, organized and interconnected design that will unite the older existing buildings with the new proposed parking structure, multi-purpose building, and Fellowship Hall/Chapel. The proposed site design would create a cohesive campus environment with a central courtyard to provide a direct and clear focal point and connection for the students. The proposed deviations to allow buildings taller than the zone allows (30-feet) is essential and fundamental to the goal of providing a more consistent, cohesive, and interconnected campus design.

The church tower marks the entry to the main doors of the lobby into the Sanctuary. The glass and steel tower is square at nine feet by nine feet and tapers to six feet by six feet at a height of 52 feet, which is the height of the tower roof. Above 52 feet a steel cross extends another 6'-8" for a maximum height of 58'-8" above the adjacent grade. At the Northwest corner of the Fellowship/Chapel building, a steel cross is attached to the building that extends 10 feet above the roof of the building for a maximum height of 51'-3". The steel cross measures 24 feet total in height and six feet in width. The cross is angled toward the playing field which creates a visual connection for participants and visitors. The deviations for the church tower and spire allow for a visual icon and landmark for the existing church. Staff has determined all deviations for the increased height are consistent with the purpose and intent of the regulation would allow for a more functional project and would not adversely affect the surrounding community.

Setback Deviations (e-g): The deviations related to encroachments within the setbacks are for a new trash enclosure, parking structure, and improvements to the athletic fields. The calculation for the side yard setbacks are determined by the lot width. Due to the large size of the lots relative to the surrounding lots and split zoning, each parcel results in sizeable side yard setback requirements. The project's off-setting planes, building material and landscaping provide articulation that reduces the apparent bulk and scale of the structures. Staff has analyzed the deviations to setbacks and concluded there is still adequate distance within the setback to meet the intent of the regulations to provide free flow of light and air, and adequate separation from adjacent development.

The deviation for the placement of the dugouts, fencing and lighting for the athletic field within the side yard setback allows for flexibility during construction. The light pole at the northwest corner would be a minimum of four feet from the property line. The other light pole at the western property would be a minimum of 11 feet from the property line.

Retaining Wall Deviations (h): The proposed project requests a deviation to allow three retaining walls within the side yard setback where two are allowed, and a deviation to allow a four-foot separation between two of the retaining walls in the side yard where six feet is required. In order to align the parking structure with the rest of the campus, the proposed grade would increase approximately 17 feet. The western edge of the parking structure requires three retaining walls in order to accommodate this change in existing grade. Staff determined this deviation is minor and would allow for a more functional project and would not adversely affect the surrounding community.

Signage Deviation (i): The church has been in operation since 1976 and signage currently exists to direct congregants and staff to the site. The project proposes two monument ground signs. The increase in signage proposed provides for the continued operation and function of a church. The signs have been reviewed for consistency with size and location requirements of the underlying zone, and have been determined to be appropriate for this use.

The proposed development will comply with the regulations of the Land Development Code, including the proposed deviations which are minor in scope, appropriate for this location, and will result in a more desirable project than would be achieved if designed in strict conformance with the development regulations of the applicable zone.

CONDITIONAL USE PERMIT FINDINGS - SECTION 126.0305

1. The proposed development will not adversely affect the applicable land use plan.

The Ocean View Church project is a request to construct a five-phase expansion of the existing church use including new construction of accessory office uses, a day camp, school (kindergarten through 12th grade), athletic fields and child care with deviations. The 12.53-acre site is located at 2450 and 2460 Palm Avenue in the RS-1-7 and RS-1-2 Zones, the Transit Area Overlay Zone, the Residential Tandem Parking Overlay Zone, the Airport Influence Area, and the Federal Aviation Administration (FAA) Part 77 Notification Area, within the Palm City area of the Otay Mesa-Nestor Community Plan.

The Otay Mesa-Nestor Community Plan designates the project site as Very Low Density Residential (0-5 dwelling units per net acre). The Community Plan doesn't specifically discuss church uses within residential zones but the existing church pre-dates the adoption of the Community Plan in 1979. City-wide, churches are allowed in residential zones with a Conditional Use Permit. The project complies with the Federal Aviation Administration Part 77 Noticing Area (NOLF Imperial Beach) and the Airport Influence Area (Brown Field). The Federal Aviation Administration (FAA) conducted an aeronautical study for the project and determined the building's maximum height of 59

feet (for the church tower) will not cause aeronautical hazards to air space as regulated by the FAA and Brown Field and the San Diego County Regional Airport Authority land use regulations. Therefore, the proposed development will not adversely affect the applicable land use plan.

2. The proposed development will not be detrimental to the public health, safety, and welfare.

The Ocean View Church project is a request to construct a five-phase expansion of the existing church use including new construction of accessory office uses, a day camp, school (kindergarten through 12th grade), athletic fields and child care with deviations. The 12.53-acre site is located at 2450 and 2460 Palm Avenue in the RS-1-7 and RS-1-2 Zones, the Transit Area Overlay Zone, the Residential Tandem Parking Overlay Zone, the Airport Influence Area, and the Federal Aviation Administration (FAA) Part 77 Notification Area, within the Palm City area of the Otay Mesa-Nestor Community Plan.

The project complies with the Federal Aviation Administration Part 77 Noticing Area (NOLF Imperial Beach) and the Airport Influence Area (Brown Field). The Federal Aviation Administration (FAA) conducted an aeronautical study for the project and determined the building's maximum height of 59 feet (for the church tower) will not cause aeronautical hazards to air space as regulated by the FAA and Brown Field and the San Diego County Regional Airport Authority land use regulations.

A Mitigated Negative Declaration (MND) was prepared in accordance with the State of California Environmental Quality Act (CEQA) Guidelines. The propose project includes mitigation measures to offset potential impacts to Biological Resources (Land Use/MSCP) and Paleontology. Implementation of the Mitigation, Monitoring and Reporting Program, as well as permit conditions, would reduce potential impacts to below a level of significance. Therefore, the proposed development will not be detrimental to the public health, safety and welfare.

3. The proposed development will comply with the applicable regulations of the Land Development Code, including any allowable deviations pursuant to the Land Development Code.

The Ocean View Church project is a request to construct a five-phase expansion of the existing church use including new construction of accessory office uses, a day camp, school (kindergarten through 12th grade), athletic fields and child care with deviations. The 12.53-acre site is located at 2450 and 2460 Palm Avenue in the RS-1-7 and RS-1-2 Zones, the Transit Area Overlay Zone, the Residential Tandem Parking Overlay Zone, the Airport Influence Area, and the Federal Aviation Administration (FAA) Part 77 Notification Area, within the Palm City area of the Otay Mesa-Nestor Community Plan.

The proposed project complies with all the applicable development regulations of the RS-1-7 and RS-1-2 Zones, except for the nine proposed deviations, which are allowed through the Planned Development Permit process.

The requested deviations include:

- a. A deviation to allow a maximum height of 43'-3" for the proposed Fellowship Hall/Chapel where a maximum of 30'-0" is permitted.
- b. A deviation to allow the maximum heights of 58'-8" and 51'-3" for the proposed church tower and spire where a maximum of 30'-0" is permitted.
- c. A deviation to allow a maximum height of 31'-6" for the proposed multi-purpose building where a maximum of 30'-0" is permitted.
- d. A deviation to allow a maximum height of 40'-11" for the proposed parking structure where a maximum of 30'-0" is permitted.
- e. A deviation to allow encroachments into the required side yard setbacks for the proposed improvements to the existing sports field including but not limited to dugouts, fencing and lighting.
- f. A deviation to allow a side yard setback of 15'-0" for the proposed trash enclosure where 26'-6" is the minimum required.
- g. A deviation to allow a side yard setback of 33'-3" for the proposed parking structure where 56'-0" is the minimum required.
- h. A deviation to allow three retaining walls within the side yard setback where two are allowed; and a deviation to allow a 4-foot separation between two of the retaining walls in the side yard setback where 6 feet is required.
- i. A deviation to allow the construction of two monument ground signs where none are permitted in a residential zone.

Height Deviations (a-d): The underlying RS-1-7 and RS-1-2 zones both limit height to a maximum of 30 feet, which is consistent with lower density residential development. The current Ocean View Church campus contains six existing non-residential structures that were separately constructed over a period of 35 years, and employ a variety of designs, architectural styles, and structure heights varying from 15 feet to 48 feet in height. Prior to 2000, deviations were allowed with the approval of a CUP, as was the case with the existing church towers built in 1977 at 48 feet. Any existing structures that deviate are not required to be identified as a deviation in a new permit.

The proposed project's goal is to provide a more cohesive, organized and interconnected design that will unite the older existing buildings with the new proposed parking structure, multi-purpose building, and Fellowship Hall/Chapel. The proposed site design would create a cohesive campus environment with a central courtyard to provide a direct and clear focal point and connection for the students. The proposed deviations to allow

buildings taller than the zone allows (30-feet) is essential and fundamental to the goal of providing a more consistent, cohesive, and interconnected campus design.

The church tower marks the entry to the main doors of the lobby into the Sanctuary. The glass and steel tower is square at nine feet by nine feet and tapers to six feet by six feet at a height of 52 feet, which is the height of the tower roof. Above 52 feet a steel cross extends another 6'-8" for a maximum height of 58'-8" above the adjacent grade. At the Northwest corner of the Fellowship/Chapel building, a steel cross is attached to the building that extends 10 feet above the roof of the building for a maximum height of 51'-3". The steel cross measures 24 feet total in height and six feet in width. The cross is angled toward the playing field which creates a visual connection for participants and visitors. The deviations for the church tower and spire allow for a visual icon and landmark for the existing church. Staff has determined all deviations for the increased height are consistent with the purpose and intent of the regulation would allow for a more functional project and would not adversely affect the surrounding community.

Setback Deviations (e-g): The deviations related to encroachments within the setbacks are for a new trash enclosure, parking structure, and improvements to the athletic fields. The calculation for the side yard setbacks are determined by the lot width. Due to the large size of the lots relative to the surrounding lots and split zoning, each parcel results in sizeable side yard setback requirements. The project's off-setting planes, building material and landscaping provide articulation that reduces the apparent bulk and scale of the structures. Staff has analyzed the deviations to setbacks and concluded there is still adequate distance within the setback to meet the intent of the regulations to provide free flow of light and air, and adequate separation from adjacent development.

The deviation for the placement of the dugouts, fencing and lighting for the athletic field within the side yard setback allows for flexibility during construction. The light pole at the northwest corner would be a minimum of four feet from the property line. The other light pole at the western property would be a minimum of 11 feet from the property line.

Retaining Wall Deviations (h): The proposed project requests a deviation to allow three retaining walls within the side yard setback where two are allowed, and a deviation to allow a four-foot separation between two of the retaining walls in the side yard where six feet is required. In order to align the parking structure with the rest of the campus, the proposed grade would increase approximately 17 feet. The western edge of the parking structure requires three retaining walls in order to accommodate this change in existing grade. Staff determined this deviation is minor and would allow for a more functional project and would not adversely affect the surrounding community.

Signage Deviation (i): The church has been in operation since 1976 and signage currently exists to direct congregants and staff to the site. The project proposes two monument ground signs. The increase in signage proposed provides for the continued operation and function of a church. The signs have been reviewed for consistency with size and location requirements of the underlying zone, and have been determined to be appropriate for this use.

The proposed development will comply with the regulations of the Land Development Code, including the proposed deviations which are minor in scope, appropriate for this location, and will result in a more desirable project than would be achieved if designed in strict conformance with the development regulations of the applicable zone.

4. The proposed use is appropriate at the proposed location.

The Ocean View Church project is a request to construct a five-phase expansion of the existing church use, accessory office uses, a day camp, school (kindergarten through 12th grade), athletic fields and child care with deviations. The 12.53-acre site is located at 2450 and 2460 Palm Avenue in the RS-1-7 and RS-1-2 Zones, the Transit Area Overlay Zone, the Residential Tandem Parking Overlay Zone, the Airport Influence Area, and the Federal Aviation Administration (FAA) Part 77 Notification Area, within the Palm City area of the Otay Mesa-Nestor Community Plan.

The church has operated continuously on the site since 1976. The Otay Mesa-Nestor Community Plan designates the project site as Very Low Density Residential (0-5 dwelling units per net acre). The Community Plan doesn't specifically discuss church uses within residential zones but the existing church pre-dates the adoption of the Community Plan in 1979. City-wide, churches are allowed in residential zones with a Conditional Use Permit. The project proposes 425 parking spaces where 272 parking spaces are required on the site. Conditions applied to the project would also provide for safe and efficient access to the site. Therefore the use is appropriate at this location.

BE IT FURTHER RESOLVED that, based on the findings hereinbefore adopted by the Planning Commission, Planned Development Permit No. 727817 and Conditional Use Permit No. 727818 are hereby GRANTED by the Planning Commission to the referenced Owner/Permittee, in the form, exhibits, terms and conditions as set forth in Permit Nos. 727817 and 727818, a copy of which is attached hereto and made a part hereof.

Renee Mezo
Development Project Manager
Development Services

Adopted on: December 13, 2012
Internal Order No. 2400701

ATTACHMENT 7

CITY OF SAN DIEGO-DECISION OF THE ZONING ADMINISTRATOR-CASE NO. 13107
CONDITIONAL USE PERMIT - (HEARING)

The Zoning Administrator has considered the request of MIDWAY BAPTIST CHURCH, Purchaser, and ROSE M. WAGNER and WILLIAM HARMATZ, Owners, to construct church with parking and appurtenant facilities at 2460 Palm Avenue between Hollister Street and Beyer Boulevard - Portion Section 22, T18S, R2W, Zone R-1-5; and after consideration of the following findings of facts, has made the following decision:

APPROVED, subject to the following conditions:

1. That the parcel map shall be filed prior to issuance of any building permits;
2. That 121 parking spaces shall be allowed on the first phase;
3. That the parking area shall be installed in accordance with Division 8 of the Municipal Code;
4. That detailed landscape plans showing plant materials and watering system shall be submitted to and approved by the Zoning Administrator prior to issuance of any permits;
5. That in the parking and landscaping plan it shall be indicated where and how they will screen the church buses from view;
6. That the property shall be enclosed, but something less than a block wall will be acceptable, solid wood fence or chain link with slats;
7. That the future play area and school plans shall be reviewed before they are installed; if there are to be lights, they shall be directed to illuminate only on the play area and not shine on adjacent property;
8. That parking shall be provided at a ratio of 1:4 for the seats in the main sanctuary; that much will be needed with the total program and the school;

CASE NO. 13107/CONDITIONAL USE PERMIT

Page 2

9. That Building Inspection Department requirements, as well as any other interested Governmental Agency shall be complied with.

FINDING OF FACTS

After thorough consideration of the statements contained in the application, the report of the Investigator thereon, a study of the plans, a personal inspection of the property and the surrounding district, and the statements made before the Zoning Administrator at the hearing on August 15, 1975, all of which are by reference made a part hereof, it was found that the four requirements for granting a variance as enumerated in Section 101.0503 of the Municipal Code have been established by the following facts and the Negative Environmental Impact Report dated 6/16/75:

THE SUBJECT PROPERTY is a large parcel roughly rectangular in shape, with frontage on a dedicated right-of-way. Palm Avenue is in the process of being widened from the I-5 Interchange East to Beyer Blvd. Acquisitions for the street widening are being developed by the City of San Diego Property Department. The property is slightly sloping to the west and has dwellings existing on the two properties involved.

Surrounding area consists of single family dwellings, and directly adjacent westerly is a large mobilehome park. On Manning Lane, beginning at the southwest corner of the property, there is a small tract of single family dwellings approximately 80% completed. These homes are all located on the east side of Manning Lane.

The proposed church complex will consist of several structures including the sanctuary, future school area, future gymnasium, tennis courts, football and baseball playing fields. The installation will be accomplished in two phases of construction and development.

Parking requirements based on one space for each four seats in the main sanctuary will require 150 spaces. Plans indicate 121 spaces will be provided in the first phase of construction, with 90 spaces to be provided in later construction.

1. The proposed use at the particular location is desirable to provide a service or facility which will contribute to the general well-being of the neighborhood or community.
2. The proposed use will not be detrimental to the public health, safety or general welfare of persons residing or working in the vicinity or injurious to property or improvements in the vicinity.
3. The proposed use will comply with the regulations specified in the Code for such use.
4. The granting of the Conditional Use Permit will not adversely affect the PROGRESS GUIDE AND GENERAL PLAN OF THE CITY OF SAN DIEGO or the adopted plan of any governmental agency.

This Conditional Use Permit is not a permit or license and any permits and licenses required by law must be obtained from the proper department. Furthermore, if any condition of this Grant is violated, or if the same be not complied with in every respect, then this Conditional Use Permit shall be subject to revocation; provided, however, that after being notified in writing by the City that a condition has been violated and that subject permit is null and void within ten (10) days, an appeal may be filed with the Board of Zoning Appeals to show cause why subject permit should be reinstated.

Failure to utilize such Conditional Use Permit within the eighteen (18) month period will automatically void the same, in accordance with Municipal Code Section 101.0508. Except as provided in Section 101.0509, during the eighteen (18) month period referred to in this Section, the property covered by a conditional use permit granted by the Zoning Administrator shall not be used for any purpose other than that authorized by the permit.

The permission granted by this Conditional Use Permit shall become effective and final on the eleventh day after it is filed in the Office of the City Clerk; said appeal to be filed in Zoning Administration, Third Floor, City Operations Building, 1222 First Avenue. An appeal from any decision of the Zoning Administrator may be taken to the Board of Zoning Appeals by the applicant, any governmental body or agency, by any owner of real property located within the City or by any resident of the City. See Municipal Code Section 101.0504.

**FILED IN OFFICE
OF CITY CLERK**

SEP 3 1975

CITY PLANNING DEPARTMENT

Voyd H. Beights
Voyd H. Beights
Zoning Administrator

VHB:JAR:wpc
CC: both owners

RIGHT OF APPEAL expires
10 DAYS
after the above date.

STATE OF CALIFORNIA^{ss}
COUNTY OF SAN DIEGO

On this _____ day of _____, 197____, before me _____
_____, a Notary Public in and for said County,

Applicant shall have agreed to each and every condition hereof by having this conditional use permit signed within thirty (30) days of the decision of the Zoning Administrator.

The undersigned Permittee by execution hereof agrees to each and every condition of this conditional use permit and promises to perform each and every obligation of Permittee hereunder.

Midway Baptist Church

Rose M. Wagner
Rose M. Wagner

William Harmetz

(ATTACH CORPORATE JURAT FOR CHURCH)

State of California)
County of San Diego) ss

On this 28th day of August, 1970, before me Darlene K. Rinehart, a Notary Public in and for said County, residing therein, duly commissioned and sworn, personally appeared Rose M. Wagner known to me to be the person(~~s~~) described in and whose name(~~s~~) is(~~are~~) subscribed to the within instrument and acknowledged to me that she executed the same.

IN WITNESS WHEREOF, I have hereunto set my hand and affixed my Official Seal at my office in San Diego, County of San Diego, State of California, the day and year in this certificate first above written.

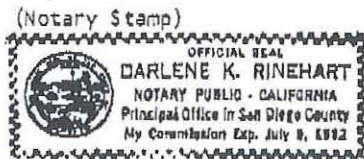

Darlene K. Rinehart
Notary Public in and for the County of San Diego, State of California

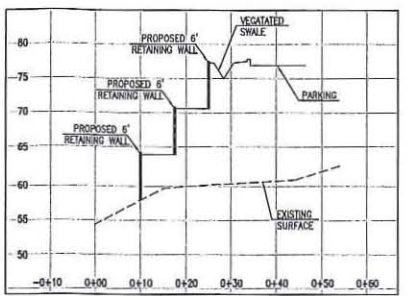
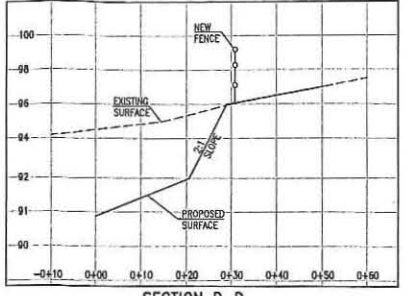
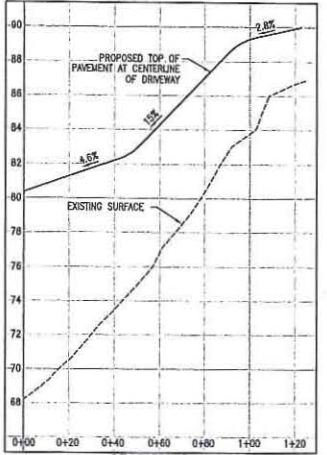
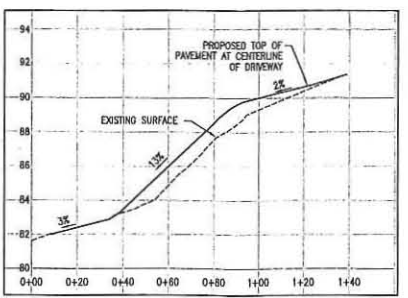
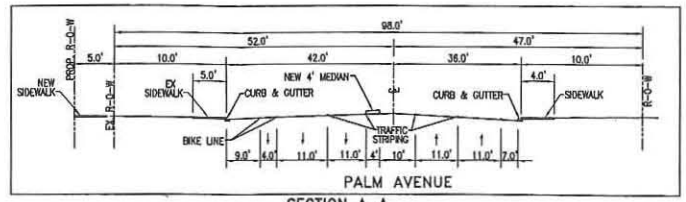
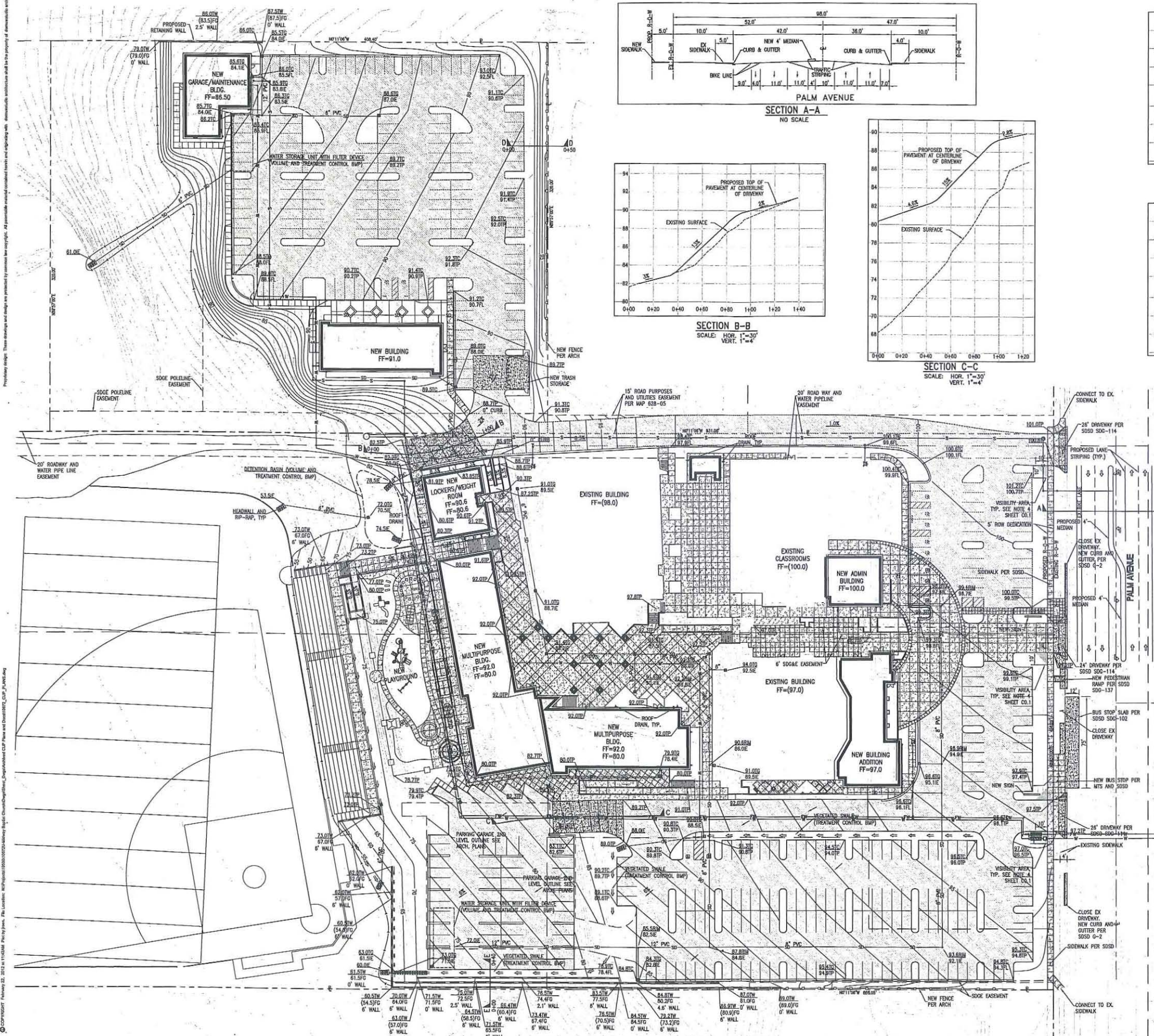

GRADING QUANTITIES

TOTAL AMOUNT OF SITE TO BE GRADED: AREA 9.02 AC. % OF TOTAL SITE 72%
 AMOUNT OF CUT: 13,567 CUBIC YARDS AND MAXIMUM DEPTH OF CUT: 11.7 FEET
 AMOUNT OF FILL: 21,282 CUBIC YARDS AND MAXIMUM DEPTH OF FILL: 15.3 FEET
 MAXIMUM HEIGHT OF FILL SLOPE(S): 20 FEET 2:1 SLOPE RATIO
 MAXIMUM HEIGHT OF CUT SLOPE(S): 12 FEET 2:1 SLOPE RATIO
 AMOUNT OF IMPORT SOIL: 7,715 CUBIC YARDS
 RETAINING/CRIB WALLS: LENGTH 892 FEET; MAXIMUM HEIGHT 6 FEET.

IMPROVEMENTS LEGEND

- STORM DRAIN INLET
- STORM DRAIN PIPE
- VEGETATED SWALE
- CONCRETE BROW DITCH
- RUNOFF FLOW DIRECTION
- PROPOSED CONTOURS
- EXISTING SPOT ELEVATION
- PROPOSED SPOT ELEVATION
- PROPOSED ASPHALT PAVEMENT
- CONCRETE SIDEWALK
- CONCRETE PAVEMENT
- RETAINING WALL
- 6" CURB & GUTTER W/ CURB CUTS
- STORM DRAIN SMALL CLEANOUT

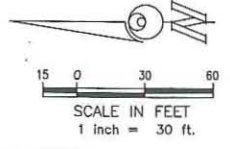

BURKETT & WONG ENGINEERS
 ENGINEERS & SURVEYORS
 3434 FOURTH AVE. SAN DIEGO CA.
 92103-5704 (619) 299-5550

Contact: domusstudio architecture
 JOHN PEZAR
 Address: 2150 W. WASHINGTON ST., STE. 303
 SAN DIEGO, CA 92110
 Phone/Fax: TEL: 619-692-9393 EXT. 14
 FAX 619-692-9394

Project Name: **Ocean View Church**

Sheet Title: **Grading and Drainage Plan**

Proprietary design. These drawings and design are prepared by common law copyright. All particular design elements and detailing shall be the property of domesticstudio architecture.

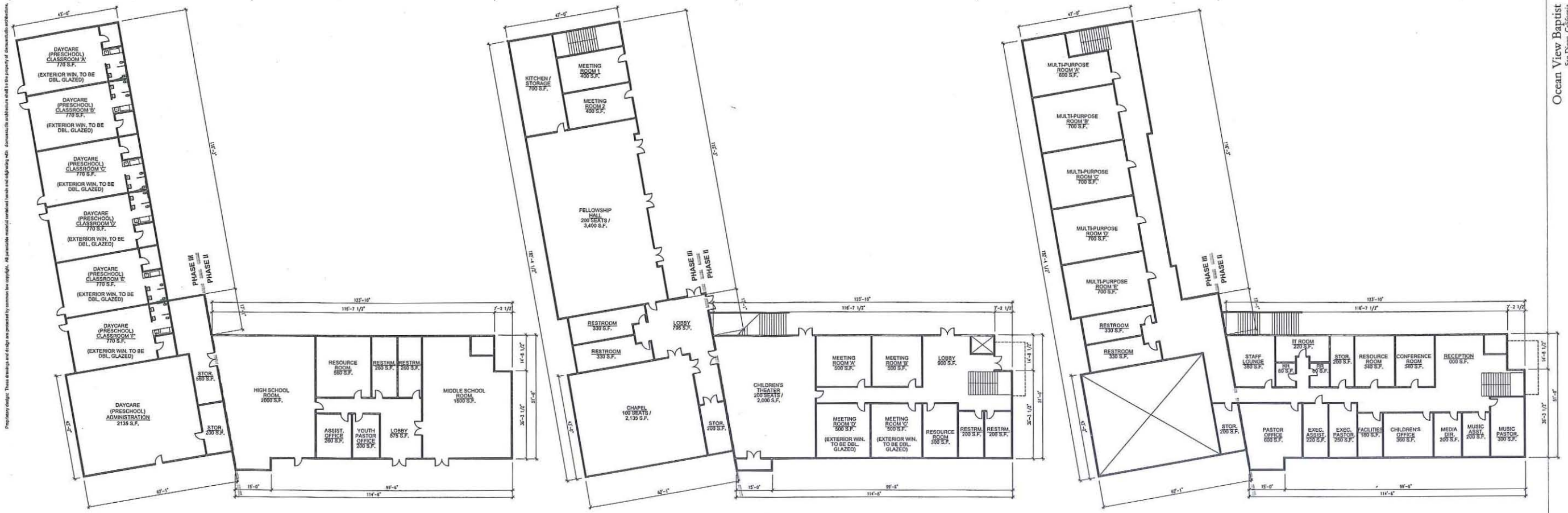

Preschool & Youth - Lower Level (Phases II & III)
9,900 S.F. / 4,000 S.F.

Fellowship Hall & Children's Ministry - Grade Level (Phases II & III)
9,900 S.F. / 4,000 S.F.

Church Admin. & Multi-purpose Rooms - Upper Level (Phases II & III)
8,200 S.F. / 4,000 S.F.

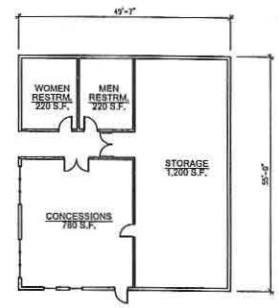

Concessions / Locker Rm - Lower Level (Phase IV)
2,725 S.F.

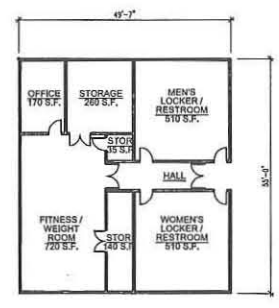

Concessions / Locker Room - Upper Level (Phase IV)
2,725 S.F.

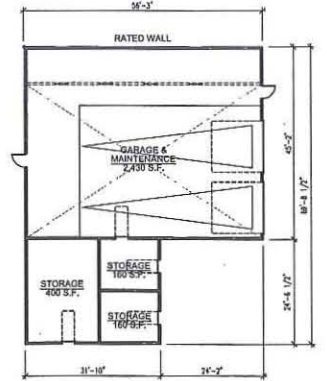

Day Camp Storage and Garage (Phase I)
3,225 S.F.

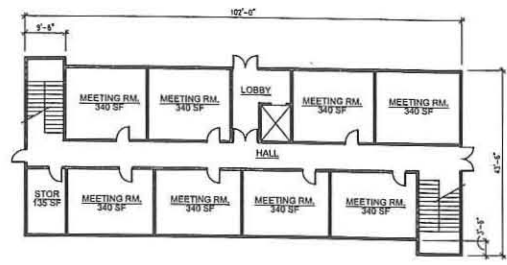

Multi-Purpose Room - Lower Level (Phase V)
4,150 S.F.

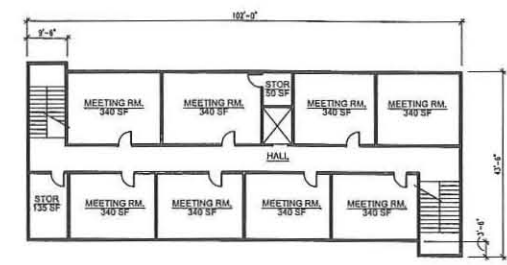

Multi-Purpose Room - Upper Level (Phase V)
3,850 S.F.

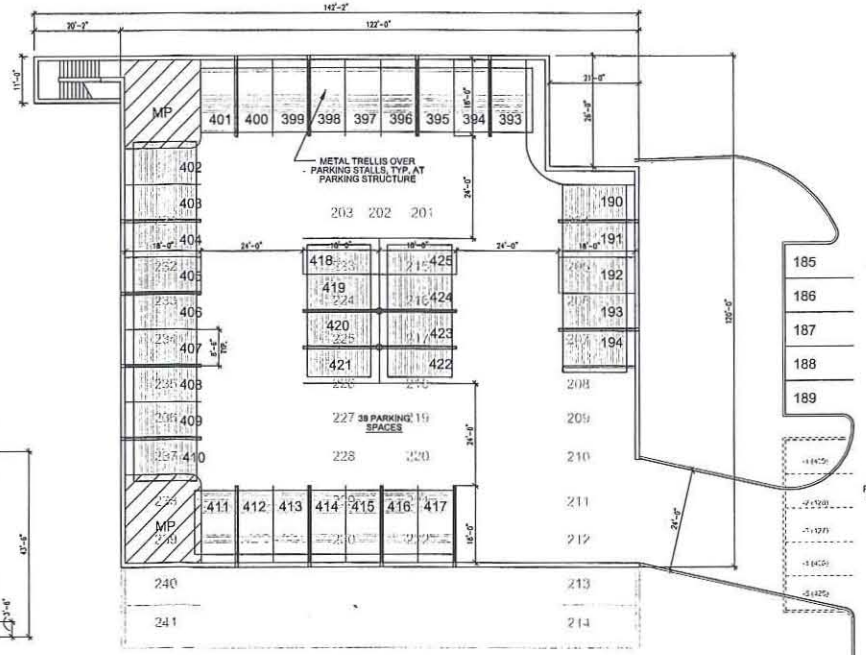

Parking Structure (Phase V)



Contact: domesticstudio architecture
2150 W. WASHINGTON ST., STE. 303
SAN DIEGO, CA 92110
TEL: 619-492-9339 EXT. 14
FAX: 619-492-9394

Project Address:
2460 PALM AVE
SAN DIEGO, CALIFORNIA 92154
A.P.N. 628-050-47-00; 628-050-57-00; 628-050-46-00

Project Name: Ocean View Church

Sheet Title: Floor Plans - Phases II, III, IV, & V

© COPYRIGHT March 02, 2012 by domesticstudio architecture. All rights reserved. Project: Ocean View Church. Drawing: Ocean View Church - Phases II, III, IV, & V. Rev. 02/12.

SEE SHEET L-2 FOR CONSTRUCTION, PLANTING AND IRRIGATION NOTES & LEGENDS, AND LANDSCAPE ORDINANCE CALCULATIONS

MANAGEMENT SPECIFICATIONS FOR FUEL MANAGEMENT ZONES
 ZONE 1 - THE IRRIGATED DOMESTIC PLANTINGS IN THE PLANT AREAS WITHIN THE PRIVATE PROPERTY LINE, WHICH ARE TO BE MAINTAINED BY THE OWNER.
 ZONE 2 - THE TRANSITIONAL AREA BETWEEN THE IRRIGATED ZONE 1 PLANTINGS AND THE UNDISTURBED NATIVE HABITAT. ZONE 2 IS TYPICALLY EXISTING THINNED, NATIVE OR NATURALIZED NON-IRRIGATED VEGETATION.
 SEE SHEET L-3 FOR BUSH MANAGEMENT REQUIREMENTS AND NOTES

UTILITIES LEGEND
 W - WATER SERVICE
 S - SEWER SERVICE
 JT - JOINT TRENCH - GAS, ELECTRIC
 SD - STORM DRAIN
 WM - PROPOSED WATER METER
 BFP - PROPOSED BACKFLOW PREVENTER
 FH - FIRE HYDRANT

CONSTRUCTION LEGEND

- 1 EXISTING SIDEWALK - TO REMAIN
- 2 EXISTING CURB - TO REMAIN
- 3 EXISTING POURED IN PLACE CONCRETE PLANTER WALL - TO REMAIN, NATURAL GREY W/ SMOOTH FINISH - SEE DETAIL J, L-6
- 4 EXISTING ASPHALT SURFACE - TO REMAIN
- 5 EXISTING CHAIN LINK FENCE - TO REMAIN, HEIGHT PER PLAN - SEE DETAIL K, L-6
- 6 EXISTING SCOREBOARD - TO REMAIN
- 7 PARKING AND DRIVE - PER CIVIL ENGINEER'S PLANS
- 8 TEACHER CLASSROOMS - TO REMAIN
- 9 CONCRETE WALK - NATURAL GREY COLOR, LIGHT BROOM FINISH
- 10 CONCRETE PLAZA PAVEMENT - LIGHT INTEGRAL COLOR, ACID WASH FINISH WITH MEDIUM SANDPLAST ACCENTS AND BANDS
- 11 CONCRETE PAVING - DARK INTEGRAL COLOR - LIGHT EXPOSED AGGREGATE FINISH
- 12 CONCRETE PAVING - DARK INTEGRAL, MEDIUM SANDPLAST FINISH
- 13 FLAGSTONE PAVEMENT
- 14 STONE STEPPERS
- 15 DECOMPOSED GRANITE PATH W/ CONCRETE CURB EDGE
- 16 REDWOOD HEADERS/BOARD
- 17 CONCRETE MOW CURB
- 18 CONCRETE STEPS W/ STEEL HANDRAIL
- 19 CONCRETE RAMP W/ STEEL HANDRAIL
- 20 CONCRETE SEAT WALL - SEE DETAIL A, L-6
- 21 8" MASONRY & STUCCO SCREEN WALL - SEE DETAIL B, L-6
- 22 STUCCO RETAINING WALL - SEE DETAIL C, L-6
- 23 6" HIGH PAINTED TUBE STEEL FENCE - SEE DETAIL D, L-6
- 24 VEGETATED SWALE - SEE CIVIL PLANS
- 25 PAINTED TUBE STEEL GATE - HEIGHT TO MATCH ADJACENT FENCE
- 26 FRESH CONCRETE FOOT
- 27 WOOD BENCH
- 28 BUBBLER / BOWL FOUNTAIN
- 29 BIKE RACK
- 30 PRE-SCHOOL PLAY EQUIPMENT (INCLUDING CLIMBER, PLAYHOUSE, SWINGS, AND RIDERS)
- 31 RUBBERIZED SURFACE PAVEMENT
- 32 CONCRETE PLAY SURFACE
- 33 SAND PLAY AREA
- 34 PAINTED PAVEMENT GAMES
- 35 BUBBLER / BOWL FOUNTAIN
- 36 LAWN PLAY AREA - EXISTING FOOTBALL FIELD
- 37 BASEBALL BACKSTOP FENCE & DUGOUTS
- 38 PICNIC TABLE
- 39 LIGHT BOLLARD
- 40 CONCRETE STEPPERS
- 41 TREE GRATE
- 42 CONCRETE TRICE TRACK
- 43 STEEL DECK OVERLOOK W/ CANYON INTERPRETIVE SIGNAGE
- 44 PROPOSED BUS STOP W/ BENCH SEATING AND TRASH CONTAINER
- 45 BUS STOP/SHEDSHARE INFORMATION SIGN
- 46 PROPOSED CITY SIDEWALK
- 47 DRIVE APRON - PER CIVIL PLANS
- 48 CURB RAMP - PER CIVIL PLANS
- 49 ENTRY SIGN - SEE DETAIL F, L-6
- 50 6" CMU TRASH ENCLOSURE W/ PAINTED STEEL GATES. COLOR & FINISH TO MATCH ADJACENT ARCHITECTURE - SEE DETAIL E, L-6
- 51 EXISTING 5' HIGH WOODEN IRON PLAY AREA FENCE - SEE DETAIL H, L-6
- 52 EXISTING SAND PLAY SURFACE
- 53 EXISTING CHAIN LINK FENCE - TO BE REMOVED
- 54 SOLID WOOD FENCE - SEE DETAIL G, L-6
- 55 PARKING GARAGE SHADE STRUCTURE - PER ARCHITECT'S PLANS
- 56 PARKING GARAGE RETAINING WALL - PER ARCHITECT'S PLANS

STATEMENT OF DESIGN

THE PROPOSED LANDSCAPE UTILIZES A MEDITERRANEAN PLANT PALETTE NATURALLY ADAPTED TO THE CLIMATE OF THE SITE. AREAS ADJACENT TO ENVIRONMENTAL SENSITIVE LANDS UTILIZE A NATIVE PLANT PALETTE. NORTH FACES SLOPES ARE PLANTED WITH A WATER PLANT PALETTE TO FURTHER BLEND THE PROJECT SITE WITH THE ADJACENT OPEN SPACE, TO BLEND WITH AND ACCENTUATE THE ARCHITECTURE. BROAD MASSINGS OF SHRUBS ARE LAYERED ALONG WALLS & WALLS AND ARE ACCENTED BY PERENNIALS AND GRASSES. PLANTINGS WILL BE IRRIGATED WITH A FULLY AUTOMATIC, UNDERGROUND IRRIGATION SYSTEM. THIS SYSTEM WILL USE LOW VOLTAGE EMITTERS TO PREVENT SOIL SALINITY. HEADS, ALONG WITH BUBBLER HEADS AND IN-LINE DRIP ASSOCIATION IN SMALLER AREAS TO CONSERVE WATER. HEADS WILL BE GROUPED INTO ZONES BASED ON EXPOSURE AND PLANT TYPES. AUTOMATIC VALVES WILL CONTROL THE FLOW OF WATER TO EACH ZONE. A SHADY CONTROLLED WITH ROSEHUE ADJUSTED BY ACTUAL LOCAL EVAPORATION DEFICIT (ET) METERS WILL BE USED TO CONTROL THE AUTOMATIC VALVES. AN AUTOMATIC RAIN SENSING OVER-IDE WILL BE CONNECTED TO THE CONTROLLER. INDIVIDUAL HEADS AND ZONES WILL BE ADJUSTED TO MINIMIZE OVERSPRAY ON BUILDINGS, WALLS, WALKS AND PAVEMENTS. A BRUSH MANAGEMENT PLAN WAS PROVIDED TO CREATE A DEFENSIVE SPACE BETWEEN THE WALLS AND PAVEMENTS. A BRUSH MANAGEMENT PLAN WAS PROVIDED TO CREATE A DEFENSIVE SPACE BETWEEN THE WALLS AND PAVEMENTS. A BRUSH MANAGEMENT PLAN WAS PROVIDED TO CREATE A DEFENSIVE SPACE BETWEEN THE WALLS AND PAVEMENTS. A BRUSH MANAGEMENT PLAN WAS PROVIDED TO CREATE A DEFENSIVE SPACE BETWEEN THE WALLS AND PAVEMENTS.

EXISTING TREES & SHRUBS TO REMAIN LEGEND

SYM	BOTANICAL NAME	COMMON NAME	HEIGHT	SPREAD
EC	EUCALYPTUS CITRIGODOKA	LEMON SCENTED GUM	15'-45'	15'-45'
PC	PHINIS CANARIENSIS	CANARY ISLAND PINE	50'-80'	20'-35'
AK	ARECATHURUS ROMANZOFFIANUM	QUEEN PALM	50'	20'-25'
AR	ARCHONIA PHOENIX CUNNINGHAMIANA	KING PALM	50'	10'-15'
F	PHOENIX CANARIENSIS	CANARY ISLAND DATE PALM	60'	20'-50'
FR	PHOENIX ROSEBELLE	PYGMY DATE PALM	6'-12'	6'-8'
C	CUPRANOPSIS ANACARDIODES	CARDONWOOD	40'	30'
K	KOELREUTERIA BIPINNATA	CHINESE FLAME TREE	20'-40'	20'-40'
G	CYPRESSUS SEMPERVERIBUS	ITALIAN CYPRESS	15'-10'	15'-10'
CR	CYCAS REVOLUTA	SAGO PALM	3'-10'	3'-10'
J	JACARANDA MIMOSIFOLIA	JACARANDA	25'-40'	15'-30'
CB	CARPOROTUS CHILENSIS	ICE PLANT		GROUND COVER

REVISIONS BY
 2305 EL CIPRIANO RD.
 SAN DIEGO, CA 92104
 TEL. 619.294.9424
 FAX. 619.294.9828
 www.dpa.com

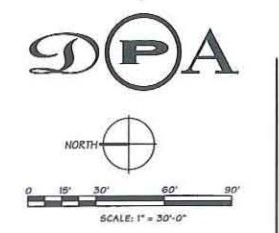

THIS PLAN IS CONCEPTUAL AND SCHEMATIC IN NATURE ONLY. IT IS NOT INTENDED TO BE A FINAL CONSTRUCTION PLAN. THIS PLAN DOES NOT SHOW FINAL CONSTRUCTION DETAILS, STRUCTURAL OR DRAINAGE REQUIREMENTS, FINAL PLANTING LOCATIONS, OR IRRIGATION DESIGN. ADDITIONAL DETAIL MUST BE DEVELOPED IN THESE AREAS PRIOR TO CONSTRUCTION. DPA INC. ASSUMES NO LIABILITY FOR CONSTRUCTION PURSUANT TO THIS PLAN.

**CONCEPTUAL LANDSCAPE PLAN
 OCEAN VIEW BAPTIST CHURCH
 SAN DIEGO, CALIFORNIA**

DATE: 2/24/13
 SCALE: 1"=30'-0"
 DRAWN: HGB
 JOB NO.: 084037
 SHEET: L-1
 OF: 1 SHEETS

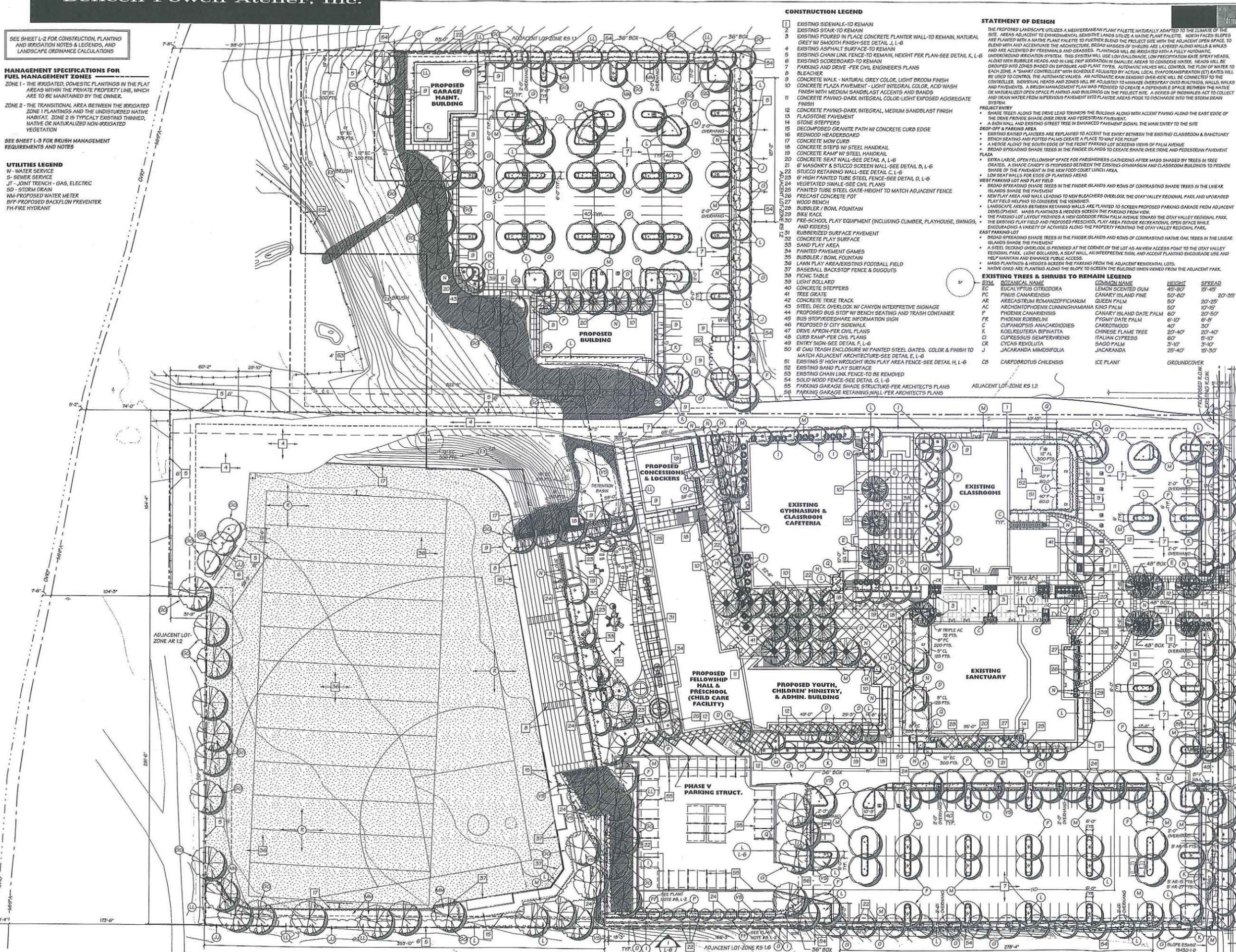

Copyright © March 15, 2011 by d4studio. All rights reserved. This drawing is the property of d4studio architecture. All other trademarks and registered trademarks are the property of their respective owners. All dimensions are in feet and inches unless otherwise noted.

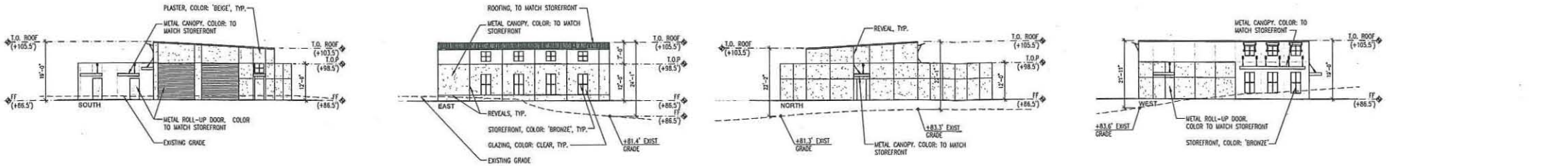

Garage / Maintenance Building
1/16" = 1'-0"

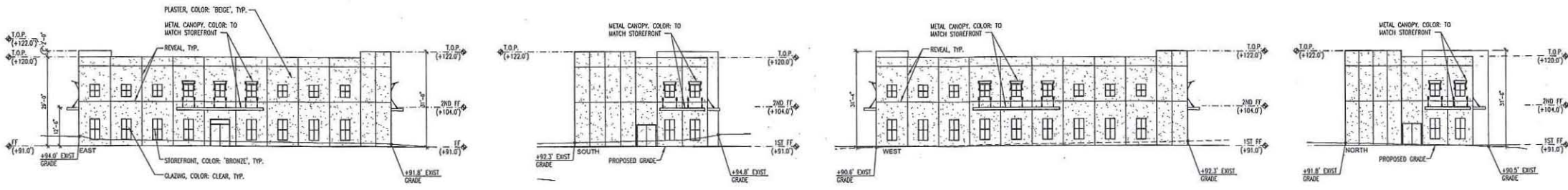

Multi-Purpose Room
1/16" = 1'-0"

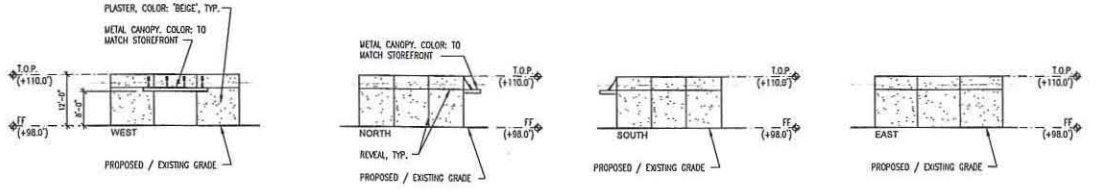

Restroom Building
1/16" = 1'-0"

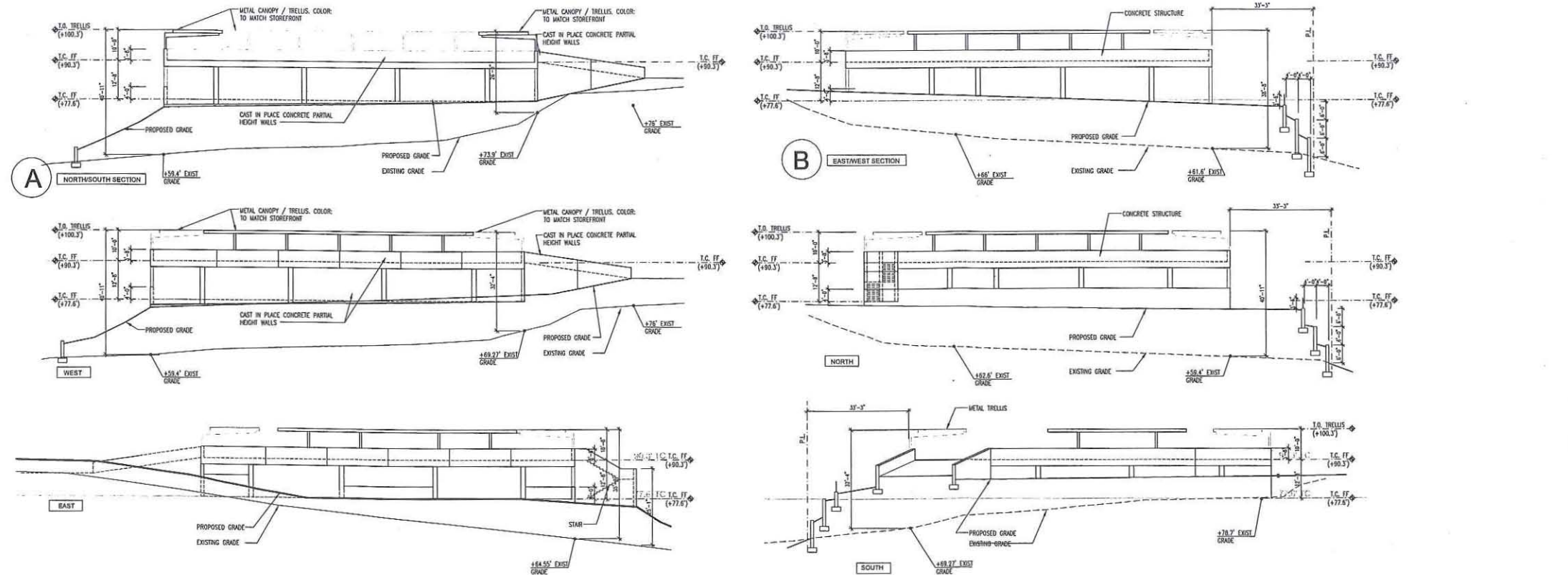

Parking Structure - Elevations and Sections
1/16" = 1'-0"

Contact: d4studio architecture
 JOHN PYJAR
 Address: 2150 W. WASHINGTON ST., STE. 303
 SAN DIEGO, CA 92110
 Phone/Fax: TEL: 619-492-9393 EXT. 14
 FAX: 619-492-9394
 Project Address: 2400 PALM AVE
 SAN DIEGO, CALIFORNIA 92154
 A.P.N. 628-050-47-00; 628-050-57-00; 628-050-48-00

d4studio architecture
 2185 West Viewmont, Ste 203
 San Diego, California 92110
 Tel: 619-492-9393
 Fax: 619-492-9394
 d4studio.com

Project:
 C.U.P. Completion Rev. February 2, 2010
 C.U.P. Submittal #1 March 13, 2010
 C.U.P. Submittal #2 October 7, 2010
 C.U.P. Submittal #3 April 18, 2011
 C.U.P. Submittal #4 May 31, 2011
 C.U.P. Submittal #5 Dec. 15, 2011
 Revision March 2, 2011

Project Name: **Ocean View Church**
 Sheet Title: **Site / Building Elevations**

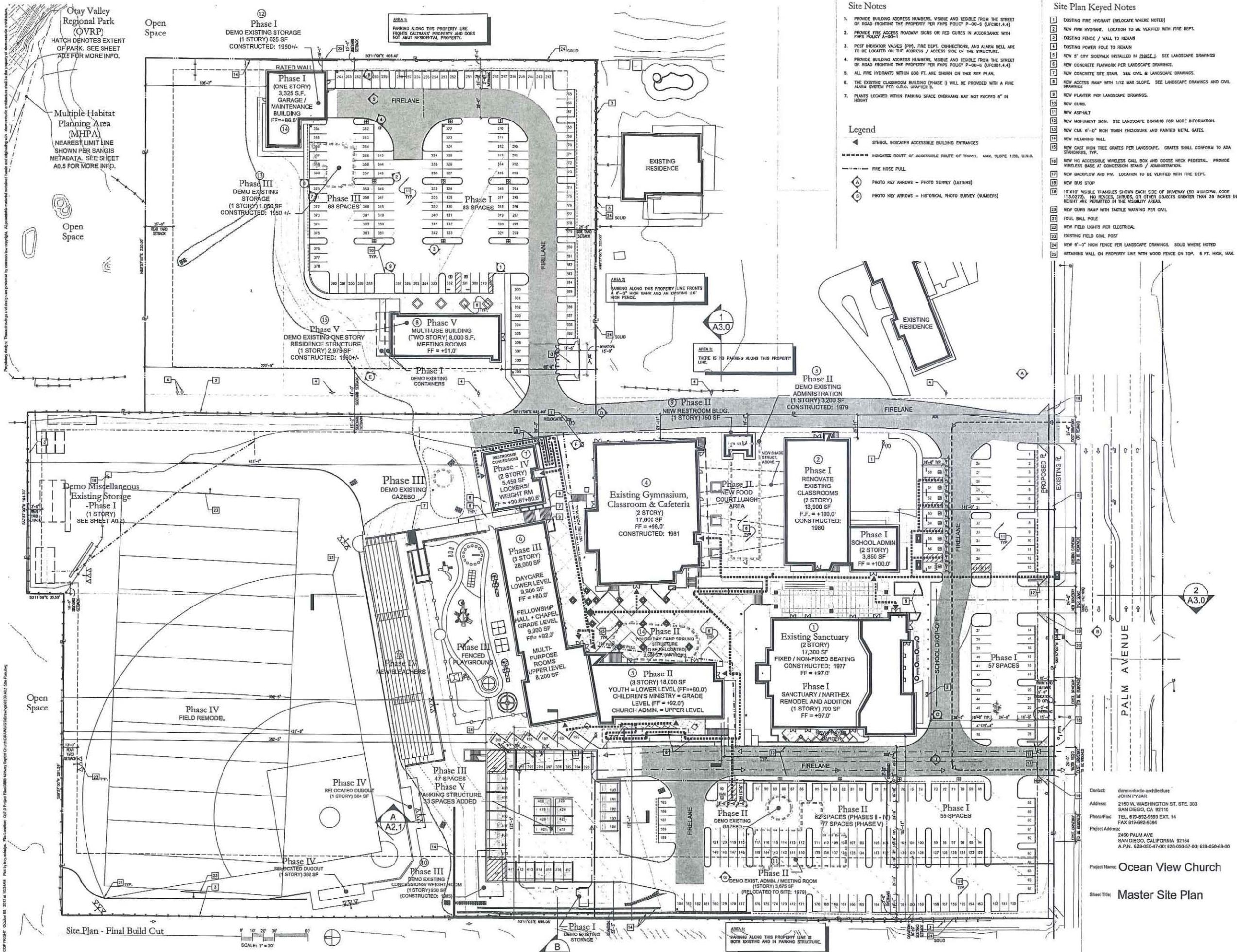

Site Notes

1. PROVIDE BUILDING ADDRESS NUMBERS, VISIBLE AND LEGIBLE FROM THE STREET OR ROAD FRONTING THE PROPERTY PER PHPS POLICY P-00-8 (UCF01.4.4)
2. PROVIDE FIRE ACCESS ROADWAY SIGNS OR RED CURBS IN ACCORDANCE WITH PHPS POLICY A-00-1
3. POST INDICATOR VALVES (PIV), FIRE DEPT. CONNECTIONS, AND ALARM BELL ARE TO BE LOCATED ON THE ADDRESS / ACCESS SIDE OF THE STRUCTURE.
4. PROVIDE BUILDING ADDRESS NUMBERS, VISIBLE AND LEGIBLE FROM THE STREET OR ROAD FRONTING THE PROPERTY PER PHPS POLICY P-00-8 (UCF01.4.4)
5. ALL FIRE HYDRANTS WITHIN 600 FT. ARE SHOWN ON THIS SITE PLAN.
6. THE EXISTING CLASSROOM BUILDING (PHASE 9) WILL BE PROVIDED WITH A FIRE ALARM SYSTEM PER C.B.C. CHAPTER 9.
7. PLANTS LOCATED WITHIN PARKING SPACE OVERHANG MAY NOT EXCEED 6" IN HEIGHT

Legend

- SYMBOL INDICATES ACCESSIBLE BUILDING ENTRANCES
- INDICATES ROUTE OF ACCESSIBLE ROUTE OF TRAVEL. MAX. SLOPE 1:20, U.N.D.
- FIRE HOSE PULL
- PHOTO KEY ARROWS - PHOTO SURVEY (LETTERS)
- PHOTO KEY ARROWS - HISTORICAL PHOTO SURVEY (NUMBERS)

Site Plan Keyed Notes

- EXISTING FIRE HYDRANT (RELOCATE WHERE NOTED)
- NEW FIRE HYDRANT. LOCATION TO BE VERIFIED WITH FIRE DEPT.
- EXISTING FENCE / WALL TO REMAIN
- EXISTING POWER POLE TO REMAIN
- NEW 5" CITY SIDEWALK INSTALLED IN PHASE 1. SEE LANDSCAPE DRAWINGS
- NEW CONCRETE PLATWORK PER LANDSCAPE DRAWINGS.
- NEW CONCRETE SITE STAIR. SEE CIVIL & LANDSCAPE DRAWINGS.
- NEW ACCESS RAMP WITH 1:12 MAX SLOPE. SEE LANDSCAPE DRAWINGS AND CIVIL DRAWINGS
- NEW PLANTER PER LANDSCAPE DRAWINGS.
- NEW CURB.
- NEW ASPHALT
- NEW MONUMENT SIGN. SEE LANDSCAPE DRAWING FOR MORE INFORMATION.
- NEW CMU 6"-0" HIGH TRASH ENCLOSURE AND PAINTED METAL GATES.
- NEW RETAINING WALL.
- NEW CAST IRON TREE GRATES PER LANDSCAPE. GRATES SHALL CONFORM TO ADA STANDARDS, TYP.
- NEW HIGH ACCESSIBLE WIRELESS CALL BOX AND GOOSE NECK PEDESTAL. PROVIDE WIRELESS BASE AT CONCESSION STAND / ADMINISTRATION.
- NEW BACKFLOW AND PIV. LOCATION TO BE VERIFIED WITH FIRE DEPT.
- NEW BUS STOP
- 10"x10" VISIBLE TRIANGLES SHOWN EACH SIDE OF DRIVEWAY (80 MUNICIPAL CODE 113.07.01). NO FENCES, BARRIERS, OR OTHER OBJECTS GREATER THAN 36 INCHES IN HEIGHT ARE PERMITTED IN THE VISIBILITY AREAS.
- NEW CURB RAMP WITH TACTILE WARNING PER CML
- FOUL BALL POLE
- NEW FIELD LIGHTS PER ELECTRICAL
- EXISTING FIELD GOAL POST
- NEW 6'-0" HIGH FENCE PER LANDSCAPE DRAWINGS. SOLID WHERE NOTED
- RETAINING WALL ON PROPERTY LINE WITH WOOD FENCE ON TOP. 6 FT. HIGH, MAX.

Otay Valley Regional Park (OVRP)
HATCH DENOTES EXTENT OF PARK. SEE SHEET A0.5 FOR MORE INFO.

Multiple-Habitat Planning Area (MHPA)
NEAREST LIMIT LINE SHOWN PER SANGIS METADATA. SEE SHEET A0.5 FOR MORE INFO.

Open Space

Site Plan - Final Build Out

SCALE: 1" = 30'

© Copyright © October 18, 2011 by ddmstudio. All rights reserved. No part of this document may be reproduced without the written permission of ddmstudio. The location of the project is shown on the map. All trademarks and registered trademarks are the property of their respective owners.

Ocean View Baptist
San Diego, California

Master Site Plan

Contact: domusstudio architecture
JOHN PYJARR
Address: 2150 W. WASHINGTON ST., STE. 303
SAN DIEGO, CA 92110
Phone/Fax: TEL 619-692-9335 EXT. 14
FAX 619-692-9394
Project Address: 2460 PALM AVE
SAN DIEGO, CALIFORNIA 92154
A.P.N. 628-050-47-00; 628-050-57-00; 628-050-68-00

Project Name: Ocean View Church
Sheet Title: Master Site Plan

Project:
C.U.P. Completion Rev: February 2, 2010
C.U.P. Submittal #1: March 13, 2010
C.U.P. Submittal #2: October 7, 2010
C.U.P. Submittal #3: April 18, 2011
C.U.P. Submittal #4: May 21, 2011
C.U.P. Submittal #5: Dec. 15, 2011
Revisions:

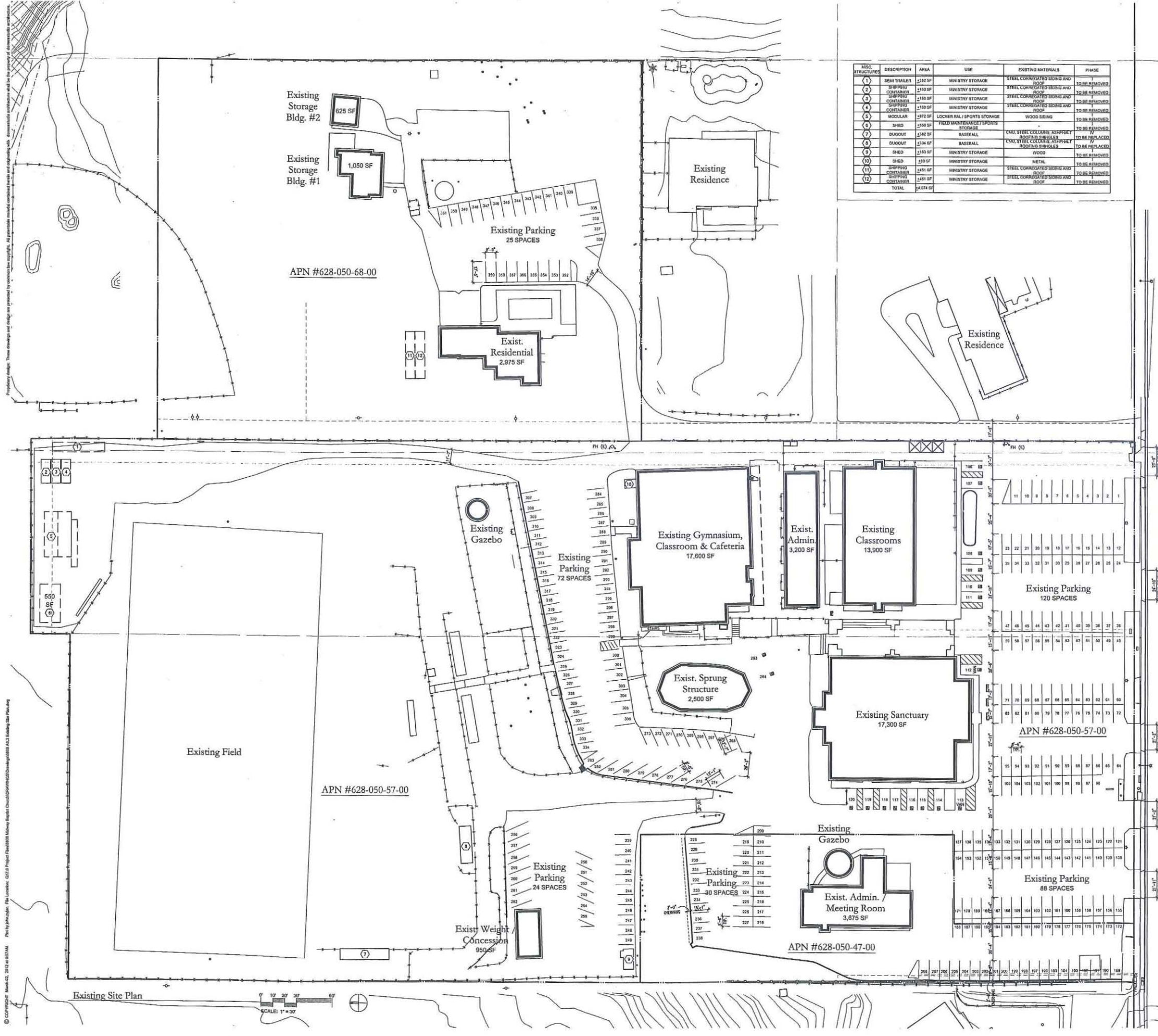

MISC STRUCTURE	DESCRIPTION	AREA	USE	EXISTING MATERIALS	PHASE
1	SEMI TRAILER	252 SF	MINISTRY STORAGE	STEEL CORUGATED IRON AND ROOF	TO BE REMOVED
2	SHIPPING CONTAINER	1760 SF	MINISTRY STORAGE	STEEL CORUGATED IRON AND ROOF	TO BE REMOVED
3	SHIPPING CONTAINER	1760 SF	MINISTRY STORAGE	STEEL CORUGATED IRON AND ROOF	TO BE REMOVED
4	SHIPPING CONTAINER	1760 SF	MINISTRY STORAGE	STEEL CORUGATED IRON AND ROOF	TO BE REMOVED
5	SHIPPING CONTAINER	1760 SF	MINISTRY STORAGE	STEEL CORUGATED IRON AND ROOF	TO BE REMOVED
6	SHED	1872 SF	LOCKER BIL / SPORTS STORAGE	WOOD SIDING	TO BE REMOVED
7	SHED	2500 SF	FIELD MAINTENANCE / SPORTS STORAGE	WOOD SIDING	TO BE REMOVED
8	DISCOUT	2342 SF	BASEBALL	CHARL STEEL COLUMN, ASPHALT ROOFING SHINGLES	TO BE REPLACED
9	DISCOUT	2304 SF	BASEBALL	CHARL STEEL COLUMN, ASPHALT ROOFING SHINGLES	TO BE REPLACED
10	SHED	2343 SF	MINISTRY STORAGE	WOOD	TO BE REMOVED
11	SHED	283 SF	MINISTRY STORAGE	METAL	TO BE REMOVED
12	SHIPPING CONTAINER	2441 SF	MINISTRY STORAGE	STEEL CORUGATED IRON AND ROOF	TO BE REMOVED
13	SHIPPING CONTAINER	2441 SF	MINISTRY STORAGE	STEEL CORUGATED IRON AND ROOF	TO BE REMOVED
TOTAL		24,874 SF			

Contact: domusstudio architecture
 JOHN PYLAR
 Address: 2150 W. WASHINGTON ST. STE. 303
 SAN DIEGO, CA 92110
 Phone/Fax: TEL. 619-692-9393 EXT. 14
 FAX 619-692-9394
 domusstudio
 Project Address: 2460 PALM AVE
 SAN DIEGO, CALIFORNIA 92154
 A.P.N. 628-050-47-00; 628-050-67-00; 628-050-68-00

Project Name: Ocean View Church
 Sheet Title: Existing Site Plan

domusstudio architecture
 2150 W. WASHINGTON ST. STE. 303
 SAN DIEGO, CALIFORNIA 92110
 TEL 619 692 9393
 FAX 619 692 9394
 domusstudio
 Project: C.U.P. Completion Res February 2, 2010
 C.U.P. Submittal #1 March 13, 2010
 C.U.P. Submittal #2 October 7, 2010
 C.U.P. Submittal #3 April 18, 2011
 C.U.P. Submittal #4 May 21, 2011
 C.U.P. Submittal #5 Dec. 18, 2011

Copyright © 2011 by domusstudio architecture. All rights reserved. This drawing is the property of domusstudio architecture and is not to be reproduced, stored in a retrieval system, or transmitted in any form or by any means, electronic, mechanical, photocopying, recording, or by any information storage and retrieval system, without the prior written permission of domusstudio architecture.

**OTAY MESA-NESTOR COMMUNITY PLANNING GROUP
MEETING MINUTES
11 May 2011**

Members Present:

Dist. 1 John Swanson
Dist. 3 Ed Abraham
Dist. 4 Diane Porter
Dist. 7 Ira Briggs
Dist. 8 Myrna Briggs
Dist. 10 Bob Mikloski
Dist. 11 Albert Velasquez
Dist. 12 Carlos Sanchez
Dist. 13 Daniel Wagner

Dist. 14 Wayne Dickey
Dist. 16 Steve Schroeder

Members Absent:

Dist. 2 Sam Mendoza
Dist. 6 Maria Mendoza
Dist. 15 Walt Zumstein

Vacant Chairs:

Dist. 5
Dist. 9

Guests Present:

Rosey Gambie, guest
Coralie Zumstein, resident
Kenneth Colwell, resident
Dan Malcom, resident
Kim Gelardi, guest

Tom Olmstead, guest
Yobany Chacon, guest
Edrei Alas, guest
Mike Stames, guest
Vivian Moreno, guest

Alan Zavalefe, Guest
Joe Luzon, guest
Ezequiel Rivas, guest
Areli Perez, guest

1. **Call to Order/Introduction of Members:** The meeting was called to order at 6:33 p.m. by Daniel Wagner, Chairman, at the Otay Mesa Branch Library. He welcomed all Board members and the community to the meeting of the Otay Mesa-Nestor Community Planning Group (OMNCPG).
2. **Approval of minutes** – Motion made by Bob Mikloski to approve the minutes of the April 13, 2010, OMNCPG meeting, and the motion was passed unanimously.
3. **Non-Agenda Public Comments:** None
4. **SDPD Community Relations:** Officer LaCarra's phone number is 619-424-0440, and his email address is: clacarra@pd.sandiego.gov
 - a. Officer LaCarra said that a South Bay apartment house managers training meeting will be held July 20, 2011, from 8am to 5pm at the Willow Elementary School, 226 Willow Rd., San Ysidro, CA. The RSVP is to Officer Ray Ramirez, 619-623-3751 X 104.
 - b. He also said that there have been a string of burglaries in the area which are being investigated. On May 7, 2011, a burglary suspect was arrested.
5. **40th Senate District Report:** No report.
6. **Council District 8 Report:** Vivian Moreno, Council Representative for the District 8 Councilmember David Alvarez, was in attendance. She can be reached at 619-533-6394, and her email is VMoreno@sandiego.gov
 - a. She handed out a District 8 update report.
 - b. She also announced that a number of vacancies exist on various City of San Diego Boards and Commissions. The contact information was placed in the handout.
 - c. She announced several events to be held in South Bay, and details about these funds are the handout.

7. **Action item: Project No. 230707, Community Church, 635 Beyer Way.** Applicant is requesting a **Conditional Use Permit** for a religious facility at this location.
- a. Myrna Briggs, chair of the OMNCPG Project Development Review sub-committee, said that they had reviewed this plan in detail, and recommended approval to the planning group.
 - b. The applicant had addressed concerns about off-street parking.

Motion to approve made by John Swanson, seconded by Bob Mikloski:

Voting results: 10 – 1 - 0, 1 abstention (Wayne Dickey). Motion carries.

8. **Action item: Project No. 205163, Ocean View Church, 2460 Palm Ave.** Applicant is requesting an **amendment to their Conditional Use Permit** accompanied with a Stakeholder Dan Malcom and architect Mike Stames presented an application for an amendment of their CUP for this church to the OMNCPG:
- a. Myrna Briggs, chair of the OMNCPG Project Development Review sub-committee, said that they had reviewed this plan in detail, and recommended approval to the planning group.
 - b. The applicant had addressed concerns about the steeple exceeding the height limit, and the City of San Diego staff found that the overall project plan is appropriate.

Motion to approve made by Bob Mikloski, seconded by John Swanson:

Voting results: 11 – 0 - 0. Motion carries.

9. **Sub-Committee Reports:**
- a. Myrna Briggs, chair of the OMNCPG Project Development Review sub-committee, said that they had reviewed:
 - 1.The above mentioned Ocean View church plan; and
 - 2.The Community Church plan in detail.
 - 3.The sub-committee recommended approval of both plans to the planning group.
10. **Chair's Report:** None.
11. **Long Range City Planner's Report:** No report.
12. **Adjournment:** 7:27 p.m.

Respectively submitted by John C. Swanson, Secretary

**The next meeting is June 8, 2011, at 6:30 p.m., at the
Otay Mesa/Nestor Branch Library.**

ATTACHMENT 10



City of San Diego
 Development Services
 1222 First Ave., MS-302
 San Diego, CA 92101
 (619) 446-5000

Ownership Disclosure Statement

Approval Type: Check appropriate box for type of approval (s) requested: Neighborhood Use Permit Coastal Development Permit
 Neighborhood Development Permit Site Development Permit Planned Development Permit Conditional Use Permit
 Variance Tentative Map Vesting Tentative Map Map Waiver Land Use Plan Amendment Other _____

Project Title: Midway Baptist Church CUP Project No. For City Use Only: 205163

Project Address: 2460 PALM AVE
SAN DIEGO CA

Part I - To be completed when property is held by Individual(s)

By signing the Ownership Disclosure Statement, the owner(s) acknowledge that an application for a permit, map or other matter, as identified above, will be filed with the City of San Diego on the subject property, with the intent to record an encumbrance against the property. Please list below the owner(s) and tenant(s) (if applicable) of the above referenced property. The list must include the names and addresses of all persons who have an interest in the property, recorded or otherwise, and state the type of property interest (e.g., tenants who will benefit from the permit, all individuals who own the property). A signature is required of at least one of the property owners. Attach additional pages if needed. A signature from the Assistant Executive Director of the San Diego Redevelopment Agency shall be required for all project parcels for which a Disposition and Development Agreement (DDA) has been approved / executed by the City Council. Note: The applicant is responsible for notifying the Project Manager of any changes in ownership during the time the application is being processed or considered. Changes in ownership are to be given to the Project Manager at least thirty days prior to any public hearing on the subject property. Failure to provide accurate and current ownership information could result in a delay in the hearing process.

Additional pages attached Yes No

Name of Individual (type or print): _____

Owner Tenant/Lessee Redevelopment Agency

Street Address: _____

City/State/Zip: _____

Phone No: _____ Fax No: _____

Signature: _____ Date: _____

Name of Individual (type or print): _____

Owner Tenant/Lessee Redevelopment Agency

Street Address: _____

City/State/Zip: _____

Phone No: _____ Fax No: _____

Signature: _____ Date: _____

Name of Individual (type or print): _____

Owner Tenant/Lessee Redevelopment Agency

Street Address: _____

City/State/Zip: _____

Phone No: _____ Fax No: _____

Signature: _____ Date: _____

Name of Individual (type or print): _____

Owner Tenant/Lessee Redevelopment Agency

Street Address: _____

City/State/Zip: _____

Phone No: _____ Fax No: _____

Signature: _____ Date: _____

Project Title:

Midway Baptist Church CUP

Project No. (For City Use Only)

Part II - To be completed when property is held by a corporation or partnership

Legal Status (please check):

[X] Corporation [] Limited Liability -or- [] General) What State? CA Corporate Identification No. 232957
[] Partnership

By signing the Ownership Disclosure Statement, the owner(s) acknowledge that an application for a permit, map or other matter, as identified above, will be filed with the City of San Diego on the subject property with the intent to record an encumbrance against the property. Please list below the names, titles and addresses of all persons who have an interest in the property, recorded or otherwise, and state the type of property interest (e.g., tenants who will benefit from the permit, all corporate officers, and all partners in a partnership who own the property). A signature is required of at least one of the corporate officers or partners who own the property. Attach additional pages if needed. Note: The applicant is responsible for notifying the Project Manager of any changes in ownership during the time the application is being processed or considered. Changes in ownership are to be given to the Project Manager at least thirty days prior to any public hearing on the subject property. Failure to provide accurate and current ownership information could result in a delay in the hearing process. Additional pages attached [] Yes [X] No

Corporate/Partnership Name (type or print): MIDWAY BAPTIST CHURCH
[X] Owner [] Tenant/Lessee
Street Address: 2460 Palm Ave
City/State/Zip: SAN DIEGO CA 619-424-5615
Phone No: 619-424-7870 Fax No:
Name of Corporate Officer/Partner (type or print): Jim Baize, President
Title (type or print): PRESIDENT
Signature: [Signature] Date: 2/10/10

Corporate/Partnership Name (type or print):
[] Owner [] Tenant/Lessee
Street Address:
City/State/Zip:
Phone No: Fax No:
Name of Corporate Officer/Partner (type or print):
Title (type or print):
Signature : Date:

Corporate/Partnership Name (type or print):
[] Owner [] Tenant/Lessee
Street Address:
City/State/Zip:
Phone No: Fax No:
Name of Corporate Officer/Partner (type or print):
Title (type or print):
Signature : Date:

Corporate/Partnership Name (type or print): Midway Baptist Church
[X] Owner [] Tenant/Lessee
Street Address: 2460 Palm Avenue
City/State/Zip: San Diego, CA 92154 619-424-5615
Phone No: 619-424-7870 Fax No:
Name of Corporate Officer/Partner (type or print): Donna Kline
Title (type or print): Secretary
Signature: [Signature] Date: 2/10/10

Corporate/Partnership Name (type or print):
[] Owner [] Tenant/Lessee
Street Address:
City/State/Zip:
Phone No: Fax No:
Name of Corporate Officer/Partner (type or print):
Title (type or print):
Signature : Date:

Corporate/Partnership Name (type or print):
[] Owner [] Tenant/Lessee
Street Address:
City/State/Zip:
Phone No: Fax No:
Name of Corporate Officer/Partner (type or print):
Title (type or print):
Signature : Date:



Mail Processing Center
 Federal Aviation Administration
 Southwest Regional Office
 Obstruction Evaluation Group
 2601 Meacham Boulevard
 Fort Worth, TX 76137

ATTACHMENT 11

Aeronautical Study No.
 2012-AWP-517-OE
 Prior Study No.
 2010-AWP-4297-OE

Issued Date: 02/08/2012

john pyjar
 domusstudio architecture
 2150 w. washington
 #303
 San Diego, CA 92110

**** DETERMINATION OF NO HAZARD TO AIR NAVIGATION ****

The Federal Aviation Administration has conducted an aeronautical study under the provisions of 49 U.S.C., Section 44718 and if applicable Title 14 of the Code of Federal Regulations, part 77, concerning:

Structure: Tower Ocean View Church
 Location: San Diego, CA
 Latitude: 32-35-03.84N NAD 83
 Longitude: 117-04-49.09W
 Heights: 96 feet site elevation (SE)
 61 feet above ground level (AGL)
 157 feet above mean sea level (AMSL)

This aeronautical study revealed that the structure does not exceed obstruction standards and would not be a hazard to air navigation provided the following condition(s), if any, is(are) met:

It is required that FAA Form 7460-2, Notice of Actual Construction or Alteration, be completed and returned to this office any time the project is abandoned or:

- At least 10 days prior to start of construction (7460-2, Part I)
- Within 5 days after the construction reaches its greatest height (7460-2, Part II)

Based on this evaluation, marking and lighting are not necessary for aviation safety. However, if marking/lighting are accomplished on a voluntary basis, we recommend it be installed and maintained in accordance with FAA Advisory circular 70/7460-1 K Change 2.

This determination expires on 08/08/2013 unless:

- (a) extended, revised or terminated by the issuing office.
- (b) the construction is subject to the licensing authority of the Federal Communications Commission (FCC) and an application for a construction permit has been filed, as required by the FCC, within 6 months of the date of this determination. In such case, the determination expires on the date prescribed by the FCC for completion of construction, or the date the FCC denies the application.

NOTE: REQUEST FOR EXTENSION OF THE EFFECTIVE PERIOD OF THIS DETERMINATION MUST BE E-FILED AT LEAST 15 DAYS PRIOR TO THE EXPIRATION DATE. AFTER RE-EVALUATION OF CURRENT OPERATIONS IN THE AREA OF THE STRUCTURE TO DETERMINE THAT NO SIGNIFICANT AERONAUTICAL CHANGES HAVE OCCURRED, YOUR DETERMINATION MAY BE ELIGIBLE FOR ONE EXTENSION OF THE EFFECTIVE PERIOD.

This determination is based, in part, on the foregoing description which includes specific coordinates , heights, frequency(ies) and power . Any changes in coordinates , heights, and frequencies or use of greater power will void this determination. Any future construction or alteration , including increase to heights, power, or the addition of other transmitters, requires separate notice to the FAA.

This determination does include temporary construction equipment such as cranes, derricks, etc., which may be used during actual construction of the structure. However, this equipment shall not exceed the overall heights as indicated above. Equipment which has a height greater than the studied structure requires separate notice to the FAA.

This determination concerns the effect of this structure on the safe and efficient use of navigable airspace by aircraft and does not relieve the sponsor of compliance responsibilities relating to any law, ordinance, or regulation of any Federal, State, or local government body.

Any failure or malfunction that lasts more than thirty (30) minutes and affects a top light or flashing obstruction light, regardless of its position, should be reported immediately to (877) 487-6867 so a Notice to Airmen (NOTAM) can be issued. As soon as the normal operation is restored, notify the same number.

A copy of this determination will be forwarded to the Federal Communications Commission (FCC) because the structure is subject to their licensing authority.

If we can be of further assistance, please contact our office at (817) 321-7760. On any future correspondence concerning this matter, please refer to Aeronautical Study Number 2012-AWP-517-OE.

Signature Control No: 157508465-158608257
Joan Tengowski
Technician

(DNE)

Attachment(s)
Map(s)

cc: FCC

TOPO Map for ASN 2012-AWP-517-OE

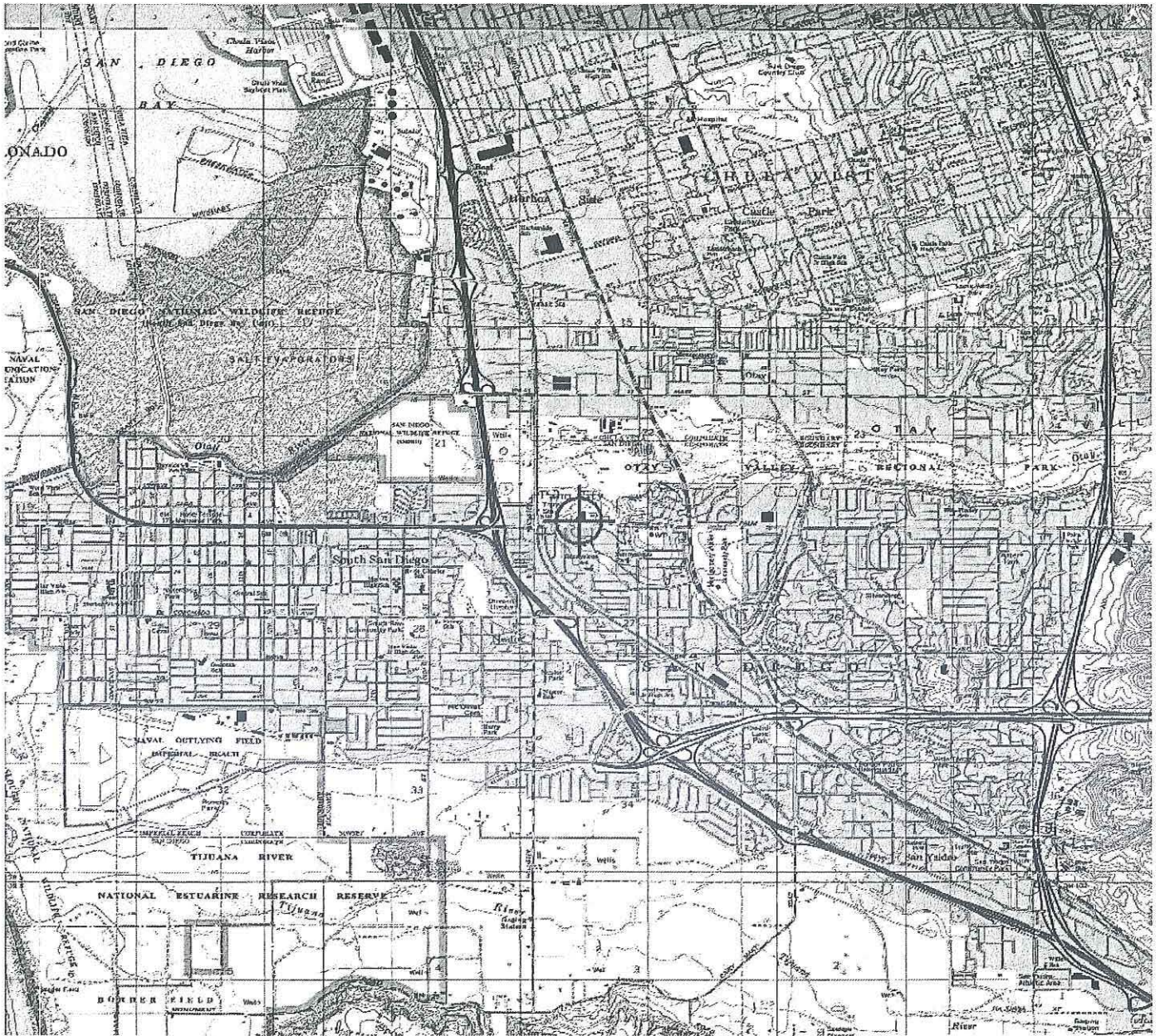

SAN DIEGO COUNTY
REGIONAL AIRPORT AUTHORITY

P.O. BOX 82776, SAN DIEGO, CA 92138-2776
619.400.2400 WWW.SAN.ORG

December 2, 2010

Ms Renee Mezo
City of San Diego
Department of Development Services
1222 First Avenue MS 501
San Diego, California 92101

Re: Airport Land Use Commission Determination
Construction of expansions to existing religious assembly facility
2460 Palm Avenue; APN 625-050-47, -57 & -68

Dear Ms Mezo:

As the Airport Land Use Commission (ALUC) for San Diego County, the San Diego County Regional Airport Authority acknowledges receipt of an application for a determination of consistency for the project described above. This project is located within Review Area 2 of the Airport Influence Area (AIA) for the Brown Field Municipal Airport – Airport Land Use Compatibility Plan (ALUCP).

ALUC staff review of the project description in the application and accompanying plans indicates that the project would construct expansions to an existing religious assembly facility, and a determination of no hazard to air navigation has been secured from the Federal Aviation Administration. Additionally, the property on which the project is proposed does not require the recordation of an overflight notification or an aviation easement to the airport operator. Based upon these facts and the information in the application, a determination of consistency with the ALUCP by the ALUC is not required.

Please contact me at (619) 400-2244 or egowens@san.org should you have any questions.

Sincerely,



Ed Gowens
Land Use Planner
Airport Planning

cc: Amy Gonzalez, SDCRAA, Director, Counsel Services
Tait Galloway, City of San Diego City Planning & Community Investment Department



SAN DIEGO
INTERNATIONAL
AIRPORT