

APPENDIX G-1

Drainage Report

*Drainage Study
for the Otay Mesa
Community Plan Update*

April, 2007

Prepared for:
MNA Consulting
427 C Street, Suite 308
San Diego CA 92101

Prepared by:
Kimley-Horn and Associates, Inc.
517 Fourth Avenue, Suite 301
San Diego CA 92101

Drainage Study For The Otay Mesa Community Plan Update

April, 2007



Chuck Spinks Exp. Date 03/31/08

R.C.E. 30894

TABLE OF CONTENTS

I. BACKGROUND.....	1
II. EXISTING DRAINAGE FACILITIES.....	3
III. HYDROLOGIC ANALYSIS	5
IV. HYDRAULIC ANALYSIS.....	9
V. PROPOSED DRAINAGE FACILITIES.....	12
VI. PROPOSED DRAINAGE ALTERNATIVES	14
VII. RECOMMENDED DRAINAGE DESIGN CRITERIA.....	20
VIII. STORM WATER QUALITY REQUIREMENTS.....	21

LIST OF EXHIBITS

EXISTING DRAINAGE FACILITIES MAP.....	4
WATERSHED MAP	7
AES SUMMARY TABLE	8
HEC-RAS MODEL	10
PROPOSED DRAINAGE FACILITIES MAP	13
COST ESTIMATE	16
PRELIMINARY DESIGN PLAN: LA MEDIA CHANNEL AND BORDER DETENTION BASIN	17
PRELIMINARY DESIGN: CHANNEL CROSS SECTION	18
PROPERTY OWNERSHIP MAP.....	19
RECOMMENDED STORM WATER POLICIES	23
EXAMPLE OF PERMANENT STORM WATER BEST MANAGEMENT PRACTICES	24
STORM WATER REQUIREMENTS CHECKLIST	25

APPENDICES

APPENDIX A	AES HYDROLOGY CALCULATIONS
APPENDIX B	HEC-1 MODEL

I. BACKGROUND

This report has been prepared as an appendix to the Otay Mesa Community Plan update EIR. Its purpose is to provide a summary of the existing drainage situation and facilities and proposed future facilities, including alternatives for draining the large central watershed. In addition, this report presents recommendations for drainage design criteria and storm water quality requirements for each of the watersheds on the Mesa. A detailed pre-design report to be approved by the City of San Diego will be required before initiating the design.

For most of its early history, Otay Mesa was used for agriculture and farming was the primary land use. As industrial and commercial development started taking place in the 1960s, the City of San Diego recognized the need for a comprehensive drainage Master Plan for the Mesa. Because most of the Mesa drains to the South into Mexico, there was concern that the new development would increase the runoff crossing the border. The City needed to establish criteria for the new development such that there was no increase in runoff as a result of the new construction.

In May of 1987, the City Council approved a contract to prepare the Otay Mesa Drainage Master Plan. In August of 1987, the City published a Notice to “All Private Engineers” that established “Drainage Requirements for Development in Otay Mesa” (attached). The Master Plan was published in January, 1988, and included a proposed concrete Channel from Airway Road to Siempre Viva Road that followed the existing drainage channel.

The Master Plan was updated with the “Otay Mesa Drainage Study” published in August, 1999. The most significant recommendation change was moving the proposed new channel from the creek alignment to a new location directly adjacent to La Media Road and Siempre Viva Road. This report utilizes the hydrologic models and analyses prepared for the 1999 Master Plan.

Reproduction of 1987 NOTICE from Engineering and Development Department

NOTICE

Date: August 7, 1987

To: All Private Engineers

From: Subdivision Engineer

Subject: Drainage requirements for development in Otay Mesa

In order to minimize the effects of increased storm water runoff in Mexico, due to development of property in Otay Mesa, all property in Otay Mesa that is within the water shed that drains into Mexico, shall be developed with the following requirements:

1. Each property owner shall provide storm water detention facilities so that there will be no increase in the rate of runoff due to development of the property.
2. The detention facilities shall be designed so that the rate of runoff from the property will not be greater after development than it was before development for a 5 year, 10 year, 25 year and 50 year storm.
3. All drainage facilities crossing four-lane major or higher classification streets shall be designed for a Q100 (existing). Other facilities, except the major channel referred to in paragraph 5, may be designed for Q50 (existing).
4. The Drainage Design Manual shall be used as guidelines for design of drainage facilities and computing design discharges.
5. The City Engineer's Office, Flood Control Section, is preparing a preliminary plan for the main north-south channel from Otay Mesa Road near La Media to the Mexican Border. The preliminary design will include the design "Q" (Q100 existing), the invert grade, and the water surface elevation at the major road crossings.

C.R. Lockhead
Subdivision Engineer

II. EXISTING DRAINAGE FACILITIES

Information was collected for existing drainage and flood control facilities on Otay Mesa through as-built plans, SanGIS maps, and site visits. Most of the existing drainage facilities were constructed as part of the private development that is taking place on the Mesa. Many of these facilities are not continuous because of the piecemeal nature of the development. This creates challenges for the subsequent developers that need to tie into the existing facilities. Many of the existing facilities are temporary. We were not able to obtain details on the drainage facilities in Mexico that receive most of the runoff.

Most of the development to-date has occurred in the East Watershed, which therefore includes most of the existing drainage facilities on the Mesa. The existing system is a combination of storm drains, improved channels, and detention basins, which in many areas discharge to natural drainage paths that do not have adequate hydraulic capacity.

The “Existing Drainage Facilities” drawing shows the facilities as-of the date of this report. The area is developing rapidly, and therefore new facilities are continuously being constructed. There are currently no dedicated drainage rights-of-way on the Mesa. Many of the projects, as they were mapped and constructed, dedicated portions of the properties to the city as drainage easements or flood water storage easements. Eventually, the systems and their easements will be continuous.

LEGEND

EXISTING STORM DRAIN	
DIRECTION OF FLOW	
EXISTING CHANNEL B=WIDTH Z=SLOPE (Z:1)	
EXISTING STREAM	
DETENTION BASIN	
MAJOR WATERSHED BOUNDARY	
OTAY MESA COMMUNITY PLAN BOUNDARY	
NEIGHBORHOOD BOUNDARY	

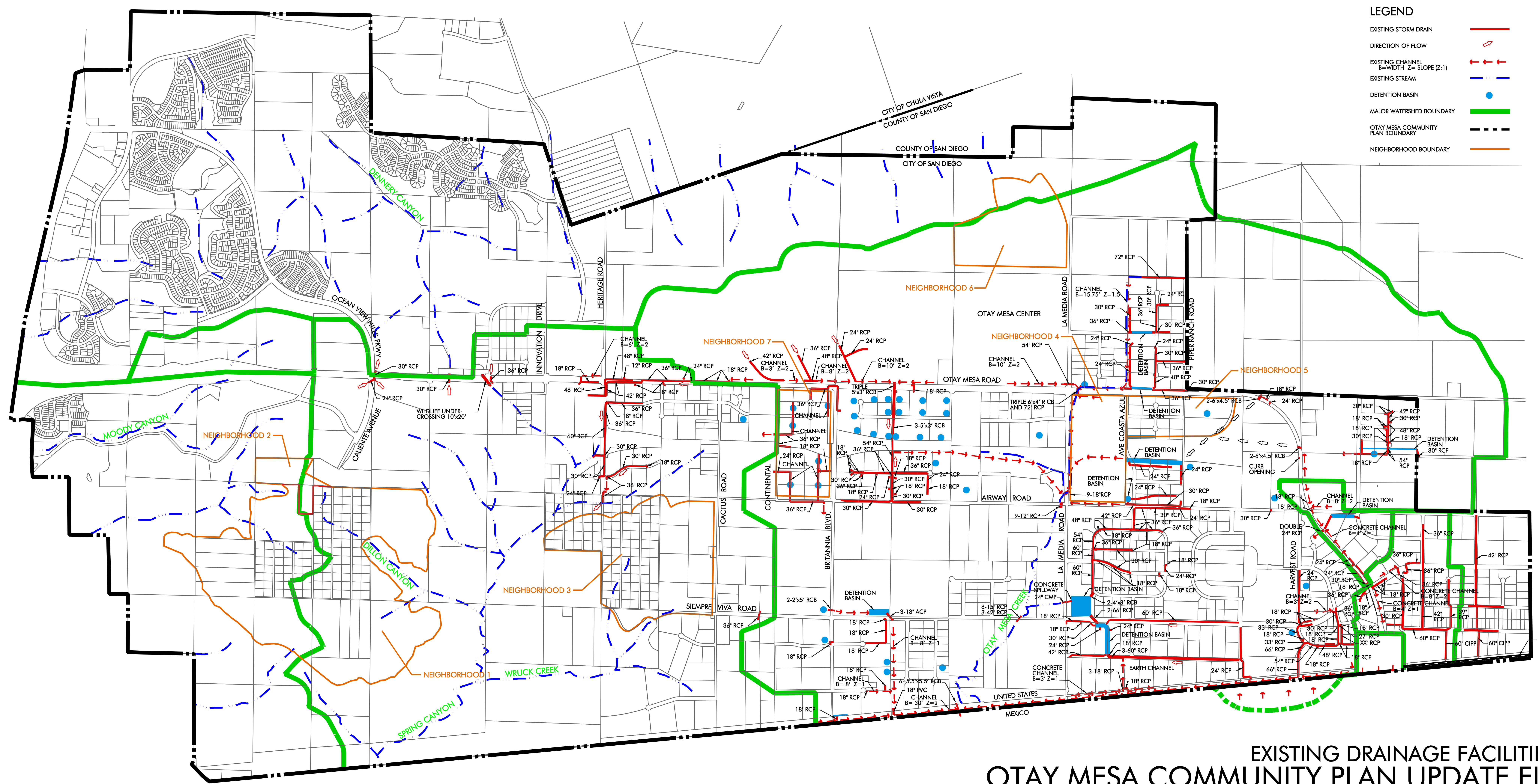

**EXISTING DRAINAGE FACILITIES
OTAY MESA COMMUNITY PLAN UPDATE EIR**

PROJECT NO. 03-027-0003 - 04/2005/06/07/08/09/10/11/12/13/14/15/16/17/18/19/20/21/22/23/24/25/26/27/28/29/30/31/32/33/34/35/36/37/38/39/40/41/42/43/44/45/46/47/48/49/50/51/52/53/54/55/56/57/58/59/60/61/62/63/64/65/66/67/68/69/70/71/72/73/74/75/76/77/78/79/80/81/82/83/84/85/86/87/88/89/90/91/92/93/94/95/96/97/98/99/100

III. HYDROLOGIC ANALYSIS

The Otay Mesa Study area is shown on the Watershed Map, and includes all of the Mesa area within the City of San Diego divided into five watersheds (with the exception of the far northwest arm of the Mesa, which is fully developed).

Watersheds	Acres	mi ²
West Perimeter Watershed	258	0.40
West Watershed	2,190	3.42
North Perimeter Watershed	590	0.92
East Watershed	3,864	6.04
Border Crossing Watershed	<u>223</u>	<u>0.35</u>
TOTAL	7,125	11.13

Most of the Mesa slopes from North to South, with the flow entering Mexico at several points. The northern and western perimeters of the Mesa flow into the adjacent Canyons. These perimeter watersheds are divided into several independent smaller watersheds. The watershed boundaries on the Mesa are not well defined because the Mesa is so flat. There are very few defined natural drainage paths, with much of the runoff sheet-flowing across the Mesa. The watershed boundaries shown are based on field investigations and best available mapping, but the actual drainage boundaries may be very different.

The only watershed that has been studied significantly from a drainage perspective is the East Watershed. Hydrologic models have been prepared for both of the previous drainage studies. The peak flows calculated in the two studies are different, primarily because of different assumptions relative to developed area, proposed drainage facilities, and watershed areas. The East Watershed includes a large area of unincorporated County property. The hydrologic model assumed the same industrial development for the unincorporated area. If land uses change in the County area, it may change the runoff rates. The differences for the concentration point at the border are shown below.

Q100 at Border East Watershed		
	Area (mi ²)	Q100(cfs)
1988 Study	5.72	5,050
1999 Study	6.63	3,529
2004 CPU	6.78	3,673

As part of this study, new hydrologic models have been prepared for the main watersheds which flow into the Tijuana River. For the East Watershed, HEC-1 has been used, since both previous studies used this model. For the other watersheds, the standard City of San Diego Modified Rational Method (AES) has been used. The results of these analyses are shown in the table below.

Hydrologic Analysis Summary			
	Area (mi ²)	Q50(cfs)	Q100(cfs)
West Perimeter Watershed	0.40	170	444
West Watershed	3.42	672	1,676
East Watershed	6.78	1,280	3,673
	10.60	2,122	5,793

In addition to the above flows, the Spring Canyon open space area contributes 109 cfs (Q50) and 257 cfs (Q100) from 1.2 mi². Since the Tijuana River Watershed is a water-quality impacted watershed, the quality and quantity of flow will need to be addressed before additional development takes place.

WATERSHED	CONCENTRATION POINT	AREA (ACRES)	Q ₅₀	Q ₁₀₀
WEST PERIMETER	OT3-1	19.4	18.3	51.4
	OT3-1A	14.8	12.0	32.1
	OT3-2	47.1	26.7	67.3
	OT3-3	11.8	10.6	29.3
	OT3-4	35.0	22.4	57.5
	OT3-5	16.5	13.3	35.8
	OT3-6	12.2	10.9	30.3
	OT3-7	46.1	27.7	70.4
	OT3-8	51.4	27.7	69.4
	254.3	169.5	443.5	
WEST	OT2-1	33.3	17.1	42.6
	OT2-2	126.2	41.4	99.5
	OT2-18	97.1	47.7	118.2
	OT2-19	27.7	22.3	60.1
	OT2-3	20.1	14.6	38.4
	OT2-4	67.8	38.5	96.9
	OT2-5	40.8	20.1	49.7
	OT2-6	34.8	17.1	42.4
	OT2-7	14.9	17.9	43.2
	OT2-8	81.3	43.0	108.7
	OT2-9	36.9	23.6	60.6
	OT2-9A	12.9	11.5	31.8
	OT2-10	128.4	43.1	103.8
	OT2-11	275.6	112.2	279.9
	OT2-12	23.6	17.5	46.0
	OT2-13	61.5	42.1	109.3
	OT2-14	48.4	26.1	65.3
	OT2-15	153.8	57.2	138.8
OT2-16	121.7	40.8	98.4	
OT2-17	60.3	17.8	42.5	
	1467.1	671.6	1676.1	
MEXICO	Canyon Area	774.8	109.3	257.0

May 23, 2005

IV. HYDRAULIC ANALYSIS

Most of the Mesa is very flat, resulting in local flooding during storms at the low points and along some drainage ditches. The only significant creek on the Mesa is the main channel in the East Watershed, Otay Mesa Creek, which flows from North to South along La Media Road and crosses the border into Mexico just north of the Tijuana Airport.

A HEC-RAS hydraulic model was prepared for this channel from the border north to Otay Mesa Road. The purpose of this model was to identify the 100-year floodplain for this reach for present conditions. The proposed future drainage project along this alignment will be designed to contain the 100-year flow, reducing or eliminating flooding impacts to adjacent properties.

The HEC-RAS model was also used to size the proposed new channel from Airway Road to just south of Siempre Viva Road. Several alternative cross-sections were modeled to reflect input on the environmental aspects of the channel.

A significant tributary to the main channel enters just upstream of the Siempre Viva Road crossing. This tributary conveys flow from the De La Fuente Business Park and the Siempre Viva Business Park. The existing channel from La Media Road to the proposed main channel is approximately 15 feet wide and 4 feet deep, with a hydraulic capacity of approximately 120 cfs. The 100 year flow in this channel is 1116 cfs. A proposed new channel has a 50 ft bottom width with 1.5:1.0 side slopes and will convey the 100 year flow. A double 10' x 4.5' RCB will also be required for the flow under La Media Road. The cost estimate does not include these facilities.

1-4-05

OTAY MESA CPU

HEC-RAS Plan: Plan 01 River: Otay Mesa Drains Reach: Channel Profile: PF 1

Reach	River Sta	Profile	Q Total (cfs)	Min Ch El (ft)	W.S. Elev (ft)	Crit W.S. (ft)	E.G. Elev (ft)	E.G. Slope (ft/ft)	Vel Chnl (ft/s)	Flow Area (sq ft)	Top Width (ft)	Froude #	Chl
Channel	5500	PF 1	2500.00	464.60	471.08		471.16	0.002743	2.33	1073.59	200.00	0.18	
Channel	5350	PF 1	2500.00	464.23	470.69		470.76	0.002572	2.16	1279.19	335.44	0.17	
Channel	5100	PF 1	2500.00	463.60	470.06		470.12	0.002591	2.17	1275.99	335.16	0.17	
Channel	4800	PF 1	2500.00	462.85	469.27		469.33	0.002666	2.19	1263.56	334.04	0.18	
Channel	4500	PF 1	2500.00	462.10	468.51		468.56	0.002430	2.08	1358.84	378.24	0.17	
Channel	4200	PF 1	2500.00	461.35	467.79		467.85	0.002365	2.07	1371.79	379.61	0.17	
Channel	3900	PF 1	2500.00	460.60	467.09		467.15	0.002266	2.04	1392.50	381.79	0.16	
Channel	3600	PF 1	2500.00	459.85	466.30		466.37	0.002969	2.32	1153.04	281.59	0.19	
Channel	3300	PF 1	2500.00	459.10	465.33		465.42	0.003423	2.41	1109.99	285.62	0.20	
Channel	3050	PF 1	3000.00	458.48	463.50		463.74	0.014532	4.06	777.90	261.33	0.39	
Channel	2900	PF 1	3000.00	458.10	463.23	461.14	463.61	0.000245	4.97	603.31	222.92	0.41	
Channel	2850	PF 1	3000.00	457.60	462.74	461.24	463.55	0.000521	7.22	415.32	168.05	0.58	
Channel	2750	Culvert											
Channel	2640	PF 1	3000.00	455.59	462.07	458.95	462.52	0.011957	5.38	557.46	183.64	0.37	
Channel	2500	PF 1	3000.00	455.38	461.81		461.87	0.001846	2.07	1492.22	277.64	0.15	
Channel	2300	PF 1	3000.00	455.08	461.31		461.40	0.003272	2.45	1261.91	277.98	0.19	
Channel	2100	PF 1	3000.00	454.78	460.34		460.48	0.006864	3.05	1006.36	275.43	0.27	
Channel	2050	PF 1	3000.00	454.70	460.11		460.21	0.003838	2.56	1191.75	275.37	0.21	
Channel	2000	PF 1	3000.00	454.63	460.00	456.55	460.06	0.002196	2.06	1582.39	378.00	0.16	

Channel1-3-05 Plan: Plan 01 1/3/2005

Olay Mesa Draina Channel

Legend	
EG PF 1	(Symbol)
WS PF 1	(Symbol)
Crit PF 1	(Symbol)
Ground	(Symbol)

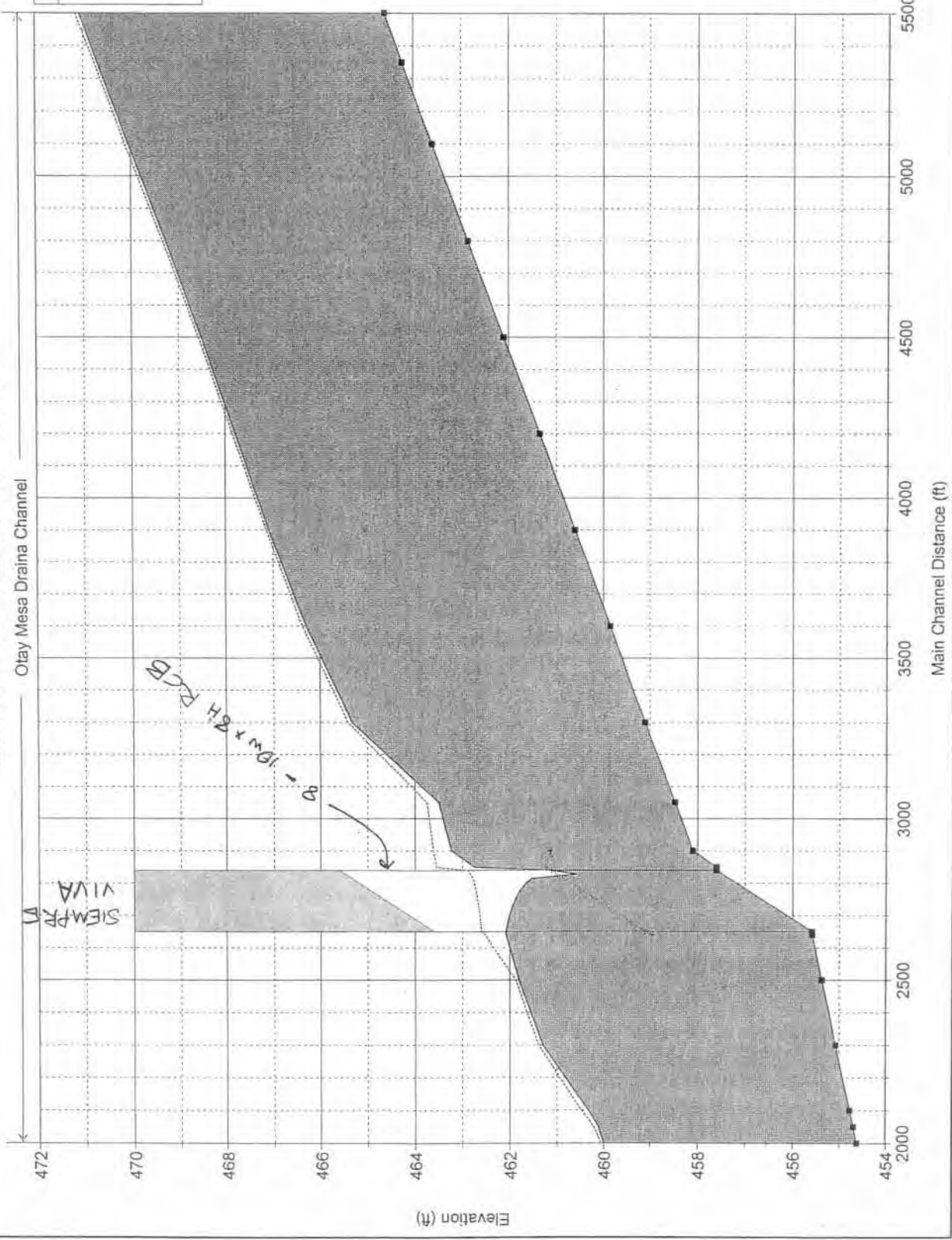

Channel1-3-05 Plan: Plan 01 1/4/2005
RS = 5500

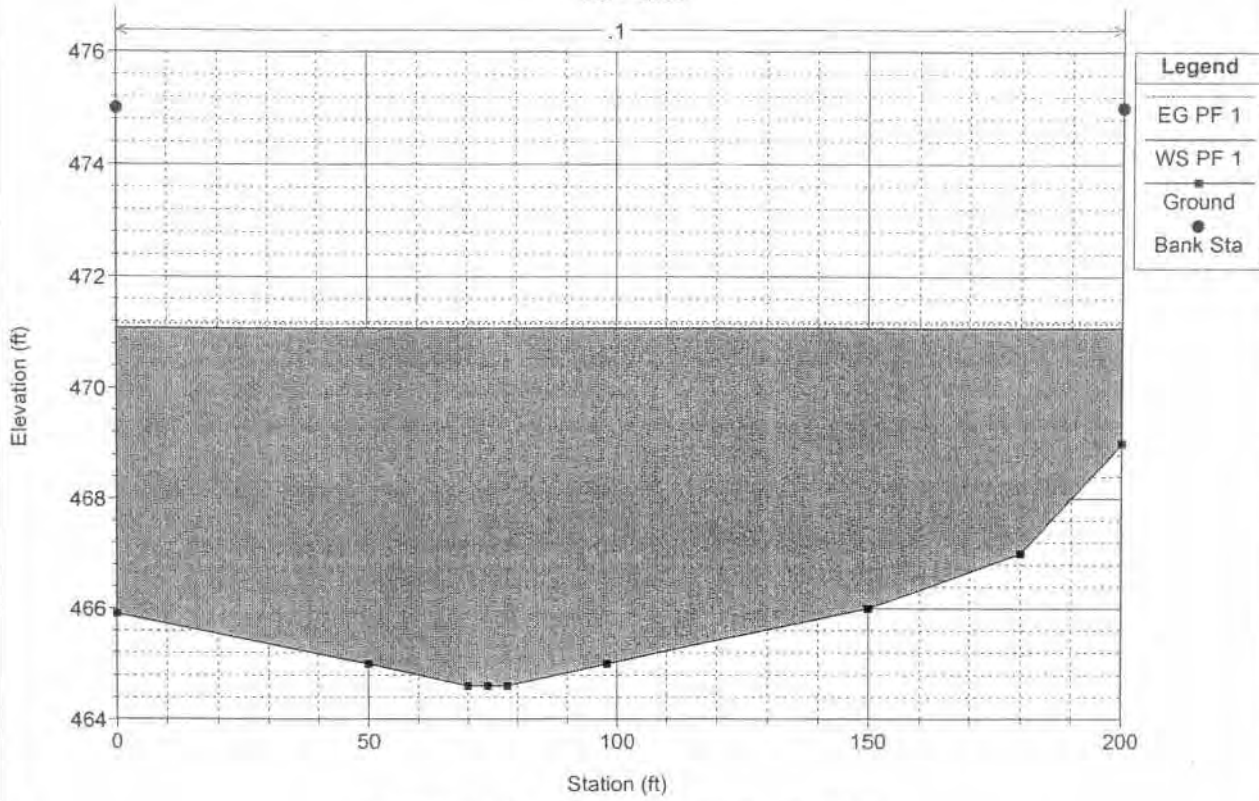

Channel1-3-05 Plan: Plan 01 1/4/2005
RS = 5350

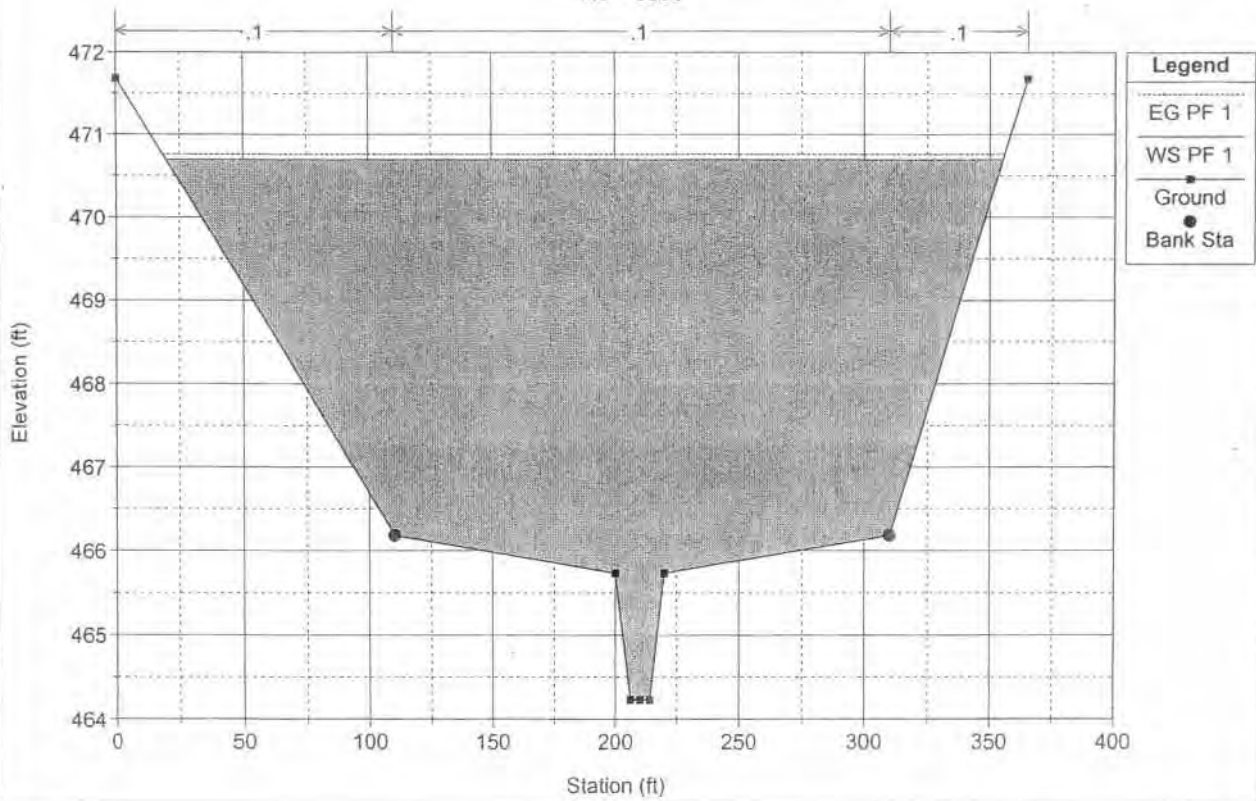

Channel1-3-05 Plan: Plan 01 1/4/2005
RS = 5100

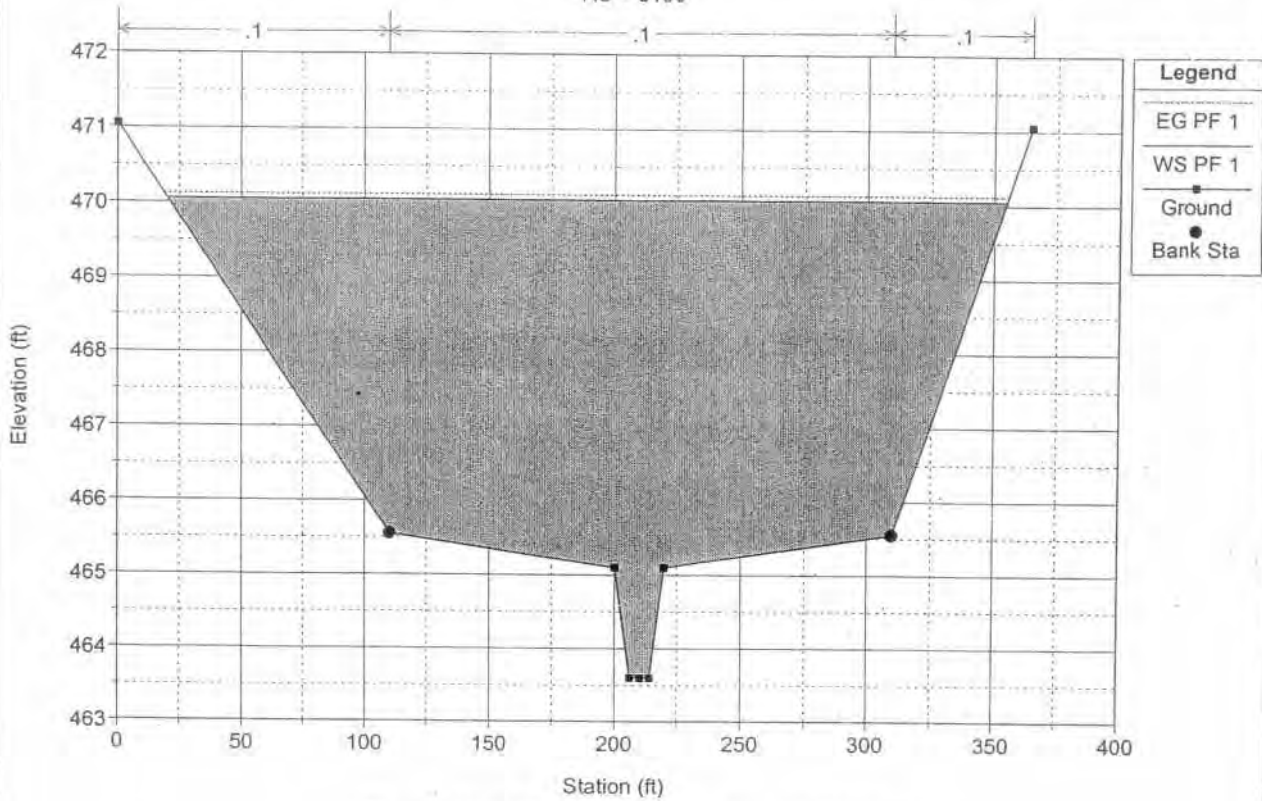

Channel1-3-05 Plan: Plan 01 1/4/2005
RS = 4800

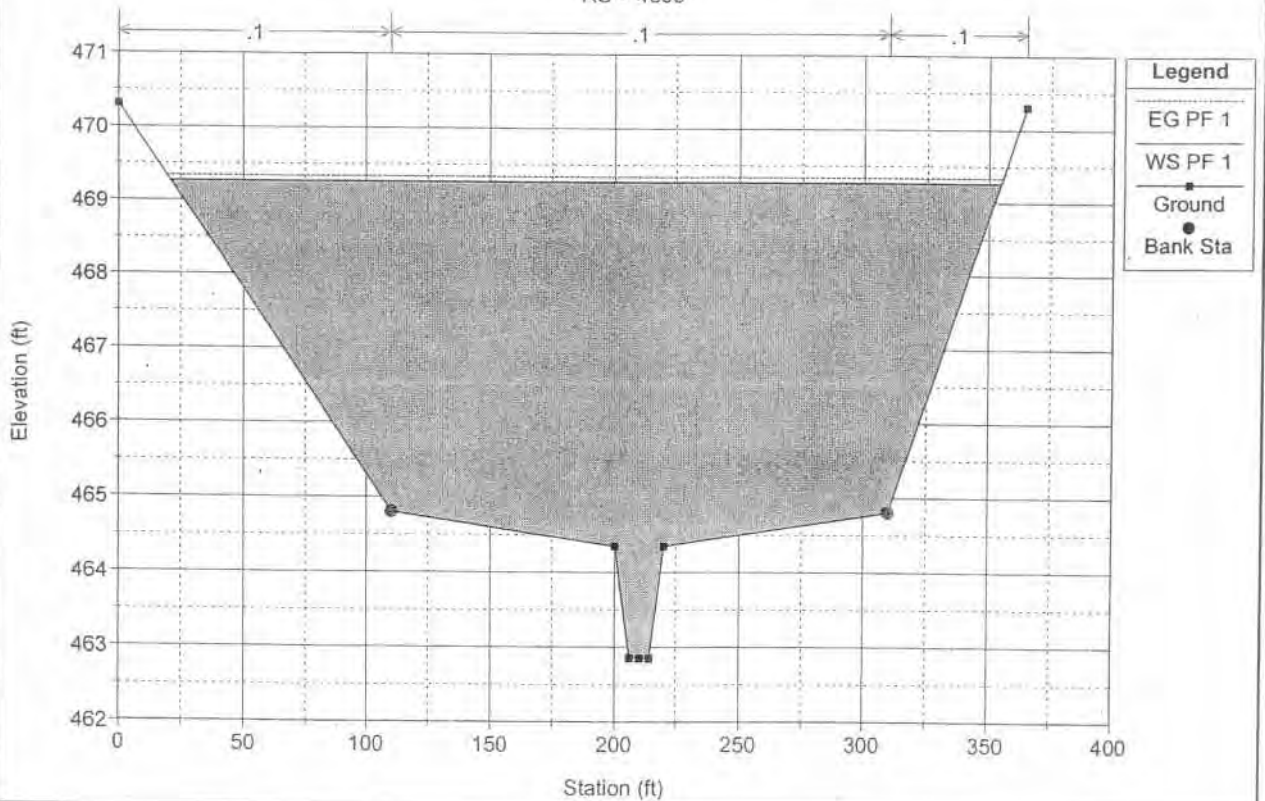

Channel1-3-05 Plan: Plan 01 1/4/2005
RS = 4500

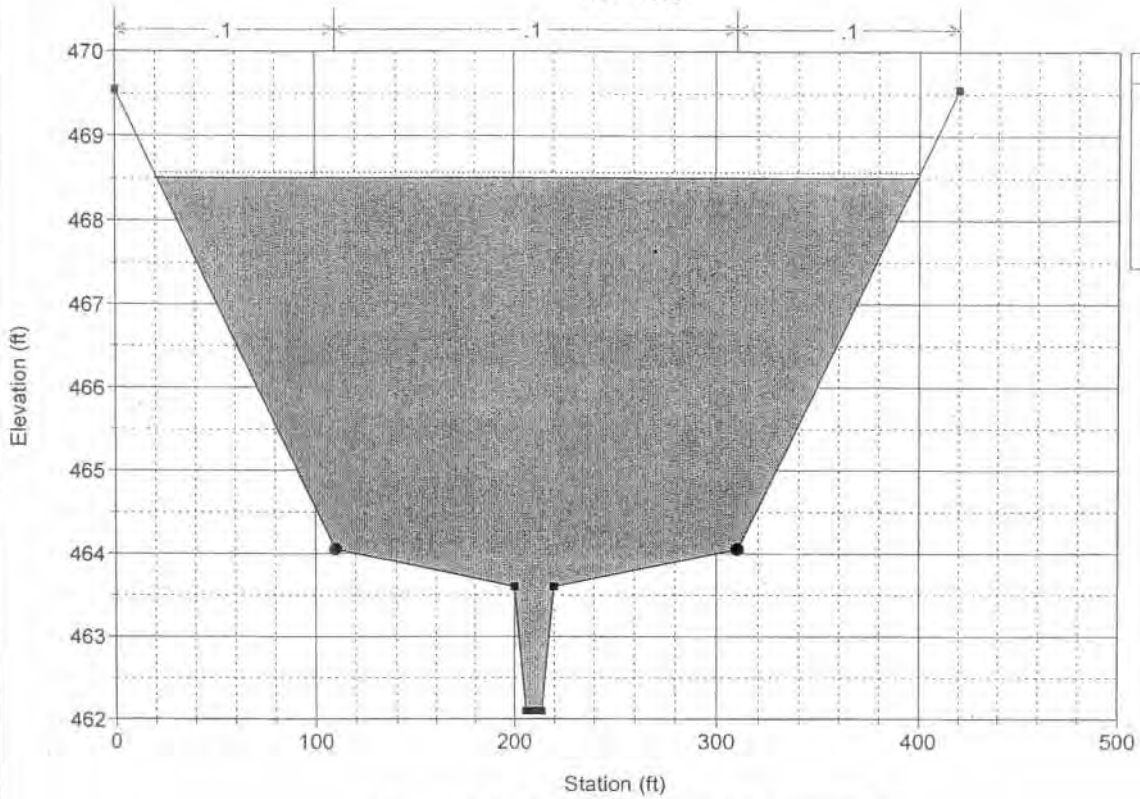

Legend	
EG PF 1	—
WS PF 1	—
Ground	●
Bank Sta	●

Channel1-3-05 Plan: Plan 01 1/4/2005
RS = 4200

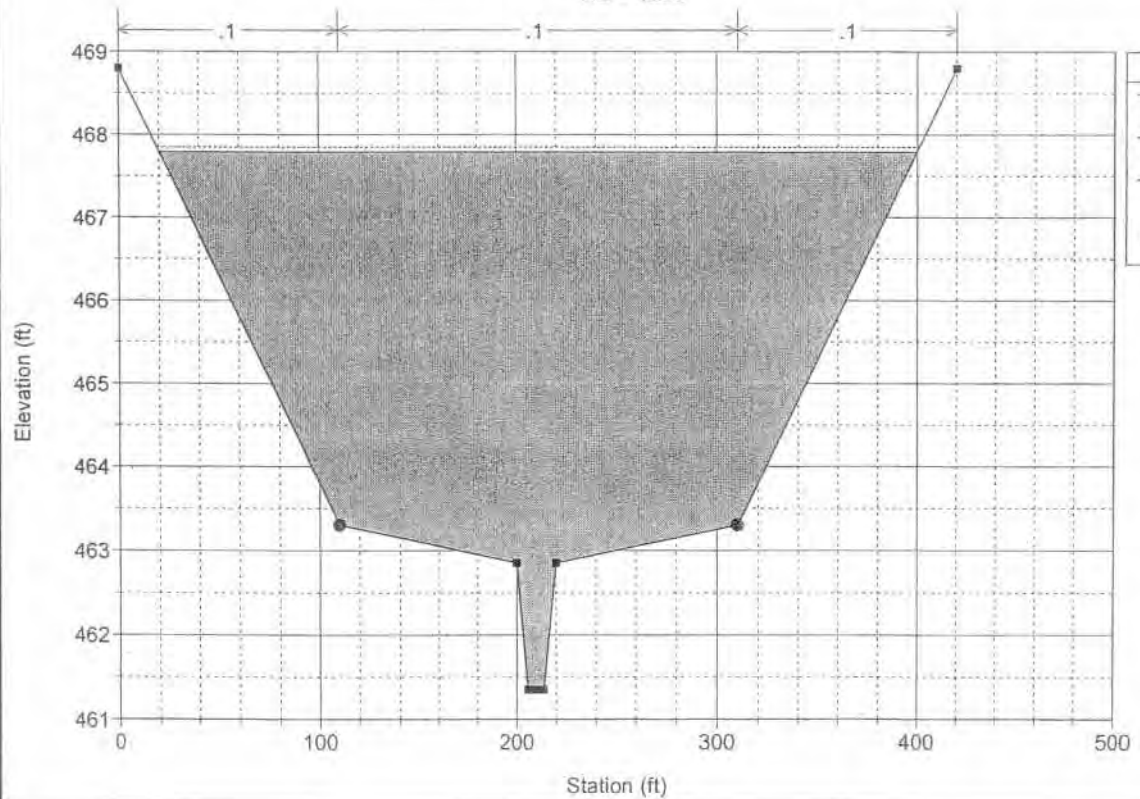

Legend	
EG PF 1	—
WS PF 1	—
Ground	●
Bank Sta	●

Channel1-3-05 Plan: Plan 01 1/4/2005
RS = 3900

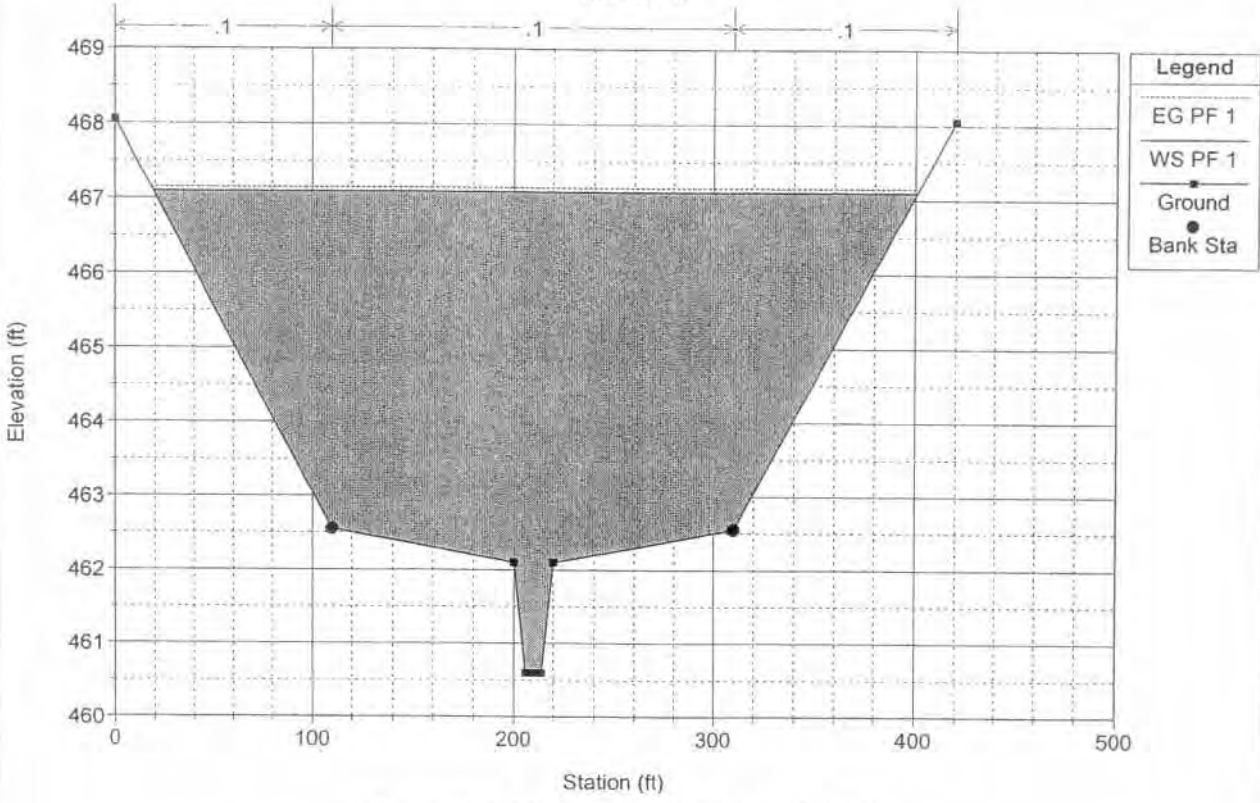

Channel1-3-05 Plan: Plan 01 1/4/2005
RS = 3600

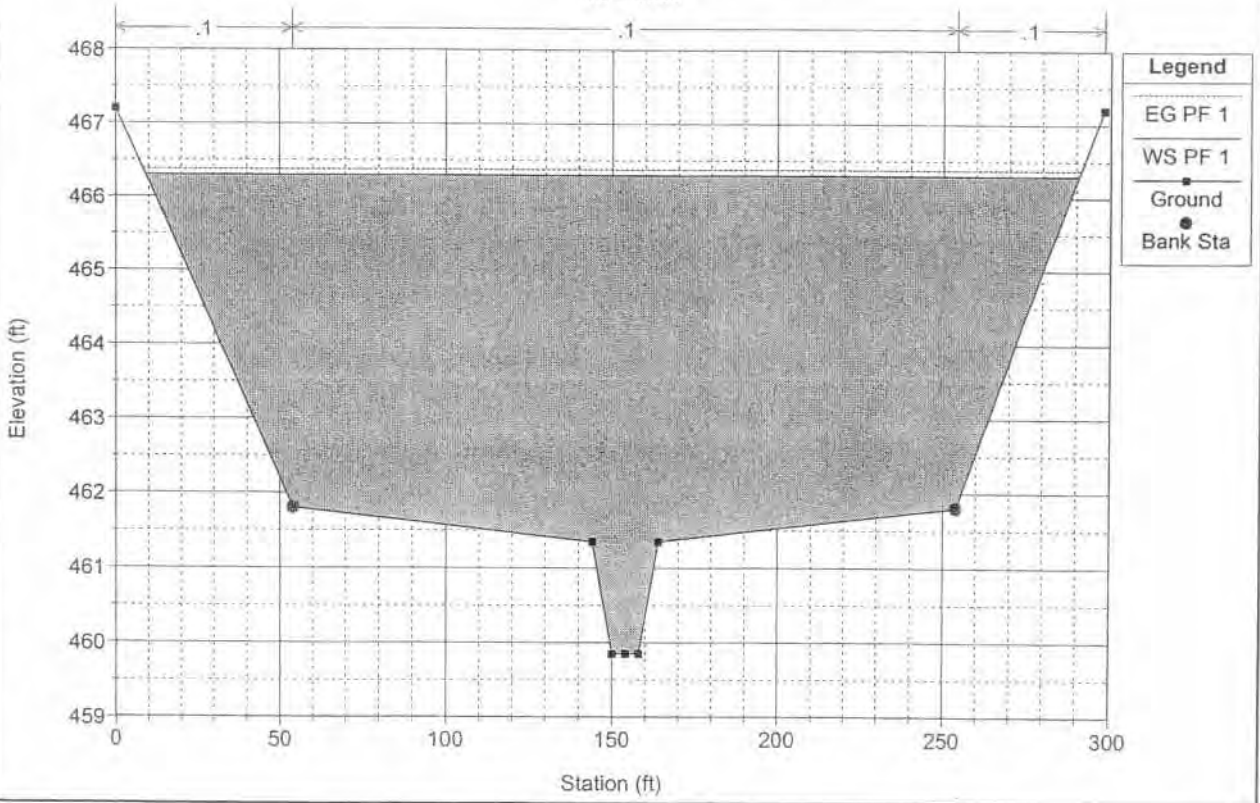

Channel1-3-05 Plan: Plan 01 1/4/2005

RS = 3300

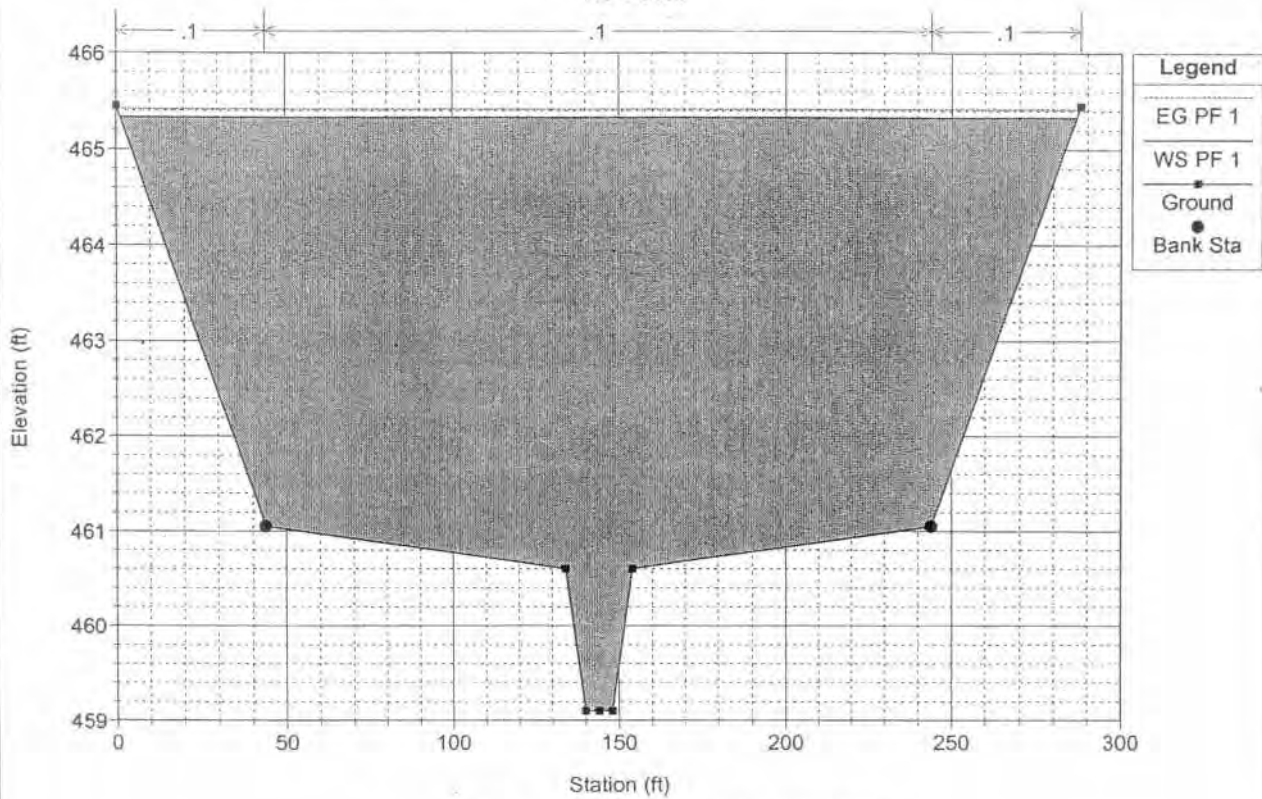

Channel1-3-05 Plan: Plan 01 1/4/2005

RS = 3050

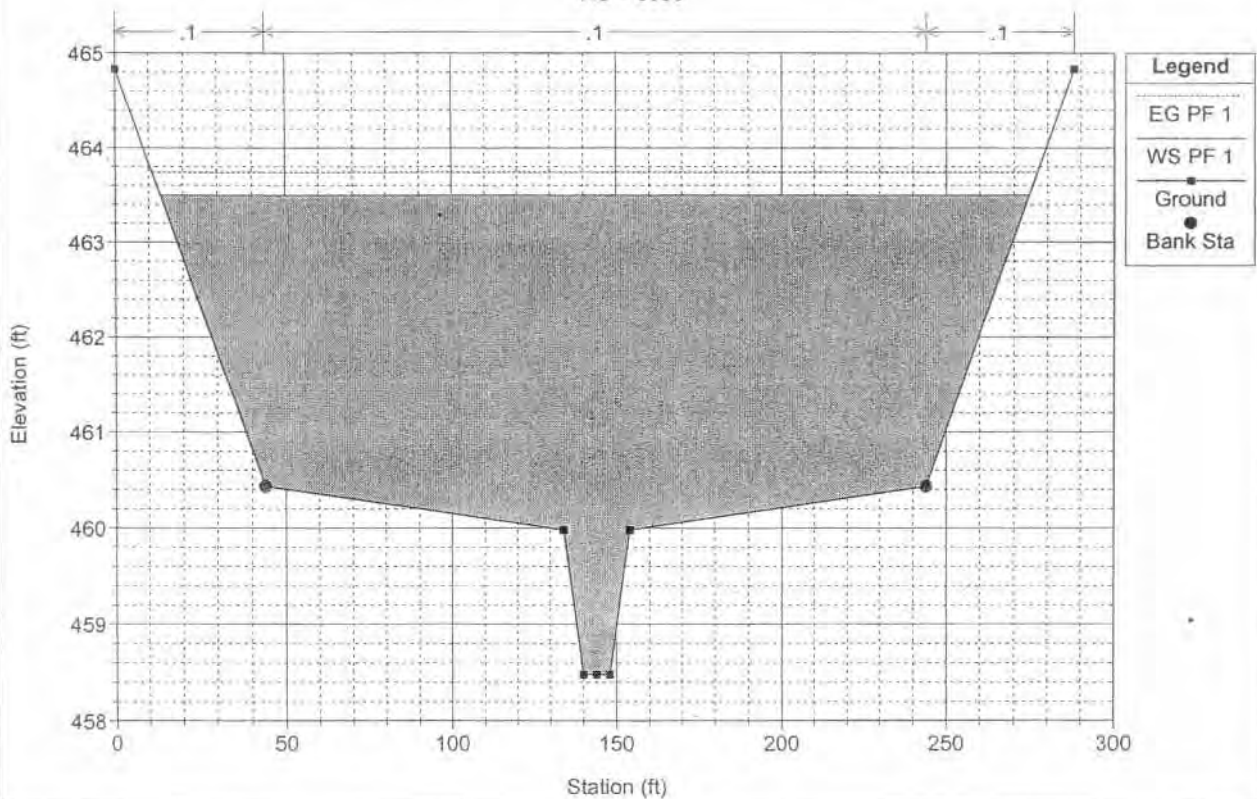

Channel1-3-05 Plan: Plan 01 1/4/2005
RS = 2900

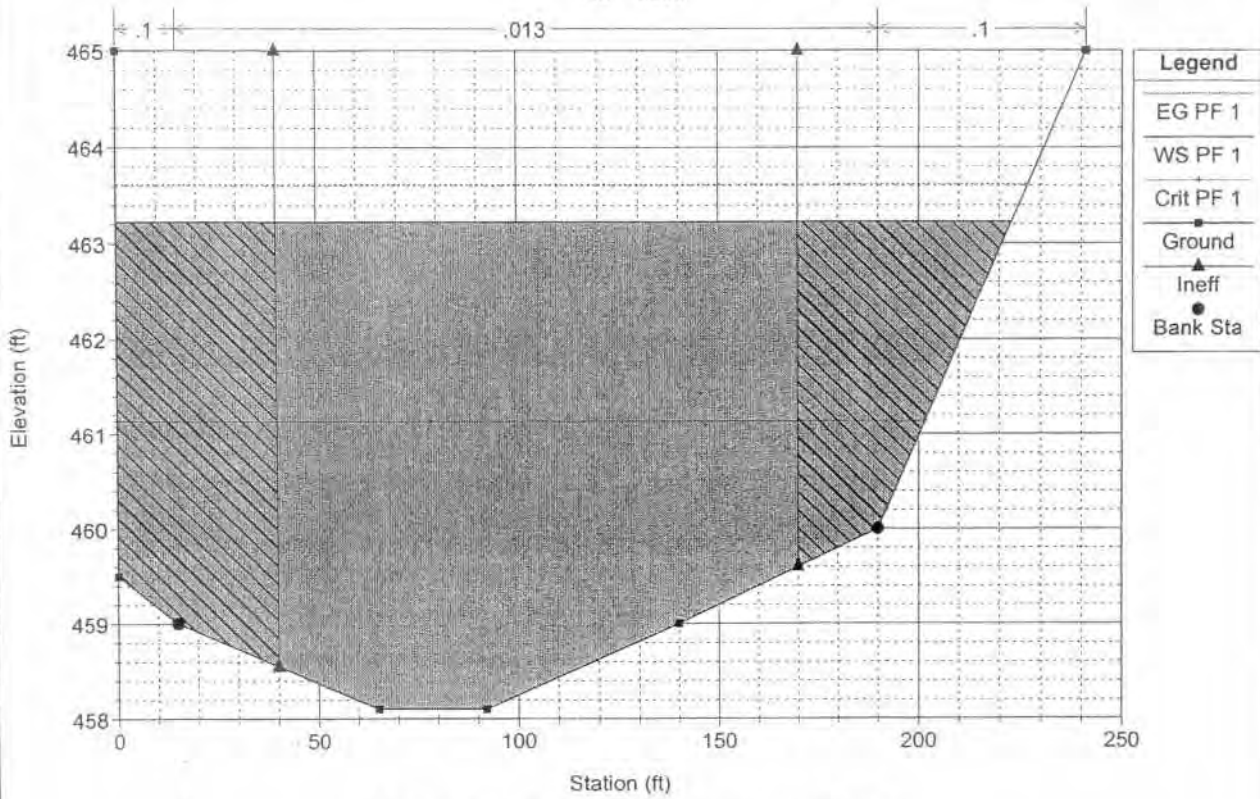

Channel1-3-05 Plan: Plan 01 1/4/2005
RS = 2850

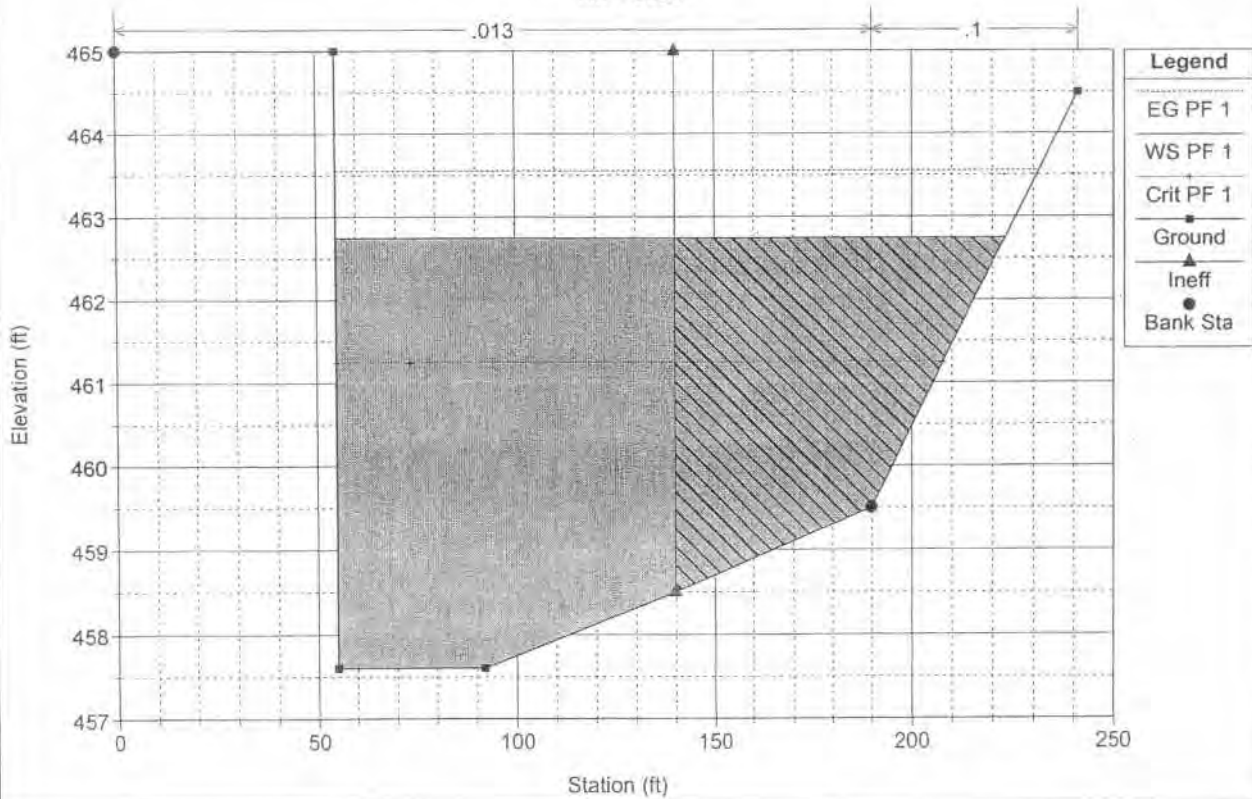

Channel1-3-05 Plan: Plan 01 1/4/2005

RS = 2750 Culv

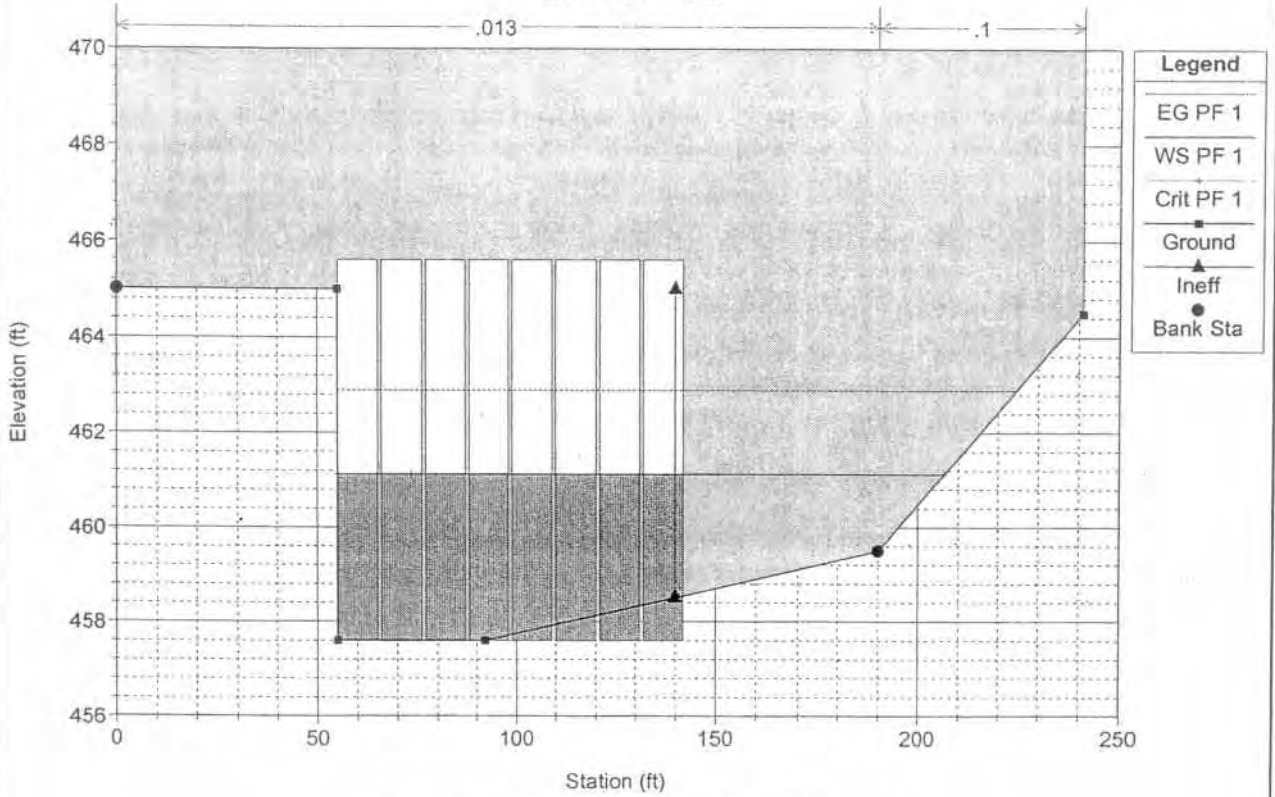

Channel1-3-05 Plan: Plan 01 1/4/2005

RS = 2750 Culv

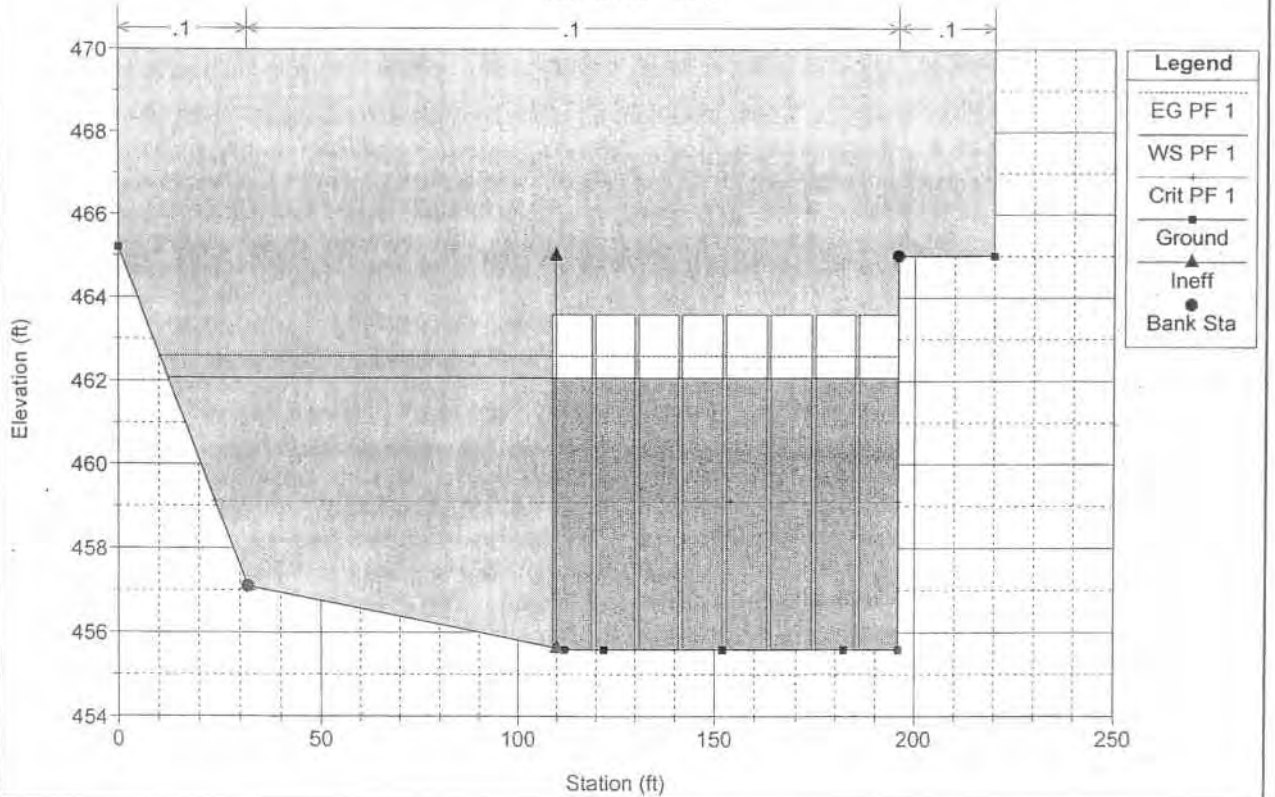

Channel1-3-05 Plan: Plan 01 1/4/2005
RS = 2640

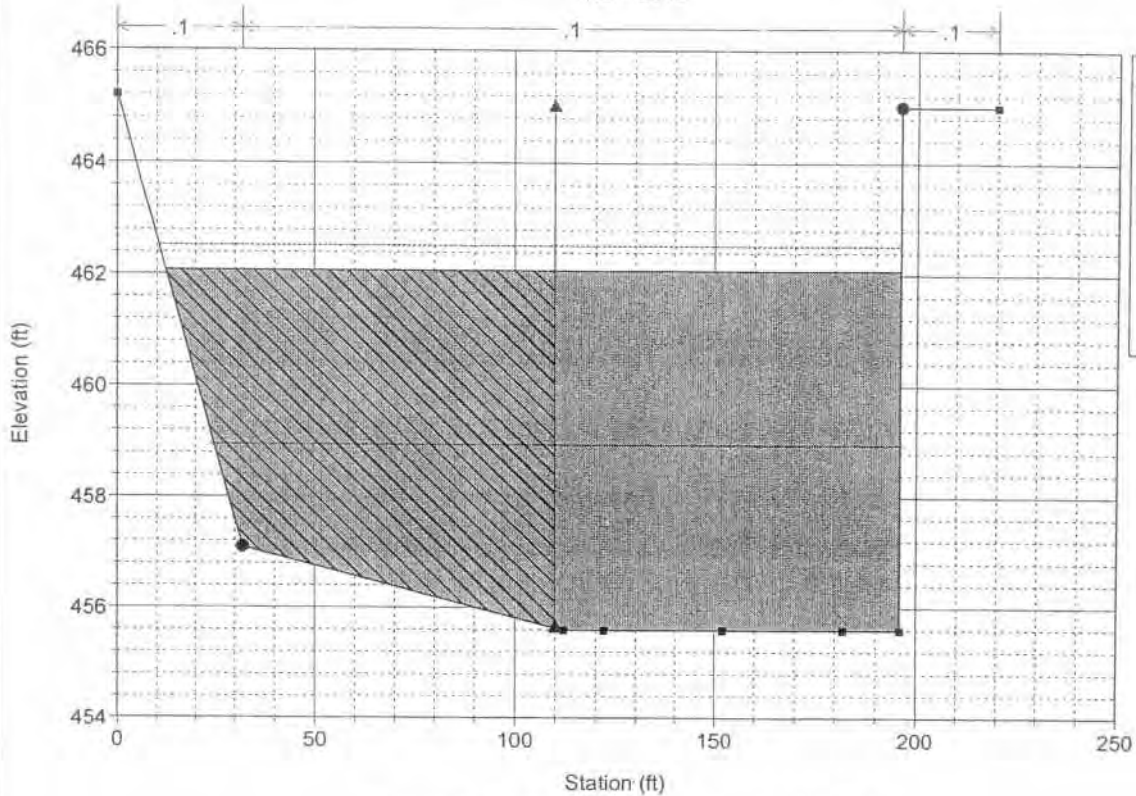

Channel1-3-05 Plan: Plan 01 1/4/2005
RS = 2500

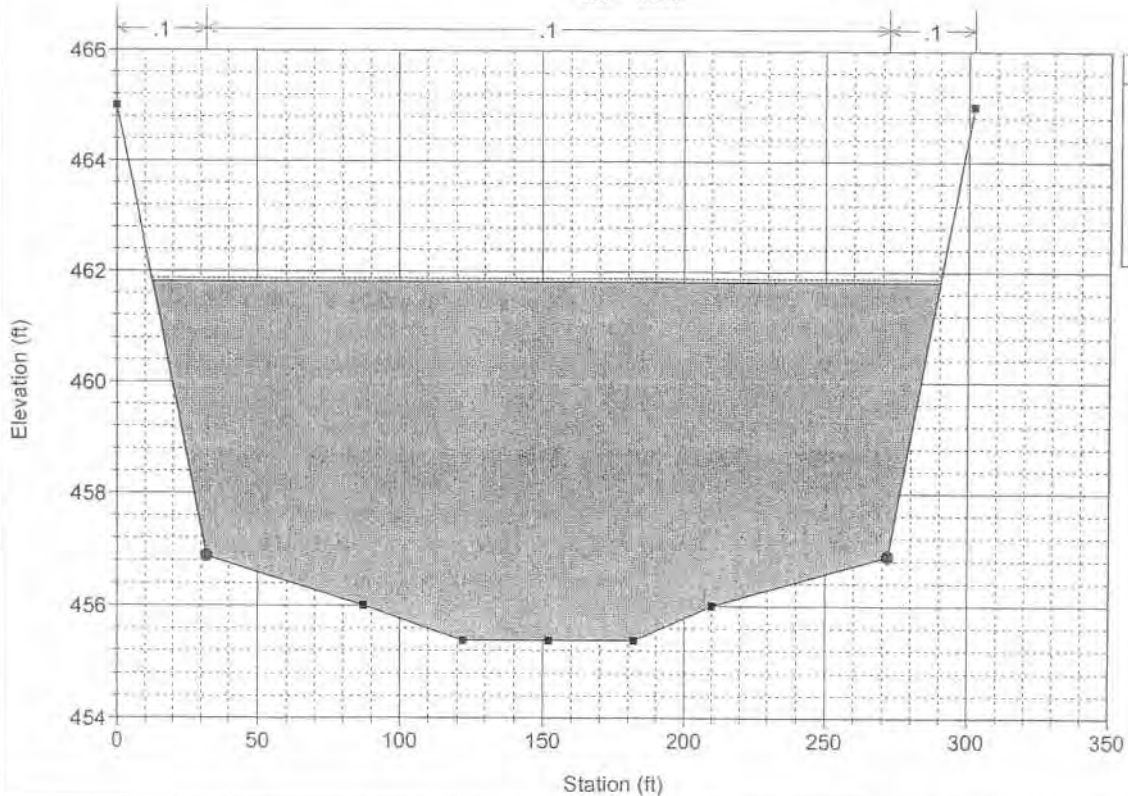

Channel1-3-05 Plan: Plan 01 1/4/2005
RS = 2300

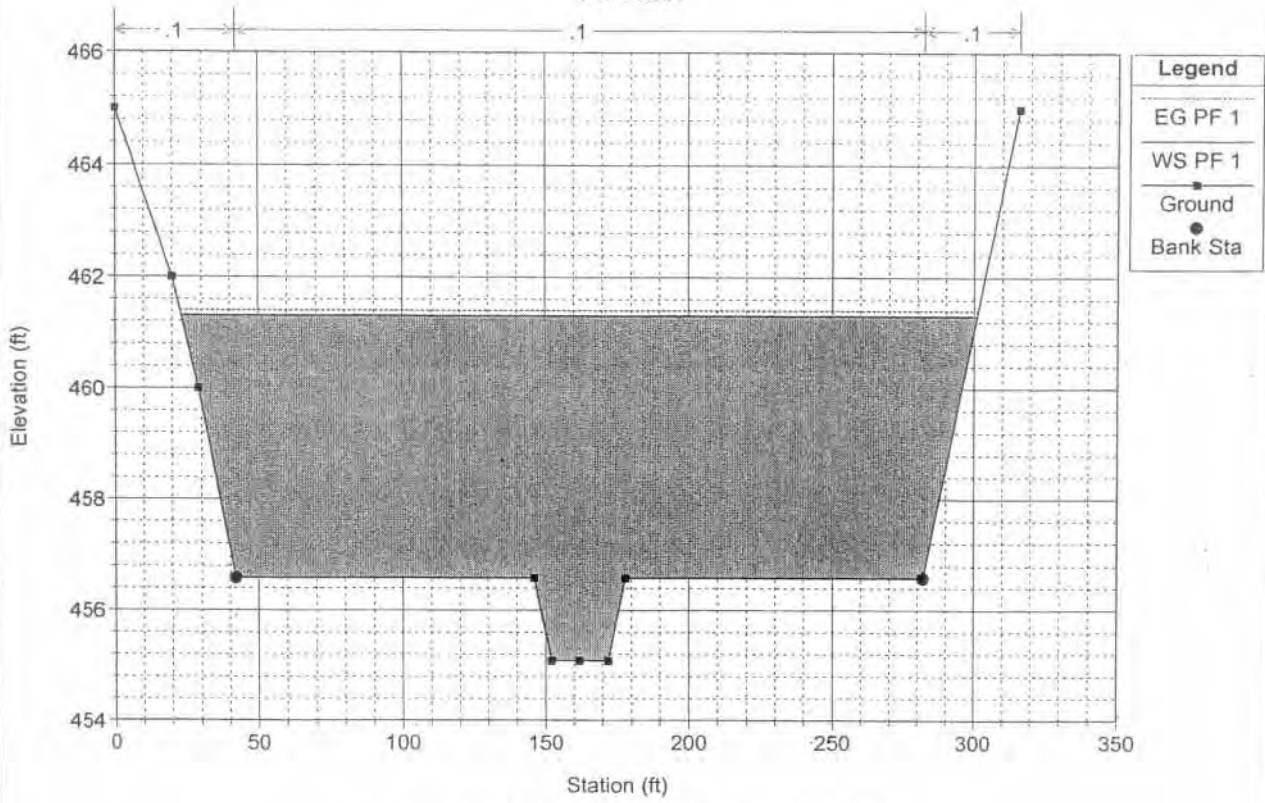

Channel1-3-05 Plan: Plan 01 1/4/2005
RS = 2100

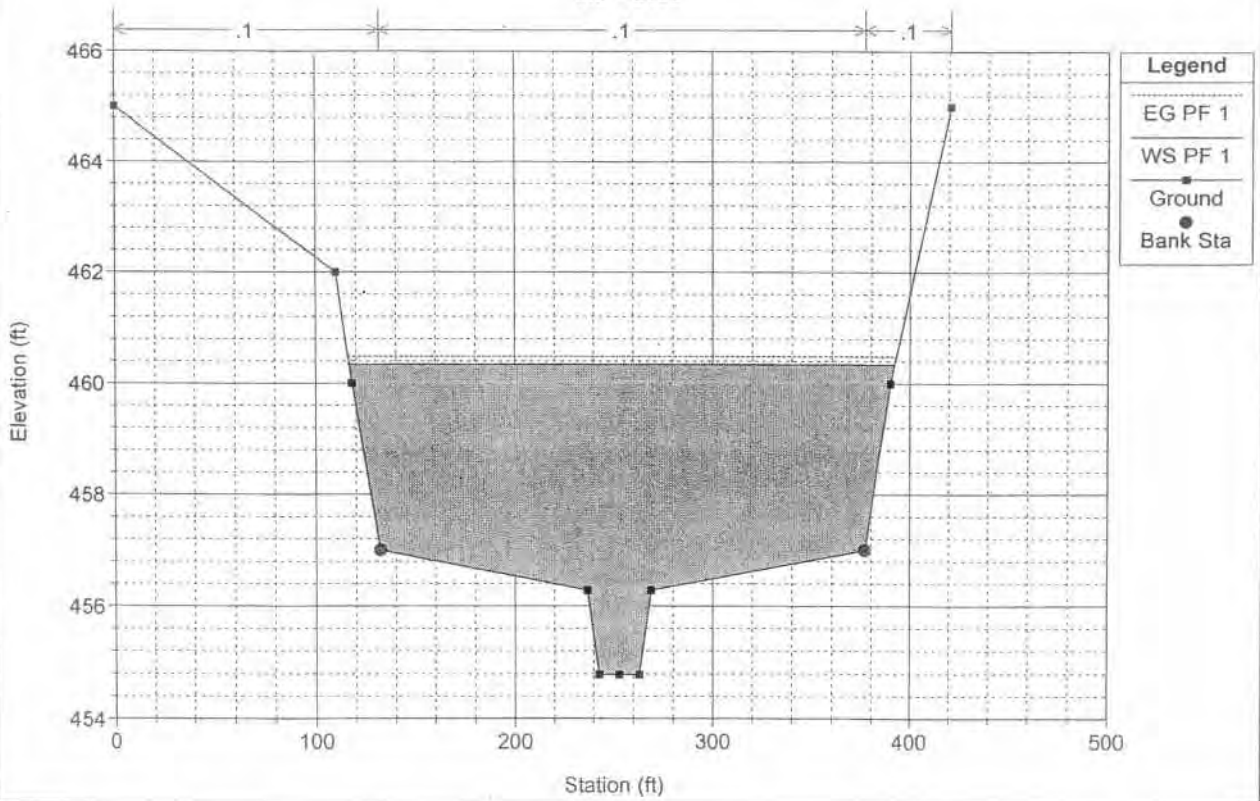

Channel1-3-05 Plan: Plan 01 1/4/2005
RS = 2050

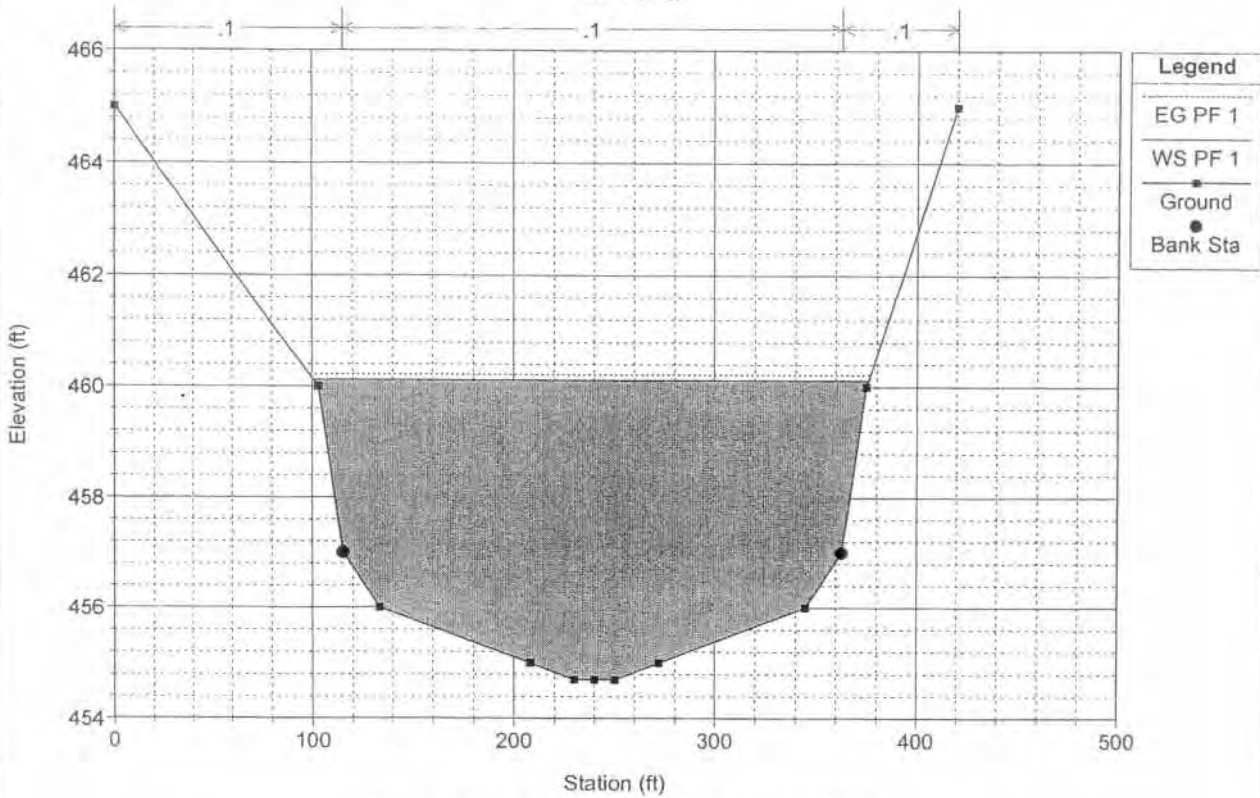

Channel1-3-05 Plan: Plan 01 1/4/2005
RS = 2000 Channel at entrance to detention basin

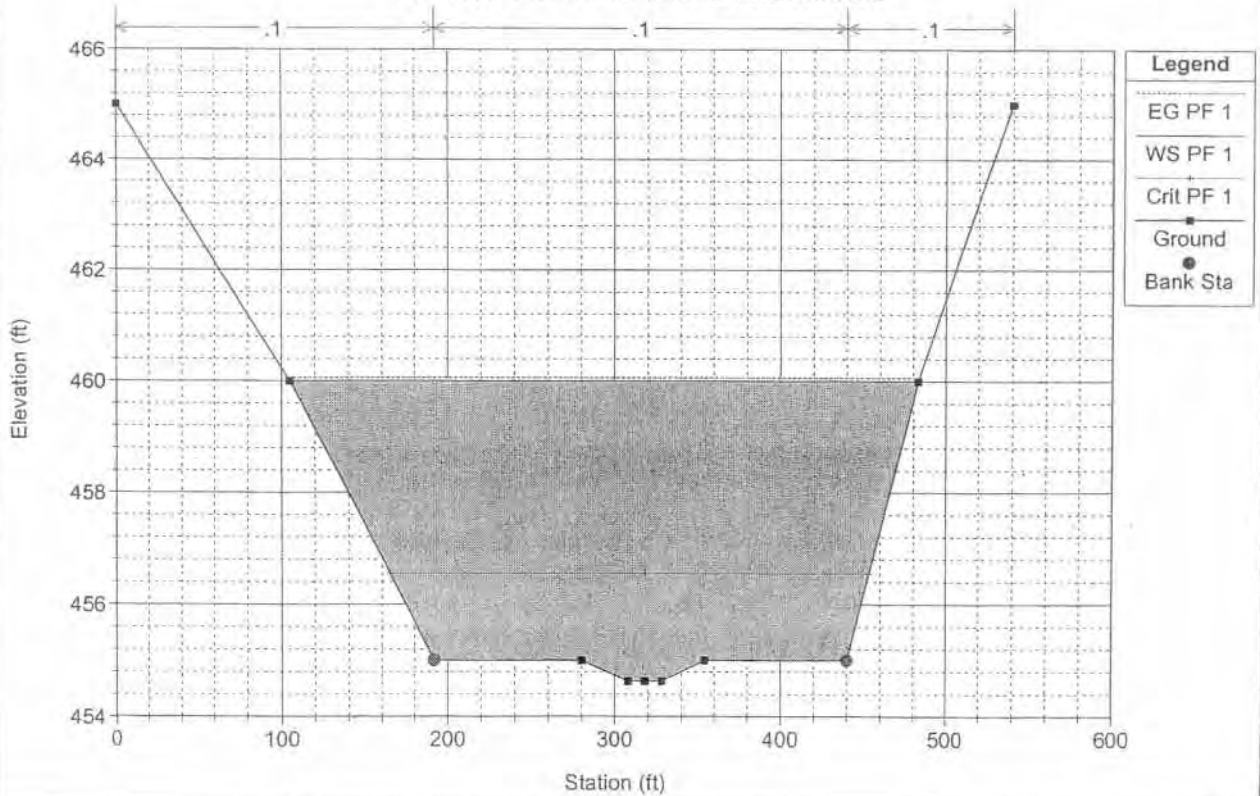

Worksheet

Worksheet for Trapezoidal Channel

Project Description	
Worksheet	Trapezoidal Channel - 1
Flow Element	Trapezoidal Channel
Method	Manning's Formula
Solve For	Discharge

Input Data	
Mannings Coefficient	0.045
Slope	0.006150 ft/ft
Depth	4.00 ft
Left Side Slope	1.50 H : V
Right Side Slope	1.50 H : V
Bottom Width	50.00 ft

Results	
Discharge	1,331.30 cfs
Flow Area	224.0 ft ²
Wetted Perimeter	64.42 ft
Top Width	62.00 ft
Critical Depth	2.73 ft
Critical Slope	0.022466 ft/ft
Velocity	5.94 ft/s
Velocity Head	0.55 ft
Specific Energy	4.55 ft
Froude Number	0.55
Flow Type	Subcritical

Cross Section

Cross Section for Trapezoidal Channel

Project Description	
Worksheet	Trapezoidal Channel - 1
Flow Element	Trapezoidal Channel
Method	Manning's Formula
Solve For	Discharge

Section Data	
Mannings Coefficient	0.045
Slope	0.006150 ft/ft
Depth	4.00 ft
Left Side Slope	1.50 H : V
Right Side Slope	1.50 H : V
Bottom Width	50.00 ft
Discharge	1,331.30 cfs

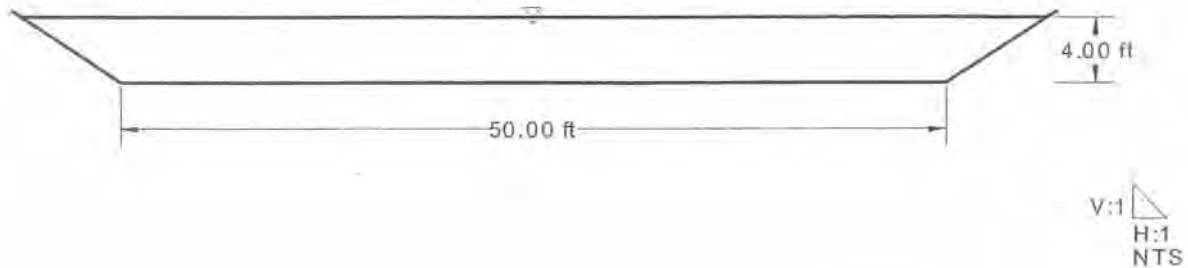

V. PROPOSED DRAINAGE FACILITIES

For most of the Mesa, drainage facilities are constructed as part of development or road projects, and include only facilities in the immediate vicinity of the projects. For the proposed future private development, no designs are available to show these future facilities. Caltrans has prepared plans for their SR-905 project, and those facilities are shown on the attached map.

The only Master Planned facility which needs to be constructed before development takes place is the Main Channel and Detention basin in the East Watershed. Details of this system are presented in Section VI.

LEGEND

PROPOSED FUTURE STORM DRAIN	
PROPOSED CHANNEL	
PROPOSED DETENTION BASIN	
EXISTING STREAM	
WATERSHED BOUNDARY	
OTAY MESA COMMUNITY PLAN BOUNDARY	

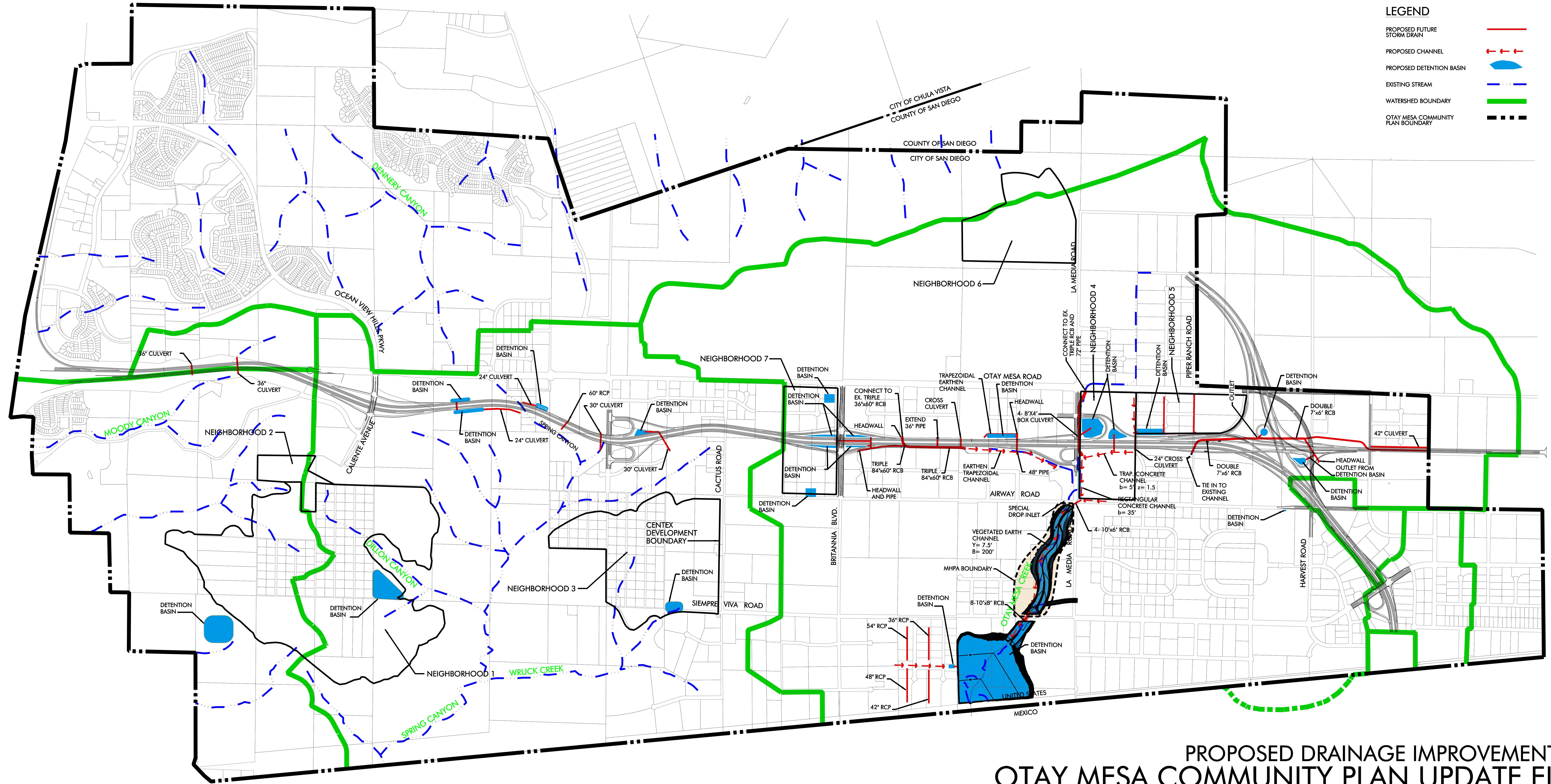

**PROPOSED DRAINAGE IMPROVEMENTS
OTAY MESA COMMUNITY PLAN UPDATE EIR**

PROJECT NO. 03-027-0018 - 04/20/05 11:54:40 AM

VI. PROPOSED DRAINAGE ALTERNATIVES

The historical drainage on the Mesa, with its flat terrain and shallow swales for drainage paths, did not become a problem until development started taking place in the 1960s. This development started concentrating flows in culverts under roads and redefined some of the historical drainage paths. Some of the development solved problems in some areas, but impacted other areas by moving the problem downstream. One of these areas is the existing creek that parallels La Media Road and eventually crosses the border into Mexico. The frequent flooding along portions of this channel is a constraint to future development for some of the areas along the creek.

1. NO PROJECT

The alternative of doing nothing to improve the drainage along the main creek channel would prevent future development from taking place along portions of La Media Road. The existing creek is not deep enough to allow the adjacent properties to drain effectively. To provide continued access along the truck route during storms, if the channel is not constructed, the roads will need to be raised or alternative routes identified. The existing intersection of Airway Road and La Media Road floods after any significant precipitation. The adjacent roads are too low to allow significant flows to pass under them, so they flood frequently. If the roads are raised to allow more flow to pass under them, they will impact the already-developed adjacent property, parts of which would now be lower than the roads, creating even more difficult drainage issues for the properties.

2. CONCRETE CHANNEL

The 1999 Otay Mesa Drainage Study recommended a concrete channel from Otay Mesa Road to the Border Detention Basin. The recommended plan was a concrete channel along the east side of La Media Road until reaching Siempre Viva Road, where it crossed under La Media and followed on the north side of Siempre Viva to box culverts under Siempre Viva that connected to the Border Detention Basin. All of the concrete channel alternatives assumed that the existing creek with its habitat would continue to carry low flows. The 1999 cost for this alternative was \$10.6 million, which would be approximately \$14.9 million in 2005 dollars without land acquisition.

3. LA MEDIA CHANNEL AND BORDER DETENTION BASIN

The largest watershed on the Mesa is the East Watershed, which covers an area of 6.78 square miles (4,340 Acres). All of the flow from this watershed collects at a concentration point at a large culvert where it crosses the border with Mexico and flows under the airport access road and airport runway before flowing into the Tijuana River.

This portion at the Mesa is extremely flat, and the adjacent properties can not effectively drain into the existing small creek channel without raising the elevations of the roads and developments near the creek. To allow for future development and to accommodate runoff from proposed future projects, a new channel is required with inverts from 3 to 5 feet below the existing creek channel.

The proposed channel has a bottom width that varies from 240 feet at the new border detention basin to 200 feet from north of Siempre Viva Road to the Airway Road/La Media Road intersection. The side slopes will vary between 4:1 to 10:1. Heavy riparian vegetation will be allowed to grow in the channel and no annual maintenance will be required. Once the vegetation has matured, maintenance of dead or fallen trees may be required every few years. There will be a 12 foot wide access road on each bank. The Channel will contain the 100 year flood flow with mature vegetation growth.

From the Airway Road/La Media Road intersection, a 35 foot wide concrete channel along the east side of La Media Road will connect with the proposed Caltrans culverts which will be constructed with SR 905. The RCB culverts under the intersection will need to accommodate existing utilities in both roads, which may impact the intersection and the utilities.

The Border Detention Basin will be designed to attenuate the peak post-development flows down to their pre-development levels for flows from 5 year through 100 year storms. The outlet structure will be less than six feet high, and will not be under the jurisdiction of the State of California DSOD. The design of the outlet structure will be prepared with final plans for the project. The Detention Basin will be approximately 1700' by 1500' and cover an area of approximately 58 acres.

Border Detention Basin

Area:	58 Acres
Max. Water Depth:	6.0 Feet
Max. Storage Volume:	308 AF

The basin will be graded to appear natural. Natural vegetation will be allowed to grow in the basin and no annual maintenance will be required. A low-flow stream will be created through the basin. A Maintenance Assessment District may be created for maintaining the channel and detention basin.

The basin and channel will require the removal of approximately 915,000 CY of soil. It is assumed that this export will be used on adjacent properties to raise the building pad grades thereby limiting the haul distance. A preliminary cost estimate was prepared which reflects both the construction costs and the land acquisition costs. A Property Ownership Map which shows the ownership within the East Watershed is attached.

La Media Channel and Border Detention Basin

Preliminary Opinion of Probable Construction Cost

2/8/2005

Kimley-Horn and Associates

Construction Items

Item No.	Description	Quantity	Units	Unit Price	Cost
1	Excavation	822,500	CY	\$2	\$1,645,000
2	Airway Road culvert (6~5'wx5'h)	300	CY	\$1,500	\$450,000
3	La Media/Airway Road intersection culvert (6~10'wx6'h)	1,500	CY	\$1,500	\$2,250,000
4	Siempre Viva Road culvert (8~10'wx8'h)	1,490	CY	\$1,500	\$2,235,000
5	Detention Basin Outlet Structure	1	LS	\$100,000	\$100,000
6	Traffic Control	1	LS	\$100,000	\$100,000
7	Utility Relocation	1	LS	\$150,000	\$150,000
8	Street Repair	1	LS	\$50,000	\$50,000
9	Erosion Control	1	LS	\$50,000	\$50,000
10	Revegetation	1	LS	\$600,000	\$600,000
		Subtotal			\$7,630,000
		Contingency	20%		\$1,526,000
		Total			\$9,156,000

Land Acquisition

1	Land Acquisition (outside MHPA)*	2,610,000	SF	\$4	\$10,440,000
2	Land Acquisition (inside MHPA)**	1,820,000	SF	\$1	\$1,820,000
		Subtotal			\$12,260,000
		Contingency	20%		\$2,452,000
		Total			\$14,712,000

Total Cost (Construction and Land Acquisition)

\$23,868,000

Notes: * Includes area of detention basin and channel south of Siempre Viva

** Includes entire area within MHPA boundary

*** Estimate does not include engineering, environmental, geotechnical, surveying, etc.

OTAY MESA CPU

Earthwork Quantities

Cut: 822,500 CY

Fill: 900 CY

C = Cut depth in feet
F = Fill depth in feet

Detention Basin Volume: 308 AF

Max. Depth of Ponding: 6'

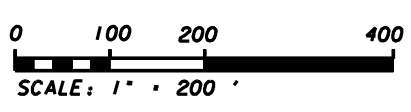
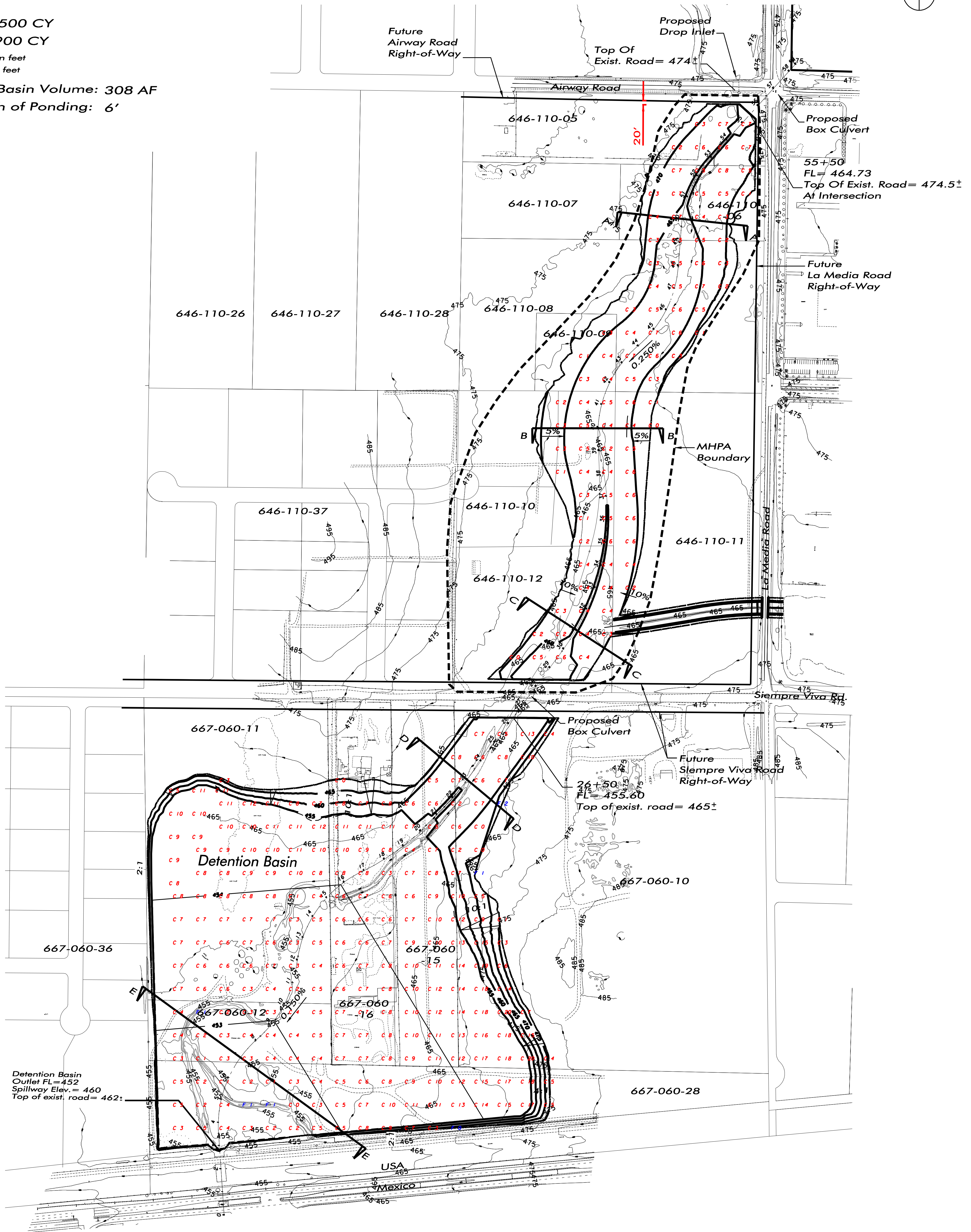

OTAY MESA CPU

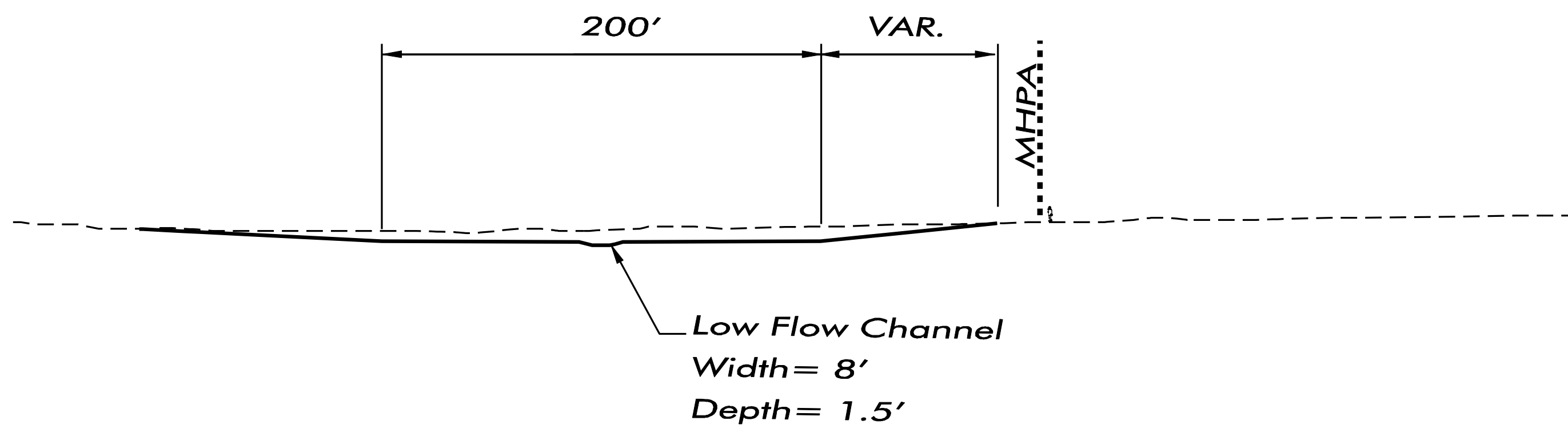

SECTION A-A

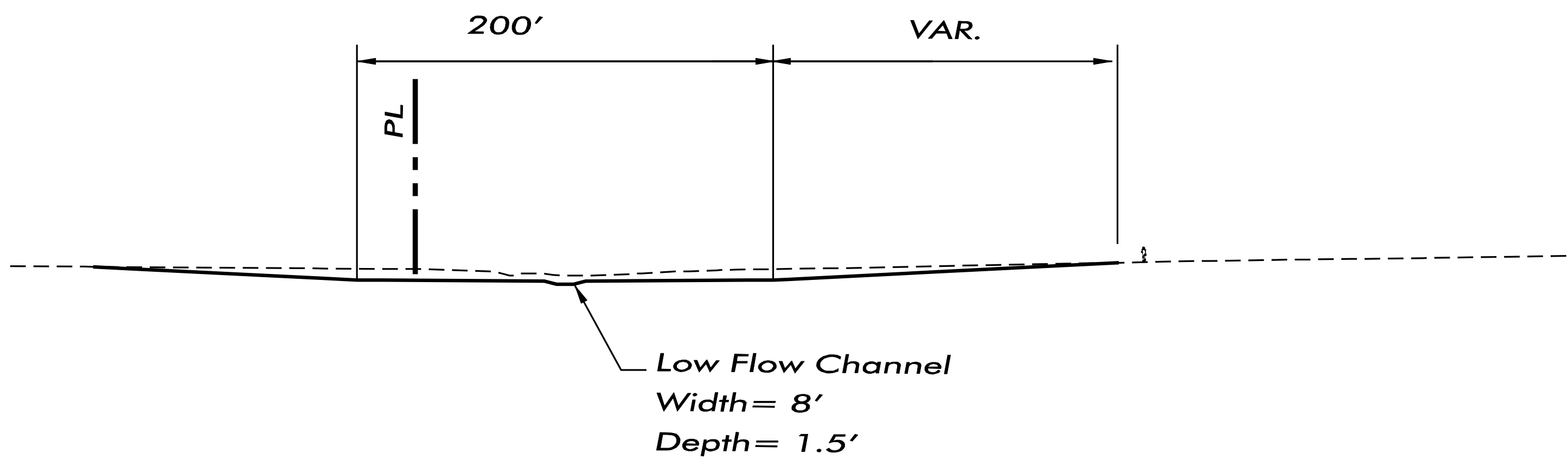

SECTION B-B

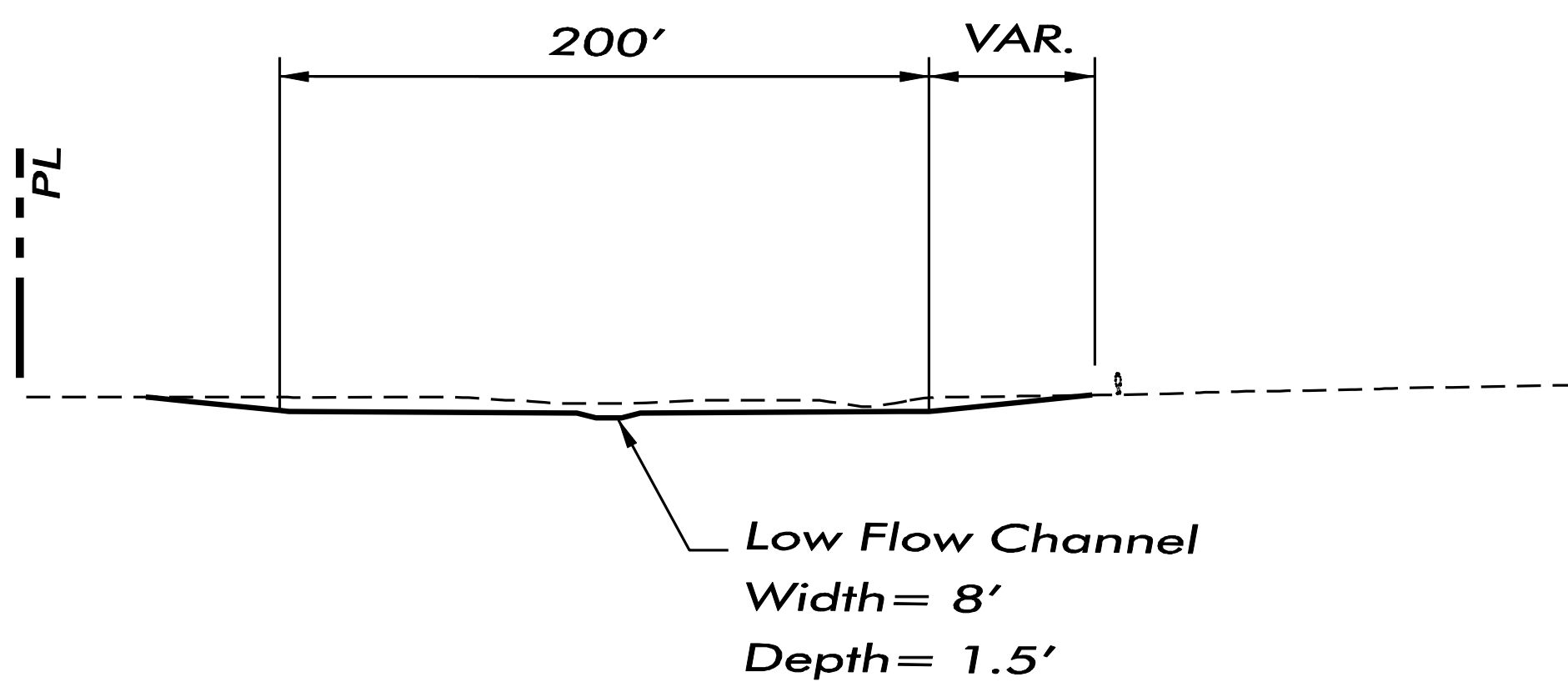

SECTION C-C

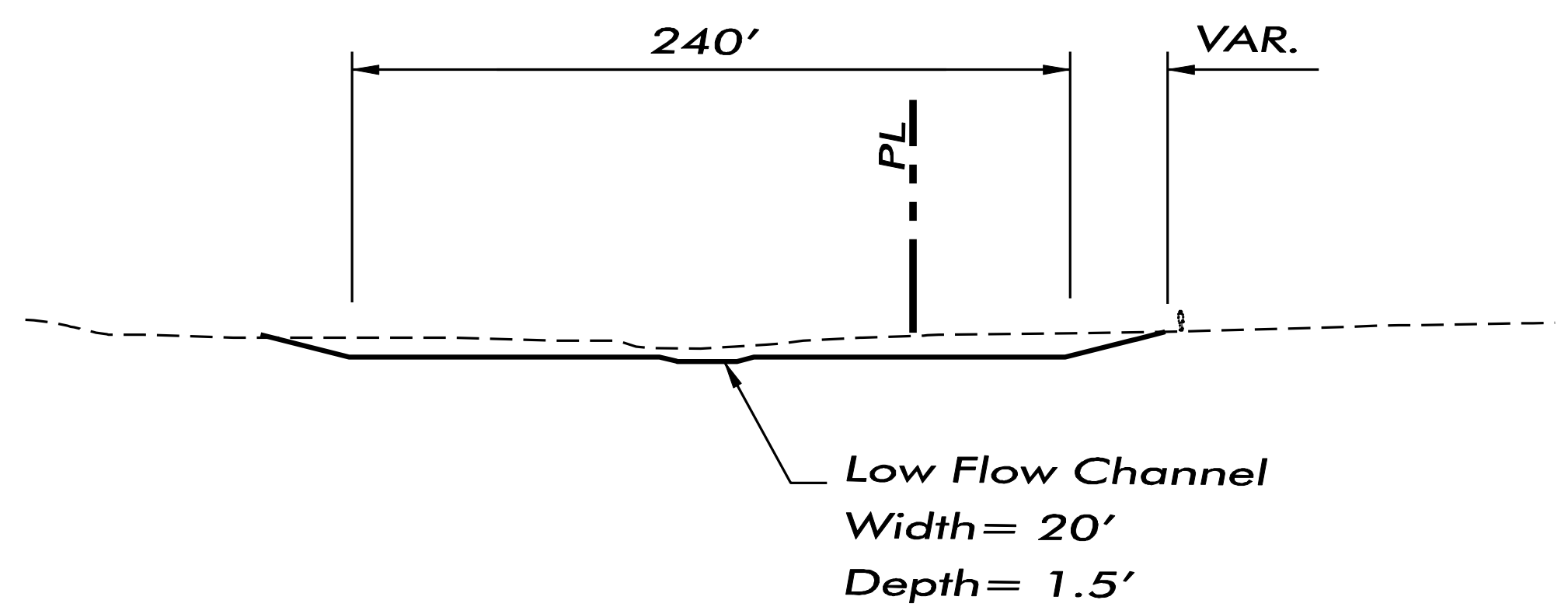

SECTION D-D

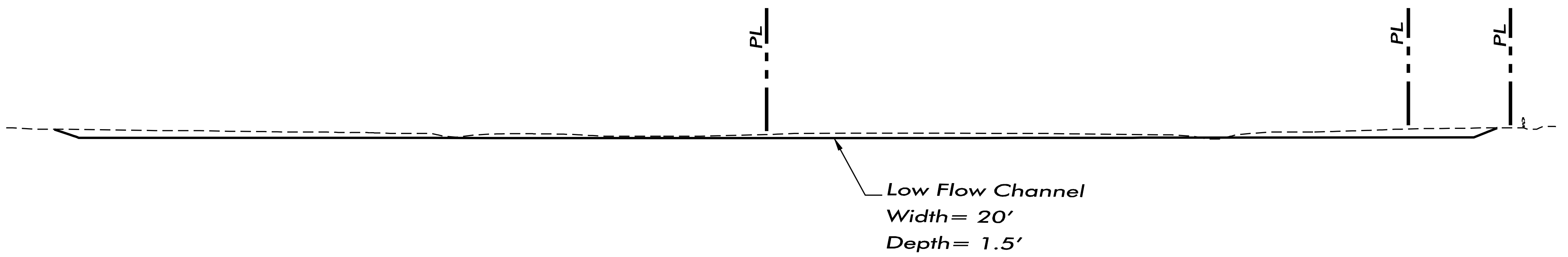





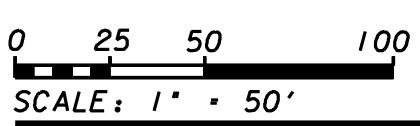

SECTION E-E

Note: No Vertical Exaggeration On Sections

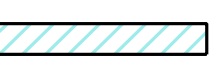

JUNE 2006

LEGEND

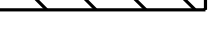
- FEDERAL PROPERTY 
- CITY OF SAN DIEGO PROPERTY 
- STATE OF CALIFORNIA PROPERTY 
- OTAY WATER DISTRICT PROPERTY 
- EXISTING DETENTION BASIN 
- WATERSHED BOUNDARY 
- OTAY MESA COMMUNITY PLAN BOUNDARY 
- PROPERTY IN THE COUNTY OF SAN DIEGO (565.8 AC.) 
- PROPERTY WITH EXISTING/APPROVED DETENTION (1095.4 AC.) 

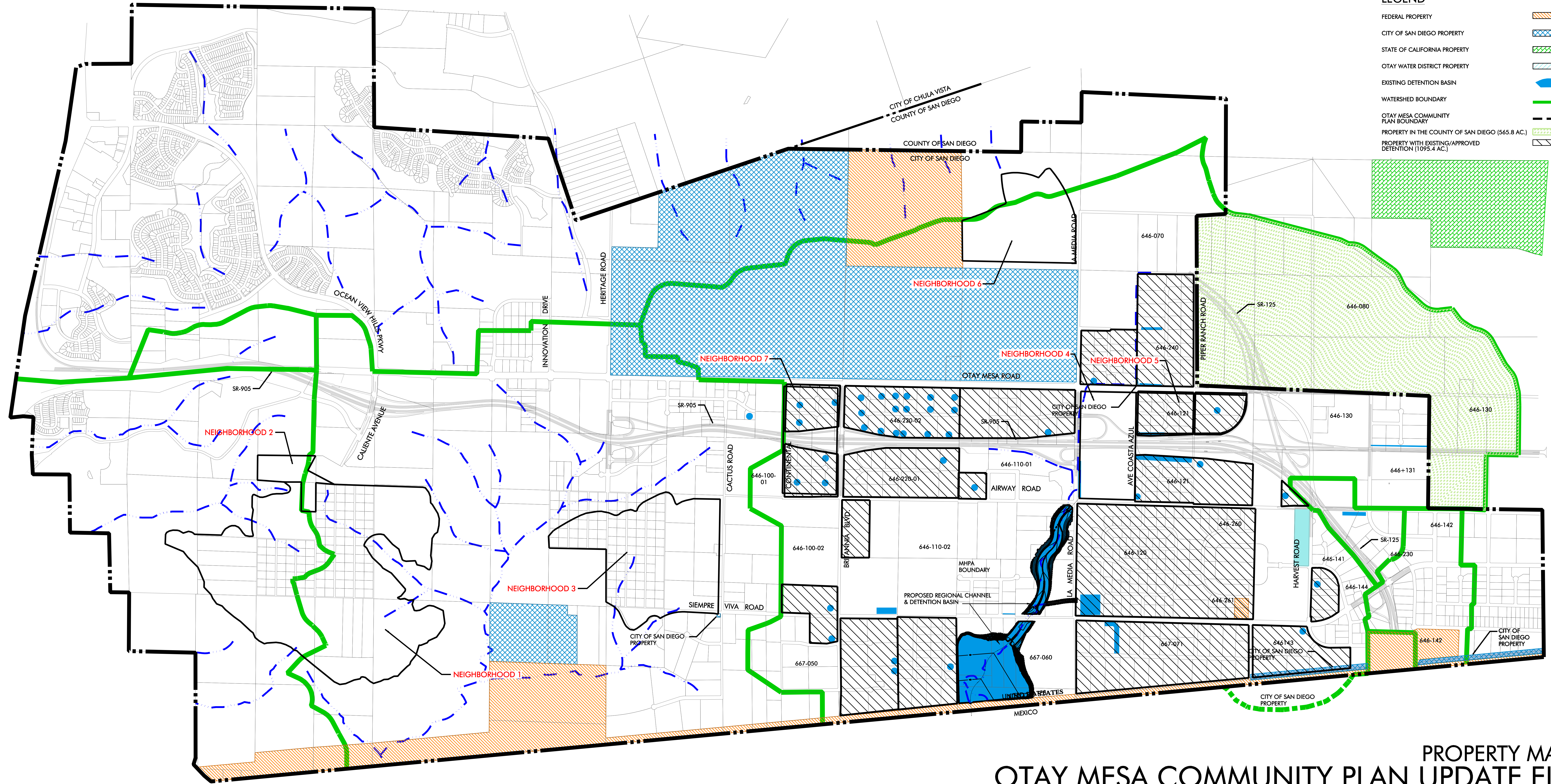

PROJECT NO. 03-027-0003 - OTAY MESA WATER TREATMENT PLANT - PRELIMINARY ENGINEERING

VII. RECOMMENDED DRAINAGE DESIGN CRITERIA

Since the five watershed areas on the Mesa flow in every direction except east, they flow into different watersheds with different constraints and impacts. The runoff from the five watersheds will have different criteria for design of drainage facilities.

West Perimeter Watershed

This watershed consists of smaller Mesa-top watersheds with a total area of approximately 254 acres that drain to the west to three separate creeks in canyons and gullies. These creeks are carried under the SD&AE and Trolley tracks and through San Ysidro in buried storm drain systems. The storm drains under the tracks have hydraulic capacities of 30 cfs (18" RCP) and 125 cfs (36" RCP) based on the San Ysidro Boulevard Area Master Drainage plan prepared by BSI Consultants, February 15, 1996. Sub-basins OT3-7 and OT3-8 combine downstream into a single creek that flows to the 36" RCP. The current study estimates 140 cfs (Q100) will flow off of the Mesa into this sub-basin. This study does not address the capacity of the downstream system or include the hydrologic analysis for areas to the west of the Mesa, but clearly the 125 cfs capacity of the existing system will be exceeded. This area will need to be addressed in more detail during design of the upstream tributary development. Detention Basins are recommended which will reduce peak flows in the sub-basin to minimize impacts on the downstream system. These detention basins will reduce the peak, 50-year, and 100-year flow to predevelopment levels. Because of the unstable soils in this area, care should be taken that the proposed detention basins and relocated drainage facilities do not contribute to an increase in the risk of slides through increased saturation of the soil.

West Watershed

The West Watershed consists of smaller Mesa-top watersheds that drain into the tributary canyons of Spring Canyon. All of the flow from the watershed flows into Mexico at the Spring Canyon concentration point. Detention basins will be required to reduce the post-development peak flows to predevelopment levels for the 50-year and 100-year storm. If the detention basins concentrate flows at the upper edge of canyons, care must be taken to ensure that erosion potential is not increased downstream.

East Watershed

The East Watershed flows to Mexico at a single concentration point between Britannia and La Media roads. Requirements for the control of peak runoff from development in this watershed already exist. The "Notice" dated August 7, 1987 (page 2), sets criteria for detention basins and for storm drain sizing. As part of the future storm drain project in this watershed, a single detention basin will be constructed at the border. The construction of this basin will eliminate the need for individual on-site detention basins for subsequent development.

North Perimeter Watershed

These small watersheds along the northern edge of the Mesa flow into small canyons that flow into the Otay River. There are no peak flow attenuation requirements for flows from these watersheds. There may be water quality issues with the Otay River, and there may be erosion issues from storm drains on the Mesa. Only approximately 14 acres of Neighborhood 6 are in this watershed.

VIII. STORM WATER QUALITY REQUIREMENTS

Because of problems related to the poor water quality of storm water runoff from urban conveyance systems, the City requires that storm water Best Management Practices (BMPs) be constructed for all new projects. The storm water discharge contains pollution such as chemicals, trash, sediment, bacteria, metals, oil and grease. Construction projects which add impervious areas and change drainage patterns increase the discharge of these pollutants.

The Municipal Storm Water National Pollutant Discharge Elimination System Permit (NPDES Municipal Permit), approved February 21, 2001 by the San Diego Regional Water Quality Control Board (RWQCB), requires the City to implement regulations for constructing storm water BMPs for development projects.

In 2003, as part of the San Diego Municipal Code, the City published “Storm Water Standards – A Manual for Construction & Permanent Storm Water Best Management Practices Requirements.” This manual is the reference document for all of the storm water issues encountered in development, including BMPs. Included in this report are Appendix C – Example Permanent Storm Water Best Management Practices, and the Storm Water Requirements Applicability Checklist from the City’s Manual. Before preparing a drainage study, the “Storm Water Requirements Applicability Checklist” is completed. This checklist is used to determine the priority level of the project. Most of the projects on the Mesa will require Priority Project Permanent Storm Water BMPs and High Priority Construction Storm Water BMPs.

All projects subject to the priority permanent BMP requirements must include a “Water Quality Technical Report.” From the manual, the report will include:

1. A drainage study report prepared by a civil engineer, hydrologist, or hydrogeologist registered in the State of California, with experience in the science of stream and river generated surface features (i.e., fluvial geomorphology) and water resources management, satisfactory to the City Engineer. The report shall consider the project area’s location (from the larger watershed perspective), topography, soil and vegetation conditions, percent impervious area, natural and infrastructure drainage features, and any other relevant hydrologic and environmental factors to be protected specific to the project area’s watershed.
2. A field reconnaissance to observe and report on downstream conditions, including undercutting erosion, slope stability, vegetative stress (due to flooding, erosion, water quality degradation, or loss of water supplies) and the area’s susceptibility to erosion or habitat alteration as a result of any future upstream development.
3. A hydrologic analysis to include rainfall runoff characteristics from the project area including at a minimum, peak runoff, time of concentration, and detention volume (if appropriate). These characteristics shall be developed for the two-year and ten-year frequency, six-hour or 24-hour, type B storm for the coastal areas of San Diego County. The largest peak flow should be included in the report. The report shall also report the project’s conditions of concern based on the hydrologic and downstream conditions discussed above. Where downstream conditions of concern have been identified, the drainage study shall establish that pre-project hydrologic conditions that minimize impacts on those downstream conditions of concern would be either improved or maintained by the proposed project, satisfactory to the City Engineer, by incorporating the permanent BMP requirements.

Appendix D of the Manual includes detailed guidelines for the Water Quality Technical Report.

There are numerous alternative permanent BMPs that can be used for each project. The alternatives include Site Design BMPs, Source Control BMPs, and Treatment Control BMPs. The Site Design BMPs are primary ways to reduce storm water runoff through means such as increased pervious areas, increased infiltration, use of natural channels, and appropriate landscaping. All of these except dry wells are applicable to the Mesa. Source Control BMPs are meant to control pollutants at their source before they enter storm water, and are all applicable to the Mesa. Treatment Control BMPs treat the storm water before it leaves the property, and include natural methods such as biofilters, detention basins, wetlands, and porous pavement, and mechanical methods such as filters and separators. The one Treatment Control BMP that is not applicable to the Mesa is infiltration, which is not very effective on the Mesa because of the clay soils.

Most of Otay Mesa drains to the south across the border with Mexico and eventually into the Tijuana River. A small portion flows north into the Otay River, and the far western part of the Mesa flows to the west through San Ysidro and then into the Tijuana River. The Tijuana River has been identified by the 2002 Clean Water Act as a “Section 303(d) Water Quality Limited” river. The pollutants of concern which are included in the attached pages from the USEPA, need to be listed, and the new development project’s potential impacts on these pollutants need to be included in the project’s drainage report.

Recommended Storm Water Policies

- 1. Apply water quality protection measures to land development projects during project design, permitting, construction, and operations in order to minimize the quantity of runoff generated on-site, the disruption of natural water flows and the contamination of storm water runoff.**
 - a. Increase on-site infiltration, and preserve, restore or incorporate natural drainage systems into site design
 - b. Reduce the amount of impervious surfaces through selection of materials, site planning, and narrowing street widths where possible.
 - c. Increase the use of natural vegetation and landscaping in drainage design.
 - d. Avoid conversion of areas particularly susceptible to erosion and sediment loss (e.g.: steep slopes), and where unavoidable, enforce regulations that minimize these impacts.
 - e. Avoid land use, site development, and zoning regulations that limit impacts on, and protect the natural integrity of topography, drainage systems, and water bodies.
 - f. Maintain landscape design standards that minimize the use of pesticides and herbicides.
 - g. Enforce maintenance requirements in development permit conditions.

- 2. Require construction contractors to comply with accepted storm water pollution prevention planning practices for all projects.**
 - a. Minimize the amount of graded land surface exposed to erosion and enforce control ordinances
 - b. Continue routine inspection practices to check for proper erosion control methods and housekeeping practices during construction.
 - c. Ensure that contractors are aware of and implement urban runoff control programs.

- 3. Encourage measures to promote the proper collection and disposal of pollutants at the source, rather than allowing them to enter the storm drain system.**
 - a. Promote the provision of used oil recycling and/or hazardous waste recycling facilities and drop-off locations.
 - b. Follow up on complaints of illegal discharges and accidental spills to storm drains, waterways, and canyons.

APPENDIX C

EXAMPLE PERMANENT STORM WATER BEST MANAGEMENT PRACTICES

The following are a list of BMPs may be used to minimize the introduction of pollutants of concern that may result in significant impacts to receiving waters. Other BMPs approved by the Development Services Department as being equal or more effective in pollutant reduction than comparable BMPs identified below are acceptable. All BMPs must comply with local zoning and building codes and other applicable regulations.

Site Design BMPs

Minimizing Impervious Areas

- Reduce sidewalk widths
- Incorporate landscaped buffer areas between sidewalks and streets.
- Design residential streets for the minimum required pavement widths
- Minimize the number of residential street cul-de-sacs and incorporate landscaped areas to reduce their impervious cover.
- Use open space development that incorporates smaller lot sizes
- Increase building density while decreasing the building footprint
- Reduce overall lot imperviousness by promoting alternative driveway surfaces and shared driveways that connect two or more homes together
- Reduce overall imperviousness associated with parking lots by providing compact car spaces, minimizing stall dimensions, incorporating efficient parking lanes, and using pervious materials in spillover parking areas

Increase Rainfall Infiltration

- Use permeable materials for private sidewalks, driveways, parking lots, and interior roadway surfaces (examples: hybrid lots, parking groves, permeable overflow parking, etc.)
- Direct rooftop runoff to pervious areas such as yards, open channels, or vegetated areas, and avoid routing rooftop runoff to the roadway or the urban runoff conveyance system

Maximize Rainfall Interception

- Maximizing canopy interception and water conservation by preserving existing native trees and shrubs, and planting Additional native or drought tolerant trees and large shrubs.

Minimize Directly Connected Impervious Areas (DCIAs)

- Draining rooftops into adjacent landscaping prior to discharging to the storm water conveyance system

- Draining parking lots into landscape areas co-designed as biofiltration areas
- Draining roads, sidewalks, and impervious trails into adjacent landscaping

Slope and Channel Protection

Use of natural drainage systems to the maximum extent practicable

- Stabilized permanent channel crossings
- Planting native or drought tolerant vegetation on slopes
- Energy dissipaters, such as riprap, at the outlets of new storm drains, culverts, conduits, or channels that enter unlined Channels

Maximize Rainfall Interception

- Cisterns
- Foundation planting

Increase Rainfall Infiltration

- Dry wells

Source Control BMPs

- Storm water conveyance system stenciling and signage
- Outdoor material and trash storage area designed to reduce or control rainfall runoff
- Efficient irrigation system

Treatment Control BMPs

Biofilters

- Grass swale
- Grass strip
- Wetland vegetation swale
- Bioretention

Detention Basins

- Extended/dry detention basin with grass lining
- Extended/dry detention basin with impervious lining

Infiltration

- Infiltration basin
- Infiltration trench

Pervious Paving

- Porous asphalt
- Porous concrete
- Porous modular concrete block

Wet Ponds and Wetlands

- Wet pond (permanent pool)
- Constructed wetland

Drainage Inserts

- Catch basin/storm drain inserts
- Catch basin screens

Filtration Systems

- Media filtration
- Sand filtration

Hydrodynamic Separation Systems

- Swirl concentrator
- Cyclone separator
- Baffle boxes



City of San Diego
 Development Services
 1222 First Ave., MS-302
 San Diego, CA 92101
 (619) 446-5000 for information

Storm Water Requirements Applicability Checklist

THE CITY OF SAN DIEGO

Project Address:	Assessor Parcel Number(s):	Project Number (for City Use Only)
------------------	----------------------------	------------------------------------

Complete Sections 1 and 2 of the following checklist to determine your project's permanent and construction storm water best management practices requirements. This form must be completed and submitted with your permit application.

Section 1 - Permanent Storm Water BMP Requirements:

If any answers to Part A are answered "Yes," your project is subject to the "Priority Project Permanent Storm Water BMP Requirements," and "Standard Permanent Storm Water BMP Requirements" of the Storm Water Standards Manual, Section III, "Permanent Storm Water BMP Selection Procedure." If all answers to Part A are "No," and any answers to Part B are "Yes," your project is only subject to the Standard Permanent Storm Water BMP Requirements. If every question in Part A and B is answered "No," your project is exempt from permanent storm water requirements.

Part A: Determine Priority Project Permanent Storm Water BMP Requirements.

Does the project meet the definition of one or more of the priority project categories?*

- | | | |
|--|-----|----|
| 1. Detached residential development of 10 or more units | Yes | No |
| 2. Attached residential development of 10 or more units | Yes | No |
| 3. Commercial development greater than 100,000 square feet | Yes | No |
| 4. Automotive repair shop | Yes | No |
| 5. Restaurant | Yes | No |
| 6. Steep hillside development greater than 5,000 square feet | Yes | No |
| 7. Project discharging to receiving waters within Water Quality Sensitive Areas | Yes | No |
| 8. Parking lots greater than or equal to 5,000 square feet or with at least 15 parking spaces, and potentially exposed to urban runoff | Yes | No |
| 9. Streets, roads, highways, and freeways which would create a new paved surface that is 5,000 square feet or greater | Yes | No |
| 10. Significant redevelopment over 5,000 square feet | Yes | No |

* Refer to the definitions section in the Storm Water Standards for expanded definitions of the priority project categories.

Limited Exclusion: Trenching and resurfacing work associated with utility projects are not considered priority projects. Parking lots, buildings and other structures associated with utility projects are priority projects if one or more of the criteria in Part A is met. If all answers to Part A are "No", continue to Part B.

Part B: Determine Standard Permanent Storm Water Requirements.

Does the project propose:

- | | | |
|--|-----|----|
| 1. New impervious areas, such as rooftops, roads, parking lots, driveways, paths and sidewalks? | Yes | No |
| 2. New pervious landscape areas and irrigation systems? | Yes | No |
| 3. Permanent structures within 100 feet of any natural water body? | Yes | No |
| 4. Trash storage areas? | Yes | No |
| 5. Liquid or solid material loading and unloading areas? | Yes | No |
| 6. Vehicle or equipment fueling, washing, or maintenance areas? | Yes | No |
| 7. Require a General NPDES Permit for Storm Water Discharges Associated with Industrial Activities (Except construction)?* | Yes | No |
| 8. Commercial or industrial waste handling or storage, excluding typical office or household waste? | Yes | No |
| 9. Any grading or ground disturbance during construction? | Yes | No |
| 10. Any new storm drains, or alteration to existing storm drains? | Yes | No |

*To find out if your project is required to obtain an individual General NPDES Permit for Storm Water Discharges Associated with Industrial Activities, visit the State Water Resources Control Board web site at, www.swrcb.ca.gov/stormwtr/industrial.html

Printed on recycled paper. This information is available in alternative formats for persons with disabilities.

To request this document in alternative format, call (619) 446-5446 or (800) 735-2929 (TT).

Be sure to see us on the WorldWide Web at www.sandiego.gov/development-services

Section 2. Construction Storm Water BMP Requirements:

If the answer to question 1 of Part C is answered "Yes," your project is subject to Section IV of the Storm Water Standards Manual, "Construction Storm Water BMP Performance Standards," and must prepare a Storm Water Pollution Prevention Plan (SWPPP). If the answer to question 1 of Part C is "No," but the answer to any of the remaining questions is "Yes," your project is subject to Section IV of the Storm Water Standards Manual, "Construction Storm Water BMP Performance Standards," and must prepare a Water Pollution Control Plan (WPCP). If every question in Part C is answered "No," your project is exempt from any construction storm water BMP requirements. If any of the answers to the questions in Part C are "Yes," complete the construction site prioritization in Part D below.

Part C: Determine Construction Phase Storm Water Requirements.

Would the project meet any of these criteria during construction?

1. Is the project subject to California's statewide General NPDES Permit for Storm Water Discharges Associated With Construction Activities? Yes No
2. Does the project propose grading or soil disturbance? Yes No
3. Would storm water or urban runoff have the potential to contact any portion of the construction area, including washing and staging areas? Yes No
4. Would the project use any construction materials that could negatively affect water quality if discharged from the site (such as, paints, solvents, concrete, and stucco)? Yes No

Part D: Determine Construction Site Priority

In accordance with the Municipal Permit, each construction site with construction storm water BMP requirements must be designated with a priority: high, medium or low. This prioritization must be completed with this form, noted on the plans, and included in the SWPPP or WPCP. Indicate the project's priority in one of the check boxes using the criteria below, and existing and surrounding conditions of the project, the type of activities necessary to complete the construction and any other extenuating circumstances that may pose a threat to water quality. The City reserves the right to adjust the priority of the projects both before and during construction. [Note: The construction priority does NOT change construction BMP requirements that apply to projects; all construction BMP requirements must be identified on a case-by-case basis. The construction priority does affect the frequency of inspections that will be conducted by City staff. See Section IV.1 for more details on construction BMP requirements.]

1) High Priority

- a) Projects where the site is 50 acres or more and grading will occur during the wet season
- b) Projects 5 acres or more and tributary to an impaired water body for sediment (e.g., Peñasquitos watershed)
- c) Projects 5 acres or more within or directly adjacent to or discharging directly to a coastal lagoon or other receiving water within an environmentally sensitive area
- d) Projects, active or inactive, adjacent or tributary to sensitive water bodies

2) Medium Priority

- a) Capital Improvement Projects where grading occurs, however a Storm Water Pollution Prevention Plan (SWPPP) is not required under the State General Construction Permit (i.e., water and sewer replacement projects, intersection and street re-alignments, widening, comfort stations, etc.)
- b) Permit projects in the public right-of-way where grading occurs, however SWPPPs are not required, such as installation of sidewalk, substantial retaining walls, curb and gutter for an entire street frontage, etc.
- c) Permit projects on private property where grading permits are required (i.e., cuts over 5 feet, fills over 3 feet), however, Notice Of Intents (NOIs) and SWPPPs are not required.

3) Low Priority

- a) Capital Projects where minimal to no grading occurs, such as signal light and loop installations, street light installations, etc.
- b) Permit projects in the public right-of-way where minimal to no grading occurs, such as pedestrian ramps, driveway additions, small retaining walls, etc.
- c) Permit projects on private property where grading permits are not required, such as small retaining walls, single-family homes, small tenant improvements, etc.

Name of Owner or Agent (Please Print):

Title:

Signature:

Date:

APPENDICES

Appendix A

- AES Hydrology Calculations

RATIONAL METHOD HYDROLOGY COMPUTER PROGRAM PACKAGE
Reference: SAN DIEGO COUNTY FLOOD CONTROL DISTRICT
2003, 1985, 1981 HYDROLOGY MANUAL

(c) Copyright 1982-2003 Advanced Engineering Software (aes)
Ver. 1.5A Release Date: 01/01/2003 License ID 1499

Analysis prepared by:

Kimley-Horn and Associates San Diego
517 4th Avenue Suite 301
San Diego, California 92101
(619) 234-9411 Fax (619) 234-9433

***** DESCRIPTION OF STUDY *****

- * Otay Mesa Watershed Analysis *
 - * 50 Year Storm Event P=1.70 *
 - * 5/12/05 AMC *
- *****

FILE NAME: C:\Drainage\407000\OT3-1.DAT
TIME/DATE OF STUDY: 08:03 05/12/2005

USER SPECIFIED HYDROLOGY AND HYDRAULIC MODEL INFORMATION:

1985 SAN DIEGO MANUAL CRITERIA

USER SPECIFIED STORM EVENT (YEAR) = 50.00
6-HOUR DURATION PRECIPITATION (INCHES) = 1.700
SPECIFIED MINIMUM PIPE SIZE (INCH) = 18.00
SPECIFIED PERCENT OF GRADIENTS (DECIMAL) TO USE FOR FRICTION SLOPE = 1.00
SAN DIEGO HYDROLOGY MANUAL "C"-VALUES USED FOR RATIONAL METHOD
NOTE: ONLY PEAK CONFLUENCE VALUES CONSIDERED

USER-DEFINED STREET-SECTIONS FOR COUPLED PIPEFLOW AND STREETFLOW MODEL

NO.	HALF- CROWN TO STREET-CROSSFALL:			CURB GUTTER-GEOMETRIES:				MANNING FACTOR (n)
	WIDTH (FT)	CROSSFALL (FT)	IN- / OUT- / SIDE / SIDE / WAY	HEIGHT (FT)	WIDTH (FT)	LIP (FT)	HIKE (FT)	
1	30.0	20.0	0.018/0.018/0.020	0.67	2.00	0.0312	0.167	0.0150

GLOBAL STREET FLOW-DEPTH CONSTRAINTS:

1. Relative Flow-Depth = 0.00 FEET
as (Maximum Allowable Street Flow Depth) - (Top-of-Curb)
 2. (Depth)*(Velocity) Constraint = 6.0 (FT*FT/S)
- *SIZE PIPE WITH A FLOW CAPACITY GREATER THAN OR EQUAL TO THE UPSTREAM TRIBUTARY PIPE.*

FLOW PROCESS FROM NODE 3100.00 TO NODE 3101.00 IS CODE = 21

>>>>RATIONAL METHOD INITIAL SUBAREA ANALYSIS<<<<<

=====

GRASS FAIR COVER RUNOFF COEFFICIENT = .4500
SOIL CLASSIFICATION IS "D"
S.C.S. CURVE NUMBER (AMC II) = 84

NATURAL WATERSHED NOMOGRAPH TIME OF CONCENTRATION (APPENDIX X-A)
WITH 10-MIN. ADDED = 10.86(MIN.)
INITIAL SUBAREA FLOW-LENGTH(FEET) = 70.00
UPSTREAM ELEVATION(FEET) = 106.00
DOWNSTREAM ELEVATION(FEET) = 104.32
ELEVATION DIFFERENCE(FEET) = 1.68
NATURAL WATERSHED TIME OF CONCENTRATION = 10.86
50 YEAR RAINFALL INTENSITY(INCH/HOUR) = 2.715
SUBAREA RUNOFF(CFS) = 0.12
TOTAL AREA(ACRES) = 0.10 TOTAL RUNOFF(CFS) = 0.12

FLOW PROCESS FROM NODE 3101.00 TO NODE 3102.00 IS CODE = 51

>>>>COMPUTE TRAPEZOIDAL CHANNEL FLOW<<<<<
>>>>TRAVELTIME THRU SUBAREA (EXISTING ELEMENT)<<<<<

=====

CHANNEL LENGTH THRU SUBAREA(FEET)	=	180.00
REPRESENTATIVE CHANNEL SLOPE	=	0.0240
CHANNEL BASE(FEET)	=	10.00 "Z" FACTOR = 50.000
MANNING'S FACTOR	=	0.030 MAXIMUM DEPTH(FEET) = 2.00
CHANNEL FLOW THRU SUBAREA(CFS)	=	0.12
FLOW VELOCITY(FEET/SEC.)	=	0.55 FLOW DEPTH(FEET) = 0.02
TRAVEL TIME(MIN.)	=	5.41 Tc(MIN.) = 16.27
LONGEST FLOWPATH FROM NODE	3100.00 TO NODE	3102.00 = 250.00 FEET.

FLOW PROCESS FROM NODE 3102.00 TO NODE 3103.00 IS CODE = 81

>>>>ADDITION OF SUBAREA TO MAINLINE PEAK FLOW<<<<<

=====

50 YEAR RAINFALL INTENSITY(INCH/HOUR)	=	2.092
GRASS FAIR COVER RUNOFF COEFFICIENT	=	.4500
SOIL CLASSIFICATION IS	"D"	
S.C.S. CURVE NUMBER (AMC II)	=	84
SUBAREA AREA(ACRES)	=	19.30 SUBAREA RUNOFF(CFS) = 18.17
TOTAL AREA(ACRES)	=	19.40 TOTAL RUNOFF(CFS) = 18.29
TC(MIN.)	=	16.27

FLOW PROCESS FROM NODE 0.00 TO NODE 0.00 IS CODE = 13

>>>>CLEAR THE MAIN-STREAM MEMORY<<<<<

FLOW PROCESS FROM NODE 3110.00 TO NODE 3111.00 IS CODE = 21

>>>>RATIONAL METHOD INITIAL SUBAREA ANALYSIS<<<<<

=====

GRASS FAIR COVER RUNOFF COEFFICIENT	=	.4500
SOIL CLASSIFICATION IS	"D"	
S.C.S. CURVE NUMBER (AMC II)	=	84
NATURAL WATERSHED NOMOGRAPH TIME OF CONCENTRATION (APPENDIX X-A)		
WITH 10-MIN. ADDED	=	10.85(MIN.)
INITIAL SUBAREA FLOW-LENGTH(FEET)	=	70.00
UPSTREAM ELEVATION(FEET)	=	110.00

DOWNSTREAM ELEVATION (FEET) = 108.25
ELEVATION DIFFERENCE (FEET) = 1.75
NATURAL WATERSHED TIME OF CONCENTRATION = 10.85
50 YEAR RAINFALL INTENSITY (INCH/HOUR) = 2.717
SUBAREA RUNOFF (CFS) = 0.12
TOTAL AREA (ACRES) = 0.10 TOTAL RUNOFF (CFS) = 0.12

FLOW PROCESS FROM NODE 3111.00 TO NODE 3112.00 IS CODE = 51

>>>>COMPUTE TRAPEZOIDAL CHANNEL FLOW<<<<<
>>>>TRAVELTIME THRU SUBAREA (EXISTING ELEMENT)<<<<<

=====

CHANNEL LENGTH THRU SUBAREA (FEET) = 330.00
REPRESENTATIVE CHANNEL SLOPE = 0.0250
CHANNEL BASE (FEET) = 10.00 "Z" FACTOR = 50.000
MANNING'S FACTOR = 0.030 MAXIMUM DEPTH (FEET) = 2.00
CHANNEL FLOW THRU SUBAREA (CFS) = 0.12
FLOW VELOCITY (FEET/SEC.) = 0.55 FLOW DEPTH (FEET) = 0.02
TRAVEL TIME (MIN.) = 9.91 Tc (MIN.) = 20.76
LONGEST FLOWPATH FROM NODE 3110.00 TO NODE 3112.00 = 400.00 FEET.

FLOW PROCESS FROM NODE 3112.00 TO NODE 3113.00 IS CODE = 81

>>>>ADDITION OF SUBAREA TO MAINLINE PEAK FLOW<<<<<

=====

50 YEAR RAINFALL INTENSITY (INCH/HOUR) = 1.788
GRASS FAIR COVER RUNOFF COEFFICIENT = .4500
SOIL CLASSIFICATION IS "D"
S.C.S. CURVE NUMBER (AMC II) = 84
SUBAREA AREA (ACRES) = 14.70 SUBAREA RUNOFF (CFS) = 11.83
TOTAL AREA (ACRES) = 14.80 TOTAL RUNOFF (CFS) = 11.95
TC (MIN.) = 20.76

FLOW PROCESS FROM NODE 0.00 TO NODE 0.00 IS CODE = 13

>>>>CLEAR THE MAIN-STREAM MEMORY<<<<<

FLOW PROCESS FROM NODE 3200.00 TO NODE 3201.00 IS CODE = 21

>>>>RATIONAL METHOD INITIAL SUBAREA ANALYSIS<<<<<

=====

GRASS FAIR COVER RUNOFF COEFFICIENT = .4500
SOIL CLASSIFICATION IS "D"
S.C.S. CURVE NUMBER (AMC II) = 84
NATURAL WATERSHED NOMOGRAPH TIME OF CONCENTRATION (APPENDIX X-A)
WITH 10-MIN. ADDED = 10.86 (MIN.)
INITIAL SUBAREA FLOW-LENGTH (FEET) = 70.00
UPSTREAM ELEVATION (FEET) = 122.00
DOWNSTREAM ELEVATION (FEET) = 120.29
ELEVATION DIFFERENCE (FEET) = 1.71
NATURAL WATERSHED TIME OF CONCENTRATION = 10.86
50 YEAR RAINFALL INTENSITY (INCH/HOUR) = 2.716

SUBAREA RUNOFF(CFS) = 0.12
TOTAL AREA(ACRES) = 0.10 TOTAL RUNOFF(CFS) = 0.12

FLOW PROCESS FROM NODE 3201.00 TO NODE 3202.00 IS CODE = 51

>>>>COMPUTE TRAPEZOIDAL CHANNEL FLOW<<<<<
>>>>TRAVELTIME THRU SUBAREA (EXISTING ELEMENT)<<<<<

=====

CHANNEL LENGTH THRU SUBAREA(FEET)	=	830.00
REPRESENTATIVE CHANNEL SLOPE	=	0.0240
CHANNEL BASE(FEET)	=	10.00 "Z" FACTOR = 50.000
MANNING'S FACTOR	=	0.030 MAXIMUM DEPTH(FEET) = 2.00
CHANNEL FLOW THRU SUBAREA(CFS)	=	0.12
FLOW VELOCITY(FEET/SEC.)	=	0.55 FLOW DEPTH(FEET) = 0.02
TRAVEL TIME(MIN.)	=	24.94 Tc(MIN.) = 35.80
LONGEST FLOWPATH FROM NODE	3200.00 TO NODE	3202.00 = 900.00 FEET.

FLOW PROCESS FROM NODE 3202.00 TO NODE 3203.00 IS CODE = 81

>>>>ADDITION OF SUBAREA TO MAINLINE PEAK FLOW<<<<<

=====

50 YEAR RAINFALL INTENSITY(INCH/HOUR)	=	1.258
GRASS FAIR COVER RUNOFF COEFFICIENT	=	.4500
SOIL CLASSIFICATION IS	"D"	
S.C.S. CURVE NUMBER (AMC II)	=	84
SUBAREA AREA(ACRES)	=	47.00 SUBAREA RUNOFF(CFS) = 26.61
TOTAL AREA(ACRES)	=	47.10 TOTAL RUNOFF(CFS) = 26.74
TC(MIN.)	=	35.80

FLOW PROCESS FROM NODE 0.00 TO NODE 0.00 IS CODE = 13

>>>>CLEAR THE MAIN-STREAM MEMORY<<<<<

FLOW PROCESS FROM NODE 3300.00 TO NODE 3301.00 IS CODE = 21

>>>>RATIONAL METHOD INITIAL SUBAREA ANALYSIS<<<<<

=====

GRASS FAIR COVER RUNOFF COEFFICIENT	=	.4500
SOIL CLASSIFICATION IS	"D"	
S.C.S. CURVE NUMBER (AMC II)	=	84
NATURAL WATERSHED NOMOGRAPH TIME OF CONCENTRATION (APPENDIX X-A)		
WITH 10-MIN. ADDED	=	10.83(MIN.)
INITIAL SUBAREA FLOW-LENGTH(FEET)	=	70.00
UPSTREAM ELEVATION(FEET)	=	108.00
DOWNSTREAM ELEVATION(FEET)	=	106.13
ELEVATION DIFFERENCE(FEET)	=	1.87
NATURAL WATERSHED TIME OF CONCENTRATION	=	10.83
50 YEAR RAINFALL INTENSITY(INCH/HOUR)	=	2.721
SUBAREA RUNOFF(CFS)	=	0.12
TOTAL AREA(ACRES)	=	0.10 TOTAL RUNOFF(CFS) = 0.12

FLOW PROCESS FROM NODE 3201.00 TO NODE 3202.00 IS CODE = 51

>>>>COMPUTE TRAPEZOIDAL CHANNEL FLOW<<<<<
>>>>TRAVELTIME THRU SUBAREA (EXISTING ELEMENT)<<<<<

=====

CHANNEL LENGTH THRU SUBAREA (FEET) =	230.00
REPRESENTATIVE CHANNEL SLOPE =	0.0267
CHANNEL BASE (FEET) =	10.00
"Z" FACTOR =	50.000
MANNING'S FACTOR =	0.030
MAXIMUM DEPTH (FEET) =	2.00
CHANNEL FLOW THRU SUBAREA (CFS) =	0.12
FLOW VELOCITY (FEET/SEC.) =	0.56
FLOW DEPTH (FEET) =	0.02
TRAVEL TIME (MIN.) =	6.90
Tc (MIN.) =	17.73
LONGEST FLOWPATH FROM NODE 3300.00 TO NODE 3202.00 =	300.00 FEET.

FLOW PROCESS FROM NODE 3302.00 TO NODE 3303.00 IS CODE = 81

>>>>ADDITION OF SUBAREA TO MAINLINE PEAK FLOW<<<<<

=====

50 YEAR RAINFALL INTENSITY (INCH/HOUR) =	1.980
GRASS FAIR COVER RUNOFF COEFFICIENT =	.4500
SOIL CLASSIFICATION IS	"D"
S.C.S. CURVE NUMBER (AMC II) =	84
SUBAREA AREA (ACRES) =	11.70
SUBAREA RUNOFF (CFS) =	10.42
TOTAL AREA (ACRES) =	11.80
TOTAL RUNOFF (CFS) =	10.55
TC (MIN.) =	17.73

FLOW PROCESS FROM NODE 0.00 TO NODE 0.00 IS CODE = 13

>>>>CLEAR THE MAIN-STREAM MEMORY<<<<<

FLOW PROCESS FROM NODE 3400.00 TO NODE 3401.00 IS CODE = 21

>>>>RATIONAL METHOD INITIAL SUBAREA ANALYSIS<<<<<

=====

GRASS FAIR COVER RUNOFF COEFFICIENT =	.4500
SOIL CLASSIFICATION IS	"D"
S.C.S. CURVE NUMBER (AMC II) =	84
NATURAL WATERSHED NOMOGRAPH TIME OF CONCENTRATION (APPENDIX X-A)	
WITH 10-MIN. ADDED =	10.84 (MIN.)
INITIAL SUBAREA FLOW-LENGTH (FEET) =	70.00
UPSTREAM ELEVATION (FEET) =	118.00
DOWNSTREAM ELEVATION (FEET) =	116.20
ELEVATION DIFFERENCE (FEET) =	1.80
NATURAL WATERSHED TIME OF CONCENTRATION =	10.84
50 YEAR RAINFALL INTENSITY (INCH/HOUR) =	2.719
SUBAREA RUNOFF (CFS) =	0.12
TOTAL AREA (ACRES) =	0.10
TOTAL RUNOFF (CFS) =	0.12

FLOW PROCESS FROM NODE 3401.00 TO NODE 3402.00 IS CODE = 51

>>>>COMPUTE TRAPEZOIDAL CHANNEL FLOW<<<<<
>>>>TRAVELTIME THRU SUBAREA (EXISTING ELEMENT)<<<<<

```

=====
CHANNEL LENGTH THRU SUBAREA( FEET) = 630.00
REPRESENTATIVE CHANNEL SLOPE = 0.0257
CHANNEL BASE( FEET) = 10.00 "Z" FACTOR = 50.000
MANNING'S FACTOR = 0.030 MAXIMUM DEPTH( FEET) = 2.00
CHANNEL FLOW THRU SUBAREA( CFS) = 0.12
FLOW VELOCITY( FEET/SEC.) = 0.56 FLOW DEPTH( FEET) = 0.02
TRAVEL TIME( MIN.) = 18.91 Tc( MIN.) = 29.75
LONGEST FLOWPATH FROM NODE 3400.00 TO NODE 3402.00 = 700.00 FEET.

*****
FLOW PROCESS FROM NODE 3402.00 TO NODE 3403.00 IS CODE = 81
-----
>>>>ADDITION OF SUBAREA TO MAINLINE PEAK FLOW<<<<<
=====
50 YEAR RAINFALL INTENSITY( INCH/HOUR) = 1.418
GRASS FAIR COVER RUNOFF COEFFICIENT = .4500
SOIL CLASSIFICATION IS "D"
S.C.S. CURVE NUMBER (AMC II) = 84
SUBAREA AREA( ACRES) = 34.90 SUBAREA RUNOFF( CFS) = 22.27
TOTAL AREA( ACRES) = 35.00 TOTAL RUNOFF( CFS) = 22.39
TC( MIN.) = 29.75

*****
FLOW PROCESS FROM NODE 0.00 TO NODE 0.00 IS CODE = 13
-----
>>>>CLEAR THE MAIN-STREAM MEMORY<<<<<
=====

*****
FLOW PROCESS FROM NODE 3500.00 TO NODE 3501.00 IS CODE = 21
-----
>>>>RATIONAL METHOD INITIAL SUBAREA ANALYSIS<<<<<
=====
GRASS FAIR COVER RUNOFF COEFFICIENT = .4500
SOIL CLASSIFICATION IS "D"
S.C.S. CURVE NUMBER (AMC II) = 84
NATURAL WATERSHED NOMOGRAPH TIME OF CONCENTRATION (APPENDIX X-A)
WITH 10-MIN. ADDED = 10.85( MIN.)
INITIAL SUBAREA FLOW-LENGTH( FEET) = 70.00
UPSTREAM ELEVATION( FEET) = 110.00
DOWNSTREAM ELEVATION( FEET) = 108.25
ELEVATION DIFFERENCE( FEET) = 1.75
NATURAL WATERSHED TIME OF CONCENTRATION = 10.85
50 YEAR RAINFALL INTENSITY( INCH/HOUR) = 2.717
SUBAREA RUNOFF( CFS) = 0.12
TOTAL AREA( ACRES) = 0.10 TOTAL RUNOFF( CFS) = 0.12

*****
FLOW PROCESS FROM NODE 3501.00 TO NODE 3502.00 IS CODE = 51
-----
>>>>COMPUTE TRAPEZOIDAL CHANNEL FLOW<<<<<
>>>>TRAVELTIME THRU SUBAREA (EXISTING ELEMENT)<<<<<
=====
CHANNEL LENGTH THRU SUBAREA( FEET) = 330.00
REPRESENTATIVE CHANNEL SLOPE = 0.0250
CHANNEL BASE( FEET) = 10.00 "Z" FACTOR = 50.000

```

MANNING'S FACTOR = 0.030 MAXIMUM DEPTH (FEET) = 2.00
CHANNEL FLOW THRU SUBAREA (CFS) = 0.12
FLOW VELOCITY (FEET/SEC.) = 0.55 FLOW DEPTH (FEET) = 0.02
TRAVEL TIME (MIN.) = 9.91 Tc (MIN.) = 20.76
LONGEST FLOWPATH FROM NODE 3500.00 TO NODE 3502.00 = 400.00 FEET.

FLOW PROCESS FROM NODE 3502.00 TO NODE 3503.00 IS CODE = 81

>>>>ADDITION OF SUBAREA TO MAINLINE PEAK FLOW<<<<<

=====

50 YEAR RAINFALL INTENSITY (INCH/HOUR) = 1.788
GRASS FAIR COVER RUNOFF COEFFICIENT = .4500
SOIL CLASSIFICATION IS "D"
S.C.S. CURVE NUMBER (AMC II) = 84
SUBAREA AREA (ACRES) = 16.40 SUBAREA RUNOFF (CFS) = 13.20
TOTAL AREA (ACRES) = 16.50 TOTAL RUNOFF (CFS) = 13.32
TC (MIN.) = 20.76

FLOW PROCESS FROM NODE 0.00 TO NODE 0.00 IS CODE = 13

>>>>CLEAR THE MAIN-STREAM MEMORY<<<<<

FLOW PROCESS FROM NODE 3600.00 TO NODE 3601.00 IS CODE = 21

>>>>RATIONAL METHOD INITIAL SUBAREA ANALYSIS<<<<<

=====

GRASS FAIR COVER RUNOFF COEFFICIENT = .4500
SOIL CLASSIFICATION IS "D"
S.C.S. CURVE NUMBER (AMC II) = 84
NATURAL WATERSHED NOMOGRAPH TIME OF CONCENTRATION (APPENDIX X-A)
WITH 10-MIN. ADDED = 10.83 (MIN.)
INITIAL SUBAREA FLOW-LENGTH (FEET) = 70.00
UPSTREAM ELEVATION (FEET) = 108.00
DOWNSTREAM ELEVATION (FEET) = 106.13
ELEVATION DIFFERENCE (FEET) = 1.87
NATURAL WATERSHED TIME OF CONCENTRATION = 10.83
50 YEAR RAINFALL INTENSITY (INCH/HOUR) = 2.721
SUBAREA RUNOFF (CFS) = 0.12
TOTAL AREA (ACRES) = 0.10 TOTAL RUNOFF (CFS) = 0.12

FLOW PROCESS FROM NODE 3601.00 TO NODE 3602.00 IS CODE = 51

>>>>COMPUTE TRAPEZOIDAL CHANNEL FLOW<<<<<
>>>>TRAVELTIME THRU SUBAREA (EXISTING ELEMENT)<<<<<

=====

CHANNEL LENGTH THRU SUBAREA (FEET) = 230.00
REPRESENTATIVE CHANNEL SLOPE = 0.0267
CHANNEL BASE (FEET) = 10.00 "Z" FACTOR = 50.000
MANNING'S FACTOR = 0.030 MAXIMUM DEPTH (FEET) = 2.00
CHANNEL FLOW THRU SUBAREA (CFS) = 0.12
FLOW VELOCITY (FEET/SEC.) = 0.56 FLOW DEPTH (FEET) = 0.02
TRAVEL TIME (MIN.) = 6.90 Tc (MIN.) = 17.73

LONGEST FLOWPATH FROM NODE 3600.00 TO NODE 3602.00 = 300.00 FEET.

FLOW PROCESS FROM NODE 3602.00 TO NODE 3603.00 IS CODE = 81

>>>>ADDITION OF SUBAREA TO MAINLINE PEAK FLOW<<<<<

=====

50 YEAR RAINFALL INTENSITY (INCH/HOUR) =	1.980
GRASS FAIR COVER RUNOFF COEFFICIENT =	.4500
SOIL CLASSIFICATION IS "D"	
S.C.S. CURVE NUMBER (AMC II) =	84
SUBAREA AREA (ACRES) =	12.10
SUBAREA RUNOFF (CFS) =	10.78
TOTAL AREA (ACRES) =	12.20
TOTAL RUNOFF (CFS) =	10.90
TC (MIN.) =	17.73

FLOW PROCESS FROM NODE 0.00 TO NODE 0.00 IS CODE = 13

>>>>CLEAR THE MAIN-STREAM MEMORY<<<<<

FLOW PROCESS FROM NODE 3700.00 TO NODE 3701.00 IS CODE = 21

>>>>RATIONAL METHOD INITIAL SUBAREA ANALYSIS<<<<<

=====

GRASS FAIR COVER RUNOFF COEFFICIENT =	.4500
SOIL CLASSIFICATION IS "D"	
S.C.S. CURVE NUMBER (AMC II) =	84
NATURAL WATERSHED NOMOGRAPH TIME OF CONCENTRATION (APPENDIX X-A) WITH 10-MIN. ADDED =	10.85 (MIN.)
INITIAL SUBAREA FLOW-LENGTH (FEET) =	70.00
UPSTREAM ELEVATION (FEET) =	120.00
DOWNSTREAM ELEVATION (FEET) =	118.25
ELEVATION DIFFERENCE (FEET) =	1.75
NATURAL WATERSHED TIME OF CONCENTRATION =	10.85
50 YEAR RAINFALL INTENSITY (INCH/HOUR) =	2.717
SUBAREA RUNOFF (CFS) =	0.12
TOTAL AREA (ACRES) =	0.10
TOTAL RUNOFF (CFS) =	0.12

FLOW PROCESS FROM NODE 3701.00 TO NODE 3702.00 IS CODE = 51

>>>>COMPUTE TRAPEZOIDAL CHANNEL FLOW<<<<<
>>>>TRAVELTIME THRU SUBAREA (EXISTING ELEMENT) <<<<<

=====

CHANNEL LENGTH THRU SUBAREA (FEET) =	730.00
REPRESENTATIVE CHANNEL SLOPE =	0.0250
CHANNEL BASE (FEET) =	10.00
"Z" FACTOR =	50.000
MANNING'S FACTOR =	0.030
MAXIMUM DEPTH (FEET) =	2.00
CHANNEL FLOW THRU SUBAREA (CFS) =	0.12
FLOW VELOCITY (FEET/SEC.) =	0.55
FLOW DEPTH (FEET) =	0.02
TRAVEL TIME (MIN.) =	21.92
Tc (MIN.) =	32.77
LONGEST FLOWPATH FROM NODE 3700.00 TO NODE 3702.00 =	800.00 FEET.

FLOW PROCESS FROM NODE 3702.00 TO NODE 3703.00 IS CODE = 81

```

-----
>>>>ADDITION OF SUBAREA TO MAINLINE PEAK FLOW<<<<
=====
50 YEAR RAINFALL INTENSITY (INCH/HOUR) = 1.332
GRASS FAIR COVER RUNOFF COEFFICIENT = .4500
SOIL CLASSIFICATION IS "D"
S.C.S. CURVE NUMBER (AMC II) = 84
SUBAREA AREA (ACRES) = 46.00 SUBAREA RUNOFF (CFS) = 27.57
TOTAL AREA (ACRES) = 46.10 TOTAL RUNOFF (CFS) = 27.69
TC (MIN.) = 32.77

*****
FLOW PROCESS FROM NODE 0.00 TO NODE 0.00 IS CODE = 13
-----
>>>>CLEAR THE MAIN-STREAM MEMORY<<<<
=====
*****
FLOW PROCESS FROM NODE 3800.00 TO NODE 3801.00 IS CODE = 21
-----
>>>>RATIONAL METHOD INITIAL SUBAREA ANALYSIS<<<<
=====
GRASS FAIR COVER RUNOFF COEFFICIENT = .4500
SOIL CLASSIFICATION IS "D"
S.C.S. CURVE NUMBER (AMC II) = 84
NATURAL WATERSHED NOMOGRAPH TIME OF CONCENTRATION (APPENDIX X-A)
WITH 10-MIN. ADDED = 10.85 (MIN.)
INITIAL SUBAREA FLOW-LENGTH (FEET) = 70.00
UPSTREAM ELEVATION (FEET) = 125.00
DOWNSTREAM ELEVATION (FEET) = 123.25
ELEVATION DIFFERENCE (FEET) = 1.75
NATURAL WATERSHED TIME OF CONCENTRATION = 10.85
50 YEAR RAINFALL INTENSITY (INCH/HOUR) = 2.717
SUBAREA RUNOFF (CFS) = 0.12
TOTAL AREA (ACRES) = 0.10 TOTAL RUNOFF (CFS) = 0.12

*****
FLOW PROCESS FROM NODE 3801.00 TO NODE 3802.00 IS CODE = 51
-----
>>>>COMPUTE TRAPEZOIDAL CHANNEL FLOW<<<<
>>>>TRAVELTIME THRU SUBAREA (EXISTING ELEMENT)<<<<
=====
CHANNEL LENGTH THRU SUBAREA (FEET) = 930.00
REPRESENTATIVE CHANNEL SLOPE = 0.0250
CHANNEL BASE (FEET) = 10.00 "Z" FACTOR = 50.000
MANNING'S FACTOR = 0.030 MAXIMUM DEPTH (FEET) = 2.00
CHANNEL FLOW THRU SUBAREA (CFS) = 0.12
FLOW VELOCITY (FEET/SEC.) = 0.55 FLOW DEPTH (FEET) = 0.02
TRAVEL TIME (MIN.) = 27.93 Tc (MIN.) = 38.78
LONGEST FLOWPATH FROM NODE 3800.00 TO NODE 3802.00 = 1000.00 FEET.

*****
FLOW PROCESS FROM NODE 3802.00 TO NODE 3803.00 IS CODE = 81
-----
>>>>ADDITION OF SUBAREA TO MAINLINE PEAK FLOW<<<<
=====
50 YEAR RAINFALL INTENSITY (INCH/HOUR) = 1.195

```

GRASS FAIR COVER RUNOFF COEFFICIENT = .4500
SOIL CLASSIFICATION IS "D"
S.C.S. CURVE NUMBER (AMC II) = 84
SUBAREA AREA(ACRES) = 51.30 SUBAREA RUNOFF(CFS) = 27.59
TOTAL AREA(ACRES) = 51.40 TOTAL RUNOFF(CFS) = 27.71
TC(MIN.) = 38.78

FLOW PROCESS FROM NODE 0.00 TO NODE 0.00 IS CODE = 13

>>>>CLEAR THE MAIN-STREAM MEMORY<<<<<

FLOW PROCESS FROM NODE 2100.00 TO NODE 2101.00 IS CODE = 21

>>>>RATIONAL METHOD INITIAL SUBAREA ANALYSIS<<<<<

=====

GRASS FAIR COVER RUNOFF COEFFICIENT = .4500
SOIL CLASSIFICATION IS "D"
S.C.S. CURVE NUMBER (AMC II) = 84
NATURAL WATERSHED NOMOGRAPH TIME OF CONCENTRATION (APPENDIX X-A)
WITH 10-MIN. ADDED = 10.85(MIN.)
INITIAL SUBAREA FLOW-LENGTH(FEET) = 70.00
UPSTREAM ELEVATION(FEET) = 128.00
DOWNSTREAM ELEVATION(FEET) = 126.22
ELEVATION DIFFERENCE(FEET) = 1.78
NATURAL WATERSHED TIME OF CONCENTRATION = 10.85
50 YEAR RAINFALL INTENSITY(INCH/HOUR) = 2.718
SUBAREA RUNOFF(CFS) = 0.12
TOTAL AREA(ACRES) = 0.10 TOTAL RUNOFF(CFS) = 0.12

FLOW PROCESS FROM NODE 2101.00 TO NODE 2102.00 IS CODE = 51

>>>>COMPUTE TRAPEZOIDAL CHANNEL FLOW<<<<<
>>>>TRAVELTIME THRU SUBAREA (EXISTING ELEMENT)<<<<<

=====

CHANNEL LENGTH THRU SUBAREA(FEET) = 1030.00
REPRESENTATIVE CHANNEL SLOPE = 0.0255
CHANNEL BASE(FEET) = 10.00 "Z" FACTOR = 50.000
MANNING'S FACTOR = 0.030 MAXIMUM DEPTH(FEET) = 2.00
CHANNEL FLOW THRU SUBAREA(CFS) = 0.12
FLOW VELOCITY(FEET/SEC.) = 0.56 FLOW DEPTH(FEET) = 0.02
TRAVEL TIME(MIN.) = 30.92 Tc(MIN.) = 41.77
LONGEST FLOWPATH FROM NODE 2100.00 TO NODE 2102.00 = 1100.00 FEET.

FLOW PROCESS FROM NODE 2102.00 TO NODE 2103.00 IS CODE = 81

>>>>ADDITION OF SUBAREA TO MAINLINE PEAK FLOW<<<<<

=====

50 YEAR RAINFALL INTENSITY(INCH/HOUR) = 1.139
GRASS FAIR COVER RUNOFF COEFFICIENT = .4500
SOIL CLASSIFICATION IS "D"
S.C.S. CURVE NUMBER (AMC II) = 84
SUBAREA AREA(ACRES) = 33.20 SUBAREA RUNOFF(CFS) = 17.02

TOTAL AREA(ACRES) = 33.30 TOTAL RUNOFF(CFS) = 17.14
TC(MIN.) = 41.77

FLOW PROCESS FROM NODE 0.00 TO NODE 0.00 IS CODE = 13

>>>>CLEAR THE MAIN-STREAM MEMORY<<<<<

FLOW PROCESS FROM NODE 2200.00 TO NODE 2201.00 IS CODE = 21

>>>>RATIONAL METHOD INITIAL SUBAREA ANALYSIS<<<<<

GRASS FAIR COVER RUNOFF COEFFICIENT = .4500
SOIL CLASSIFICATION IS "D"
S.C.S. CURVE NUMBER (AMC II) = 84
NATURAL WATERSHED NOMOGRAPH TIME OF CONCENTRATION (APPENDIX X-A)
WITH 10-MIN. ADDED = 10.85(MIN.)
INITIAL SUBAREA FLOW-LENGTH(FEET) = 70.00
UPSTREAM ELEVATION(FEET) = 163.00
DOWNSTREAM ELEVATION(FEET) = 161.24
ELEVATION DIFFERENCE(FEET) = 1.76
NATURAL WATERSHED TIME OF CONCENTRATION = 10.85
50 YEAR RAINFALL INTENSITY(INCH/HOUR) = 2.718
SUBAREA RUNOFF(CFS) = 0.12
TOTAL AREA(ACRES) = 0.10 TOTAL RUNOFF(CFS) = 0.12

FLOW PROCESS FROM NODE 2201.00 TO NODE 2202.00 IS CODE = 51

>>>>COMPUTE TRAPEZOIDAL CHANNEL FLOW<<<<<
>>>>TRAVELTIME THRU SUBAREA (EXISTING ELEMENT)<<<<<

CHANNEL LENGTH THRU SUBAREA(FEET) = 2430.00
REPRESENTATIVE CHANNEL SLOPE = 0.0252
CHANNEL BASE(FEET) = 10.00 "Z" FACTOR = 50.000
MANNING'S FACTOR = 0.030 MAXIMUM DEPTH(FEET) = 2.00
CHANNEL FLOW THRU SUBAREA(CFS) = 0.12
FLOW VELOCITY(FEET/SEC.) = 0.56 FLOW DEPTH(FEET) = 0.02
TRAVEL TIME(MIN.) = 72.97 Tc(MIN.) = 83.82
LONGEST FLOWPATH FROM NODE 2200.00 TO NODE 2202.00 = 2500.00 FEET.

FLOW PROCESS FROM NODE 2202.00 TO NODE 2203.00 IS CODE = 81

>>>>ADDITION OF SUBAREA TO MAINLINE PEAK FLOW<<<<<

50 YEAR RAINFALL INTENSITY(INCH/HOUR) = 0.727
GRASS FAIR COVER RUNOFF COEFFICIENT = .4500
SOIL CLASSIFICATION IS "D"
S.C.S. CURVE NUMBER (AMC II) = 84
SUBAREA AREA(ACRES) = 126.10 SUBAREA RUNOFF(CFS) = 41.25
TOTAL AREA(ACRES) = 126.20 TOTAL RUNOFF(CFS) = 41.37
TC(MIN.) = 83.82

```

FLOW PROCESS FROM NODE      0.00 TO NODE      0.00 IS CODE = 13
-----
>>>>CLEAR THE MAIN-STREAM MEMORY<<<<<
=====
*****
FLOW PROCESS FROM NODE      2180.00 TO NODE      2181.00 IS CODE = 21
-----
>>>>RATIONAL METHOD INITIAL SUBAREA ANALYSIS<<<<<
=====
GRASS FAIR COVER RUNOFF COEFFICIENT = .4500
SOIL CLASSIFICATION IS "D"
S.C.S. CURVE NUMBER (AMC II) = 84
NATURAL WATERSHED NOMOGRAPH TIME OF CONCENTRATION (APPENDIX X-A)
WITH 10-MIN. ADDED = 10.85 (MIN.)
INITIAL SUBAREA FLOW-LENGTH (FEET) = 70.00
UPSTREAM ELEVATION (FEET) = 130.00
DOWNSTREAM ELEVATION (FEET) = 128.25
ELEVATION DIFFERENCE (FEET) = 1.75
NATURAL WATERSHED TIME OF CONCENTRATION = 10.85
50 YEAR RAINFALL INTENSITY (INCH/HOUR) = 2.717
SUBAREA RUNOFF (CFS) = 0.12
TOTAL AREA (ACRES) = 0.10 TOTAL RUNOFF (CFS) = 0.12
-----
*****
FLOW PROCESS FROM NODE      2181.00 TO NODE      2182.00 IS CODE = 51
-----
>>>>COMPUTE TRAPEZOIDAL CHANNEL FLOW<<<<<
>>>>TRAVEL TIME THRU SUBAREA (EXISTING ELEMENT)<<<<<
=====
CHANNEL LENGTH THRU SUBAREA (FEET) = 1130.00
REPRESENTATIVE CHANNEL SLOPE = 0.0250
CHANNEL BASE (FEET) = 10.00 "Z" FACTOR = 50.000
MANNING'S FACTOR = 0.030 MAXIMUM DEPTH (FEET) = 2.00
CHANNEL FLOW THRU SUBAREA (CFS) = 0.12
FLOW VELOCITY (FEET/SEC.) = 0.55 FLOW DEPTH (FEET) = 0.02
TRAVEL TIME (MIN.) = 33.94 Tc (MIN.) = 44.79
LONGEST FLOWPATH FROM NODE 2180.00 TO NODE 2182.00 = 1200.00 FEET.
-----
*****
FLOW PROCESS FROM NODE      2182.00 TO NODE      2183.00 IS CODE = 81
-----
>>>>ADDITION OF SUBAREA TO MAINLINE PEAK FLOW<<<<<
=====
50 YEAR RAINFALL INTENSITY (INCH/HOUR) = 1.089
GRASS FAIR COVER RUNOFF COEFFICIENT = .4500
SOIL CLASSIFICATION IS "D"
S.C.S. CURVE NUMBER (AMC II) = 84
SUBAREA AREA (ACRES) = 97.00 SUBAREA RUNOFF (CFS) = 47.54
TOTAL AREA (ACRES) = 97.10 TOTAL RUNOFF (CFS) = 47.66
TC (MIN.) = 44.79
-----
*****
FLOW PROCESS FROM NODE      0.00 TO NODE      0.00 IS CODE = 13
-----
>>>>CLEAR THE MAIN-STREAM MEMORY<<<<<
=====

```

S.C.S. CURVE NUMBER (AMC II) = 84
NATURAL WATERSHED NOMOGRAPH TIME OF CONCENTRATION (APPENDIX X-A)
WITH 10-MIN. ADDED = 10.86 (MIN.)
INITIAL SUBAREA FLOW-LENGTH (FEET) = 70.00
UPSTREAM ELEVATION (FEET) = 122.00
DOWNSTREAM ELEVATION (FEET) = 120.29
ELEVATION DIFFERENCE (FEET) = 1.71
NATURAL WATERSHED TIME OF CONCENTRATION = 10.86
50 YEAR RAINFALL INTENSITY (INCH/HOUR) = 2.716
SUBAREA RUNOFF (CFS) = 0.12
TOTAL AREA (ACRES) = 0.10 TOTAL RUNOFF (CFS) = 0.12

FLOW PROCESS FROM NODE 2401.00 TO NODE 2402.00 IS CODE = 51

>>>>COMPUTE TRAPEZOIDAL CHANNEL FLOW<<<<<
>>>>TRAVELTIME THRU SUBAREA (EXISTING ELEMENT)<<<<<

=====

CHANNEL LENGTH THRU SUBAREA (FEET)	=	830.00
REPRESENTATIVE CHANNEL SLOPE	=	0.0244
CHANNEL BASE (FEET)	=	10.00 "Z" FACTOR = 50.000
MANNING'S FACTOR	=	0.030 MAXIMUM DEPTH (FEET) = 2.00
CHANNEL FLOW THRU SUBAREA (CFS)	=	0.12
FLOW VELOCITY (FEET/SEC.)	=	0.55 FLOW DEPTH (FEET) = 0.02
TRAVEL TIME (MIN.)	=	24.94 Tc (MIN.) = 35.80
LONGEST FLOWPATH FROM NODE	2400.00 TO NODE	2402.00 = 900.00 FEET.

FLOW PROCESS FROM NODE 2402.00 TO NODE 2403.00 IS CODE = 81

>>>>ADDITION OF SUBAREA TO MAINLINE PEAK FLOW<<<<<

=====

50 YEAR RAINFALL INTENSITY (INCH/HOUR)	=	1.258
GRASS FAIR COVER RUNOFF COEFFICIENT	=	.4500
SOIL CLASSIFICATION IS	"D"	
S.C.S. CURVE NUMBER (AMC II)	=	84
SUBAREA AREA (ACRES)	=	67.70 SUBAREA RUNOFF (CFS) = 38.34
TOTAL AREA (ACRES)	=	67.80 TOTAL RUNOFF (CFS) = 38.46
TC (MIN.)	=	35.80

FLOW PROCESS FROM NODE 0.00 TO NODE 0.00 IS CODE = 13

>>>>CLEAR THE MAIN-STREAM MEMORY<<<<<

FLOW PROCESS FROM NODE 2500.00 TO NODE 2501.00 IS CODE = 21

>>>>RATIONAL METHOD INITIAL SUBAREA ANALYSIS<<<<<

=====

GRASS FAIR COVER RUNOFF COEFFICIENT	=	.4500
SOIL CLASSIFICATION IS	"D"	
S.C.S. CURVE NUMBER (AMC II)	=	84
NATURAL WATERSHED NOMOGRAPH TIME OF CONCENTRATION (APPENDIX X-A)		
WITH 10-MIN. ADDED	=	10.85 (MIN.)
INITIAL SUBAREA FLOW-LENGTH (FEET)	=	70.00

UPSTREAM ELEVATION (FEET) = 130.00
DOWNSTREAM ELEVATION (FEET) = 128.25
ELEVATION DIFFERENCE (FEET) = 1.75
NATURAL WATERSHED TIME OF CONCENTRATION = 10.85
50 YEAR RAINFALL INTENSITY (INCH/HOUR) = 2.717
SUBAREA RUNOFF (CFS) = 0.12
TOTAL AREA (ACRES) = 0.10 TOTAL RUNOFF (CFS) = 0.12

FLOW PROCESS FROM NODE 2501.00 TO NODE 2502.00 IS CODE = 51

>>>> COMPUTE TRAPEZOIDAL CHANNEL FLOW<<<<<
>>>> TRAVEL TIME THRU SUBAREA (EXISTING ELEMENT) <<<<<

=====

CHANNEL LENGTH THRU SUBAREA (FEET) = 1130.00
REPRESENTATIVE CHANNEL SLOPE = 0.0250
CHANNEL BASE (FEET) = 10.00 "Z" FACTOR = 50.000
MANNING'S FACTOR = 0.030 MAXIMUM DEPTH (FEET) = 2.00
CHANNEL FLOW THRU SUBAREA (CFS) = 0.12
FLOW VELOCITY (FEET/SEC.) = 0.55 FLOW DEPTH (FEET) = 0.02
TRAVEL TIME (MIN.) = 33.94 Tc (MIN.) = 44.79
LONGEST FLOWPATH FROM NODE 2500.00 TO NODE 2502.00 = 1200.00 FEET.

FLOW PROCESS FROM NODE 2502.00 TO NODE 2503.00 IS CODE = 81

>>>> ADDITION OF SUBAREA TO MAINLINE PEAK FLOW<<<<<

=====

50 YEAR RAINFALL INTENSITY (INCH/HOUR) = 1.089
GRASS FAIR COVER RUNOFF COEFFICIENT = .4500
SOIL CLASSIFICATION IS "D"
S.C.S. CURVE NUMBER (AMC II) = 84
SUBAREA AREA (ACRES) = 40.70 SUBAREA RUNOFF (CFS) = 19.95
TOTAL AREA (ACRES) = 40.80 TOTAL RUNOFF (CFS) = 20.07
TC (MIN.) = 44.79

FLOW PROCESS FROM NODE 0.00 TO NODE 0.00 IS CODE = 13

>>>> CLEAR THE MAIN-STREAM MEMORY<<<<<

FLOW PROCESS FROM NODE 2600.00 TO NODE 2601.00 IS CODE = 21

>>>> RATIONAL METHOD INITIAL SUBAREA ANALYSIS<<<<<

=====

GRASS FAIR COVER RUNOFF COEFFICIENT = .4500
SOIL CLASSIFICATION IS "D"
S.C.S. CURVE NUMBER (AMC II) = 84
NATURAL WATERSHED NOMOGRAPH TIME OF CONCENTRATION (APPENDIX X-A)
WITH 10-MIN. ADDED = 10.85 (MIN.)
INITIAL SUBAREA FLOW-LENGTH (FEET) = 70.00
UPSTREAM ELEVATION (FEET) = 130.00
DOWNSTREAM ELEVATION (FEET) = 128.25
ELEVATION DIFFERENCE (FEET) = 1.75
NATURAL WATERSHED TIME OF CONCENTRATION = 10.85

50 YEAR RAINFALL INTENSITY(INCH/HOUR) = 2.717
SUBAREA RUNOFF(CFS) = 0.12
TOTAL AREA(ACRES) = 0.10 TOTAL RUNOFF(CFS) = 0.12

FLOW PROCESS FROM NODE 2601.00 TO NODE 2602.00 IS CODE = 51

>>>>COMPUTE TRAPEZOIDAL CHANNEL FLOW<<<<<
>>>>TRAVELTIME THRU SUBAREA (EXISTING ELEMENT)<<<<<

=====
CHANNEL LENGTH THRU SUBAREA(FEET) = 1130.00
REPRESENTATIVE CHANNEL SLOPE = 0.0250
CHANNEL BASE(FEET) = 10.00 "Z" FACTOR = 50.000
MANNING'S FACTOR = 0.030 MAXIMUM DEPTH(FEET) = 2.00
CHANNEL FLOW THRU SUBAREA(CFS) = 0.12
FLOW VELOCITY(FEET/SEC.) = 0.55 FLOW DEPTH(FEET) = 0.02
TRAVEL TIME(MIN.) = 33.94 Tc(MIN.) = 44.79
LONGEST FLOWPATH FROM NODE 2600.00 TO NODE 2602.00 = 1200.00 FEET.

FLOW PROCESS FROM NODE 2602.00 TO NODE 2603.00 IS CODE = 81

>>>>ADDITION OF SUBAREA TO MAINLINE PEAK FLOW<<<<<

=====
50 YEAR RAINFALL INTENSITY(INCH/HOUR) = 1.089
GRASS FAIR COVER RUNOFF COEFFICIENT = .4500
SOIL CLASSIFICATION IS "D"
S.C.S. CURVE NUMBER (AMC II) = 84
SUBAREA AREA(ACRES) = 34.70 SUBAREA RUNOFF(CFS) = 17.00
TOTAL AREA(ACRES) = 34.80 TOTAL RUNOFF(CFS) = 17.13
TC(MIN.) = 44.79

FLOW PROCESS FROM NODE 0.00 TO NODE 0.00 IS CODE = 13

>>>>CLEAR THE MAIN-STREAM MEMORY<<<<<

FLOW PROCESS FROM NODE 2700.00 TO NODE 2701.00 IS CODE = 21

>>>>RATIONAL METHOD INITIAL SUBAREA ANALYSIS<<<<<

=====
GRASS FAIR COVER RUNOFF COEFFICIENT = .4500
SOIL CLASSIFICATION IS "D"
S.C.S. CURVE NUMBER (AMC II) = 84
INITIAL SUBAREA FLOW-LENGTH(FEET) = 70.00
UPSTREAM ELEVATION(FEET) = 105.00
DOWNSTREAM ELEVATION(FEET) = 103.25
ELEVATION DIFFERENCE(FEET) = 1.75
URBAN SUBAREA OVERLAND TIME OF FLOW(MIN.) = 7.213
50 YEAR RAINFALL INTENSITY(INCH/HOUR) = 3.536
SUBAREA RUNOFF(CFS) = 0.16
TOTAL AREA(ACRES) = 0.10 TOTAL RUNOFF(CFS) = 0.16

FLOW PROCESS FROM NODE 2701.00 TO NODE 2702.00 IS CODE = 51

```

-----
>>>>COMPUTE TRAPEZOIDAL CHANNEL FLOW<<<<<
>>>>TRAVELTIME THRU SUBAREA (EXISTING ELEMENT)<<<<<
=====
CHANNEL LENGTH THRU SUBAREA(FEET) = 130.00
REPRESENTATIVE CHANNEL SLOPE = 0.0250
CHANNEL BASE(FEET) = 10.00 "Z" FACTOR = 50.000
MANNING'S FACTOR = 0.030 MAXIMUM DEPTH(FEET) = 2.00
CHANNEL FLOW THRU SUBAREA(CFS) = 0.16
FLOW VELOCITY(FEET/SEC.) = 0.55 FLOW DEPTH(FEET) = 0.03
TRAVEL TIME(MIN.) = 3.96 Tc(MIN.) = 11.17
LONGEST FLOWPATH FROM NODE 2700.00 TO NODE 2702.00 = 200.00 FEET.

*****
FLOW PROCESS FROM NODE 2702.00 TO NODE 2703.00 IS CODE = 81
-----
>>>>ADDITION OF SUBAREA TO MAINLINE PEAK FLOW<<<<<
=====
50 YEAR RAINFALL INTENSITY(INCH/HOUR) = 2.667
GRASS FAIR COVER RUNOFF COEFFICIENT = .4500
SOIL CLASSIFICATION IS "D"
S.C.S. CURVE NUMBER (AMC II) = 84
SUBAREA AREA(ACRES) = 14.80 SUBAREA RUNOFF(CFS) = 17.76
TOTAL AREA(ACRES) = 14.90 TOTAL RUNOFF(CFS) = 17.92
TC(MIN.) = 11.17

*****
FLOW PROCESS FROM NODE 0.00 TO NODE 0.00 IS CODE = 13
-----
>>>>CLEAR THE MAIN-STREAM MEMORY<<<<<
=====
*****
FLOW PROCESS FROM NODE 2800.00 TO NODE 2801.00 IS CODE = 21
-----
>>>>RATIONAL METHOD INITIAL SUBAREA ANALYSIS<<<<<
=====
GRASS FAIR COVER RUNOFF COEFFICIENT = .4500
SOIL CLASSIFICATION IS "D"
S.C.S. CURVE NUMBER (AMC II) = 84
NATURAL WATERSHED NOMOGRAPH TIME OF CONCENTRATION (APPENDIX X-A)
WITH 10-MIN. ADDED = 10.18(MIN.)
INITIAL SUBAREA FLOW-LENGTH(FEET) = 70.00
UPSTREAM ELEVATION(FEET) = 128.00
DOWNSTREAM ELEVATION(FEET) = 26.22
ELEVATION DIFFERENCE(FEET) = 101.78
NATURAL WATERSHED TIME OF CONCENTRATION = 10.18
50 YEAR RAINFALL INTENSITY(INCH/HOUR) = 2.832
SUBAREA RUNOFF(CFS) = 0.13
TOTAL AREA(ACRES) = 0.10 TOTAL RUNOFF(CFS) = 0.13

*****
FLOW PROCESS FROM NODE 2801.00 TO NODE 2802.00 IS CODE = 51
-----
>>>>COMPUTE TRAPEZOIDAL CHANNEL FLOW<<<<<
>>>>TRAVELTIME THRU SUBAREA (EXISTING ELEMENT)<<<<<
=====

```

CHANNEL LENGTH THRU SUBAREA (FEET) = 1030.00
REPRESENTATIVE CHANNEL SLOPE = 0.0250
CHANNEL BASE (FEET) = 10.00 "Z" FACTOR = 50.000
MANNING'S FACTOR = 0.030 MAXIMUM DEPTH (FEET) = 2.00
CHANNEL FLOW THRU SUBAREA (CFS) = 0.13
FLOW VELOCITY (FEET/SEC.) = 0.58 FLOW DEPTH (FEET) = 0.02
TRAVEL TIME (MIN.) = 29.68 Tc (MIN.) = 39.86
LONGEST FLOWPATH FROM NODE 2800.00 TO NODE 2802.00 = 1100.00 FEET.

FLOW PROCESS FROM NODE 2802.00 TO NODE 2803.00 IS CODE = 81

>>>> ADDITION OF SUBAREA TO MAINLINE PEAK FLOW <<<<<

=====

50 YEAR RAINFALL INTENSITY (INCH/HOUR) = 1.174
GRASS FAIR COVER RUNOFF COEFFICIENT = .4500
SOIL CLASSIFICATION IS "D"
S.C.S. CURVE NUMBER (AMC II) = 84
SUBAREA AREA (ACRES) = 81.20 SUBAREA RUNOFF (CFS) = 42.90
TOTAL AREA (ACRES) = 81.30 TOTAL RUNOFF (CFS) = 43.03
TC (MIN.) = 39.86

FLOW PROCESS FROM NODE 0.00 TO NODE 0.00 IS CODE = 13

>>>> CLEAR THE MAIN-STREAM MEMORY <<<<<

FLOW PROCESS FROM NODE 2900.00 TO NODE 2901.00 IS CODE = 21

>>>> RATIONAL METHOD INITIAL SUBAREA ANALYSIS <<<<<

=====

GRASS FAIR COVER RUNOFF COEFFICIENT = .4500
SOIL CLASSIFICATION IS "D"
S.C.S. CURVE NUMBER (AMC II) = 84
NATURAL WATERSHED NOMOGRAPH TIME OF CONCENTRATION (APPENDIX X-A)
WITH 10-MIN. ADDED = 10.84 (MIN.)
INITIAL SUBAREA FLOW-LENGTH (FEET) = 70.00
UPSTREAM ELEVATION (FEET) = 118.00
DOWNSTREAM ELEVATION (FEET) = 116.20
ELEVATION DIFFERENCE (FEET) = 1.80
NATURAL WATERSHED TIME OF CONCENTRATION = 10.84
50 YEAR RAINFALL INTENSITY (INCH/HOUR) = 2.719
SUBAREA RUNOFF (CFS) = 0.12
TOTAL AREA (ACRES) = 0.10 TOTAL RUNOFF (CFS) = 0.12

FLOW PROCESS FROM NODE 2901.00 TO NODE 2902.00 IS CODE = 51

>>>> COMPUTE TRAPEZOIDAL CHANNEL FLOW <<<<<
>>>> TRAVELTIME THRU SUBAREA (EXISTING ELEMENT) <<<<<

=====

CHANNEL LENGTH THRU SUBAREA (FEET) = 630.00
REPRESENTATIVE CHANNEL SLOPE = 0.0250
CHANNEL BASE (FEET) = 10.00 "Z" FACTOR = 50.000
MANNING'S FACTOR = 0.030 MAXIMUM DEPTH (FEET) = 2.00

CHANNEL FLOW THRU SUBAREA(CFS) = 0.12
FLOW VELOCITY(FEET/SEC.) = 0.56 FLOW DEPTH(FEET) = 0.02
TRAVEL TIME(MIN.) = 18.91 Tc(MIN.) = 29.75
LONGEST FLOWPATH FROM NODE 2900.00 TO NODE 2902.00 = 700.00 FEET.

FLOW PROCESS FROM NODE 2902.00 TO NODE 2903.00 IS CODE = 81

< >>>>ADDITION OF SUBAREA TO MAINLINE PEAK FLOW<<<<<

=====

50 YEAR RAINFALL INTENSITY(INCH/HOUR) = 1.418
GRASS FAIR COVER RUNOFF COEFFICIENT = .4500
SOIL CLASSIFICATION IS "D"
S.C.S. CURVE NUMBER (AMC II) = 84
SUBAREA AREA(ACRES) = 36.80 SUBAREA RUNOFF(CFS) = 23.48
TOTAL AREA(ACRES) = 36.90 TOTAL RUNOFF(CFS) = 23.60
TC(MIN.) = 29.75

FLOW PROCESS FROM NODE 0.00 TO NODE 0.00 IS CODE = 13

< >>>>CLEAR THE MAIN-STREAM MEMORY<<<<<

FLOW PROCESS FROM NODE 2910.00 TO NODE 2911.00 IS CODE = 21

< >>>>RATIONAL METHOD INITIAL SUBAREA ANALYSIS<<<<<

=====

GRASS FAIR COVER RUNOFF COEFFICIENT = .4500
SOIL CLASSIFICATION IS "D"
S.C.S. CURVE NUMBER (AMC II) = 84
NATURAL WATERSHED NOMOGRAPH TIME OF CONCENTRATION (APPENDIX X-A)
WITH 10-MIN. ADDED = 10.85(MIN.)
INITIAL SUBAREA FLOW-LENGTH(FEET) = 70.00
UPSTREAM ELEVATION(FEET) = 108.00
DOWNSTREAM ELEVATION(FEET) = 106.25
ELEVATION DIFFERENCE(FEET) = 1.75
NATURAL WATERSHED TIME OF CONCENTRATION = 10.85
50 YEAR RAINFALL INTENSITY(INCH/HOUR) = 2.717
SUBAREA RUNOFF(CFS) = 0.12
TOTAL AREA(ACRES) = 0.10 TOTAL RUNOFF(CFS) = 0.12

FLOW PROCESS FROM NODE 2911.00 TO NODE 2912.00 IS CODE = 51

< >>>>COMPUTE TRAPEZOIDAL CHANNEL FLOW<<<<<

< >>>>TRAVELTIME THRU SUBAREA (EXISTING ELEMENT)<<<<<

=====

CHANNEL LENGTH THRU SUBAREA(FEET) = 230.00
REPRESENTATIVE CHANNEL SLOPE = 0.0250
CHANNEL BASE(FEET) = 10.00 "Z" FACTOR = 50.000
MANNING'S FACTOR = 0.030 MAXIMUM DEPTH(FEET) = 2.00
CHANNEL FLOW THRU SUBAREA(CFS) = 0.12
FLOW VELOCITY(FEET/SEC.) = 0.55 FLOW DEPTH(FEET) = 0.02
TRAVEL TIME(MIN.) = 6.91 Tc(MIN.) = 17.76
LONGEST FLOWPATH FROM NODE 2910.00 TO NODE 2912.00 = 300.00 FEET.

FLOW PROCESS FROM NODE 2912.00 TO NODE 2913.00 IS CODE = 81

>>>>ADDITION OF SUBAREA TO MAINLINE PEAK FLOW<<<<<

=====

50 YEAR RAINFALL INTENSITY(INCH/HOUR)	=	1.978
GRASS FAIR COVER RUNOFF COEFFICIENT	=	.4500
SOIL CLASSIFICATION IS "D"		
S.C.S. CURVE NUMBER (AMC II)	=	84
SUBAREA AREA(ACRES)	=	12.80
SUBAREA RUNOFF(CFS)	=	11.39
TOTAL AREA(ACRES)	=	12.90
TOTAL RUNOFF(CFS)	=	11.51
TC(MIN.)	=	17.76

FLOW PROCESS FROM NODE 0.00 TO NODE 0.00 IS CODE = 13

>>>>CLEAR THE MAIN-STREAM MEMORY<<<<<

FLOW PROCESS FROM NODE 2100.00 TO NODE 2101.00 IS CODE = 21

>>>>RATIONAL METHOD INITIAL SUBAREA ANALYSIS<<<<<

=====

GRASS FAIR COVER RUNOFF COEFFICIENT	=	.4500
SOIL CLASSIFICATION IS "D"		
S.C.S. CURVE NUMBER (AMC II)	=	84
NATURAL WATERSHED NOMOGRAPH TIME OF CONCENTRATION (APPENDIX X-A)		
WITH 10-MIN. ADDED	=	10.85(MIN.)
INITIAL SUBAREA FLOW-LENGTH(FEET)	=	70.00
UPSTREAM ELEVATION(FEET)	=	160.00
DOWNSTREAM ELEVATION(FEET)	=	158.25
ELEVATION DIFFERENCE(FEET)	=	1.75
NATURAL WATERSHED TIME OF CONCENTRATION	=	10.85
50 YEAR RAINFALL INTENSITY(INCH/HOUR)	=	2.717
SUBAREA RUNOFF(CFS)	=	0.12
TOTAL AREA(ACRES)	=	0.10
TOTAL RUNOFF(CFS)	=	0.12

FLOW PROCESS FROM NODE 2101.00 TO NODE 2102.00 IS CODE = 51

>>>>COMPUTE TRAPEZOIDAL CHANNEL FLOW<<<<<
>>>>TRAVELTIME THRU SUBAREA (EXISTING ELEMENT)<<<<<

=====

CHANNEL LENGTH THRU SUBAREA(FEET)	=	2330.00
REPRESENTATIVE CHANNEL SLOPE	=	0.0250
CHANNEL BASE(FEET)	=	10.00
"Z" FACTOR	=	50.000
MANNING'S FACTOR	=	0.030
MAXIMUM DEPTH(FEET)	=	2.00
CHANNEL FLOW THRU SUBAREA(CFS)	=	0.12
FLOW VELOCITY(FEET/SEC.)	=	0.55
FLOW DEPTH(FEET)	=	0.02
TRAVEL TIME(MIN.)	=	69.97
Tc(MIN.)	=	80.82
LONGEST FLOWPATH FROM NODE 2100.00 TO NODE 2102.00	=	2400.00 FEET.

FLOW PROCESS FROM NODE 2102.00 TO NODE 2103.00 IS CODE = 81

>>>>ADDITION OF SUBAREA TO MAINLINE PEAK FLOW<<<<<

=====

50 YEAR RAINFALL INTENSITY(INCH/HOUR) = 0.744
GRASS FAIR COVER RUNOFF COEFFICIENT = .4500
SOIL CLASSIFICATION IS "D"
S.C.S. CURVE NUMBER (AMC II) = 84
SUBAREA AREA(ACRES) = 128.30 SUBAREA RUNOFF(CFS) = 42.96
TOTAL AREA(ACRES) = 128.40 TOTAL RUNOFF(CFS) = 43.09
TC(MIN.) = 80.82

FLOW PROCESS FROM NODE 0.00 TO NODE 0.00 IS CODE = 13

>>>>CLEAR THE MAIN-STREAM MEMORY<<<<<

FLOW PROCESS FROM NODE 2110.00 TO NODE 2111.00 IS CODE = 21

>>>>RATIONAL METHOD INITIAL SUBAREA ANALYSIS<<<<<

=====

GRASS FAIR COVER RUNOFF COEFFICIENT = .4500
SOIL CLASSIFICATION IS "D"
S.C.S. CURVE NUMBER (AMC II) = 84
NATURAL WATERSHED NOMOGRAPH TIME OF CONCENTRATION (APPENDIX X-A)
WITH 10-MIN. ADDED = 10.85(MIN.)
INITIAL SUBAREA FLOW-LENGTH(FEET) = 70.00
UPSTREAM ELEVATION(FEET) = 143.00
DOWNSTREAM ELEVATION(FEET) = 141.25
ELEVATION DIFFERENCE(FEET) = 1.75
NATURAL WATERSHED TIME OF CONCENTRATION = 10.85
50 YEAR RAINFALL INTENSITY(INCH/HOUR) = 2.717
SUBAREA RUNOFF(CFS) = 0.12
TOTAL AREA(ACRES) = 0.10 TOTAL RUNOFF(CFS) = 0.12

FLOW PROCESS FROM NODE 2111.00 TO NODE 2112.00 IS CODE = 51

>>>>COMPUTE TRAPEZOIDAL CHANNEL FLOW<<<<<
>>>>TRAVELTIME THRU SUBAREA (EXISTING ELEMENT)<<<<<

=====

CHANNEL LENGTH THRU SUBAREA(FEET) = 1630.00
REPRESENTATIVE CHANNEL SLOPE = 0.0250
CHANNEL BASE(FEET) = 10.00 "Z" FACTOR = 50.000
MANNING'S FACTOR = 0.030 MAXIMUM DEPTH(FEET) = 2.00
CHANNEL FLOW THRU SUBAREA(CFS) = 0.12
FLOW VELOCITY(FEET/SEC.) = 0.55 FLOW DEPTH(FEET) = 0.02
TRAVEL TIME(MIN.) = 48.95 Tc(MIN.) = 59.80
LONGEST FLOWPATH FROM NODE 2110.00 TO NODE 2112.00 = 1700.00 FEET.

FLOW PROCESS FROM NODE 2112.00 TO NODE 2113.00 IS CODE = 81

>>>>ADDITION OF SUBAREA TO MAINLINE PEAK FLOW<<<<<

=====

50 YEAR RAINFALL INTENSITY(INCH/HOUR) = 0.904
GRASS FAIR COVER RUNOFF COEFFICIENT = .4500

SOIL CLASSIFICATION IS "D"
S.C.S. CURVE NUMBER (AMC II) = 84
SUBAREA AREA (ACRES) = 275.50 SUBAREA RUNOFF (CFS) = 112.04
TOTAL AREA (ACRES) = 275.60 TOTAL RUNOFF (CFS) = 112.16
TC (MIN.) = 59.80

FLOW PROCESS FROM NODE 0.00 TO NODE 0.00 IS CODE = 13

>>>>CLEAR THE MAIN-STREAM MEMORY<<<<<

FLOW PROCESS FROM NODE 2120.00 TO NODE 2121.00 IS CODE = 21

>>>>RATIONAL METHOD INITIAL SUBAREA ANALYSIS<<<<<

=====

GRASS FAIR COVER RUNOFF COEFFICIENT = .4500
SOIL CLASSIFICATION IS "D"
S.C.S. CURVE NUMBER (AMC II) = 84
NATURAL WATERSHED NOMOGRAPH TIME OF CONCENTRATION (APPENDIX X-A)
WITH 10-MIN. ADDED = 10.85 (MIN.)
INITIAL SUBAREA FLOW-LENGTH (FEET) = 70.00
UPSTREAM ELEVATION (FEET) = 113.00
DOWNSTREAM ELEVATION (FEET) = 111.25
ELEVATION DIFFERENCE (FEET) = 1.75
NATURAL WATERSHED TIME OF CONCENTRATION = 10.85
50 YEAR RAINFALL INTENSITY (INCH/HOUR) = 2.717
SUBAREA RUNOFF (CFS) = 0.12
TOTAL AREA (ACRES) = 0.10 TOTAL RUNOFF (CFS) = 0.12

FLOW PROCESS FROM NODE 2121.00 TO NODE 2122.00 IS CODE = 51

>>>>COMPUTE TRAPEZOIDAL CHANNEL FLOW<<<<<
>>>>TRAVELTIME THRU SUBAREA (EXISTING ELEMENT)<<<<<

=====

CHANNEL LENGTH THRU SUBAREA (FEET) = 430.00
REPRESENTATIVE CHANNEL SLOPE = 0.0250
CHANNEL BASE (FEET) = 10.00 "Z" FACTOR = 50.000
MANNING'S FACTOR = 0.030 MAXIMUM DEPTH (FEET) = 2.00
CHANNEL FLOW THRU SUBAREA (CFS) = 0.12
FLOW VELOCITY (FEET/SEC.) = 0.55 FLOW DEPTH (FEET) = 0.02
TRAVEL TIME (MIN.) = 12.91 Tc (MIN.) = 23.76
LONGEST FLOWPATH FROM NODE 2120.00 TO NODE 2122.00 = 500.00 FEET.

FLOW PROCESS FROM NODE 2122.00 TO NODE 2123.00 IS CODE = 81

>>>>ADDITION OF SUBAREA TO MAINLINE PEAK FLOW<<<<<

=====

50 YEAR RAINFALL INTENSITY (INCH/HOUR) = 1.639
GRASS FAIR COVER RUNOFF COEFFICIENT = .4500
SOIL CLASSIFICATION IS "D"
S.C.S. CURVE NUMBER (AMC II) = 84
SUBAREA AREA (ACRES) = 23.50 SUBAREA RUNOFF (CFS) = 17.33
TOTAL AREA (ACRES) = 23.60 TOTAL RUNOFF (CFS) = 17.45

TC(MIN.) = 23.76

FLOW PROCESS FROM NODE 0.00 TO NODE 0.00 IS CODE = 13

>>>>CLEAR THE MAIN-STREAM MEMORY<<<<<

FLOW PROCESS FROM NODE 2130.00 TO NODE 2131.00 IS CODE = 21

>>>>RATIONAL METHOD INITIAL SUBAREA ANALYSIS<<<<<

=====

GRASS FAIR COVER RUNOFF COEFFICIENT = .4500
SOIL CLASSIFICATION IS "D"
S.C.S. CURVE NUMBER (AMC II) = 84
NATURAL WATERSHED NOMOGRAPH TIME OF CONCENTRATION (APPENDIX X-A)
WITH 10-MIN. ADDED = 10.85 (MIN.)
INITIAL SUBAREA FLOW-LENGTH (FEET) = 70.00
UPSTREAM ELEVATION (FEET) = 115.00
DOWNSTREAM ELEVATION (FEET) = 113.25
ELEVATION DIFFERENCE (FEET) = 1.75
NATURAL WATERSHED TIME OF CONCENTRATION = 10.85
50 YEAR RAINFALL INTENSITY (INCH/HOUR) = 2.717
SUBAREA RUNOFF (CFS) = 0.12
TOTAL AREA (ACRES) = 0.10 TOTAL RUNOFF (CFS) = 0.12

FLOW PROCESS FROM NODE 2131.00 TO NODE 2132.00 IS CODE = 51

>>>>COMPUTE TRAPEZOIDAL CHANNEL FLOW<<<<<
>>>>TRAVELTIME THRU SUBAREA (EXISTING ELEMENT) <<<<<

=====

CHANNEL LENGTH THRU SUBAREA (FEET) = 530.00
REPRESENTATIVE CHANNEL SLOPE = 0.0250
CHANNEL BASE (FEET) = 10.00 "Z" FACTOR = 50.000
MANNING'S FACTOR = 0.030 MAXIMUM DEPTH (FEET) = 2.00
CHANNEL FLOW THRU SUBAREA (CFS) = 0.12
FLOW VELOCITY (FEET/SEC.) = 0.55 FLOW DEPTH (FEET) = 0.02
TRAVEL TIME (MIN.) = 15.92 Tc (MIN.) = 26.77
LONGEST FLOWPATH FROM NODE 2130.00 TO NODE 2132.00 = 600.00 FEET.

FLOW PROCESS FROM NODE 2132.00 TO NODE 2133.00 IS CODE = 81

>>>>ADDITION OF SUBAREA TO MAINLINE PEAK FLOW<<<<<

=====

50 YEAR RAINFALL INTENSITY (INCH/HOUR) = 1.518
GRASS FAIR COVER RUNOFF COEFFICIENT = .4500
SOIL CLASSIFICATION IS "D"
S.C.S. CURVE NUMBER (AMC II) = 84
SUBAREA AREA (ACRES) = 61.40 SUBAREA RUNOFF (CFS) = 41.94
TOTAL AREA (ACRES) = 61.50 TOTAL RUNOFF (CFS) = 42.06
TC (MIN.) = 26.77

FLOW PROCESS FROM NODE 0.00 TO NODE 0.00 IS CODE = 13

```

-----
>>>>CLEAR THE MAIN-STREAM MEMORY<<<<<
=====
*****
FLOW PROCESS FROM NODE    2140.00 TO NODE    2141.00 IS CODE =  21
-----
>>>>RATIONAL METHOD INITIAL SUBAREA ANALYSIS<<<<<
=====
GRASS FAIR COVER RUNOFF COEFFICIENT = .4500
SOIL CLASSIFICATION IS "D"
S.C.S. CURVE NUMBER (AMC II) =  84
NATURAL WATERSHED NOMOGRAPH TIME OF CONCENTRATION (APPENDIX X-A)
WITH 10-MIN. ADDED =  10.85 (MIN.)
INITIAL SUBAREA FLOW-LENGTH (FEET) =    70.00
UPSTREAM ELEVATION (FEET) =    125.00
DOWNSTREAM ELEVATION (FEET) =    123.25
ELEVATION DIFFERENCE (FEET) =     1.75
NATURAL WATERSHED TIME OF CONCENTRATION =  10.85
  50 YEAR RAINFALL INTENSITY (INCH/HOUR) =  2.717
SUBAREA RUNOFF (CFS) =     0.12
TOTAL AREA (ACRES) =     0.10  TOTAL RUNOFF (CFS) =     0.12
-----
*****
FLOW PROCESS FROM NODE    2141.00 TO NODE    2142.00 IS CODE =  51
-----
>>>>COMPUTE TRAPEZOIDAL CHANNEL FLOW<<<<<
>>>>TRAVELTIME THRU SUBAREA (EXISTING ELEMENT) <<<<<
=====
CHANNEL LENGTH THRU SUBAREA (FEET) =  930.00
REPRESENTATIVE CHANNEL SLOPE =  0.0250
CHANNEL BASE (FEET) =  10.00  "Z" FACTOR =  50.000
MANNING'S FACTOR =  0.030  MAXIMUM DEPTH (FEET) =  2.00
CHANNEL FLOW THRU SUBAREA (CFS) =     0.12
FLOW VELOCITY (FEET/SEC.) =  0.55  FLOW DEPTH (FEET) =  0.02
TRAVEL TIME (MIN.) =  27.93  Tc (MIN.) =  38.78
LONGEST FLOWPATH FROM NODE    2140.00 TO NODE    2142.00 =  1000.00 FEET.
-----
*****
FLOW PROCESS FROM NODE    2142.00 TO NODE    2143.00 IS CODE =  81
-----
>>>>ADDITION OF SUBAREA TO MAINLINE PEAK FLOW<<<<<
=====
  50 YEAR RAINFALL INTENSITY (INCH/HOUR) =  1.195
GRASS FAIR COVER RUNOFF COEFFICIENT = .4500
SOIL CLASSIFICATION IS "D"
S.C.S. CURVE NUMBER (AMC II) =  84
SUBAREA AREA (ACRES) =  48.30  SUBAREA RUNOFF (CFS) =  25.97
TOTAL AREA (ACRES) =  48.40  TOTAL RUNOFF (CFS) =  26.10
TC (MIN.) =  38.78
-----
*****
FLOW PROCESS FROM NODE    0.00 TO NODE    0.00 IS CODE =  13
-----
>>>>CLEAR THE MAIN-STREAM MEMORY<<<<<
=====

```

FLOW PROCESS FROM NODE 2150.00 TO NODE 2151.00 IS CODE = 21

>>>>RATIONAL METHOD INITIAL SUBAREA ANALYSIS<<<<<

=====

GRASS FAIR COVER RUNOFF COEFFICIENT =	.4500
SOIL CLASSIFICATION IS "D"	
S.C.S. CURVE NUMBER (AMC II) =	84
NATURAL WATERSHED NOMOGRAPH TIME OF CONCENTRATION (APPENDIX X-A)	
WITH 10-MIN. ADDED =	10.85 (MIN.)
INITIAL SUBAREA FLOW-LENGTH (FEET) =	7000
UPSTREAM ELEVATION (FEET) =	150.00
DOWNSTREAM ELEVATION (FEET) =	148.25
ELEVATION DIFFERENCE (FEET) =	1.75
NATURAL WATERSHED TIME OF CONCENTRATION =	10.85
50 YEAR RAINFALL INTENSITY (INCH/HOUR) =	2.717
SUBAREA RUNOFF (CFS) =	0.12
TOTAL AREA (ACRES) =	0.10
TOTAL RUNOFF (CFS) =	0.12

FLOW PROCESS FROM NODE 2151.00 TO NODE 2152.00 IS CODE = 51

>>>>COMPUTE TRAPEZOIDAL CHANNEL FLOW<<<<<
>>>>TRAVELTIME THRU SUBAREA (EXISTING ELEMENT) <<<<<

=====

CHANNEL LENGTH THRU SUBAREA (FEET) =	1930.00
REPRESENTATIVE CHANNEL SLOPE =	0.0250
CHANNEL BASE (FEET) =	10.00
"Z" FACTOR =	50.000
MANNING'S FACTOR =	0.030
MAXIMUM DEPTH (FEET) =	2.00
CHANNEL FLOW THRU SUBAREA (CFS) =	0.12
FLOW VELOCITY (FEET/SEC.) =	0.55
FLOW DEPTH (FEET) =	0.02
TRAVEL TIME (MIN.) =	57.96
Tc (MIN.) =	68.81
LONGEST FLOWPATH FROM NODE 2150.00 TO NODE 2152.00 =	2000.00 FEET.

FLOW PROCESS FROM NODE 2152.00 TO NODE 2153.00 IS CODE = 81

>>>>ADDITION OF SUBAREA TO MAINLINE PEAK FLOW<<<<<

=====

50 YEAR RAINFALL INTENSITY (INCH/HOUR) =	0.826
GRASS FAIR COVER RUNOFF COEFFICIENT =	.4500
SOIL CLASSIFICATION IS "D"	
S.C.S. CURVE NUMBER (AMC II) =	84
SUBAREA AREA (ACRES) =	153.70
SUBAREA RUNOFF (CFS) =	57.10
TOTAL AREA (ACRES) =	153.80
TOTAL RUNOFF (CFS) =	57.22
TC (MIN.) =	68.81

FLOW PROCESS FROM NODE 0.00 TO NODE 0.00 IS CODE = 13

>>>>CLEAR THE MAIN-STREAM MEMORY<<<<<

FLOW PROCESS FROM NODE 2160.00 TO NODE 2161.00 IS CODE = 21

>>>>RATIONAL METHOD INITIAL SUBAREA ANALYSIS<<<<<

```

=====
GRASS FAIR COVER RUNOFF COEFFICIENT = .4500
SOIL CLASSIFICATION IS "D"
S.C.S. CURVE NUMBER (AMC II) = 84
NATURAL WATERSHED NOMOGRAPH TIME OF CONCENTRATION (APPENDIX X-A)
WITH 10-MIN. ADDED = 10.85 (MIN.)
INITIAL SUBAREA FLOW-LENGTH (FEET) = 70.00
UPSTREAM ELEVATION (FEET) = 160.00
DOWNSTREAM ELEVATION (FEET) = 158.25
ELEVATION DIFFERENCE (FEET) = 1.75
NATURAL WATERSHED TIME OF CONCENTRATION = 10.85
50 YEAR RAINFALL INTENSITY (INCH/HOUR) = 2.717
SUBAREA RUNOFF (CFS) = 0.12
TOTAL AREA (ACRES) = 0.10 TOTAL RUNOFF (CFS) = 0.12
=====

```

```

*****
FLOW PROCESS FROM NODE 2161.00 TO NODE 2162.00 IS CODE = 51
-----

```

```

>>>>COMPUTE TRAPEZOIDAL CHANNEL FLOW<<<<
>>>>TRAVELTIME THRU SUBAREA (EXISTING ELEMENT)<<<<
=====
CHANNEL LENGTH THRU SUBAREA (FEET) = 2330.00
REPRESENTATIVE CHANNEL SLOPE = 0.0250
CHANNEL BASE (FEET) = 10.00 "Z" FACTOR = 50.000
MANNING'S FACTOR = 0.030 MAXIMUM DEPTH (FEET) = 2.00
CHANNEL FLOW THRU SUBAREA (CFS) = 0.12
FLOW VELOCITY (FEET/SEC.) = 0.55 FLOW DEPTH (FEET) = 0.02
TRAVEL TIME (MIN.) = 69.97 Tc (MIN.) = 80.82
LONGEST FLOWPATH FROM NODE 2160.00 TO NODE 2162.00 = 2400.00 FEET.
=====

```

```

*****
FLOW PROCESS FROM NODE 2162.00 TO NODE 2163.00 IS CODE = 81
-----

```

```

>>>>ADDITION OF SUBAREA TO MAINLINE PEAK FLOW<<<<
=====
50 YEAR RAINFALL INTENSITY (INCH/HOUR) = 0.744
GRASS FAIR COVER RUNOFF COEFFICIENT = .4500
SOIL CLASSIFICATION IS "D"
S.C.S. CURVE NUMBER (AMC II) = 84
SUBAREA AREA (ACRES) = 121.60 SUBAREA RUNOFF (CFS) = 40.72
TOTAL AREA (ACRES) = 121.70 TOTAL RUNOFF (CFS) = 40.84
TC (MIN.) = 80.82
=====

```

```

*****
FLOW PROCESS FROM NODE 0.00 TO NODE 0.00 IS CODE = 13
-----

```

```

>>>>CLEAR THE MAIN-STREAM MEMORY<<<<
=====

```

```

*****
FLOW PROCESS FROM NODE 2170.00 TO NODE 2171.00 IS CODE = 21
-----

```

```

>>>>RATIONAL METHOD INITIAL SUBAREA ANALYSIS<<<<
=====
GRASS FAIR COVER RUNOFF COEFFICIENT = .4500
SOIL CLASSIFICATION IS "D"
S.C.S. CURVE NUMBER (AMC II) = 84

```

NATURAL WATERSHED NOMOGRAPH TIME OF CONCENTRATION (APPENDIX X-A)
WITH 10-MIN. ADDED = 10.85 (MIN.)
INITIAL SUBAREA FLOW-LENGTH (FEET) = 70.00
UPSTREAM ELEVATION (FEET) = 175.00
DOWNSTREAM ELEVATION (FEET) = 173.25
ELEVATION DIFFERENCE (FEET) = 1.75
NATURAL WATERSHED TIME OF CONCENTRATION = 10.85
50 YEAR RAINFALL INTENSITY (INCH/HOUR) = 2.717
SUBAREA RUNOFF (CFS) = 0.12
TOTAL AREA (ACRES) = 0.10 TOTAL RUNOFF (CFS) = 0.12

FLOW PROCESS FROM NODE 2171.00 TO NODE 2172.00 IS CODE = 51

>>>> COMPUTE TRAPEZOIDAL CHANNEL FLOW<<<<<
>>>> TRAVELTIME THRU SUBAREA (EXISTING ELEMENT) <<<<<

=====

CHANNEL LENGTH THRU SUBAREA (FEET)	=	2930.00
REPRESENTATIVE CHANNEL SLOPE	=	0.0250
CHANNEL BASE (FEET)	=	10.00
"Z" FACTOR	=	50.0000
MANNING'S FACTOR	=	0.030
MAXIMUM DEPTH (FEET)	=	2.00
CHANNEL FLOW THRU SUBAREA (CFS)	=	0.12
FLOW VELOCITY (FEET/SEC.)	=	0.55
FLOW DEPTH (FEET)	=	0.02
TRAVEL TIME (MIN.)	=	87.99
Tc (MIN.)	=	98.84
LONGEST FLOWPATH FROM NODE 2170.00 TO NODE 2172.00	=	3000.00 FEET.

FLOW PROCESS FROM NODE 2172.00 TO NODE 2173.00 IS CODE = 81

>>>> ADDITION OF SUBAREA TO MAINLINE PEAK FLOW<<<<<

=====

50 YEAR RAINFALL INTENSITY (INCH/HOUR)	=	0.654
GRASS FAIR COVER RUNOFF COEFFICIENT	=	.4500
SOIL CLASSIFICATION IS "D"		
S.C.S. CURVE NUMBER (AMC II)	=	84
SUBAREA AREA (ACRES)	=	60.20
SUBAREA RUNOFF (CFS)	=	17.70
TOTAL AREA (ACRES)	=	60.30
TOTAL RUNOFF (CFS)	=	17.83
TC (MIN.)	=	98.84

FLOW PROCESS FROM NODE 0.00 TO NODE 0.00 IS CODE = 13

>>>> CLEAR THE MAIN-STREAM MEMORY<<<<<

FLOW PROCESS FROM NODE 9990.00 TO NODE 9991.00 IS CODE = 21

>>>> RATIONAL METHOD INITIAL SUBAREA ANALYSIS<<<<<

=====

GRASS FAIR COVER RUNOFF COEFFICIENT	=	.4500
SOIL CLASSIFICATION IS "D"		
S.C.S. CURVE NUMBER (AMC II)	=	84
NATURAL WATERSHED NOMOGRAPH TIME OF CONCENTRATION (APPENDIX X-A) WITH 10-MIN. ADDED	=	10.85 (MIN.)
INITIAL SUBAREA FLOW-LENGTH (FEET)	=	70.00
UPSTREAM ELEVATION (FEET)	=	1300.00

DOWNSTREAM ELEVATION (FEET) = 1298.25
ELEVATION DIFFERENCE (FEET) = 1.75
NATURAL WATERSHED TIME OF CONCENTRATION = 10.85
50 YEAR RAINFALL INTENSITY (INCH/HOUR) = 2.717
SUBAREA RUNOFF (CFS) = 0.12
TOTAL AREA (ACRES) = 0.10 TOTAL RUNOFF (CFS) = 0.12

FLOW PROCESS FROM NODE 9991.00 TO NODE 9992.00 IS CODE = 51

>>>>COMPUTE TRAPEZOIDAL CHANNEL FLOW<<<<<
>>>>TRAVELTIME THRU SUBAREA (EXISTING ELEMENT)<<<<<

=====

CHANNEL LENGTH THRU SUBAREA (FEET)	=	9930.00
REPRESENTATIVE CHANNEL SLOPE	=	0.0300
CHANNEL BASE (FEET)	=	10.00 "Z" FACTOR = 50.000
MANNING'S FACTOR	=	0.030 MAXIMUM DEPTH (FEET) = 2.00
CHANNEL FLOW THRU SUBAREA (CFS)	=	0.12
FLOW VELOCITY (FEET/SEC.)	=	0.55 FLOW DEPTH (FEET) = 0.02
TRAVEL TIME (MIN.)	=	298.21 Tc (MIN.) = 309.06
LONGEST FLOWPATH FROM NODE	9990.00 TO NODE	9992.00 = 10000.00 FEET.

FLOW PROCESS FROM NODE 9992.00 TO NODE 9993.00 IS CODE = 81

>>>>ADDITION OF SUBAREA TO MAINLINE PEAK FLOW<<<<<

=====

50 YEAR RAINFALL INTENSITY (INCH/HOUR)	=	0.313
GRASS FAIR COVER RUNOFF COEFFICIENT	=	.4500
SOIL CLASSIFICATION IS	"D"	
S.C.S. CURVE NUMBER (AMC II)	=	84
SUBAREA AREA (ACRES)	=	774.70 SUBAREA RUNOFF (CFS) = 109.22
TOTAL AREA (ACRES)	=	774.80 TOTAL RUNOFF (CFS) = 109.34
TC (MIN.)	=	309.06

END OF STUDY SUMMARY:

TOTAL AREA (ACRES)	=	774.80	TC (MIN.)	=	309.06
PEAK FLOW RATE (CFS)	=	109.34			

END OF RATIONAL METHOD ANALYSIS

RATIONAL METHOD HYDROLOGY COMPUTER PROGRAM PACKAGE
Reference: SAN DIEGO COUNTY FLOOD CONTROL DISTRICT
2003,1985,1981 HYDROLOGY MANUAL
(c) Copyright 1982-2003 Advanced Engineering Software (aes)
Ver. 1.5A Release Date: 01/01/2003 License ID 1499

Analysis prepared by:

Kimley-Horn and Associates San Diego
517 4th Avenue Suite 301
San Diego, California 92101
(619) 234-9411 Fax (619) 234-9433

***** DESCRIPTION OF STUDY *****
* Otay Mesa Watershed Analysis *
* 100 Year Storm Event P=1.90 *
* 5/20/05 AMC *

FILE NAME: C:\Drainage\407000\CPU100yr.DAT
TIME/DATE OF STUDY: 11:16 05/20/2005

USER SPECIFIED HYDROLOGY AND HYDRAULIC MODEL INFORMATION:

2003 SAN DIEGO MANUAL CRITERIA

USER SPECIFIED STORM EVENT(YEAR) = 100.00
6-HOUR DURATION PRECIPITATION (INCHES) = 1.900
SPECIFIED MINIMUM PIPE SIZE(INCH) = 18.00
SPECIFIED PERCENT OF GRADIENTS(DECIMAL) TO USE FOR FRICTION SLOPE = 1.00
SAN DIEGO HYDROLOGY MANUAL "C"-VALUES USED FOR RATIONAL METHOD
NOTE: USE MODIFIED RATIONAL METHOD PROCEDURES FOR CONFLUENCE ANALYSIS

USER-DEFINED STREET-SECTIONS FOR COUPLED PIPEFLOW AND STREETFLOW MODEL

Table with 9 columns: NO., HALF-WIDTH (FT), CROWN TO CROSSFALL (FT), STREET-CROSSFALL IN- / OUT- / SIDE / SIDE / WAY, CURB HEIGHT (FT), GUTTER WIDTH (FT), LIP (FT), GEOMETRIES HIKE (FT), MANNING FACTOR (n). Row 1: 1, 30.0, 20.0, 0.018/0.018/0.020, 0.67, 2.00, 0.0312, 0.167, 0.0150

GLOBAL STREET FLOW-DEPTH CONSTRAINTS:
1. Relative Flow-Depth = 0.00 FEET
as (Maximum Allowable Street Flow Depth) - (Top-of-Curb)
2. (Depth)*(Velocity) Constraint = 6.0 (FT*FT/S)
*SIZE PIPE WITH A FLOW CAPACITY GREATER THAN
OR EQUAL TO THE UPSTREAM TRIBUTARY PIPE.*

FLOW PROCESS FROM NODE 3100.00 TO NODE 3101.00 IS CODE = 21

>>>>RATIONAL METHOD INITIAL SUBAREA ANALYSIS<<<<<

=====
STREETS & ROADS (DITCHES) RUNOFF COEFFICIENT = .7100
SOIL CLASSIFICATION IS "D"
S.C.S. CURVE NUMBER (AMC II) = 93

INITIAL SUBAREA FLOW-LENGTH(FEET) = 70.00
UPSTREAM ELEVATION(FEET) = 106.00
DOWNSTREAM ELEVATION(FEET) = 104.32
ELEVATION DIFFERENCE(FEET) = 1.68
SUBAREA OVERLAND TIME OF FLOW(MIN.) = 4.387
100 YEAR RAINFALL INTENSITY(INCH/HOUR) = 5.006
NOTE: RAINFALL INTENSITY IS BASED ON Tc = 5-MINUTE.
SUBAREA RUNOFF(CFS) = 0.36
TOTAL AREA(ACRES) = 0.10 TOTAL RUNOFF(CFS) = 0.36

FLOW PROCESS FROM NODE 3101.00 TO NODE 3102.00 IS CODE = 51

>>>>COMPUTE TRAPEZOIDAL CHANNEL FLOW<<<<<
>>>>TRAVELTIME THRU SUBAREA (EXISTING ELEMENT)<<<<<

=====

CHANNEL LENGTH THRU SUBAREA(FEET)	=	180.00
REPRESENTATIVE CHANNEL SLOPE	=	0.0240
CHANNEL BASE(FEET)	=	10.00 "Z" FACTOR = 50.000
MANNING'S FACTOR = 0.030	MAXIMUM DEPTH(FEET)	= 2.00
CHANNEL FLOW THRU SUBAREA(CFS)	=	0.36
FLOW VELOCITY(FEET/SEC.)	=	0.86
FLOW DEPTH(FEET)	=	0.04
TRAVEL TIME(MIN.)	=	3.50
Tc(MIN.)	=	7.89
LONGEST FLOWPATH FROM NODE 3100.00 TO NODE 3102.00	=	250.00 FEET.

FLOW PROCESS FROM NODE 3102.00 TO NODE 3103.00 IS CODE = 81

>>>>ADDITION OF SUBAREA TO MAINLINE PEAK FLOW<<<<<

=====

100 YEAR RAINFALL INTENSITY(INCH/HOUR)	=	3.730
STREETS & ROADS (DITCHES) RUNOFF COEFFICIENT	=	.7100
SOIL CLASSIFICATION IS "D"		
S.C.S. CURVE NUMBER (AMC II)	=	93
AREA-AVERAGE RUNOFF COEFFICIENT	=	0.7100
SUBAREA AREA(ACRES)	=	19.30
SUBAREA RUNOFF(CFS)	=	51.11
TOTAL AREA(ACRES)	=	19.40
TOTAL RUNOFF(CFS)	=	51.37
TC(MIN.)	=	7.89

FLOW PROCESS FROM NODE 0.00 TO NODE 0.00 IS CODE = 13

>>>>CLEAR THE MAIN-STREAM MEMORY<<<<<

FLOW PROCESS FROM NODE 3110.00 TO NODE 3111.00 IS CODE = 21

>>>>RATIONAL METHOD INITIAL SUBAREA ANALYSIS<<<<<

=====

STREETS & ROADS (DITCHES) RUNOFF COEFFICIENT	=	.7100
SOIL CLASSIFICATION IS "D"		
S.C.S. CURVE NUMBER (AMC II)	=	93
INITIAL SUBAREA FLOW-LENGTH(FEET)	=	70.00
UPSTREAM ELEVATION(FEET)	=	110.00
DOWNSTREAM ELEVATION(FEET)	=	108.25
ELEVATION DIFFERENCE(FEET)	=	1.75

SUBAREA OVERLAND TIME OF FLOW(MIN.) = 4.328
100 YEAR RAINFALL INTENSITY(INCH/HOUR) = 5.006
NOTE: RAINFALL INTENSITY IS BASED ON Tc = 5-MINUTE.
SUBAREA RUNOFF(CFS) = 0.36
TOTAL AREA(ACRES) = 0.10 TOTAL RUNOFF(CFS) = 0.36

FLOW PROCESS FROM NODE 3111.00 TO NODE 3112.00 IS CODE = 51

>>>>COMPUTE TRAPEZOIDAL CHANNEL FLOW<<<<<
>>>>TRAVELTIME THRU SUBAREA (EXISTING ELEMENT)<<<<<

=====

CHANNEL LENGTH THRU SUBAREA(FEET)	=	330.00
REPRESENTATIVE CHANNEL SLOPE	=	0.0250
CHANNEL BASE(FEET)	=	10.00 "Z" FACTOR = 50.000
MANNING'S FACTOR	=	0.030 MAXIMUM DEPTH(FEET) = 2.00
CHANNEL FLOW THRU SUBAREA(CFS)	=	0.36
FLOW VELOCITY(FEET/SEC.)	=	0.86 FLOW DEPTH(FEET) = 0.04
TRAVEL TIME(MIN.)	=	6.42 Tc(MIN.) = 10.75
LONGEST FLOWPATH FROM NODE	3110.00 TO NODE	3112.00 = 400.00 FEET.

FLOW PROCESS FROM NODE 3112.00 TO NODE 3113.00 IS CODE = 81

>>>>ADDITION OF SUBAREA TO MAINLINE PEAK FLOW<<<<<

=====

100 YEAR RAINFALL INTENSITY(INCH/HOUR)	=	3.055
STREETS & ROADS (DITCHES) RUNOFF COEFFICIENT	=	.7100
SOIL CLASSIFICATION IS	"D"	
S.C.S. CURVE NUMBER (AMC II)	=	93
AREA-AVERAGE RUNOFF COEFFICIENT	=	0.7100
SUBAREA AREA(ACRES)	=	14.70 SUBAREA RUNOFF(CFS) = 31.89
TOTAL AREA(ACRES)	=	14.80 TOTAL RUNOFF(CFS) = 32.10
TC(MIN.)	=	10.75

FLOW PROCESS FROM NODE 0.00 TO NODE 0.00 IS CODE = 13

>>>>CLEAR THE MAIN-STREAM MEMORY<<<<<

FLOW PROCESS FROM NODE 3200.00 TO NODE 3201.00 IS CODE = 21

>>>>RATIONAL METHOD INITIAL SUBAREA ANALYSIS<<<<<

=====

STREETS & ROADS (DITCHES) RUNOFF COEFFICIENT	=	.7100
SOIL CLASSIFICATION IS	"D"	
S.C.S. CURVE NUMBER (AMC II)	=	93
INITIAL SUBAREA FLOW-LENGTH(FEET)	=	70.00
UPSTREAM ELEVATION(FEET)	=	122.00
DOWNSTREAM ELEVATION(FEET)	=	120.29
ELEVATION DIFFERENCE(FEET)	=	1.71
SUBAREA OVERLAND TIME OF FLOW(MIN.)	=	4.361
100 YEAR RAINFALL INTENSITY(INCH/HOUR)	=	5.006
NOTE: RAINFALL INTENSITY IS BASED ON Tc	=	5-MINUTE.
SUBAREA RUNOFF(CFS)	=	0.36

TOTAL AREA(ACRES) = 0.10 TOTAL RUNOFF(CFS) = 0.36

FLOW PROCESS FROM NODE 3201.00 TO NODE 3202.00 IS CODE = 51

>>>>COMPUTE TRAPEZOIDAL CHANNEL FLOW<<<<<
>>>>TRAVELTIME THRU SUBAREA (EXISTING ELEMENT)<<<<<

=====

CHANNEL LENGTH THRU SUBAREA (FEET)	=	830.00
REPRESENTATIVE CHANNEL SLOPE	=	0.0240
CHANNEL BASE (FEET)	=	10.00
"Z" FACTOR	=	50.000
MANNING'S FACTOR	=	0.030
MAXIMUM DEPTH (FEET)	=	2.00
CHANNEL FLOW THRU SUBAREA (CFS)	=	0.36
FLOW VELOCITY (FEET/SEC.)	=	0.86
FLOW DEPTH (FEET)	=	0.04
TRAVEL TIME (MIN.)	=	16.16
Tc (MIN.)	=	20.52
LONGEST FLOWPATH FROM NODE 3200.00 TO NODE 3202.00	=	900.00 FEET.

FLOW PROCESS FROM NODE 3202.00 TO NODE 3203.00 IS CODE = 81

>>>>ADDITION OF SUBAREA TO MAINLINE PEAK FLOW<<<<<

=====

100 YEAR RAINFALL INTENSITY (INCH/HOUR)	=	2.014
STREETS & ROADS (DITCHES) RUNOFF COEFFICIENT	=	.7100
SOIL CLASSIFICATION IS	=	"D"
S.C.S. CURVE NUMBER (AMC II)	=	93
AREA-AVERAGE RUNOFF COEFFICIENT	=	0.7100
SUBAREA AREA (ACRES)	=	47.00
SUBAREA RUNOFF (CFS)	=	67.20
TOTAL AREA (ACRES)	=	47.10
TOTAL RUNOFF (CFS)	=	67.34
TC (MIN.)	=	20.52

FLOW PROCESS FROM NODE 0.00 TO NODE 0.00 IS CODE = 13

>>>>CLEAR THE MAIN-STREAM MEMORY<<<<<

FLOW PROCESS FROM NODE 3300.00 TO NODE 3301.00 IS CODE = 21

>>>>RATIONAL METHOD INITIAL SUBAREA ANALYSIS<<<<<

=====

STREETS & ROADS (DITCHES) RUNOFF COEFFICIENT	=	.7100
SOIL CLASSIFICATION IS	=	"D"
S.C.S. CURVE NUMBER (AMC II)	=	93
INITIAL SUBAREA FLOW-LENGTH (FEET)	=	70.00
UPSTREAM ELEVATION (FEET)	=	108.00
DOWNSTREAM ELEVATION (FEET)	=	106.13
ELEVATION DIFFERENCE (FEET)	=	1.87
SUBAREA OVERLAND TIME OF FLOW (MIN.)	=	4.233
100 YEAR RAINFALL INTENSITY (INCH/HOUR)	=	5.006
NOTE: RAINFALL INTENSITY IS BASED ON Tc = 5-MINUTE.		
SUBAREA RUNOFF (CFS)	=	0.36
TOTAL AREA (ACRES)	=	0.10
TOTAL RUNOFF (CFS)	=	0.36

FLOW PROCESS FROM NODE 3201.00 TO NODE 3202.00 IS CODE = 51

```

-----
>>>>COMPUTE TRAPEZOIDAL CHANNEL FLOW<<<<<
>>>>TRAVELTIME THRU SUBAREA (EXISTING ELEMENT)<<<<<
=====
CHANNEL LENGTH THRU SUBAREA (FEET) = 230.00
REPRESENTATIVE CHANNEL SLOPE = 0.0267
CHANNEL BASE (FEET) = 10.00 "Z" FACTOR = 50.000
MANNING'S FACTOR = 0.030 MAXIMUM DEPTH (FEET) = 2.00
CHANNEL FLOW THRU SUBAREA (CFS) = 0.36
FLOW VELOCITY (FEET/SEC.) = 0.86 FLOW DEPTH (FEET) = 0.04
TRAVEL TIME (MIN.) = 4.48 Tc (MIN.) = 8.71
LONGEST FLOWPATH FROM NODE 3300.00 TO NODE 3202.00 = 300.00 FEET.

*****
FLOW PROCESS FROM NODE 3302.00 TO NODE 3303.00 IS CODE = 81
-----
>>>>ADDITION OF SUBAREA TO MAINLINE PEAK FLOW<<<<<
=====
100 YEAR RAINFALL INTENSITY (INCH/HOUR) = 3.500
STREETS & ROADS (DITCHES) RUNOFF COEFFICIENT = .7100
SOIL CLASSIFICATION IS "D"
S.C.S. CURVE NUMBER (AMC II) = 93
AREA-AVERAGE RUNOFF COEFFICIENT = 0.7100
SUBAREA AREA (ACRES) = 11.70 SUBAREA RUNOFF (CFS) = 29.07
TOTAL AREA (ACRES) = 11.80 TOTAL RUNOFF (CFS) = 29.32
TC (MIN.) = 8.71 :

*****
FLOW PROCESS FROM NODE 0.00 TO NODE 0.00 IS CODE = 13
-----
>>>>CLEAR THE MAIN-STREAM MEMORY<<<<<
=====
*****
FLOW PROCESS FROM NODE 3400.00 TO NODE 3401.00 IS CODE = 21
-----
>>>>RATIONAL METHOD INITIAL SUBAREA ANALYSIS<<<<<
=====
STREETS & ROADS (DITCHES) RUNOFF COEFFICIENT = .7100
SOIL CLASSIFICATION IS "D"
S.C.S. CURVE NUMBER (AMC II) = 93
INITIAL SUBAREA FLOW-LENGTH (FEET) = 70.00
UPSTREAM ELEVATION (FEET) = 118.00
DOWNSTREAM ELEVATION (FEET) = 116.20
ELEVATION DIFFERENCE (FEET) = 1.80
SUBAREA OVERLAND TIME OF FLOW (MIN.) = 4.287
100 YEAR RAINFALL INTENSITY (INCH/HOUR) = 5.006
NOTE: RAINFALL INTENSITY IS BASED ON Tc = 5-MINUTE.
SUBAREA RUNOFF (CFS) = 0.36
TOTAL AREA (ACRES) = 0.10 TOTAL RUNOFF (CFS) = 0.36

*****
FLOW PROCESS FROM NODE 3401.00 TO NODE 3402.00 IS CODE = 51
-----
>>>>COMPUTE TRAPEZOIDAL CHANNEL FLOW<<<<<
>>>>TRAVELTIME THRU SUBAREA (EXISTING ELEMENT)<<<<<
=====

```

CHANNEL LENGTH THRU SUBAREA (FEET) = 630.00
REPRESENTATIVE CHANNEL SLOPE = 0.0257
CHANNEL BASE (FEET) = 10.00 "Z" FACTOR = 50.000
MANNING'S FACTOR = 0.030 MAXIMUM DEPTH (FEET) = 2.00
CHANNEL FLOW THRU SUBAREA (CFS) = 0.36
FLOW VELOCITY (FEET/SEC.) = 0.86 FLOW DEPTH (FEET) = 0.04
TRAVEL TIME (MIN.) = 12.26 Tc (MIN.) = 16.55
LONGEST FLOWPATH FROM NODE 3400.00 TO NODE 3402.00 = 700.00 FEET.

FLOW PROCESS FROM NODE 3402.00 TO NODE 3403.00 IS CODE = 81

>>>> ADDITION OF SUBAREA TO MAINLINE PEAK FLOW <<<<<

=====

100 YEAR RAINFALL INTENSITY (INCH/HOUR) = 2.313
STREETS & ROADS (DITCHES) RUNOFF COEFFICIENT = .7100
SOIL CLASSIFICATION IS "D"
S.C.S. CURVE NUMBER (AMC II) = 93
AREA-AVERAGE RUNOFF COEFFICIENT = 0.7100
SUBAREA AREA (ACRES) = 34.90 SUBAREA RUNOFF (CFS) = 57.32
TOTAL AREA (ACRES) = 35.00 TOTAL RUNOFF (CFS) = 57.48
TC (MIN.) = 16.55

FLOW PROCESS FROM NODE 0.00 TO NODE 0.00 IS CODE = 13

>>>> CLEAR THE MAIN-STREAM MEMORY <<<<<

FLOW PROCESS FROM NODE 3500.00 TO NODE 3501.00 IS CODE = 21

>>>> RATIONAL METHOD INITIAL SUBAREA ANALYSIS <<<<<

=====

STREETS & ROADS (DITCHES) RUNOFF COEFFICIENT = .7100
SOIL CLASSIFICATION IS "D"
S.C.S. CURVE NUMBER (AMC II) = 93
INITIAL SUBAREA FLOW-LENGTH (FEET) = 70.00
UPSTREAM ELEVATION (FEET) = 110.00
DOWNSTREAM ELEVATION (FEET) = 108.25
ELEVATION DIFFERENCE (FEET) = 1.75
SUBAREA OVERLAND TIME OF FLOW (MIN.) = 4.328
100 YEAR RAINFALL INTENSITY (INCH/HOUR) = 5.006
NOTE: RAINFALL INTENSITY IS BASED ON Tc = 5-MINUTE.
SUBAREA RUNOFF (CFS) = 0.36
TOTAL AREA (ACRES) = 0.10 TOTAL RUNOFF (CFS) = 0.36

FLOW PROCESS FROM NODE 3501.00 TO NODE 3502.00 IS CODE = 51

>>>> COMPUTE TRAPEZOIDAL CHANNEL FLOW <<<<<
>>>> TRAVELTIME THRU SUBAREA (EXISTING ELEMENT) <<<<<

=====

CHANNEL LENGTH THRU SUBAREA (FEET) = 330.00
REPRESENTATIVE CHANNEL SLOPE = 0.0250
CHANNEL BASE (FEET) = 10.00 "Z" FACTOR = 50.000
MANNING'S FACTOR = 0.030 MAXIMUM DEPTH (FEET) = 2.00

CHANNEL FLOW THRU SUBAREA(CFS) = 0.36
FLOW VELOCITY(FEET/SEC.) = 0.86 FLOW DEPTH(FEET) = 0.04
TRAVEL TIME(MIN.) = 6.42 Tc(MIN.) = 10.75
LONGEST FLOWPATH FROM NODE 3500.00 TO NODE 3502.00 = 400.00 FEET.

FLOW PROCESS FROM NODE 3502.00 TO NODE 3503.00 IS CODE = 81

>>>>ADDITION OF SUBAREA TO MAINLINE PEAK FLOW<<<<<

=====

100 YEAR RAINFALL INTENSITY(INCH/HOUR) = 3.055
STREETS & ROADS (DITCHES) RUNOFF COEFFICIENT = .7100
SOIL CLASSIFICATION IS "D"
S.C.S. CURVE NUMBER (AMC II) = 93
AREA-AVERAGE RUNOFF COEFFICIENT = 0.7100
SUBAREA AREA(ACRES) = 16.40 SUBAREA RUNOFF(CFS) = 35.57
TOTAL AREA(ACRES) = 16.50 TOTAL RUNOFF(CFS) = 35.79
TC(MIN.) = 10.75

FLOW PROCESS FROM NODE 0.00 TO NODE 0.00 IS CODE = 13

>>>>CLEAR THE MAIN-STREAM MEMORY<<<<<

FLOW PROCESS FROM NODE 3600.00 TO NODE 3601.00 IS CODE = 21

>>>>RATIONAL METHOD INITIAL SUBAREA ANALYSIS<<<<<

=====

STREETS & ROADS (DITCHES) RUNOFF COEFFICIENT = .7100
SOIL CLASSIFICATION IS "D"
S.C.S. CURVE NUMBER (AMC II) = 93
INITIAL SUBAREA FLOW-LENGTH(FEET) = 70.00
UPSTREAM ELEVATION(FEET) = 108.00
DOWNSTREAM ELEVATION(FEET) = 106.13
ELEVATION DIFFERENCE(FEET) = 1.87
SUBAREA OVERLAND TIME OF FLOW(MIN.) = 4.233
100 YEAR RAINFALL INTENSITY(INCH/HOUR) = 5.006
NOTE: RAINFALL INTENSITY IS BASED ON Tc = 5-MINUTE.
SUBAREA RUNOFF(CFS) = 0.36
TOTAL AREA(ACRES) = 0.10 TOTAL RUNOFF(CFS) = 0.36

FLOW PROCESS FROM NODE 3601.00 TO NODE 3602.00 IS CODE = 51

>>>>COMPUTE TRAPEZOIDAL CHANNEL FLOW<<<<<
>>>>TRAVELTIME THRU SUBAREA (EXISTING ELEMENT) <<<<<

=====

CHANNEL LENGTH THRU SUBAREA(FEET) = 230.00
REPRESENTATIVE CHANNEL SLOPE = 0.0267
CHANNEL BASE(FEET) = 10.00 "Z" FACTOR = 50.000
MANNING'S FACTOR = 0.030 MAXIMUM DEPTH(FEET) = 2.00
CHANNEL FLOW THRU SUBAREA(CFS) = 0.36
FLOW VELOCITY(FEET/SEC.) = 0.86 FLOW DEPTH(FEET) = 0.04
TRAVEL TIME(MIN.) = 4.48 Tc(MIN.) = 8.71
LONGEST FLOWPATH FROM NODE 3600.00 TO NODE 3602.00 = 300.00 FEET.

FLOW PROCESS FROM NODE 3602.00 TO NODE 3603.00 IS CODE = 81

>>>>ADDITION OF SUBAREA TO MAINLINE PEAK FLOW<<<<<

=====

100 YEAR RAINFALL INTENSITY (INCH/HOUR) =	3.500
STREETS & ROADS (DITCHES) RUNOFF COEFFICIENT =	.7100
SOIL CLASSIFICATION IS	"D"
S.C.S. CURVE NUMBER (AMC II) =	93
AREA-AVERAGE RUNOFF COEFFICIENT =	0.7100
SUBAREA AREA (ACRES) =	12.10
SUBAREA RUNOFF (CFS) =	30.06
TOTAL AREA (ACRES) =	12.20
TOTAL RUNOFF (CFS) =	30.31
TC (MIN.) =	8.71

FLOW PROCESS FROM NODE 0.00 TO NODE 0.00 IS CODE = 13

>>>>CLEAR THE MAIN-STREAM MEMORY<<<<<

FLOW PROCESS FROM NODE 3700.00 TO NODE 3701.00 IS CODE = 21

>>>>RATIONAL METHOD INITIAL SUBAREA ANALYSIS<<<<<

=====

STREETS & ROADS (DITCHES) RUNOFF COEFFICIENT =	.7100
SOIL CLASSIFICATION IS	"D"
S.C.S. CURVE NUMBER (AMC II) =	93
INITIAL SUBAREA FLOW-LENGTH (FEET) =	70.00
UPSTREAM ELEVATION (FEET) =	120.00
DOWNSTREAM ELEVATION (FEET) =	118.25
ELEVATION DIFFERENCE (FEET) =	1.75
SUBAREA OVERLAND TIME OF FLOW (MIN.) =	4.328
100 YEAR RAINFALL INTENSITY (INCH/HOUR) =	5.006
NOTE: RAINFALL INTENSITY IS BASED ON Tc = 5-MINUTE.	
SUBAREA RUNOFF (CFS) =	0.36
TOTAL AREA (ACRES) =	0.10
TOTAL RUNOFF (CFS) =	0.36

FLOW PROCESS FROM NODE 3701.00 TO NODE 3702.00 IS CODE = 51

>>>>COMPUTE TRAPEZOIDAL CHANNEL FLOW<<<<<
>>>>TRAVELTIME THRU SUBAREA (EXISTING ELEMENT)<<<<<

=====

CHANNEL LENGTH THRU SUBAREA (FEET) =	730.00
REPRESENTATIVE CHANNEL SLOPE =	0.0250
CHANNEL BASE (FEET) =	10.00
"Z" FACTOR =	50.000
MANNING'S FACTOR =	0.030
MAXIMUM DEPTH (FEET) =	2.00
CHANNEL FLOW THRU SUBAREA (CFS) =	0.36
FLOW VELOCITY (FEET/SEC.) =	0.86
FLOW DEPTH (FEET) =	0.04
TRAVEL TIME (MIN.) =	14.21
Tc (MIN.) =	18.54
LONGEST FLOWPATH FROM NODE 3700.00 TO NODE 3702.00 =	800.00 FEET.

FLOW PROCESS FROM NODE 3702.00 TO NODE 3703.00 IS CODE = 81

```

>>>>ADDITION OF SUBAREA TO MAINLINE PEAK FLOW<<<<
=====
100 YEAR RAINFALL INTENSITY(INCH/HOUR) = 2.150
STREETS & ROADS (DITCHES) RUNOFF COEFFICIENT = .7100
SOIL CLASSIFICATION IS "D"
S.C.S. CURVE NUMBER (AMC II) = 93
AREA-AVERAGE RUNOFF COEFFICIENT = 0.7100
SUBAREA AREA(ACRES) = 46.00 SUBAREA RUNOFF(CFS) = 70.22
TOTAL AREA(ACRES) = 46.10 TOTAL RUNOFF(CFS) = 70.37
TC(MIN.) = 18.54
f
*****
FLOW PROCESS FROM NODE 0.00 TO NODE 0.00 IS CODE = 13
-----
>>>>CLEAR THE MAIN-STREAM MEMORY<<<<
=====
*****
FLOW PROCESS FROM NODE 3800.00 TO NODE 3801.00 IS CODE = 21
-----
>>>>RATIONAL METHOD INITIAL SUBAREA ANALYSIS<<<<
=====
STREETS & ROADS (DITCHES) RUNOFF COEFFICIENT = .7100
SOIL CLASSIFICATION IS "D"
S.C.S. CURVE NUMBER (AMC II) = 93
INITIAL SUBAREA FLOW-LENGTH( FEET) = 70.00
UPSTREAM ELEVATION( FEET) = 125.00
DOWNSTREAM ELEVATION( FEET) = 123.25
ELEVATION DIFFERENCE( FEET) = 1.75
SUBAREA OVERLAND TIME OF FLOW(MIN.) = 4.328
100 YEAR RAINFALL INTENSITY(INCH/HOUR) = 5.006
NOTE: RAINFALL INTENSITY IS BASED ON Tc = 5-MINUTE.
SUBAREA RUNOFF(CFS) = 0.36
TOTAL AREA(ACRES) = 0.10 TOTAL RUNOFF(CFS) = 0.36
z
*****
FLOW PROCESS FROM NODE 3801.00 TO NODE 3802.00 IS CODE = 51
-----
>>>>COMPUTE TRAPEZOIDAL CHANNEL FLOW<<<<
>>>>TRAVELTIME THRU SUBAREA (EXISTING ELEMENT) <<<<
=====
CHANNEL LENGTH THRU SUBAREA( FEET) = 930.00
REPRESENTATIVE CHANNEL SLOPE = 0.0250
CHANNEL BASE( FEET) = 10.00 "Z" FACTOR = 50.000
MANNING'S FACTOR = 0.030 MAXIMUM DEPTH( FEET) = 2.00
CHANNEL FLOW THRU SUBAREA(CFS) = 0.36
FLOW VELOCITY( FEET/SEC.) = 0.86 FLOW DEPTH( FEET) = 0.04
TRAVEL TIME(MIN.) = 18.10 Tc(MIN.) = 22.43
LONGEST FLOWPATH FROM NODE 3800.00 TO NODE 3802.00 = 1000.00 FEET.
f
*****
FLOW PROCESS FROM NODE 3802.00 TO NODE 3803.00 IS CODE = 81
-----
>>>>ADDITION OF SUBAREA TO MAINLINE PEAK FLOW<<<<
=====
100 YEAR RAINFALL INTENSITY(INCH/HOUR) = 1.901
STREETS & ROADS (DITCHES) RUNOFF COEFFICIENT = .7100

```

SOIL CLASSIFICATION IS "D"
S.C.S. CURVE NUMBER (AMC II) = 93
AREA-AVERAGE RUNOFF COEFFICIENT = 0.7100
SUBAREA AREA(ACRES) = 51.30 SUBAREA RUNOFF(CFS) = 69.25
TOTAL AREA(ACRES) = 51.40 TOTAL RUNOFF(CFS) = 69.38
TC(MIN.) = 22.43

FLOW PROCESS FROM NODE 0.00 TO NODE 0.00 IS CODE = 13

>>>>CLEAR THE MAIN-STREAM MEMORY<<<<<<
=====

FLOW PROCESS FROM NODE 2100.00 TO NODE 2101.00 IS CODE = 21

>>>>RATIONAL METHOD INITIAL SUBAREA ANALYSIS<<<<<<
=====

STREETS & ROADS (DITCHES) RUNOFF COEFFICIENT = .7100
SOIL CLASSIFICATION IS "D"
S.C.S. CURVE NUMBER (AMC II) = 93
INITIAL SUBAREA FLOW-LENGTH(FEET) = 70.00
UPSTREAM ELEVATION(FEET) = 128.00
DOWNSTREAM ELEVATION(FEET) = 126.22
ELEVATION DIFFERENCE(FEET) = 1.78
SUBAREA OVERLAND TIME OF FLOW(MIN.) = 4.303
100 YEAR RAINFALL INTENSITY(INCH/HOUR) = 5.006
NOTE: RAINFALL INTENSITY IS BASED ON Tc = 5-MINUTE.
SUBAREA RUNOFF(CFS) = 0.36
TOTAL AREA(ACRES) = 0.10 TOTAL RUNOFF(CFS) = 0.36

FLOW PROCESS FROM NODE 2101.00 TO NODE 2102.00 IS CODE = 51

>>>>COMPUTE TRAPEZOIDAL CHANNEL FLOW<<<<<<
>>>>TRAVELTIME THRU SUBAREA (EXISTING ELEMENT)<<<<<<
=====

CHANNEL LENGTH THRU SUBAREA(FEET) = 1030.00
REPRESENTATIVE CHANNEL SLOPE = 0.0255
CHANNEL BASE(FEET) = 10.00 "Z" FACTOR = 50.000
MANNING'S FACTOR = 0.030 MAXIMUM DEPTH(FEET) = 2.00
CHANNEL FLOW THRU SUBAREA(CFS) = 0.36
FLOW VELOCITY(FEET/SEC.) = 0.86 FLOW DEPTH(FEET) = 0.04
TRAVEL TIME(MIN.) = 20.05 Tc(MIN.) = 24.35
LONGEST FLOWPATH FROM NODE 2100.00 TO NODE 2102.00 = 1100.00 FEET.

FLOW PROCESS FROM NODE 2102.00 TO NODE 2103.00 IS CODE = 81

>>>>ADDITION OF SUBAREA TO MAINLINE PEAK FLOW<<<<<<
=====

100 YEAR RAINFALL INTENSITY(INCH/HOUR) = 1.803
STREETS & ROADS (DITCHES) RUNOFF COEFFICIENT = .7100
SOIL CLASSIFICATION IS "D"
S.C.S. CURVE NUMBER (AMC II) = 93
AREA-AVERAGE RUNOFF COEFFICIENT = 0.7100
SUBAREA AREA(ACRES) = 33.20 SUBAREA RUNOFF(CFS) = 42.50

TOTAL AREA(ACRES) = 33.30 TOTAL RUNOFF(CFS) = 42.63
TC(MIN.) = 24.35

FLOW PROCESS FROM NODE 0.00 TO NODE 0.00 IS CODE = 13

>>>>CLEAR THE MAIN-STREAM MEMORY<<<<<

FLOW PROCESS FROM NODE 2200.00 TO NODE 2201.00 IS CODE = 21

>>>>RATIONAL METHOD INITIAL SUBAREA ANALYSIS<<<<<

STREETS & ROADS (DITCHES) RUNOFF COEFFICIENT = .7100
SOIL CLASSIFICATION IS "D"
S.C.S. CURVE NUMBER (AMC II) = 93
INITIAL SUBAREA FLOW-LENGTH(FEET) = 70.00
UPSTREAM ELEVATION(FEET) = 163.00
DOWNSTREAM ELEVATION(FEET) = 161.24
ELEVATION DIFFERENCE(FEET) = 1.76
SUBAREA OVERLAND TIME OF FLOW(MIN.) = 4.319
100 YEAR RAINFALL INTENSITY(INCH/HOUR) = 5.006
NOTE: RAINFALL INTENSITY IS BASED ON Tc = 5-MINUTE.
SUBAREA RUNOFF(CFS) = 0.36
TOTAL AREA(ACRES) = 0.10 TOTAL RUNOFF(CFS) = 0.36

FLOW PROCESS FROM NODE 2201.00 TO NODE 2202.00 IS CODE = 51

>>>>COMPUTE TRAPEZOIDAL CHANNEL FLOW<<<<<
>>>>TRAVELTIME THRU SUBAREA (EXISTING ELEMENT)<<<<<

CHANNEL LENGTH THRU SUBAREA(FEET) = 2430.00
REPRESENTATIVE CHANNEL SLOPE = 0.0252
CHANNEL BASE(FEET) = 10.00 "Z" FACTOR = 50.000
MANNING'S FACTOR = 0.030 MAXIMUM DEPTH(FEET) = 2.00
CHANNEL FLOW THRU SUBAREA(CFS) = 0.36
FLOW VELOCITY(FEET/SEC.) = 0.86 FLOW DEPTH(FEET) = 0.04
TRAVEL TIME(MIN.) = 47.30 Tc(MIN.) = 51.62
LONGEST FLOWPATH FROM NODE 2200.00 TO NODE 2202.00 = 2500.00 FEET.

FLOW PROCESS FROM NODE 2202.00 TO NODE 2203.00 IS CODE = 81

>>>>ADDITION OF SUBAREA TO MAINLINE PEAK FLOW<<<<<

100 YEAR RAINFALL INTENSITY(INCH/HOUR) = 1.111
STREETS & ROADS (DITCHES) RUNOFF COEFFICIENT = .7100
SOIL CLASSIFICATION IS "D"
S.C.S. CURVE NUMBER (AMC II) = 93
AREA-AVERAGE RUNOFF COEFFICIENT = 0.7100
SUBAREA AREA(ACRES) = 126.10 SUBAREA RUNOFF(CFS) = 99.43
TOTAL AREA(ACRES) = 126.20 TOTAL RUNOFF(CFS) = 99.51
TC(MIN.) = 51.62

FLOW PROCESS FROM NODE 0.00 TO NODE 0.00 IS CODE = 13

>>>>CLEAR THE MAIN-STREAM MEMORY<<<<<

FLOW PROCESS FROM NODE 2180.00 TO NODE 2181.00 IS CODE = 21

>>>>RATIONAL METHOD INITIAL SUBAREA ANALYSIS<<<<<

STREETS & ROADS (DITCHES) RUNOFF COEFFICIENT = .7100
SOIL CLASSIFICATION IS "D"
S.C.S. CURVE NUMBER (AMC II) = 93
INITIAL SUBAREA FLOW-LENGTH (FEET) = 70.00
UPSTREAM ELEVATION (FEET) = 130.00
DOWNSTREAM ELEVATION (FEET) = 128.25
ELEVATION DIFFERENCE (FEET) = 1.75
SUBAREA OVERLAND TIME OF FLOW (MIN.) = 4.328
100 YEAR RAINFALL INTENSITY (INCH/HOUR) = 5.006
NOTE: RAINFALL INTENSITY IS BASED ON Tc = 5-MINUTE.
SUBAREA RUNOFF (CFS) = 0.36
TOTAL AREA (ACRES) = 0.10 TOTAL RUNOFF (CFS) = 0.36

FLOW PROCESS FROM NODE 2181.00 TO NODE 2182.00 IS CODE = 51

>>>>COMPUTE TRAPEZOIDAL CHANNEL FLOW<<<<<
>>>>TRAVELTIME THRU SUBAREA (EXISTING ELEMENT)<<<<<

CHANNEL LENGTH THRU SUBAREA (FEET) = 1130.00
REPRESENTATIVE CHANNEL SLOPE = 0.0250
CHANNEL BASE (FEET) = 10.00 "Z" FACTOR = 50.000
MANNING'S FACTOR = 0.030 MAXIMUM DEPTH (FEET) = 2.00
CHANNEL FLOW THRU SUBAREA (CFS) = 0.36
FLOW VELOCITY (FEET/SEC.) = 0.86 FLOW DEPTH (FEET) = 0.04
TRAVEL TIME (MIN.) = 22.00 Tc (MIN.) = 26.32
LONGEST FLOWPATH FROM NODE 2180.00 TO NODE 2182.00 = 1200.00 FEET.

FLOW PROCESS FROM NODE 2182.00 TO NODE 2183.00 IS CODE = 81

>>>>ADDITION OF SUBAREA TO MAINLINE PEAK FLOW<<<<<

100 YEAR RAINFALL INTENSITY (INCH/HOUR) = 1.715
STREETS & ROADS (DITCHES) RUNOFF COEFFICIENT = .7100
SOIL CLASSIFICATION IS "D"
S.C.S. CURVE NUMBER (AMC II) = 93
AREA-AVERAGE RUNOFF COEFFICIENT = 0.7100
SUBAREA AREA (ACRES) = 97.00 SUBAREA RUNOFF (CFS) = 118.10
TOTAL AREA (ACRES) = 97.10 TOTAL RUNOFF (CFS) = 118.22
TC (MIN.) = 26.32

FLOW PROCESS FROM NODE 0.00 TO NODE 0.00 IS CODE = 13

>>>>CLEAR THE MAIN-STREAM MEMORY<<<<<

FLOW PROCESS FROM NODE 2190.00 TO NODE 2191.00 IS CODE = 21

>>>>RATIONAL METHOD INITIAL SUBAREA ANALYSIS<<<<<

=====

STREETS & ROADS (DITCHES) RUNOFF COEFFICIENT =	.7100
SOIL CLASSIFICATION IS	"D"
S.C.S. CURVE NUMBER (AMC II) =	93
INITIAL SUBAREA FLOW-LENGTH (FEET) =	70.00
UPSTREAM ELEVATION (FEET) =	110.00
DOWNSTREAM ELEVATION (FEET) =	108.25
ELEVATION DIFFERENCE (FEET) =	1.75
SUBAREA OVERLAND TIME OF FLOW (MIN.) =	4.328
100 YEAR RAINFALL INTENSITY (INCH/HOUR) =	5.006
NOTE: RAINFALL INTENSITY IS BASED ON Tc =	5-MINUTE.
SUBAREA RUNOFF (CFS) =	0.36
TOTAL AREA (ACRES) =	0.10
TOTAL RUNOFF (CFS) =	0.36

FLOW PROCESS FROM NODE 2191.00 TO NODE 2192.00 IS CODE = 51

>>>>COMPUTE TRAPEZOIDAL CHANNEL FLOW<<<<<
>>>>TRAVELTIME THRU SUBAREA (EXISTING ELEMENT)<<<<<

=====

CHANNEL LENGTH THRU SUBAREA (FEET) =	330.00
REPRESENTATIVE CHANNEL SLOPE =	0.0250
CHANNEL BASE (FEET) =	10.00
"Z" FACTOR =	50.000
MANNING'S FACTOR =	0.030
MAXIMUM DEPTH (FEET) =	2.00
CHANNEL FLOW THRU SUBAREA (CFS) =	0.36
FLOW VELOCITY (FEET/SEC.) =	0.86
FLOW DEPTH (FEET) =	0.04
TRAVEL TIME (MIN.) =	6.42
Tc (MIN.) =	10.75
LONGEST FLOWPATH FROM NODE 2190.00 TO NODE 2192.00 =	400.00 FEET.

FLOW PROCESS FROM NODE 2192.00 TO NODE 2193.00 IS CODE = 81

>>>>ADDITION OF SUBAREA TO MAINLINE PEAK FLOW<<<<<

=====

100 YEAR RAINFALL INTENSITY (INCH/HOUR) =	3.055
STREETS & ROADS (DITCHES) RUNOFF COEFFICIENT =	.7100
SOIL CLASSIFICATION IS	"D"
S.C.S. CURVE NUMBER (AMC II) =	93
AREA-AVERAGE RUNOFF COEFFICIENT =	0.7100
SUBAREA AREA (ACRES) =	27.60
SUBAREA RUNOFF (CFS) =	59.87
TOTAL AREA (ACRES) =	27.70
TOTAL RUNOFF (CFS) =	60.09
TC (MIN.) =	10.75

FLOW PROCESS FROM NODE 0.00 TO NODE 0.00 IS CODE = 13

>>>>CLEAR THE MAIN-STREAM MEMORY<<<<<

FLOW PROCESS FROM NODE 2300.00 TO NODE 2301.00 IS CODE = 21

>>>>RATIONAL METHOD INITIAL SUBAREA ANALYSIS<<<<<

=====

STREETS & ROADS (DITCHES) RUNOFF COEFFICIENT = .7100
SOIL CLASSIFICATION IS "D"
S.C.S. CURVE NUMBER (AMC II) = 93
INITIAL SUBAREA FLOW-LENGTH(FEET) = 70.00
UPSTREAM ELEVATION(FEET) = 113.00
DOWNSTREAM ELEVATION(FEET) = 111.25
ELEVATION DIFFERENCE(FEET) = 1.75
SUBAREA OVERLAND TIME OF FLOW(MIN.) = 4.328
100 YEAR RAINFALL INTENSITY(INCH/HOUR) = 5.006
NOTE: RAINFALL INTENSITY IS BASED ON Tc = 5-MINUTE.
SUBAREA RUNOFF(CFS) = 0.36
TOTAL AREA(ACRES) = 0.10 TOTAL RUNOFF(CFS) = 0.36

FLOW PROCESS FROM NODE 2301.00 TO NODE 2302.00 IS CODE = 51

>>>>COMPUTE TRAPEZOIDAL CHANNEL FLOW<<<<<
>>>>TRAVELTIME THRU SUBAREA (EXISTING ELEMENT)<<<<<

=====

CHANNEL LENGTH THRU SUBAREA(FEET) = 450.00
REPRESENTATIVE CHANNEL SLOPE = 0.0250
CHANNEL BASE(FEET) = 10.00 "Z" FACTOR = 50.000
MANNING'S FACTOR = 0.030 MAXIMUM DEPTH(FEET) = 2.00
CHANNEL FLOW THRU SUBAREA(CFS) = 0.36
FLOW VELOCITY(FEET/SEC.) = 0.86 FLOW DEPTH(FEET) = 0.04
TRAVEL TIME(MIN.) = 8.76 Tc(MIN.) = 13.09
LONGEST FLOWPATH FROM NODE 2300.00 TO NODE 2302.00 = 520.00 FEET.

FLOW PROCESS FROM NODE 2302.00 TO NODE 2303.00 IS CODE = 81

>>>>ADDITION OF SUBAREA TO MAINLINE PEAK FLOW<<<<<

=====

100 YEAR RAINFALL INTENSITY(INCH/HOUR) = 2.691
STREETS & ROADS (DITCHES) RUNOFF COEFFICIENT = .7100
SOIL CLASSIFICATION IS "D"
S.C.S. CURVE NUMBER (AMC II) = 93
AREA-AVERAGE RUNOFF COEFFICIENT = 0.7100
SUBAREA AREA(ACRES) = 20.00 SUBAREA RUNOFF(CFS) = 38.22
TOTAL AREA(ACRES) = 20.10 TOTAL RUNOFF(CFS) = 38.41
TC(MIN.) = 13.09

FLOW PROCESS FROM NODE 0.00 TO NODE 0.00 IS CODE = 13

>>>>CLEAR THE MAIN-STREAM MEMORY<<<<<

FLOW PROCESS FROM NODE 2400.00 TO NODE 2401.00 IS CODE = 21

>>>>RATIONAL METHOD INITIAL SUBAREA ANALYSIS<<<<<

=====

STREETS & ROADS (DITCHES) RUNOFF COEFFICIENT = .7100
SOIL CLASSIFICATION IS "D"

S.C.S. CURVE NUMBER (AMC II) = 93
INITIAL SUBAREA FLOW-LENGTH (FEET) = 70.00
UPSTREAM ELEVATION (FEET) = 122.00
DOWNSTREAM ELEVATION (FEET) = 120.29
ELEVATION DIFFERENCE (FEET) = 1.71
SUBAREA OVERLAND TIME OF FLOW (MIN.) = 4.361
100 YEAR RAINFALL INTENSITY (INCH/HOUR) = 5.006
NOTE: RAINFALL INTENSITY IS BASED ON Tc = 5-MINUTE.
SUBAREA RUNOFF (CFS) = 0.36
TOTAL AREA (ACRES) = 0.10 TOTAL RUNOFF (CFS) = 0.36

FLOW PROCESS FROM NODE 2401.00 TO NODE 2402.00 IS CODE = 51

>>>>COMPUTE TRAPEZOIDAL CHANNEL FLOW<<<<<
>>>>TRAVELTIME THRU SUBAREA (EXISTING ELEMENT)<<<<<

=====

CHANNEL LENGTH THRU SUBAREA (FEET)	=	830.00
REPRESENTATIVE CHANNEL SLOPE	=	0.0244
CHANNEL BASE (FEET)	=	10.00 "Z" FACTOR = 50.000
MANNING'S FACTOR	=	0.030 MAXIMUM DEPTH (FEET) = 2.00
CHANNEL FLOW THRU SUBAREA (CFS)	=	0.36
FLOW VELOCITY (FEET/SEC.)	=	0.86 FLOW DEPTH (FEET) = 0.04
TRAVEL TIME (MIN.)	=	16.16 Tc (MIN.) = 20.52
LONGEST FLOWPATH FROM NODE	2400.00 TO NODE	2402.00 = 900.00 FEET.

FLOW PROCESS FROM NODE 2402.00 TO NODE 2403.00 IS CODE = 81

>>>>ADDITION OF SUBAREA TO MAINLINE PEAK FLOW<<<<<

=====

100 YEAR RAINFALL INTENSITY (INCH/HOUR)	=	2.014
STREETS & ROADS (DITCHES) RUNOFF COEFFICIENT	=	.7100
SOIL CLASSIFICATION IS	"D"	
S.C.S. CURVE NUMBER (AMC II)	=	93
AREA-AVERAGE RUNOFF COEFFICIENT	=	0.7100
SUBAREA AREA (ACRES)	=	67.70 SUBAREA RUNOFF (CFS) = 96.79
TOTAL AREA (ACRES)	=	67.80 TOTAL RUNOFF (CFS) = 96.94
TC (MIN.)	=	20.52

FLOW PROCESS FROM NODE 0.00 TO NODE 0.00 IS CODE = 13

>>>>CLEAR THE MAIN-STREAM MEMORY<<<<<

FLOW PROCESS FROM NODE 2500.00 TO NODE 2501.00 IS CODE = 21

>>>>RATIONAL METHOD INITIAL SUBAREA ANALYSIS<<<<<

=====

STREETS & ROADS (DITCHES) RUNOFF COEFFICIENT	=	.7100
SOIL CLASSIFICATION IS	"D"	
S.C.S. CURVE NUMBER (AMC II)	=	93
INITIAL SUBAREA FLOW-LENGTH (FEET)	=	70.00
UPSTREAM ELEVATION (FEET)	=	130.00
DOWNSTREAM ELEVATION (FEET)	=	128.25

ELEVATION DIFFERENCE (FEET) = 1.75
SUBAREA OVERLAND TIME OF FLOW (MIN.) = 4.328
100 YEAR RAINFALL INTENSITY (INCH/HOUR) = 5.006
NOTE: RAINFALL INTENSITY IS BASED ON Tc = 5-MINUTE.
SUBAREA RUNOFF (CFS) = 0.36
TOTAL AREA (ACRES) = 0.10 TOTAL RUNOFF (CFS) = 0.36

FLOW PROCESS FROM NODE 2501.00 TO NODE 2502.00 IS CODE = 51

>>>>COMPUTE TRAPEZOIDAL CHANNEL FLOW<<<<<
>>>>TRAVELTIME THRU SUBAREA (EXISTING ELEMENT) <<<<<

=====

CHANNEL LENGTH THRU SUBAREA (FEET) = 1130.00
REPRESENTATIVE CHANNEL SLOPE = 0.0250
CHANNEL BASE (FEET) = 10.00 "Z" FACTOR = 50.000
MANNING'S FACTOR = 0.030 MAXIMUM DEPTH (FEET) = 2.00
CHANNEL FLOW THRU SUBAREA (CFS) = 0.36
FLOW VELOCITY (FEET/SEC.) = 0.86 FLOW DEPTH (FEET) = 0.04
TRAVEL TIME (MIN.) = 22.00 Tc (MIN.) = 26.32
LONGEST FLOWPATH FROM NODE 2500.00 TO NODE 2502.00 = 1200.00 FEET.

FLOW PROCESS FROM NODE 2502.00 TO NODE 2503.00 IS CODE = 81

>>>>ADDITION OF SUBAREA TO MAINLINE PEAK FLOW<<<<<

=====

100 YEAR RAINFALL INTENSITY (INCH/HOUR) = 1.715
STREETS & ROADS (DITCHES) RUNOFF COEFFICIENT = .7100
SOIL CLASSIFICATION IS "D"
S.C.S. CURVE NUMBER (AMC II) = 93
AREA-AVERAGE RUNOFF COEFFICIENT = 0.7100
SUBAREA AREA (ACRES) = 40.70 SUBAREA RUNOFF (CFS) = 49.55
TOTAL AREA (ACRES) = 40.80 TOTAL RUNOFF (CFS) = 49.67
TC (MIN.) = 26.32

FLOW PROCESS FROM NODE 0.00 TO NODE 0.00 IS CODE = 13

>>>>CLEAR THE MAIN-STREAM MEMORY<<<<<

FLOW PROCESS FROM NODE 2600.00 TO NODE 2601.00 IS CODE = 21

>>>>RATIONAL METHOD INITIAL SUBAREA ANALYSIS<<<<<

=====

STREETS & ROADS (DITCHES) RUNOFF COEFFICIENT = .7100
SOIL CLASSIFICATION IS "D"
S.C.S. CURVE NUMBER (AMC II) = 93
INITIAL SUBAREA FLOW-LENGTH (FEET) = 70.00
UPSTREAM ELEVATION (FEET) = 130.00
DOWNSTREAM ELEVATION (FEET) = 128.25
ELEVATION DIFFERENCE (FEET) = 1.75
SUBAREA OVERLAND TIME OF FLOW (MIN.) = 4.328
100 YEAR RAINFALL INTENSITY (INCH/HOUR) = 5.006
NOTE: RAINFALL INTENSITY IS BASED ON Tc = 5-MINUTE.

SUBAREA RUNOFF(CFS) = 0.36
TOTAL AREA(ACRES) = 0.10 TOTAL RUNOFF(CFS) = 0.36

FLOW PROCESS FROM NODE 2601.00 TO NODE 2602.00 IS CODE = 51

>>>>COMPUTE TRAPEZOIDAL CHANNEL FLOW<<<<<
>>>>TRAVELTIME THRU SUBAREA (EXISTING ELEMENT)<<<<<

=====
CHANNEL LENGTH THRU SUBAREA(FEET) = 1130.00
REPRESENTATIVE CHANNEL SLOPE = 0.0250
CHANNEL BASE(FEET) = 10.00 "Z" FACTOR = 50.000
MANNING'S FACTOR = 0.030 MAXIMUM DEPTH(FEET) = 2.00
CHANNEL FLOW THRU SUBAREA(CFS) = 0.36
FLOW VELOCITY(FEET/SEC.) = 0.86 FLOW DEPTH(FEET) = 0.04
TRAVEL TIME(MIN.) = 22.00 Tc(MIN.) = 26.32
LONGEST FLOWPATH FROM NODE 2600.00 TO NODE 2602.00 = 1200.00 FEET.

FLOW PROCESS FROM NODE 2602.00 TO NODE 2603.00 IS CODE = 81

>>>>ADDITION OF SUBAREA TO MAINLINE PEAK FLOW<<<<<

=====
100 YEAR RAINFALL INTENSITY(INCH/HOUR) = 1.715
STREETS & ROADS (DITCHES) RUNOFF COEFFICIENT = .7100
SOIL CLASSIFICATION IS "D"
S.C.S. CURVE NUMBER (AMC II) = 93
AREA-AVERAGE RUNOFF COEFFICIENT = 0.7100
SUBAREA AREA(ACRES) = 34.70 SUBAREA RUNOFF(CFS) = 42.25
TOTAL AREA(ACRES) = 34.80 TOTAL RUNOFF(CFS) = 42.37
TC(MIN.) = 26.32

FLOW PROCESS FROM NODE 0.00 TO NODE 0.00 IS CODE = 13

>>>>CLEAR THE MAIN-STREAM MEMORY<<<<<

FLOW PROCESS FROM NODE 2700.00 TO NODE 2701.00 IS CODE = 21

>>>>RATIONAL METHOD INITIAL SUBAREA ANALYSIS<<<<<

=====
STREETS & ROADS (DITCHES) RUNOFF COEFFICIENT = .7100
SOIL CLASSIFICATION IS "D"
S.C.S. CURVE NUMBER (AMC II) = 93
INITIAL SUBAREA FLOW-LENGTH(FEET) = 70.00
UPSTREAM ELEVATION(FEET) = 105.00
DOWNSTREAM ELEVATION(FEET) = 103.25
ELEVATION DIFFERENCE(FEET) = 1.75
SUBAREA OVERLAND TIME OF FLOW(MIN.) = 4.328
100 YEAR RAINFALL INTENSITY(INCH/HOUR) = 5.006
NOTE: RAINFALL INTENSITY IS BASED ON Tc = 5-MINUTE.
SUBAREA RUNOFF(CFS) = 0.36
TOTAL AREA(ACRES) = 0.10 TOTAL RUNOFF(CFS) = 0.36

FLOW PROCESS FROM NODE 2701.00 TO NODE 2702.00 IS CODE = 51

>>>>COMPUTE TRAPEZOIDAL CHANNEL FLOW<<<<<
>>>>TRAVELTIME THRU SUBAREA (EXISTING ELEMENT)<<<<<

=====

CHANNEL LENGTH THRU SUBAREA (FEET) = 130.00
REPRESENTATIVE CHANNEL SLOPE = 0.0250
CHANNEL BASE (FEET) = 10.00 "Z" FACTOR = 50.000
MANNING'S FACTOR = 0.030 MAXIMUM DEPTH (FEET) = 2.00
CHANNEL FLOW THRU SUBAREA (CFS) = 0.36
FLOW VELOCITY (FEET/SEC.) = 0.86 FLOW DEPTH (FEET) = 0.04
TRAVEL TIME (MIN.) = 2.53 Tc (MIN.) = 6.86
LONGEST FLOWPATH FROM NODE 2700.00 TO NODE 2702.00 = 200.00 FEET.

FLOW PROCESS FROM NODE 2702.00 TO NODE 2703.00 IS CODE = 81

>>>>ADDITION OF SUBAREA TO MAINLINE PEAK FLOW<<<<<

=====

100 YEAR RAINFALL INTENSITY (INCH/HOUR) = 4.083
STREETS & ROADS (DITCHES) RUNOFF COEFFICIENT = .7100
SOIL CLASSIFICATION IS "D"
S.C.S. CURVE NUMBER (AMC II) = 93
AREA-AVERAGE RUNOFF COEFFICIENT = 0.7100
SUBAREA AREA (ACRES) = 14.80 SUBAREA RUNOFF (CFS) = 42.90
TOTAL AREA (ACRES) = 14.90 TOTAL RUNOFF (CFS) = 43.19
TC (MIN.) = 6.86

FLOW PROCESS FROM NODE 0.00 TO NODE 0.00 IS CODE = 13

>>>>CLEAR THE MAIN-STREAM MEMORY<<<<<

FLOW PROCESS FROM NODE 2800.00 TO NODE 2801.00 IS CODE = 21

>>>>RATIONAL METHOD INITIAL SUBAREA ANALYSIS<<<<<

=====

STREETS & ROADS (DITCHES) RUNOFF COEFFICIENT = .7100
SOIL CLASSIFICATION IS "D"
S.C.S. CURVE NUMBER (AMC II) = 93
INITIAL SUBAREA FLOW-LENGTH (FEET) = 70.00
UPSTREAM ELEVATION (FEET) = 128.00
DOWNSTREAM ELEVATION (FEET) = 26.22
ELEVATION DIFFERENCE (FEET) = 101.78
SUBAREA OVERLAND TIME OF FLOW (MIN.) = 2.726
WARNING: THE MAXIMUM OVERLAND FLOW SLOPE, 10.%, IS USED IN Tc CALCULATION!
100 YEAR RAINFALL INTENSITY (INCH/HOUR) = 5.006
NOTE: RAINFALL INTENSITY IS BASED ON Tc = 5-MINUTE.
SUBAREA RUNOFF (CFS) = 0.36
TOTAL AREA (ACRES) = 0.10 TOTAL RUNOFF (CFS) = 0.36

FLOW PROCESS FROM NODE 2801.00 TO NODE 2802.00 IS CODE = 51

>>>>COMPUTE TRAPEZOIDAL CHANNEL FLOW<<<<<

>>>>TRAVELTIME THRU SUBAREA (EXISTING ELEMENT)<<<<<

=====

CHANNEL LENGTH THRU SUBAREA (FEET) = 1030.00
REPRESENTATIVE CHANNEL SLOPE = 0.0250
CHANNEL BASE (FEET) = 10.00 "Z" FACTOR = 50.000
MANNING'S FACTOR = 0.030 MAXIMUM DEPTH (FEET) = 2.00
CHANNEL FLOW THRU SUBAREA (CFS) = 0.36
FLOW VELOCITY (FEET/SEC.) = 0.86 FLOW DEPTH (FEET) = 0.04
TRAVEL TIME (MIN.) = 20.05 Tc (MIN.) = 22.78
LONGEST FLOWPATH FROM NODE 2800.00 TO NODE 2802.00 = 1100.00 FEET.

FLOW PROCESS FROM NODE 2802.00 TO NODE 2803.00 IS CODE = 81

>>>>ADDITION OF SUBAREA TO MAINLINE PEAK FLOW<<<<<

=====

100 YEAR RAINFALL INTENSITY (INCH/HOUR) = 1.883
STREETS & ROADS (DITCHES) RUNOFF COEFFICIENT = .7100
SOIL CLASSIFICATION IS "D"
S.C.S. CURVE NUMBER (AMC II) = 93
AREA-AVERAGE RUNOFF COEFFICIENT = 0.7100
SUBAREA AREA (ACRES) = 81.20 SUBAREA RUNOFF (CFS) = 108.53
TOTAL AREA (ACRES) = 81.30 TOTAL RUNOFF (CFS) = 108.67
TC (MIN.) = 22.78

FLOW PROCESS FROM NODE 0.00 TO NODE 0.00 IS CODE = 13

>>>>CLEAR THE MAIN-STREAM MEMORY<<<<<

FLOW PROCESS FROM NODE 2900.00 TO NODE 2901.00 IS CODE = 21

>>>>RATIONAL METHOD INITIAL SUBAREA ANALYSIS<<<<<

=====

STREETS & ROADS (DITCHES) RUNOFF COEFFICIENT = .7100
SOIL CLASSIFICATION IS "D"
S.C.S. CURVE NUMBER (AMC II) = 93
INITIAL SUBAREA FLOW-LENGTH (FEET) = 70.00
UPSTREAM ELEVATION (FEET) = 118.00
DOWNSTREAM ELEVATION (FEET) = 116.20
ELEVATION DIFFERENCE (FEET) = 1.80
SUBAREA OVERLAND TIME OF FLOW (MIN.) = 4.287
100 YEAR RAINFALL INTENSITY (INCH/HOUR) = 5.006
NOTE: RAINFALL INTENSITY IS BASED ON Tc = 5-MINUTE.
SUBAREA RUNOFF (CFS) = 0.36
TOTAL AREA (ACRES) = 0.10 TOTAL RUNOFF (CFS) = 0.36

FLOW PROCESS FROM NODE 2901.00 TO NODE 2902.00 IS CODE = 51

>>>>COMPUTE TRAPEZOIDAL CHANNEL FLOW<<<<<

>>>>TRAVELTIME THRU SUBAREA (EXISTING ELEMENT)<<<<<

=====

CHANNEL LENGTH THRU SUBAREA (FEET) = 630.00
REPRESENTATIVE CHANNEL SLOPE = 0.0250

CHANNEL BASE (FEET) = 10.00 "Z" FACTOR = 50.000
MANNING'S FACTOR = 0.030 MAXIMUM DEPTH (FEET) = 2.00
CHANNEL FLOW THRU SUBAREA (CFS) = 0.36
FLOW VELOCITY (FEET/SEC.) = 0.86 FLOW DEPTH (FEET) = 0.04
TRAVEL TIME (MIN.) = 12.26 Tc (MIN.) = 16.55
LONGEST FLOWPATH FROM NODE 2900.00 TO NODE 2902.00 = 700.00 FEET.

FLOW PROCESS FROM NODE 2902.00 TO NODE 2903.00 IS CODE = 81

>>>>ADDITION OF SUBAREA TO MAINLINE PEAK FLOW<<<<<

=====

100 YEAR RAINFALL INTENSITY (INCH/HOUR) = 2.313
STREETS & ROADS (DITCHES) RUNOFF COEFFICIENT = .7100
SOIL CLASSIFICATION IS "D"
S.C.S. CURVE NUMBER (AMC II) = 93
AREA-AVERAGE RUNOFF COEFFICIENT = 0.7100
SUBAREA AREA (ACRES) = 36.80 SUBAREA RUNOFF (CFS) = 60.44
TOTAL AREA (ACRES) = 36.90 TOTAL RUNOFF (CFS) = 60.60
TC (MIN.) = 16.55

FLOW PROCESS FROM NODE 0.00 TO NODE 0.00 IS CODE = 13

>>>>CLEAR THE MAIN-STREAM MEMORY<<<<<

FLOW PROCESS FROM NODE 2910.00 TO NODE 2911.00 IS CODE = 21

>>>>RATIONAL METHOD INITIAL SUBAREA ANALYSIS<<<<<

=====

STREETS & ROADS (DITCHES) RUNOFF COEFFICIENT = .7100
SOIL CLASSIFICATION IS "D"
S.C.S. CURVE NUMBER (AMC II) = 93
INITIAL SUBAREA FLOW-LENGTH (FEET) = 70.00
UPSTREAM ELEVATION (FEET) = 108.00
DOWNSTREAM ELEVATION (FEET) = 106.25
ELEVATION DIFFERENCE (FEET) = 1.75
SUBAREA OVERLAND TIME OF FLOW (MIN.) = 4.328
100 YEAR RAINFALL INTENSITY (INCH/HOUR) = 5.006
NOTE: RAINFALL INTENSITY IS BASED ON Tc = 5-MINUTE.
SUBAREA RUNOFF (CFS) = 0.36
TOTAL AREA (ACRES) = 0.10 TOTAL RUNOFF (CFS) = 0.36

FLOW PROCESS FROM NODE 2911.00 TO NODE 2912.00 IS CODE = 51

>>>>COMPUTE TRAPEZOIDAL CHANNEL FLOW<<<<<
>>>>TRAVELTIME THRU SUBAREA (EXISTING ELEMENT)<<<<<

=====

CHANNEL LENGTH THRU SUBAREA (FEET) = 230.00
REPRESENTATIVE CHANNEL SLOPE = 0.0250
CHANNEL BASE (FEET) = 10.00 "Z" FACTOR = 50.000
MANNING'S FACTOR = 0.030 MAXIMUM DEPTH (FEET) = 2.00
CHANNEL FLOW THRU SUBAREA (CFS) = 0.36
FLOW VELOCITY (FEET/SEC.) = 0.86 FLOW DEPTH (FEET) = 0.04

TRAVEL TIME(MIN.) = 4.48 Tc(MIN.) = 8.80
LONGEST FLOWPATH FROM NODE 2910.00 TO NODE 2912.00 = 300.00 FEET.

FLOW PROCESS FROM NODE 2912.00 TO NODE 2913.00 IS CODE = 81

>>>>ADDITION OF SUBAREA TO MAINLINE PEAK FLOW<<<<<

=====

100 YEAR RAINFALL INTENSITY(INCH/HOUR)	=	3.475
STREETS & ROADS (DITCHES) RUNOFF COEFFICIENT	=	.7100
SOIL CLASSIFICATION IS	"D"	
S.C.S. CURVE NUMBER (AMC II)	=	93
AREA-AVERAGE RUNOFF COEFFICIENT	=	0.7100
SUBAREA AREA(ACRES)	=	12.80
SUBAREA RUNOFF(CFS)	=	31.58
TOTAL AREA(ACRES)	=	12.90
TOTAL RUNOFF(CFS)	=	31.83
TC(MIN.)	=	8.80

FLOW PROCESS FROM NODE 0.00 TO NODE 0.00 IS CODE = 13

>>>>CLEAR THE MAIN-STREAM MEMORY<<<<<

FLOW PROCESS FROM NODE 2100.00 TO NODE 2101.00 IS CODE = 21

>>>>RATIONAL METHOD INITIAL SUBAREA ANALYSIS<<<<<

=====

STREETS & ROADS (DITCHES) RUNOFF COEFFICIENT	=	.7100
SOIL CLASSIFICATION IS	"D"	
S.C.S. CURVE NUMBER (AMC II)	=	93
INITIAL SUBAREA FLOW-LENGTH(FEET)	=	70.00
UPSTREAM ELEVATION(FEET)	=	160.00
DOWNSTREAM ELEVATION(FEET)	=	158.25
ELEVATION DIFFERENCE(FEET)	=	1.75
SUBAREA OVERLAND TIME OF FLOW(MIN.)	=	4.328
100 YEAR RAINFALL INTENSITY(INCH/HOUR)	=	5.006
NOTE: RAINFALL INTENSITY IS BASED ON Tc = 5-MINUTE.		
SUBAREA RUNOFF(CFS)	=	0.36
TOTAL AREA(ACRES)	=	0.10
TOTAL RUNOFF(CFS)	=	0.36

FLOW PROCESS FROM NODE 2101.00 TO NODE 2102.00 IS CODE = 51

>>>>COMPUTE TRAPEZOIDAL CHANNEL FLOW<<<<<
>>>>TRAVELTIME THRU SUBAREA (EXISTING ELEMENT)<<<<<

=====

CHANNEL LENGTH THRU SUBAREA(FEET)	=	2330.00
REPRESENTATIVE CHANNEL SLOPE	=	0.0250
CHANNEL BASE(FEET)	=	10.00
"Z" FACTOR	=	50.000
MANNING'S FACTOR	=	0.030
MAXIMUM DEPTH(FEET)	=	2.00
CHANNEL FLOW THRU SUBAREA(CFS)	=	0.36
FLOW VELOCITY(FEET/SEC.)	=	0.86
FLOW DEPTH(FEET)	=	0.04
TRAVEL TIME(MIN.)	=	45.35
Tc(MIN.)	=	49.68
LONGEST FLOWPATH FROM NODE 2100.00 TO NODE 2102.00	=	2400.00 FEET.

FLOW PROCESS FROM NODE 2102.00 TO NODE 2103.00 IS CODE = 81

>>>>ADDITION OF SUBAREA TO MAINLINE PEAK FLOW<<<<<

=====

100 YEAR RAINFALL INTENSITY(INCH/HOUR) = 1.138
STREETS & ROADS (DITCHES) RUNOFF COEFFICIENT = .7100
SOIL CLASSIFICATION IS "D"
S.C.S. CURVE NUMBER (AMC II) = 93
AREA-AVERAGE RUNOFF COEFFICIENT = 0.7100
SUBAREA AREA(ACRES) = 128.30 SUBAREA RUNOFF(CFS) = 103.70
TOTAL AREA(ACRES) = 128.40 TOTAL RUNOFF(CFS) = 103.78
TC(MIN.) = 49.68

FLOW PROCESS FROM NODE 0.00 TO NODE 0.00 IS CODE = 13

>>>>CLEAR THE MAIN-STREAM MEMORY<<<<<

FLOW PROCESS FROM NODE 2110.00 TO NODE 2111.00 IS CODE = 21

>>>>RATIONAL METHOD INITIAL SUBAREA ANALYSIS<<<<<

=====

STREETS & ROADS (DITCHES) RUNOFF COEFFICIENT = .7100
SOIL CLASSIFICATION IS "D"
S.C.S. CURVE NUMBER (AMC II) = 93
INITIAL SUBAREA FLOW-LENGTH(FEET) = 70.00
UPSTREAM ELEVATION(FEET) = 143.00
DOWNSTREAM ELEVATION(FEET) = 141.25
ELEVATION DIFFERENCE(FEET) = 1.75
SUBAREA OVERLAND TIME OF FLOW(MIN.) = 4.328
100 YEAR RAINFALL INTENSITY(INCH/HOUR) = 5.006
NOTE: RAINFALL INTENSITY IS BASED ON Tc = 5-MINUTE.
SUBAREA RUNOFF(CFS) = 0.36
TOTAL AREA(ACRES) = 0.10 TOTAL RUNOFF(CFS) = 0.36

FLOW PROCESS FROM NODE 2111.00 TO NODE 2112.00 IS CODE = 51

>>>>COMPUTE TRAPEZOIDAL CHANNEL FLOW<<<<<
>>>>TRAVELTIME THRU SUBAREA (EXISTING ELEMENT)<<<<<

=====

CHANNEL LENGTH THRU SUBAREA(FEET) = 1630.00
REPRESENTATIVE CHANNEL SLOPE = 0.0250
CHANNEL BASE(FEET) = 10.00 "Z" FACTOR = 50.000
MANNING'S FACTOR = 0.030 MAXIMUM DEPTH(FEET) = 2.00
CHANNEL FLOW THRU SUBAREA(CFS) = 0.36
FLOW VELOCITY(FEET/SEC.) = 0.86 FLOW DEPTH(FEET) = 0.04
TRAVEL TIME(MIN.) = 31.73 Tc(MIN.) = 36.06
LONGEST FLOWPATH FROM NODE 2110.00 TO NODE 2112.00 = 1700.00 FEET.

FLOW PROCESS FROM NODE 2112.00 TO NODE 2113.00 IS CODE = 81

>>>>ADDITION OF SUBAREA TO MAINLINE PEAK FLOW<<<<<

100 YEAR RAINFALL INTENSITY(INCH/HOUR) = 1.400
STREETS & ROADS (DITCHES) RUNOFF COEFFICIENT = .7100
SOIL CLASSIFICATION IS "D"
S.C.S. CURVE NUMBER (AMC II) = 93
AREA-AVERAGE RUNOFF COEFFICIENT = 0.7100
SUBAREA AREA(ACRES) = 275.50 SUBAREA RUNOFF(CFS) = 273.81
TOTAL AREA(ACRES) = 275.60 TOTAL RUNOFF(CFS) = 273.91
TC(MIN.) = 36.06

FLOW PROCESS FROM NODE 0:00 TO NODE 0.00 IS CODE = 13

>>>>CLEAR THE MAIN-STREAM MEMORY<<<<<

FLOW PROCESS FROM NODE 2120.00 TO NODE 2121.00 IS CODE = 21

>>>>RATIONAL METHOD INITIAL SUBAREA ANALYSIS<<<<<

STREETS & ROADS (DITCHES) RUNOFF COEFFICIENT = .7100
SOIL CLASSIFICATION IS "D"
S.C.S. CURVE NUMBER (AMC II) = 93
INITIAL SUBAREA FLOW-LENGTH(FEET) = 70.00
UPSTREAM ELEVATION(FEET) = 113.00
DOWNSTREAM ELEVATION(FEET) = 111.25
ELEVATION DIFFERENCE(FEET) = 1.75
SUBAREA OVERLAND TIME OF FLOW(MIN.) = 4.328
100 YEAR RAINFALL INTENSITY(INCH/HOUR) = 5.006
NOTE: RAINFALL INTENSITY IS BASED ON Tc = 5-MINUTE.
SUBAREA RUNOFF(CFS) = 0.36
TOTAL AREA(ACRES) = 0.10 TOTAL RUNOFF(CFS) = 0.36

FLOW PROCESS FROM NODE 2121.00 TO NODE 2122.00 IS CODE = 51

>>>>COMPUTE TRAPEZOIDAL CHANNEL FLOW<<<<<
>>>>TRAVELTIME THRU SUBAREA (EXISTING ELEMENT)<<<<<

CHANNEL LENGTH THRU SUBAREA(FEET) = 430.00
REPRESENTATIVE CHANNEL SLOPE = 0.0250
CHANNEL BASE(FEET) = 10.00 "Z" FACTOR = 50.000
MANNING'S FACTOR = 0.030 MAXIMUM DEPTH(FEET) = 2.00
CHANNEL FLOW THRU SUBAREA(CFS) = 0.36
FLOW VELOCITY(FEET/SEC.) = 0.86 FLOW DEPTH(FEET) = 0.04
TRAVEL TIME(MIN.) = 8.37 Tc(MIN.) = 12.70
LONGEST FLOWPATH FROM NODE 2120.00 TO NODE 2122.00 = 500.00 FEET.

FLOW PROCESS FROM NODE 2122.00 TO NODE 2123.00 IS CODE = 81

>>>>ADDITION OF SUBAREA TO MAINLINE PEAK FLOW<<<<<

100 YEAR RAINFALL INTENSITY(INCH/HOUR) = 2.744
STREETS & ROADS (DITCHES) RUNOFF COEFFICIENT = .7100
SOIL CLASSIFICATION IS "D"
S.C.S. CURVE NUMBER (AMC II) = 93

AREA-AVERAGE RUNOFF COEFFICIENT = 0.7100
SUBAREA AREA (ACRES) = 23.50 SUBAREA RUNOFF (CFS) = 45.79
TOTAL AREA (ACRES) = 23.60 TOTAL RUNOFF (CFS) = 45.98
TC (MIN.) = 12.70

FLOW PROCESS FROM NODE 0.00 TO NODE 0.00 IS CODE = 13

>>>>CLEAR THE MAIN-STREAM MEMORY<<<<<

FLOW PROCESS FROM NODE 2130.00 TO NODE 2131.00 IS CODE = 21

>>>>RATIONAL METHOD INITIAL SUBAREA ANALYSIS<<<<<

STREETS & ROADS (DITCHES) RUNOFF COEFFICIENT = .7100
SOIL CLASSIFICATION IS "D"
S.C.S. CURVE NUMBER (AMC II) = 93
INITIAL SUBAREA FLOW-LENGTH (FEET) = 70.00
UPSTREAM ELEVATION (FEET) = 115.00
DOWNSTREAM ELEVATION (FEET) = 113.25
ELEVATION DIFFERENCE (FEET) = 1.75
SUBAREA OVERLAND TIME OF FLOW (MIN.) = 4.328
100 YEAR RAINFALL INTENSITY (INCH/HOUR) = 5.006
NOTE: RAINFALL INTENSITY IS BASED ON Tc = 5-MINUTE.
SUBAREA RUNOFF (CFS) = 0.36
TOTAL AREA (ACRES) = 0.10 TOTAL RUNOFF (CFS) = 0.36

FLOW PROCESS FROM NODE 2131.00 TO NODE 2132.00 IS CODE = 51

>>>>COMPUTE TRAPEZOIDAL CHANNEL FLOW<<<<<
>>>>TRAVELTIME THRU SUBAREA (EXISTING ELEMENT) <<<<<

CHANNEL LENGTH THRU SUBAREA (FEET) = 530.00
REPRESENTATIVE CHANNEL SLOPE = 0.0250
CHANNEL BASE (FEET) = 10.00 "Z" FACTOR = 50.000
MANNING'S FACTOR = 0.030 MAXIMUM DEPTH (FEET) = 2.00
CHANNEL FLOW THRU SUBAREA (CFS) = 0.36
FLOW VELOCITY (FEET/SEC.) = 0.86 FLOW DEPTH (FEET) = 0.04
TRAVEL TIME (MIN.) = 10.32 Tc (MIN.) = 14.64
LONGEST FLOWPATH FROM NODE 2130.00 TO NODE 2132.00 = 600.00 FEET.

FLOW PROCESS FROM NODE 2132.00 TO NODE 2133.00 IS CODE = 81

>>>>ADDITION OF SUBAREA TO MAINLINE PEAK FLOW<<<<<

100 YEAR RAINFALL INTENSITY (INCH/HOUR) = 2.503
STREETS & ROADS (DITCHES) RUNOFF COEFFICIENT = .7100
SOIL CLASSIFICATION IS "D"
S.C.S. CURVE NUMBER (AMC II) = 93
AREA-AVERAGE RUNOFF COEFFICIENT = 0.7100
SUBAREA AREA (ACRES) = 61.40 SUBAREA RUNOFF (CFS) = 109.12
TOTAL AREA (ACRES) = 61.50 TOTAL RUNOFF (CFS) = 109.30
TC (MIN.) = 14.64

FLOW PROCESS FROM NODE 0.00 TO NODE 0.00 IS CODE = 13

>>>>CLEAR THE MAIN-STREAM MEMORY<<<<<

FLOW PROCESS FROM NODE 2140.00 TO NODE 2141.00 IS CODE = 21

>>>>RATIONAL METHOD INITIAL SUBAREA ANALYSIS<<<<<

STREETS & ROADS (DITCHES) RUNOFF COEFFICIENT = .7100
SOIL CLASSIFICATION IS "D"
S.C.S. CURVE NUMBER (AMC II) = 93
INITIAL SUBAREA FLOW-LENGTH (FEET) = 70.00
UPSTREAM ELEVATION (FEET) = 125.00
DOWNSTREAM ELEVATION (FEET) = 123.25
ELEVATION DIFFERENCE (FEET) = 1.75
SUBAREA OVERLAND TIME OF FLOW (MIN.) = 4.328
100 YEAR RAINFALL INTENSITY (INCH/HOUR) = 5.006
NOTE: RAINFALL INTENSITY IS BASED ON Tc = 5-MINUTE.
SUBAREA RUNOFF (CFS) = 0.36
TOTAL AREA (ACRES) = 0.10 TOTAL RUNOFF (CFS) = 0.36

FLOW PROCESS FROM NODE 2141.00 TO NODE 2142.00 IS CODE = 51

>>>>COMPUTE TRAPEZOIDAL CHANNEL FLOW<<<<<
>>>>TRAVELTIME THRU SUBAREA (EXISTING ELEMENT)<<<<<

CHANNEL LENGTH THRU SUBAREA (FEET) = 930.00
REPRESENTATIVE CHANNEL SLOPE = 0.0250
CHANNEL BASE (FEET) = 10.00 "Z" FACTOR = 50.000
MANNING'S FACTOR = 0.030 MAXIMUM DEPTH (FEET) = 2.00
CHANNEL FLOW THRU SUBAREA (CFS) = 0.36
FLOW VELOCITY (FEET/SEC.) = 0.86 FLOW DEPTH (FEET) = 0.04
TRAVEL TIME (MIN.) = 18.10 Tc (MIN.) = 22.43
LONGEST FLOWPATH FROM NODE 2140.00 TO NODE 2142.00 = 1000.00 FEET.

FLOW PROCESS FROM NODE 2142.00 TO NODE 2143.00 IS CODE = 81

>>>>ADDITION OF SUBAREA TO MAINLINE PEAK FLOW<<<<<

100 YEAR RAINFALL INTENSITY (INCH/HOUR) = 1.901
STREETS & ROADS (DITCHES) RUNOFF COEFFICIENT = .7100
SOIL CLASSIFICATION IS "D"
S.C.S. CURVE NUMBER (AMC II) = 93
AREA-AVERAGE RUNOFF COEFFICIENT = 0.7100
SUBAREA AREA (ACRES) = 48.30 SUBAREA RUNOFF (CFS) = 65.20
TOTAL AREA (ACRES) = 48.40 TOTAL RUNOFF (CFS) = 65.33
TC (MIN.) = 22.43

FLOW PROCESS FROM NODE 0.00 TO NODE 0.00 IS CODE = 13

FLOW PROCESS FROM NODE 2160.00 TO NODE 2161.00 IS CODE = 21

>>>>RATIONAL METHOD INITIAL SUBAREA ANALYSIS<<<<<

STREETS & ROADS (DITCHES) RUNOFF COEFFICIENT = .7100
SOIL CLASSIFICATION IS "D"
S.C.S. CURVE NUMBER (AMC II) = 93
INITIAL SUBAREA FLOW-LENGTH(FEET) = 70.00
UPSTREAM ELEVATION(FEET) = 160.00
DOWNSTREAM ELEVATION(FEET) = 158.25
ELEVATION DIFFERENCE(FEET) = 1.75
SUBAREA OVERLAND TIME OF FLOW(MIN.) = 4.328
100 YEAR RAINFALL INTENSITY(INCH/HOUR) = 5.006
NOTE: RAINFALL INTENSITY IS BASED ON Tc = 5-MINUTE.
SUBAREA RUNOFF(CFS) = 0.36
TOTAL AREA(ACRES) = 0.10 TOTAL RUNOFF(CFS) = 0.36

FLOW PROCESS FROM NODE 2161.00 TO NODE 2162.00 IS CODE = 51

>>>>COMPUTE TRAPEZOIDAL CHANNEL FLOW<<<<<
>>>>TRAVELTIME THRU SUBAREA (EXISTING ELEMENT)<<<<<

CHANNEL LENGTH THRU SUBAREA(FEET) = 2330.00
REPRESENTATIVE CHANNEL SLOPE = 0.0250
CHANNEL BASE(FEET):= 10.00 "Z" FACTOR = 50.000
MANNING'S FACTOR = 0.030 MAXIMUM DEPTH(FEET) = 2.00
CHANNEL FLOW THRU SUBAREA(CFS) = 0.36
FLOW VELOCITY(FEET/SEC.) = 0.86 FLOW DEPTH(FEET) = 0.04
TRAVEL TIME(MIN.) = 45.35 Tc(MIN.) = 49.68
LONGEST FLOWPATH FROM NODE 2160.00 TO NODE 2162.00 = 2400.00 FEET.

FLOW PROCESS FROM NODE 2162.00 TO NODE 2163.00 IS CODE = 81

>>>>ADDITION OF SUBAREA TO MAINLINE PEAK FLOW<<<<<

100 YEAR RAINFALL INTENSITY(INCH/HOUR) = 1.138
STREETS & ROADS (DITCHES) RUNOFF COEFFICIENT = .7100
SOIL CLASSIFICATION IS "D"
S.C.S. CURVE NUMBER (AMC II) = 93
AREA-AVERAGE RUNOFF COEFFICIENT = 0.7100
SUBAREA AREA(ACRES) = 121.60 SUBAREA RUNOFF(CFS) = 98.28
TOTAL AREA(ACRES) = 121.70 TOTAL RUNOFF(CFS) = 98.36
TC(MIN.) = 49.68

FLOW PROCESS FROM NODE 0.00 TO NODE 0.00 IS CODE = 13

>>>>CLEAR THE MAIN-STREAM MEMORY<<<<<

FLOW PROCESS FROM NODE 2170.00 TO NODE 2171.00 IS CODE = 21

>>>>RATIONAL METHOD INITIAL SUBAREA ANALYSIS<<<<<

STREETS & ROADS (DITCHES) RUNOFF COEFFICIENT = .7100
SOIL CLASSIFICATION IS "D"
S.C.S. CURVE NUMBER (AMC II) = 93
INITIAL SUBAREA FLOW-LENGTH(FEET) = 70.00
UPSTREAM ELEVATION(FEET) = 175.00
DOWNSTREAM ELEVATION(FEET) = 173.25
ELEVATION DIFFERENCE(FEET) = 1.75
SUBAREA OVERLAND TIME OF FLOW(MIN.) = 4.328
100 YEAR RAINFALL INTENSITY(INCH/HOUR) = 5.006
NOTE: RAINFALL INTENSITY IS BASED ON Tc = 5-MINUTE.
SUBAREA RUNOFF(CFS) = 0.36
TOTAL AREA(ACRES) = 0.10 TOTAL RUNOFF(CFS) = 0.36

FLOW PROCESS FROM NODE 2171.00 TO NODE 2172.00 IS CODE = 51

>>>>COMPUTE TRAPEZOIDAL CHANNEL FLOW<<<<<
>>>>TRAVELTIME THRU SUBAREA (EXISTING ELEMENT)<<<<<

=====

CHANNEL LENGTH THRU SUBAREA(FEET)	=	2930.00
REPRESENTATIVE CHANNEL SLOPE	=	0.0250
CHANNEL BASE(FEET)	=	10.00
"Z" FACTOR	=	50.000
MANNING'S FACTOR	=	0.030
MAXIMUM DEPTH(FEET)	=	2.00
CHANNEL FLOW THRU SUBAREA(CFS)	=	0.36
FLOW VELOCITY(FEET/SEC.)	=	0.86
FLOW DEPTH(FEET)	=	0.04
TRAVEL TIME(MIN.)	=	57.03
Tc(MIN.)	=	61.36
LONGEST FLOWPATH FROM NODE 2170.00 TO NODE 2172.00	=	3000.00 FEET.

FLOW PROCESS FROM NODE 2172.00 TO NODE 2173.00 IS CODE = 81

>>>>ADDITION OF SUBAREA TO MAINLINE PEAK FLOW<<<<<

=====

100 YEAR RAINFALL INTENSITY(INCH/HOUR)	=	0.993
STREETS & ROADS (DITCHES) RUNOFF COEFFICIENT	=	.7100
SOIL CLASSIFICATION IS	=	"D"
S.C.S. CURVE NUMBER (AMC II)	=	93
AREA-AVERAGE RUNOFF COEFFICIENT	=	0.7100
SUBAREA AREA(ACRES)	=	60.20
SUBAREA RUNOFF(CFS)	=	42.46
TOTAL AREA(ACRES)	=	60.30
TOTAL RUNOFF(CFS)	=	42.53
TC(MIN.)	=	61.36

FLOW PROCESS FROM NODE 0.00 TO NODE 0.00 IS CODE = 13

>>>>CLEAR THE MAIN-STREAM MEMORY<<<<<

FLOW PROCESS FROM NODE 9990.00 TO NODE 9991.00 IS CODE = 21

>>>>RATIONAL METHOD INITIAL SUBAREA ANALYSIS<<<<<

=====

STREETS & ROADS (DITCHES) RUNOFF COEFFICIENT	=	.7100
SOIL CLASSIFICATION IS	=	"D"
S.C.S. CURVE NUMBER (AMC II)	=	93
INITIAL SUBAREA FLOW-LENGTH(FEET)	=	70.00

UPSTREAM ELEVATION (FEET) = 1300.00
DOWNSTREAM ELEVATION (FEET) = 1298.25
ELEVATION DIFFERENCE (FEET) = 1.75
SUBAREA OVERLAND TIME OF FLOW (MIN.) = 4.328
100 YEAR RAINFALL INTENSITY (INCH/HOUR) = 5.006
NOTE: RAINFALL INTENSITY IS BASED ON Tc = 5-MINUTE.
SUBAREA RUNOFF (CFS) = 0.36
TOTAL AREA (ACRES) = 0.10 TOTAL RUNOFF (CFS) = 0.36

FLOW PROCESS FROM NODE 9991.00 TO NODE 9992.00 IS CODE = 51

>>>>COMPUTE TRAPEZOIDAL CHANNEL FLOW<<<<<
>>>>TRAVELTIME THRU SUBAREA (EXISTING ELEMENT)<<<<<

=====

CHANNEL LENGTH THRU SUBAREA (FEET)	=	9930.00
REPRESENTATIVE CHANNEL SLOPE	=	0.0300
CHANNEL BASE (FEET)	=	10.00 "Z" FACTOR = 50.000
MANNING'S FACTOR	=	0.030 MAXIMUM DEPTH (FEET) = 2.00
CHANNEL FLOW THRU SUBAREA (CFS)	=	0.36
FLOW VELOCITY (FEET/SEC.)	=	0.86 FLOW DEPTH (FEET) = 0.04
TRAVEL TIME (MIN.)	=	193.29 Tc (MIN.) = 197.62
LONGEST FLOWPATH FROM NODE	9990.00 TO NODE	9992.00 = 10000.00 FEET.

FLOW PROCESS FROM NODE 9992.00 TO NODE 9993.00 IS CODE = 81

>>>>ADDITION OF SUBAREA TO MAINLINE PEAK FLOW<<<<<

=====

100 YEAR RAINFALL INTENSITY (INCH/HOUR)	=	0.467
STREETS & ROADS (DITCHES) RUNOFF COEFFICIENT	=	.7100
SOIL CLASSIFICATION IS	"D"	
S.C.S. CURVE NUMBER (AMC II)	=	93
AREA-AVERAGE RUNOFF COEFFICIENT	=	0.7100
SUBAREA AREA (ACRES)	=	774.70 SUBAREA RUNOFF (CFS) = 256.98
TOTAL AREA (ACRES)	=	774.80 TOTAL RUNOFF (CFS) = 257.02
TC (MIN.)	=	197.62

END OF STUDY SUMMARY:

TOTAL AREA (ACRES)	=	774.80	TC (MIN.) =	197.62
PEAK FLOW RATE (CFS)	=	257.02		

END OF RATIONAL METHOD ANALYSIS

Appendix B

- HEC-1 Model

```

*****
*****
* FLOOD HYDROGRAPH PACKAGE (HEC-1) *
ENGINEERS * JUN 1998 *
CENTER * *
* VERSION 4.1 *
STREET * *
95616 *
* RUN DATE 21DEC04 TIME 07:23:00 *
* *
*****

```

```

* U.S. ARMY CORPS OF
* HYDROLOGIC ENGINEERING
* 509 SECOND
* DAVIS, CALIFORNIA
* (916) 756-1104
*

```

```

X X XXXXXXX XXXXX X
X X X X X XX
X X X X X X
XXXXXXXX XXXX X XXXXX X
X X X X X X
X X X X X X
X X XXXXXXX XXXXX XXX

```

THIS PROGRAM REPLACES ALL PREVIOUS VERSIONS OF HEC-1 KNOWN AS HEC1 (JAN 73), HEC1GS, HEC1DB, AND HEC1KW. THE DEFINITIONS OF VARIABLES -RTIME- AND -RTIOR- HAVE CHANGED FROM THOSE USED WITH THE 1973-STYLE INPUT STRUCTURE. THE DEFINITION OF -AMSKK- ON RM-CARD WAS CHANGED WITH REVISIONS DATED 28 SEP 81. THIS IS THE FORTRAN77 VERSION.

NEW OPTIONS: DAMBREAK OUTFLOW SUBMERGENCE, SINGLE EVENT DAMAGE CALCULATION, DSS:WRITE STAGE FREQUENCY, DSS:READ TIME SERIES AT DESIRED CALCULATION INTERVAL, LOSS RATE:GREEN AND AMPT INFILTRATION, KINEMATIC WAVE: NEW FINITE DIFFERENCE ALGORITHM

PAGE 1

```

1
-----
HEC-1 INPUT
MINE ID.....1.....2.....3.....4.....5.....6.....7.....8.....9.....10
*DIAGRAM
1 ID .....1.....2.....3.....4.....5.....6.....7.....8.....9.....10
2 ID
3 ID
4 ID OTAY MESA HYDROLOGY
5 ID
6 ID
7 ID KIMLEY-HORN AND ASSOCIATES, INC.
8 ID 100 YEAR, 6 HOUR STORM EVENT
9 ID FILE: IN'9300WDB-SD-IN2.TXT OUT 9300WDB-015
10 ID LSM 8-31-98, MODIFIED 7-27-99 BY SLM
11 ID
12 IT 2 300
13 IO 0
14 KK A1 RUNOFF HYDROGRAPH
15 BA 0.075
16 PB 2.95
17 PI 0.0024 0.0024 0.0024 0.0024 0.0024 0.0024 0.0024 0.0024 0.0024 0.0024
18 PI 0.0024 0.0024 0.0024 0.0024 0.0024 0.0031 0.0031 0.0031 0.0031 0.0031
19 PI 0.0031 0.0031 0.0031 0.0031 0.0031 0.0031 0.0031 0.0031 0.0031 0.0031
20 PI 0.0037 0.0037 0.0037 0.0037 0.0037 0.0037 0.0037 0.0037 0.0037 0.0037
21 PI 0.0037 0.0037 0.0037 0.0037 0.0037 0.0047 0.0047 0.0047 0.0053 0.0053
22 PI 0.0053 0.0057 0.0057 0.0057 0.0057 0.0067 0.0067 0.0067 0.0083 0.0083
23 PI 0.0150 0.0180 0.0270 0.0380 0.0440 0.0420 0.0360 0.0280 0.0220 0.0220
24 PI 0.0200 0.0180 0.0160 0.0140 0.0110 0.0083 0.0083 0.0083 0.0077 0.0077
25 PI 0.0077 0.0073 0.0073 0.0073 0.0067 0.0067 0.0067 0.0053 0.0053 0.0053
26 PI 0.0048 0.0048 0.0048 0.0048 0.0048 0.0048 0.0048 0.0048 0.0048 0.0048
27 PI 0.0048 0.0048 0.0048 0.0048 0.0048 0.0038 0.0038 0.0038 0.0038 0.0038
28 PI 0.0038 0.0038 0.0038 0.0038 0.0038 0.0038 0.0038 0.0038 0.0038 0.0038
29 PI 0.0032 0.0032 0.0032 0.0032 0.0032 0.0032 0.0032 0.0032 0.0032 0.0032
30 PI 0.0032 0.0032 0.0032 0.0032 0.0032 0.0028 0.0028 0.0028 0.0028 0.0028
31 PI 0.0028 0.0028 0.0028 0.0028 0.0028 0.0028 0.0028 0.0028 0.0028 0.0028
32 PI 0.0025 0.0025 0.0025 0.0025 0.0025 0.0025 0.0025 0.0025 0.0025 0.0025
33 PI 0.0025 0.0025 0.0025 0.0025 0.0025 0.0025 0.0025 0.0025 0.0025 0.0025
34 PI 0.0024 0.0024 0.0024 0.0024 0.0024 0.0024 0.0024 0.0024 0.0024 0.0024
35 LS 83.9
36 UD 0.140
37 KK A7 RUNOFF HYDROGRAPH
38 BA 0.033
39 PE 2.90
40 LS 88.8
41 UD 0.062
42 KK 01 RUNOFF HYDROGRAPH
43 BA 0.228
44 PE 2.90
45 LS 81.5
46 UD 0.262

```

PAGE 2

LINE	ID	1	2	3	4	5	6	7	8	9	10
47	KK	CP-01	COMBINE HYDROGRAPHS FROM A1, A7, AND 01								
48	HC	3									
49	KK	CP-A15	ROUTE FROM CP 01								
50	RK	1800	0.009	0.20		TRAP	100	20			
51	KK	A5	RUNOFF HYDROGRAPH								
52	BA	0.062									
53	PE	3.00									
54	LS		83.9								
55	UD	0.062									
56	KK	CP-A10	ROUTE FROM A5								
57	RK	1320	0.003	0.013		TRAP	35	0			
58	KK	A10	RUNOFF HYDROGRAPH								
59	BA	0.082									
60	PE	2.90									
61	LS		88.8								
62	UD	0.042									
63	KK	CP-A10	COMBINE HYDROGRAPHS FROM A5 AND A10								
64	HC	2									
65	KK	CP-A15	ROUTE FROM CP A10								
66	RK	1320	0.011	0.017		TRAP	50	20			
67	KK	A15	RUNOFF HYDROGRAPH								
68	BA	0.098									
69	PE	2.80									
70	LS		89.9								
71	UD	0.087									
72	KK	CP-A15	COMBINE HYDROGRAPHS FROM CP-01, CP-A10, AND A15								
73	HC	3									
74	KK	CP-A20	ROUTE FROM CP-A15								
75	RK	3400	0.006	0.020		TRAP	200	20			
76	KK	05	RUNOFF HYDROGRAPH FROM 05								
77	BA	0.097									
78	PE	2.75									
79	LS		83.9								
80	UD	0.080									
81	KK	CP-A20	ROUTE FROM 05								
82	RK	3500	0.006	0.020		TRAP	200	20			
83	KK	A20	RUNOFF HYDROGRAPH								
84	BA	0.254									
85	PE	2.75									
86	LS		88.4								
87	UD	0.184									

HRC-1 INPUT

PAGE 5

LINE	ID	1	2	3	4	5	6	7	8	9	10
88	KK	A25	RUNOFF FROM A25								
89	BA	0.030									
90	PE	2.60									
91	LS		88.4								
92	UD	0.076									
93	KK	A27	RUNOFF HYDROGRAPH								
94	BA	0.021									
95	PE	2.60									
96	LS		93.8								
97	UD	0.041									
98	KK	CP-A20	COMBINE HYDROGRAPHS FROM CP-A15, 05, A25, A27, AND A20								
99	HC	5									
100	KE	CP-A25	ROUTE FROM CP-A20								
101	RK	1200	0.005	0.02		TRAP	20	2			
102	KE	A23	RUNOFF HYDROGRAPH FROM A23								
103	BA	0.051									
104	PE	2.60									
105	LS		93.8								
106	UD	0.058									
107	KK	CP-A25	ROUTE FROM A23								
108	RK	525	0.005	0.013		CIRC	3.5				
109	KK	CP-A25	COMBINE HYDROGRAPHS FROM A23, CP-A20								
110	HC	2									
111	KK	CP-A30	ROUTE FROM CP-A25								
112	RK	1100	0.005	0.020		TRAP	20	2			
113	KK	025	RUNOFF HYDROGRAPH								
114	BA	0.134									
115	PE	2.60									
116	LS		83.9								
117	UD	0.228									
118	KK	020	RUNOFF HYDROGRAPH								

119 BA 0.263
 120 PB 2.70
 121 LS 83.9
 122 UD 0.294

123 KK CP-030 ROUTE FROM 020
 124 RK 900 0.001 0.020 TRAP 200 20

125 KK 030 RUNOFF HYDROGRAPH
 126 BA 0.129
 127 PB 2.50
 128 LS 83.9
 129 UD 0.258

HEC-1 INPUT

LINE ID.....1.....2.....3.....4.....5.....6.....7.....8.....9.....10

130 KK CP-030 COMBINE HYDROGRAPHS FROM 025, 020 AND 030
 131 HC 3

132 KK CP-045 ROUTE FROM 030
 133 RK 600 0.007 0.030 TRAP 70 0

134 KK 045 RUNOFF HYDROGRAPH
 135 BA 0.079
 136 PB 2.50
 137 LS 93.8
 138 UD 0.137

139 KK CP-045 COMBINE HYDROGRAPHS FROM 045, CP-030
 140 HC 2

141 KK CP-050 ROUTE FROM CP-045
 142 RK 2100 0.007 0.015 TRAP 70 0

143 KK 057 RUNOFF HYDROGRAPH
 144 BA 0.527
 145 PB 2.45
 146 LS 93.8
 147 UD 0.171

148 KK CP-050
 149 RK 5900 0.007 0.015 TRAP 70 0

150 KK 050 RUNOFF HYDROGRAPH
 151 BA 0.463
 152 PB 2.45
 153 LS 93.8
 154 UD 0.185

155 KK CP-050 COMBINE HYDROGRAPHS FROM CP-045, 057, 050
 156 HC 3

157 KK CP-010 ROUTE FROM CP-050
 158 RK 1000 0.007 0.015

159 KK 010 RUNOFF HYDROGRAPH
 160 BA 0.081
 161 PB 2.75
 162 LS 83.9
 163 UD 0.087

164 KK CP-010 COMBINE HYDROGRAPHS FROM 010, CP-050
 165 HC 83.9

166 KK CP-036 ROUTE FROM CP-010
 167 RK 2100 0.007 0.015 TRAP 70 0

HEC-1 INPUT

LINE ID.....1.....2.....3.....4.....5.....6.....7.....8.....9.....10

168 KK 036 RUNOFF HYDROGRAPH
 169 BA 0.116
 170 PB 2.60
 171 LS 93.8
 172 UD 0.088

173 KK 060
 174 BA 0.146
 175 PB 2.40
 176 LS 84.2
 177 UD 0.086

178 KK CP-036 ROUTE FROM CP-060
 179 RK 500 0.007 0.015 TRAP 30 0

180 KK CP-036 COMBINE HYDROGRAPHS FROM 060, 036, CP-010
 181 HC 3

182 KK CP-A30 ROUTE FROM CP-036
 183 RK 1700 0.002 0.002 0.040 TRAP 30 0

184 KK A30 RUNOFF HYDROGRAPH
 185 BA 0.070
 186 PB 2.50
 187 LS 90.5
 188 UD 0.083

189 KK CP-A30 COMBINE HYDROGRAPHS FROM A30, CP-036, CP-A25

190 HC 3

191 KK CP-A31 ROUTE FROM CP-A30

192 RK 1000 0.002 0.040 TRAP 30 0

193 KK A28 RUNOFF HYDROGRAPH

194 BA 0.021

195 PB 2.50

196 LS 93.8

197 UD 0.041

198 KK CP-A31 RUNOFF HYDROGRAPH

199 RK 1200 0.005 0.02 TRAP 10 2

200 KK A31 RUNOFF HYDROGRAPH

201 BA 0.047

202 PB 2.60

203 LS 93.8

204 UD 0.063

205 KK CP-A31 COMBINE HYDROGRAPHS FROM CP-A30, A28, A31

206 HC 3

HEC-1 INPUT

LINE ID.....1.....2.....3.....4.....5.....6.....7.....8.....9.....10

207 KK CP-S1A ROUTE FROM CP-A31

208 RK 2600 0.002 0.040 TRAP 30 2

209 KK B10

210 KM BASIN 10

211 BA .0067

212 PB 2.0

213 LS 0 91 61

214 UD .004

215 KK B20

216 KM BASIN 20

217 BA .0055

218 LS 0 89 52

219 UD .007

220 KK C12 COMBINE B10 & B20

221 HC 2

222 KK C2 ROUTE CHANNEL NUMBER 2

223 UK 150 .020 .08 100

224 RK 620 .005 .035 TRAP 30 4

225 KK B30

226 KM BASIN 30

227 BA .0052

228 LS 0 89 43

229 UD .005

230 KK C23 COMBINE B20 OUT & B30

231 HC 2

232 KK C3 ROUTE CHANNEL NUMBER 3

233 RK 1100 .005 .035 TRAP 30 4

234 KK B40

235 KP 1

236 KM BASIN 40

237 BA .0942

238 LS 0 91 60

239 UD .024

240 KK SD43 ROUTE B40 THROUGH B30: STORM DRAIN

241 UK 1050 .020 .08 100

242 RK 800 .015 .015 CIRC 5.5

243 KK B50

244 KP 1

245 KM BASIN 50

246 BA .0781

247 LS 0 90 60

248 UD .019

HEC-1 INPUT

LINE ID.....1.....2.....3.....4.....5.....6.....7.....8.....9.....10

249 KK C45 COMBINE B40 & B50 @ B30

250 HC 2

251 KK CP4

252 BA .032

253 UK 250 .012 .08 100

254 RK 1320 .015 .015 CIRC 6 YES

255 KK CCP4

256 KM COMBINE AT CONC. PT. 4

257 HC 2

258 KK CP3

259 KM ROUTE TO CONC. PT. 3

260 BA .040

261 UK 650 .011 .08 100

262 RK 1320 .015 .015 CIRC 6 YES

263	KK	CCP3							
264	KM	COMBINE AT CONC. PT. 3							
265	HC	2							
266	KK	MX1							
267	KM	MEXICO BASIN 1							
268	BA	.0316							
269	LS	0	90	60					
270	UD	.007							
271	KK	MX2							
272	KM	MEXICO BASIN 2							
273	BA	.0781							
274	LS	0	89	50					
275	UD	.019							
276	KK	MX12							
277	KM	COMBINE MEXICO AND BORDER AREA							
278	HC	2							
279	KK	MX123							
280	KM	ROUTE TO CP3A							
281	RK	600	.015	.015		CIRC		5	
282	KK	MX3							
283	KM	BORDER CORRIDOR							
284	BA	.0215							
285	LS	0	88	30					
286	UD	.005							
287	KK	CP3A							
288	KM	COMBINE AT CONC. PT. 3A							
289	HC	2							

HEC-1 INPUT

PAGE 8

LINE ID.....1.....2.....3.....4.....5.....6.....7.....8.....9.....10

290	KK	RCP3							
291	KM	ROUTE TO CONC. PT. 3A							
292	RE	750	.015	.015		CIRC		5	
293	KK	CCP3							
294	KM	COMBINE AT CONC. PT. 3							
295	HC	2							
296	KK	RCP2							
297	KM	ROUTE TO CONC. PT. 2							
298	RK	400	.015	.015		CIRC		7	
299	KK	RP2							
300	KM	RUNOFF TO CONC. PT. 2							
301	BA	.0473							
302	UK	550	.012	.08	100				
303	RK	1200	.015	.015		CIRC		4	
304	KK	CCP2							
305	KM	COMBINE AT CONC. PT. 2							
306	HC	2							
307	KK	SVRW							
308	KM	SIEMPRE VIVA RD WATSHED							
309	BA	.0646							
310	UK	450	.015	.08	100				
311	RK	3000	.015	.015		CIRC		5	
312	KK	RB							
313	KM	WATSHED EAST OF PREVIOUS DET. BASIN							
314	BA	.0102							
315	UK	250	.010	.08	100				
316	RE	100	.015	.015		CIRC		2	
317	KK	WB							
318	KM	WATSHED WEST OF PREVIOUS DET. BASIN							
319	BA	.0158							
320	UK	400	.010	.08	100				
321	RE	100	.015	.015		CIRC		2	
322	KK	WSVR							
323	KM	WEST SIEMPRE VIVA RD.							
324	BA	.0108							
325	UK	350	.012	.08	100				
326	RE	600	.015	.015		CIRC		4	
327	KK	CP1							
328	HC	5							

HEC-1 INPUT

PAGE 9

LINE ID.....1.....2.....3.....4.....5.....6.....7.....8.....9.....10

329	KK	S1	RUNOFF HYDROGRAPH						
330	BA	0.516							
331	PR	2.70							
332	LS		93.8						
333	UD	0.143							
334	KK	CP-S1	COMBINE HYDROGRAPHS FROM H10, CP1 AND S1						
335	HC	3							

336 KK CP-S1A COMBINE HYDROGRAPHS FROM CP-S1, CP-A31
 337 HC 2

 338 KK CP-S10 ROUTE FROM CP-S1A
 339 RK 1300 0.004 0.004 TRAP 30 0

 340 KK A60 RUNOFF HYDROGRAPH
 341 BA 0.033
 342 PB 2.30
 343 LS 93.8
 344 UD 0.039

 345 KK CP-A50 ROUTE FROM A60
 346 RK 3000 0.005 0.013 CIRC 2

 347 KK 055 RUNOFF HYDROGRAPH
 348 BA 0.482
 349 PB 2.35
 350 LS 91.7
 351 UD 0.140

 352 KK CP-A50 ROUTE FROM 055
 353 RK 2900 0.004 0.013 TRAP 15 0

 354 KK A50 RUNOFF HYDROGRAPH
 355 BA 0.250
 356 PB 2.35
 357 LS 93.8
 358 UD 0.121

 359 KK CP-A50 COMBINE HYDROGRAPHS FROM A60, 055, AND A50
 360 HC 3

 361 KK A50
 362 DT A50
 363 DI 0 615 1000
 364 DQ 0 0.01 385

 365 KK A42 RUNOFF HYDROGRAPH
 366 BA 0.032
 367 PB 2.40
 368 LS 93.8
 369 UD 0.046

HEC-1 INPUT

1

LINE ID.....1.....2.....3.....4.....5.....6.....7.....8.....9.....10

370 KK CP-A50 COMBINE HYDROGRAPHS FROM A50 AND A42
 371 HC 2

 372 KK CP-A45 ROUTE FROM CP-A50
 373 RK 3000 0.002 0.040 TRAP 40 1

 374 KK A40 RUNOFF HYDROGRAPH
 375 BA 0.032
 376 PB 2.40
 377 LS 93.8
 378 UD 0.057

 379 KK CP-A45 ROUTE FROM A40
 380 RK 2380 0.006 0.040 TRAP 40 1

 381 KK A35 RUNOFF HYDROGRAPH
 382 BA 0.065
 383 PB 2.50
 384 LS 93.8
 385 UD 0.076

 386 KK CP-A45 ROUTE FROM A35
 387 RK 2000 0.001 0.040 TRAP 5 1

 388 KK A45 RUNOFF HYDROGRAPH
 389 BA 0.122
 390 PB 2.45
 391 LS 94.0
 392 UD 0.112

 393 KK CP-A45 COMBINE HYDROGRAPHS FROM CP-A50, A40 AND A45
 394 HC 4

 395 KK A45
 396 DT A45
 397 DI 0 60 1000
 398 DQ 0 0.01 940

 399 KK CP-S10 ROUTE FROM CP-A45
 400 RK 2900 0.003 0.040 TRAP 25 0.8

 401 KK S10 RUNOFF FROM HYDROGRAPH
 402 BA 0.263
 403 PB 2.50
 404 LS 94.4
 405 UD 0.235

 406 KK CP-S10 COMBINE HYDROGRAPHS FROM S1-DET, CP-A45, AND S10
 407 HC 3

HEC-1 INPUT

1

LINE ID.....1.....2.....3.....4.....5.....6.....7.....8.....9.....10

408	KK	CP-B30	ROUTE FROM CP-S10						
409	RD	2400	0.004 0.040	TRAP	50	0.8			
410	KK	A65	RUNOFF HYDROGRAPH FROM A65						
411	BA	0.055							
412	PB	2.30							
413	LS		93.8						
414	UD	0.037							
415	KK	CP-S25	ROUTE FROM A65						
416	RK	2910	0.010 0.040	TRAP	200	20			
417	KK	S25	RUNOFF HYDROGRAPH						
418	BA	0.062							
419	PB	2.30							
420	LS		83.9						
421	UD	0.202							
422	KK	CP-S25	COMBINE HYDROGRAPHS FROM A65 AND S25						
423	HC	2							
424	KK	CP-S20	ROUTE FROM CP-S25						
425	RK	1460	0.004 0.020	TRAP	15	1.1			
426	KK	S20	RUNOFF HYDROGRAPH						
427	BA	0.136							
428	PB	2.30							
429	LS		83.9						
430	UD	0.176							
431	KK	CP-S20	COMBINE HYDROGRAPHS FROM CP-S25, AND S20						
432	HC	2							
433	KK	CP-B30	ROUTE FROM CP-S20						
434	RK	3500	0.004 0.040	TRAP	15	1			
435	KK	S15	RUNOFF HYDROGRAPH						
436	BA	0.128							
437	PB	2.40							
438	LS		93.8						
439	UD	0.083							
440	KK	CP-B30	ROUTE FROM S15						
441	RK	2800	0.004 0.040	TRAP	15	1			
442	KK	B20	RUNOFF HYDROGRAPH						
443	BA	0.040							
444	PB	2.30							
445	LS		93.8						
446	UD	0.051							

HRC-1 INPUT

PAGE 13

1

LINE	ID	1	2	3	4	5	6	7	8	9	10
447	KK	CP-B25	ROUTE FROM B20								
448	RK	1320	0.002 0.020	TRAP	8	2.3					
449	KK	B25	RUNOFF HYDROGRAPH								
450	BA	0.127									
451	PB	2.30									
452	LS		93.8								
453	UD	0.070									
454	KK	CP-B25	COMBINE HYDROGRAPHS FROM B20 AND B25								
455	HC	2									
456	KK	CP-B25	ROUTE FROM CP-B25								
457	RK	2700	0.001 0.040	TRAP	15	1					
458	KK	B15	RUNOFF HYDROGRAPH								
459	BA	0.074									
460	PB	2.50									
461	LS		94.5								
462	UD	0.078									
463	KK	CP-B30									
464	RK	1000	0.015 0.040	TRAP	15	3					
465	KK	B30	RUNOFF HYDROGRAPH								
466	BA	0.228									
467	PB	2.45									
468	LS		84.8								
469	UD	0.465									
470	KK	CP-B30	COMBINE HYDROGRAPHS FROM CP-S10, CP-S20, S15, CP-B25, B15 AND B30								
471	RO	1									
472	HC	6									
473	KK	DE-030	DETENTION BASIN AT BORDER								
474	RS	1	STOR								
475	SV	0	11	71	166	268	319				
476	SE	0	2	4	6	8	9				
477	SQ	0	20	150	350	1000	2200				
478	ZZ										

1

SCHEMATIC DIAGRAM OF STREAM NETWORK

INPUT
LINE

(V) ROUTING

(--->) DIVERSION OR PUMP FLOW

NO. (.) CONNECTOR [---] RETURN OF DIVERTED OR PUMPED FLOW

```

14      A1
      .
37      .      A7
      .
42      .      .      01
      .
47      CP-01 .....
      V
      V
49      CP-A15
      .
51      .      A5
      .      V
56      .      CP-A10
      .
58      .      .      A10
      .
63      .      CP-A10 .....
      .      V
65      .      CP-A15
      .
67      .      .      A15
      .
72      CP-A15 .....
      V
74      CP-A20
      .
76      .      .      05
      .      .      V
81      .      CP-A20
      .
83      .      .      A20
      .
88      .      .      .      A25
      .
93      .      .      .      .      A27
      .
98      CP-A20 .....
      V
100     CP-A25
      .
102     .      A23
      .      V
107     .      CP-A25
      .
109     CP-A25 .....
      V
111     CP-A30
      .
113     .      .      025
      .
118     .      .      .      020
      .      .      V
123     .      .      CP-030
      .
125     .      .      .      030
      .
130     .      CP-030 .....
      .      V
132     .      CP-045
      .
134     .      .      045
      .
139     .      CP-045 .....
      .      V
141     .      CP-050
      .

```

143
148
150
155
157
159
164
166
168
173
178
180
182
184
189
191
193
198
200
205
207
209
215
220
222
225
230
232
234
240
243
249
251
255

057
V
CP-050

OTI-2

050

CP-050

V

V

CP-010

010

CP-010

V

V

CP-036

036

060
V
CP-036

OTI-4

~~CP-036~~

V

V

CP-A30

A30

CP-A30

V

V

CP-A31

A28

V

V

CP-A31

A31

CP-A31

V

V

CP-S1A

OTI-8+9

B10

B20

C12

C2

B30

C23

V

V

C3

B40

SD43

B50

C45

V

V

CP4 ***

CCP4

V

258	.	.	V	CP3 ***
263	.	CCP3
266	.	.	.	MX1
271	MX2	.	.
276	.	.	.	MX12
279	.	.	.	V
282	.	.	.	MX123
287	MX3	.	.
290	.	.	.	CP3A
293	.	CCP3	V
296	.	RCP2	.	V
299	.	.	.	RP2
304	.	CCP2
307	.	.	.	SVRW
312	EB	.	.
317	WB	.
322	WSVR
327	.	CP1
329	.	.	.	S1
334	.	CP-S1
336	CP-S1A
338	CP-S10
340	.	.	.	A60
345	.	CP-A50
347	.	.	.	055
352	.	CP-A50
354	.	.	.	A50
359	.	CP-A50
362	.	.	.	A50
365	.	.	.	A42
370	.	CP-A50
372	.	CP-A45
374	.	.	.	A40

Siempre Vía BP

OT1-3

```

379      . . . . . CP-A45
381      . . . . .      A35
386      . . . . .      V
386      . . . . .      V
386      . . . . . CP-A45
368      . . . . .      A45
393      . . . . . CP-A45
396      . . . . .      A45
395      . . . . .      A45
399      . . . . .      V
399      . . . . .      V
399      . . . . . CP-S10
401      . . . . .      S10
406      . . . . . CP-S10
408      . . . . . CP-B30
410      . . . . .      A65
415      . . . . .      V
415      . . . . .      V
415      . . . . . CP-S25
417      . . . . .      S25
422      . . . . . CP-S25
424      . . . . .      V
424      . . . . .      V
424      . . . . . CP-S20
426      . . . . .      S20
431      . . . . . CP-S20
433      . . . . .      V
433      . . . . .      V
433      . . . . . CP-B30
435      . . . . .      S15
440      . . . . .      V
440      . . . . .      V
440      . . . . . CP-B30
442      . . . . .      B20
447      . . . . .      V
447      . . . . .      V
447      . . . . . CP-B25
449      . . . . .      B25
454      . . . . . CP-B25
456      . . . . .      V
456      . . . . .      V
456      . . . . . CP-B25
458      . . . . .      B15
463      . . . . .      V
463      . . . . .      V
463      . . . . . CP-B30
465      . . . . .      B30
470      . . . . . CP-B30
473      . . . . . DB-030

```

OTI-12

OTI-11

OTI-14

*** RUNOFF ALSO COMPUTED AT THIS LOCATION

```

* FLOOD HYDROGRAPH PACKAGE (HEC-1) *
* ENGINEERS *
* JUN 1998 *
* CENTER *
* VERSION 4.1 *
* STREET *

```

```

* U.S. ARMY CORPS OF
* HYDROLOGIC ENGINEERING
* 609 SECOND

```

95616

RUN DATE 21DEC04 TIME 07:23:00

DAVIS, CALIFORNIA

(916) 756-1104

.....1.....2.....3.....4.....5.....6.....7.....8.....9.....10

OTAY MESA HYDROLOGY

KIMLEY-HORN AND ASSOCIATES, INC.
100 YEAR, 6 HOUR STORM EVENT
FILE: IN*9300WDB-SD-IN1.TXT OUT 9300WDB-015
LSM 8-31-98, MODIFIED 7-27-99 BY SLM

OUTPUT CONTROL VARIABLES

IPRNT 0 PRINT CONTROL
IPLST 0 PLOT CONTROL
QSCAL 0 HYDROGRAPH PLOT SCALE

HYDROGRAPH TIME DATA

NMIN 3 MINUTES IN COMPUTATION INTERVAL
IDATE 1 0 STARTING DATE
ITIME 0000 STARTING TIME
NQ 100 NUMBER OF HYDROGRAPH ORDINATES
NDDATE 1 0 ENDING DATE
NDTIME 0958 ENDING TIME
ICENT 19 CENTURY MARK

COMPUTATION INTERVAL .03 HOURS
TOTAL TIME BASE 9.97 HOURS

ENGLISH UNITS

DRAINAGE AREA SQUARE MILES
PRECIPITATION DEPTH INCHES
LENGTH, ELEVATION FEET
FLOW CUBIC FEET PER SECOND
STORAGE VOLUME ACRE-Feet
SURFACE AREA ACRES
TEMPERATURE DEGREES FAHRENHEIT

473 KK DE-030 DETENTION BASIN AT BORDER

HYDROGRAPH ROUTING DATA

474 RS STORAGE ROUTING
NSTPS 1 NUMBER OF SUBREACHES
ITYP STOR TYPE OF INITIAL CONDITION
RSVRIC .00 INITIAL CONDITION
X .00 WORKING R AND D COEFFICIENT
475 SV STORAGE .0 11.0 71.0 166.0 268.0 319.0
476 SE ELEVATION .00 2.00 4.00 6.00 8.00 9.00
477 SQ DISCHARGE 0. 20. 150. 350. 1000. 2200.

HYDROGRAPH AT STATION DB-030

Table with columns: DA MON STORAGE, HRMN STAGE, HRMN ORD, OUTFLOW, STORAGE, STAGE, DA MON STORAGE, HRMN ORD, OUTFLOW, STORAGE, STAGE, DA MON HRMN ORD, OUTFLOW. Rows show data for stages 1 through 5.

1	0150	56	12.	6.4	1.2 * 1	0510	156	839.	242.7	7.5 * 1	0830	256	338.
160.1	5.9												
1	0152	57	12.	6.8	1.2 * 1	0512	157	837.	242.4	7.5 * 1	0832	257	336.
159.2	5.9												
1	0154	58	13.	7.3	1.3 * 1	0514	158	835.	242.1	7.5 * 1	0834	258	334.
158.3	5.8												
1	0156	59	14.	7.8	1.4 * 1	0516	159	833.	241.8	7.5 * 1	0836	259	332.
157.5	5.8												
1	0158	60	15.	8.4	1.5 * 1	0518	160	831.	241.4	7.5 * 1	0838	260	330.
156.6	5.8												
1	0200	61	17.	9.1	1.7 * 1	0520	161	829.	241.1	7.5 * 1	0840	261	328.
155.8	5.8												
1	0202	62	18.	9.9	1.8 * 1	0522	162	826.	240.8	7.5 * 1	0842	262	327.
154.9	5.8												
1	0204	63	19.	10.7	1.9 * 1	0524	163	824.	240.4	7.5 * 1	0844	263	325.
154.1	5.7												
1	0206	64	21.	11.7	2.0 * 1	0526	164	822.	240.1	7.5 * 1	0846	264	323.
153.2	5.7												
1	0208	65	24.	12.8	2.1 * 1	0528	165	820.	239.7	7.4 * 1	0848	265	321.
152.4	5.7												
1	0210	66	27.	14.2	2.1 * 1	0530	166	817.	239.3	7.4 * 1	0850	266	320.
151.5	5.7												
1	0212	67	31.	16.0	2.2 * 1	0532	167	815.	238.9	7.4 * 1	0852	267	318.
150.7	5.7												
1	0214	68	36.	18.5	2.2 * 1	0534	168	812.	238.6	7.4 * 1	0854	268	316.
149.9	5.7												
1	0216	69	43.	21.7	2.4 * 1	0536	169	810.	238.2	7.4 * 1	0856	269	314.
149.0	5.6												
1	0218	70	52.	25.8	2.5 * 1	0538	170	808.	237.8	7.4 * 1	0858	270	313.
148.2	5.6												
1	0220	71	63.	30.8	2.7 * 1	0540	171	805.	237.4	7.4 * 1	0900	271	311.
147.4	5.6												
1	0222	72	76.	36.8	2.9 * 1	0542	172	803.	237.0	7.4 * 1	0902	272	309.
146.6	5.6												
1	0224	73	91.	43.7	3.1 * 1	0544	173	800.	236.7	7.4 * 1	0904	273	307.
145.8	5.6												
1	0226	74	108.	51.5	3.3 * 1	0546	174	798.	236.3	7.4 * 1	0906	274	306.
145.0	5.6												
1	0228	75	126.	59.9	3.6 * 1	0548	175	795.	235.9	7.4 * 1	0908	275	304.
144.1	5.5												
1	0230	76	145.	68.7	3.9 * 1	0550	176	793.	235.5	7.4 * 1	0910	276	302.
143.3	5.5												
1	0232	77	165.	77.9	4.1 * 1	0552	177	790.	235.1	7.4 * 1	0912	277	301.
142.5	5.5												
1	0234	78	185.	87.4	4.3 * 1	0554	178	788.	234.7	7.3 * 1	0914	278	299.
141.7	5.5												
1	0236	79	205.	97.0	4.5 * 1	0556	179	786.	234.3	7.3 * 1	0916	279	297.
141.0	5.5												
1	0238	80	225.	106.4	4.7 * 1	0558	180	783.	234.0	7.3 * 1	0918	280	296.
140.2	5.5												
1	0240	81	244.	115.6	4.9 * 1	0600	181	781.	233.6	7.3 * 1	0920	281	294.
139.4	5.4												
1	0242	82	262.	124.3	5.1 * 1	0602	182	778.	233.2	7.3 * 1	0922	282	292.
138.6	5.4												
1	0244	83	280.	132.7	5.3 * 1	0604	183	776.	232.8	7.3 * 1	0924	283	291.
137.8	5.4												
1	0246	84	296.	140.5	5.5 * 1	0606	184	773.	232.4	7.3 * 1	0926	284	289.
137.0	5.4												
1	0248	85	312.	147.8	5.6 * 1	0608	185	771.	232.1	7.3 * 1	0928	285	287.
136.3	5.4												
1	0250	86	326.	154.5	5.8 * 1	0610	186	768.	231.6	7.3 * 1	0930	286	286.
135.5	5.4												
1	0252	87	339.	160.9	5.9 * 1	0612	187	765.	231.2	7.3 * 1	0932	287	284.
134.8	5.3												
1	0254	88	355.	166.7	6.0 * 1	0614	188	762.	230.7	7.3 * 1	0934	288	283.
134.0	5.3												
1	0256	89	389.	172.2	6.1 * 1	0616	189	759.	230.1	7.3 * 1	0936	289	281.
133.2	5.3												
1	0258	90	421.	177.2	6.2 * 1	0618	190	755.	229.6	7.2 * 1	0938	290	279.
132.5	5.3												
1	0300	91	451.	181.8	6.3 * 1	0620	191	751.	228.9	7.2 * 1	0940	291	278.
131.7	5.3												
1	0302	92	478.	186.1	6.4 * 1	0622	192	747.	228.2	7.2 * 1	0942	292	276.
131.0	5.3												
1	0304	93	504.	190.2	6.5 * 1	0624	193	742.	227.5	7.2 * 1	0944	293	275.
130.3	5.2												
1	0306	94	529.	194.1	6.6 * 1	0626	194	737.	226.7	7.2 * 1	0946	294	273.
129.5	5.2												
1	0308	95	552.	197.8	6.6 * 1	0628	195	732.	225.9	7.2 * 1	0948	295	272.
128.8	5.2												
1	0310	96	575.	201.3	6.7 * 1	0630	196	726.	225.0	7.2 * 1	0950	296	270.
128.1	5.2												
1	0312	97	596.	204.6	6.8 * 1	0632	197	720.	224.1	7.1 * 1	0952	297	269.
127.3	5.2												
1	0314	98	615.	207.7	6.8 * 1	0634	198	714.	223.1	7.1 * 1	0954	298	267.
126.6	5.2												
1	0316	99	634.	210.5	6.9 * 1	0636	199	708.	222.1	7.1 * 1	0956	299	266.
125.9	5.2												
1	0318	100	651.	213.2	6.9 * 1	0638	200	701.	221.1	7.1 * 1	0958	300	264.
125.2	5.1												

.....

PEAK FLOW (CFS)	TIME (HR)	MAXIMUM AVERAGE FLOW				
		6-HR	24-HR	72-HR	9.97-HR	
859.	4.53	(CFS)	658.	441.	441.	441.
		(INCHES)	.954	1.061	1.061	1.061

+		020	147.	2.57	36.	22.	22.	.26
+	ROUTED TO	CP-030	146.	2.67	36.	22.	22.	.26
+	HYDROGRAPH AT	030	65.	2.53	15.	9.	9.	.13
+	3 COMBINED AT	CP-030	276.	2.60	68.	41.	41.	.53
+	ROUTED TO	CP-045	275.	2.60	68.	41.	41.	.53
+	HYDROGRAPH AT	045	95.	2.33	16.	9.	9.	.08
+	2 COMBINED AT	CP-045	329.	2.57	84.	51.	51.	.61
+	ROUTED TO	CP-050	328.	2.60	84.	51.	51.	.61
+	HYDROGRAPH AT	057	575.	2.37	102.	62.	62.	.53
+	ROUTED TO	CP-050	570.	2.47	102.	62.	62.	.53
+	HYDROGRAPH AT	050	493.	2.40	90.	54.	54.	.46
+	3 COMBINED AT	CP-050	1301.	2.47	275.	166.	166.	1.60
+	ROUTED TO	CP-010	1299.	2.50	275.	166.	166.	1.60
+	HYDROGRAPH AT	010	68.	2.30	11.	7.	7.	.08
+	2 COMBINED AT	CP-010	1346.	2.50	286.	173.	173.	1.68
+	ROUTED TO	CP-036	1345.	2.50	287.	173.	173.	1.68
+	HYDROGRAPH AT	036	166.	2.27	24.	15.	15.	.12
+	HYDROGRAPH AT	060	95.	2.30	17.	10.	10.	.15
+	ROUTED TO	CP-036	94.	2.30	17.	10.	10.	.15
+	3 COMBINED AT	CP-036	1508.	2.50	327.	198.	198.	1.94
+	ROUTED TO	CP-A30	1507.	2.50	327.	198.	198.	1.94
+	HYDROGRAPH AT	A30	78.	2.27	12.	7.	7.	.07
+	3 COMBINED AT	CP-A30	2150.	2.50	514.	312.	312.	3.04
+	ROUTED TO	CP-A31	2145.	2.50	514.	312.	312.	3.04
+	HYDROGRAPH AT	A28	34.	2.23	4.	3.	3.	.02
+	ROUTED TO	CP-A31	33.	2.27	4.	3.	3.	.02
+	HYDROGRAPH AT	A31	71.	2.27	10.	6.	6.	.05
+	3 COMBINED AT	CP-A31	2196.	2.50	528.	321.	321.	3.11
+	ROUTED TO	CP-S1A	2184.	2.57	527.	320.	320.	3.11
+	HYDROGRAPH AT	B10	8.	2.20	1.	1.	1.	.01
+	HYDROGRAPH AT	B20	7.	2.20	1.	1.	1.	.01
+	2 COMBINED AT	C12	16.	2.20	2.	1.	1.	.01
+	HYDROGRAPH AT	C2	5.	2.33	1.	1.	1.	.01
+	HYDROGRAPH AT	B30	6.	2.20	1.	0.	0.	.01

+	2 COMBINED AT	C23	9.	2.27	2.	1.	1.	.01
+	ROUTED TO	C3	9.	2.40	2.	1.	1.	.01
+	HYDROGRAPH AT	B40	127.	2.20	17.	10.	10.	.09
+	HYDROGRAPH AT	SD43	64.	2.47	16.	10.	10.	.09
+	HYDROGRAPH AT	B50	104.	2.20	14.	8.	8.	.08
+	2 COMBINED AT	C45	139.	2.20	29.	18.	18.	.17
+	HYDROGRAPH AT	CP4	163.	2.23	35.	22.	22.	.20
+	2 COMBINED AT	CCP4	283.	2.20	52.	32.	32.	.30
+	HYDROGRAPH AT	CP3	302.	2.23	58.	36.	36.	.34
+	2 COMBINED AT	CCP3	304.	2.23	60.	37.	37.	.35
+	HYDROGRAPH AT	MX1	42.	2.20	6.	3.	3.	.03
+	HYDROGRAPH AT	MX2	95.	2.20	13.	8.	8.	.08
+	2 COMBINED AT	MX12	137.	2.20	18.	11.	11.	.11
+	ROUTED TO	MX123	136.	2.20	18.	11.	11.	.11
+	HYDROGRAPH AT	MX3	22.	2.20	3.	2.	2.	.02
+	2 COMBINED AT	CP3A	158.	2.20	21.	13.	13.	.13
+	ROUTED TO	RCP3	155.	2.20	21.	13.	13.	.13
+	2 COMBINED AT	CCP3	455.	2.23	81.	50.	50.	.48
+	ROUTED TO	RCP2	454.	2.23	81.	50.	50.	.48
+	HYDROGRAPH AT	RP2	26.	2.50	6.	4.	4.	.05
+	2 COMBINED AT	CCP2	468.	2.23	87.	54.	54.	.53
+	HYDROGRAPH AT	SVRW	40.	2.47	9.	5.	5.	.06
+	HYDROGRAPH AT	EB	7.	2.37	1.	1.	1.	.01
+	HYDROGRAPH AT	WB	10.	2.47	2.	1.	1.	.02
+	HYDROGRAPH AT	WSVR	7.	2.40	1.	1.	1.	.01
+	5 COMBINED AT	CP1	503.	2.23	100.	62.	62.	.63
+	HYDROGRAPH AT	S1	679.	2.33	113.	68.	68.	.52
+	3 COMBINED AT	CP-S1	1116.	2.33	216.	132.	132.	1.16
+	2 COMBINED AT	CP-S1A	2955.	2.53	736.	452.	452.	4.26
+	ROUTED TO	CP-S10	2950.	2.53	736.	452.	452.	4.26
+	HYDROGRAPH AT	A60	45.	2.23	6.	4.	4.	.03
+	ROUTED TO	CP-A50	44.	2.30	6.	4.	4.	.03
+	HYDROGRAPH AT	O55	463.	2.33	79.	48.	48.	.48
+	ROUTED TO	CP-A50	462.	2.37	79.	48.	48.	.48

La Media

+	HYDROGRAPH AT	A50	287.	2.33	46.	28.	28.	.25
+	3 COMBINED AT	CP-A50	771.	2.33	131.	79.	79.	.76
+	DIVERSION TO	A50	156.	2.33	4.	2.	2.	.76
+	HYDROGRAPH AT	A50	615.	2.33	127.	77.	77.	.76
+	HYDROGRAPH AT	A42	46.	2.23	6.	4.	4.	.03
+	2 COMBINED AT	CP-A50	658.	2.27	133.	80.	80.	.80
+	ROUTED TO	CP-A45	653.	2.40	133.	80.	80.	.80
+	HYDROGRAPH AT	A40	45.	2.23	6.	4.	4.	.03
+	ROUTED TO	CP-A45	44.	2.43	6.	4.	4.	.03
+	HYDROGRAPH AT	A35	92.	2.27	13.	8.	8.	.06
+	ROUTED TO	CP-A45	90.	2.43	13.	8.	8.	.06
+	HYDROGRAPH AT	A45	154.	2.30	24.	14.	14.	.12
+	4 COMBINED AT	CP-A45	915.	2.40	176.	106.	106.	1.02
+	DIVERSION TO	A45	855.	2.37	126.	76.	76.	1.02
+	HYDROGRAPH AT	A45	60.	2.37	50.	31.	31.	1.02
+	ROUTED TO	CP-S10	60.	2.60	50.	30.	30.	1.02
+	HYDROGRAPH AT	S10	273.	2.47	54.	32.	32.	.26
+	3 COMBINED AT	CP-S10	3270.	2.53	819.	515.	515.	5.54
+	ROUTED TO	CP-B30	3217.	2.60	838.	514.	514.	5.54
+	HYDROGRAPH AT	A65	76.	2.23	10.	6.	6.	.05
+	ROUTED TO	CP-S25	74.	2.53	10.	6.	6.	.05
+	HYDROGRAPH AT	S25	38.	2.47	8.	5.	5.	.08
+	2 COMBINED AT	CP-S25	111.	2.53	19.	11.	11.	.14
+	ROUTED TO	CP-S20	108.	2.57	19.	11.	11.	.14
+	HYDROGRAPH AT	S20	66.	2.43	14.	8.	8.	.14
+	2 COMBINED AT	CP-S20	166.	2.57	33.	20.	20.	.27
+	ROUTED TO	CP-B30	162.	2.73	32.	20.	20.	.27
+	HYDROGRAPH AT	S15	167.	2.27	24.	15.	15.	.13
+	ROUTED TO	CP-B30	163.	2.37	24.	15.	15.	.13
+	HYDROGRAPH AT	B30	54.	2.23	7.	4.	4.	.04
+	ROUTED TO	CP-B25	52.	2.30	7.	4.	4.	.04
+	HYDROGRAPH AT	B25	162.	2.27	23.	14.	14.	.13
+	2 COMBINED AT	CP-B25	212.	2.27	30.	18.	18.	.17
+	ROUTED TO							

		<i>Mk</i>	<i>Area</i>	<i>6</i>	<i>24</i>	<i>72</i>	<i>Area</i>
	CP-B25	209.	2.41	30.	18.	18.	.17
	HYDROGRAPH AT						
	B15	108.	2.27	15.	9.	9.	.07
	ROUTED TO						
	CP-B30	107.	2.30	15.	9.	9.	.07
	HYDROGRAPH AT						
	B30	90.	2.80	28.	17.	17.	.23
	6 COMBINED AT						
	CP-B30	3673.	2.60	967.	593.	593.	6.41
	ROUTED TO						
	DB-030	859.	4.53	658.	441.	441.	6.41
							7.57

4.53
1

SUMMARY OF KINEMATIC WAVE - MUSKINGUM-CUNGE ROUTING

6.78 mi²

APPENDIX G-2

Review of Otay Mesa Drainage Studies

Review of Otay Mesa Drainage Studies

Contract H084445

Task Order No. 16



Review of Otay Mesa Drainage Studies

Contract H084445

Task Order No. 16

Table of Contents

I.	Introduction.....	4
II.	Review of Completed and Draft Planning and Engineering Reports.....	5
A.	Introduction.....	5
B.	Review of Pertinent Notices and Planning Reports.....	5
C.	Impetus of Drainage Studies.....	11
III.	Data Compilation and Review.....	12
A.	Data Compilation.....	12
B.	Drainage Areas.....	12
C.	Zoning Status.....	13
D.	Land Uses.....	14
E.	Soils.....	15
F.	Vegetation.....	17
IV.	Environmentally Sensitive Lands.....	18
A.	Vernal Pool Background.....	18
B.	Otay Mesa Vernal Pools.....	18
V.	Review of Stormwater Regulations.....	20
A.	Federal Regulations and Permits.....	20
B.	State Regulations and Permits.....	23
C.	Local Regulations and Permits.....	25
D.	County Regulations and Permits.....	31
E.	International Regulations and Permits.....	31
VI.	Drainage Requirements, Considerations, and Opportunities.....	31
A.	Consideration 1: Drainage and Runoff Management Responsibilities.....	32
B.	Consideration 2: Potential for BMPs.....	33
C.	Consideration 3: Estimated Annualized Costs for Planning, Permitting, Land Acquisition, Design, Construction, and Maintenance of Stormwater and Drainage Infrastructure.....	36
D.	Consideration 4: Risk-Based Analyses.....	38
E.	Consideration 5: Border Issues.....	39
VII.	Conclusions.....	41
VIII.	References.....	42

List of Tables

Table 1. Drainage Area Sizes	13
Table 2. Zoning Status for Drainage Areas.....	14
Table 3. Land uses for Drainage Areas	15
Table 4. Soils for Drainage Areas	16
Table 5. Vegetation Coverage for Drainage Areas.....	17
Table 6. Summary of biological survey requirements.....	29
Table 7: Per Unit Cost Estimates for Construction Components.....	37

List of Figures

Figure 1. Location of Otay Mesa.....	4
Figure 2. Defined Drainage Areas	13
Figure 3. Zoning Status.....	14
Figure 4. Land Uses.....	15
Figure 5. Soils	16
Figure 6. Vegetation of Otay Mesa	17
Figure 7. Location of vernal pools at the J28 East site (blue areas; blue hashed area depicts the MHPA).....	30
Figure 8. Location of vernal pools at the J21 site (blue areas; blue hashed area depicts the MHPA).....	30
Figure 9. 100-year Floodplain in the Water Tanks (East) drainage area (Kimley-Horn and Associate, 2007).	33
Figure 10. Suitable Areas for Vernal Pools with 9% or less Slope and 0.06 inches/hour or less Permeability	35
Figure 11. Potential Areas for Vernal Pools within the Water Tanks (East) drainage area.....	35
Figure 12. Risk-Based Design Costs Analyses Concepts	39

I. Introduction

Otay Mesa is a community located within the City of San Diego. Originally developed as an industrial area in 1985 in response to the creation of a U.S./Mexico border crossing, Otay Mesa now includes residential areas, an airport, and more than 1200 companies which sell and ship directly to Mexico or utilize the labor pool that commutes from Tijuana. Current development projects in the area include a major transportation project, State Route 905, to improve traffic in the region, with completion anticipated by 2013. With this, continued industrial and residential growth is anticipated. See Figure 1 for a map of Otay Mesa's location.



Figure 1. Location of Otay Mesa

Prior to development, the region was primarily an agricultural community. Effects of increased development were identified soon after it began. Because most of the Mesa drains south towards Mexico, concern arose over increased stormwater runoff crossing the border. In 1987, the City Council approved a contract to prepare the Otay Mesa Master Drainage Plan and published a Notice to "All Private Engineers" that established drainage requirements for development in Otay Mesa. The Notice required no increase in the rate of stormwater runoff from the property after development than it was before development, by the construction of stormwater detention basins on-site. The Notice also

indicated the plans of the City's Engineer Office, Flood Control Section, to prepare a plan for a main north-south channel from Otay Mesa Road to the Mexican border. The *Otay Mesa Drainage Master Plan- Preliminary Channel Design* was published in January 1988, and was updated in August 1999 (*Otay Mesa Drainage Study*), May 2005 (*Otay Mesa Community Plan Update*), and April 2007 (*Drainage Study for the Otay Mesa Community Plan Update*.)

Most existing drainage facilities were constructed as part of private development. These facilities are discontinuous because of the nature of individual development projects, which creates difficulties for subsequent developers that need to connect to private drainage facilities. Most development has occurred in the East Watershed of the Mesa, where most existing drainage facilities are located. These facilities consist of a system of storm drains, improved channels, and detention basins. Many of the detention basins discharge to natural drainages, which do not have adequate hydraulic capacity. Flooding therefore occurs occasionally in the area.

Because of continuing development in the area, recommendations and guidance provided in the previous drainage reports quickly become outdated. This document provides a review of the previous reports and summarizes report recommendations. Current land use and drainage patterns, as well as regulations regarding stormwater are also reviewed to provide up-to-date considerations and recommendations for the placement of storm water management facilities and to shed light on potential restoration projects that may be required to mitigate impacts to sensitive areas (e.g., vernal pools).

II. Review of Completed and Draft Planning and Engineering Reports

A. Introduction

The purpose of this report is to provide a summary of the engineering reports to gain a better understanding on the motivation behind the reports and to highlight considerations that may require additional thought weighed if progress were to be made in implementing the projects contained within the engineering reports.

B. Review of Pertinent Notices and Planning Reports

The following sections are a summary of four engineering reports for the Otay Mesa that were supplied to Tetra Tech by the City of San Diego.

August 7, 1987. Notice to All Private Engineers

The notice required all property in Otay Mesa that is within the watershed that drains to Mexico to be developed with the following requirements:

- Each property owner shall provide stormwater detention facilities so that there will be no increase in the rate of runoff due to development of the property.
- The detention facility shall be designed so that the rate of runoff from the property will be no greater after development than it was before development for a 5-year, 10-year, 25-year, and 50-year storm.
- All drainage facilities crossing four-lane major or higher classification streets shall be designed for a Q100 (existing). Other facilities, except the major channel described below, may be designed for Q50 (existing).

- The Drainage Design Manual shall be used as guidelines for design of drainage facilities, and computing design discharges.
- The City's Engineer Office, Flood Control Section, is preparing a preliminary plan for the main north-south channel from Otay Mesa Road near La Media to the Mexican border. The preliminary design will include the design Q (Q100 existing), the invert grade and the water surface elevation at the major road crossings.

January 1988. Otay Mesa Drainage Master Plan – Preliminary Channel Design

This document provided the initial preliminary design for the main channel indicated in the Notice, above.

Introduction: To prevent flooding problems, the City has required individual developments to regulated runoff from their property. The Mesa is zoned for industrial and commercial use. To allow for the planning and development of the area, an area-wide drainage collection and conveyance system is needed to serve the many individual properties. The report presented a preliminary channel design for a main channel to give Otay Mesa developers a basis for the design of the individual property storm drains.

Hydrologic Analyses: The hydrologic analysis was conducted using the US Army Corp of Engineers (US ACE) HEC-1 flood hydrograph computer model. The watershed was divided into 53 subareas, and the design storm was a 100-year, 6-hour event. The precipitation for the design event was estimated for the 53 subareas from the NOAA isopluvial map for San Diego. Other inputs for the program included the percent of impervious area in the subarea, the Soil Conservation Service (SCS) curve number, which was estimated from SCS soil maps and existing land uses, and the basin lag time. The HEC-1 model calculated peak discharges at 5 flow concentration points along the proposed channel route.

Hydraulic Analyses: The hydraulic analysis was conducted using the US ACE HEC-2 water surface profile computer program. The design discharges for various segments of the channel were those calculated using the HEC-1 model. A minimum of 1 foot of free board was assumed, and the top of road, top of bank, and channel invert elevations needed to develop cross-sectional input data was determined from maps, surveying notes, and road grading plans for the area. Other input parameters for the HEC-2 program were estimated, using the guidelines in the HEC-2 user's manual and independent hydraulic calculations, and included the Manning's "n" roughness coefficient and flow expansion and contraction coefficients. The analysis also assumed that there would be reinforced concrete box culverts placed at the road crossings and that the design would include a spreading basin at the terminus of the proposed channel. The purpose of the proposed spreading basin in the design was to reduce flow velocities, to spread flows such that the discharge to Mexico would occur in approximately the same area, to provide area for potential wetland mitigation, and to lessen the adverse aesthetic of a concrete channel. The results of the hydraulic analysis provided the optimal design of the main channel. The channel was designed as a concrete trapezoidal channel with a 2:1 slope.

Conclusions: The proposed channel would start at the south end of reinforced box concrete culverts under Otay Mesa Road just east of La Media Road, and then end with the spreading basin prior to discharge to Mexico. The proposed channel is approximately 7,570 feet (ft) long, with a width of 56 –

150 ft. The final 515 ft length of the channel would encompass the spreading basin, which would be approximately 600 ft wide. The spreading basin would be planted with natural riparian vegetation and would have a low-flow channel connecting the upstream concrete channel to the existing channel in Mexico.

August 9, 1999. Otay Mesa Drainage Study

This document provided an update to the 1988 Master Plan and identified a project that was compatible with new development plans for Otay Mesa and considered environmental constraints and alternative analyses.

Introduction: The goal of the document was to provide a primary drainage channel from Otay Mesa Road to the border with Mexico to accommodate runoff from existing and future development. Since the 1988 study, new channels, roads, development and detention basins had been constructed. The original project predicted construction of the channel described by 2005. The funding for the project was proposed to be collected from fees collected at the Final Map/ Building Permit approval for new developments.

Hydrologic Analysis: The new hydrologic analysis using the United States Army Corps of Engineers (US ACE) Hydraulic Engineering Center – HEC-1 model reflected runoff expected with new developments. The US ACE HEC-1 model was used, and the SCS method of analysis was used to estimate the rainfall on subareas with the study area. Guidance from the San Diego County Hydrology manual was used in providing required input for the program. The analysis derived subareas and flow concentration points based on existing drainage facilities, and where available, improvement plans for proposed facilities. If no improvement plan was available, the hydrologic criteria and drainage paths were based on assumptions of further development from master plans for the Mesa. The analysis included the proposed SR 905 and SR 125 freeways, and the proposed San Diego Air Commerce Center.

Hydraulic Analysis: Water surface profiles for the proposed channel were generated using the US ACE Hydraulic Engineering Center – River Analysis System (HECRAS), Version 1.2, a US ACE computer program. The HECRAS program determined steady state flow conditions based on user supplied cross section geometry and flow rates.

The slope of the proposed channel would be controlled by the gradual slope of the Mesa, the existing drainage facility located under Otay Mesa Road, and the channel elevation at the border. To convey the 100-year flood flow, the proposed channel would have to be very wide. A rectangular channel was recommended, as the rectangular shape carries the most flow per unit of area. The proposed rectangular channel would have a width of 40 ft across the inside bottom, plus wall width and channel access, such that the total width would be 55 ft. Any channel narrower and deeper than that proposed would possibly affect the ability of adjacent properties to properly drain. Existing sewer lines also constrained the depth of the proposed channel.

Environmental Constraints

Hydrologic: The future design of the Otay Mesa Master Drainage Plan would need to include future projects, including SR 905, SR 125, the Otay Mesa Road future realignment, and the Brown Field Airport. The project must meet the purpose and interest of the San Diego Environmentally Sensitive

Lands Ordinance. The channel design must also consider the effects of other planned projects in the vicinity and the concerns of the International Boundary and Water Commission (IBWC) regarding stormwater runoff rates. Permit requirements for the project would also likely include the use of soft bottom for the channel and incorporation of natural vegetation as much as possible, and demonstration that the project minimizes impacts to regional wildlife habitat.

Biological Resources: The Empire Center Mitigation Site, constructed in 1997 as part of a City, State and federal permitting action for an earlier project, included 5 acres of land in an area north of Airway Road and west of La Media Road and included over 12 created and naturally occurring vernal pools and habitat for San Diego button celery, a federally listed species. At least 14 vernal pools, encompassing approximately 25,756 ft², are located outside of the mitigation area. A patch of freshwater marsh was identified in the vernal pool restoration area. Mitigation at a probable ratio of 2:1 would be required to ameliorate any impacts to vernal pools and the freshwater marsh. Indirect effects to wetlands through changes in drainage patterns that could significantly affect their functionality would also possibly require mitigation.

Recommended actions for the Master Drainage Plan in reference to biological resources constraints included:

- Avoiding impacts to the Empire Centre Mitigation Site;
- Accurately mapping vernal pools with a survey crew in the spring;
- Avoiding impact to the vernal pools or concurrently mitigating impacts to the pools outside of the project site;
- Avoiding impacts to federally listed and narrow endemic plant species (i.e., San Diego celery-button, Otay tarplant, and variegated dudleya);
- Avoiding impacts to the San Diego Multi-Habitat Planning Area (MHPA);
- Including plans in the Master Drainage Plan to maintain low flow drainage patterns to avoid indirect effects on wetland habitats;
- Conduct surveys for burrowing owl burrows prior to development and impacts should be avoided or mitigated;
- Conduct protocol surveys for other potential federally listed species on the site;
- Mitigation of nonnative grassland at a ratio of 0.5:1.

Cultural Resources: Completion of a literature review and record searches at San Diego University and the San Diego Museum of Man was recommended for previously conducted archeological surveys.

Alternative Analyses

The objective of the alternatives analysis was to identify an alignment for the drainage channel that will efficiently convey the flows from an existing rectangular concrete box culvert under Otay Mesa Road to the U.S.-Mexico Border while minimizing impacts on environmentally sensitive areas and adjacent properties. The preferred alternative placed the channel along the east side of La Media to a box culvert crossing from the northeast corner to the northwest corner of the intersection of La Media with Siempre Viva Road. The channel continued along the north side of Siempre Viva from the box culvert outlet at La Media to a box culvert crossing to the south side of Siempre Viva to connect to the existing stream channel. This alternative was chosen as the preferred alternative because an existing drainage ditch is on the east side of La Media Road; the channel would intercept flows from

the east without potential conflicts from utilities in La Media Road; and flows from the west would continue to flow in the old drainage path. Additionally, the alternative minimizes impact on properties by following the property line and minimizes potential utilities conflicts in Siempre Viva Road by crossing under it through a box culvert at the existing stream location.

Possible funding mechanisms identified for funding the project included general obligation bonds, Mello-Roos Community Facilities Districts tax, special assessment bonds, and certificates of participation.

May 2005. Drainage Study for Otay Mesa Community Plan Update

The report was prepared as an appendix to the Otay Mesa Community Plan update EIR to provide a summary of existing drainage facilities and to provide alternatives for draining the Mesa. Most existing drainage facilities are located within East Watershed. The system existing at the time of the report was a combination of storm drains, improved channels, and detention basins, which discharge in many areas to natural drainage paths that do not have adequate hydraulic capacity. As many of the projects have been developed, portions of the properties have been dedicated to the city as drainage easements or flood water storage easements. These were presumably recorded as easements, however, this part of the Study was not verified.

Hydrologic Analysis: The Otay Mesa Drainage Study area included all of the Mesa area within the City of San Diego, divided into 5 watersheds (West Perimeter, West, North Perimeter, East, and Border Crossing), excluding the far northwest arm of the Mesa which had been fully developed. Most of Otay Mesa slopes from north to south with flow entering Mexico at several points. The perimeter of the Mesa drains into the adjacent canyons. The watershed boundaries on the Mesa are not well defined because the Mesa is flat, with stormwater run-off mostly sheet-flowing across the Mesa. Previous drainage study reports (1988, 1999) prepared hydrologic analyses for the East watershed. In the current report, new hydrologic models were developed using the HEC-1 model for the East watershed, since that was the hydrologic model previously used in analysis of the watershed. For the other main watersheds, West Perimeter and West, the AES-developed standard City of San Diego Modified Rational Method was used. The hydrologic analyses calculated that the total flow from these watersheds at the concentration point at the border for the 100-year flow was 5,793 cubic feet per second (cfs). The Spring Canyon open space in the West Watershed was calculated to contribute an additional 257 cfs.

Hydraulic Analysis: The HEC-RAS model was used to size the 100-year floodplain of Otay Mesa Creek based on current conditions. The model was also used to size the proposed new channel to contain the 100-year flow which would reduce or eliminate flooding impacts to nearby facilities. An existing channel that is tributary to the proposed main channel and located just upstream of the Siempre Viva Road Crossing is approximately 15 ft wide and 4 ft deep, with a hydraulic capacity of approximately 120 cfs. The 100-year flow in this channel however would be 1116 cfs. A new channel proposed for this tributary by this report is sized 50 ft wide with 1.5:1 side slopes to convey the 100 year flow. The cost estimate proposed by this report does not include this tributary channel.

Proposed Drainage Facilities: Caltrans had completed their plans for the SR-905 project. For proposed private development, the only Master Planned facility which would need to be constructed prior to

continued development is the Main Channel and the Detention Basin in the East Watershed. The Main Channel proposed by this report would have a bottom width of 240 ft at the Detention Basin to 200 ft from just north of Siempre Viva Road to the intersection of Airway Road and La Media Road. The side slopes would be 4:1 to 10:1 and heavy riparian vegetation would be allowed to grow in the channel. Hiking trails and access roads with a width of 12 feet would line each bank of the channel. At the Airway Road and La Media intersection, a 35 ft wide concrete channel would connect the channel with the proposed Caltrans culverts which would be constructed concurrently with SR 905.

The proposed Detention Basin was designed to attenuate peak flows from 5 year to 100 year storms, with dimensions of approximately 1700 ft by 1500 ft. The basin would encompass 58 acres with a maximum storage depth of 6.0 ft and a maximum storage volume of 308 acre-ft. The basin would be graded and vegetated to appear natural and to create a low flow stream. The basin and channel would require removal of 915,000 cubic yards of soil. It was assumed this soil would be used on adjacent properties to raise building pad grades.

A preliminary cost estimate was \$23,868,000 to complete the proposed project.

Recommended Drainage Design Criteria: The current study estimated that approximately 140 cfs will flow off of Otay Mesa into the West Perimeter Watershed. Detention basins were recommended for this watershed to reduce peak flows to predevelopment levels. Because of unstable soils in the area, placement of these detention basins and relocation of drainage facilities should be planned carefully to avoid an increase in soil instability and slope failure.

The West Watershed consists of smaller mesa-top watersheds that drain into the tributary canyons of Spring Canyon, which then flow into Mexico via the Spring Canyon concentration point. Detention basins were recommended in this watershed to reduce post-development peak flows to predevelopment levels. Care must be taken if detention basins concentrate flows at the upper edge of canyons so that erosion potential is not increased downstream.

Requirements have already been implemented in the East Watershed for control of peak runoff from development. The August 7, 1987 Notice provided requirements for individual developments to regulate stormwater such that runoff from developed properties did not increase above the runoff rate prior to development. The proposed single Detention Basin at the border would eliminate the need for individual on-site detention basins for subsequent development.

In the North Perimeter watershed, there were no identified peak flow attenuation requirements for the small watersheds that flow into small canyons that flow into the Otay River.

Stormwater Quality Requirements: The City requires Best Management Practices (BMPs) be constructed for all new projects. In 2003, the City published "Storm Water Standards – A Manual for Construction & Permanent Storm Water Best Management Practices Requirements", a reference document for all stormwater issues encountered in development. Most projects on Otay Mesa will require Priority Project Permanent Storm Water BMPs and High Priority Construction Storm Water BMPs. The manual requires the submission of a "Water Quality Technical Report" for all projects subject to priority permanent BMP requirements.

Most of Otay Mesa drains to the south across the U.S./Mexico border to the Tijuana River, which has been identified as an impaired water body pursuant to section 303(d) of the Clean Water Act. A small portion of the drainage flows north into the Otay River and the far western part of the Mesa flows to the west through San Ysidro and then into the Tijuana River.

April 2007. Drainage Study for the Otay Mesa Community Plan Update

The 2007 report was identical to the 2005 report, except for the addition of a section regarding the proposed drainage alternatives. This additional section is summarized below.

No Project Alternative: The alternative of doing nothing to improve drainage along the main creek channel would prevent future development from taking place along portions of La Media Road. The intersection of Airway Road and La Media Road floods during significant precipitation. The existing creek would not be deep enough to allow adjacent properties to drain effectively. To provide continued access along the truck route during storms the roads would need to be raised to allow flow to pass under them, or an alternative route would need to be identified.

Concrete Channel: The 1999 Otay Mesa Drainage Study identified a concrete channel as a recommended plan from Otay Mesa Road to the Border Detention Basin. The concrete channel would follow the east side of La Media Road until intersecting at Siempre Viva Road, where it crossed under La Media and followed on the north side of Siempre Viva to box culverts under Siempre Viva that connected to the Border Detention Basin. The concrete channel plan assumed that the existing creek with its habitat would continue to carry low flows. The 1999 cost for this project was \$10.6 million dollars, without including land acquisition costs, which corresponds to a 2005 cost of \$14.9 million.

La Media Channel and Border Detention Basin: The East Watershed is the largest watershed on the Mesa. All flows from the watershed collect at a concentration point at a large culvert where flows cross the U.S./Mexico border. The surrounding area is very flat and adjacent properties cannot drain effectively into the existing creek. To allow for future development, and to accommodate runoff from proposed future projects, a new channel would be required that has an invert of 3 to 5 feet below that of the existing creek channel. The proposed La Media Channel and Border Detention Basin would be built as described in the 2005 report.

C. Impetus of Drainage Studies

Tetra Tech was asked to provide as much detail as possible into the funding and motivation behind the drainage studies completed for Otay Mesa. It is well understood that the first report in 1988 was intended to provide drainage opportunities in the developing Otay Mesa area. The 1999, 2005, and 2007 reports all indicate the need for drainage planning in the rapidly developing Mesa area but also point to the need for water quality considerations and regulations, as well. Meeting regulatory requirements for flood and drainage control (1988) as well as water quality and environmental considerations (1999, 2005, and 2007) seem to be the initial motivation behind the reports.

The drainage reports provided little insight into the funding mechanisms supporting these studies. There were suggestions in several of the studies for funding mechanisms to implement the recommendations

within the studies including general obligation bonds, Mello-Roos Community Facilities Districts tax, special assessment bonds, and certificates of participation. Based on the direction of recommendations, the development community might have initiated the request for drainage control and improved drainage within the public right of way to accommodate drainage from developing areas. However, it is also quite possible that the motivation was also a part of a plan to design the public portion of the drainage system to fully accommodate a built out Otay Mesa that would provide the necessary public safety and flood control needs that a future fully developed scenario might require.

III. Data Compilation and Review

Plans and data including GIS data relevant to Otay Mesa study have been compiled for this report. Relevant drainage requirements and existing drainage plans for Otay Mesa area are summarized in the previous section. Using GIS data, drainage areas for the project site were defined and relevant spatial analyses have been conducted for each drainage area. Potential areas for restoring or improving vernal pools were identified using soil suitability, land uses, and site availability.

A. Data Compilation

The following data were compiled for this Otay Mesa study. Most of the data were downloaded from two websites, SanGIS (<http://files.sangis.org/>) and SANDAG (<http://www.sandag.org/>). Vernal pools data were supplied directly from the City.

- Otay Mesa community boundary (SanGIS)
- Zoning (SanGIS)
- Land use (SANDAG)
- Soils (SanGIS)
- Topography: 20-m DEM and 2-ft contours (SanGIS)
- Streams (SanGIS)
- Roads / Streets (SanGIS)
- Parcel boundaries (SanGIS)
- Watershed / Subwatershed boundaries (SanGIS)
- Vegetation (SanGIS)
- Existing vernal pools (City)

B. Drainage Areas

From the existing watershed/subwatershed data, three drainage areas were found in the Otay Mesa study area, which are Otay Valley, San Ysidro, and Water Tanks. Otay Valley covers north of Otay Mesa around the Otay River, San Ysidro covers west, and Water Tanks covers south of Otay Mesa. Otay Valley and Water Tanks were sub-divided into east and west areas respectively. As a result, the Otay Mesa area was divided into five drainages as shown in Figure 2. The sizes of drainage areas are presented in Table 1.

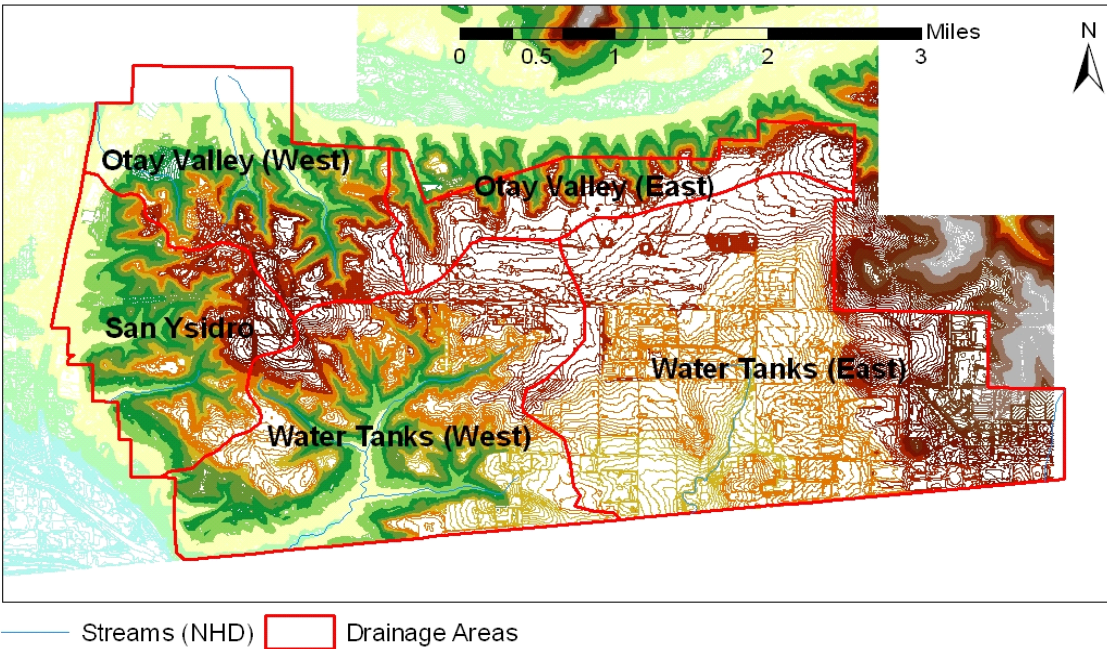

Figure 2. Defined Drainage Areas

Table 1. Drainage Area Sizes

Drainage Areas	Acres
Otay Valley (East)	827.5
Otay Valley (West)	1,378.4
San Ysidro	1,226.1
Water Tanks (East)	3,380.2
Water Tanks (West)	2,488.0
Total	9,300.2

C. Zoning Status

Existing zoning for the Otay Mesa is presented in Figure 3. Otay Mesa zoning consists of Industrial (41.2%), Agricultural (25.4%), Residential (12.2%), Commercial (4.8%), Open Space (0.2%), Other (4.8%), and Unzoned (11.4%) areas. The individual drainage area of each zone and total area is summarized in Table 2.

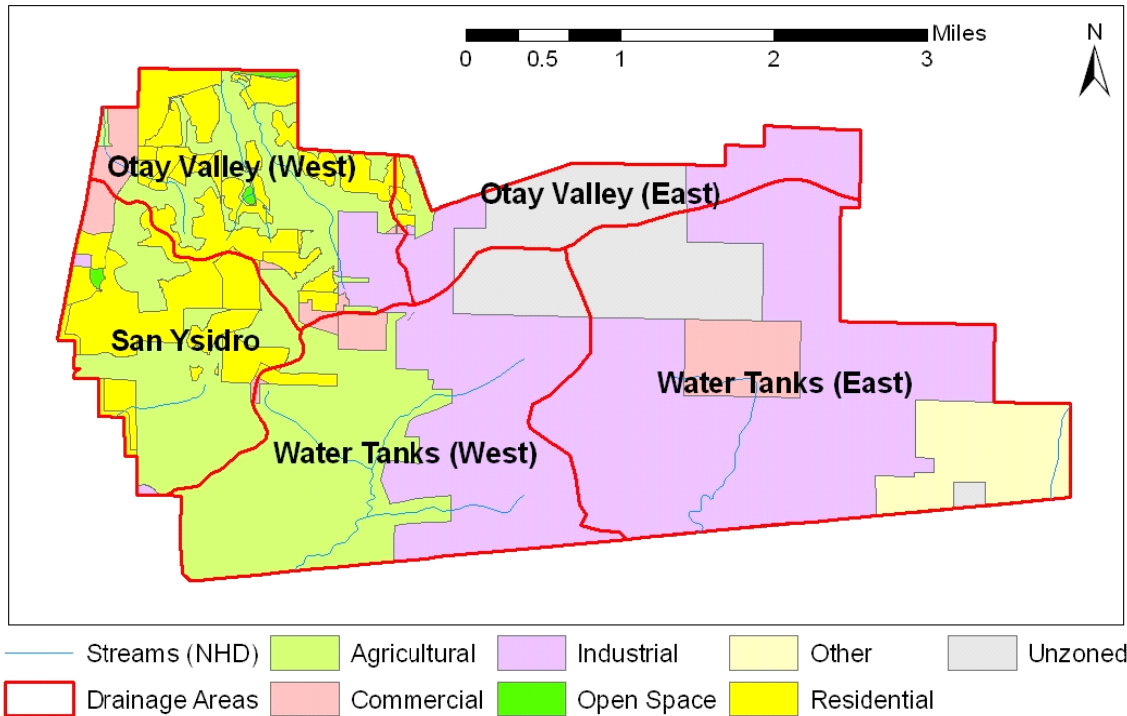

Figure 3. Zoning Status

Table 2. Zoning Status for Drainage Areas

Zoning	Drainage Areas					Total
	Otay Valley (East)	Otay Valley (West)	San Ysidro	Water Tanks (East)	Water Tanks (West)	
Agricultural	46.3	543.2	643.0	0.0	1,127.3	2,359.8
Commercial	0.7	100.2	43.2	241.5	61.5	447.0
Industrial	378.4	149.3	10.6	2,227.9	1,062.6	3,828.7
Open Space	0.0	15.1	5.9	0.0	0.0	21.0
Other	0.0	0.0	0.0	445.3	0.0	445.3
Residential	18.8	570.7	523.3	0.0	25.8	1,138.6
Unzoned	383.3	0.0	0.0	465.7	210.8	1,059.8
Total	827.5	1,378.4	1,226.1	3,380.3	2,488.0	9,300.2

D. Land Uses

Land use status for Otay Mesa is presented in Figure 4 using the 2009 SANDAG land use data set. The detailed land use status for each drainage area is summarized in Table 3. The Otay Mesa land uses consist of Open Space (28.8%), Undeveloped (25.4%), Transportation (21.5%), Industrial (12.1%), Residential (5.6%), Agricultural (3.3%), Commercial (2.1%), Education (1.0%), and Park (0.1%). Land use status appears quite different from the Otay Mesa zoning status. This might be because some areas within a particular zone are not fully developed or because the land use data have more detailed spatial descriptions, which consider topography that can impact land use, than the zoning data.

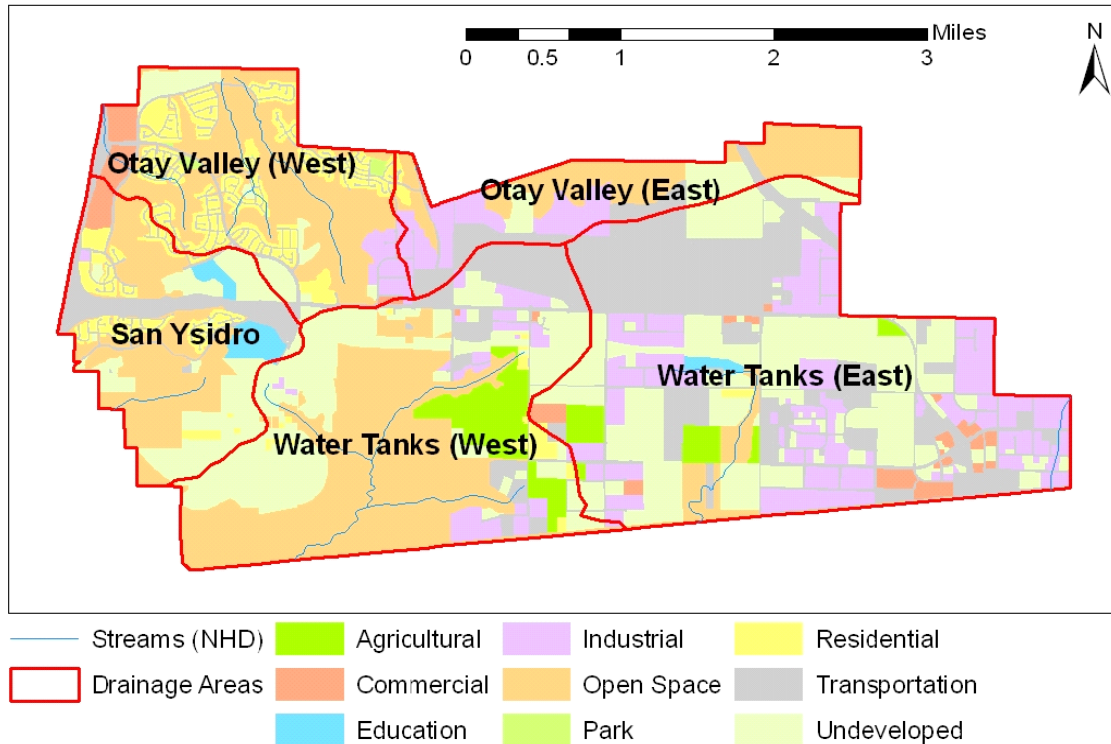

Figure 4. Land Uses

Table 3. Land uses for Drainage Areas

Land Use	Drainage Areas					Total
	Otay Valley (East)	Otay Valley (West)	San Ysidro	Water Tanks (East)	Water Tanks (West)	
Agricultural	0.0	0.0	0.0	101.6	204.3	305.9
Commercial	0.0	60.7	30.6	101.3	5.4	197.9
Education	0.0	0.0	70.1	17.6	0.7	88.4
Industrial	181.6	59.8	2.9	740.5	137.6	1,122.6
Open Space	377.3	629.0	461.2	133.1	1,081.3	2,681.9
Park	0.0	12.9	0.0	0.0	0.0	12.9
Residential	10.7	316.8	136.0	9.9	49.7	523.1
Transportation	146.5	190.0	227.0	1,148.0	290.1	2,001.7
Undeveloped	111.4	109.2	298.1	1,128.2	719.0	2,366.0
Total	827.5	1,378.4	1,226.1	3,380.2	2,488.0	9,300.2

E. Soils

Soil properties for the Otay Mesa are presented in Figure 5. Soil coverage for each drainage area is summarized in Table 4. Otay Mesa is covered mainly by loam (81.2%) and clay (18.0%) type soils.

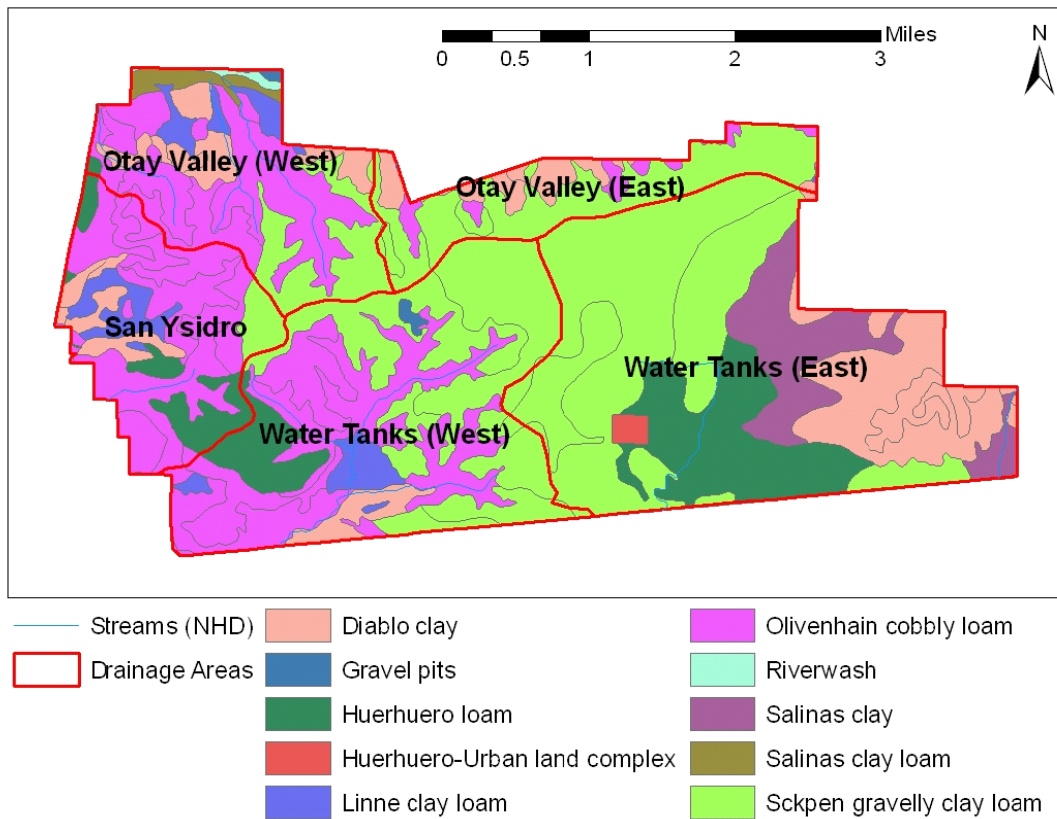

Figure 5. Soils

Table 4. Soils for Drainage Areas

Soils	Drainage Areas					
	Otay Valley (East)	Otay Valley (West)	San Ysidro	Water Tanks (East)	Water Tanks (West)	Total
Diablo clay	149.8	196.0	121.3	635.1	98.0	1,200.1
Gravel pits	0.0	8.6	0.0	0.0	15.7	24.3
Huerhuero loam	0.0	6.9	174.7	606.4	182.4	970.4
Huerhuero-Urban land complex	0.0	0.0	0.0	31.4	0.0	31.4
Linne clay loam	1.5	93.2	111.1	0.0	105.9	311.7
Olivenhain cobbly loam	83.0	714.0	742.3	0.0	989.7	2,529.1
Riverwash	0.0	17.8	0.0	0.0	0.0	17.8
Salinas clay	0.0	0.0	0.0	474.1	0.0	474.1
Salinas clay loam	0.0	71.3	0.0	0.0	0.0	71.3
Stockpen gravelly clay loam	593.1	270.7	76.7	1,633.2	1,096.2	3,670.1
Total	827.5	1,378.4	1,226.1	3,380.2	2,488.0	9,300.2

F. Vegetation

Vegetation coverage for Otay Mesa is presented in Figure 6. The size of vegetation coverage for each drainage area is summarized in Table 5. Otay Mesa vegetation consists mostly of non-native vegetation or developed/unvegetated areas (70.6%), scrub and chaparral (18.9%), grasslands and meadows (10.2%), and other areas (0.4%).

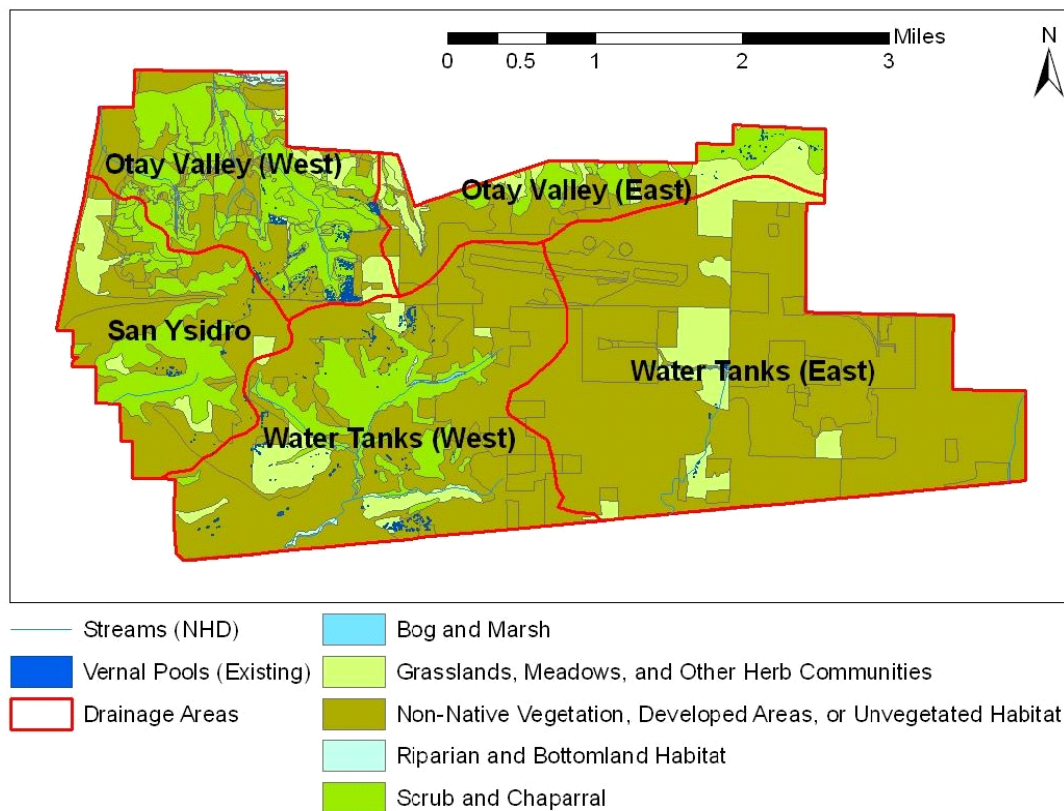

Figure 6. Vegetation of Otay Mesa

Table 5. Vegetation Coverage for Drainage Areas

Vegetation	Drainage Areas					
	Otay Valley (East)	Otay Valley (West)	San Ysidro	Water Tanks (East)	Water Tanks (West)	Total
Bog and Marsh	0.0	0.8	0.0	0.0	4.0	4.8
Grasslands, Meadows, and Other Herb Communities	205.1	88.6	112.0	341.0	201.8	948.5
Non-Native Vegetation, Developed Areas, or Unvegetated Habitat	394.2	528.9	720.2	3,039.2	1,883.4	6,565.9
Riparian and Bottomland Habitat	0.0	17.6	0.2	0.0	8.6	26.4
Scrub and Chaparral	228.2	742.5	393.7	0.0	390.2	1,754.7
Total	827.5	1,378.4	1,226.1	3,380.2	2,488.0	9,300.2

IV. Environmentally Sensitive Lands

A. Vernal Pool Background

Vernal pools are unique seasonal and ephemeral wetlands that result from specific depression-type geomorphic regions. (City of San Diego Vernal Pool Inventory, 2004) Vernal pools form when small, shallow depressions collect precipitation, and by nature are dry basins in the dry months followed by variable lengths of saturation and inundation. [Draft City of San Diego Multiple Species Conservation Program (MSCP) Vernal Pool Management Plan, 2008] The variability in moisture conditions separates these pools from other wetland ecosystems, which is a characteristic of the Mediterranean –type climate that exists in southern California.

Within the City of San Diego, groups or series of vernal pools are found in Del Mar Mesa, Mire Mesa, Carmel Mountain, Kearny Mesa, Mission Trails Regional Park, Otay Mesa, Otay Lakes, and Marron Valley. The pools are often associated with small hills known as Mima mounds, and form in the inter-mound swales. The vernal pools located in these areas have been found to be associated with the particular soil types in these areas. (Bauder and McMillan, 1998) In Otay Mesa, Stockpen, a gravelly clay, is the dominant type of pool-supporting soil, as identified from the county's 1973 Soil Survey maps, with the type of vernal pools associated with this soil called Coastal Mesa pools. Coastal mesa pools are found almost exclusively on the mesas but sustain different flora and fauna depending on the dominant soil series.

Vernal pools support a specific biological ecosystem. Research has found that 47 plant species from 20 families are restricted to vernal pool habitat. (Draft San Diego MSCP Vernal Pool Management Plan, 2008) Vernal pool habitat also supports animals from insect larvae to amphibians, birds, and mammals. San Diego vernal pools provide habitat for two federally listed endangered invertebrates, San Diego and Riverside fairy shrimp; five federally listed endangered plants, spreading navarretia, San Diego and Otay mesa mint, San Diego button celery, and California Orcutt grass; and an unprotected, although rare, plant, little mousetail. *Pogogyne nudiuscula* is a mesa mint species endemic to the coastal mesa pool type of Otay Mesa.

Ecological processes that occur within vernal pools are complex, and not fully understood. Local processes are affected by the relatively short period of wet conditions and relatively small affected area (Leidy and White, 1998). The ecology of the vernal pool is also influenced by larger-scale effects of the watershed including landscape processes of stormwater run-off and native and invasive vegetation. Vernal pools and their associated wetland functions may be indirectly impacted by changes in the watershed, especially changes in hydrologic conditions which need to be considered when development or other landscape changes occur.

B. Otay Mesa Vernal Pools

Within Otay Mesa, the number and quality of vernal pools has been impacted historically by farming and grazing, and more recently, by rapid development in the area. Vernal pool surveys in the San Diego area have been conducted since the late 1970s. In 1988, the California Department of Parks and Recreation estimated that approximately 905 of the Otay Mesa vernal pools had been lost to urban development, agriculture and mining (Leidy and White, 1998). The most recent survey was conducted by the City of San Diego in 2002 – 2003 (City of San Diego Vernal Pool Inventory 2002 – 2003, 2004). This survey identified 29 series, or clusters, of vernal pool basins within the Otay Mesa area, and a total of 983

basins. The survey also identified a total of 12.89 acres of pools that were under creation, enhancement or restoration activities.

The Draft San Diego MSCP Vernal Pool Management Plan identified several factors that should be considered in management and preservation of vernal pools, with urban development identified as the primary threat to these ecosystems. Border Patrol activities along the U.S./Mexico border have caused impacts to Otay Mesa vernal pools because of foot traffic of illegal immigrants and Border Patrol agents. Recreational off-road vehicle users, illegal dumping and littering have also lead to vernal pool impacts. Disturbance and fragmentation of native habitat have resulted in vernal pool ecosystem impacts.

Recommendations for management of vernal pool resources have been implemented at the City and federal level. The 2008 draft San Diego MSCP Vernal Pool Management Plan includes site-specific management requirements and general recommendations for multiple vernal pool complex locations in Otay Mesa. These recommendations include conservation, enhancement or restoration of degraded basins through government implementation, project mitigation requirements, and/or interested non-governmental organizations. The document also recommended research on vernal pool plant genetics, native pollination and dispersal mechanisms to better understanding of vernal pool functions. Also, public education efforts are recommended to increase awareness of vernal pools. The City prioritized the following recommendations:

1. Conservation of land comprising the vernal pool site(s) through government or private land trust acquisition, dedication in fee title, conservation easement, or covenant of easement.
2. Adequate protection of conserved vernal pools from illegal and inadvertent impacts by fencing the site, placing signs, and providing education and/or law enforcement patrol of the sites.
3. Enhancement or restoration of vernal pools to reinstate historic ecosystem functions and values.
4. Solicit and fund, if possible, research on vernal pool ecosystems.

The recommendations provided by the Vernal Pool Management Plan may be enforceable by regulatory agencies through permit conditions, approved mitigation, monitoring and reporting programs, a Biological Opinion resulting from a Section 7 consultation with the U.S. Fish and Wildlife Service (FWS), and development agreement(s).

The U.S. FWS first provided a vernal pool recovery plan for southern California in 1998, and again in 2005. The more recent plan addressed 33 species of plants and animals that occur exclusively or primarily within a vernal pool ecosystem in California, with the ultimate goal of achieving and protecting self-sustaining populations of each species, through stabilizing and protecting populations to prevent further decline. (U.S. FWS, 2005) The key elements included in the plan for achieving these goals were habitat protection; adaptive management, restoration and monitoring; status surveys; and research.

U.S. EPA has also provided recommendations for vernal pool compensation and conservation (Leidy and White, 1998). In light of the complex system of processes that occur within vernal pool ecosystems, and the relationship of these niches to the larger watershed, U.S. EPA recommended using an ecosystem approach in assessing vernal pool compensation. The ecosystem approach would base compensation on preservation of vernal pool complexes within *an ecosystem* rather than the current approach of creating or restoring isolated pools. A hydrogeomorphic approach to assessing wetland function was

recommended to provide the most efficient method to determine mitigation requirements for impacted vernal pools (Leidy and White, 1998).

V. Review of Stormwater Regulations

A. Federal Regulations and Permits

CWA Section 404 Permits

Most projects conducted in or adjacent to streams or wetlands will require a U.S. Army Corp of Engineers (US ACE) Clean Water Act (CWA) Section 404 Permit. A Section 404 Permit is required if materials, including dirt, rocks, geotextiles, concrete, or culverts, are moved or placed into or within US ACE jurisdictional areas. Permit coverage may be granted if the following are performed: (1) actions are taken to avoid wetland impacts, (2) potential impacts are minimized, and (3) compensation for any unavoidable impacts is provided.

Proposed activities are regulated through a permit review process. An individual permit is required for potentially significant impacts. Individual permits are reviewed by the US ACE and evaluated under a public interest review, as well as the environmental criteria set forth in the CWA Section 404(b)(1) Guidelines. However, for most discharges that will have only minimal adverse effects, a general permit may be suitable. The Section 404 general permit process is more streamlined than the individual permit process due to the elimination of the individual review, provided that the general or specific conditions for general permit coverage are met. General permits are issued on a nationwide, state, or regional basis for particular categories of activities.

- Regional General Permits (RGPs) are issued for common maintenance-type activities with minimal impact to the environment and often include pre-approval from the RWQCB Section 401 Certification and/or from the U.S. Fish and Wildlife Service (FWS) and NOAA Fisheries Service for Endangered Species Act consultations. Permit coverage takes approximately one to six months for existing activity categories or six months to one year for new and unique activity categories.
- Nationwide Permits (NWP) are written for categories of projects that occur nationwide, such as road crossings, bank stabilization, repairs to existing structures, flood control maintenance, and wetland restoration for wildlife habitat. Permit coverage takes from three to nine months.
- An Individual Permit (IP) may be required if over one-half acre of permanent impacts may occur. Public review is required for an IP, which lengthens the amount of time between permit application and permit coverage (six months to a year under the best circumstances, but can be multiple years).

The 404 Permit process should begin with a consultation with US ACE. Prior to application for a Section 404 Permit, a wetland delineation and estimation of US ACE jurisdictional area should be performed. RWQCB 401 Water Quality Certification must also be obtained when applying for a NWP or IP. After any pre-application steps are completed, the US ACE "Application for Department of the Army Permit" should be prepared and submitted.

The US ACE Section 404 permit also requires that a Section 106 Review be conducted as part of the permit application. Section 106 is a document review of the project site for historical significance. Based on the results, additional studies may be required, such as an additional Historical/Archaeological Report or mitigation to protect the historical significance of the site. The review search and approval duration varies on the project scope.

Endangered Species Act

Impacts to endangered or threatened species are regulated under both the California Endangered Species Act (CESA) administered by CA Department of Fish and Game (DFG) and the federal Endangered Species Act (ESA) administered by US Fish and Wildlife Service (FWS). Species that are protected under these laws are designated on the state and federal endangered and threatened species lists. The term “take” is used to describe the impact to a species. Under Section 2081 of the DFG code, a development project that coincides with the occurrence of a listed species must have an incidental take permit. To obtain this permit, the applicant must meet the following criteria (California Department of Fish and Game, 2009):

1. The authorized take is incidental to an otherwise lawful activity
2. The impacts of the authorized take are minimized and fully mitigated
3. The measures required to minimize and fully mitigate the impacts of the authorized take are roughly proportional in extent to the impact of the taking on the species, maintain the applicant’s objectives to the greatest extent possible, and are capable of successful implementation.
4. Adequate funding is provided to implement the required minimization and mitigation measures and to monitor compliance with and the effectiveness of the measures
5. Issuance of the permit will not jeopardize the continued existence of a State-listed species.

A mitigation plan is attached to a permit that outlines how these criteria will be met. Measures for meeting the criteria vary and may include avoidance measures or acquisition and transfer of habitat management lands (including funds for protecting and maintaining land in perpetuity). Applicants must avoid all take for “fully protected” species and “specified birds” as defined in Fish and Game Code Sections 3505, 3511, 4700, 5050, 5515, and 5517 (<http://www.leginfo.ca.gov/cgi-bin/calawquery?codesection=fgc&codebody=&hits=20>). All take of bird species protected under the Migratory Bird Treaty Act must also be avoided, as stated in Section 3515 of the DFG code.

An applicant determines whether an incidental take permit and a Habitat Conservation Plan (HCP) are required by contacting the nearest DFG. The potential need for a permit can be assessed by using the DFG’s online mapping resources. If a listed species is present on the property and the project will result in a take of that species, then a permit is required. Permit processing is likely to take between 3 and 12 months or longer depending on the project circumstances and whether a federal permit is required.

To meet federal ESA requirements for a take of federally listed species, an incidental take permit (http://www.dfg.ca.gov/habcon/cesa/incidental/CodeRegT14_783.pdf) must also be obtained by developing a HCP that outlines plans to offset impacts to the species listed as threatened or endangered (<http://www.fws.gov/Endangered/wildlife.html>). HCP must meet the following criteria:

1. Taking will be incidental
2. The applicant will, to the maximum extent practicable, minimize and mitigate the impacts of the taking
3. The applicant will ensure that adequate funding for the plan will be provided
4. Taking will not appreciably reduce the likelihood of the survival and recovery of the species in the wild
5. Other measures, as required by the Secretary, will be met.

Mitigation measures for ESA, like measures for CESA, vary by the project and may include the following:

- Payment into an established conservation fund or bank
- Preservation (via acquisition or conservation easement) of existing habitat
- Enhancement or restoration of degraded or a former habitat
- Establishment of buffer areas around existing habitats
- Modifications of land use practices and restrictions on access.

An applicant determines whether an incidental take permit and HCP are required by contacting the nearest DFG or FWS office. If a listed species is present on the property and the project will result in a take of that species, then a permit is required.

Under ESA, an incidental take permit is not required for plant species. However, if a permit is required for other endangered or threatened species and an HCP must be prepared, then the HCP must analyze the effects of the action on any endangered or threatened plant species. Accordingly, if a plant is on the California threatened or endangered list, then a permit must be obtained through DFG.

The timeline for federal incidental permit processing varies by project complexity and whether FWS must require National Environmental Policy Act (NEPA) documentation. Minor, or "Low Effect," HCPs do not require FWS to prepare NEPA documentation, and the target processing time for these HCPs is three months. HCPs that require an Environmental Assessment (EA) under NEPA have a target processing time of four to six months, and for HCPs requiring an Environmental Impact Statement (EIS), processing may take up to 12 months or longer (U.S. Fish and Wildlife Service, 2005).

A Section 7 Consultation may also be required under the ESA if the project has a "federal nexus," usually in the form of another federal permit or federal funding, at some stage of the project and with any federal agency. The type of consultation will be either informal or formal, depending on whether the project affects listed or protected species. If the project has a federal nexus, it will also require NEPA documentation, which is described under the federal requirements section of this report.

Data on endangered and threatened species observations are available from the California Natural Diversity Database, which is developed by the Biogeographic Data Branch of DFG, and these data estimate the approximate spatial range of the species.

B. State Regulations and Permits

California Endangered Species Act (CESA)

CESA states that all native species of fishes, amphibians, reptiles, birds, mammals, invertebrates, and plants, and their habitats, threatened with extinction and those experiencing a significant decline which, if not halted, would lead to a threatened or endangered designation, will be protected or preserved (California Department of Fish and Game, no date). Sections 2081(b) and (c) of CESA allow the California DFG to issue an incidental take permit for a State listed threatened and endangered species only if specific criteria are met. These criteria are as follows:

- The authorized take is incidental to an otherwise lawful activity;
- The impacts of the authorized take are minimized and fully mitigated;
- The measures required to minimize and fully mitigate the impacts of the authorized take are roughly proportional in extent to the impact of the taking on the species, maintain the applicant's objectives to the greatest extent possible, and are capable of successful implementation;
- Adequate funding is provided to implement the required minimization and mitigation measures and to monitor compliance with and the effectiveness of the measures; and
- Issuance of the permit will not jeopardize the continued existence of a State-listed species.

Measures to minimize the take of species covered by the permit and to mitigate the impacts caused by the take will be set forth in one or more attachments to the permit. Incidental Take Permit Applications include the following (California Department of Fish and Game, 2008):

1. Applicant's full name, mailing address, and telephone number(s).
2. The common and scientific names of the species to be covered by the permit and the species' status under CESA, including whether the species is the subject of rules and guidelines pursuant to Section 2112 and Section 2114 of the Fish and Game Code.
3. A complete description of the project or activity for which the permit is sought.
4. The location where the project or activity is to occur or to be conducted.
5. An analysis of whether and to what extent the project or activity for which the permit is sought could result in the taking of species to be covered by the permit.
6. An analysis of the impacts of the proposed taking on the species.
7. An analysis of whether issuance of the Incidental Take Permit would jeopardize the continued existence of a species. This analysis includes consideration of the species' capability to survive and reproduce, and any adverse impacts of the taking on those abilities in light of (a) known population trends; (b) known threats to the species; and (c) reasonably foreseeable impacts on the species from other related projects and activities.
8. Proposed measures to minimize and fully mitigate the impacts of the proposed taking.
9. A proposed plan to monitor compliance with the minimization and mitigation measures and the effectiveness of the measures.
10. A description of the funding source and the level of funding available for implementation of the minimization and mitigation measures.
11. Certification of accuracy.

California Environmental Quality Act (CEQA)

CEQA requires environmental impact assessment and mitigation for non-exempt projects occurring within the State of California. As unique ecosystems associated with endangered and threatened species, vernal pools are considered rare biological resources in CEQA review. CEQA applies to projects proposed to be undertaken or requiring approval by State and local government agencies. The lead agency is responsible for completing an environmental review process defined by CEQA. The review process includes

1. Determining if the activity is a project subject to CEQA,
2. Determining if the project is exempt from CEQA, and
3. Performing an Initial Study to identify the environmental impacts of the project and determine whether the identified impacts are “significant.” Based on the findings of significance, one of the following documents must be prepared:
 - Negative Declaration if the review finds no “significant” impacts;
 - Mitigated Negative Declaration if the review finds “significant” impacts but the project can be altered to avoid or mitigate those significant impacts;
 - Environmental Impact Report (EIR) if the review finds “significant” impacts.

Some projects may be determined to be exempt from CEQA by law because the project may fall under a category of projects that have already been determined to generally not have significant environmental impacts. Examples include resource and environmental protection actions by regulatory agencies, wildlife habitat acquisition, habitat restoration on five acres or less, maintenance activities, or emergencies. Retrofits to existing structures may be considered an exception. Articles 18 (<http://ceres.ca.gov/ceqa/guidelines/art18.html>) and Article 19 (<http://ceres.ca.gov/ceqa/guidelines/art19.html>) of the Act contain details on exemptions and exceptions to CEQA.

This project may require consideration of cultural resources as part of CEQA documentation. The purpose of a cultural resources study is to identify significant impacts and potentially significant impacts of a proposed project to cultural resources, and to provide mitigation measures to reduce impacts to a level less than significant.

401 Certification

Under CWA Section 401, every applicant for a federal permit or license for any activity which may result in a discharge to a water body must obtain State Water Quality Certification (401 Certification) to ensure the proposed activity will comply with state water quality standards. In general, a 401 Certification is required for all projects in which a US ACE CWA Section 404 Permit (described above) is obtained or that will discharge dredged or fill material to waters of the U.S., including removing vegetation or channel materials for flood control, constructing levees, and filling wetlands. If the Regional Water Quality Control Board (RWQCB) deems a project exempt from the provisions of Section 401, it may regulate the dredge and fill activity under State authority in the form of Waste Discharge Requirements or Certification of Waste Discharge Requirements.

To initiate the 401 Certification process, a Biological Assessment is typically performed in which any potential impact to waters of the U.S., adjacent wetlands, and receiving waters is determined. Coordination between the City and the RWQCB is recommended before the application is submitted. A *Section 401 Water Quality Certification Application Form* should then be prepared and submitted to the RWQCB. On average, the 401 Certification application process takes three to four months to complete from the time of application to the time of approval.

C. Local Regulations and Permits

Post-Construction Stormwater Management

For typical development projects, the City requires project proponents to use a checklist to determine whether standard stormwater requirements (low impact development and source controls) or priority stormwater requirements (for development that meets certain size or land use thresholds or that might impact sensitive areas) are applicable. The Stormwater Standards Manual describes the steps that then need to be taken (i.e., Best Management Practices, or BMPs) to meet the applicable requirements. These stormwater requirements are not likely to apply to a drainage project.

Project proponents are required to submit Urban Stormwater Mitigation Plans consistent with the region's Standard Urban Stormwater Mitigation Plan (<http://www.sdcountry.ca.gov/dpw/watersheds/susmp/susmp.html>) to meet the following objectives:

- Reduce Priority Development Project discharges of pollutants from the MS4 to the maximum extent practicable
- Prevent Priority Development Project runoff discharges from the MS4 from causing or contributing to a violation of water quality standards
- Manage increases in runoff discharge rates and durations from Priority Development Projects that are likely to cause increased erosion of stream beds and banks, silt pollutant generation, or other impacts to beneficial uses and stream habitat due to increased erosive force.

Some areas within Otay Mesa could be considered a Priority Development Project Areas if they were to discharge runoff from any development or redevelopment directly into or directly adjacent to receiving waters within an Environmentally Sensitive Area (ESA; includes vernal pools). Other conditions that would trigger the application of a priority development project area include either the creation of 2,500 square feet of impervious surface on a proposed project site or an increase in the area of imperviousness of a proposed project site to 10 percent or more of its naturally occurring condition (San Diego Regional Water Board Order R9-2007-0001 (Section D.1.d.(2)(g))). Within these definitions, "directly adjacent" is defined as project sites situated within 200 feet of the ESA. "Discharging directly to" is defined as outflow from a drainage conveyance system that is composed entirely of flows from the subject development or redevelopment site, and not commingled with flows from adjacent lands.

Provision D.1.g of San Diego Regional Water Board Order R9-2007-0001 requires the San Diego Stormwater Copermittees to implement a Hydromodification Management Plan (HMP) "...to manage increases in runoff discharge rates and durations from all Priority Development Projects, where such increased rates and durations are likely to cause increased erosion of channel beds and banks, sediment pollutant generation, or other impacts to beneficial uses and stream habitat due to

increased erosive force.” To comply with this requirement, the San Diego Copermittees developed an HMP (http://www.projectcleanwater.org/pdf/susmp/hmp_final_12-29-09_clean.pdf, December 29, 2009), which is subject to Regional Water Quality Control Board approval. The HMP specifies that Priority Development Projects are required to implement hydromodification mitigation measures so that post-project runoff flow rates and durations do not exceed pre-project flow rates and durations where such increases would result in an increased potential for erosion or significant impacts to beneficial uses. Hydromodification mitigation can be provided as follows:

- Demonstrate no post-project increase in impervious area and resultant peak flow rates as compared to pre-project conditions
- Installation of LID BMPs, such as bioretention facilities, to control runoff flows and durations from new impervious areas
- Mitigation of flow and durations through implementation of extended detention flow duration control basins
- Preparation of continuous simulation hydrologic models and comparison of the pre-project and mitigated post-project runoff peaks and durations (with hydromodification flow controls) until compliance is achieved
- Implementation of in-stream rehabilitation controls to demonstrate that projected increases in runoff peaks and/or durations would not accelerate erosion to the rehabilitated receiving stream reach.

Chapter 6 of the HMP Guidance provides guidance on applicability, hydromodification mitigation criteria and implementation options, and a framework for in-stream rehabilitation options.

Construction Stormwater Management

In California, discharges from construction sites one acre or larger are regulated under the State-wide General Permit for Waste Discharge Requirements for Discharges of Storm Water Associated with Construction Activity (NPDES General Permit CAS000002) Water Quality Order 98-08-DWQ (General Permit). The General Permit requires a Storm Water Pollution Prevention Plan (SWPPP) that describes BMPs to prevent pollutant and sediment discharges from the construction site, as well as an inspection and monitoring program. A Notice of Intent (Attachment 2 of the General Permit) is to be submitted to the State Water Resources Control Board (SWRCB) along with a project site map and fee at least two weeks prior to construction initiation.

The SWPPP must remain onsite at all times and regular self-inspections must be performed to assess the effectiveness of the BMPs. Stormwater samples must be collected if there is reason to suspect that non-visible pollutants have come into contact with stormwater or the site discharges to a water body listed on the 2006 CWA Section 303(d) List of Water Quality Limited Segments Requiring TMDLs. If permit coverage is not terminated within a year, an annual report must be completed and submitted to the LARWQCB. To terminate permit coverage, a Notice of Termination is to be completed and submitted to the SWRCB. The Construction Storm Water General Permit is currently under revision and is available online at:

http://www.waterboards.ca.gov/water_issues/programs/stormwater/constpermits.shtml.

Biological Resources

Multi-Species Conservation Program

The Multi-Species Conservation Program (MSCP) applies to the Otay Mesa area. The MSCP is designed to preserve native habitat for multiple species by identifying areas for directed development and areas to be conserved in perpetuity (referred to as Multi-Habitat Planning Area or MHPA) to achieve a workable balance between smart growth and species protection. The project area falls within portions of the City's MHPA and includes areas directly adjacent to the MHPA. These two categories have different requirements as follows:

- For **premises that are located within or adjacent the City's MHPA**, the project must demonstrate compliance with the MHPA land use adjacency guidelines (see the City's MSCP Subarea Plan, March 1997, <http://www.sandiego.gov/planning/mscp/pdf/subarea.pdf>) to address potential indirect effects to the MHPA through features incorporated into the project and/or permit conditions. The following issue areas are addressed:
 1. Drainage;
 2. Toxics;
 3. Lighting;
 4. Noise;
 5. Barriers;
 6. Invasive species;
 7. Brush management; and,
 8. Grading/land development.
- For **sites partially within the MHPA**, the allowable development area under the MSCP includes all the land outside the MHPA. If less than 25 percent is outside the MHPA, the project would be allowed the required area to achieve a 25 percent development area. In defining the 25 percent developable area, the least sensitive portion of the site must be used and would include avoidance/minimization of wetlands and MSCP narrow endemics.

The MHPA can be altered on a site to accommodate a project, subject to approval by the City and wildlife agencies in accordance with meeting the six MHPA boundary line adjustment functional criteria (see Section 5.4.2 of the Regional MSCP Plan, August 1998, <http://www.co.sandiego.ca.us/dplu/mscp/docs/SCMSCP/FinalMSCPPProgramPlan.pdf>). These criteria include:

- Effects on significantly and sufficiently conserved habitats;
- Effects to covered species;
- Effects on habitat linkages and function of preserve areas;
- Effects on preserve configuration and management;
- Effects on ecotones of other conditions affecting species diversity; and
- Effects to species of concern not on the covered species list.

The analysis for any proposed MHPA adjustment should be included in the project biology report¹ (if required, see below), and include:

1. An exhibit clearly showing the proposed removal and addition areas with the proposed grading;
2. A table showing, by habitat type, area within the existing MHPA, area to be removed, area to be added, and the proposed net change to the preserve; and
3. A written analysis of how the proposed MHPA adjustment meets the six required functional equivalency criteria.

Environmentally Sensitive Lands (ESL) Regulations

The City oversees development that may impact listed species through the ESL Regulations (San Diego Municipal Code, Land Development Code, and Biology Guidelines, currently pending amendment). City public projects do not need a grading permit, however these projects will still be required to obtain all necessary City, State, and Federal permits prior to the preconstruction meeting or any clearing or grading of the project site.

Land Development Code Biology Guidelines (City of San Diego, 2001) lists *Eryngium aristulatum* var. *parishii* (Parish's eryngo, San Diego button celery), *Navarretia fossalis* (spreading navarretia, vernal pool pincushionplant), *Orcuttia californica* (California Orcutt grass), *Pogogyne abramsii* (San Diego mesa mint), and *P. nudiuscula* (Otay Mesa mint) as narrow endemic species. Narrow endemics are included in the definition of Environmentally Sensitive Lands, which requires a discretionary review of the project permit including biological surveys and species specific mitigation requirements. These species are associated with vernal pool habitats, which are found within the project area (see Section Vernal Pool Management Plan, below, for more information about vernal pool management).

A biological survey report is required for all proposed development projects that are subject to the ESL Regulations, and/or where CEQA review has determined that there may be a significant impact on other biological resources considered sensitive under CEQA. Table 6 summarizes survey requirements for various biological resources inside and outside the MHPA. Note that the proposed project site includes areas that are inside, adjacent to, and outside of the MHPA area.

The Biological Survey Report must identify all potential impacts from the development (both on-site impacts and off-site impacts such as roads, water and sewer lines) to sensitive biological resources and to other significant biological resources as determined by the CEQA process. The report should evaluate the significance of these impacts. Impact assessments need to include analysis of direct impacts (e.g. grading, Zone 1 brush management), indirect impacts (e.g. lighting, noise) and cumulative impacts. The City of San Diego (1994) Significance Determination Guidelines under the CEQA should be used as a reference.

The ESL regulations require that impacts to wetlands be avoided, and all unavoidable wetlands impacts (both temporary and permanent) will need to be analyzed and mitigated via wetland creation, restoration, enhancement, and/or acquisition. Acquisition and/or enhancement of existing wetlands

¹ Three full sets of the MHPA adjustment materials will be required for any proposed MHPA adjustment.

may be considered as partial mitigation only. The mitigation ratio for vernal pools ranges from 2:1 when no endangered species are present, up to 4:1 when endangered species with very limited distributions (e.g., *P. abramsii*) are present.

Table 6. Summary of biological survey requirements

Resource	Survey Requirements	
	Inside MHPA	Outside MHPA
<i>Vegetation</i> Uplands Wetlands	Confirm/Revise MSCP mapping Delineate wetlands per City definition	Confirm/Revise MSCP mapping Delineate wetlands per City definition
<i>Covered species</i> ¹ Listed species Narrow endemic Other	Focused survey per protocol Focused survey per protocol Survey as necessary to comply with requirements as outlined in Section II.A.2 of Biology Guidelines	Per MSCP conditions of coverage ² Focused survey per protocol Per MSCP conditions of coverage ²
<i>Non-covered species</i> Listed species "Other sensitive species" ³	Focused survey per protocol Case-by-case determination depending on the species	Focused survey per protocol Case-by-case determination depending on the species

1. Based upon the MSCP mapping, site specific surveys, the NDDDB records, previous EIRs and biological surveys and/or discussion with the Wildlife Agencies, the potential for listed species, narrow endemic and CEQA sensitive species will be determined. Where there is a reasonable likelihood that one of these species exists, surveys will follow the above requirements.
2. Survey as necessary to conform with to Appendix A of the City of San Diego MSCP Subarea Plan (March 1997).
3. "Other Sensitive Species". Those other species that are not listed by federal and/or state agencies and/or not covered by the MSCP and to which any impacts may be considered significant under CEQA.

Vernal Pool Management Plan

To protect vernal pools, site-specific management recommendations were developed for ten Otay Mesa locations (<http://www.sandiego.gov/planning/mscp/vpmp/index.shtml>), two of which occur in the project area: "J28 East" and "J21." J 28 East is a 20-acre site located southwest of the intersection of La Media Road and Avenida de la Fuente with five mapped vernal pools that are located within the MHPA. J21 is a 49-acre site located southwest of Siempre Viva Road and La Media Road with seven vernal pools that are located outside of the MHPA. Both sites' vernal pools were identified by the adopted Recovery Plan for Vernal Pools of Southern California (USFWS, 1998) as necessary to stabilize populations of the following endangered and threatened species: *E. aristulatum*, *P. nudiuscula*, *N. fossalis*, *O. californica*, *B. sandiegonensis* and *S. woottoni*.

Both sites are subject to the same threats: development (both sites are privately owned and not conserved); invasive species (particularly grasses); trespass from foot traffic and off-road vehicles; litter, wind-blown debris, and illegal dumping; and fire and fire suppression activities. Both sites are recommended for conservation through public acquisition or private mitigation, and restoration or

enhancement of the vernal pools is appropriate given the high species diversity recorded historically at those sites. Restoration at J28 East should focus on creating stable populations of the aforementioned species, particularly on *E. aristulatum*, *M. minimus*, and *P. nudiuscula*, and restoration at J21 should focus particularly on *E. aristulatum*, *N. fossalis*, *O. californica*, and *P. nudiuscula*.

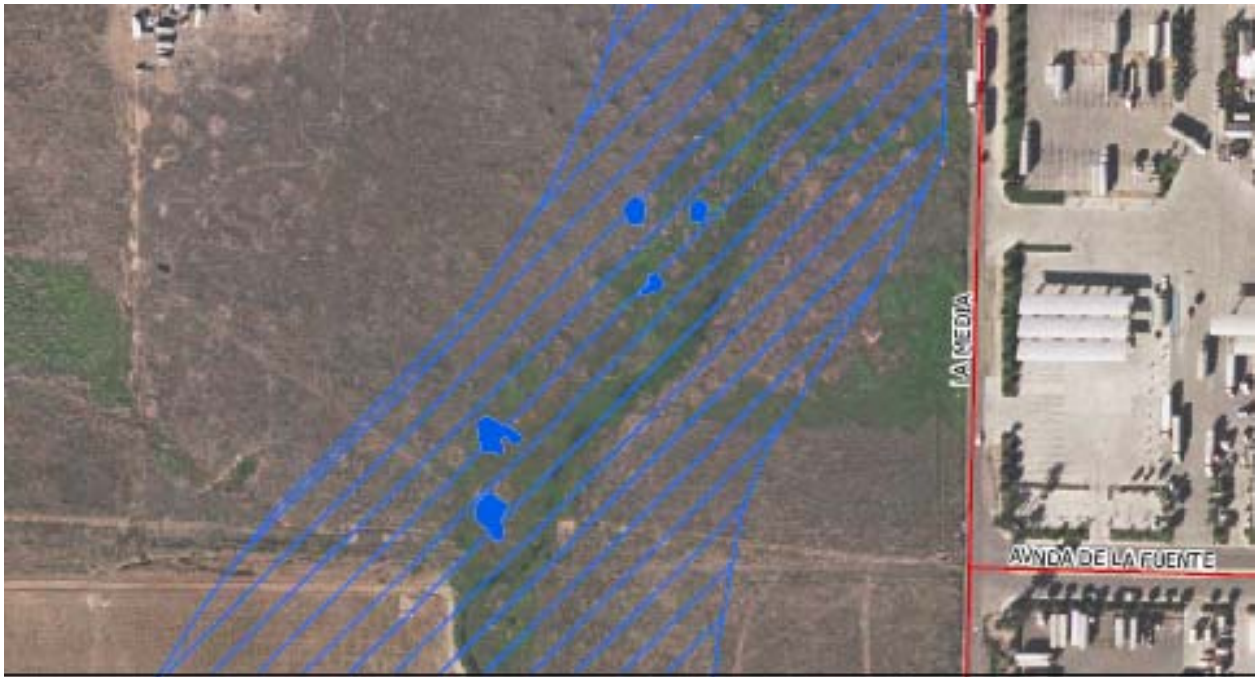

Figure 7. Location of vernal pools at the J28 East site (blue areas; blue hashed area depicts the MHPA).



Figure 8. Location of vernal pools at the J21 site (blue areas; blue hashed area depicts the MHPA).

Geologic Hazards

Unstable slopes, slide-prone geologic formations, faults and liquefaction-prone soils occur in many parts of the City. The relative risk of these geologic hazards has been mapped as part of the City of San Diego Seismic Safety Study (SSS) (City of San Diego Development Services, 2009). The maps indicate where potentially adverse geological conditions may exist, as defined by Geologic Hazard Category (<http://www.sandiego.gov/development-services/hazards/hazardsmaps.shtml>).

Evaluation of the SSS maps for the project area show the presence of Geologic Hazard Category 53, defined as level or sloping terrain with unfavorable geologic structure, which presents a low to moderate geologic risk.

The proposed project can be categorized as a minor public structure, which can be considered Building Type/Land Use Category IV, defined as “residential (single-family residences, apartments, etc.) and most commercial and *minor public structures*” (emphasis added). Group III, the next more stringent group, specifies places normally attracting large concentrations of people, and this project should not fall into that category.

Based on the presence of Geologic Hazard Category 53 and a Category IV project, a soil investigation and geologic investigation are anticipated. The City of San Diego (2008) *Guidelines for Geotechnical Reports* (<http://www.sandiego.gov/development-services/industry/pdf/geoguidelines.pdf>) describes these investigations in greater detail.

Grading

Not applicable; public works projects do not require a grading permit.

D. County Regulations and Permits

Because the areas in question are located within the City limits, county permits are not anticipated to be needed unless drainage or other infrastructure will connect to or otherwise affect county-owned infrastructure.

E. International Regulations and Permits

The International Boundary and Water Commission (IBWC) issues licenses and permits for activities in the IBWC right-of-way at the border or on IBWC maintained floodways. The *Criteria for Construction Activities within the Limits of USIBWAC Floodways* specifies that a license or permit is required for any proposed activities crossing or encroaching upon the floodplains of the IBWC flood control projects and right-of-way. This project does not affect the floodplains or right-of-way of any IBWC flood control project. Water quality considerations under IBWC jurisdiction focus on Texas rivers only and do not apply to the Otay Mesa area.

VI. Drainage Requirements, Considerations, and Opportunities

This report provides information primarily on the East and West Water Tanks drainage areas as these are the areas covered by the engineering reports. The West Watershed consists of smaller mesa-top watersheds that drain into the tributary canyons of Spring Canyon, which then flow into Mexico via the

Spring Canyon concentration point. While there is a need for some runoff management in these areas to reduce post-development peak flows to predevelopment levels, this area is of fairly low priority.

The engineering reports completed in the Otay Mesa area and summarized above focus primarily on the industrialized areas of the East Water Tanks drainage areas. This East Watershed is the largest watershed on the Mesa. All flows from the watershed collect at a concentration point at a large culvert where flows cross the U.S./Mexico border. The surrounding area is fairly flat and adjacent properties have difficulty draining effectively into the existing creek during larger storm events. The existing drainage is a combination of storm drains, improved channels, and detention basins, which discharge in many areas to natural drainage paths that do not have adequate hydraulic capacity. As projects have been developed in this area, portions of the private properties have been dedicated to the city as drainage easements or flood water storage easements (not verified as a part of this report).

Collectively, the engineering reports have recommended in one way or another that for this area to accommodate future development, the construction of a drainage channel along the east side of La Media crossing from the northeast corner to the northwest corner of the intersection of La Media with Siempre Viva Road would be required. The proposed channel would continue along the north side of Siempre Viva at La Media to the current culvert crossing along Siempre Viva to connect to the existing stream channel. This plan was selected because an existing drainage ditch located on the east side of La Media Road could be expanded to intercept flows from the east without creating potential conflicts from utilities in La Media Road; and flows from the west would continue to flow in the old drainage path. Additionally, this plan may reduce impacts to properties by following the property boundaries and could minimize potential utilities conflicts along Siempre Viva Road.

In this area, drainage alternatives should be given substantial thought by the City of San Diego. The next section presents several considerations that highlight key practical issues that might impinge on future drainage and development decisions.

A. Consideration 1: Drainage and Runoff Management Responsibilities

One of the first considerations is who has the responsibility to provide drainage the East Water tanks Drainage Area. The City of San Diego is responsible for public land including runoff from public roads and right of ways. However, as has been pointed out several times in this document, private property owners or developers are required to provide adequate storage and conveyance for 50-year flows in areas in the watershed that are above major (four lane) road crossings (City of San Diego Development Services, 2004). This is typical for most developments in the East Water Tanks drainage area. However, below major roadways, the drainage infrastructure must be designed to accommodate 100-year flows. The 100-year floodplain is also significant in that it is a standard used by the National Flood Insurance Program (NFIP) for floodplain management and to determine the need for flood insurance.

Figure 9 shows 100-year floodplain in the Water Tanks (East) drainage area (Kimley-Horn and Associate, 2007).

The interpretation of drainage language is that all public or private properties are required to provide adequate storage and conveyance for up to the 50-year flows, except for those in the natural drainage channel which are exempt. "Major roadways", that is, those that are four lane or greater and major roadway crossings would require designs that consider conveyance of the 100-year storm either beneath,

along and/or on the roadway as long as not more than one lane of the four is used for conveyance and the conveyance does not encroach onto private property outside of the road right-of-way. None of the areas shown in Figure 9 are considered to be below major roadways.

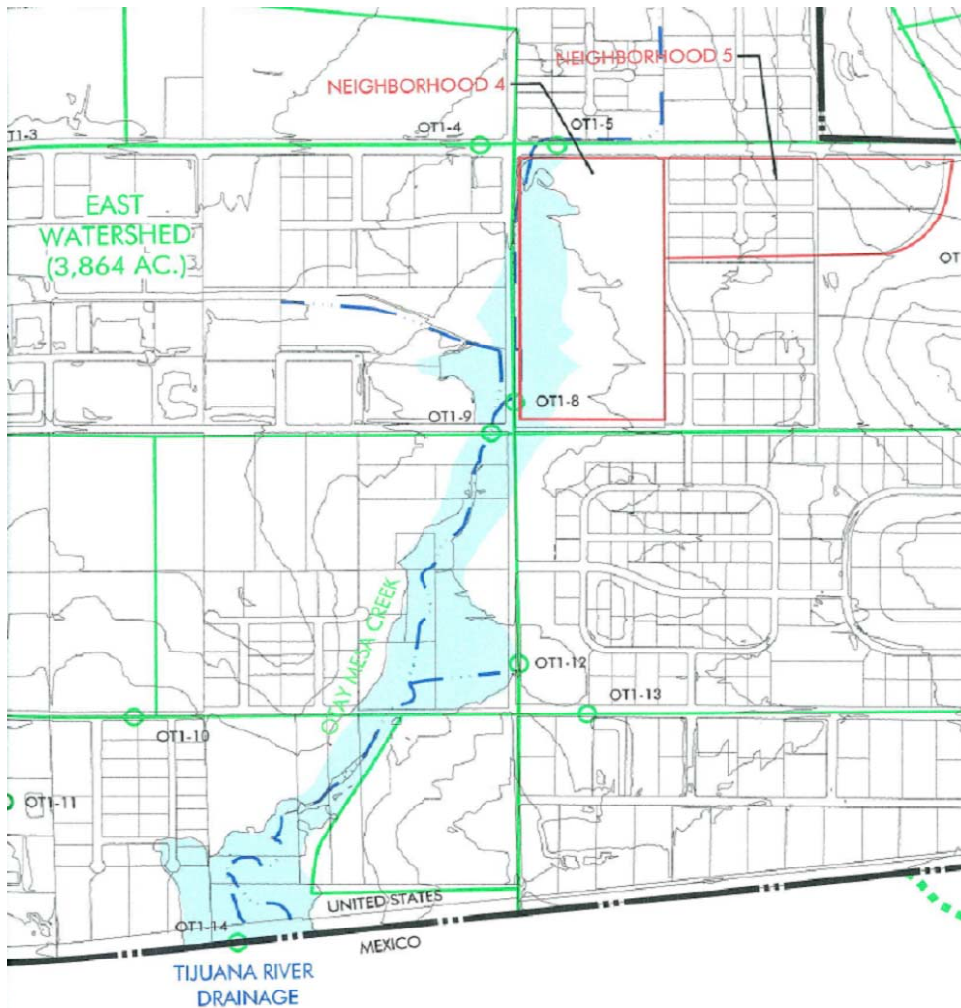

Figure 9. 100-year Floodplain in the Water Tanks (East) drainage area (Kimley-Horn and Associate, 2007).

B. Consideration 2: Potential for BMPs

The potential for stormwater BMPs is another consideration in the decision making process. If, in the future, conveyance along with water quality systems like BMPs are required in the Water Tanks East Drainage, current policies state that all BMPs be constructed for Priority Project Permanent Storm Water BMPs and High Priority Construction Storm Water BMPs. Most projects in the East Water Tanks watershed then would require the submission of a “Water Quality Technical Report” which follows the guidance “Storm Water Standards – A Manual for Construction & Permanent Storm Water Best Management Practices Requirements.”

Several factors must be considered when including BMPs in this area. The suitability and types of BMPs that may be selected are highly dependent on the existing conditions, including slope, soils, adequate area, and other natural resource considerations such as destruction of natural vernal pools. However,

this may potentially be an opportunity as well. As has previously been noted, this area is endemic to vernal pools. Projects within this area may provide a very good opportunity to include vernal pool restoration or creation and habitat improvements to support this unique ecosystem natural to Otay Mesa.

Potential Areas for Vernal Pools

Potential areas for restoring and/or improving vernal pools were identified using soil suitability, land use, and site availability. Bauder and McMillan (1998) describe suitable areas for vernal pools with slopes 9% or less and a substance layer with permeability of 0.06 inches/hour or less. Suitable areas using the criteria are shown in Figure 10.

The downstream areas of the Water Tanks (East) drainage area are mainly covered by two types of soils as shown in Figure 5. Major characteristics of the soils are summarized below (Bauder and McMillan 1998).

Huerhuero loam:

- Slopes: 2 to 9 percent
- Impervious sub-surface layer: 12 to 55 inches of clay and clay loam
- Permeability of sub-surface layer: <0.06 inches/hour
- pH: 5.3- for surface and 8.2 for sub-surface

Sckpen (Stockpen) gravelly clay loam:

- Slopes: 0 to 2 percent
- Impervious sub-surface layer: 21 to 60 inches of gravelly clay or clay
- Permeability of sub-surface layer: <0.06 inches/hour
- pH: 6.5 for surface and 8.0 for sub-surface

The characteristics of these soils make them ideal for creating vernal pools.

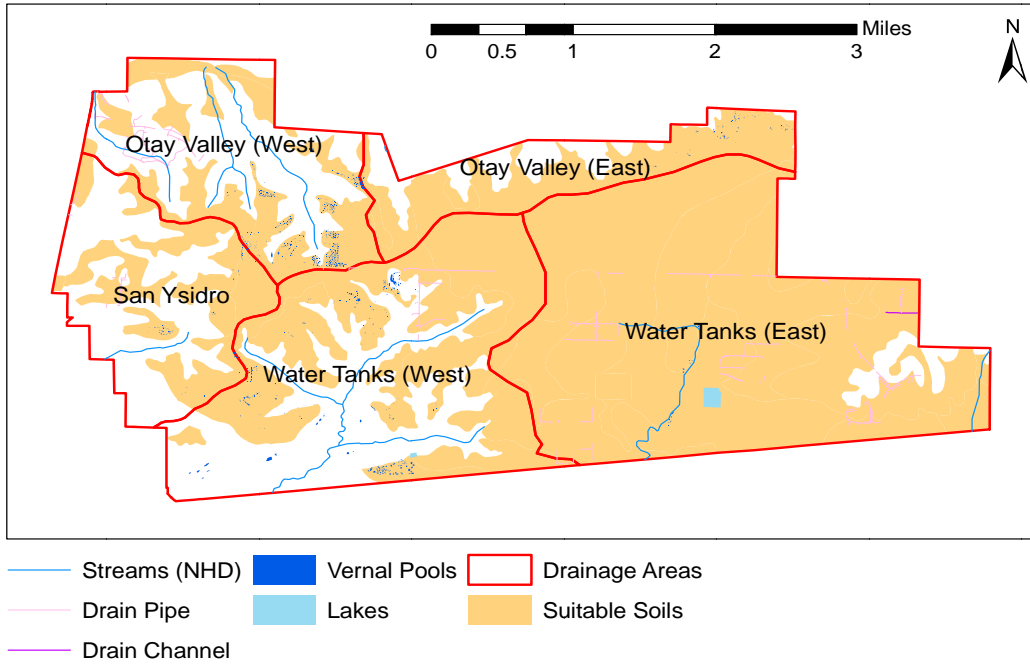

Figure 10. Suitable Areas for Vernal Pools with 9% or less Slope and 0.06 inches/hour or less Permeability

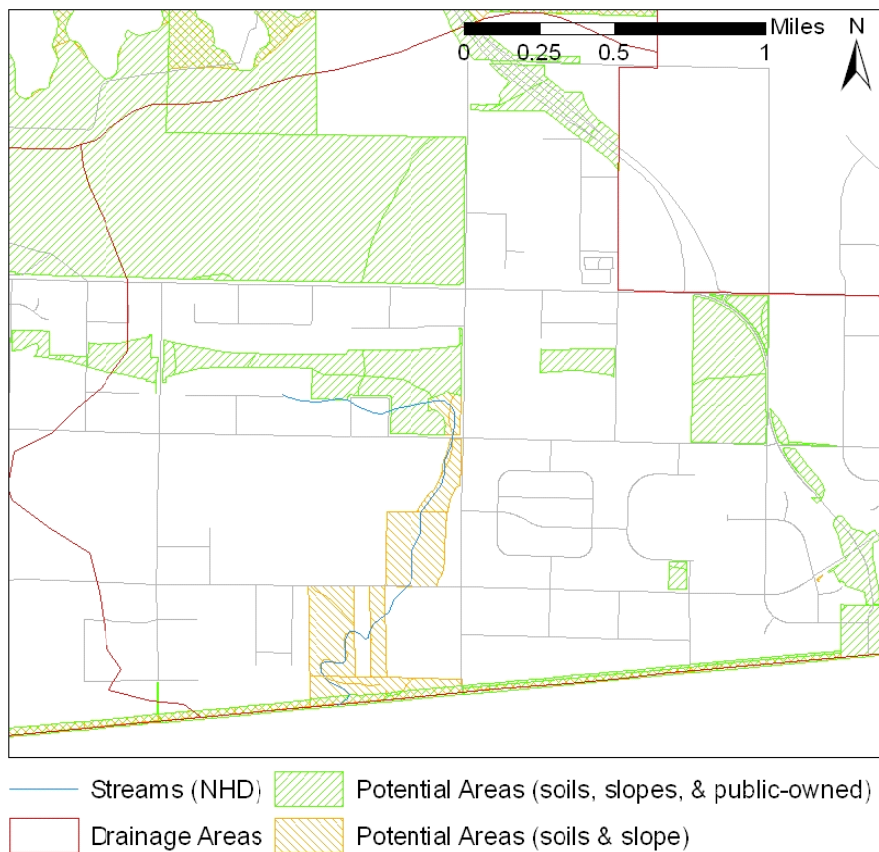

Figure 11. Potential Areas for Vernal Pools within the Water Tanks (East) drainage area

There are a number of parcels that could serve as potential areas for vernal pool creation as supplemental stormwater BMPs beyond the canal and detention system highlighted in the engineering reports.

C. Consideration 3: Estimated Annualized Costs for Planning, Permitting, Land Acquisition, Design, Construction, and Maintenance of Stormwater and Drainage Infrastructure

Another consideration is the cost of future maintenance of stormwater and drainage facilities if these were to be put in place.

Planning

Costs for planning include the effort required to further develop the project concept which, depending on the complexity of the project, could result in preparing a Project Concept Report. Additional administrative costs could be required to administer, manage and coordinate the project's implementation and are included with the planning costs. Administrative costs can vary widely with the complexity of the project, but for purposes of comparison, a value of 5 percent of the capital costs is assumed for planning.

Permitting

Regulatory requirements have to be met and environmental permits are required to implement most BMPs. The applicability of many regulations for a specific project depends on its site or design characteristics. Because the requirements imposed by regulatory agencies often have an effect on the project cost, the associated costs were included in the analysis for centralized BMPs: Because the opportunities identified for distributed structural BMPs are for areas of impervious cover and not applied to vacant or open spaces, the permitting effort anticipated for such projects is minimal, if any. Therefore, no separate costs are identified in the analysis for permitting. It is assumed that any permitting costs associated with the construction phase, such as erosion and sedimentation control, are included in the construction costs.

Land Acquisition

Cost estimates for any acquisition of private lands in Otay Mesa would be generated at the time when the City has determined to move forward with a public drainage facility. The cost estimates would be based on market value at that time, and would include BMP's as necessary.

Design

Designing structural BMPs requires collecting data, analyzing it, and preparing documents that can be used for constructing a project. Data collection could include geotechnical investigations, field investigation of existing utilities (potholing), and a topographic survey for mapping. The design deliverables are project plans and specifications that can be bid by a contractor for construction. Engineering costs can vary widely depending on the complexity of the project. For the purposes of the cost estimates, fixed rates of 5 and 10 percent were applied to the distributed and centralized BMP construction costs, respectively, to estimate the design/engineering cost. A lower percent was used for distributed BMP design costs because these BMPs are expected to have less time-intensive designs compared to centralized BMPs.

Construction

The typical levels of construction cost estimates are:

- Preliminary/Order of Magnitude—provide a range of costs at the planning level for a conceptually defined project
- Budget—cost estimates based on layouts and specific quantities
- Final/Definitive—prepared after the design documents are complete

The estimates for centralized BMPs on public and private property are not site-specific and are in the preliminary/order of magnitude category. To the extent possible, construction costs are based on approximate quantifications of the major components of the BMP.

Mobilization: Mobilization costs are highly variable depending on the magnitude of the project. A mobilization factor of 5% was included.

Excavation and removal: Excavation and removal costs include the cost of excavating the volume of soil required to provide the required storage, hauling the removed dirt offsite, and disposal to an appropriate facility.

Reinforced Concrete Pipe: Costs were derived from R.S. Means (2007) and are included to estimate the costs for constructing a storm drain extension of or to bypass an existing storm drain system.

Landscaping: One of the benefits of distributed BMPs is that they can be integrated into the site plan and often incorporated into the landscaping. Landscaping costs were estimated based on regional data.

Native Landscaping: Native landscaping should be used for any BMP because native landscaping is more adapted to the natural conditions which increase plant survivability.

Contingency: Because some of the project components have not been fully defined at this preliminary stage, a contingency factor of 25 percent should be applied to the construction costs to estimate the total construction costs and capture expected but as yet unidentified additional costs. The costs could arise from site-specific field conditions such as those associated with utility relocations, dewatering, and erosion and sedimentation control. At this stage of project development, the contingency also includes an allowance for such items as field facilities and construction scheduling, which might be required but are not specifically itemized. The contingency factor has **not** been applied to any of the cost functions or component cost estimates itemized in Table 7.

Table 7: Per Unit Cost Estimates for Construction Components

Construction Component	Cost
Mobilization	5% of construction total
Excavation and Removal	\$25.00/yd ³
Asphalt/Base Removal	\$8.00/yd ³
Site Preparation	\$20.00/ft ²
Reinforced Concrete Pipe	\$8.00 per diameter (inch) per length (ft)
Landscaping (includes mulch/sod and vegetation)	\$5.00/ft ²
Native Landscaping	\$25.00/ft ²
Planning	5% of total

Construction Component	Cost
	construction costs
Permits/Studies	Included in design
Design (Centralized)	10% of total construction costs
Design (Distributed)	5% of total construction costs
Contingency for Planning Estimate (Centralized)	25% of total construction costs
Contingency for Planning Estimate (Distributed)	15% of total construction costs

This costing information can be used by the City of San Diego to evaluate costs of planning, permitting, operating and maintaining the proposed drainage facilities and BMPs.

D. Consideration 4: Risk-Based Analyses

One method of assessing the level of service to provide to some drainage areas is to evaluate the risk to private citizens and the economic losses due to flooding. Risk costs are those cost items incurred due to the unexpected failure in the drainage system due to flooding and can broadly be categorized as tangible and intangible costs. Tangible costs are those measured as direct monetary losses including damage to properties and structures, loss of business, cost of repair, etc. Intangible costs include psychological trauma, damage to the environment, and other costs that do not have a direct, agreed upon, or known value.

Economic risks and flood loss costs were considered began to take hold in the early 1960's. One of the early applications was risk based concept to hydraulic design of highway culverts. Pritchett used four actual locations, calculating the investment costs with the expected flood damage costs on an annual basis for several design alternatives. The results indicated that a more economical solution would be reached by selecting smaller culvert sizes compared to the traditional return method typically used.

The basic concept of risk based design is shown schematically in Figure 13. The risk function can account for the potential undesirable consequence associated with the failure of hydraulic structures on the damage and costs related to flooding costs. However, it must be recognized that the risk costs associated with the failure of hydraulic structures cannot be precisely predicted from year to year

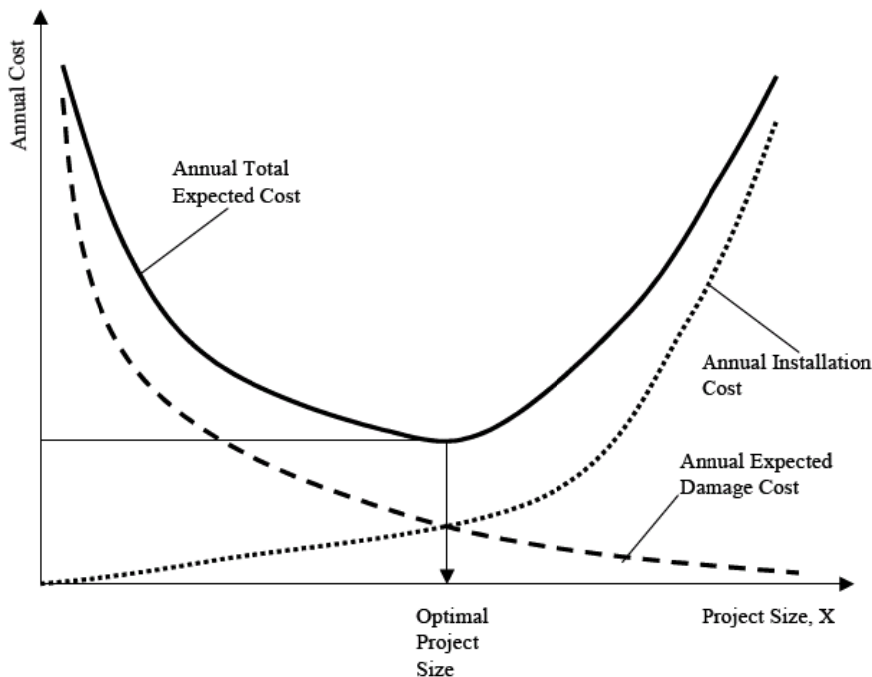

Figure 12. Risk-Based Design Costs Analyses Concepts

The Annual Total Expected Cost is the sum of the annual expected installation and maintenance costs and the annual expected damage and flooding costs. The sum of cost that makes up the intersection between the individual cost curves is the estimated optimal project size. Using this risk-based approach projects can more efficiently determine the estimated costs to inform project design.

For Otay Mesa, the engineering reports summarized potential drainage designs but do not consider the design based on a risk-based approach. These reports use the 100-year return interval for their recommended designs. It should be noted that the land uses where the drainage upgrades are suggested are primarily industrial in nature. This may impact tangible economic costs (e.g., transportation/delivery, vehicle and employee access, etc.), but other intangible costs such as loss of life and threat to personal safety are likely to be minimal because of very little if any residential land uses in this area.

A risk-based approach may be well suited for decision making in the Otay Mesa area. To adequately determine the size of a project to be designed, the annual total expected costs should be evaluated to assist in determining the optimal project size most appropriate for the drainage area. While risk based analyses is not as commonly used by engineers and planners, it is recommended that this task include economists from the City to consider risk-based costs when evaluating engineering designs such as those planned for the Otay Mesa drainage areas.

E. Consideration 5: Border Issues

There are some transboundary considerations beyond what was covered in the regulatory section of this report. The International Boundary and Water Commission (IBWC) is the lead agency for transboundary water management and settlement of bilateral disputes relating to managing shared water resources. An

international pollution abatement board makes recommendations to the EPA administrator for the abatement of international water pollution.

In August 1983, the U.S.-Mexico Border Environment Cooperation Agreement, better known as the La Paz Agreement, initiated a new era of formal multinational consultation and heightened attention to environmental issues within the border region. The La Paz process was strengthened by the 1992-1994 Integrated Border Environmental Program, the 1995-2000 Border XXI Program, and most recently by EPA's Border 2012 Program. These programs broadened the scope of border water management to include pollution prevention, water quality management, a concern for ecological processes, and a concern for advancing sustainable development of water resources along the border. Although these programs acknowledge IBWC's historic treaty role in binational water planning, they favor more regionalized and local workgroups and task forces to de-centralize decision making and to mobilize local resources for local solutions to water issues.

Even with these layers of bureaucracy, it is understood that Governments may be liable when mismanagement of reservoirs or other storage systems result in major flooding of downstream areas. For example, The U.S. Court of Claims [Gasser v United States, 14 Cl. Ct 476 (1988)] has held that the U.S. may be liable for flood damages in Mexico caused by operation of an upstream government reservoir. However, catastrophic natural events do not seem to apply to flood control requirements. Similarly, there is no standard set for the control of flows from the U.S. into Mexico, especially for intermittent or ephemeral streams such as the drainage of the Water Tanks (East) catchment. If a canal and detention system were built in this area, consideration of this area as a "hydrocommons", hydraulically linked basins connected through man-made engineered systems, may be necessary (Michel, 2000). The changing of current drainage patterns and timing of flow across the border in the Water Tanks (East) watershed of Otay Mesa could significantly alter downstream (Mexico) hydrologic functions such as water quality, aquatic habitat, riparian ecosystems, and land use. These issues are weakly addresses with federal, state, and international laws with the implications of constructing the proposed drainage and flood control systems unclear. Further investigation into the legal responsibilities and ramifications should be further reviewed if the drainage and detention projects proceed.

VII. Conclusions

This report has provided a review of previously developed engineering drainage reports with the report recommendations summarized. An inventory of current land use and drainage patterns, as well as regulations regarding storm water were provided as background to support up-to-date considerations for the placement of stormwater management facilities including the possibility of vernal pool restoration. This type of restoration may be required to mitigate impacts to sensitive areas (e.g., vernal pools) associated with the implementation of the previously recommended drainage reports. The five considerations that were forwarded in this report are:

- Drainage and Runoff Management Responsibilities
- Potential for BMPs
- Estimated Annualized Costs for Planning, Permitting, Land Acquisition, Design, Construction, and Maintenance of Stormwater and Drainage Infrastructure
- Risk-Based Analyses
- Border issues

Through the consideration of these issues, the many regulatory layers, background on environmental sensitive areas of Otay Mesa, data compilation and description, and the summary and evaluation of the engineering reports the City of San Diego will have the necessary information for decision analysis for the Otay Mesa drainage area.

VIII. References

- Bauder, E. T., and S. McMillan. 1998. *Current distribution and historical extent of vernal pools in Southern California and Northern Baja California, Mexico*. In E. W. Witham, E. Bauder, D. Belk, W. Ferren, and R. Ornduff (eds.). *Ecology, Conservation and Management of Vernal Pool Ecosystems: Proceedings from a 1996 Conference*. California Native Plant Society, Sacramento, California.
- California Department of Fish and Game. 2008. California Code of Regulations, Section 783.2. Incidental Take Permit Applications. http://www.dfg.ca.gov/habcon/cesa/incidental/CodeRegT14_783.pdf. Last updated April 25, 2008. Accessed November 30, 2009.
- California Department of Fish and Game. 2009. California Endangered Species Act (CESA). <http://www.dfg.ca.gov/habcon/cesa/>. Accessed November 30, 2009.
- City of San Diego. *Notice to All Private Engineers, August 7, 1987*.
- City of San Diego. 1994. *City of San Diego significance determination guidelines under the California Environmental Quality Act*. January 1994, revision.
- City of San Diego. 1997. MSCP Subarea Plan. <http://www.sandiego.gov/planning/mscp/pdf/subarea.pdf>. Last updated March 1997. Accessed November 30, 2009.
- City of San Diego. 2008. *Guidelines for Geotechnical Reports*. <http://www.sandiego.gov/development-services/industry/pdf/geoguidelines.pdf>. Accessed November 30, 2009.
- City of San Diego Development Services. *Land Development Manual, Appendix B, Drainage Design Manual*. 2004. www.sandiego.gov/developmentservices/industry/landdevmanual.shtml. Accessed December 04, 2009.
- City of San Diego Development Services. 2009. *Development Permit and Grading Geotechnical Study Requirements*. <http://www.sandiego.gov/development-services/industry/pdf/infobulletin/ib515.pdf>. Last updated March 2009. Accessed November 30, 2009.
- City of San Diego Planning Department. *City of San Diego Vernal Pool Inventory 2002 – 2003*. 2004. . <http://www.sandiego.gov/planning/mscp/vpi/index.shtml>. Accessed November 16, 2009.
- Draft City of San Diego Multiple Species Conservation Program Vernal Pool Management Plan*. 2004. <http://www.sandiego.gov/planning/mscp/vpmp/index.shtml>. Accessed November 16, 2009.
- Gasser v United States, 14 Cl. Ct 476 (1988)
- Kimley-Horn and Associates, Inc., *Otay Mesa Drainage Study*. August 9, 1999. Prepared for The City of San Diego.

Kimley-Horn and Associates, Inc., *Drainage Study for Otay Mesa Community Plan Update*. May 2005. Prepared for MNA Consulting.

Kimley-Horn and Associates, Inc., *Drainage Study for the Otay Mesa Community Plan Update*. April 2007. Prepared for MNA Consulting.

Leedshill – Herkenhoff, Inc., *Otay Mesa Drainage Master Plan – Preliminary Channel Design*. January 1988. Prepared for The City of San Diego.

Leidy, Robert A., and Elizabeth White. 1998. *Toward an ecosystem approach to vernal pool compensation and conservation*. Ecology, Conservation, and Management of Vernal Pool Ecosystems – Proceedings from a 1996 Conference. California Native Plant Society, Sacramento CA. pp 263-273. <http://www.vernalpools.org/proceedings/leidy.pdf>. Accessed November 16, 2009.

Michel, S.M. 2000. Defining Hydrocommons Governance along the Border of the Californias: A Case Study of Transbasin Diversions and Water Quality in the Tijuana-San Diego Metropolitan Region. *Natural Resources Journal*, Vol. 40 pp. 931-970.

U.S. Fish and Wildlife Service. 2005. *Recovery Plan for Vernal Pool Ecosystems of California and Southern Oregon*. Portland, Oregon. xxvi + 606 pages. <http://www.fws.gov/endangered/recovery/index.html#plans>. Accessed November 16, 2009.

U.S. Fish and Wildlife Service. 2005. Habitat Conservation Plans Section 10 of the Endangered Species Act. http://www.fws.gov/endangered/pdfs/HCP/HCP_Incidental_Take.pdf. Accessed November 30, 2009.

APPENDIX G-3

Water Quality Technical Report



Water Quality Technical Report

Otay Mesa
Community Plan Update

January, 2007

Prepared for:

MNA Consulting
427 C Street, Suite 308
San Diego, CA 92101

Prepared by:

Kimley-Horn and Associates, Inc.
517 Fourth Ave., Suite 301
San Diego, CA 92101

©Kimley-Horn and Associates, Inc. 2007



WATER QUALITY TECHNICAL REPORT

Otay Mesa Community Plan

January, 2007

Prepared for:
MNA Consulting
427 C Street, Suite 308
San Diego, CA 92101



TABLE OF CONTENTS

Introduction	1
Pollutants That May Effect Storm Water Quality	1
Proposed Control Measures	2
Operation and Maintenance Procedures	5
Operation and Maintenance Responsibility	5
Installation Costs	6
Conclusion.....	7

APPENDICES

Appendix A	Otay Mesa Community Plan Watershed and BMP Exhibit
Appendix B	Treatment BMP Specifications
Appendix C	Otay Mesa Drainage Study (without attachments)
Appendix D	References



1. Introduction

The Otay Mesa Community is quickly developing in the City of San Diego. This area consists of approximately 7,000 acres bounded by the City of Chula Vista and the Otay River Valley on the north, the International Border on the south, Interstate 805 on the west, and the County of San Diego on the east. The far northwest arm of the Mesa is fully developed and all other areas are envisioned for residential, industrial, and commercial development in the Otay Mesa Community Plan.

The Mesa consists of flat terrain and shallow swales for drainage paths. Most of the Mesa slopes north to south resulting in runoff entering Mexico at several points. Increased development has caused concentrated flows in culverts under roads, redefined some of the historical drainage paths, and increased runoff into Mexico. For the most part, the existing drainage facilities have been constructed by private development causing non-continuous facilities and difficulty for subsequent developers to tie into the existing facilities. The Otay Mesa Creek is the only significant creek on the Mesa which lies in the East Watershed (see **Appendix A** for watersheds). The Drainage Study prepared for the Otay Mesa Community Plan Update proposes improvements to the Otay Mesa Creek with the La Media Channel and Border Detention Basin in the East Watershed to be constructed to convey flow and prevent downstream flooding. From the hydraulic analysis in the Drainage Study, Otay Mesa Creek crosses the border into Mexico just north of the Tijuana Airport and eventually to the Tijuana River. The West Perimeter Watershed and West Watershed also flow into the Tijuana River. The Tijuana River Watershed is a water quality impacted watershed; therefore, the water quality must be addressed for additional development. The Tijuana River is included in the 2002 Clean Water Act Section 303(d) List of Water Quality Limited Segments approved by the U.S. Environmental Protection Agency (EPA) and by the State Water Resources Control Board (SWRCB) on February 4, 2003.

The proposed detention basins in the West Perimeter Watershed and West Watershed will be constructed as part of development in the immediate vicinity of future projects. These detention basins are recommended to also function as treatment BMPs for runoff caused by new development. The La Media Channel and Border Detention Basin will be constructed before new development along the creek takes place (see **Appendix A** for locations). These BMPs target sediment, nutrients, trash, metals, oil & grease, and organics from existing and future development prior to crossing the border and into the Tijuana River.

This document complies with the City of San Diego's Standard Urban Storm Water Mitigation Plan and Storm Water Standards Manual.

2. Pollutants that May Affect Storm Water Quality

Future use of the undeveloped land may consist of residential, industrial, and commercial projects. From Table 2 of the City of San Diego's Storm Water Standards Manual, the anticipated and potential pollutants can be identified based on project category. For a residential development, the anticipated pollutants of concern are sediments, nutrients, trash and debris, and pesticides. The potential pollutants of concern include oxygen demanding substances, oil & grease, and bacteria & viruses. The anticipated pollutants for commercial developments include trash & debris and oil & grease. Potential pollutants are sediments, nutrients, organic compounds, oxygen demanding substances, bacteria &



viruses, and pesticides.

The Tijuana River is listed on the 303(d) list for impaired water bodies for bacteria, nutrients, oxygen demanding substances, low dissolved oxygen, pesticides, synthetic organics, and trash. This project proposes the La Media Channel and Border Detention Basin to improve existing drainage. Since residential, industrial, and commercial developments are planned uses of the site, this water quality technical report will not address additional pollutants (associated with the planned uses). Permanent storm water BMPs must be incorporated into future project where necessary to mitigate the impacts of urban runoff as a result of the development. For this project, the proposed channel and detention basin will contribute to filtering of pollutants prior to crossing the border. Heavy riparian vegetation will be allowed to grow in the channel, which traps pollutants. The channel slowly conveys runoff into a detention basin where runoff will be held for some minimum time allowing pollutants to settle prior to discharge.

3. Proposed Control Measures

The Water Quality Technical Report or the Storm Water Management Plan for future projects in the Otay Mesa Community rely on implementation of site design BMPs, source control BMPs, and treatment control BMPs. This project, Otay Mesa Community Plan Update, will only implement treatment control BMPs for the region. Future developers must address site design BMPs, source control BMPs, and additional treatment control BMPs based on anticipated and potential pollutants for the corresponding planned use. The main objective is to ensure that pollutants do not come in contact with storm water by reducing or eliminating the pollutants. These objectives are achieved by implementing the required source, site, priority project and treatment BMPs set forth in the City of San Diego Storm Water Standards.

Site Design

The following Site design BMPs are identified for future development (City Storm Water Standards – Section III.2.A and Appendix C):

1. Minimize impervious footprint. (1) Increase building density (number of stories above or below ground); (2) construct walkways, trails, patios, overflow parking lots and alleys and other low-traffic area with permeable surfaces, such as pervious concrete, porous asphalt, unit pavers, and granular materials; (3) construct streets, sidewalks and parking lot aisles to the minimum widths necessary, provided that public safety and a walkable environment for pedestrians are not compromised; and (4) minimize the use of impervious surfaces, such as decorative concrete, in the landscape design.
2. Conserve natural areas and provide buffer zones between natural water bodies and the project footprint. (1) Concentrate or cluster development on the least environmentally sensitive portions of a site while leaving the remaining land in a natural, undisturbed condition; and (2) use natural drainage systems to the maximum extent practicable (natural drainages and vegetated swales are preferred over using lined channels or underground storm drains).
3. Minimize directly connect impervious areas. (1) Where landscaping is proposed, drain rooftops into adjacent landscaping prior to discharging to the storm water conveyance system; and (2) where landscaping is proposed, drain impervious parking lots, sidewalks, walkways, trails, and patios into adjacent landscaping.



4. Maximize canopy interception and water conservation. (1) Preserve existing native trees and shrubs; and (2) plant additional native or drought tolerant trees and large shrubs in place of non-drought tolerant exotics.
5. Convey runoff safely from the tops of slopes.
6. Vegetate slopes with native or drought tolerant vegetation
7. Stabilize permanent channel crossings.
8. Install energy dissipaters, such as riprap, at the outlets of new storm drains, culverts, conduits, or channels that enter unlined channels in accordance with applicable specifications to minimize erosion. Energy dissipaters shall be installed in such a way as to minimize impacts to receiving waters.

Source Control

The following source control BMPs are identified for future development (City Storm Water Standards – Section III.2.B and Appendix C):

1. Outdoor material storage areas will be designed to reduce pollution introduction. Any hazardous materials with the potential to contaminate urban runoff shall be: (1) placed in an enclosure such as, but not limited to, a cabinet, shed, or similar structure that prevents contact with rain, runoff or spillage to the storm water conveyance system; and (2) protected by secondary containment structures such as berms, dikes or curbs. The storage area shall be paved and sufficiently impervious to contain leaks and spills and have a roof or awning to minimize direct precipitation within the secondary containment area.
2. Trash storage areas shall be: (1) paved with an impervious surface, designed not to allow runoff from adjoining areas, and screened or walled to prevent off-site transport of trash; and, (2) contain attached lids on all trash containers that exclude rain; or (3) contain a roof or awning to minimize direct precipitation.
3. Integrated pest management principles shall be employed including planting pest-resistant or well-adapted varieties such as native plants and using pesticides as a last line of defense. These principles shall be extended through the distribution of IPM educational materials to future site tenants.
4. Efficient irrigation systems and landscape design should employ rain shutoff devices to prevent irrigation during and after precipitation, irrigation design according to specific water requirements, and flow reducers or shutoff valves triggered by a pressure drop to control water loss in the event of broken sprinkler heads or lines.
5. All inlets should contain prohibitive illegal dumping language.

Priority Project

The following Priority Project design BMPs are identified for applicable future developments (City Storm Water Standards – Section III.2.C):

1. The design of private roadways shall use at least one of the following: (1) rural swale system; (2) urban curb/swale system; or (3) dual drainage system.
2. Residential driveways shall have one of the following: (1) shared access; (2) flared entrance; (3) wheelstrips (paving under tires); (4) porous paving; or (5) designed to drain into landscaping prior to discharging to the storm water conveyance system. Uncovered temporary



- or guest parking on private residential lots shall be: (1) paved with permeable surface; or (2) designed to drain into landscaping prior to discharging to the storm water conveyance system.
3. Loading/unloading dock areas shall include the following: (1) cover loading dock areas, or design drainage to preclude urban run-on and runoff; and (2) an acceptable method of containment and pollutant removal, such as a shut-ff valve and containment area.
 4. Maintenance bays shall include at least one of the following: (1) repair/maintenance bays shall be indoors; or, (2) designed to preclude urban run-on and runoff. Maintenance bays shall include a repair/maintenance bay drainage system to capture all wash water, leaks, and spills.
 5. Outdoor areas for vehicle & equipment washing shall be: (1) self-contained to preclude run-on and run-off, covered with a roof or overhang, and equipped with a clarifier or other pre-treatment facility; and (2) properly connected to a sanitary sewer.
 6. Outdoor processing areas shall: (1) cover or enclose areas that would be the most significant source of pollutants; or, (2) slope the area toward a dead-end sump; or, (3) discharge to the sanitary sewer system. Grade or berm processing area to prevent run-on from surrounding areas.
 7. Where landscaping is proposed in surface parking areas, incorporate landscape areas into the drainage system. Overflow parking may be constructed with permeable paving.
 8. Non-Retail fueling areas should be designed with the following: (1) paved with Portland cement concrete or equivalent; (2) designed to extend 6.5 feet from the corner of each fuel dispenser, or the length at which the hose and nozzle assembly may be operated plus 1 foot, whichever is less; (3) sloped to prevent ponding; (4) separated from the rest of the site by a grade break; and (5) designed to drain to the project's treatment control BMP. Must have overhanging roof structure or canopy that is equal to or greater than the area within the fuel dispensing area's grade break and designed not to drain onto or across the fuel dispensing area.
 9. Steep hillside areas shall be landscaped with deep-rooted, drought tolerant plant species.

Treatment Control

Treatment control BMPs are designed to filter or treat runoff prior to discharging into an on-site or off-site storm drain system. The largest watershed of the Mesa is the East Watershed encompassing approximately 4,000 acres. This watershed flows into Mexico at a single point between Britannia and La Media roads. The La Media Channel and Border Detention Basin will function as a treatment design BMP (See Exhibit A for locations). Runoff drains to the La Media Channel where runoff is slowly conveyed through heavy riparian vegetation. The channel slopes at 0.25% for approximately 3,500 feet and behaves similar to a vegetated swale. Runoff is then discharged into the Border Detention Basin where storm water flow is slowed in order for pollutants to settle. The basin is approximately 58 acres with a maximum water depth of 6ft. These BMPs were chosen on the basis of site design feasibility and the City Storm Water Standards- Section III.2.D. Additional site treatment control BMPs may be necessary and addressed for future developments.



4. Operation and Maintenance Procedures

Grass Lined Channel

- 1) Inspect swales at least twice annually for erosion, damage to vegetation, and sediment and debris. See BMP detail TC-30 in **Appendix B** for preferred schedule.
- 2) Regularly inspect swales for pools of standing water to prevent mosquito breeding.
- 3) Every few years maintenance of dead or fallen trees may be required.

Detention Basin

An effective maintenance program should include the following key components:

1. Weather-triggered inspections – Inspect after several storm events for bank stability and to determine if the desired residence time has been achieved.
2. Regular inspections – Inspect semi-annually and after significant storm events. Inspect for the issues as described in BMP detail TC-22 in **Appendix B**.
3. Sediment Removal – Remove accumulated sediment when accumulated sediment volume exceeds 10-20% of the basin volume or when accumulation reaches 6 inches or if re-suspension is observed. Significant sediment deposition is not expected after development on The Mesa is completed.
4. Water Removal – Basin will be designed with a “low-flow” outlet; however, if water remains remove standing water by cleaning drainage path within 72 hours after accumulation.
5. General Maintenance Activities – see BMP detail TC-22 in **Appendix B** for maintenance activities and suggested frequency.

5. Operation and Maintenance Responsibility

A Maintenance District will be created for maintaining the channel and regional detention basin. Project detention/water quality basins and BMPs will be maintained by the project owners.



6. Installation Costs

La Media Channel and Border Detention Basin

Preliminary Opinion of Probable Construction Cost

2/8/2005

Kimley-Horn and Associates

Construction Items

Item No.	Description	Quantity	Units	Unit Price	Cost
1	Excavation	822,500	CY	\$2	\$1,645,000
2	Airway Road culvert (6~5'wx5'h)	300	CY	\$1,500	\$450,000
3	La Media/Airway Road culvert (6~10'wx6'h)	1,500	CY	\$1,500	\$2,250,000
4	Siempre Viva Road culvert (8~10'wx8'h)	1,490	CY	\$1,500	\$2,235,000
5	Detention Basin Outlet Structure	1	LS	\$100,000	\$100,000
6	Traffic Control	1	LS	\$100,000	\$100,000
7	Utility Relocation	1	LS	\$150,000	\$150,000
8	Street Repair	1	LS	\$50,000	\$50,000
9	Erosion Control	1	LS	\$50,000	\$50,000
10	Revegetation	1	LS	\$600,000	\$600,000
		Subtotal			\$7,630,000
		Contingency	20%		\$1,526,000
		Total			\$9,156,000

Land Acquisition

1	Land Acquisition (outside MHPA)*	2,610,000	SF	\$4	\$10,440,000
2	Land Acquisition (inside MHPA)**	1,820,000	SF	\$1	\$1,820,000
		Subtotal			\$12,260,000
		Contingency	20%		\$2,452,000
		Total			\$14,712,000

Total Cost (Construction and Land Acquisition)

\$23,868,000

- Notes:
- * Includes area of detention basin and channel south of Siempre Viva
 - ** Includes entire area within MHPA boundary
 - *** Estimate does not include engineering, environmental, geotechnical, surveying, etc.



8. Conclusion

The future developments on the Mesa will include source, site, priority project, and treatment control BMPs consistent with the City of San Diego Storm Water Standards. This project consists of treatment control which will be in place before adjacent development is completed. The treatment control consist of a detention basin and a grass lined channel for the watershed to minimize downstream flooding and to treat and filter runoff prior to discharge across border. Use of these control measures complies with the Municipal Storm Water National Pollutant Discharge Elimination System (NPDES) Permit and the City of San Diego's Storm Water Standards.

K:\095407000\Word\WQTR-Otay Mesa.doc

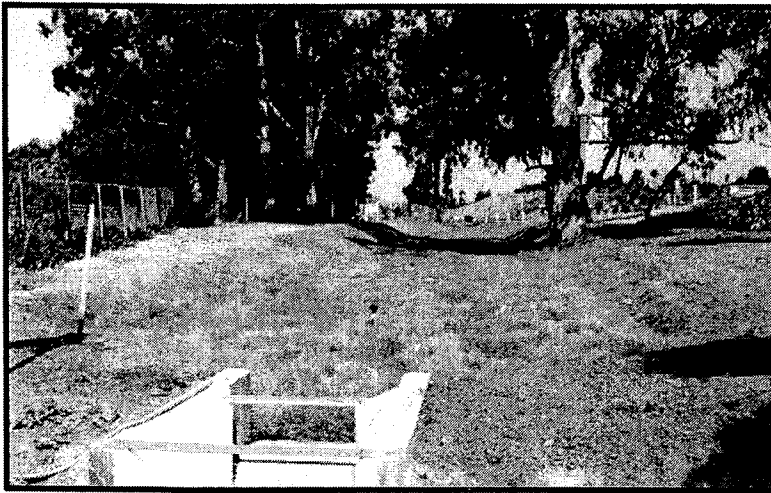

Description

Vegetated swales are open, shallow channels with vegetation covering the side slopes and bottom that collect and slowly convey runoff flow to downstream discharge points. They are designed to treat runoff through filtering by the vegetation in the channel, filtering through a subsoil matrix, and/or infiltration into the underlying soils. Swales can be natural or manmade. They trap particulate pollutants (suspended solids and trace metals), promote infiltration, and reduce the flow velocity of stormwater runoff. Vegetated swales can serve as part of a stormwater drainage system and can replace curbs, gutters and storm sewer systems.

California Experience

Caltrans constructed and monitored six vegetated swales in southern California. These swales were generally effective in reducing the volume and mass of pollutants in runoff. Even in the areas where the annual rainfall was only about 10 inches/yr, the vegetation did not require additional irrigation. One factor that strongly affected performance was the presence of large numbers of gophers at most of the sites. The gophers created earthen mounds, destroyed vegetation, and generally reduced the effectiveness of the controls for TSS reduction.

Advantages

- If properly designed, vegetated, and operated, swales can serve as an aesthetic, potentially inexpensive urban development or roadway drainage conveyance measure with significant collateral water quality benefits.

Design Considerations

- Tributary Area
- Area Required
- Slope
- Water Availability

Targeted Constituents

<input checked="" type="checkbox"/>	Sediment	▲
<input checked="" type="checkbox"/>	Nutrients	●
<input checked="" type="checkbox"/>	Trash	●
<input checked="" type="checkbox"/>	Metals	▲
<input checked="" type="checkbox"/>	Bacteria	●
<input checked="" type="checkbox"/>	Oil and Grease	▲
<input checked="" type="checkbox"/>	Organics	▲

Legend (Removal Effectiveness)

- Low
- High
- ▲ Medium



- Roadside ditches should be regarded as significant potential swale/buffer strip sites and should be utilized for this purpose whenever possible.

Limitations

- Can be difficult to avoid channelization.
- May not be appropriate for industrial sites or locations where spills may occur
- Grassed swales cannot treat a very large drainage area. Large areas may be divided and treated using multiple swales.
- A thick vegetative cover is needed for these practices to function properly.
- They are impractical in areas with steep topography.
- They are not effective and may even erode when flow velocities are high, if the grass cover is not properly maintained.
- In some places, their use is restricted by law: many local municipalities require curb and gutter systems in residential areas.
- Swales are more susceptible to failure if not properly maintained than other treatment BMPs.

Design and Sizing Guidelines

- Flow rate based design determined by local requirements or sized so that 85% of the annual runoff volume is discharged at less than the design rainfall intensity.
- Swale should be designed so that the water level does not exceed 2/3rds the height of the grass or 4 inches, whichever is less, at the design treatment rate.
- Longitudinal slopes should not exceed 2.5%
- Trapezoidal channels are normally recommended but other configurations, such as parabolic, can also provide substantial water quality improvement and may be easier to mow than designs with sharp breaks in slope.
- Swales constructed in cut are preferred, or in fill areas that are far enough from an adjacent slope to minimize the potential for gopher damage. Do not use side slopes constructed of fill, which are prone to structural damage by gophers and other burrowing animals.
- A diverse selection of low growing, plants that thrive under the specific site, climatic, and watering conditions should be specified. Vegetation whose growing season corresponds to the wet season are preferred. Drought tolerant vegetation should be considered especially for swales that are not part of a regularly irrigated landscaped area.
- The width of the swale should be determined using Manning's Equation using a value of 0.25 for Manning's n.

Construction/Inspection Considerations

- Include directions in the specifications for use of appropriate fertilizer and soil amendments based on soil properties determined through testing and compared to the needs of the vegetation requirements.
- Install swales at the time of the year when there is a reasonable chance of successful establishment without irrigation; however, it is recognized that rainfall in a given year may not be sufficient and temporary irrigation may be used.
- If sod tiles must be used, they should be placed so that there are no gaps between the tiles; stagger the ends of the tiles to prevent the formation of channels along the swale or strip.
- Use a roller on the sod to ensure that no air pockets form between the sod and the soil.
- Where seeds are used, erosion controls will be necessary to protect seeds for at least 75 days after the first rainfall of the season.

Performance

The literature suggests that vegetated swales represent a practical and potentially effective technique for controlling urban runoff quality. While limited quantitative performance data exists for vegetated swales, it is known that check dams, slight slopes, permeable soils, dense grass cover, increased contact time, and small storm events all contribute to successful pollutant removal by the swale system. Factors decreasing the effectiveness of swales include compacted soils, short runoff contact time, large storm events, frozen ground, short grass heights, steep slopes, and high runoff velocities and discharge rates.

Conventional vegetated swale designs have achieved mixed results in removing particulate pollutants. A study performed by the Nationwide Urban Runoff Program (NURP) monitored three grass swales in the Washington, D.C., area and found no significant improvement in urban runoff quality for the pollutants analyzed. However, the weak performance of these swales was attributed to the high flow velocities in the swales, soil compaction, steep slopes, and short grass height.

Another project in Durham, NC, monitored the performance of a carefully designed artificial swale that received runoff from a commercial parking lot. The project tracked 11 storms and concluded that particulate concentrations of heavy metals (Cu, Pb, Zn, and Cd) were reduced by approximately 50 percent. However, the swale proved largely ineffective for removing soluble nutrients.

The effectiveness of vegetated swales can be enhanced by adding check dams at approximately 17 meter (50 foot) increments along their length (See Figure 1). These dams maximize the retention time within the swale, decrease flow velocities, and promote particulate settling. Finally, the incorporation of vegetated filter strips parallel to the top of the channel banks can help to treat sheet flows entering the swale.

Only 9 studies have been conducted on all grassed channels designed for water quality (Table 1). The data suggest relatively high removal rates for some pollutants, but negative removals for some bacteria, and fair performance for phosphorus.

Removal Efficiencies (% Removal)							
Study	TSS	TP	TN	NO ₃	Metals	Bacteria	Type
Caltrans 2002	77	8	67	66	83-90	-33	dry swales
Goldberg 1993	67.8	4.5	-	31.4	42-62	-100	grassed channel
Seattle Metro and Washington Department of Ecology 1992	60	45	-	-25	2-16	-25	grassed channel
Seattle Metro and Washington Department of Ecology, 1992	83	29	-	-25	46-73	-25	grassed channel
Wang et al., 1981	80	-	-	-	70-80	-	dry swale
Dorman et al., 1989	98	18	-	45	37-81	-	dry swale
Harper, 1988	87	83	84	80	88-90	-	dry swale
Kercher et al., 1983	99	99	99	99	99	-	dry swale
Harper, 1988.	81	17	40	52	37-69	-	wet swale
Koon, 1995	67	39	-	9	-35 to 6	-	wet swale

While it is difficult to distinguish between different designs based on the small amount of available data, grassed channels generally have poorer removal rates than wet and dry swales, although some swales appear to export soluble phosphorus (Harper, 1988; Koon, 1995). It is not clear why swales export bacteria. One explanation is that bacteria thrive in the warm swale soils.

Siting Criteria

The suitability of a swale at a site will depend on land use, size of the area serviced, soil type, slope, imperviousness of the contributing watershed, and dimensions and slope of the swale system (Schueler et al., 1992). In general, swales can be used to serve areas of less than 10 acres, with slopes no greater than 5%. Use of natural topographic lows is encouraged and natural drainage courses should be regarded as significant local resources to be kept in use (Young et al., 1996).

Selection Criteria (NCTCOG, 1993)

- Comparable performance to wet basins
- Limited to treating a few acres
- Availability of water during dry periods to maintain vegetation
- Sufficient available land area

Research in the Austin area indicates that vegetated controls are effective at removing pollutants even when dormant. Therefore, irrigation is not required to maintain growth during dry periods, but may be necessary only to prevent the vegetation from dying.

The topography of the site should permit the design of a channel with appropriate slope and cross-sectional area. Site topography may also dictate a need for additional structural controls. Recommendations for longitudinal slopes range between 2 and 6 percent. Flatter slopes can be used, if sufficient to provide adequate conveyance. Steep slopes increase flow velocity, decrease detention time, and may require energy dissipating and grade check. Steep slopes also can be managed using a series of check dams to terrace the swale and reduce the slope to within acceptable limits. The use of check dams with swales also promotes infiltration.

Additional Design Guidelines

Most of the design guidelines adopted for swale design specify a minimum hydraulic residence time of 9 minutes. This criterion is based on the results of a single study conducted in Seattle, Washington (Seattle Metro and Washington Department of Ecology, 1992), and is not well supported. Analysis of the data collected in that study indicates that pollutant removal at a residence time of 5 minutes was not significantly different, although there is more variability in that data. Therefore, additional research in the design criteria for swales is needed. Substantial pollutant removal has also been observed for vegetated controls designed solely for conveyance (Barrett et al, 1998); consequently, some flexibility in the design is warranted.

Many design guidelines recommend that grass be frequently mowed to maintain dense coverage near the ground surface. Recent research (Colwell et al., 2000) has shown mowing frequency or grass height has little or no effect on pollutant removal.

Summary of Design Recommendations

- 1) The swale should have a length that provides a minimum hydraulic residence time of at least 10 minutes. The maximum bottom width should not exceed 10 feet unless a dividing berm is provided. The depth of flow should not exceed 2/3rds the height of the grass at the peak of the water quality design storm intensity. The channel slope should not exceed 2.5%.
- 2) A design grass height of 6 inches is recommended.
- 3) Regardless of the recommended detention time, the swale should be not less than 100 feet in length.
- 4) The width of the swale should be determined using Manning's Equation, at the peak of the design storm, using a Manning's n of 0.25.
- 5) The swale can be sized as both a treatment facility for the design storm and as a conveyance system to pass the peak hydraulic flows of the 100-year storm if it is located "on-line." The side slopes should be no steeper than 3:1 (H:V).
- 6) Roadside ditches should be regarded as significant potential swale/buffer strip sites and should be utilized for this purpose whenever possible. If flow is to be introduced through curb cuts, place pavement slightly above the elevation of the vegetated areas. Curb cuts should be at least 12 inches wide to prevent clogging.
- 7) Swales must be vegetated in order to provide adequate treatment of runoff. It is important to maximize water contact with vegetation and the soil surface. For general purposes, select fine, close-growing, water-resistant grasses. If possible, divert runoff (other than necessary irrigation) during the period of vegetation

establishment. Where runoff diversion is not possible, cover graded and seeded areas with suitable erosion control materials.

Maintenance

The useful life of a vegetated swale system is directly proportional to its maintenance frequency. If properly designed and regularly maintained, vegetated swales can last indefinitely. The maintenance objectives for vegetated swale systems include keeping up the hydraulic and removal efficiency of the channel and maintaining a dense, healthy grass cover.

Maintenance activities should include periodic mowing (with grass never cut shorter than the design flow depth), weed control, watering during drought conditions, reseeding of bare areas, and clearing of debris and blockages. Cuttings should be removed from the channel and disposed in a local composting facility. Accumulated sediment should also be removed manually to avoid concentrated flows in the swale. The application of fertilizers and pesticides should be minimal.

Another aspect of a good maintenance plan is repairing damaged areas within a channel. For example, if the channel develops ruts or holes, it should be repaired utilizing a suitable soil that is properly tamped and seeded. The grass cover should be thick; if it is not, reseed as necessary. Any standing water removed during the maintenance operation must be disposed to a sanitary sewer at an approved discharge location. Residuals (e.g., silt, grass cuttings) must be disposed in accordance with local or State requirements. Maintenance of grassed swales mostly involves maintenance of the grass or wetland plant cover. Typical maintenance activities are summarized below:

- Inspect swales at least twice annually for erosion, damage to vegetation, and sediment and debris accumulation preferably at the end of the wet season to schedule summer maintenance and before major fall runoff to be sure the swale is ready for winter. However, additional inspection after periods of heavy runoff is desirable. The swale should be checked for debris and litter, and areas of sediment accumulation.
- Grass height and mowing frequency may not have a large impact on pollutant removal. Consequently, mowing may only be necessary once or twice a year for safety or aesthetics or to suppress weeds and woody vegetation.
- Trash tends to accumulate in swale areas, particularly along highways. The need for litter removal is determined through periodic inspection, but litter should always be removed prior to mowing.
- Sediment accumulating near culverts and in channels should be removed when it builds up to 75 mm (3 in.) at any spot, or covers vegetation.
- Regularly inspect swales for pools of standing water. Swales can become a nuisance due to mosquito breeding in standing water if obstructions develop (e.g. debris accumulation, invasive vegetation) and/or if proper drainage slopes are not implemented and maintained.

Cost

Construction Cost

Little data is available to estimate the difference in cost between various swale designs. One study (SWRPC, 1991) estimated the construction cost of grassed channels at approximately \$0.25 per ft². This price does not include design costs or contingencies. Brown and Schueler (1997) estimate these costs at approximately 32 percent of construction costs for most stormwater management practices. For swales, however, these costs would probably be significantly higher since the construction costs are so low compared with other practices. A more realistic estimate would be a total cost of approximately \$0.50 per ft², which compares favorably with other stormwater management practices.

Table 2 Swale Cost Estimate (SEWRPC, 1991)

Component	Unit	Extent	Unit Cost			Total Cost		
			Low	Moderate	High	Low	Moderate	High
Mobilization / Demobilization-Light	Swale	1	\$107	\$274	\$441	\$107	\$274	\$441
Site Preparation								
Clearing ^a	Acre	0.5	\$2,200	\$3,800	\$5,400	\$1,100	\$1,900	\$2,700
Grubbing ^b	Acre	0.25	\$3,800	\$5,200	\$6,600	\$950	\$1,300	\$1,650
General Excavation ^c	Yd ²	372	\$2.10	\$3.70	\$5.30	\$781	\$1,376	\$1,972
Level and Till ^d	Yd ²	1,210	\$0.20	\$0.35	\$0.50	\$242	\$424	\$605
Sites Development								
Salvaged Topsoil	Yd ²	1,210	\$0.40	\$1.00	\$1.60	\$484	\$1,210	\$1,936
Seed, and Mulch ^e ..	Yd ²	1,210	\$1.20	\$2.40	\$3.60	\$1,452	\$2,904	\$4,356
Subtotal	--	--	--	--	--	\$5,116	\$9,388	\$13,680
Contingencies	Swale	1	25%	25%	25%	\$1,279	\$2,347	\$3,415
Total	--	--	--	--	--	\$6,395	\$11,735	\$17,075

Source: (SEWRPC, 1991)

- Note: Mobilization/demobilization refers to the organization and planning involved in establishing a vegetative swale.
- ^a Swale has a bottom width of 1.0 foot, a top width of 10 feet with 1:3 side slopes, and a 1,000-foot length.
- ^b Area cleared = (top width + 10 feet) x swale length.
- ^c Area grubbed = (top width x swale length).
- ^d Volume excavated = (0.67 x top width x swale depth) x swale length (parabolic cross-section).
- ^e Area tilled = (top width + $\frac{8(\text{swale depth})^2}{3(\text{top width})}$) x swale length (parabolic cross-section).
- ^f Area seeded = area cleared x 0.5.
- ^g Area sodded = area cleared x 0.5.

Vegetated Swale

TC-30

Table 3 Estimated Maintenance Costs (SEWRPC, 1991)

Component	Unit Cost	Swale Size (Depth and Top Width)		Comment
		1.5 Foot Depth, One-Foot Bottom Width, 10-Foot Top Width	3-Foot Depth, 3-Foot Bottom Width, 21-Foot Top Width	
Lawn Mowing	\$0.85 / 1,000 ft ² /mowing	\$0.14 /linear foot	\$0.21 /linear foot	Lawn maintenance area=(top width + 10 feet) x length. Mow eight times per year
General Lawn Care	\$9.00 / 1,000 ft ² / year	\$0.18 /linear foot	\$0.28 /linear foot	Lawn maintenance area = (top width + 10 feet) x length
Swale Debris and Litter Removal	\$0.10 / linear foot / year	\$0.10 /linear foot	\$0.10 /linear foot	--
Grass Reseeding with Mulch and Fertilizer	\$0.30 / yd ²	\$0.01 /linear foot	\$0.01 /linear foot	Area revegetated equals 1% of lawn maintenance area per year
Program Administration and Swale Inspection	\$0.15 / linear foot / year, plus \$25 / inspection	\$0.15 /linear foot	\$0.15 /linear foot	Inspect four times per year
Total	--	\$0.58 / linear foot	\$ 0.75 / linear foot	--

Maintenance Cost

Caltrans (2002) estimated the expected annual maintenance cost for a swale with a tributary area of approximately 2 ha at approximately \$2,700. Since almost all maintenance consists of mowing, the cost is fundamentally a function of the mowing frequency. Unit costs developed by SEWRPC are shown in Table 3. In many cases vegetated channels would be used to convey runoff and would require periodic mowing as well, so there may be little additional cost for the water quality component. Since essentially all the activities are related to vegetation management, no special training is required for maintenance personnel.

References and Sources of Additional Information

Barrett, Michael E., Walsh, Patrick M., Malina, Joseph F., Jr., Charbeneau, Randall J, 1998, "Performance of vegetative controls for treating highway runoff," *ASCE Journal of Environmental Engineering*, Vol. 124, No. 11, pp. 1121-1128.

Brown, W., and T. Schueler. 1997. *The Economics of Stormwater BMPs in the Mid-Atlantic Region*. Prepared for the Chesapeake Research Consortium, Edgewater, MD, by the Center for Watershed Protection, Ellicott City, MD.

Center for Watershed Protection (CWP). 1996. *Design of Stormwater Filtering Systems*. Prepared for the Chesapeake Research Consortium, Solomons, MD, and USEPA Region V, Chicago, IL, by the Center for Watershed Protection, Ellicott City, MD.

Colwell, Shanti R., Horner, Richard R., and Booth, Derek B., 2000. *Characterization of Performance Predictors and Evaluation of Mowing Practices in Biofiltration Swales*. Report to King County Land And Water Resources Division and others by Center for Urban Water Resources Management, Department of Civil and Environmental Engineering, University of Washington, Seattle, WA

Dorman, M.E., J. Hartigan, R.F. Steg, and T. Quasebarth. 1989. *Retention, Detention and Overland Flow for Pollutant Removal From Highway Stormwater Runoff. Vol. 1*. FHWA/RD 89/202. Federal Highway Administration, Washington, DC.

Goldberg. 1993. *Dayton Avenue Swale Biofiltration Study*. Seattle Engineering Department, Seattle, WA.

Harper, H. 1988. *Effects of Stormwater Management Systems on Groundwater Quality*. Prepared for Florida Department of Environmental Regulation, Tallahassee, FL, by Environmental Research and Design, Inc., Orlando, FL.

Kercher, W.C., J.C. Landon, and R. Massarelli. 1983. Grassy swales prove cost-effective for water pollution control. *Public Works*, 16: 53-55.

Koon, J. 1995. *Evaluation of Water Quality Ponds and Swales in the Issaquah/East Lake Sammamish Basins*. King County Surface Water Management, Seattle, WA, and Washington Department of Ecology, Olympia, WA.

Metzger, M. E., D. F. Messer, C. L. Beitia, C. M. Myers, and V. L. Kramer. 2002. The Dark Side Of Stormwater Runoff Management: Disease Vectors Associated With Structural BMPs. *Stormwater* 3(2): 24-39.

Oakland, P.H. 1983. An evaluation of stormwater pollutant removal

through grassed swale treatment. In *Proceedings of the International Symposium of Urban Hydrology, Hydraulics and Sediment Control*, Lexington, KY. pp. 173–182.

Occoquan Watershed Monitoring Laboratory. 1983. Final Report: *Metropolitan Washington Urban Runoff Project*. Prepared for the Metropolitan Washington Council of Governments, Washington, DC, by the Occoquan Watershed Monitoring Laboratory, Manassas, VA.

Pitt, R., and J. McLean. 1986. *Toronto Area Watershed Management Strategy Study: Humber River Pilot Watershed Project*. Ontario Ministry of Environment, Toronto, ON.

Schueler, T. 1997. Comparative Pollutant Removal Capability of Urban BMPs: A reanalysis. *Watershed Protection Techniques* 2(2):379–383.

Seattle Metro and Washington Department of Ecology. 1992. *Biofiltration Swale Performance: Recommendations and Design Considerations*. Publication No. 657. Water Pollution Control Department, Seattle, WA.

Southeastern Wisconsin Regional Planning Commission (SWRPC). 1991. *Costs of Urban Nonpoint Source Water Pollution Control Measures*. Technical report no. 31. Southeastern Wisconsin Regional Planning Commission, Waukesha, WI.

U.S. EPA, 1999, Stormwater Fact Sheet: Vegetated Swales, Report # 832-F-99-006 <http://www.epa.gov/owm/mtb/vegswale.pdf>, Office of Water, Washington DC.

Wang, T., D. Spyridakis, B. Mar, and R. Horner. 1981. *Transport, Deposition and Control of Heavy Metals in Highway Runoff*. FHWA-WA-RD-39-10. University of Washington, Department of Civil Engineering, Seattle, WA.

Washington State Department of Transportation, 1995, *Highway Runoff Manual*, Washington State Department of Transportation, Olympia, Washington.

Welborn, C., and J. Veenhuis. 1987. *Effects of Runoff Controls on the Quantity and Quality of Urban Runoff in Two Locations in Austin, TX*. USGS Water Resources Investigations Report No. 87-4004. U.S. Geological Survey, Reston, VA.

Yousef, Y., M. Wanielista, H. Harper, D. Pearce, and R. Tolbert. 1985. *Best Management Practices: Removal of Highway Contaminants By Roadside Swales*. University of Central Florida and Florida Department of Transportation, Orlando, FL.

Yu, S., S. Barnes, and V. Gerde. 1993. *Testing of Best Management Practices for Controlling Highway Runoff*. FHWA/VA-93-R16. Virginia Transportation Research Council, Charlottesville, VA.

Information Resources

Maryland Department of the Environment (MDE). 2000. *Maryland Stormwater Design Manual*. www.mde.state.md.us/environment/wma/stormwatermanual. Accessed May 22, 2001.

Reeves, E. 1994. Performance and Condition of Biofilters in the Pacific Northwest. *Watershed Protection Techniques* 1(3):117–119.

Seattle Metro and Washington Department of Ecology. 1992. *Biofiltration Swale Performance. Recommendations and Design Considerations*. Publication No. 657. Seattle Metro and Washington Department of Ecology, Olympia, WA.

USEPA 1993. *Guidance Specifying Management Measures for Sources of Nonpoint Pollution in Coastal Waters*. EPA-840-B-92-002. U.S. Environmental Protection Agency, Office of Water. Washington, DC.

Watershed Management Institute (WMI). 1997. *Operation, Maintenance, and Management of Stormwater Management Systems*. Prepared for U.S. Environmental Protection Agency, Office of Water. Washington, DC, by the Watershed Management Institute, Ingleside, MD.

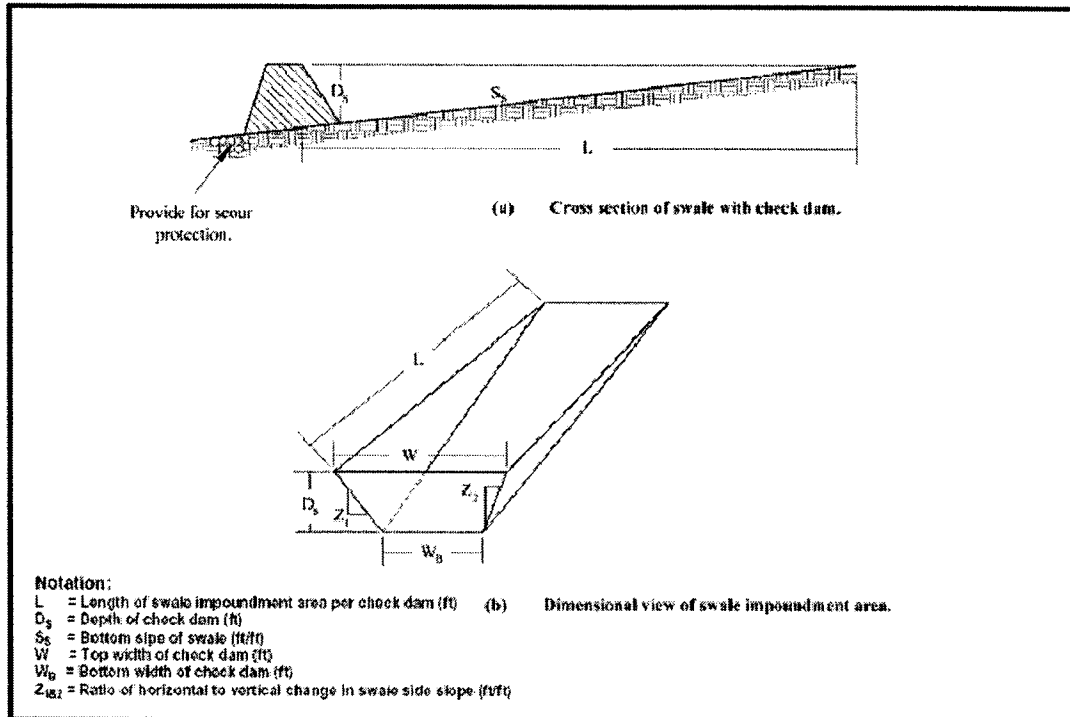

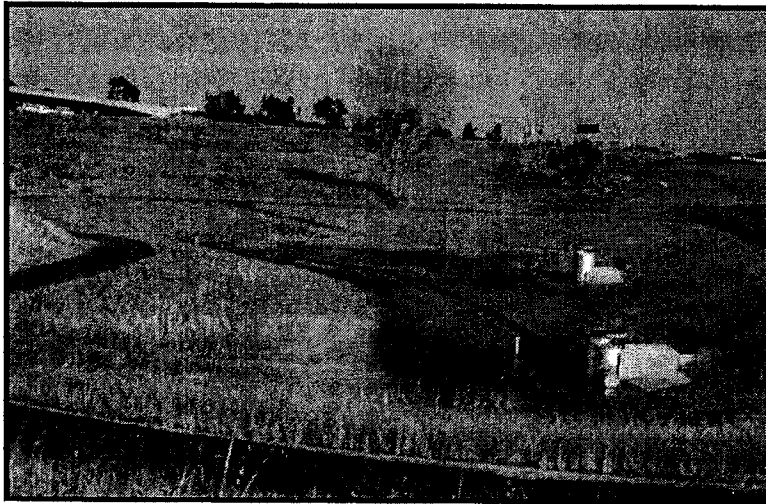

Design Considerations

- Tributary Area
- Area Required
- Hydraulic Head

Description

Dry extended detention ponds (a.k.a. dry ponds, extended detention basins, detention ponds, extended detention ponds) are basins whose outlets have been designed to detain the stormwater runoff from a water quality design storm for some minimum time (e.g., 48 hours) to allow particles and associated pollutants to settle. Unlike wet ponds, these facilities do not have a large permanent pool. They can also be used to provide flood control by including additional flood detention storage.

California Experience

Caltrans constructed and monitored 5 extended detention basins in southern California with design drain times of 72 hours. Four of the basins were earthen, less costly and had substantially better load reduction because of infiltration that occurred, than the concrete basin. The Caltrans study reaffirmed the flexibility and performance of this conventional technology. The small headloss and few siting constraints suggest that these devices are one of the most applicable technologies for stormwater treatment.

Advantages

- Due to the simplicity of design, extended detention basins are relatively easy and inexpensive to construct and operate.
- Extended detention basins can provide substantial capture of sediment and the toxics fraction associated with particulates.
- Widespread application with sufficient capture volume can provide significant control of channel erosion and enlargement caused by changes to flow frequency

Targeted Constituents

<input checked="" type="checkbox"/>	Sediment	▲
<input checked="" type="checkbox"/>	Nutrients	●
<input checked="" type="checkbox"/>	Trash	■
<input checked="" type="checkbox"/>	Metals	▲
<input checked="" type="checkbox"/>	Bacteria	▲
<input checked="" type="checkbox"/>	Oil and Grease	▲
<input checked="" type="checkbox"/>	Organics	▲

Legend (Removal Effectiveness)

- | | |
|----------|--------|
| ● Low | ■ High |
| ▲ Medium | |



relationships resulting from the increase of impervious cover in a watershed.

Limitations

- Limitation of the diameter of the orifice may not allow use of extended detention in watersheds of less than 5 acres (would require an orifice with a diameter of less than 0.5 inches that would be prone to clogging).
- Dry extended detention ponds have only moderate pollutant removal when compared to some other structural stormwater practices, and they are relatively ineffective at removing soluble pollutants.
- Although wet ponds can increase property values, dry ponds can actually detract from the value of a home due to the adverse aesthetics of dry, bare areas and inlet and outlet structures.

Design and Sizing Guidelines

- Capture volume determined by local requirements or sized to treat 85% of the annual runoff volume.
- Outlet designed to discharge the capture volume over a period of hours.
- Length to width ratio of at least 1.5:1 where feasible.
- Basin depths optimally range from 2 to 5 feet.
- Include energy dissipation in the inlet design to reduce resuspension of accumulated sediment.
- A maintenance ramp and perimeter access should be included in the design to facilitate access to the basin for maintenance activities and for vector surveillance and control.
- Use a draw down time of 48 hours in most areas of California. Draw down times in excess of 48 hours may result in vector breeding, and should be used only after coordination with local vector control authorities. Draw down times of less than 48 hours should be limited to BMP drainage areas with coarse soils that readily settle and to watersheds where warming may be determined to downstream fisheries.

Construction/Inspection Considerations

- Inspect facility after first large to storm to determine whether the desired residence time has been achieved.
- When constructed with small tributary area, orifice sizing is critical and inspection should verify that flow through additional openings such as bolt holes does not occur.

Performance

One objective of stormwater management practices can be to reduce the flood hazard associated with large storm events by reducing the peak flow associated with these storms. Dry extended detention basins can easily be designed for flood control, and this is actually the primary purpose of most detention ponds.

Dry extended detention basins provide moderate pollutant removal, provided that the recommended design features are incorporated. Although they can be effective at removing some pollutants through settling, they are less effective at removing soluble pollutants because of the absence of a permanent pool. Several studies are available on the effectiveness of dry extended detention ponds including one recently concluded by Caltrans (2002).

The load reduction is greater than the concentration reduction because of the substantial infiltration that occurs. Although the infiltration of stormwater is clearly beneficial to surface receiving waters, there is the potential for groundwater contamination. Previous research on the effects of incidental infiltration on groundwater quality indicated that the risk of contamination is minimal.

There were substantial differences in the amount of infiltration that were observed in the earthen basins during the Caltrans study. On average, approximately 40 percent of the runoff entering the unlined basins infiltrated and was not discharged. The percentage ranged from a high of about 60 percent to a low of only about 8 percent for the different facilities. Climatic conditions and local water table elevation are likely the principal causes of this difference. The least infiltration occurred at a site located on the coast where humidity is higher and the basin invert is within a few meters of sea level. Conversely, the most infiltration occurred at a facility located well inland in Los Angeles County where the climate is much warmer and the humidity is less, resulting in lower soil moisture content in the basin floor at the beginning of storms.

Vegetated detention basins appear to have greater pollutant removal than concrete basins. In the Caltrans study, the concrete basin exported sediment and associated pollutants during a number of storms. Export was not as common in the earthen basins, where the vegetation appeared to help stabilize the retained sediment.

Siting Criteria

Dry extended detention ponds are among the most widely applicable stormwater management practices and are especially useful in retrofit situations where their low hydraulic head requirements allow them to be sited within the constraints of the existing storm drain system. In addition, many communities have detention basins designed for flood control. It is possible to modify these facilities to incorporate features that provide water quality treatment and/or channel protection. Although dry extended detention ponds can be applied rather broadly, designers need to ensure that they are feasible at the site in question. This section provides basic guidelines for siting dry extended detention ponds.

In general, dry extended detention ponds should be used on sites with a minimum area of 5 acres. With this size catchment area, the orifice size can be on the order of 0.5 inches. On smaller sites, it can be challenging to provide channel or water quality control because the orifice diameter at the outlet needed to control relatively small storms becomes very small and thus prone to clogging. In addition, it is generally more cost-effective to control larger drainage areas due to the economies of scale.

Extended detention basins can be used with almost all soils and geology, with minor design adjustments for regions of rapidly percolating soils such as sand. In these areas, extended detention ponds may need an impermeable liner to prevent ground water contamination.

The base of the extended detention facility should not intersect the water table. A permanently wet bottom may become a mosquito breeding ground. Research in Southwest Florida (Santana et al., 1994) demonstrated that intermittently flooded systems, such as dry extended detention ponds, produce more mosquitoes than other pond systems, particularly when the facilities remained wet for more than 3 days following heavy rainfall.

A study in Prince George's County, Maryland, found that stormwater management practices can increase stream temperatures (Galli, 1990). Overall, dry extended detention ponds increased temperature by about 5°F. In cold water streams, dry ponds should be designed to detain stormwater for a relatively short time (i.e., 24 hours) to minimize the amount of warming that occurs in the basin.

Additional Design Guidelines

In order to enhance the effectiveness of extended detention basins, the dimensions of the basin must be sized appropriately. Merely providing the required storage volume will not ensure maximum constituent removal. By effectively configuring the basin, the designer will create a long flow path, promote the establishment of low velocities, and avoid having stagnant areas of the basin. To promote settling and to attain an appealing environment, the design of the basin should consider the length to width ratio, cross-sectional areas, basin slopes and pond configuration, and aesthetics (Young et al., 1996).

Energy dissipation structures should be included for the basin inlet to prevent resuspension of accumulated sediment. The use of stilling basins for this purpose should be avoided because the standing water provides a breeding area for mosquitoes.

Extended detention facilities should be sized to completely capture the water quality volume. A micropool is often recommended for inclusion in the design and one is shown in the schematic diagram. These small permanent pools greatly increase the potential for mosquito breeding and complicate maintenance activities; consequently, they are not recommended for use in California.

A large aspect ratio may improve the performance of detention basins; consequently, the outlets should be placed to maximize the flowpath through the facility. The ratio of flowpath length to width from the inlet to the outlet should be at least 1.5:1 (L:W) where feasible. Basin depths optimally range from 2 to 5 feet.

The facility's drawdown time should be regulated by an orifice or weir. In general, the outflow structure should have a trash rack or other acceptable means of preventing clogging at the entrance to the outflow pipes. The outlet design implemented by Caltrans in the facilities constructed in San Diego County used an outlet riser with orifices

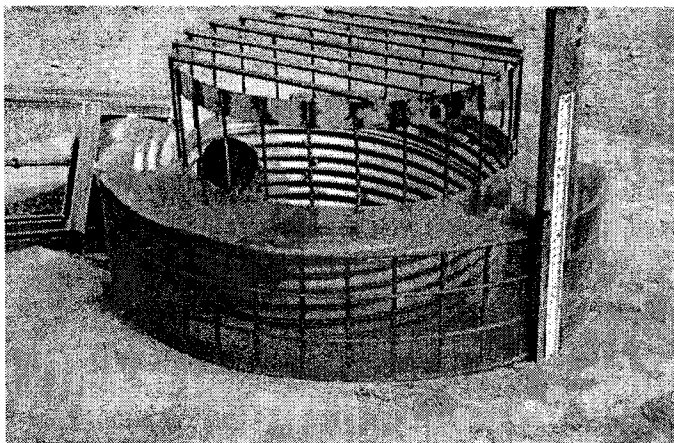

Figure 1
Example of Extended Detention Outlet Structure

sized to discharge the water quality volume, and the riser overflow height was set to the design storm elevation. A stainless steel screen was placed around the outlet riser to ensure that the orifices would not become clogged with debris. Sites either used a separate riser or broad crested weir for overflow of runoff for the 25 and greater year storms. A picture of a typical outlet is presented in Figure 1.

The outflow structure should be sized to allow for complete drawdown of the water quality volume in 72 hours. No more than 50% of the water quality volume should drain from the facility within the first 24 hours. The outflow structure can be fitted with a valve so that discharge from the basin can be halted in case of an accidental spill in the watershed.

Summary of Design Recommendations

- (1) **Facility Sizing** - The required water quality volume is determined by local regulations or the basin should be sized to capture and treat 85% of the annual runoff volume. See Section 5.5.1 of the handbook for a discussion of volume-based design.

Basin Configuration – A high aspect ratio may improve the performance of detention basins; consequently, the outlets should be placed to maximize the flowpath through the facility. The ratio of flowpath length to width from the inlet to the outlet should be at least 1.5:1 (L:W). The flowpath length is defined as the distance from the inlet to the outlet as measured at the surface. The width is defined as the mean width of the basin. Basin depths optimally range from 2 to 5 feet. The basin may include a sediment forebay to provide the opportunity for larger particles to settle out.

A micropool should not be incorporated in the design because of vector concerns. For online facilities, the principal and emergency spillways must be sized to provide 1.0 foot of freeboard during the 25-year event and to safely pass the flow from 100-year storm.

- (2) **Pond Side Slopes** - Side slopes of the pond should be 3:1 (H:V) or flatter for grass stabilized slopes. Slopes steeper than 3:1 (H:V) must be stabilized with an appropriate slope stabilization practice.
- (3) **Basin Lining** – Basins must be constructed to prevent possible contamination of groundwater below the facility.
- (4) **Basin Inlet** – Energy dissipation is required at the basin inlet to reduce resuspension of accumulated sediment and to reduce the tendency for short-circuiting.
- (5) **Outflow Structure** - The facility's drawdown time should be regulated by a gate valve or orifice plate. In general, the outflow structure should have a trash rack or other acceptable means of preventing clogging at the entrance to the outflow pipes.

The outflow structure should be sized to allow for complete drawdown of the water quality volume in 72 hours. No more than 50% of the water quality volume should drain from the facility within the first 24 hours. The outflow structure should be fitted with a valve so that discharge from the basin can be halted in case of an accidental spill in the watershed. This same valve also can be used to regulate the rate of discharge from the basin.

The discharge through a control orifice is calculated from:

$$Q = CA(2g(H-H_o))^{0.5}$$

where: Q = discharge (ft³/s)
 C = orifice coefficient
 A = area of the orifice (ft²)
 g = gravitational constant (32.2)
 H = water surface elevation (ft)
 H_o = orifice elevation (ft)

Recommended values for C are 0.66 for thin materials and 0.80 when the material is thicker than the orifice diameter. This equation can be implemented in spreadsheet form with the pond stage/volume relationship to calculate drain time. To do this, use the initial height of the water above the orifice for the water quality volume. Calculate the discharge and assume that it remains constant for approximately 10 minutes. Based on that discharge, estimate the total discharge during that interval and the new elevation based on the stage volume relationship. Continue to iterate until H is approximately equal to H_o. When using multiple orifices the discharge from each is summed.

- (6) Splitter Box - When the pond is designed as an offline facility, a splitter structure is used to isolate the water quality volume. The splitter box, or other flow diverting approach, should be designed to convey the 25-year storm event while providing at least 1.0 foot of freeboard along pond side slopes.
- (7) Erosion Protection at the Outfall - For online facilities, special consideration should be given to the facility's outfall location. Flared pipe end sections that discharge at or near the stream invert are preferred. The channel immediately below the pond outfall should be modified to conform to natural dimensions, and lined with large stone riprap placed over filter cloth. Energy dissipation may be required to reduce flow velocities from the primary spillway to non-erosive velocities.
- (8) Safety Considerations - Safety is provided either by fencing of the facility or by managing the contours of the pond to eliminate dropoffs and other hazards. Earthen side slopes should not exceed 3:1 (H:V) and should terminate on a flat safety bench area. Landscaping can be used to impede access to the facility. The primary spillway opening must not permit access by small children. Outfall pipes above 48 inches in diameter should be fenced.

Maintenance

Routine maintenance activity is often thought to consist mostly of sediment and trash and debris removal; however, these activities often constitute only a small fraction of the maintenance hours. During a recent study by Caltrans, 72 hours of maintenance was performed annually, but only a little over 7 hours was spent on sediment and trash removal. The largest recurring activity was vegetation management, routine mowing. The largest absolute number of hours was associated with vector control because of mosquito breeding that occurred in the stilling basins (example of standing water to be avoided) installed as energy dissipaters. In most cases, basic housekeeping practices such as removal of debris accumulations and vegetation

management to ensure that the basin dewatered completely in 48-72 hours is sufficient to prevent creating mosquito and other vector habitats.

Consequently, maintenance costs should be estimated based primarily on the mowing frequency and the time required. Mowing should be done at least annually to avoid establishment of woody vegetation, but may need to be performed much more frequently if aesthetics are an important consideration.

Typical activities and frequencies include:

- Schedule semiannual inspection for the beginning and end of the wet season for standing water, slope stability, sediment accumulation, trash and debris, and presence of burrows.
- Remove accumulated trash and debris in the basin and around the riser pipe during the semiannual inspections. The frequency of this activity may be altered to meet specific site conditions.
- Trim vegetation at the beginning and end of the wet season and inspect monthly to prevent establishment of woody vegetation and for aesthetic and vector reasons.
- Remove accumulated sediment and re-grade about every 10 years or when the accumulated sediment volume exceeds 10 percent of the basin volume. Inspect the basin each year for accumulated sediment volume.

Cost

Construction Cost

The construction costs associated with extended detention basins vary considerably. One recent study evaluated the cost of all pond systems (Brown and Schueler, 1997). Adjusting for inflation, the cost of dry extended detention ponds can be estimated with the equation:

$$C = 12.4V^{0.760}$$

where: C = Construction, design, and permitting cost, and
V = Volume (ft³).

Using this equation, typical construction costs are:

\$ 41,600 for a 1 acre-foot pond

\$ 239,000 for a 10 acre-foot pond

\$ 1,380,000 for a 100 acre-foot pond

Interestingly, these costs are generally slightly higher than the predicted cost of wet ponds (according to Brown and Schueler, 1997) on a cost per total volume basis, which highlights the difficulty of developing reasonably accurate construction estimates. In addition, a typical facility constructed by Caltrans cost about \$160,000 with a capture volume of only 0.3 ac-ft.

An economic concern associated with dry ponds is that they might detract slightly from the value of adjacent properties. One study found that dry ponds can actually detract from the

perceived value of homes adjacent to a dry pond by between 3 and 10 percent (Emmerling-Dinovo, 1995).

Maintenance Cost

For ponds, the annual cost of routine maintenance is typically estimated at about 3 to 5 percent of the construction cost (EPA website). Alternatively, a community can estimate the cost of the maintenance activities outlined in the maintenance section. Table 1 presents the maintenance costs estimated by Caltrans based on their experience with five basins located in southern California. Again, it should be emphasized that the vast majority of hours are related to vegetation management (mowing).

Table 1 Estimated Average Annual Maintenance Effort

Activity	Labor Hours	Equipment & Material (\$)	Cost
Inspections	4	7	183
Maintenance	49	126	2282
Vector Control	0	0	0
Administration	3	0	132
Materials	-	535	535
Total	56	\$668	\$3,132

References and Sources of Additional Information

Brown, W., and T. Schueler. 1997. *The Economics of Stormwater BMPs in the Mid-Atlantic Region*. Prepared for Chesapeake Research Consortium. Edgewater, MD. Center for Watershed Protection. Ellicott City, MD.

Denver Urban Drainage and Flood Control District. 1992. *Urban Storm Drainage Criteria Manual—Volume 3: Best Management Practices*. Denver, CO.

Emmerling-Dinovo, C. 1995. Stormwater Detention Basins and Residential Locational Decisions. *Water Resources Bulletin* 31(3): 515–521

Galli, J. 1990. *Thermal Impacts Associated with Urbanization and Stormwater Management Best Management Practices*. Metropolitan Washington Council of Governments. Prepared for Maryland Department of the Environment, Baltimore, MD.

GKY, 1989, *Outlet Hydraulics of Extended Detention Facilities* for the Northern Virginia Planning District Commission.

MacRae, C. 1996. Experience from Morphological Research on Canadian Streams: Is Control of the Two-Year Frequency Runoff Event the Best Basis for Stream Channel Protection? In *Effects of Watershed Development and Management on Aquatic Ecosystems*. American Society of Civil Engineers. Edited by L. Roesner. Snowbird, UT. pp. 144–162.

Maryland Dept of the Environment, 2000, Maryland Stormwater Design Manual: Volumes 1 & 2, prepared by MDE and Center for Watershed Protection.

<http://www.mde.state.md.us/environment/wma/stormwatermanual/index.html>

Metzger, M. E., D. F. Messer, C. L. Beitia, C. M. Myers, and V. L. Kramer. 2002. The Dark Side Of Stormwater Runoff Management: Disease Vectors Associated With Structural BMPs. *Stormwater* 3(2): 24-39.

Santana, F., J. Wood, R. Parsons, and S. Chamberlain. 1994. Control of Mosquito Breeding in Permitted Stormwater Systems. Prepared for Southwest Florida Water Management District, Brooksville, FL.

Schueler, T. 1997. Influence of Ground Water on Performance of Stormwater Ponds in Florida. *Watershed Protection Techniques* 2(4):525-528.

Watershed Management Institute (WMI). 1997. *Operation, Maintenance, and Management of Stormwater Management Systems*. Prepared for U.S. Environmental Protection Agency, Office of Water. Washington, DC.

Young, G.K., et al., 1996, *Evaluation and Management of Highway Runoff Water Quality*, Publication No. FHWA-PD-96-032, U.S. Department of Transportation, Federal Highway Administration, Office of Environment and Planning.

Information Resources

Center for Watershed Protection (CWP), Environmental Quality Resources, and Loiederman Associates. 1997. *Maryland Stormwater Design Manual*. Draft. Prepared for Maryland Department of the Environment, Baltimore, MD.

Center for Watershed Protection (CWP). 1997. *Stormwater BMP Design Supplement for Cold Climates*. Prepared for U.S. Environmental Protection Agency, Office of Wetlands, Oceans and Watersheds. Washington, DC.

U.S. Environmental Protection Agency (USEPA). 1993. *Guidance Specifying Management Measures for Sources of Nonpoint Pollution in Coastal Waters*. EPA-840-B-92-002. U.S. Environmental Protection Agency, Office of Water, Washington, DC.

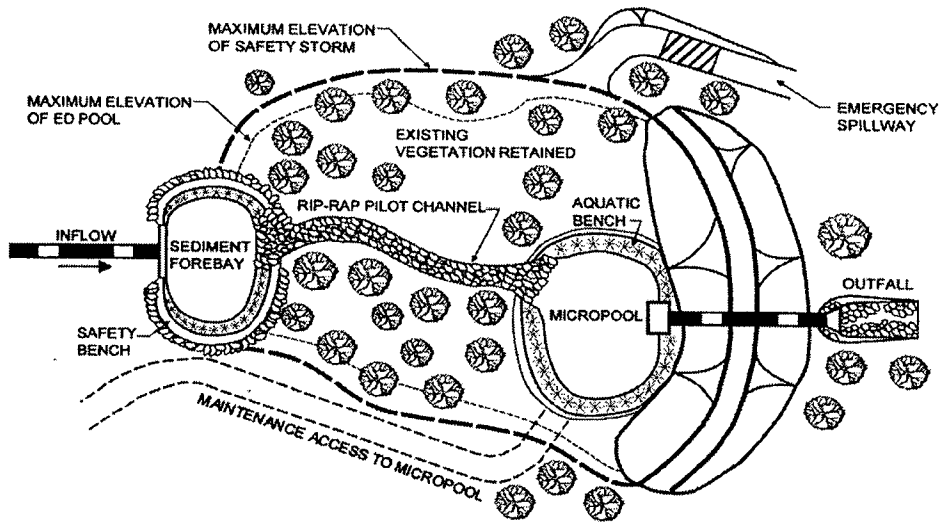

PLAN VIEW

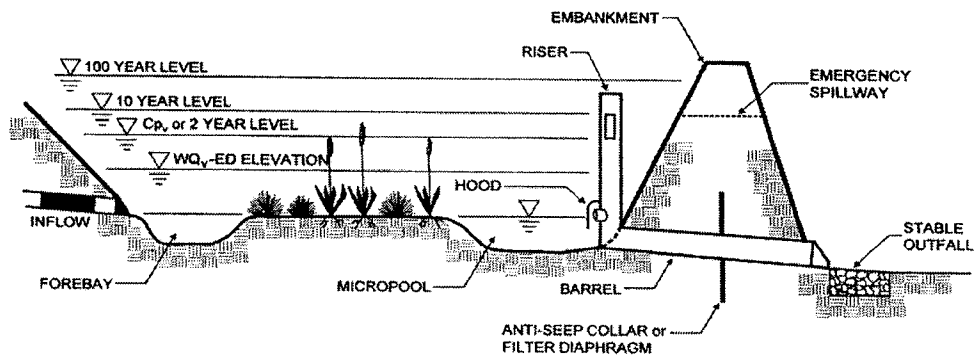

PROFILE

Schematic of an Extended Detention Basin (MDE, 2000)

*Drainage Study
for the Otay Mesa
Community Plan Update*

June, 2006

Prepared for:
MNA Consulting
427 C Street, Suite 308
San Diego CA 92101

Prepared by:
Kimley-Horn and Associates, Inc.
517 Fourth Avenue, Suite 301
San Diego CA 92101

TABLE OF CONTENTS

I. BACKGROUND..... 1

II. EXISTING DRAINAGE FACILITIES 3

III. HYDROLOGIC ANALYSIS 5

IV. HYDRAULIC ANALYSIS..... 9

V. PROPOSED DRAINAGE FACILITIES..... 12

VI. PROPOSED DRAINAGE ALTERNATIVES 14

VII. RECOMMENDED DRAINAGE DESIGN CRITERIA..... 20

VIII. STORM WATER QUALITY REQUIREMENTS 21

LIST OF EXHIBITS

EXISTING DRAINAGE FACILITIES MAP 4

WATERSHED MAP 7

AES SUMMARY TABLE 8

HEC-RAS MODEL 10

PROPOSED DRAINAGE FACILITIES MAP..... 13

COST ESTIMATE 16

PRELIMINARY DESIGN PLAN: LA MEDIA CHANNEL AND BORDER DETENTION BASIN 17

PRELIMINARY DESIGN: CHANNEL CROSS SECTION 18

PROPERTY OWNERSHIP MAP 19

RECOMMENDED STORM WATER POLICIES 23

EXAMPLE OF PERMANENT STORM WATER BEST MANAGEMENT PRACTICES 24

STORM WATER REQUIREMENTS CHECKLIST 25

APPENDICES

APPENDIX A AES HYDROLOGY CALCULATIONS

APPENDIX B HEC-1 MODEL

I. BACKGROUND

This report has been prepared as an appendix to the Otay Mesa Community Plan update EIR. Its purpose is to provide a summary of the existing drainage situation and facilities and proposed future facilities, including alternatives for draining the large central watershed. In addition, this report presents recommendations for drainage design criteria and storm water quality requirements for each of the watersheds on the Mesa.

For most of its early history, Otay Mesa was used for agriculture and farming was the primary land use. As industrial and commercial development started taking place in the 1960s, the City of San Diego recognized the need for a comprehensive drainage Master Plan for the Mesa. Because most of the Mesa drains to the South into Mexico, there was concern that the new development would increase the runoff crossing the border. The City needed to establish criteria for the new development such that there was no increase in runoff as a result of the new construction.

In May of 1987, the City Council approved a contract to prepare the Otay Mesa Drainage Master Plan. In August of 1987, the City published a Notice to "All Private Engineers" that established "Drainage Requirements for Development in Otay Mesa" (attached). The Master Plan was published in January, 1988, and included a proposed concrete Channel from Airway Road to Siempre Viva Road that followed the existing drainage channel.

The Master plan was updated with the "Otay Mesa Drainage Study" published in August, 1999. The most significant recommendation change was moving the proposed new channel from the creek alignment to a new location directly adjacent to La Media Road and Siempre Viva Road.

Reproduction of 1987 NOTICE from Engineering and Development Department

NOTICE

Date: August 7, 1987

To: All Private Engineers

From: Subdivision Engineer

Subject: Drainage requirements for development in Otay Mesa

In order to minimize the effects of increased storm water runoff in Mexico, due to development of property in Otay Mesa, all property in Otay Mesa that is within the water shed that drains into Mexico, shall be developed with the following requirements:

1. Each property owner shall provide storm water detention facilities so that there will be no increase in the rate of runoff due to development of the property.
2. The detention facilities shall be designed so that the rate of runoff from the property will not be greater after development than it was before development for a 5 year, 10 year, 25 year and 50 year storm.
3. All drainage facilities crossing four-lane major or higher classification streets shall be designed for a Q100 (existing). Other facilities, except the major channel referred to in paragraph 5, may be designed for Q50 (existing).
4. The Drainage Design Manual shall be used as guidelines for design of drainage facilities and computing design discharges.
5. The City Engineer's Office, Flood Control Section, is preparing a preliminary plan for the main north-south channel from Otay Mesa Road near La Media to the Mexican Border. The preliminary design will include the design "Q" (Q100 existing), the invert grade, and the water surface elevation at the major road crossings.

C.R. Lockhead
Subdivision Engineer

II. EXISTING DRAINAGE FACILITIES

Information was collected for existing drainage and flood control facilities on Otay Mesa through as-built plans, SanGIS maps, and site visits. Most of the existing drainage facilities were constructed as part of the private development that is taking place on the Mesa. Many of these facilities are not continuous because of the piecemeal nature of the development. This creates challenges for the subsequent developers that need to tie into the existing facilities. Many of the existing facilities are temporary.

Most of the development to-date has occurred in the East Watershed, which therefore includes most of the existing drainage facilities on the Mesa. The existing system is a combination of storm drains, improved channels, and detention basins, which in many areas discharge to natural drainage paths that do not have adequate hydraulic capacity.

The “Existing Drainage Facilities” drawing shows the facilities as-of the date of this report. The area is developing rapidly, and therefore new facilities are continuously being constructed. There are currently no dedicated drainage rights-of-way on the Mesa. Many of the projects, as they were mapped and constructed, dedicated portions of the properties to the city as drainage easements or flood water storage easements. Eventually, the systems and their easements will be continuous.

III. HYDROLOGIC ANALYSIS

The Otay Mesa Study area is shown on the Watershed Map, and includes all of the Mesa area within the City of San Diego divided into five watersheds (with the exception of the far northwest arm of the Mesa, which is fully developed).

Watersheds	Acres	mi ²
West Perimeter Watershed	258	0.40
West Watershed	2,190	3.42
North Perimeter Watershed	590	0.92
East Watershed	3,864	6.04
Border Crossing Watershed	<u>223</u>	<u>0.35</u>
TOTAL	7,125	11.13

Most of the Mesa slopes from North to South, with the flow entering Mexico at several points. The northern and western perimeters of the Mesa flow into the adjacent Canyons. These perimeter watersheds are divided into several independent smaller watersheds. The watershed boundaries on the Mesa are not well defined because the Mesa is so flat. There are very few defined natural drainage paths, with much of the runoff sheet-flowing across the Mesa. The watershed boundaries shown are based on field investigations and best available mapping, but the actual drainage boundaries may be very different.

The only watershed that has been studied significantly from a drainage perspective is the East Watershed. Hydrologic models have been prepared for both of the previous drainage studies. The peak flows calculated in the two studies are different, primarily because of different assumptions relative to developed area, proposed drainage facilities, and watershed areas. The East Watershed includes a large area of unincorporated County property. The hydrologic model assumed the same industrial development for the unincorporated area. If land uses change in the County area, it may change the runoff rates. The differences for the concentration point at the border are shown below.

Q100 at Border East Watershed		
	Area (mi ²)	Q100(cfs)
1988 Study	5.72	5,050
1999 Study	6.63	3,529
2004 CPU	6.78	3,673

As part of this study, new hydrologic models have been prepared for the main watersheds which flow into the Tijuana River. For the East Watershed, HEC-1 has been used, since both previous studies used this model. For the other watersheds, the standard City of San Diego Modified Rational Method (AES) has been used. The results of these analyses are shown in the table below.

Hydrologic Analysis Summary			
	Area (mi ²)	Q50(cfs)	Q100(cfs)
West Perimeter Watershed	0.40	170	444
West Watershed	3.42	672	1,676
East Watershed	6.78	1,280	3,673
	10.60	2,122	5,793

In addition to the above flows, the Spring Canyon open space area contributes 109 cfs (Q50) and 257 cfs (Q100) from 1.2 mi². Since the Tijuana River Watershed is a water-quality impacted watershed, the quality and quantity of flow will need to be addressed before additional development takes place.

IV. HYDRAULIC ANALYSIS

Most of the Mesa is very flat, resulting in local flooding during storms at the low points and along some drainage ditches. The only significant creek on the Mesa is the main channel in the East Watershed, Otay Mesa Creek, which flows from North to South along La Media Road and crosses the border into Mexico just north of the Tijuana Airport.

A HEC-RAS hydraulic model was prepared for this channel from the border north to Otay Mesa Road. The purpose of this model was to identify the 100-year floodplain for this reach for present conditions. The proposed future drainage project along this alignment will be designed to contain the 100-year flow, reducing or eliminating flooding impacts to adjacent properties.

The HEC-RAS model was also used to size the proposed new channel from Airway Road to just south of Siempre Viva Road. Several alternative cross-sections were modeled to reflect input on the environmental aspects of the channel.

A significant tributary to the main channel enters just upstream of the Siempre Viva Road crossing. This tributary conveys flow from the De La Fuente Business Park and the Siempre Viva Business Park. The existing channel from La Media Road to the proposed main channel is approximately 15 feet wide and 4 feet deep, with a hydraulic capacity of approximately 120 cfs. The 100 year flow in this channel is 1116 cfs. A proposed new channel has a 50 ft bottom width with 1.5:1.0 side slopes and will convey the 100 year flow. A double 10' x 4.5' RCB will also be required for the flow under La Media Road. The cost estimate does not include these facilities.

HEC-RAS Plan: Plan 01 River: Otay Mesa Draina Reach: Channel Profile: PF 1

Reach	River Sta	Profile	Q Total (cfs)	Min. Ch El (ft)	W.S. Elev (ft)	Crit W.S. (ft)	E.G. Elev (ft)	E.G. Slope (ft/ft)	Vel Chnl (ft/s)	Flow Area (sq ft)	Top Width (ft)	Froude # Chl
Channel	5500	PF 1	2500.00	464.60	471.08		471.16	0.002743	2.33	1073.59	200.00	0.18
Channel	5350	PF 1	2500.00	464.23	470.69		470.76	0.002572	2.16	1279.19	335.44	0.17
Channel	5100	PF 1	2500.00	463.60	470.06		470.12	0.002591	2.17	1275.99	335.16	0.17
Channel	4800	PF 1	2500.00	462.85	469.27		469.33	0.002666	2.19	1263.56	334.04	0.18
Channel	4500	PF 1	2500.00	462.10	468.51		468.56	0.002430	2.08	1358.84	378.24	0.17
Channel	4200	PF 1	2500.00	461.35	467.79		467.85	0.002365	2.07	1371.79	379.61	0.17
Channel	3900	PF 1	2500.00	460.60	467.09		467.15	0.002266	2.04	1392.50	381.79	0.16
Channel	3600	PF 1	2500.00	459.85	466.30		466.37	0.002969	2.32	1153.04	281.59	0.19
Channel	3300	PF 1	2500.00	459.10	465.33		465.42	0.003423	2.41	1109.99	285.62	0.20
Channel	3050	PF 1	3000.00	458.48	463.50		463.74	0.014532	4.06	777.90	261.33	0.39
Channel	2900	PF 1	3000.00	458.10	463.23	461.14	463.61	0.000245	4.97	603.31	222.92	0.41
Channel	2850	PF 1	3000.00	457.60	462.74	461.24	463.55	0.000521	7.22	415.32	168.05	0.58
Channel	2750	Culvert										
Channel	2640	PF 1	3000.00	455.59	462.07	458.95	462.52	0.011957	5.38	557.46	183.64	0.37
Channel	2500	PF 1	3000.00	455.38	461.81		461.87	0.001846	2.07	1492.22	277.64	0.15
Channel	2300	PF 1	3000.00	455.08	461.31		461.40	0.003272	2.45	1261.91	277.98	0.19
Channel	2100	PF 1	3000.00	454.78	460.34		460.48	0.006864	3.05	1006.36	275.43	0.27
Channel	2050	PF 1	3000.00	454.70	460.11		460.21	0.003838	2.56	1191.75	275.37	0.21
Channel	2000	PF 1	3000.00	454.63	460.00	456.55	460.06	0.002196	2.06	1582.39	378.00	0.16

Channel 1-3-05 Plan: Plan 01 1/3/2005

Olay Mesa Drains Channel

Legend	
EG PF 1	(Dotted pattern)
WS PF 1	(Horizontal line pattern)
Crit PF 1	(Vertical line pattern)
Ground	(Solid black)

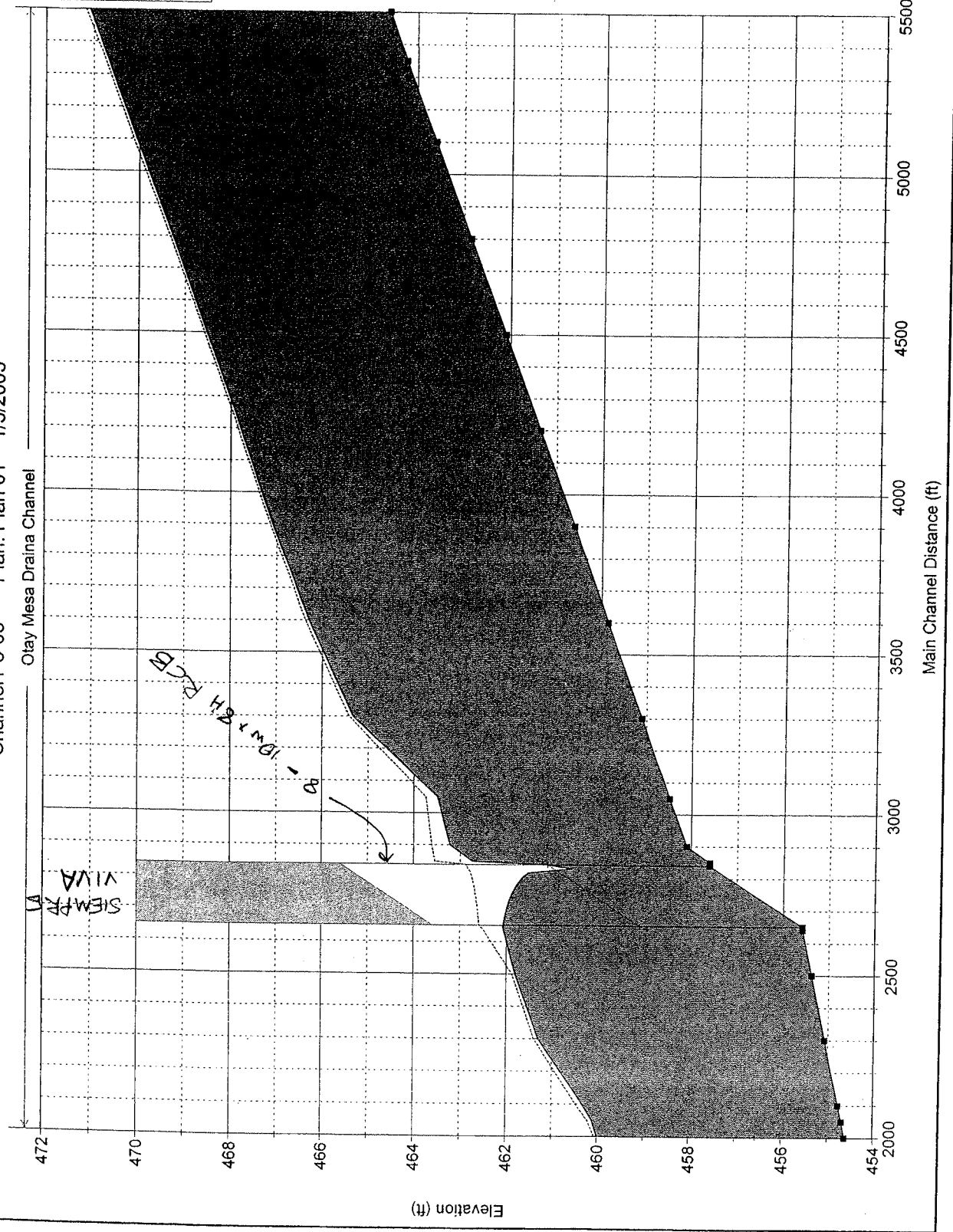

Channel1-3-05 Plan: Plan 01 1/4/2005
RS = 5500

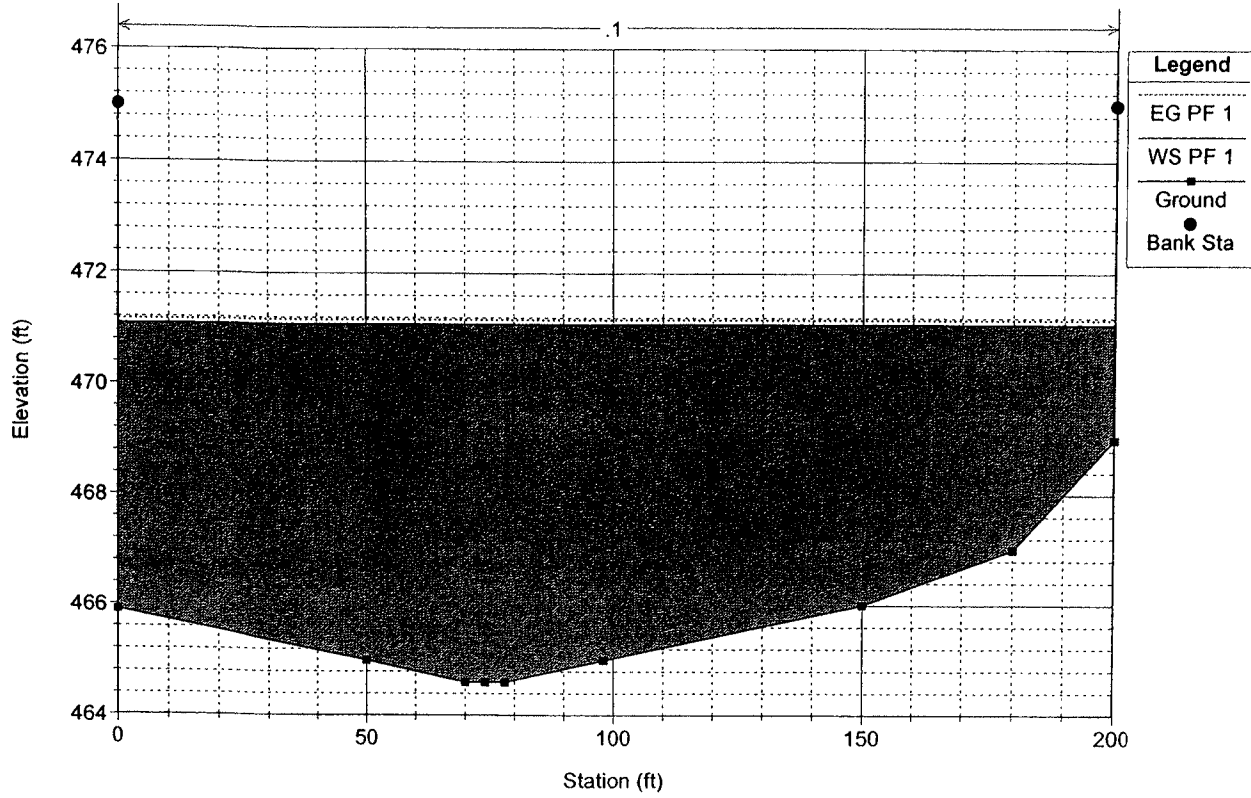

Channel1-3-05 Plan: Plan 01 1/4/2005
RS = 5350

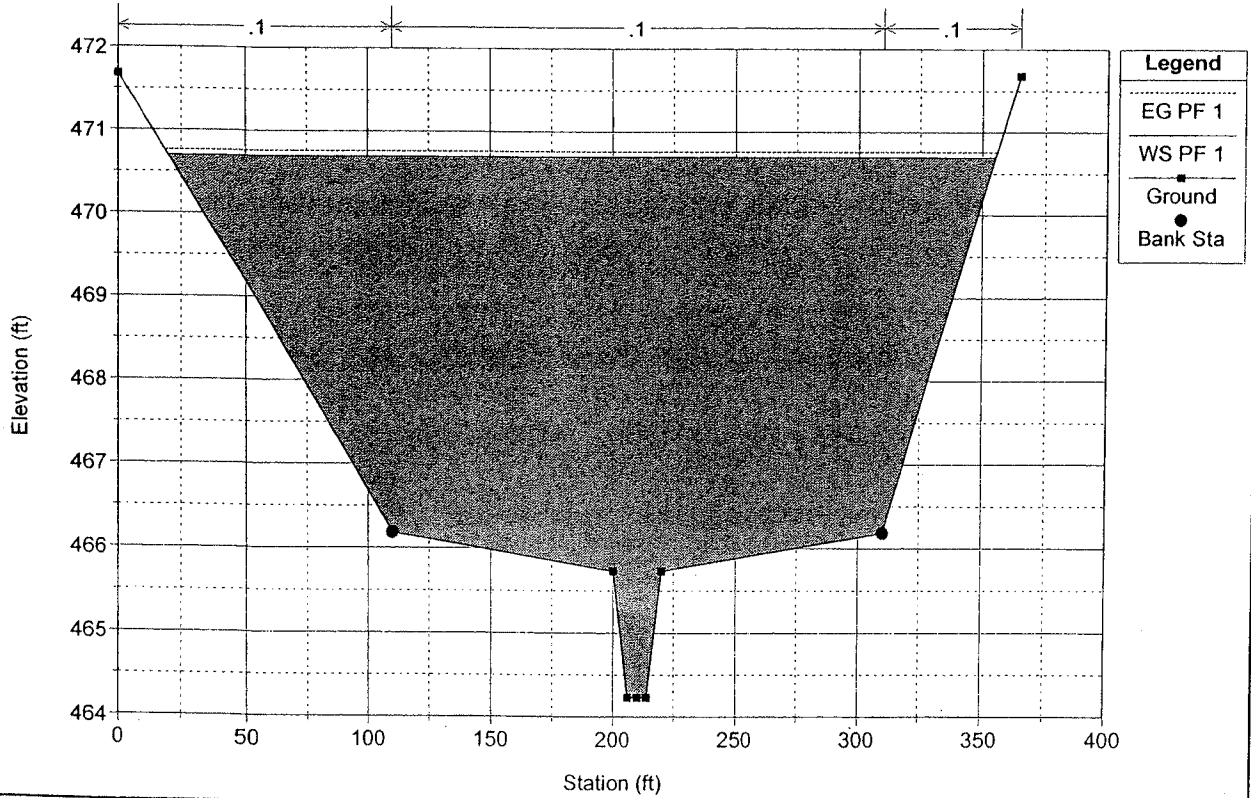

Channel1-3-05 Plan: Plan 01 1/4/2005
RS = 5100

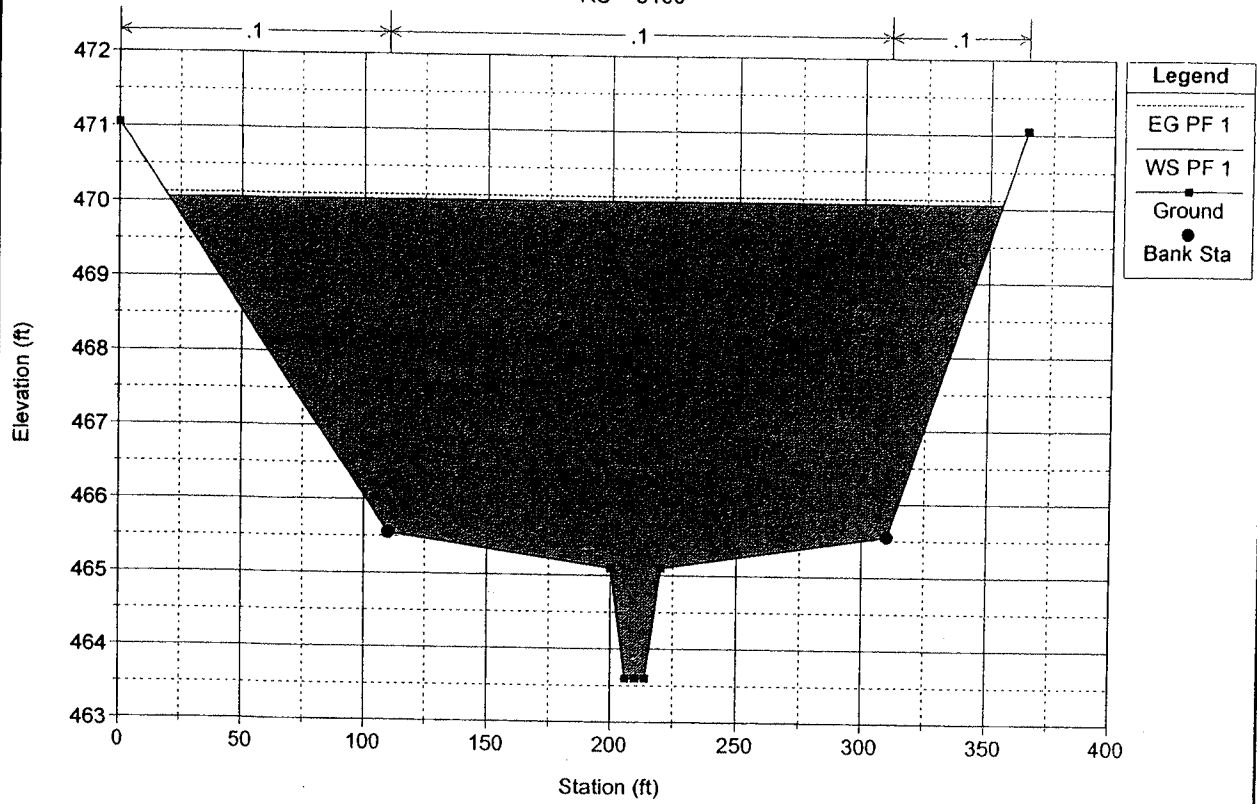

Channel1-3-05 Plan: Plan 01 1/4/2005
RS = 4800

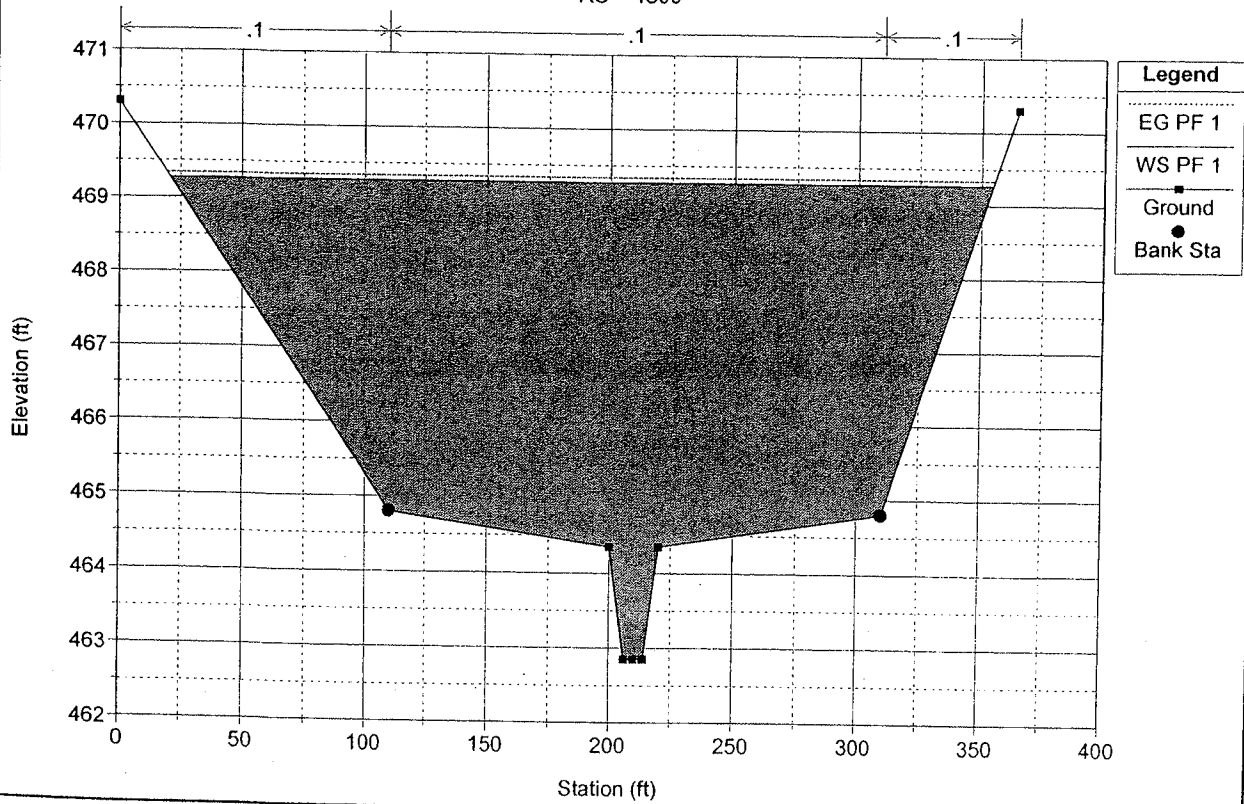

Channel1-3-05 Plan: Plan 01 1/4/2005
RS = 4500

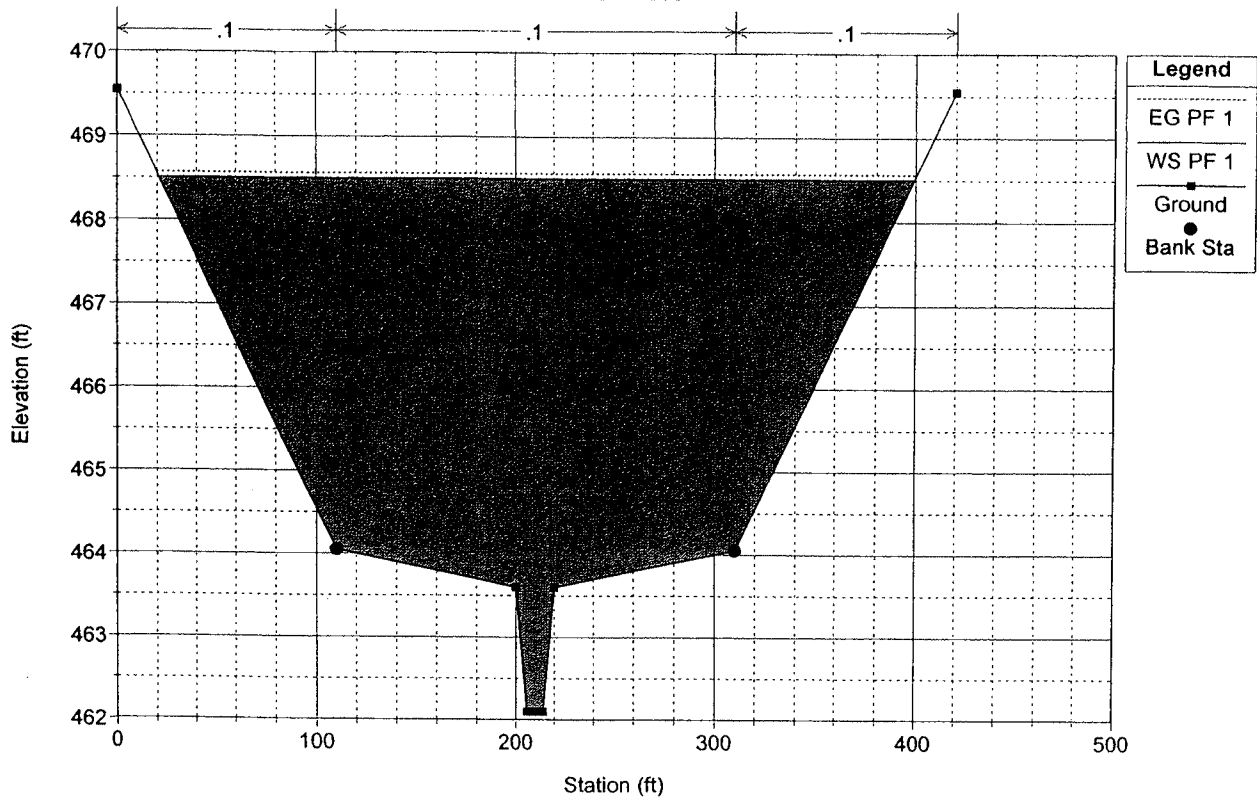

Channel1-3-05 Plan: Plan 01 1/4/2005
RS = 4200

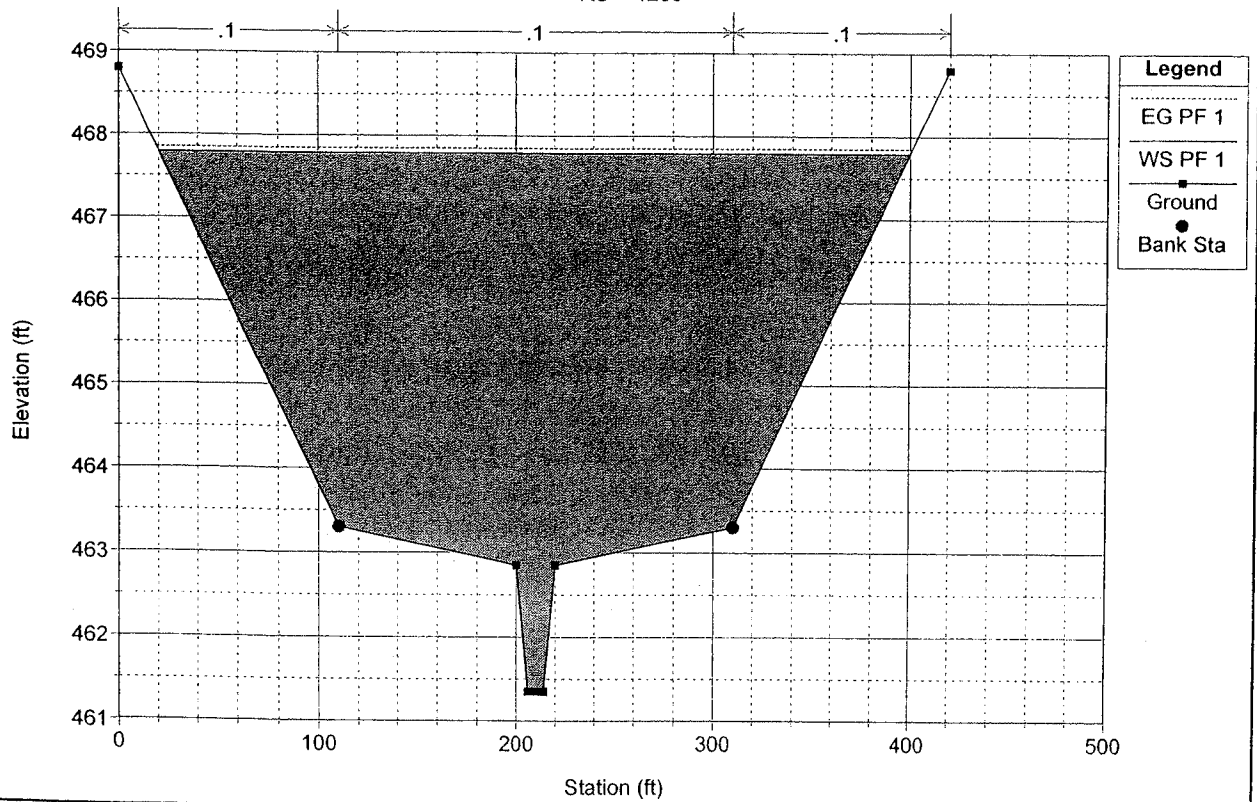

Channel1-3-05 Plan: Plan 01 1/4/2005
RS = 3900

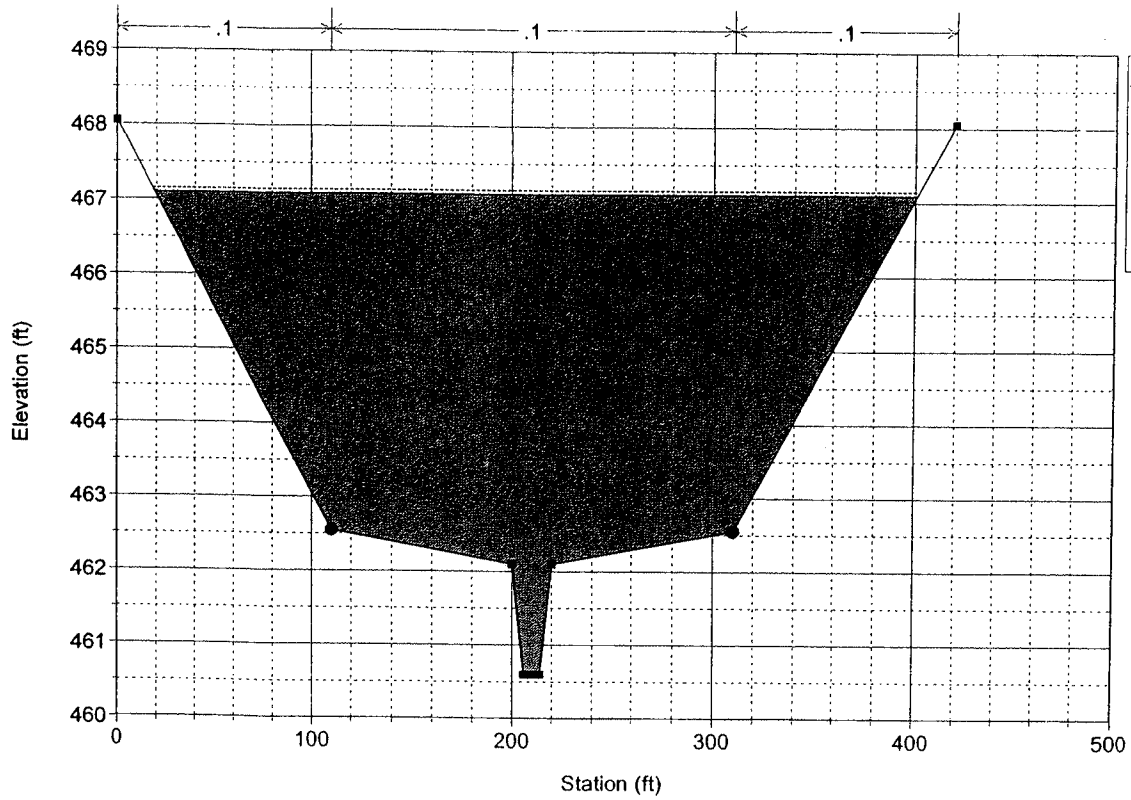

Channel1-3-05 Plan: Plan 01 1/4/2005
RS = 3600

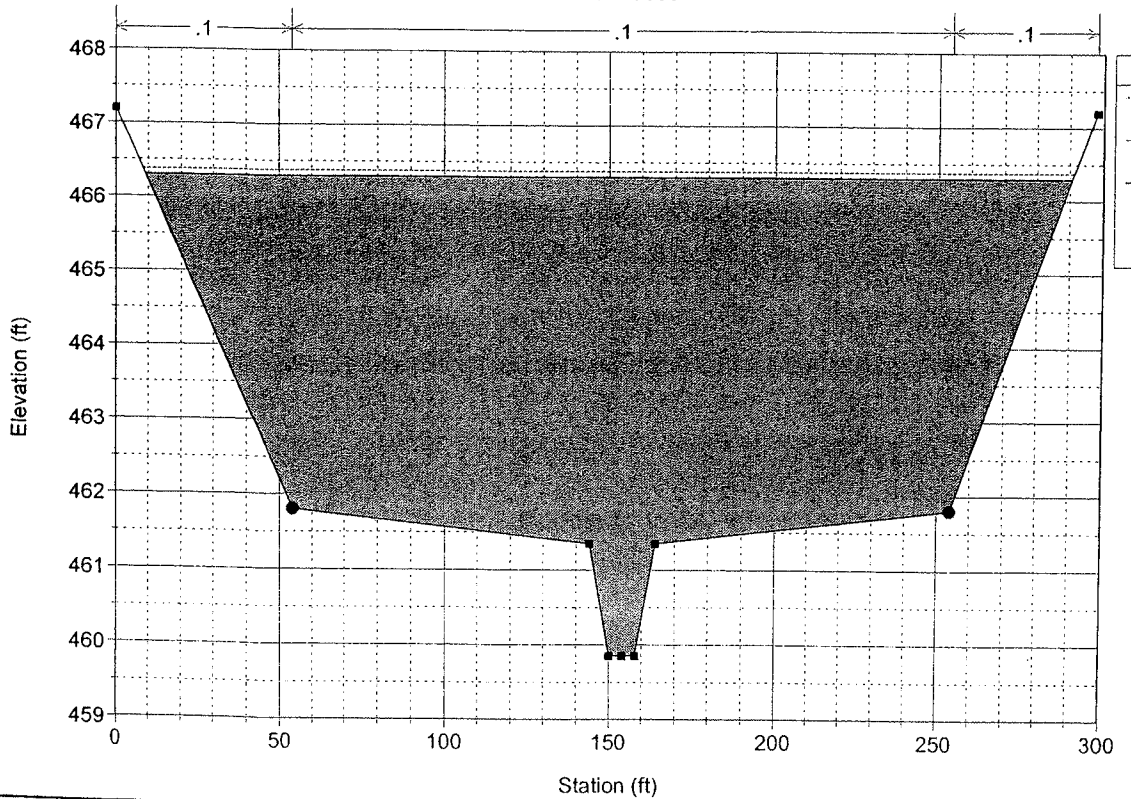

Channel1-3-05 Plan: Plan 01 1/4/2005
RS = 3300

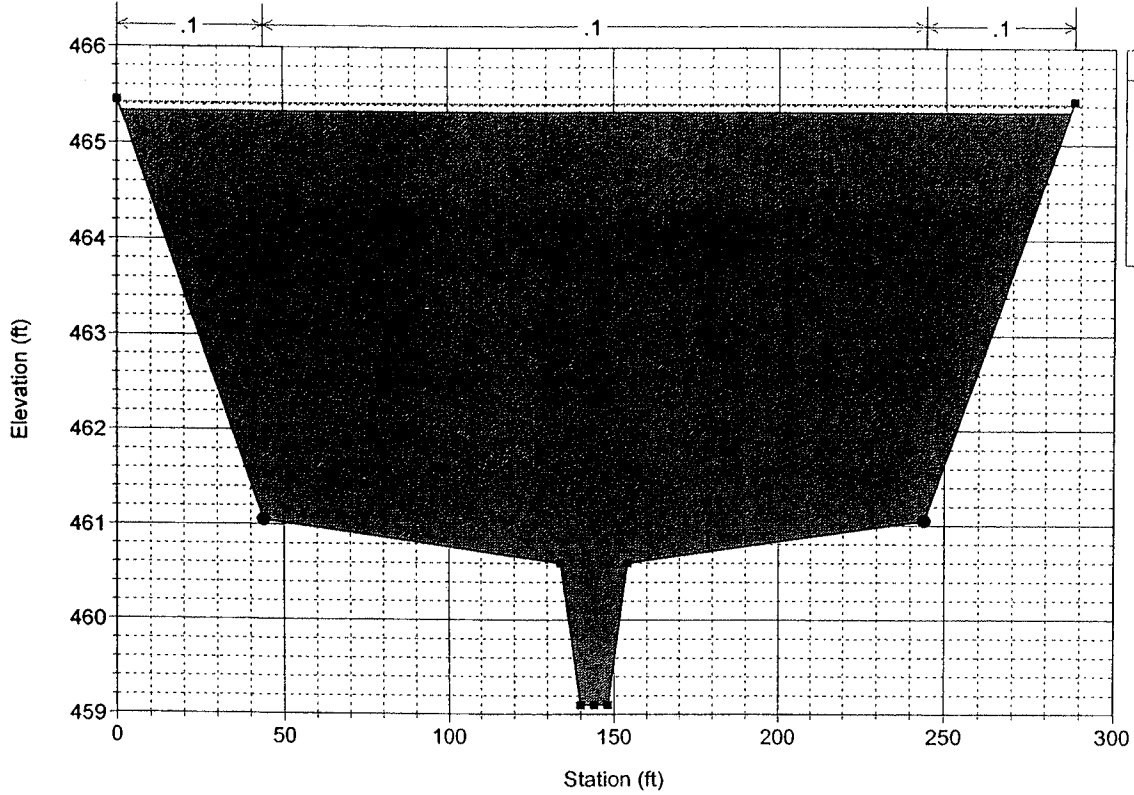

Channel1-3-05 Plan: Plan 01 1/4/2005
RS = 3050

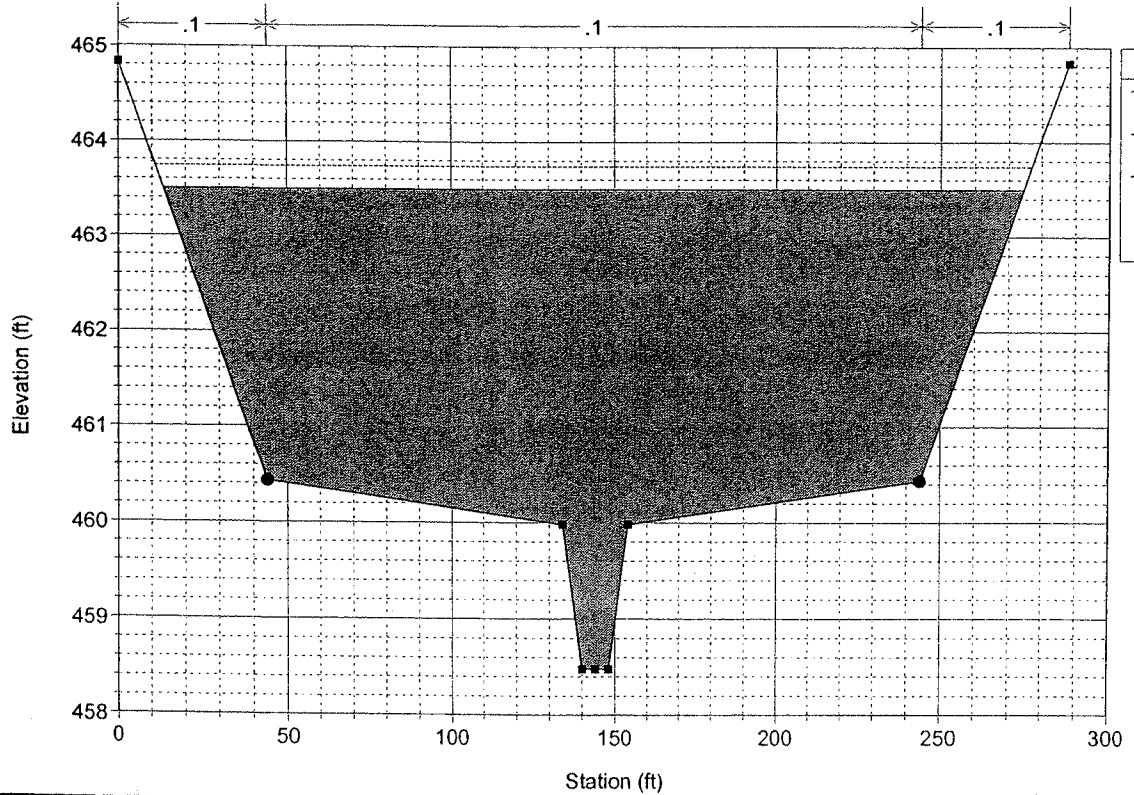

Channel1-3-05 Plan: Plan 01 1/4/2005
RS = 2900

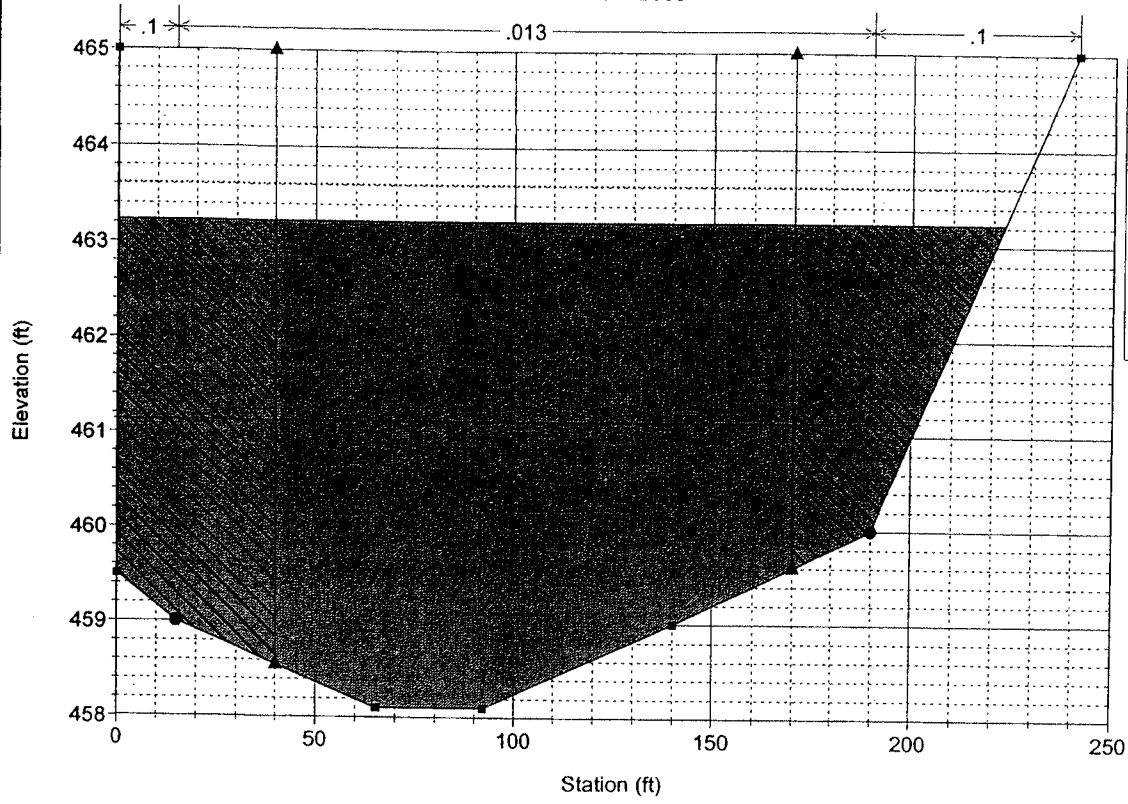

Channel1-3-05 Plan: Plan 01 1/4/2005
RS = 2850

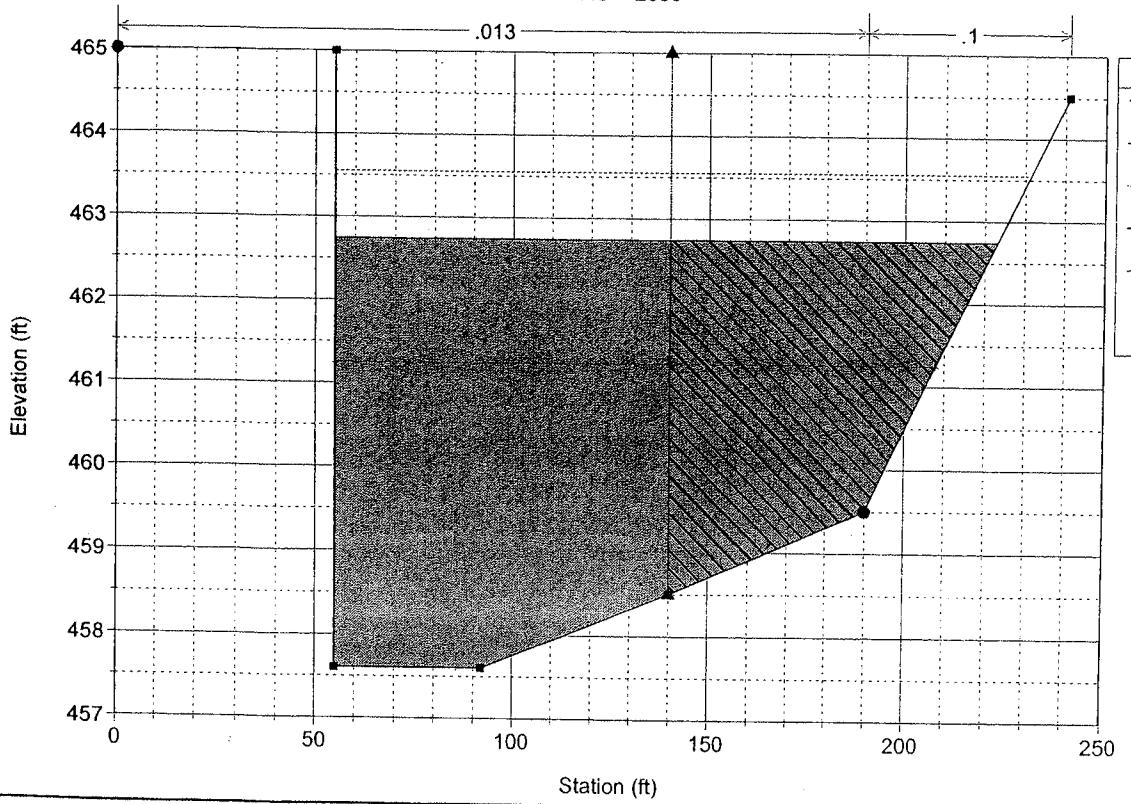

Channel1-3-05 Plan: Plan 01 1/4/2005
RS = 2750 Culv

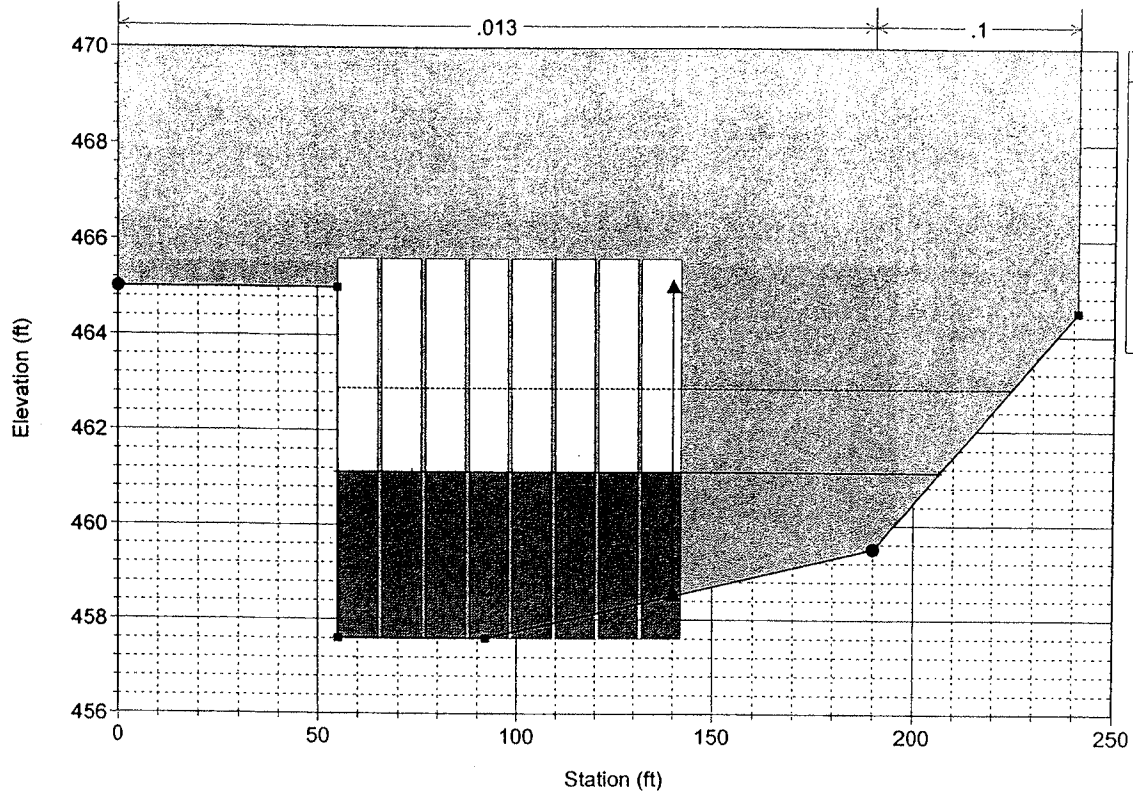

Channel1-3-05 Plan: Plan 01 1/4/2005
RS = 2750 Culv

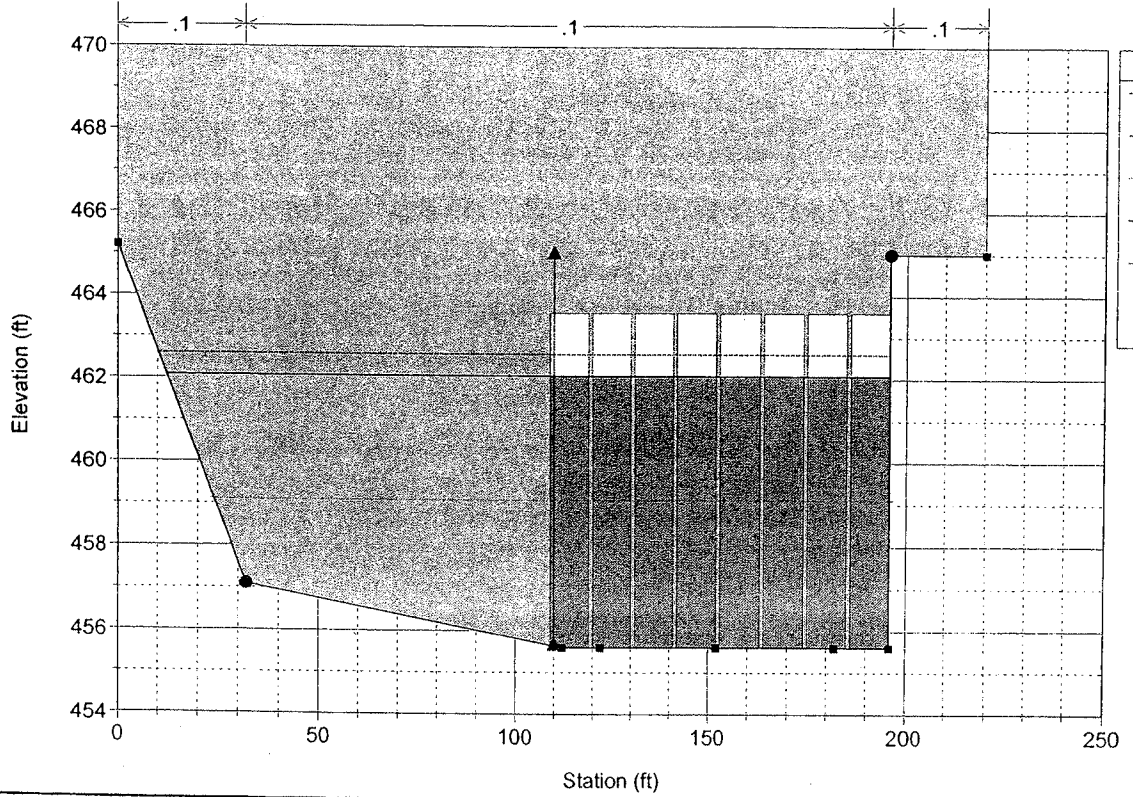

Channel1-3-05 Plan: Plan 01 1/4/2005
RS = 2640

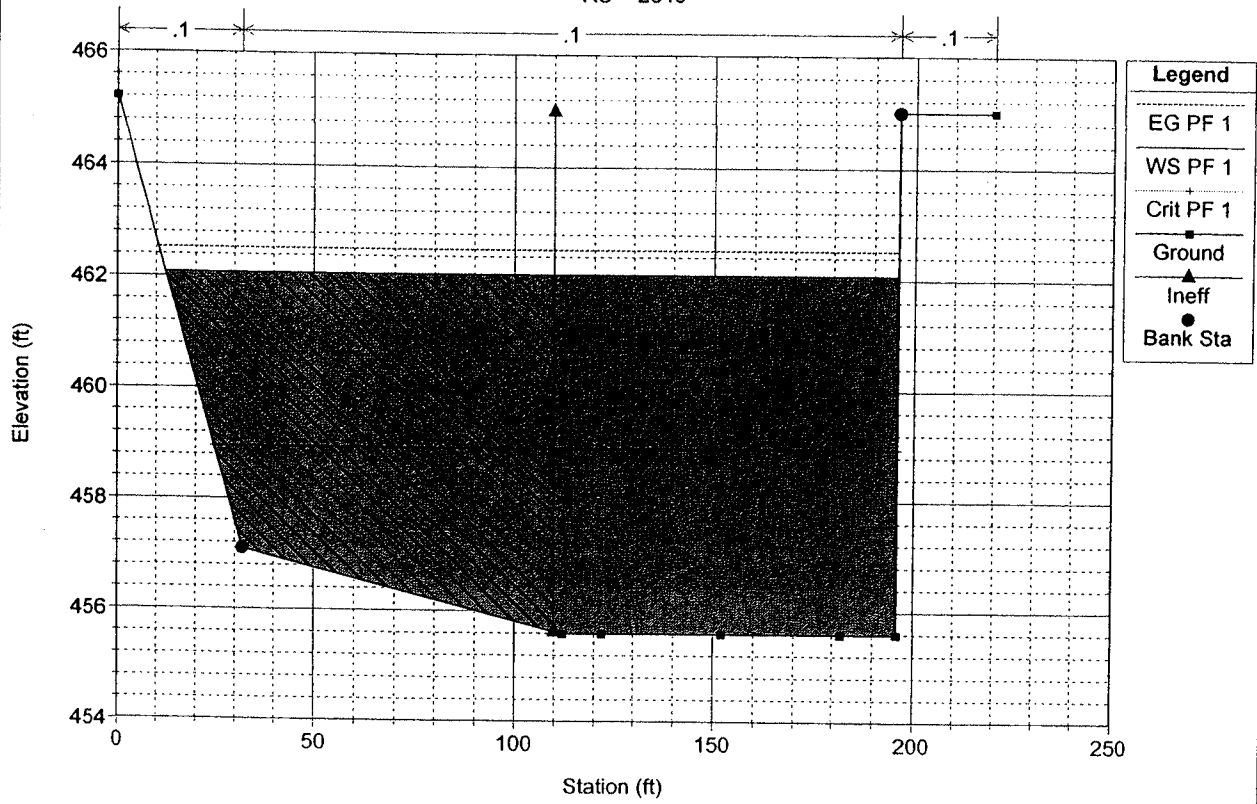

Channel1-3-05 Plan: Plan 01 1/4/2005
RS = 2500

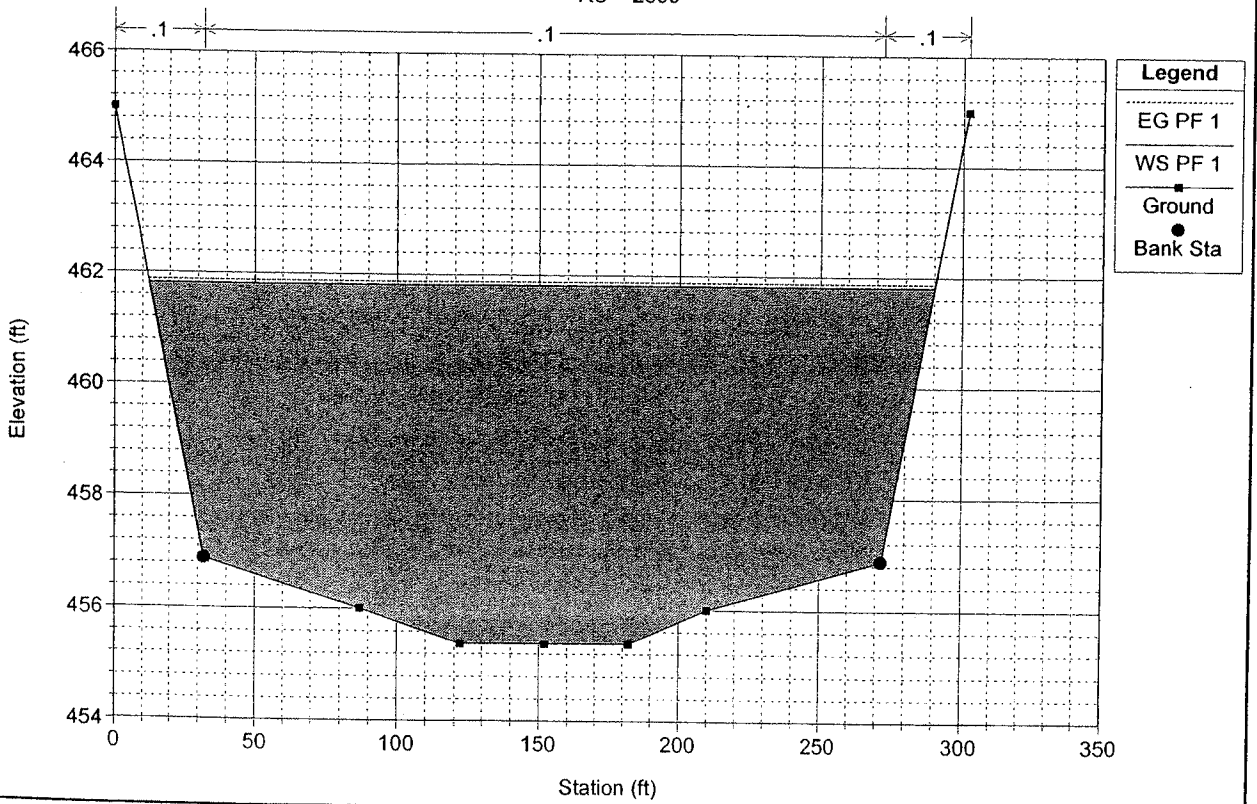

Channel1-3-05 Plan: Plan 01 1/4/2005
RS = 2300

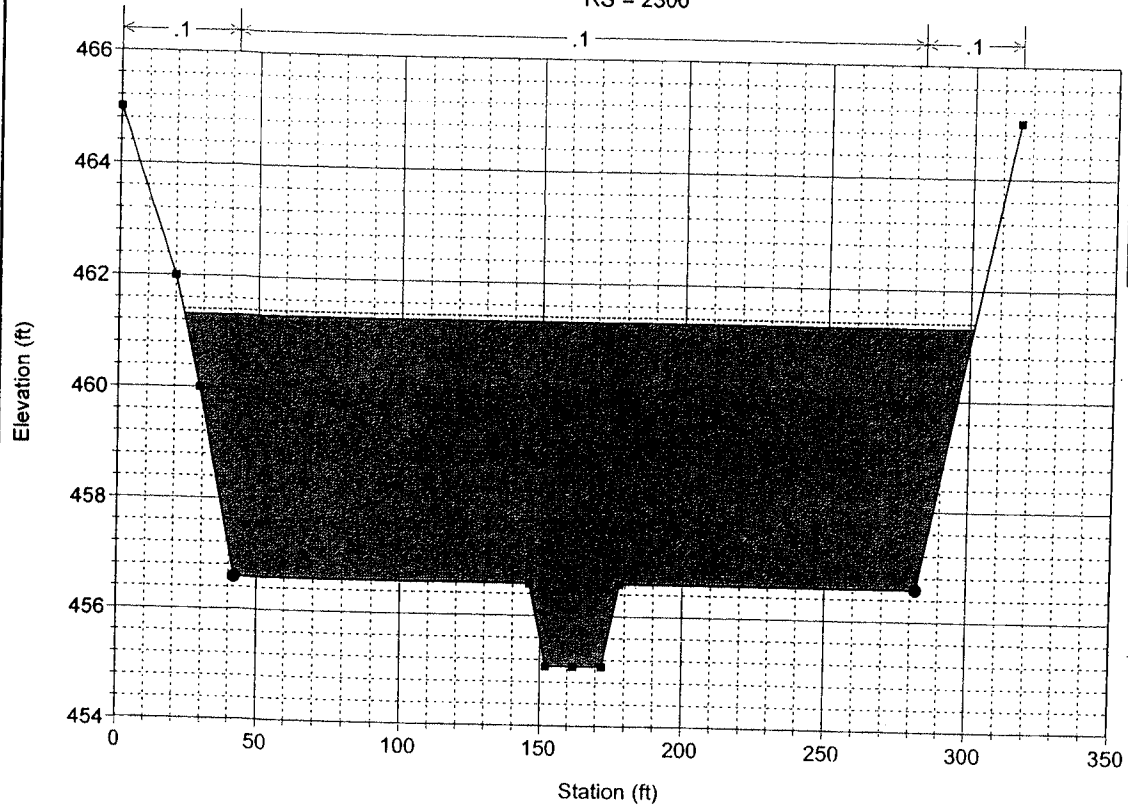

Channel1-3-05 Plan: Plan 01 1/4/2005
RS = 2100

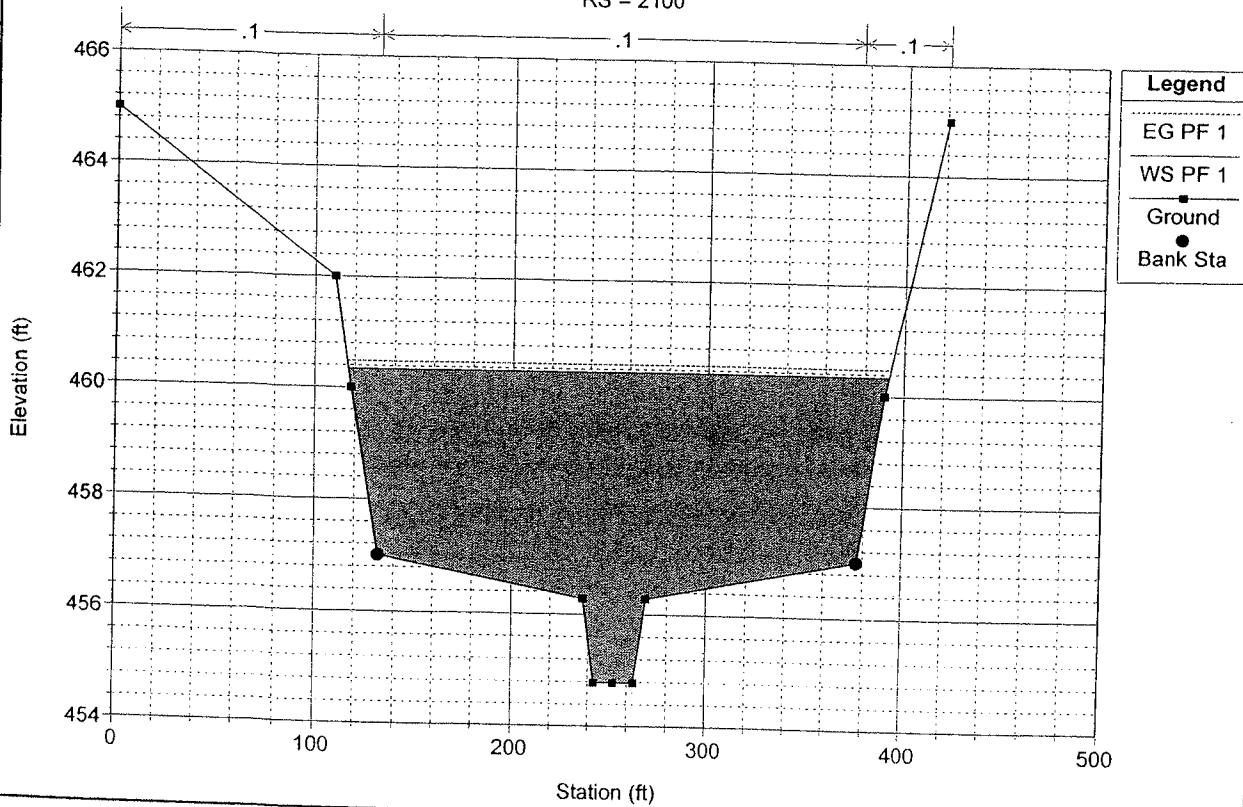

Channel1-3-05 Plan: Plan 01 1/4/2005
RS = 2050

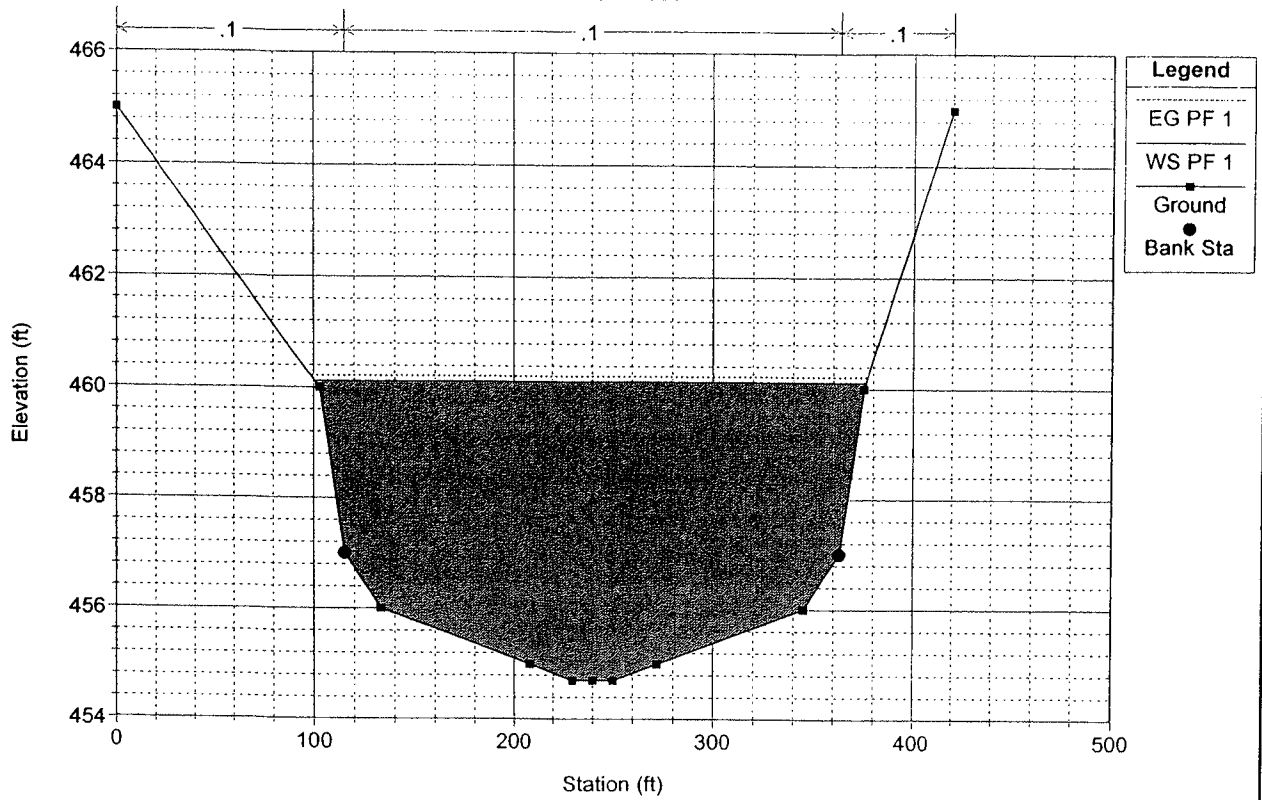

Channel1-3-05 Plan: Plan 01 1/4/2005
RS = 2000 Channel at entrance to detention basin

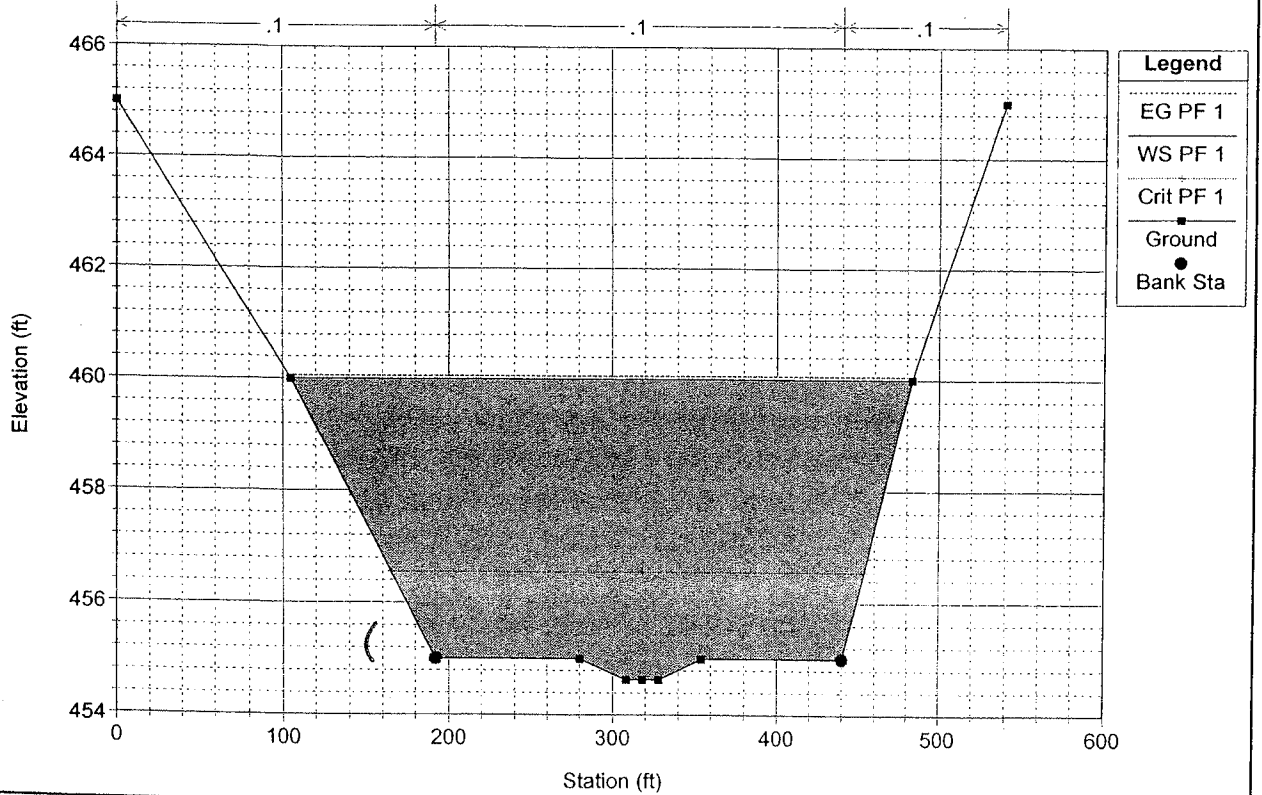

Worksheet

Worksheet for Trapezoidal Channel

Project Description	
Worksheet	Trapezoidal Channel - 1
Flow Element	Trapezoidal Channel
Method	Manning's Formula
Solve For	Discharge

Input Data	
Mannings Coefficient	0.045
Slope	0.006150 ft/ft
Depth	4.00 ft
Left Side Slope	1.50 H : V
Right Side Slope	1.50 H : V
Bottom Width	50.00 ft

Results	
Discharge	1,331.30 cfs
Flow Area	224.0 ft ²
Wetted Perimeter	64.42 ft
Top Width	62.00 ft
Critical Depth	2.73 ft
Critical Slope	0.022466 ft/ft
Velocity	5.94 ft/s
Velocity Head	0.55 ft
Specific Energy	4.55 ft
Froude Number	0.55
Flow Type	Subcritical

Cross Section

Cross Section for Trapezoidal Channel

Project Description	
Worksheet	Trapezoidal Channel - 1
Flow Element	Trapezoidal Channel
Method	Manning's Formula
Solve For	Discharge

Section Data	
Mannings Coefficient	0.045
Slope	0.006150 ft/ft
Depth	4.00 ft
Left Side Slope	1.50 H : V
Right Side Slope	1.50 H : V
Bottom Width	50.00 ft
Discharge	1,331.30 cfs

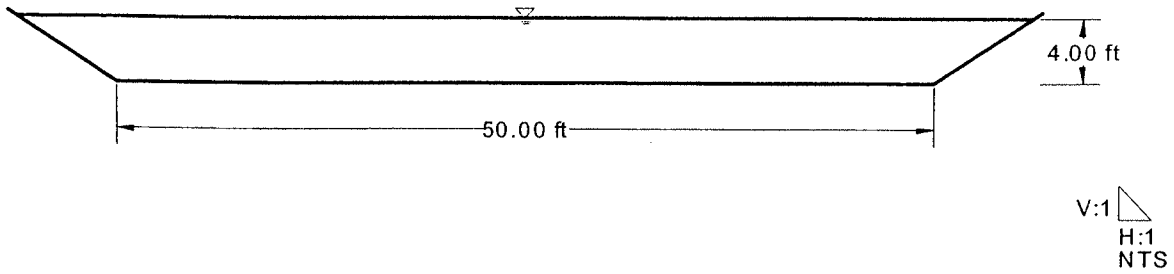

V. PROPOSED DRAINAGE FACILITIES

For most of the Mesa, drainage facilities are constructed as part of development or road projects, and include only facilities in the immediate vicinity of the projects. For the proposed future private development, no designs are available to show these future facilities. Caltrans has prepared plans for their SR-905 project, and those facilities are shown on the attached map.

The only Master Planned facility which needs to be constructed before development takes place is the Main Channel and Detention basin in the East Watershed. Details of this system are presented in Section VI.

VI. PROPOSED DRAINAGE ALTERNATIVES

The historical drainage on the Mesa, with its flat terrain and shallow swales for drainage paths, did not become a problem until development started taking place in the 1960s. This development started concentrating flows in culverts under roads and redefined some of the historical drainage paths. Some of the development solved problems in some areas, but impacted other areas by moving the problem downstream. One of these areas is the existing creek that parallels La Media Road and eventually crosses the border into Mexico. The frequent flooding along portions of this channel is a constraint to future development for some of the areas along the creek.

1. NO PROJECT

The alternative of doing nothing to improve the drainage along the main creek channel would prevent future development from taking place along portions of La Media Road. The existing creek is not deep enough to allow the adjacent properties to drain effectively. To provide continued access along the truck route during storms, if the channel is not constructed, the roads will need to be raised or alternative routes identified. The existing intersection of Airway Road and La Media Road floods after any significant precipitation. The adjacent roads are too low to allow significant flows to pass under them, so they flood frequently. If the roads are raised to allow more flow to pass under them, they will impact the already-developed adjacent property, parts of which would now be lower than the roads, creating even more difficult drainage issues for the properties.

2. CONCRETE CHANNEL

The 1999 Otay Mesa Drainage Study recommended a concrete channel from Otay Mesa Road to the Border Detention Basin. The recommended plan was a concrete channel along the east side of La Media Road until reaching Siempre Viva Road, where it crossed under La Media and followed on the north side of Siempre Viva to box culverts under Siempre Viva that connected to the Border Detention Basin. All of the concrete channel alternatives assumed that the existing creek with its habitat would continue to carry low flows. The 1999 cost for this alternative was \$10.6 million, which would be approximately \$14.9 million in 2005 dollars without land acquisition.

3. LA MEDIA CHANNEL AND BORDER DETENTION BASIN

The largest watershed on the Mesa is the East Watershed, which covers an area at 6.78 square miles (4,340 Acres). All of the flow from this watershed collects at a concentration point at a large culvert where it crosses the border with Mexico and flows under the airport access road and airport runway before flowing into the Tijuana River.

This portion at the Mesa is extremely flat, and the adjacent properties can not effectively drain into the existing small creek channel without raising the elevations of the roads and developments near the creek. To allow for future development and to accommodate runoff from proposed future projects, a new channel is required with inverts from 3 to 5 feet below the existing creek channel.

The proposed channel has a bottom width that varies from 240 feet at the new border detention basin to 200 feet from north of Siempre Viva Road to the Airway Road/La Media Road intersection. The side slopes will vary between 4:1 to 10:1. Heavy riparian vegetation will be allowed to grow in the channel and no annual maintenance will be required. Once the vegetation has matured, maintenance of dead or fallen trees may be required every few years. There will be a 12 foot wide access road on each bank. The Channel will contain the 100 year flood flow with mature vegetation growth.

From the Airway Road/La Media Road intersection, a 35 foot wide concrete channel along the east side of La Media Road will connect with the proposed Caltrans culverts which will be constructed with SR 905. The RCB culverts under the intersection will need to accommodate existing utilities in both roads, which may impact the intersection and the utilities.

The Border Detention Basin will be designed to attenuate peak flows from 5 year to 100 year storms. The outlet structure will be less than six feet high, and will not be under the jurisdiction of the State of California DSOD. The design of the outlet structure will be prepared with final plans for the project. The Detention Basin will be approximately 1700' by 1500' and cover an area of approximately 58 acres.

Border Detention Basin

Area:	58 Acres
Max. Water Depth:	6.0 Feet
Max. Storage Volume:	308 AF

The basin will be graded to appear natural. Natural vegetation will be allowed to grow in the basin and no annual maintenance will be required. A low-flow stream will be created through the basin. A Maintenance Assessment District may be created for maintaining the channel and detention basin.

The basin and channel will require the removal of approximately 915,000 CY of soil. It is assumed that this export will be used on adjacent properties to raise the building pad grades thereby limiting the haul distance. A preliminary cost estimate was prepared which reflects both the construction costs and the land acquisition costs. A Property Ownership Map which shows the ownership within the East Watershed is attached.

La Media Channel and Border Detention Basin

Preliminary Opinion of Probable Construction Cost

2/8/2005

Kimley-Horn and Associates

Construction Items

Item No.	Description	Quantity	Units	Unit Price	Cost
1	Excavation	822,500	CY	\$2	\$1,645,000
2	Airway Road culvert (6~5'wx5'h)	300	CY	\$1,500	\$450,000
3	La Media/Airway Road intersection culvert (6~10'wx6'h)	1,500	CY	\$1,500	\$2,250,000
4	Siempre Viva Road culvert (8~10'wx8'h)	1,490	CY	\$1,500	\$2,235,000
5	Detention Basin Outlet Structure	1	LS	\$100,000	\$100,000
6	Traffic Control	1	LS	\$100,000	\$100,000
7	Utility Relocation	1	LS	\$150,000	\$150,000
8	Street Repair	1	LS	\$50,000	\$50,000
9	Erosion Control	1	LS	\$50,000	\$50,000
10	Revegetation	1	LS	\$600,000	\$600,000
		Subtotal			\$7,630,000
		Contingency		20%	\$1,526,000
		Total			\$9,156,000

Land Acquisition

1	Land Acquisition (outside MHPA)*	2,610,000	SF	\$4	\$10,440,000
2	Land Acquisition (inside MHPA)**	1,820,000	SF	\$1	\$1,820,000
		Subtotal			\$12,260,000
		Contingency		20%	\$2,452,000
		Total			\$14,712,000

Total Cost (Construction and Land Acquisition)

\$23,868,000

- Notes: * Includes area of detention basin and channel south of Siempre Viva
 ** Includes entire area within MHPA boundary
 *** Estimate does not include engineering, environmental, geotechnical, surveying, etc.

VII. RECOMMENDED DRAINAGE DESIGN CRITERIA

Since the five watershed areas on the Mesa flow in every direction except east, they flow into different watersheds with different constraints and impacts. The runoff from the five watersheds will have different criteria for design of drainage facilities.

West Perimeter Watershed

This watershed consists of smaller Mesa-top watersheds with a total area of approximately 254 acres that drain to the west to three separate creeks in canyons and gullies. These creeks are carried under the SD&AE and Trolley tracks and through San Ysidro in buried storm drain systems. The storm drains under the tracks have hydraulic capacities of 30 cfs (18" RCP) and 125 cfs (36" RCP) based on the San Ysidro Boulevard Area Master Drainage plan prepared by BSI Consultants, February 15, 1996. Sub-basins OT3-7 and OT3-8 combine downstream into a single creek that flows to the 36" RCP. The current study estimates 140 cfs (Q100) will flow off of the Mesa into this sub-basin. This study does not address the capacity of the downstream system or include the hydrologic analysis for areas to the west of the Mesa, but clearly the 125 cfs capacity of the existing system will be exceeded. This area will need to be addressed in more detail during design of the upstream tributary development. Detention Basins are recommended which will reduce peak flows in the sub-basin to minimize impacts on the downstream system. These detention basins will reduce the peak, 50-year, and 100-year flow to predevelopment levels. Because of the unstable soils in this area, care should be taken that the proposed detention basins and relocated drainage facilities do not contribute to an increase in the risk of slides through increased saturation of the soil.

West Watershed

The West Watershed consists of smaller Mesa-top watersheds that drain into the tributary canyons of Spring Canyon. All of the flow from the watershed flows into Mexico at the Spring Canyon concentration point. Detention basins will be required to reduce the post-development peak flows to predevelopment levels for the 50-year and 100-year storm. If the detention basins concentrate flows at the upper edge of canyons, care must be taken to ensure that erosion potential is not increased downstream.

East Watershed

The East Watershed flows to Mexico at a single concentration point between Britannia and La Media roads. Requirements for the control of peak runoff from development in this watershed already exist. The "Notice" dated August 7, 1987 (page 2), sets criteria for detention basins and for storm drain sizing. As part of the future storm drain project in this watershed, a single detention basin will be constructed at the border. The construction of this basin will eliminate the need for individual on-site detention basins for subsequent development.

North Perimeter Watershed

These small watersheds along the northern edge of the Mesa flow into small canyons that flow into the Otay River. There are no peak flow attenuation requirements for flows from these watersheds. There may be water quality issues with the Otay River, and there may be erosion issues from storm drains on the Mesa. Only approximately 14 acres of Neighborhood 6 are in this watershed.

VIII. STORM WATER QUALITY REQUIREMENTS

Because of problems related to the poor water quality of storm water runoff from urban conveyance systems, the City requires that storm water Best Management Practices (BMPs) be constructed for all new projects. The storm water discharge contains pollution such as chemicals, trash, sediment, bacteria, metals, oil and grease. Construction projects which add impervious areas and change drainage patterns increase the discharge of these pollutants.

The Municipal Storm Water National Pollutant Discharge Elimination System Permit (NPDES Municipal Permit), approved February 21, 2001 by the San Diego Regional Water Quality Control Board (RWQCB), requires the City to implement regulations for constructing storm water BMPs for development projects.

In 2003, as part of the San Diego Municipal Code, the City published “Storm Water Standards – A Manual for Construction & Permanent Storm Water Best Management Practices Requirements.” This manual is the reference document for all of the storm water issues encountered in development, including BMPs. Included in this report are Appendix C – Example Permanent Storm Water Best Management Practices, and the Storm Water Requirements Applicability Checklist from the City’s Manual. Before preparing a drainage study, the “Storm Water Requirements Applicability Checklist” is completed. This checklist is used to determine the priority level of the project. Most of the projects on the Mesa will require Priority Project Permanent Storm Water BMPs and High Priority Construction Storm Water BMPs.

All projects subject to the priority permanent BMP requirements must include a “Water Quality Technical Report.” From the manual, the report will include:

1. A drainage study report prepared by a civil engineer, hydrologist, or hydrogeologist registered in the State of California, with experience in the science of stream and river generated surface features (i.e., fluvial geomorphology) and water resources management, satisfactory to the City Engineer. The report shall consider the project area’s location (from the larger watershed perspective), topography, soil and vegetation conditions, percent impervious area, natural and infrastructure drainage features, and any other relevant hydrologic and environmental factors to be protected specific to the project area’s watershed.
2. A field reconnaissance to observe and report on downstream conditions, including undercutting erosion, slope stability, vegetative stress (due to flooding, erosion, water quality degradation, or loss of water supplies) and the area’s susceptibility to erosion or habitat alteration as a result of any future upstream development.
3. A hydrologic analysis to include rainfall runoff characteristics from the project area including at a minimum, peak runoff, time of concentration, and detention volume (if appropriate). These characteristics shall be developed for the two-year and ten-year frequency, six-hour or 24-hour, type B storm for the coastal areas of San Diego County. The largest peak flow should be included in the report. The report shall also report the project’s conditions of concern based on the hydrologic and downstream conditions discussed above. Where downstream conditions of concern have been identified, the drainage study shall establish that pre-project hydrologic conditions that minimize impacts on those downstream conditions of concern would be either improved or maintained by the proposed project, satisfactory to the City Engineer, by incorporating the permanent BMP requirements.

Appendix D of the Manual includes detailed guidelines for the Water Quality Technical Report.

There are numerous alternative permanent BMPs that can be used for each project. The alternatives include Site Design BMPs, Source Control BMPs, and Treatment Control BMPs. The Site Design BMPs are primary ways to reduce storm water runoff through means such as increased pervious areas, increased infiltration, use of natural channels, and appropriate landscaping. All of these except dry wells are applicable to the Mesa. Source Control BMPs are meant to control pollutants at their source before they enter storm water, and are all applicable to the Mesa. Treatment Control BMPs treat the storm water before it leaves the property, and include natural methods such as biofilters, detention basins, wetlands, and porous pavement, and mechanical methods such as filters and separators. The one Treatment Control BMP that is not applicable to the Mesa is infiltration, which is not very effective on the Mesa because of the clay soils.

Most of Otay Mesa drains to the south across the border with Mexico and eventually into the Tijuana River. A small portion flows north into the Otay River, and the far western part of the Mesa flows to the west through San Ysidro and then into the Tijuana River. The Tijuana River has been identified by the 2002 Clean Water Act as a "Section 303(d) Water Quality Limited" river. The pollutants of concern which are included in the attached pages from the USEPA, need to be listed, and the new development project's potential impacts on these pollutants need to be included in the project's drainage report.

Recommended Storm Water Policies

- 1. Apply water quality protection measures to land development projects during project design, permitting, construction, and operations in order to minimize the quantity of runoff generated on-site, the disruption of natural water flows and the contamination of storm water runoff.**
 - a. Increase on-site infiltration, and preserve, restore or incorporate natural drainage systems into site design
 - b. Reduce the amount of impervious surfaces through selection of materials, site planning, and narrowing street widths where possible.
 - c. Increase the use of natural vegetation and landscaping in drainage design.
 - d. Avoid conversion of areas particularly susceptible to erosion and sediment loss (e.g.: steep slopes), and where unavoidable, enforce regulations that minimize these impacts.
 - e. Avoid land use, site development, and zoning regulations that limit impacts on, and protect the natural integrity of topography, drainage systems, and water bodies.
 - f. Maintain landscape design standards that minimize the use of pesticides and herbicides.
 - g. Enforce maintenance requirements in development permit conditions.

- 2. Require construction contractors to comply with accepted storm water pollution prevention planning practices for all projects.**
 - a. Minimize the amount of graded land surface exposed to erosion and enforce control ordinances
 - b. Continue routine inspection practices to check for proper erosion control methods and housekeeping practices during construction.
 - c. Ensure that contractors are aware of and implement urban runoff control programs.

- 3. Encourage measures to promote the proper collection and disposal of pollutants at the source, rather than allowing them to enter the storm drain system.**
 - a. Promote the provision of used oil recycling and/or hazardous waste recycling facilities and drop-off locations.
 - b. Follow up on complaints of illegal discharges and accidental spills to storm drains, waterways, and canyons.



REFERENCES

This Water Quality Technical Report incorporates, by reference, the appropriate elements of the following documents and plans required by local; State or Federal agencies.

1. Municipal Storm Water National Pollutant Discharge Elimination System (NPDES) Permit
2. City of San Diego Storm Water Standards
3. Drainage Study for the Otay Mesa Community Plan
4. California Stormwater BMP Handbook, "Extended Detention Basin – TC-22" New Development and Redevelopment, January 2003
5. California Stormwater BMP Handbook, "Vegetated Swale – TC-30" New Development and Redevelopment, January 2003