

*City of San Diego
Land Guidance System*

*Transit-Oriented Development
Design Guidelines*

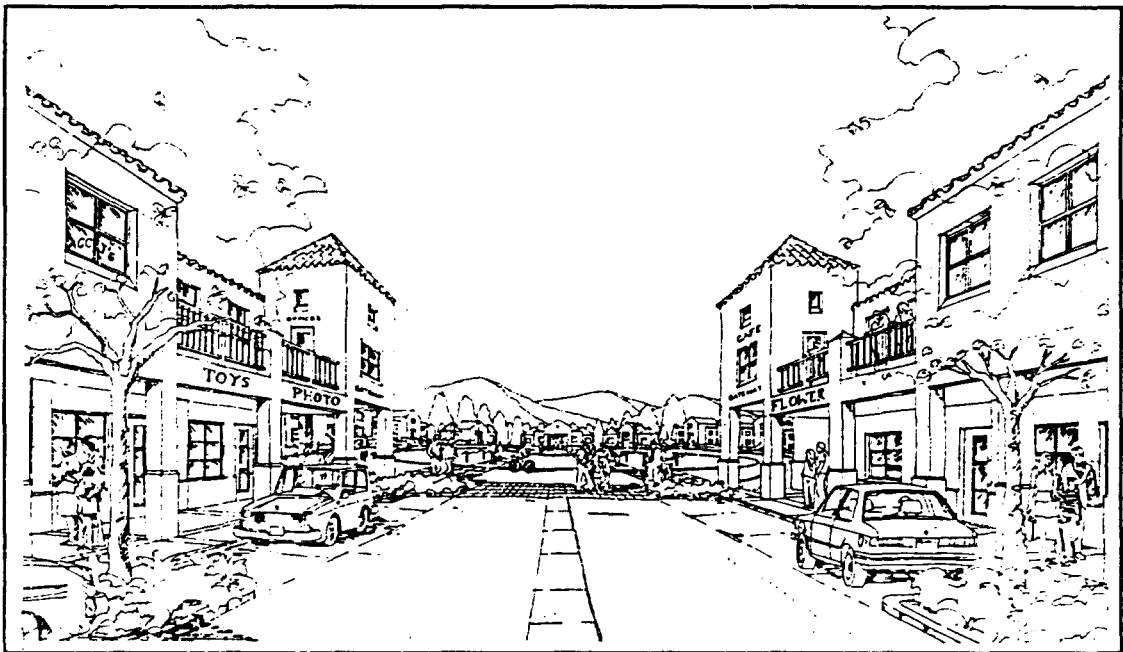

*Prepared by
Calthorpe Associates*

*for the
City of San Diego*

Approved by the City Council August 4, 1992



MAYOR

Maureen O'Connor

COUNCIL

District 1 Abbe Wolfsheimer

District 2 Ron Roberts

District 3 John Hartley

District 4 George Stevens

District 5 Tom Behr

District 6 Valerie Stallings

District 7 Judy McCarty

District 8 Bob Filner

CITY ATTORNEY

John M. Witt

CITY MANAGER

Jack McGrory

PLANNING COMMISSION

Karl ZoBell, Chariman

Ralph Pesqueira

Edward Reynolds

Scott Bernet

Lynn Benn

Chris Calkins

Verna Quinn

ENGINEERING & DEVELOPMENT DEPARTMENT

M. Victor Rollinger, Director

William Schempers, Jr., Assistant Director

CITY PLANNING DEPARTMENT

Severo Esquivel, Acting Director

George Arimes, Assistant Director

Michael J. Stepner, City Architect

Linda Johnson, Principal Planner

Nancy Schwarz, Project Planner

LAND GUIDANCE SUBCOMMITTEE

Stephen H. Silverman, Chair

Tess Nelson, Vice-Chair

Approved by The City Council August 4, 1992

Resolution No. R-280480



THE CITY OF

SAN DIEGO

525 "B" STREET • SUITE 2002 • SAN DIEGO, CALIFORNIA 92101 - 4411

PLANNING
DEPARTMENT
OFFICE OF THE
CITY ARCHITECT
533-4500

October, 1992

A Transit-Oriented Development (TOD) is a compact land use pattern with housing, public parks and plazas, jobs, and services located along key points on the transit system. The strategic application of the TOD principles will greatly help us in our efforts as a community to reduce automobile dependence, improve air quality, and create pedestrian-oriented, interactive neighborhoods.

The guidelines are the result of an eighteen month long effort under the City's Land Guidance Program. In addition to the work of Calthorpe Associates, key players included the Land Guidance Subcommittee (a broad-based Citizens Advisory Committee), City staff, and other public agency staff. The TOD Guidelines and a companion City Council Policy (600-39) were approved by the City Council on August 4, 1992.

Now that the guidelines are approved, they are being incorporated into basic City policies and regulations. The TOD perspective is being brought to the Street Design Manual update, the Zoning Code update, the Progress Guide and General Plan, community plan updates, demonstration projects, and the Regional Growth Management Strategy.

The TOD concept provides the community with an approach to create a desirable and more efficient urban form while addressing the issues of traffic congestion, air quality, neighborhood character, and growth management. The guidelines support the substantial public investment in transit systems and result in regional, environmental, and fiscal benefits over the long term.

I hope that you find these guidelines to be interesting and useful.

Michael J. Stepner, FAIA, AICP
City Architect

Table of Contents

<i>Introduction</i>	1
<i>Land Guidance System</i>	1
<i>Transit-Oriented Development Concept</i>	1
<i>Transit-Oriented Developments Defined</i>	4
<i>How To Use These Guidelines</i>	6
<i>Design Guidelines</i>	7
<i>1. Definitions and Guiding Principles</i>	7
Guideline 1A: TRANSIT-ORIENTED DEVELOPMENT (TOD)	7
Guideline 1B: RELATIONSHIP TO TRANSIT AND CIRCULATION	8
Guideline 1C: URBAN TOD	10
Guideline 1D: NEIGHBORHOOD TOD	11
Guideline 1E: REVITALIZING, URBANIZING AND NEW GROWTH AREAS	12
Guideline 1F: CORE COMMERCIAL AREA	14
Guideline 1G: TOD RESIDENTIAL AREAS	15
Guideline 1H: PUBLIC USES	16
Guideline 1I: MIXED-USE	17
Guideline 1J: STREET AND CIRCULATION SYSTEM	18
Guideline 1K: GENERAL DESIGN CRITERIA	19
Guideline 1L: SECONDARY AREAS	20
Guideline 1M: OTHER USES	21
Guideline 1N: COORDINATED PLANNING	22
Guideline 1O: PHASING	23
<i>2. TODs on Redevelopable and Urbanizing Sites</i>	24
Guideline 2A: LOCATION AND PROXIMITY TO TRANSIT SERVICE	24
Guideline 2B: SITE BOUNDARY DEFINITION	25
Guideline 2C: INTEGRATION OF EXISTING ON-SITE USES	27
Guideline 2D: MIX OF USES	29
Guideline 2E: RETROFIT OF EXISTING STREETS FOR PEDESTRIAN, BICYCLE & AUTO CONNECTIONS	30
Guideline 2F: PROXIMITY OF COMPETING RETAIL	31

3. TODs in New Growth Areas	32
Guideline 3A: LOCATION AND PROXIMITY TO TRANSIT SERVICE	32
Guideline 3B: SITE BOUNDARY DEFINITION	33
Guideline 3C: SITE SIZE AND PHYSICAL CHARACTERISTICS	34
Guideline 3D: DISTRIBUTION OF TODS	34
Guideline 3E: MIX OF USES	35
4. Core Commercial Areas	36
Guideline 4A: CORE COMMERCIAL AREAS	36
Guideline 4B: OFFICE INTENSITIES	38
Guideline 4C: CORE COMMERCIAL CONFIGURATION	39
Guideline 4D: COMMERCIAL BUILDING SETBACKS	40
Guideline 4E: COMMERCIAL BUILDING FACADES	41
Guideline 4F: COMMERCIAL BUILDING ENTRIES	42
Guideline 4G: UPPER STORY USES IN CORE COMMERCIAL AREAS	43
5. TOD Residential Areas	44
Guideline 5A: RESIDENTIAL MIX	44
Guideline 5B: RESIDENTIAL DENSITIES	45
Guideline 5C: ANCILLARY UNITS	46
Guideline 5D: RESIDENTIAL BUILDING SETBACKS	47
Guideline 5E: RESIDENTIAL BUILDING FACADES	48
Guideline 5F: RESIDENTIAL BUILDING ENTRIES	48
Guideline 5G: RESIDENTIAL GARAGES	49
6. Secondary Areas	50
Guideline 6A: TYPE AND PROXIMITY OF USES	50
Guideline 6B: RESIDENTIAL DENSITIES IN SECONDARY AREAS	51
Guideline 6C: BIKEWAYS IN SECONDARY AREAS	51
Guideline 6D: PUBLIC AMENITIES IN SECONDARY AREAS	52
7. Open Space, Parks, and Public Uses	53
Guideline 7A: LOCATION OF PARKS AND PLAZAS	53
Guideline 7B: PARK AND PLAZA DESIGN	54
Guideline 7C: PARK AND PLAZA LANDSCAPING	55
Guideline 7D: OPEN SPACE RESOURCE PROTECTION	56
Guideline 7E: COMMUNITY BUILDINGS	57
Guideline 7F: SCHOOLS AND COMMUNITY PARKS	58
Guideline 7G: DAYCARE	59

8. Street and Circulation System	60
Guideline 8A: ARTERIAL STREETS AND THOROUGHFARES	60
Guideline 8B: STREET DIMENSIONS	61
Guideline 8C: CONNECTOR STREETS	62
Guideline 8D: COMMERCIAL STREETS	63
Guideline 8E: LOCAL STREETS	63
Guideline 8F: ALLEYS	64
Guideline 8G: STREET VISTAS	65
Guideline 8H: STREET TREES	66
Guideline 8I: ON-STREET PARKING	67
Guideline 8J: INTERSECTION DESIGN	68
9. Pedestrian and Bicycle System	69
Guideline 9A: PEDESTRIAN ROUTES	69
Guideline 9B: CONNECTIONS TO THE CORE AREA AND THE TRANSIT STOP	70
Guideline 9C: ARTERIAL CROSSINGS AND PEDESTRIAN BRIDGES	71
Guideline 9D: SIDEWALKS	72
Guideline 9E: BIKEWAYS	73
Guideline 9F: BIKE PARKING	74
10. Transit Stops	75
Guideline 10A: SITE RELATIONSHIP TO TRANSIT STOP	75
Guideline 10B: TRANSIT STOP FACILITIES	76
Guideline 10C: STREET CROSSINGS TO TRANSIT STOPS	77
Guideline 10D: PARK AND RIDE LOTS	78
11. Parking Requirements and Configuration	79
Guideline 11A: PARKING STANDARDS	79
Guideline 11B: JOINT USE PARKING	81
Guideline 11C: PARKING CONFIGURATION	82
Guideline 11D: ON-STREET PARKING REQUIREMENTS	83
Guideline 11E: PARKING MITIGATION MEASURES	83
Guideline 11F: SIZE OF SURFACE PARKING LOTS	84
Guideline 11G: SURFACE PARKING REDEVELOPMENT	85
Guideline 11H: RETAIL IN STRUCTURED PARKING LOTS	86
Guideline 11I: PARKING LOT LANDSCAPING	86
<i>Incentives and Implementation Strategies</i>	87
<i>Long-Range Planning</i>	87
<i>Environmental Review and Permit Processing</i>	88
<i>Zoning and City Standards</i>	89
<i>Public Services and Infrastructure</i>	90

Introduction

Land Guidance System

The Land Guidance Section was established in September 1989 as a part of the City of San Diego's Mobility Program. The aim of the Land Guidance Section is to reduce transportation demand through new and revised land development policies. Since its inception, the Section has undertaken a number of studies characterizing the status of traffic congestion and land development patterns in the city. The group has also assessed the effectiveness of adopted policies and standards as to whether they support or hinder transportation demand management goals.

In May 1991, the Planning Department and the Engineering and Development Department contracted with Calthorpe Associates to prepare Design Guidelines, Incentives and Implementation Strategies aimed at redirecting urban growth to patterns which encourage non-automobile travel, yet protect the city's quality of life. This package, along with a number of accompanying policies and programs, constitutes the Land Guidance System for the City of San Diego.

Transit-Oriented Development Concept

Guiding Principles

San Diego, along with a number of other growing metropolitan regions throughout the country, is increasingly faced with a crisis of many dimensions: mounting traffic congestion, diminishing affordable housing, receding open space, threatened wildlife, urban sprawl, air pollution and socially isolated communities. Reliance upon typical patterns of low density urban development will perpetuate these problems. The goal of the Land Guidance System is to establish policies and standards which seek to address these problems by redirecting urban growth to patterns which reduce automobile dependence and support alternative modes of transportation, while minimizing impacts on existing community character. The Design Guidelines for Transit Oriented Development (TODs) represent strategies to accommodate projected growth within San Diego, maintain the city's present quality of life, and allow for continued economic vitality. Consistent with these concerns, these Design Guidelines are based on the following guiding principles:

- Maximize the use of existing urbanized areas accessible to transit through infrastructure-sensitive infill and redevelopment.
- Reduce consumption of non-urban areas by designing the urban area efficiently.
- Employ land use strategies to reinforce transit.
- Reduce the number of auto trips and regional vehicle miles traveled by creating opportunities to walk and bike.
- Protect the natural environment and community character by reducing the need for roadway expansions.
- Reduce air pollutant emissions and conserve limited energy resources.
- Provide a diversity of housing types.
- Foster a more vital, interactive and secure community.

TODs link transit and land use

The Transit-Oriented Development (TOD) concept is simple: moderate and high density housing, along with complementing public uses, jobs, retail and services, are concentrated in mixed-use developments located at strategic points along the regional transit system. Low density housing and other auto-oriented uses surround these TODs in "Secondary Areas." The location, design, configuration, and mix of uses in a TOD provides an alternative to traditional development by emphasizing a pedestrian-oriented environment and reinforcing the use of public transportation.

This linkage between land use and transit is designed to result in an efficient pattern of development that supports the transit system and makes significant progress in reducing sprawl, traffic congestion, and air pollution. The TOD's mixed-use clustering of land uses within a pedestrian-friendly area connected to transit, provides for growth with minimum environmental and social costs.

TODs aren't just a transit strategy; a walkable environment is key to reducing congestion

TODs represent a land use strategy which seeks to strike a balance between resolving today's critical transportation issues and allowing freedom of movement and choice of travel mode. Although focused on reinforcing transit, the mixed-use and walkable neighborhoods developed under these guidelines would equally support carpools, bus, trolley, biking, walking, and more efficient auto use. Given historic development trends and projections for the future, each of these travel modes will play an important role in solving the city's increasing traffic congestion problems.

A "walkable" environment is perhaps the key aspect of TODs. The alternatives to drive-alone auto use depend on creating comfortable pedestrian environments at the origin and destination of each trip as an incentive to walking, biking, carpooling, or riding transit. No one likes to arrive at work without a car if they cannot walk comfortably from transit to their destination or run a mid-day errand. TODs seek to bring many destinations within walking distance and allow trips to be combined. Placing local retail, parks, day care, civic services, and the transit stop at the center of a TOD reinforces the opportunity to walk or bike for many errands, as well as combine a trip to transit with other stops. Streets lined by trees and building entries that connect transit stops with local destinations also help to make the TOD environment "pedestrian-friendly."

Similarly, it has been shown that a higher percent of people are likely to use transit if they can walk to the station, rather than get in their cars to drive to a "park and ride" lot. Initial sampling in San Diego and experiences in other communities have found that people living or working within 3 to 5 blocks of high frequency bus or trolley service utilize the transit system more than any other group.¹ The TOD design guidelines provide strategies for locating high density employment-oriented development adjacent to trolley stops and moderate density residential-oriented neighborhoods along local bus lines. Park-and-ride lots will continue to be a part of the San Diego transit system, but will not be located within TODs. Transit utilization in TODs will increase over time as the mix of uses reaches build-out, as a transit corridor develops, and as residents and employees see the convenience of transit service. Simultaneously, the type of transit service coming to TODs can mature. It may start with local bus service, add express bus service as ridership grows, and finally provide trolley connections.

¹ SANDAG, 1985 On Board Survey and sample review of 1991 TDM survey of employers by K.T. Analytics, Inc. 1991

From a traffic engineering standpoint, walkable places can affect the average household "mode split," or the percentage of trips taken on foot, bike, bus, trolley, carpool, or by auto. For example, in European communities, auto use is generally between 35% and 48% of all trips; transit trips comprise only 5% to 20% of trips; and pedestrian trips are between 30% to 50% of total trips. Clearly, transit is supported in areas with healthy pedestrian environments. In comparison, the U.S. mode split is 82% via auto, 11% walking, and 3% by public transit.² If we increased walking trips to a modest 20% (only half of Europe's mode split), we could potentially double transit ridership. In order to achieve these goals, we must provide amenities for pedestrians in a manner that works with American lifestyles. The TOD design guidelines provide a flexible approach to making these changes, without eliminating the car.

TODs can reduce auto trip generation and congestion on major roads

The TOD concept recognizes that the majority of trips will continue to be in cars, and thus focuses on reducing congestion on arterials and thoroughfares. Standard suburban development patterns presently force all local shopping, recreation and school trips, as well as work trips, onto the arterial street system. This pattern leads to the congestion neighborhood groups are typically most concerned about. Even without transit, the TOD street system reduces traffic congestion on major streets. The TOD street system still allows convenient access to major roads, but provides an alternative street network for local trips. An interconnected system of local streets, internal to the TOD, reduces congestion on main roads by providing local streets to local destinations. Streets are lined by trees and buildings in which cars are moving at a slower pace than on arterials and collectors. These streets need to be designed to minimize the potential for drivers to use neighborhood streets as through traffic short cuts. Arterials are seen as edges, providing for through traffic and access. On a regional scale, development focused around transit and providing local street networks that avoid arterial streets, should lead to a reduced need for costly road construction in the future.

TODs help solve affordability issues

TODs not only promote alternates to auto use, but are also a formula to provide affordable communities. Communities that are affordable to the environment because they require efficient use of land, help to preserve open space, and reduce air pollution; affordable for the diverse households moving to San Diego because a variety of housing types, at various costs and densities are encouraged in convenient locations; affordable to limited income households because the mix and configuration of uses allow reduced auto dependence and therefore lower auto-related expenses; affordable to businesses seeking to relocate because their workforce can be freed of the gridlock and high housing costs typical in other California metropolitan regions; and affordable to the public taxpayer because TOD infrastructure is efficient, streets are safe, and public amenities are well-used.

TODs work in Redevelopable, Urbanizing and New Growth Areas

TODs are an opportunity to promote efficient development patterns, both in the existing urbanized fabric of the city and in growth areas. Efficient development patterns provide a number of benefits, including minimizing urban sprawl, reducing vehicle miles traveled, improving air quality, and enhancing the social aspect of neighborhoods. TOD concepts can be applied in existing developed areas that have the potential to be "revitalized" with a mix of transit-supportable uses (Redevelopable Sites); small to moderate sized undeveloped parcels within the urbanizing portions of the city that could be "infilled" with new TOD uses (Urbanizing Sites); and areas that are scheduled for urban expansion (New Growth Areas). In each of these

² "Urban Travel Behavior as the Outcome of Public Policy." John Pucher, APA Journal, Autumn 1988.

settings, TOD plans can respond carefully to sensitive environmental resources and to the context and character of existing adjacent neighborhoods.

Transit-Oriented Developments Defined

Transit-Oriented Developments are mixed-use neighborhoods, up to 160 acres in size, which are developed around a transit stop and core commercial area. The entire TOD site must be within an average 2,000 foot walking distance of a transit stop. Secondary Areas of lower density housing, schools, parks, and commercial and employment uses surround TODs for up to one mile.

Retail and office uses in the commercial core of the TOD will vary depending on its location, purpose, and market demand. For example, some TODs may focus on shopping centers with both employment centers and supporting retail and services; commercial core areas in other TODs will be made up of existing commercial shopping streets or a typical neighborhood shopping center with a standard grocery/drug store anchor; and finally, the smallest TODs will focus on a convenience center. Additional TOD uses will also vary based on their location. TODs with high frequency transit service are most appropriate for intensive employment and housing uses; TODs with less frequent transit service will have lower density residential and neighborhood uses. The residential densities and building intensities specified by these guidelines are designed to allow a service-oriented transit system that runs at frequent headways to important destinations in the region.

Proximity to Transit

Proximity to transit is a key factor in determining the suitability of a site for higher density, mixed-use developments. Convenient transit service is necessary to reduce traffic congestion during commute hours; added benefit can be gained by capturing local trips on-site before they reach arterial streets. A fundamental purpose of the TOD concept is to create a land use pattern which will ultimately support transit. In order for TODs to successfully reduce auto travel throughout San Diego, they must be located within easy walking distance of, or within convenient feeder bus connections to dedicated transit lines. Studies by regional transit agencies throughout the country have shown that the greatest pedestrian "capture rate" for public transit occurs when transit stops are within a 10 minute walking distance from home or office, have frequent headways, and are close to a dedicated transit right-of-way. On-board surveys by SANDAG are finding that 80 percent of trolley riders live or work within a 10 minute walking distance³. It is also important that destinations on either end of the trip are pedestrian-oriented and mixed-use. TODs should be designed to be easily accessed by individuals with disabilities.

The City of San Diego is fortunate to have an established transit system that is well-used with opportunities for growth. The transit system has three broad levels of service: the "Trunk Line Network" consisting of trolley or high speed limited stop bus service, the "High Frequency Bus Corridors" which connect neighborhoods with major destinations in San Diego, and the "Feeder Bus Network" made up of local bus lines that connect with the trunk line network or bus corridors that run through residential neighborhoods. TODs must be located on a segment of the Trunk Line Network, along High Frequency Bus Corridors, or on a segment of the Feeder Bus Line Network within 10 minutes transit travel time from the Trunk Line Network or Bus Corridors. These locations offer the greatest opportunity for creating mixed-use destinations that reflect the significant investment necessary to construct the transit system and generate the greatest number of transit-bound trips. Immediate transit service is not essential to successfully

³ SANDAG 1991 On Board Surveys

implementing these ideas, because a system of interconnected streets will be effective at reducing traffic congestion on surrounding arterials and highways.

Urban and Neighborhood TODs

Two types of TOD's may be developed: "Urban TODs" and "Neighborhood TODs." Urban TODs are located on the Trunk Line Network at light rail stops or at express bus stops. Because they are adjacent to the major spine of the regional transit system, these TODs may have a higher percentage of job-generating uses and may be developed at higher commercial intensities and residential densities. Neighborhood TODs are located on high frequency bus routes or along feeder bus lines within 10 minutes travel time from light rail stops or bus transfer stations. These TODs should place a greater emphasis on residential uses and local-serving shopping.

Secondary Areas

TODs may be surrounded by more auto-oriented, low density areas called "Secondary Areas." These Secondary Areas can take advantage of the services within a TOD through an interconnected street system with easy access to the transit stop by foot, bike or car. Secondary Areas will be primarily comprised of standard single-family neighborhoods. These areas may also provide uses that serve TOD residents, such as public schools and community parks. Along major arterials, commercial and employment uses may be located in Secondary Areas to provide additional transit ridership and support TOD core commercial area businesses. Because they are entirely within one mile of the transit stop, Secondary Areas are ideal for bicycle travel to the TODs.

Non-TOD Areas

Some of the urban design concepts addressed in these guidelines would be suitable for projects throughout the city that are striving for greater pedestrian orientation and a reduction in automobile dependence. Please refer to the Implementation Chapter and the associated Council Policy for the long range strategy for incorporating TOD design elements into city-wide policies and regulations.

Functional Settings

Three types of settings have been identified which broadly characterize the physical pattern of development throughout the city: Redevelopable Sites, Urbanizing Sites, and New Growth Areas. These three functional settings represent the range of conditions where TODs could be located. The characteristics of these settings are summarized below:

Redevelopable Sites: A majority of San Diego is urbanized and fully built-out. As land values increase over time, older neighborhoods may gradually transition to new uses and economically underutilized areas may redevelop to more intensive uses. TODs may be able to take advantage of this change to reinforce the transit system with land uses that provide riders and provide incentives to creating pedestrian-oriented environments. Existing on-site uses that are economically viable can serve as the starting point for TODs and in some cases will represent the nucleus for future economic revitalization. Intensification and redevelopment must, however, be balanced with a strong sensitivity to protecting existing neighborhoods and a recognition that additional development is not appropriate in every setting.

Urbanizing Sites: This category represents undeveloped parcels of land that have been "skipped over" in the process of growth and are surrounded by existing development. In many cases these parcels do not have an established street system on-site, but are connected to surrounding neighborhoods or adjacent to existing commercial developments. These sites are often large enough to develop all or a major portion of a TOD; the existing surrounding neighborhoods will then function as its Secondary Area. Many of these sites are still vacant because they have on-site canyons, floodplains and steep slopes. The extent and character of future TOD development will be largely shaped by these features.

New Growth Areas: There are a number of large undeveloped sites within the Planned Urbanizing and Future Urbanizing Areas with planned or potentially viable transit service. These sites should be developed as one or more TODs, with associated Secondary Areas, under the guidance of these Design Guidelines. While New Growth Areas are the easiest to develop with transit- and pedestrian-oriented patterns, they are generally located at the edge of urban development and may ultimately spread the size of the city. Future planning processes will determine how and where TOD designations will be applied. Furthermore, in many cases, transit service to these sites is only at preliminary planning stages and TODs may be required to function for some time without full transit service. Corridor plans, which identify long-term opportunities for TODs along future transit corridors, should be prepared where transit lines pass through New Growth Areas to ensure that the TOD concept is applied in a manner that respects environmental constraints, works with topography, and functions in the interim without strong transit service.

How To Use These Guidelines

The Design Guidelines address a broad range of issues related to site selection, land use patterns, street configuration and design details. The following "decision tree" illustrates how these guidelines should be used, depending on the type of site under consideration:

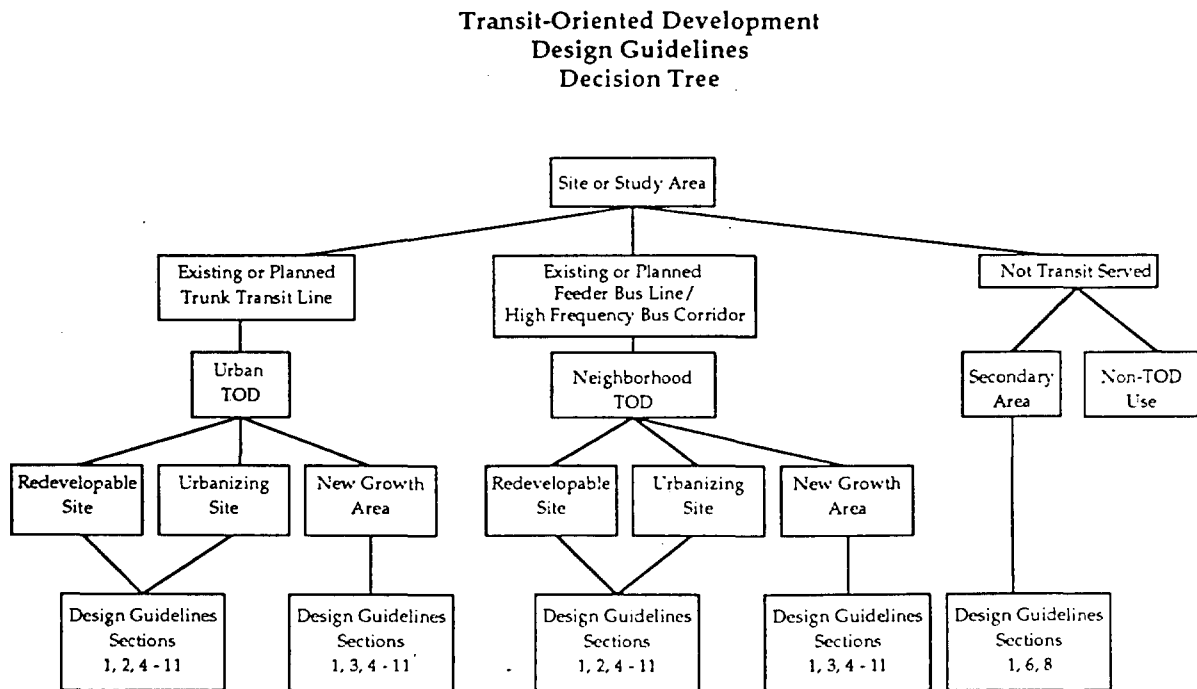

Design Guidelines

1. TOD Definitions and Guiding Principles

Guideline 1A:

TRANSIT-ORIENTED DEVELOPMENT (TOD)

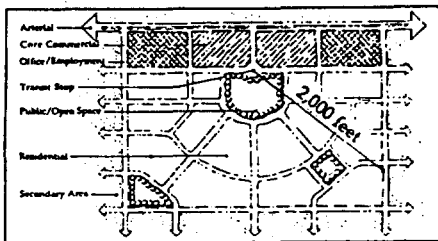

A Transit-Oriented Development (TOD) is a mixed-use community within a typical 2,000 feet walking distance of a transit stop and core commercial area. The design, configuration, and mix of uses emphasize a pedestrian-oriented environment and reinforce the use of public transportation, without ignoring the role of the automobile. TODs mix residential, retail, office, open space, and public uses within comfortable walking distance, making it convenient for residents and employees to travel by transit, bicycle or foot, as well as by car.

Discussion:

TODs can be developed throughout San Diego on undeveloped sites in urbanizing areas, sites with the potential for redevelopment or reuse, and in new urban growth areas. Their uses and configuration must relate to existing surrounding neighborhoods.

TOD sites must be located on or near existing or planned segments of the trunk transit line network or feeder bus line network, yet adequate auto accessibility is also important. The TOD design guidelines establish standards for site selection and development to ensure that TODs succeed in providing a mix of uses, a variety of housing types, and a physical environment that is conducive to pedestrian and transit travel.

The size of a TOD and its average 2,000 feet walking distance from the transit stop must be determined on a case-by-case basis. 2,000 feet is intended to represent a "comfortable walking distance" (± 10 minutes) for a majority of people. In some locations, comfortable walking distance is affected by topography, climate, intervening arterials or freeways, and other physical features. Therefore, the size of a TOD will be greater or lesser depending on surrounding features.

Justification:

TODs offer an alternative to traditional development patterns by providing housing and employment opportunities for the increasingly diverse population of San Diego, and physical environments that facilitate pedestrian and transit access. Developing a network of TODs throughout the City will also serve to strengthen the overall performance of the regional transit system.

Guideline 1B:

**RELATIONSHIP TO
TRANSIT AND
CIRCULATION**

The TOD site must be located on: 1) an existing or designated trunk transit line network; 2) on a high-frequency bus corridor; or 3) on a feeder bus line network within 10 minutes transit travel time from a stop on the trunk line network. Where transit may not occur for a period of time, the land use and street patterns within a TOD must function effectively in the interim and guide the timing and location of future transit lines.

Discussion:

The trunk line network represents the San Diego region's express transit system. It consists of either light rail "trolley" lines or high speed limited stop bus service, with at least a 15 minute frequency of service. TODs on the trunk line network will be located either at light rail or express bus stops.

High frequency bus corridors consist of routes that pass through residential neighborhoods to connect with major destinations (such as existing routes along Park Boulevard and University Avenue). These corridors typically provide 6 to 10 minute headways with bus stops located every 2 to 4 blocks.

The feeder bus line network is a system of timed transfer local bus routes which link to the trunk line network. Transit stops on the feeder bus line network that serve as links to the trunk line, should be within 10 minutes transit travel time (approximately 2 to 3 miles), from a trunk line network stop, with buses running at least a 15 minute frequency of service. In some circumstances, a feeder bus line can be provided by a private transit system that meets the level of service criteria of the feeder bus line network.

The TOD program recognizes that even with an ambitious 40% non-auto mode split, 60% of all trips will continue to be via autos. The land use patterns in TODs, as well as their internal street systems, must plan for on-going auto use. Adequate auto access from arterials and freeways, as well as frequent transit service, will also be an important locational consideration for the more intensive, employment-oriented TODs. Similarly, not all transit stops will be TODs; some stops will be developed as park-and-ride lots or will be located at low-intensity industrial uses.

In many locations transit service is planned, but will not be implemented until well after development occurs. San Diego has the opportunity to guide transit planning by providing the densities necessary to support transit initially. In early years, express bus service can serve planned trolley lines and establish ridership clientele. Land use patterns

should guide transit service planning, rather than expecting transit to come to an area that must be retrofit to meet transit-supportable densities.

Justification:

A fundamental purpose of TODs is to create a land use pattern which will support transit. Studies by SANDAG and other transit agencies have shown that the greatest pedestrian "capture rate" for public transit occurs when transit stops are within a 10 minute walking distance from home or office, have frequent headways, and are close to a dedicated transit right-of-way. It is also important that the destinations are pedestrian-oriented and offer a mix of land uses.

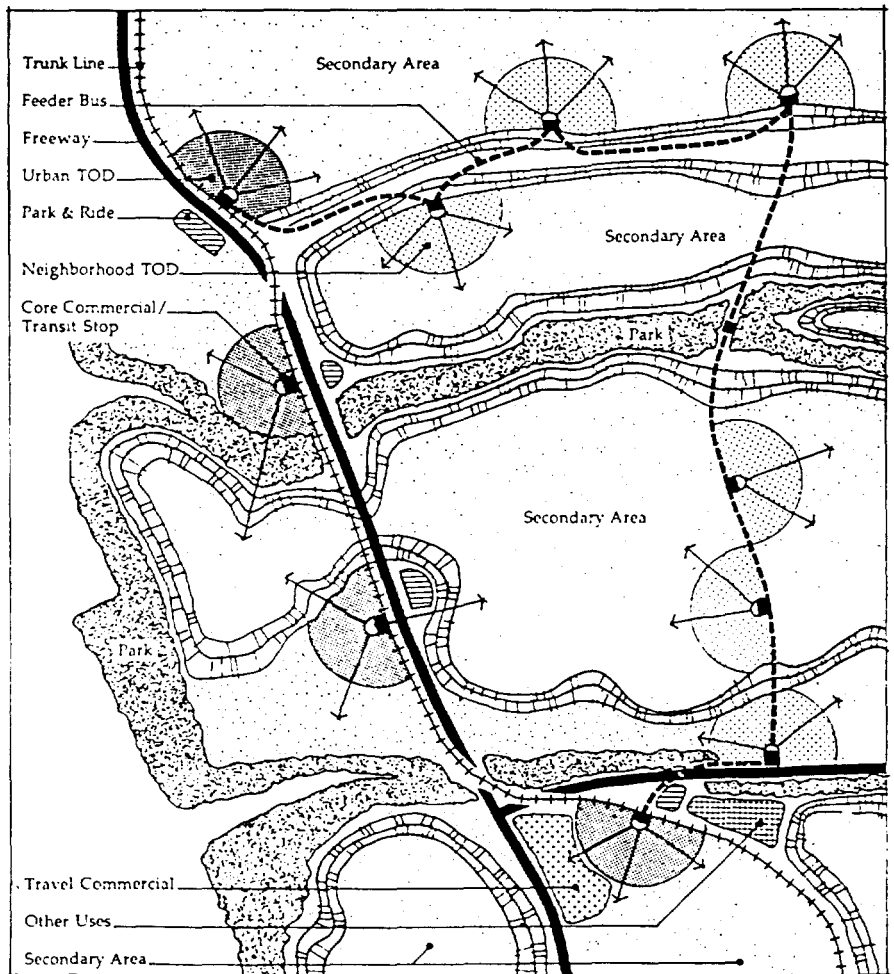

Guideline 1C:

URBAN TOD

Urban TODs are located on the trunk line network, at light rail or at bus stops, and may be developed at high commercial intensities and residential densities.

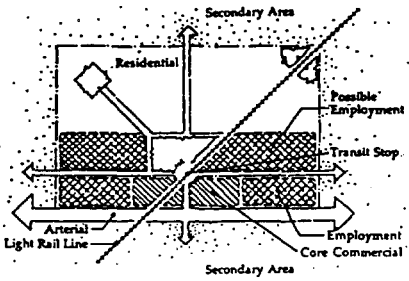

Discussion:

Special site development guidelines are recommended for TODs that are highly accessible by transit to permit higher density residential development and to encourage a higher percentage of job-generating uses. Where Urban TODs are located in existing developed neighborhoods, it may be appropriate to apply the densities and mix of uses recommended for Neighborhood TODs. Urban TODs are typically sited approximately 1 mile apart to meet trolley station spacing guidelines, although they could be sited closer together in certain circumstances. Examples of potential Urban TOD include sites within the Mission Valley and University communities.

Justification:

Each TOD may assume a different character and mix of uses depending on its location within the region and the surrounding land uses. Urban TODs are suitable for job-generating and high intensity uses, such as offices, large-scale shopping centers, and high density housing, because they allow direct access from any location within the transit system without requiring passengers to transfer between modes. Similarly, the intensity of development along the trunk line network should reflect the significant investment necessary to construct the transit system and should generate the greatest number of transit-bound trips.

Guideline 1D:

**NEIGHBORHOOD
TOD**

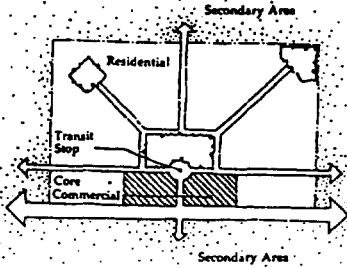

Neighborhood TODs are located on the feeder bus line network within 10 minutes transit travel time (no more than 3 miles) from a light rail stop or express bus stop, or along high frequency bus lines that pass through residential neighborhoods. They should place an emphasis on residential uses and local-serving shopping.

Discussion:

Land use proportions and density standards for Neighborhood TODs encourage sites which are served by local feeder buses or along high frequency bus lines, but are not located along the trunk transit line network. Neighborhood TODs should have a residential and local-serving shopping focus. Neighborhood TODs will typically cluster around a bus stop. Where bus stops are frequent, TODs can be sited close together and form a "corridor" of higher density, mixed-use nodes. Potential Neighborhood TOD sites include parts of Clairemont, Pacific Beach and Mid-City.

Justification:

Neighborhood TODs can help provide affordable communities because they include a variety of housing types to meets the needs of an increasingly diverse population of the city in a land use pattern that minimizes the need for multiple car households. If properly designed, Neighborhood TODs can meet local needs for public facilities and parks, respect the character and quality of existing neighborhoods, and limit inter-community traffic through residential areas.

Guideline 1E:

**REDEVELOPABLE,
URBANIZING AND
NEW GROWTH AREAS**

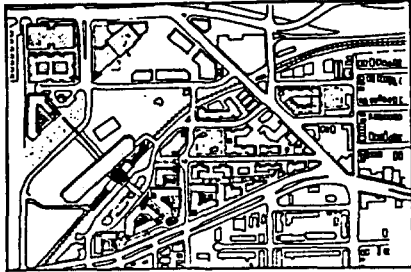

Redevelopable Site

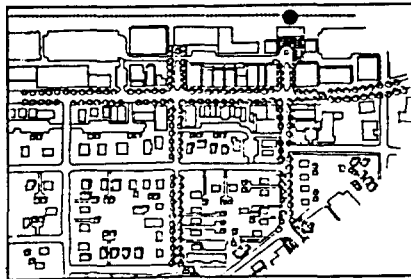

Urbanizing Site

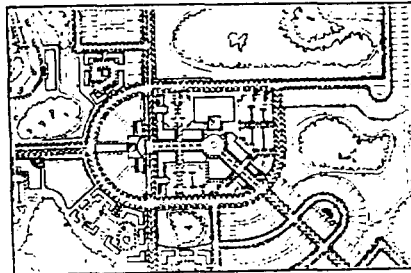

New Growth Area

TODs may be developed on Redevelopable and Urbanizing Sites and in New Growth Areas. Redevelopable sites are developed areas of the city that could be revitalized with new uses and transit service. Urbanizing sites are vacant sites surrounded by existing urban development. New Growth Areas are larger, undeveloped properties on periphery of the city. Community plans, specific plans, and plans for transit corridors should identify appropriate sites in each of these settings for TODs and transit service.

Discussion:

Three types of settings have been identified which broadly characterize the physical pattern of development throughout the city: Redevelopable Sites, Urbanizing Sites, and New Growth Areas. These three functional settings represent the range of conditions where TODs could be located. The characteristics of these settings are summarized below:

Redevelopable Sites: A majority of San Diego is urbanized and fully built-out. As land values increase over time, older neighborhoods may gradually transition to new uses and economically underutilized areas may redevelop to more intensive uses. TODs may be able to take advantage of this change to reinforce the transit system with land uses that provide riders and provide incentives to creating pedestrian-oriented environments. Existing on-site uses that are economically viable can serve as the starting point for TODs and in some cases will represent the nucleus for future economic revitalization. Intensification and redevelopment must, however, be balanced with a strong sensitivity to protecting existing neighborhoods and a recognition that additional development is not appropriate in every setting.

Urbanizing Sites: This category represents undeveloped parcels of land that have been "skipped over" in the process of growth and are surrounded by existing development. In many cases these parcels do not have an established street system on-site, but are connected to surrounding neighborhoods or adjacent to existing commercial developments. These sites are often large enough to develop all or a major portion of a TOD; the existing surrounding neighborhoods will then function as its Secondary Area.

New Growth Areas: There are still a few undeveloped sites within the Planned Urbanizing and Future Urbanizing Areas with planned or potentially viable transit service. These sites should be developed as one or more TODs, with associated Secondary Areas. While New Growth Areas are the easiest to develop with transit- and pedestrian-

oriented patterns, they are generally located at the edge of urban development and may ultimately spread the size of the city. Furthermore, in many cases, transit service to these sites is only at preliminary planning stages and TODs may be required to function for some time without full transit service. Corridor plans should be prepared along transit lines that pass through New Growth Areas to ensure that the TOD concept is applied in a manner that respects environmental constraints, works with topography, and functions in the interim without strong transit service.

Justification:

TODs are an opportunity to promote efficient development patterns, both in the existing urbanized fabric of the city and in growth areas. Efficient development patterns provide a number of benefits, including minimizing urban sprawl, reducing vehicle miles traveled, improving air quality, and enhancing the social aspect of neighborhoods.

Guideline 1F:

**CORE COMMERCIAL
AREAS**

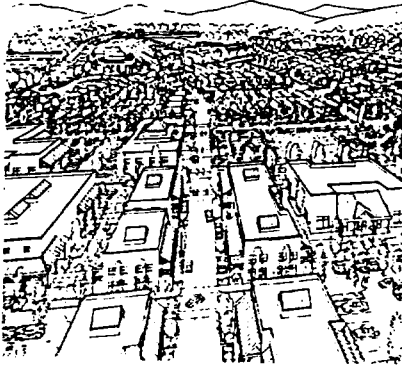

Each TOD must have a mixed-use core commercial area located adjacent to the transit stop and surrounded by TOD residential neighborhoods. At a minimum, the core area should provide convenience retail and civic sites. Larger core areas may also include major supermarkets, professional offices, restaurants, service commercial, entertainment uses, comparison retail, and employment-intensive office and light industrial uses.

Discussion:

The size and location of core commercial areas reflect the anticipated market demand, proximity to transit and phasing considerations. Optional upper floor office and residential uses in the core commercial area increase the mixed-use, round-the-clock nature of the core area. Employment-generating uses, such as stand-alone office uses and employee-intensive light industrial uses may be located adjacent to or amongst the retail component of the core commercial area. The transit stop and core commercial area should be complemented with a "village green" or public plaza which can serve as a focal point for community activities. Secure and convenient bicycle parking facilities should be provided to encourage bicycle access.

Justification:

A commercial core at the center of each TOD is essential because it permits most residents and employees to walk or ride bicycles to obtain basic goods and services. This is particularly advantageous for those without cars and individuals with mobility limitations. Those who still choose to drive to shop will have to go fewer miles and can avoid using arterial streets for local trips. Core commercial areas also provide a mixed-use destination that makes transit use attractive. People are more prone to use transit to get to work if the transit stop is combined with retail and service opportunities.

Guideline 1G:

TOD RESIDENTIAL AREAS

**Housing Mix Alternatives
(18 Dwelling Units/Acre
Minimum Average Net Density)**

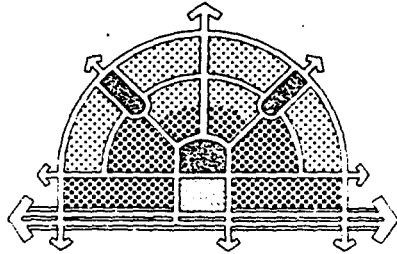

	26 DU/AC	50%
	16 DU/AC	0%
	10 DU/AC	50%

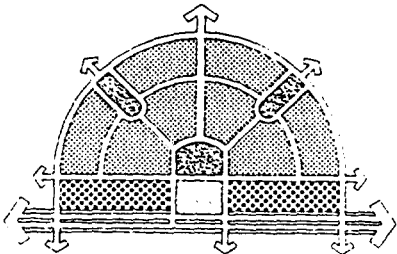

	26 DU/AC	20%
	16 DU/AC	80%
	10 DU/AC	50%

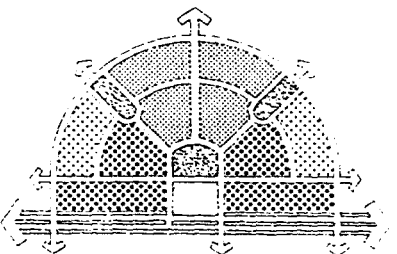

	26 DU/AC	37%
	16 DU/AC	37%
	10 DU/AC	26%

These diagrams illustrate housing combinations where an average net density of 18 dwelling units per acre are achieved. The diagrams are meant to clarify planning principles only and do not represent actual plans.

TOD residential areas include housing that is within a convenient walking distance (average 2,000 feet) from core commercial areas and transit stops. Average minimum densities should vary between 18 and 25 du/net residential acre, depending on proximity to transit, relationship to surrounding existing neighborhoods, and location within the urban area. TOD residential density requirements should be met with a mix of small lot single-family, townhomes and apartments.

Discussion:

TOD residential areas should extend from the core commercial area and transit stop over an area that is an average 2,000 feet in radius, representing a 10 minute walking distance. Net densities are roughly 20% higher than gross densities, once streets and other infrastructure improvements are accounted for. The minimum average density requirements are intended to set a baseline density standard for all TODs; higher average density standards may be adopted by individual community plans to respond to locational differences within the city. community plans, TOD development plans, specific plans and/or zoning studies will clarify how the minimum average density standards are applied to individual sites.

TOD residential areas should contain a variety of housing types and ownership patterns, ranging from small lot single-family homes with carriage units to apartment buildings. For example, a Neighborhood TOD residential area may be a mix of small lot single-family lots with carriage homes (13 du/ac), townhouses (25 du/acre) and apartments (45 du/acre) combined to meet the density requirements. The same strategy of mixing residential product types can be used in Urban TODs.

Justification:

TOD residential areas provide a higher concentration of households in close proximity to transit service and core commercial areas than typical suburban land use patterns. Minimum densities of at least 12 du/net acre are necessary to support local bus service; higher densities are necessary for adequate light rail and express bus service.⁴ To this end, the TOD Concept encourages walking and biking, reduces reliance on the automobile, supports transit service, and creates distinct, identifiable neighborhoods.

⁴"Public Transportation and Land Use Policy." Pushkarev and Zupan. 1977

Guideline 1H:

PUBLIC USES



Public uses are required in each TOD to serve residents and workers in the TODs and neighboring areas. Parks, plazas, and public services may be used in any combination to fulfill this requirement. Small public parks and plazas must be provided at a minimum within TODs to meet local population needs. Roadways and park-and-ride facilities are not applicable towards fulfilling the public use requirement.

Discussion:

Each TOD must contain open space areas available to the public and facilities which serve the needs of the surrounding community. Varying sizes and types of TODs will require or justify inclusion of civic buildings and public facilities. Appropriate public facilities include daycare, libraries, community buildings, police and fire stations, post offices, and governmental services. Public buildings should be placed in central locations, as highly visible focal points, or adjacent to public parks and plazas. Civic uses such as an urban plaza, community center, post office, and library, are best located in the core area in conjunction with retail businesses and offices. Recreation-oriented uses, such as parks, recreation facilities, and community buildings, as well as large parks and schools, should be centrally located with easy access from TOD and Secondary Area residences and the core area. Schools should be placed at the perimeter of TODs and their Secondary Area.

Justification:

The structure of a TOD is built around accessible and convenient public facilities and spaces. A strong sense of community, participation, identity, and conviviality is important to support the sense of safety and comfort within a TOD. Public uses in TODs serve this role by providing meeting places, recreation opportunities and lunchtime picnic spots essential to the vitality of TODs. Kensington Park is a good example of a well-used park that is centrally located in a neighborhood, has good visibility from the street, and benefits by being next to a public library.

Guideline 1I:

MIXED-USE

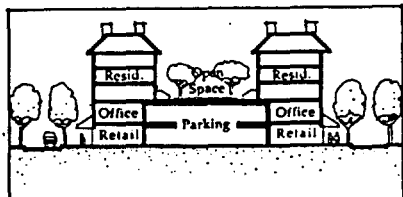

Vertical Mixture of Land Uses

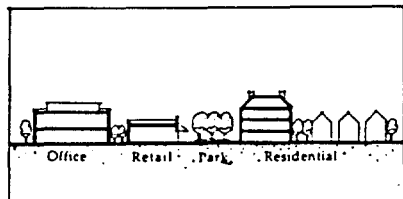

Horizontal Mixture of Land Uses
(within Walking Distance)

All TODs must have a mix of uses arranged horizontally within their boundaries. Vertical mixed-use buildings are also permitted, but are considered a bonus in addition to the basic horizontal mixed-use requirement.

Discussion:

Horizontal mixed-use refers to the "plan view" arrangement of land uses within the TODs. Rather than requiring each building to have two or more uses, the area within the TOD must have residential, retail, public, and possibly office uses.

Vertical mixed-use refers to a building type that provides two or more uses, such as ground floor retail, with residential or office above. This is strongly encouraged in TODs, but is not required.

Justification:

If a neighborhood or employment area has local destinations within convenient walking distance, residents and employees are more likely to walk or bicycle. Furthermore, if local destinations are accessible to drivers without requiring use of the arterial street system, congestion can be reduced.

Vertical mixed-use buildings do contribute to a healthy pedestrian environment, but are much more difficult to implement due to common real estate practices that encourage single-use buildings. For this reason, the TOD concept does not rely on vertical mixed-use to create pedestrian-oriented places.

Guideline 1J:

STREET AND CIRCULATION SYSTEM

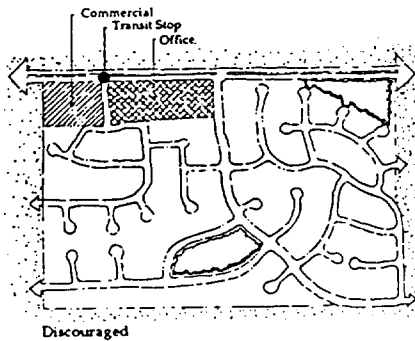
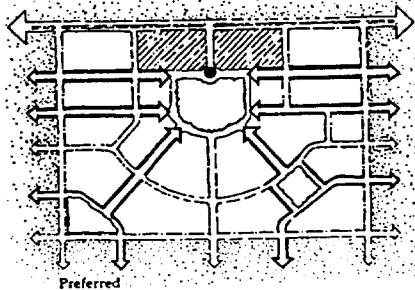

The TOD street system should be clear, formalized, and inter-connected, converging to transit stops, core commercial areas, schools and parks. Cul-de-sac and "dead end" streets should be avoided or connected by pedestrian passages and/or bicycle paths. Multiple and parallel routes between the core commercial area, the TOD, and surrounding Secondary Areas must be provided so that local trips are not forced onto arterial streets.

Discussion:

The street pattern should be simple, memorable and direct, and avoid circuitous routes. Streets should converge near common destinations, such as transit stops, core commercial areas, schools and parks. They should allow autos, bikes, and pedestrians to travel on small local streets to any location in the TOD and to the Secondary Area. Street connections should be designed to keep through community trips on arterial streets and local trips within TODs. The TOD street system should focus streets into the core commercial area, yet minimize the number of light rail at-grade crossings. At no time should an arterial street be the only route to and from an area of the TOD.

Where there is steep topography or other sensitive resources, it may be necessary to curve streets and create some cul-de-sacs. Pedestrian and bicycle paths should be provided to allow residents within the TOD to walk to destinations within the TOD and overall, the principles of multiple and interconnected streets should be adhered to.

Justification:

Clear, formalized, and inter-connected street systems make common destinations visible, and provide the shortest and most direct path for pedestrians and bicyclists. With an inter-connected street system, any single street will be less likely to be overburdened by excessive traffic, thus reducing the need for cul-de-sacs. A street pattern which is circuitous and complex will discourage pedestrians; a street system with landmarks and a simple form will be memorable and familiar.

Guideline 1K:

**GENERAL DESIGN
CRITERIA**



TODs should create pedestrian-oriented environments. In general, buildings should address the street and sidewalk with entries, features and activities, to enliven streets and to create safe, pleasant walking environments. Building intensities and densities should exceed minimum requirements to promote more active commercial centers, to support transit, and to encourage development that addresses the street. Variation is encouraged.

Discussion:

With the possible exception of anchor retail stores, primary building entrances should be physically and visually oriented toward streets, parks and plazas, and not to the interior of blocks or to parking lots or garages. Secondary building entrances oriented toward parking lots are permitted. Where existing viable uses are separated from the street by large parking lots, infill is encouraged at the street. In addition, new internal streets may be constructed closer to existing entries, thus creating a "main street" pedestrian setting.

Highest commercial intensities and residential densities should occur in the TODs. Core commercial areas should be intensive enough to provide a "main street" shopping spine. Furthermore, multi-storied buildings and structured parking are strongly encouraged near transit stops to better utilize the lands adjacent to the transit line and to provide additional transit ridership. As San Diego continues to grow, land economics may make future intensification desirable. Commercial area development plans should include long-term strategies for additional stories and buildings, as well as structured parking. Residential infill should also be possible by permitting some ancillary dwellings in single family residential areas.

Justification:

Buildings must be of a sufficient intensity and density to create safe and active streets enhanced by a sense of enclosure and visual interest, and to support transit. Orienting buildings to public streets will encourage walking by providing easy pedestrian connections, by bringing activities and visually interesting features closer to the street, and by providing safety through watchful eyes and activity day and night. Moderate-to-high intensities and densities also support frequent and convenient transit service; and retail centers can provide a greater variety of goods and services if more residents and employees are within close proximity.

Guideline 1L:

SECONDARY AREAS

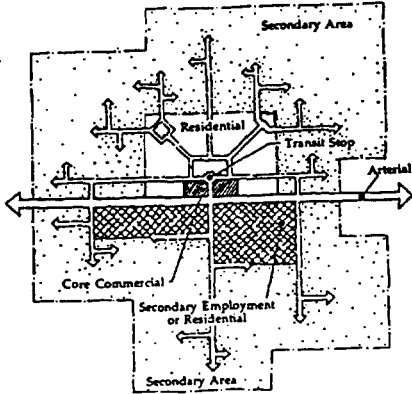

Each TOD will have a Secondary Area adjacent to it which includes lands no further than one mile from the proposed transit stop. The Secondary Area street network must provide multiple direct street and bicycle connections to the transit stop and core area without use of an arterial. Secondary Areas may have lower density single family housing, public schools, community parks, less intensive employment-generating uses, and park and ride lots. Competing retail uses are not allowed in the Secondary Area.

Discussion:

The Secondary Area provides for uses which are not appropriate in TODs because they are more auto-oriented. These areas will, however, provide market support for TOD businesses because Secondary Area residents and workers will shop in the TOD core commercial area and generate riders for the transit system. Employment-generating uses should be located across the street from the TOD transit stop.

Commercial uses which are very similar in nature and market appeal to those located in the TOD's neighborhood-serving core commercial area are not allowed in Secondary Area because they diminish the ability of the TOD to establish a viable retail center. Similarly, very low intensity industrial and warehousing uses which are highly auto-dependent and do not have a sufficient number of employees to contribute to the pedestrian activity of the TOD are not appropriate for Secondary Areas.

Justification:

Single-family residential development is and will continue to be an important land use within the city. These areas typically have too low a density to be adequately serviced by transit. By maximizing street connections to TODs and making it convenient for residents to bike to the transit stop, transit utilization in single-family areas may increase. This is important both in new growth areas and in existing neighborhoods where streets may need to be retrofit. Providing multiple interior street connections between TODs and Secondary Areas will keep many auto trips off arterials. Locating public schools in Secondary Areas will provide a service for the TOD without using valuable transit-accessible land.

Guideline 1M:

OTHER USES

Uses which rely extensively upon autos or trucks for their business are not appropriate uses for TODs or Secondary Areas. Rural residential, industrial uses, and travel commercial complexes should be located outside of TODs or Secondary Areas.

Discussion:

Many uses typically allowed in commercial areas rely predominantly upon auto travel to generate business patrons. These uses, such as auto dealers, freestanding car washes, mini-storage facilities, highway commercial uses, and motels (not including destination resorts), should not be permitted in TODs or Secondary Areas.

Similarly, low employment-generating industrial uses should not be permitted in TODs or Secondary Areas. They are not compatible with nearby residential uses and generate few employees to support core commercial areas. Low employment-generating industrial uses are appropriate where existing industrial activities occur and where major freeway noise impacts are anticipated.

Justification:

In order for more frequent transit to be economically viable, uses near transit stops must have a minimum residential densities and commercial uses must create a high level of pedestrian activity. Land near the transit stop should reinforce transit use by supporting higher density, pedestrian-oriented uses and development patterns. Uses which are primarily auto-oriented are not appropriate for TODs and are better located near major highways.

Guideline 1N:

**COORDINATED
PLANNING**

Regardless of the number of property owners, the application for development of a TOD, or a portion of a TOD, must include a coordinated plan for the entire TOD site. This plan should be consistent with the design guidelines, coordinate development across property lines, and provide strategies for financing construction of public improvements.

Discussion:

While TOD sites in New Growth Areas will often be owned by a single entity, many other sites will consist of numerous parcels under multiple ownerships. To ensure that the TOD area is planned in a coordinated manner, a single TOD plan should be submitted. Property owners may jointly prepare a single TOD development plan or work cooperatively with the City to prepare a TOD specific plan.

Financing plans prepared as part of TOD development plans should distribute the costs of public infrastructure and improvements, as well as compensate landowners whose properties help satisfy the TOD public use requirement, through the use of assessment districts, landscape maintenance districts, and/or homeowners associations.

Justification:

TODs represent a departure from traditional single parcel development and require coordinated planning and implementation of public improvements such as streets, pedestrian paths, bikeways, and plazas.

Guideline 10:

PHASING

TODs must be developed in a balanced phasing pattern. Public areas must be dedicated concurrent with commercial and residential uses.

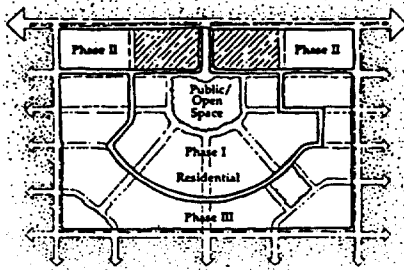

Discussion:

TODs represent relatively large projects which will be executed over several years. The phasing of the project is critical to its success, both as a financial undertaking and as a mechanism to encourage transit use. Smaller increments of development are not only easier to finance, they allow for variety and design excellence, rather than the appearance of mega projects.

To the degree reasonable, infrastructure improvements should be phased consistent with the increment of development. In order to ensure that public uses and amenities are provided in an integrated manner, developers should dedicate sites designated for public uses concurrent with development of commercial and residential uses.

Justification:

The retail uses of TODs are often dependent on the market area developed in the residential and office components of the project. While this core commercial center must often follow the residential development, the land for public facilities and parks can be set aside and developed concurrently to aid in the project's marketing and to supply amenities and services to new residents.

2. Redevelopable and Urbanizing Sites

Guideline 2A:

LOCATION AND PROXIMITY TO TRANSIT

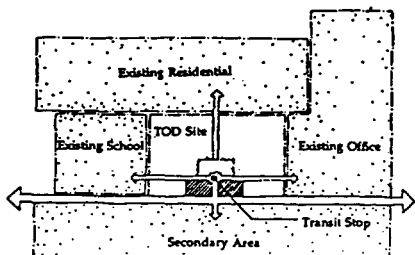

TOD concepts can be applied to Redevelopable and Urbanizing sites located within San Diego's existing urban fabric that are on trunk lines, high frequency bus corridors, or feeder bus lines that are within 10 minutes transit travel time from a trunk line transit stop. Existing infrastructure capacities should be assessed and infrastructure upgrades and other mitigation measures should be implemented which address significant existing traffic, public service, utility, or other infrastructure constraints.

Discussion:

TODs in Redevelopable and Urbanizing areas must be located along existing or planned transit lines within urbanized or urbanizing portions of the city. As discussed in Guideline 1B, transit lines consist of trolley or high speed limited stop bus routes, local bus routes which link to the trunk line network, or high frequency bus corridors that pass through residential neighborhoods.

Redevelopable and Urbanizing TODs should not only develop underutilized parcels, but should also seek to incorporate existing surrounding uses into the form and function of the TOD. New additional uses in the TOD should complement existing development patterns to create walkable, mixed-use districts.

TOD plans in Redevelopable and Urbanizing areas should identify implementation strategies and financing mechanisms for correcting any existing infrastructure capacity and public facility limitations.

Justification:

Implementation of the TOD concept on Redevelopable and Urbanizing sites has the opportunity to transform development patterns that are presently highly auto-oriented into mixed-use, transit-oriented development. Careful site selection and integration of viable, existing uses within the site and its surroundings can help ensure the success and vitality of future TODs. Furthermore, traffic and infrastructure constraints must be addressed if TODs are to function well.

Guideline 2B:

SITE BOUNDARY DEFINITION

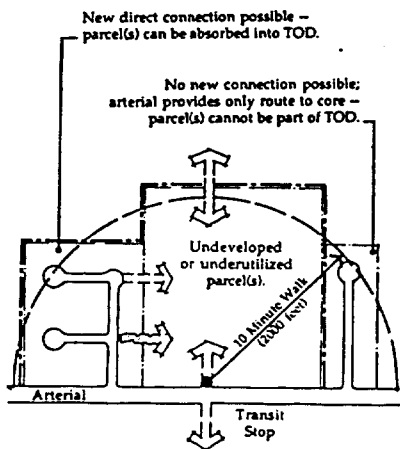

TODs on Redevelopable and Urbanizing sites should be planned in a coordinated manner, regardless of property ownership. Parcels within an average 2,000 foot radius, or 10 minute walking distance, of the transit stop shall be included in the TOD boundary if direct access by street or path can be established without use of the arterial. The size of the TOD area is variable depending on the ability to provide connections. The TOD area must be a minimum of 10 acres, including existing uses that will be incorporated into the overall TOD plan, but not redeveloped because they are already consistent with the TOD design guidelines.

Discussion:

The TOD concept is an important strategy to revitalize neighborhoods along transit corridors. The City and/or property owners can work together to prepare plans for TODs in developed portions of San Diego which are or will be served by frequent transit service.

If a site is suitable for a TOD (i.e. along a transit line, undeveloped or economically underutilized, and has a street system than does, or can be connected to the transit stop), a coordinated plan should be prepared to indicate how the TOD Design Guidelines would be applied to the entire TOD area, regardless of property ownership. In this case, the TOD sites would be defined as the average 2,000 foot area around the transit stop or a 10 minute walking distance. The mix of uses, density and intensity standards, and other design guidelines would apply to this entire area.

If a candidate site does not have a street system that can provide direct auto or walking connections to the core area and transit stop, the TOD site must be strictly limited to the parcels that do provide street or walking connections. This site may be a single property, but must be a minimum of 10 acres in size. All TOD-required uses must be provided within this smaller site area.

Sufficient vacant or redevelopable land must be available in the TOD site to allow full application of the TOD development standards. In Redevelopable areas, there should be a mix of underutilized properties than could be redeveloped to more intensive uses, as well as economically healthy uses. On Urbanizing sites, the undeveloped parcel should be surrounded by uses that fit with the TOD concept. Adjacent existing uses, such as employment or multi-family housing, can essentially function as part of the TOD or its Secondary Area if their intensities and densities are consistent with the TOD design guidelines.

Justification:

TODs on Redevelopable and Urbanizing sites have the advantage of being located adjacent to existing development and in areas already served by public infrastructure. Given the importance of this strategy, the City should take the lead to encourage preparation of coordinated plans that go beyond the interests of a single property owner and consider the health and vitality of neighborhoods. A 10-acre site can function as a TOD, but will have less overall benefit to the transit system and neighborhood environment. At less than 10 acres, however, the development cannot function effectively as a TOD.

TODs in Redevelopable and Urbanizing areas may be developed on smaller sites than TODs in New Growth Areas because large sites are generally not available in developed portions of the city and because these TODs will generally be enhancing existing effective transit service, rather than developing new transit lines and new patterns of transit ridership.

Guideline 2C:

**INTEGRATION OF
EXISTING ON-SITE USES**

Existing on-site uses on Redevelopable and Urbanizing sites should complement the mix of uses and the pedestrian and transit orientation of the TOD. Uses which are complementary, and economically and physically viable, should be incorporated into the TOD development plan. If necessary, improvements should be made to make these uses more compatible with TOD concepts. Existing low-intensity and auto-oriented uses that relate poorly to pedestrians should be redeveloped to be consistent with the TOD's compact, pedestrian-oriented character.

Discussion:

In many cases, existing uses will have economic potential to continue operation within the context of a designated TOD site. The condition, density and intensity of these existing uses must be compatible or be made compatible with pedestrian and transit travel. Uses which rely solely on auto trips, such as gas stations, car washes, storage facilities, motels, or low-intensity industrial uses, are not likely to contribute to pedestrian activity in the TOD and should be discouraged and/or placed in structures with other pedestrian-oriented uses.

TOD site plans should integrate existing uses by respecting their on-going operations, basic access requirements, and, if appropriate, existing building massing and architecture. For example, the Palm Avenue Trolley Station in Nestor could potentially redevelop as a TOD. Careful planning would be necessary to integrate existing viable uses into a pedestrian-oriented master plan. Site improvements may be required to make these properties more consistent with TOD requirements. Infill buildings may be needed to meet density and intensity requirements and to better address streets. Safe, direct and pleasant pedestrian connections should be provided to surrounding areas. Site landscaping and building frontage treatments may also be needed to enhance streets and mitigate areas where streetside conditions, such as parking, blank walls and service entries, are unavoidable. If these guidelines cannot be met initially, plans for implementing necessary improvements over time must be submitted with the TOD project application.

Justification:

TOD development allows for infill and redevelopment of sites that may have been skipped over in the process of urban growth; this type of "reuse" is an important strategy for minimizing urban sprawl. Many existing uses can serve as a starting point for TODs and may provide the nucleus for future economic revitalization.

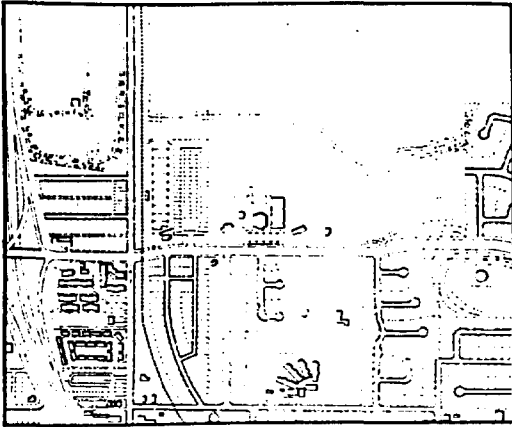

Before

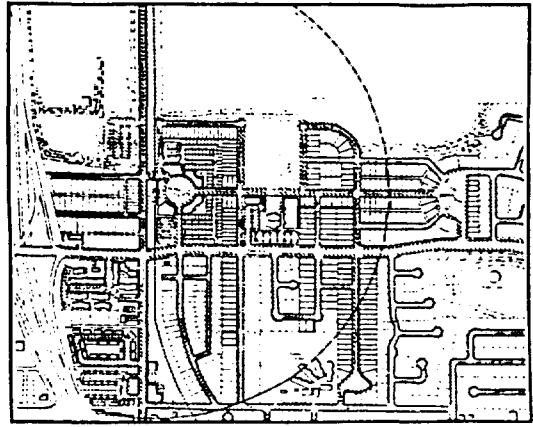

After



Before

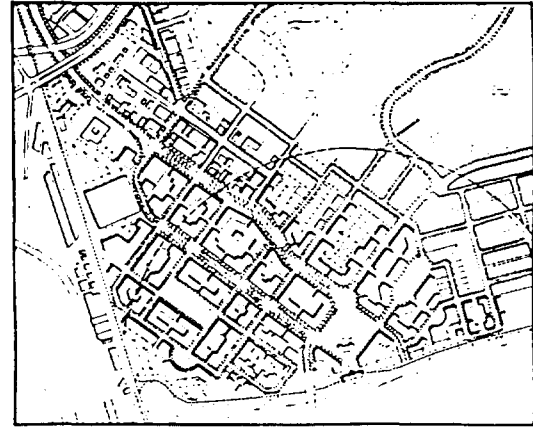

After

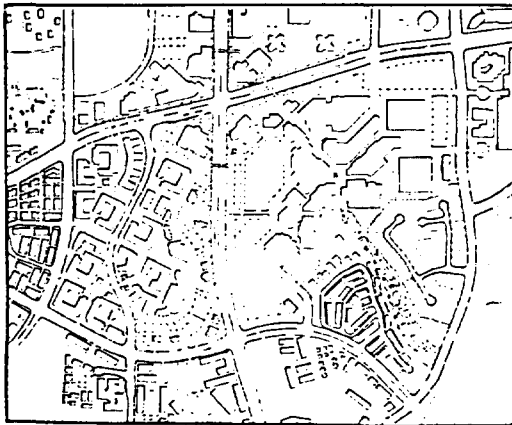

Before

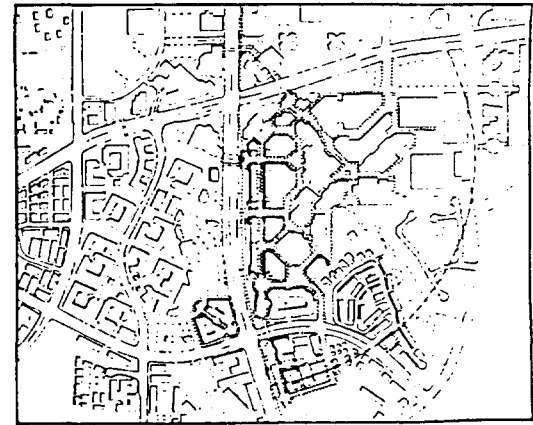

After

Integration of Existing Uses in Redevelopable and Urbanizing Sites

Guideline 2D:

MIX OF USES

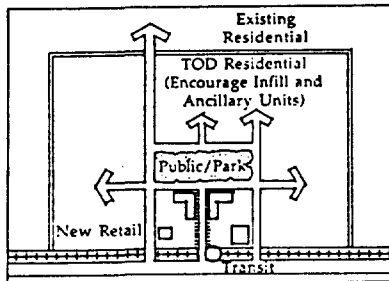
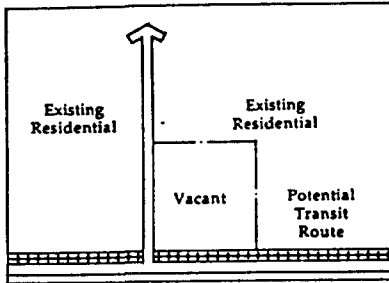

Compliment existing residential areas with new commercial and public uses.

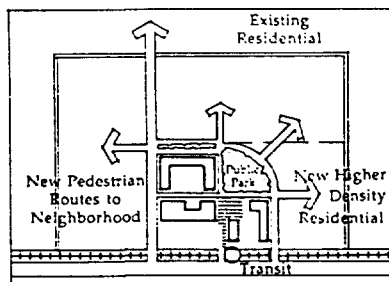
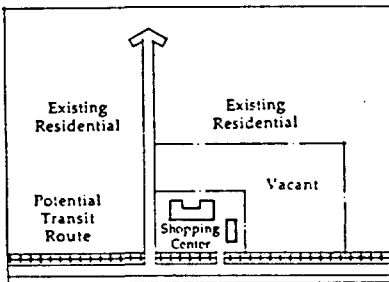

Compliment existing commercial centers with higher density housing.

New uses on Redevelopable and Urbanizing sites should complement existing on-site and surrounding uses, yet seek to achieve a proportion of uses that will stimulate pedestrian activity and create mutually reinforcing land use patterns. Public, core commercial and residential uses must be provided at a minimum.

Discussion:

All TODs must be mixed-use areas. In Redevelopable and Urbanizing areas, some on-site uses may fit with the TOD concept; others may not. Planning for a Redevelopable or Urbanizing TOD site should first identify the uses that do fit and identify sites for new uses that are missing from the existing land use pattern. Ultimately, the mix of uses surrounding the transit stop at Redevelopable and Urbanizing sites should seek to achieve the following minimum requirements:

Use	Neighborhood TOD	Urban TOD
Public	10%	10%
Core	10%	30%
Housing	40%	20%

Note: All percentage ranges are based on site area, rather than square footage of building area.

This recommended proportion of uses is based on site area and does not preclude additional upper floors with different uses.

The ultimate mix of land uses and appropriate densities and intensities should be clarified in a site-specific planning process, in order to address site-related issues such as community context, topography, infrastructure capacities, transit service frequency, and arterial/freeway accessibility. Special care should be taken to respect the context of the site and the character of surrounding existing neighborhoods. The 10% public use component is considered a goal and should include land devoted to parks, plazas, open space, and public facilities.

Justification:

The required proportion of uses is designed to encourage pedestrian activity, yet allow flexibility to integrate existing uses and create TODs with different use emphases.

Guideline 2E:

RETROFIT OF EXISTING STREETS FOR PEDESTRIAN, BICYCLE AND AUTO CONNECTIONS

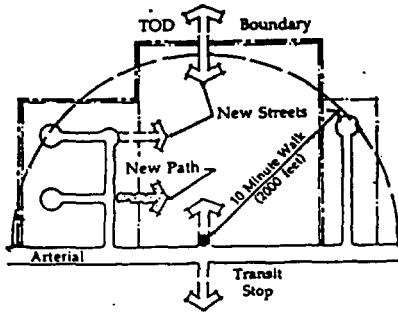

Existing on-site pedestrian, bike, parking, and auto circulation systems should be redesigned to encourage pedestrian/bike access between uses, and public spaces in TODs and Secondary Areas.

Discussion:

On sites that will be retrofit or redeveloped into TODs, existing roadways and pedestrian networks may need to be redesigned to facilitate pedestrian access between buildings and transit, regardless of parcelization patterns. Connections to the core and transit, and between the TOD and surrounding areas are especially critical. Improvements should be made to open walking paths between uses, to protect important vistas, to connect with existing trail systems, and to slow auto traffic. Handicapped access strategies should be incorporated into all street and pathway retrofits. In Carmel Valley and other auto-oriented suburban areas, pedestrian access could be improved by opening key cul-de-sacs to foot and bicycle traffic. In areas dominated by "superblocks" new internal streets could be built to provide pedestrian-friendly connections to workplaces and other destinations.

Justification:

Every effort should be made to encourage and facilitate pedestrian access at sites that are redeveloped into TODs. In some cases this may require redesigning streets and pedestrian systems. Connections between TODs and surrounding areas are vital to providing all of the advantages that a walkable, mixed-use and transit-oriented development can provide.

Guideline 2F

**PROXIMITY OF
COMPETING RETAIL**

As much as possible, new neighborhood and convenience retail centers should be incorporated into TODs and the extent of competing existing "strip commercial" areas should be limited. New competing retail uses outside of TODs should be strictly limited within 1 mile of the TOD core commercial area.

Discussion:

In order for the core commercial area of a TOD to attract major anchor tenants and be economically viable, new competing retail centers must be limited through zoning amendments within the TOD's market area. This provides an incentive for development of TODs in Redevelopable and Urbanizing areas and is a key guideline to enable linear areas to function as TODs. Strip commercial uses that extend beyond a 10 minute walking distance of a transit stop should be limited so that businesses that fit into the TOD can capitalize upon their location and proximity to transit.

Justification:

TODs depend on retail uses for a focus and pedestrian destination. Competing centers in locations which do not support transit or pedestrian-oriented neighborhoods can diminish the opportunity to build transit-oriented mixed-use centers. San Diego's present system of strip commercial areas, particularly along bus routes such as El Cajon Boulevard, should be examined to determine whether the location of these commercial uses may be working in conflict with the goals to promote transit usage, encourage walking or biking for some daily trips, and building a network of streets that allow auto users to travel to local shopping trips on local streets.

3. New Growth Areas

Guideline 3A:

LOCATION AND PROXIMITY TO TRANSIT

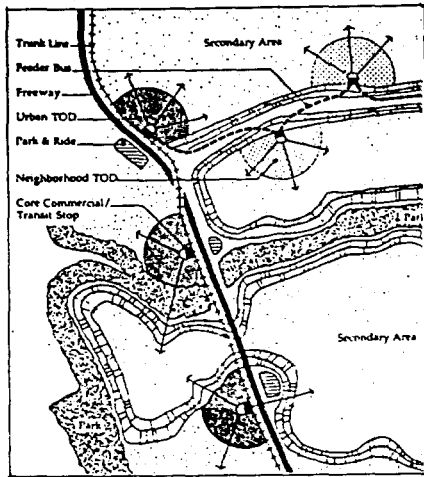

New Growth Areas are located within Planned Urbanizing and Future Urbanizing Areas. TODs within New Growth Areas must be located on an existing or designated trunk line, along a high frequency bus corridor, or on a feeder bus line network within 10 minutes transit travel time from the trunk line network. New Growth Areas may be large enough to create a network of Urban and Neighborhood TODs, as well as surrounding Secondary Areas. TODs may not be used to justify "leap frog" development.

Discussion:

There is still some undeveloped land in Planned Urbanizing and Future Urbanizing areas within the City of San Diego. Development within these areas should be located along existing or planned trunk transit lines, and developed as TODs and associated Secondary Areas as part of a strategy to maximize preservation of open space, focus development potential into pedestrian-oriented patterns that can be served by transit, and limit urban sprawl. While some sites may only have sufficient land to develop a single Urban or Neighborhood TOD, many sites are large enough to create a network of TODs, each served by transit, thus stimulating a significant positive impact in local travel behavior and congestion trends.

Because it may be a number of years before transit reaches some New Growth Areas, projects should be planned to accommodate both trunk line and feeder bus service. In initial years, trunk line service may be provided in the form of express busses, with later conversion to light rail. Rights-of-way should be reserved for light rail, exclusive bus lanes, bus turn-outs and transit stop facilities.

Justification:

The TOD Concept is a strategy to promote efficient and environmentally sensitive development patterns in newly-developing areas. Because these sites are relatively free of existing land uses, New Growth Areas offer the greatest opportunity for creating mixed-use destinations and interconnected street systems. Constraints generated from topography and sensitive habitat can be overcome by carefully selecting opportunity sites and by curving streets to relate to the topography. A fundamental premise of TODs, however, must be to limit sprawl by clustering development within planned urban growth areas.

Guideline 3B:

SITE BOUNDARY DEFINITION

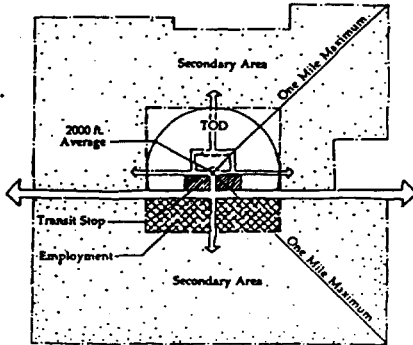

TODs in New Growth Areas should include an area with an average 2,000 foot radius from the transit stop or a 10 minute walking distance. The Secondary Area may contain land no further than one mile from the transit stop.

Discussion:

The TOD site should be an average 2,000 feet from the transit stop. The majority of the site should be within this average, but the total area will vary based on parcel size, topography and other intervening features. Oddly shaped parcels may extend the site boundary beyond 2,000 feet to include areas which are the equivalent of a 10 minute walking distance; sites affected by topography or adjacent to freeways or arterials may be smaller. The distance from the transit stop to the outer boundary of the Secondary Area may be no greater than one mile.

Justification:

To encourage transit use, the transit stop should be very convenient and highly accessible by foot or bicycle from all areas of the TOD. 2,000 feet is considered the greatest distance within which a significant percentage of trips can be captured by transit, walking, or bicycling, rather than auto. In Secondary Areas, one mile is an easy biking distance to the transit stop.

Guideline 3C:

SITE SIZE AND PHYSICAL CHARACTERISTICS

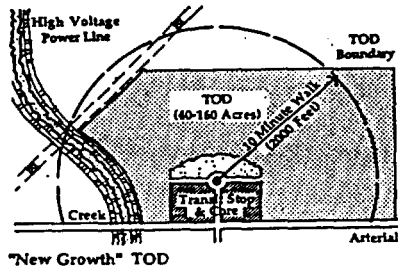

TOD sites in New Growth Areas must be at least 40 acres, and no more than 160 acres, in size. These TOD sites must be complemented by surrounding Secondary Areas. Larger sites may be developed as a series of TODs and Secondary Areas along transit corridors.

Discussion:

TOD sites in New Growth Areas may consist of 40 to 160 acres of land that is wholly undeveloped or has some minor amount of existing uses. Sites may consist of parcels in multiple ownerships provided that the planning for the designated TOD site is coordinated among the property owners. Secondary Areas must be located around TOD sites.

Justification:

In New Growth Areas, 40 acres is considered the minimum area necessary to develop a TOD that can function as a mixed-use transit-oriented destination. 160 acres is equivalent to a 2,000 foot radius, which is a distance most people are willing to walk without hesitation to a transit stop.

Guideline 3D:

DISTRIBUTION OF TODS

TOD core commercial areas with major competing retail centers should be spaced a minimum of one mile apart and should be distributed to serve various growth subareas.

Discussion

TODs should be distributed throughout a New Growth Area in a pattern that allows the greatest number of residents access to a variety of shopping opportunities. TODs should also be distributed to permit residents to walk to retail and public facilities without having to cross an arterial street, whenever possible. The one mile spacing guideline relates to both the market area necessary to support a grocery store; (often the anchor store in a neighborhood shopping center), as well as the typical spacing for trolley stops. Shopping centers with uses that are not directly competing may be sited closer than one mile apart.

Justification

Appropriate TOD spacing provides convenience retail opportunities that are within an easy walk for most residents, also ensures the viability of the retail centers, and better links transit stops to concentrations of residents and core commercial services.

Guideline 3E:

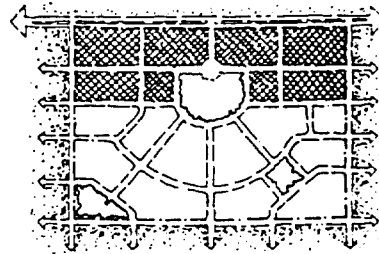
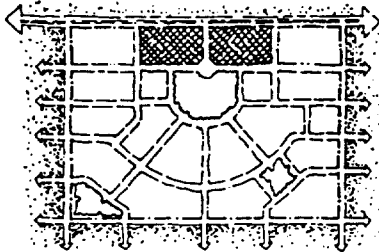

MIX OF USES

Neighborhood TODs

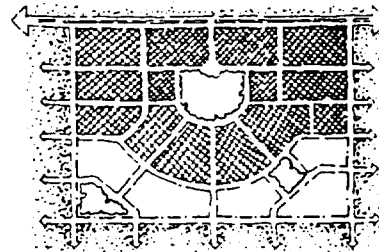
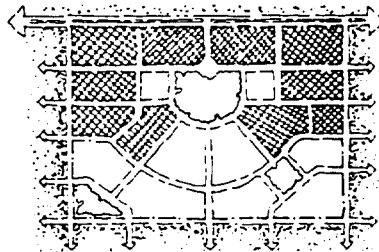

Urban TODs

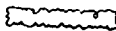

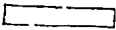
Public 
 Core 
 Housing 

All TODs must be mixed-use areas and contain a minimum amount of public, core commercial and residential uses. The following is a list of land use areas within the TOD and minimum site area requirements:

Use	Neighborhood TOD	Urban TOD
Public	10%	10%
Core	10%	30%
Housing	40%	20%

Note: All percentage ranges are based on site area, rather than building area.

Discussion:

All TODs must be mixed-use. In addition, a certain minimum proportion of uses is required to stimulate pedestrian activity and to provide economic incentives for developing with mixed-use patterns. The proportion of uses is based on site area and does not preclude additional, different uses on upper floors. A minimum amount of retail, housing and public uses are required in all TODs. The 10% public use component is considered a goal and should include land devoted to parks, plazas, open space, and public facilities. The different mix of uses for Neighborhood TODs and Urban TODs is intended to reflect the variations in intensity and type of development desired at these sites.

The mix of land uses and appropriate densities and intensities should be clarified in a community or specific planning process, in order to address site-related issues such as community context, topography, infrastructure capacities, transit service frequency, and arterial/freeway accessibility. Special care should be taken to respect the context of the site and the character of surrounding existing neighborhoods.

Justification:

The required proportion of uses is designed to encourage pedestrian activity yet allow flexibility to create TODs with different use emphases, such as primarily residential TODs (Neighborhood TODs) and TODs which emphasize job-generating uses (Urban TODs).

4. Core Commercial Areas

Guideline 4A:

CORE COMMERCIAL AREAS

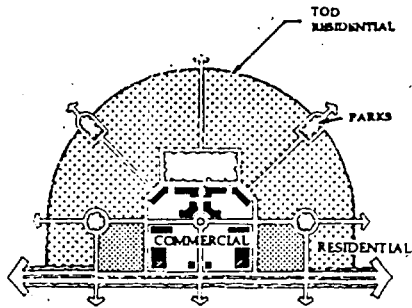

Comparison Center

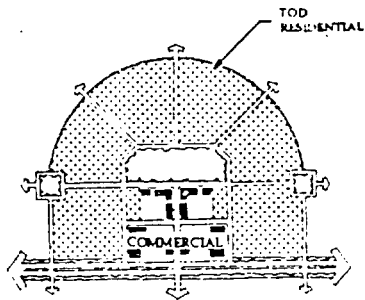

Neighborhood Center

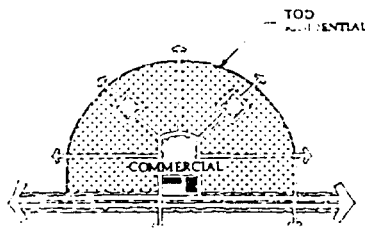

Convenience Center

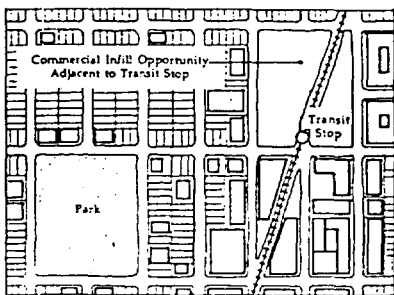

Infill Opportunity

Each TOD must have a mixed-use core area containing ground floor retail and commercial space that occupies at least 10 percent of the total TOD site area adjacent to an anticipated transit stop. A minimum of 10,000 s.f. of retail space must be provided within 1/8 mile of the transit stop. The location of the core commercial area within the TOD is flexible.

Discussion:

Core commercial areas are required in every TOD and must be located adjacent to an anticipated transit stop. Street-level retail and service commercial space should form a pedestrian-oriented "main street" that is accessible from the surrounding TOD without requiring pedestrians or autos to use an arterial street. Stand-alone office and employee-intensive light industrial uses should be located adjacent to the shopping portion of the core commercial area. In redevelopable areas where a connecting pedestrian-oriented street is not possible, at least one pedestrian pathway is required from surrounding areas. Core commercial areas should also be designed to encourage shopping to and from the transit stop or at mid-day by office workers.

The size and mix of uses in each core commercial area can vary, depending on the size, location, and overall function of the TOD in the region. It should, at a minimum, serve as a transit destination and convenience shopping area for TOD and Secondary Area residents and employees. Commercial uses, do not however, need to be concentrated in a single location. Appropriate uses include retail shops, professional offices, service commercial uses, restaurants, cinemas, health clubs, and other entertainment facilities. Small hotels, pensioners, and single room occupancy hotels are also encouraged in TODs to provide a greater choice of accommodations near potential transit destinations and to provide needed housing.

Types of commercial centers that can occur in TODs include: convenience shopping and services (10,000 to 15,000 sf); neighborhood centers with a supermarket, drugstore and supporting uses (80,000 to 140,000 sf); specialty retail centers (60,000 to 120,000 sf); and community centers with convenience shopping and department stores (120,000 s.f or greater). Other employment-generating uses can be located within the core commercial area to provide a balance to shopping and residential uses. New types of anchor-less retail centers may also develop as a

result of new markets produced by the configuration of TODs, workers in the TOD, and transit accessibility.

Justification:

Mixed-use core commercial areas are the primary link between transit and land use. A TOD must have sufficient retail and commercial space to form a useful shopping center and provide opportunities for residents and employees to run errands, during lunch-time or to and from work. Without shopping opportunities within convenient walking distance, residents and workers will use their cars for more trips and will lose an incentive to use transit. Core commercial areas must vary in size and character to respond to market considerations.

Guideline 4B:

OFFICE INTENSITIES

Office intensities in core commercial areas without structured parking must have a minimum 0.35 Floor Area Ratio (FAR) and may not exceed 0.60 FAR. Structured parking is strongly encouraged in both Neighborhood and Urban TODs; maximum FARs should be set by community plans.

Discussion:

As land values in the San Diego region rise, structured parking in a number of locations will become economically feasible. This guideline encourages development of multi-story buildings with structured parking, thereby allowing more efficient use of land in the TOD. The following table establishes guidelines for F.A.R.s in office areas.

	Without Structured Parking		With Structured Parking	
	Min.	Max.	Min.	Max.
Urban TOD	0.35	0.60	0.50	To be set by community plans
Neighborhood TOD	0.35	0.60	0.50	

Justification:

Office areas should promote efficient utilization of land near transit stops. These floor area ratios encourage multi-story buildings and structured parking whenever possible. Larger office areas should be located in Urban TODs to create a major focus of symbiotic uses. Smaller, local-serving office areas create opportunities for small businesses in close proximity to retail and transit.

Guideline 4C:

CORE COMMERCIAL CONFIGURATION

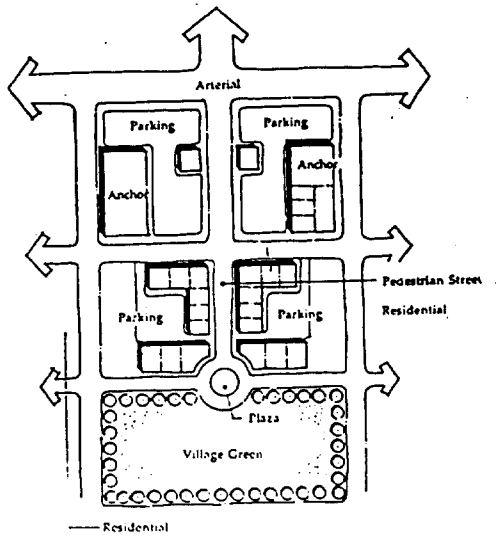

The configuration of shops in the core area must seek a balance between pedestrian and auto comfort, visibility, and accessibility. While anchor stores may orient to an arterial and parking lots, smaller shops must orient to pedestrian "main streets" and plazas.

Discussion:

Core commercial areas should be configured to allow standard parking quantities, access and visibility for the car, as well as a convenient path for local pedestrians. Often, the smaller shops can turn to form a pedestrian-oriented "main street" with streetside parking and rear parking lots. This "main street" forms a pleasant place to walk, and should connect the residential areas and parks with the shops and transit stop. Simultaneously, the edge of the core fronting the arterial may house larger parking areas and anchor stores in locations visible from arterials. Anchor stores are encouraged to provide entries to both their parking lot and the pedestrian-oriented shopping street.

Justification:

The traditional form of suburban retail centers has been oriented entirely to the auto and parking. Smaller shops are dependent on their orientation to the anchor stores when arrival is only by car. TODs offer the opportunity for a more diverse patronage, both from the traditional auto/anchor and from the walk-in neighborhood and transit activity. If the TODs are to attract foot traffic to local shops, the configuration of streets, entrances, and parking must provide a comfortable route for the pedestrian. Traversing large parking lots and access roads designed for heavy auto traffic will discourage the pedestrian. Configurations which provide traditional "main street" sidewalk storefronts in combination with arterial-oriented anchors can provide for both pedestrians and auto accessibility.

Guideline 4D:

**COMMERCIAL
BUILDING SETBACKS**

Building setbacks from public streets should be minimized. Setbacks should reflect the desired character of the area and bring buildings close to the sidewalk.

Discussion:

Buildings in core commercial areas should be encouraged to build to the sidewalk edge whenever possible. Anchor tenants in Urban Growth areas, such as supermarkets, should not be strictly held to this requirement because more auto trips are expected to serve heavy load shopping and lenders often require visible surface parking. The Ralphs store in the Uptown District in Hillcrest is a good example of a compromise. In this case, only a small amount of parking is visible from the street; most of it is underground. Parking areas and parking garages should be recessed or placed to the rear of buildings. Larger setbacks of up to 20 feet should be permitted for office buildings and streetside outdoor cafes and patios in core commercial areas.

Justification:

The street and sidewalk is the main pedestrian activity center. Minimal setbacks bring buildings close to the street and the pedestrians. This defined and close edge enlivens commercial areas by encouraging window shopping and streetside activity. This can be seen in Hillcrest, La Jolla, Mission Boulevard and other areas of San Diego.

Guideline 4E:

**COMMERCIAL
BUILDING FACADES**



Building facades should be varied and articulated to provide visual interest to pedestrians. Street level windows and numerous building entries are required in the core commercial area. Arcades, porches, bays, and balconies are encouraged. In no case shall the streetside facade of a building consist of an unarticulated blank wall or an unbroken series of garage doors. Building materials should convey durability and permanence, and should be suitable to the San Diego climate.

Discussion:

Varied and interesting building facades are key to making a place "pedestrian-oriented." Building designs should provide as much visual stimulus as possible, without creating a chaotic image. Buildings should incorporate design elements at the street level that draw in pedestrians and reinforce street activity. Facades should vary from one building to the next, rather than create an overly unified frontage. Building materials such as concrete, masonry, tile, stone, and wood should be encouraged; glass curtain walls and all reflective glass should be discouraged.

Justification:

Streets with monotonous and unarticulated building frontages are not conducive to pedestrian activity and make walking less appealing. Streetside buildings should encourage window shopping, heavy foot traffic in and out of stores, and people-watching from outdoor seating areas, as is prevalent in the Gaslamp Quarter downtown.

Guideline 4F:

COMMERCIAL BUILDING ENTRIES

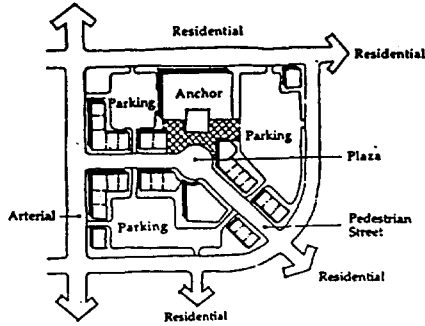

Primary ground floor commercial building entrances must orient to plazas, parks, or pedestrian-oriented streets, not to interior blocks or parking lots. Secondary entries from the interior of a block will be allowed. Anchor retail buildings may have their entries from off-street parking lots, however, on-street entries are strongly encouraged.

Discussion:

Entries into small shops and offices should orient directly onto a pedestrian-oriented street. Buildings with multiple retail tenants should have numerous entries to the street; small single entry malls will be discouraged. Off-street parking should also be located at the rear of buildings with "paseos" leading to the street and primary entrances. Handicapped access must be incorporated into the overall commercial area design.

Some retail anchor stores (above 30,000 s.f.), such as neighborhood grocery stores, need parking lot access to the primary entry. This will be conditionally permitted if pedestrian access to the entry is provided from the street and pedestrians are not required to walk from the street through the parking lot to enter the store. Along walls without entries, building elevations must include windows, display areas, and/or be lined with small retail shops; secondary retail signage along these walls is also permitted.

Justification:

The pedestrian life of a building is at its entry. If the entry orients to parking lots, it steals the activity and life from the street, the main pedestrian route, while signaling that auto access is preferred.

Guideline 4G:

**UPPER STORY USES
IN CORE COMMERCIAL
AREAS**

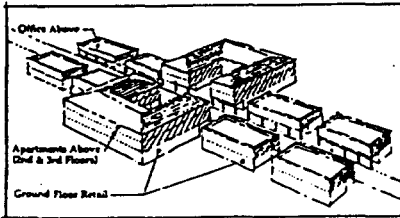

Retail developments in the core commercial area may add two additional floors of residential and/or office uses, as determined by community plans. When using this bonus, the intensity of the retail use must not be reduced, required retail parking may be reduced or eliminated, parking for residential units and office space must be added, and the buildings must be consistent with these design guidelines.

Discussion:

This density bonus for retail buildings is designed as an incentive for developers to provide office and residential uses in the core commercial areas. The amount of upper floor office or residential uses may be determined on a site-specific basis through the community plan or specific plan process. Special care must be given to the design of residential units to ensure privacy and security.

Justification:

Taller buildings are encouraged in the core commercial areas to provide visual interest, a more urban character, street security at night, and to concentrate pedestrian activity. In addition, upper floor residential and/or office space can support the retail by bringing a greater number of lunch-time and after-work shoppers.

5. TOD Residential Areas

Guideline 5A:

RESIDENTIAL MIX

A mix of housing densities, ownership patterns, price, and building types is desirable in a TOD.

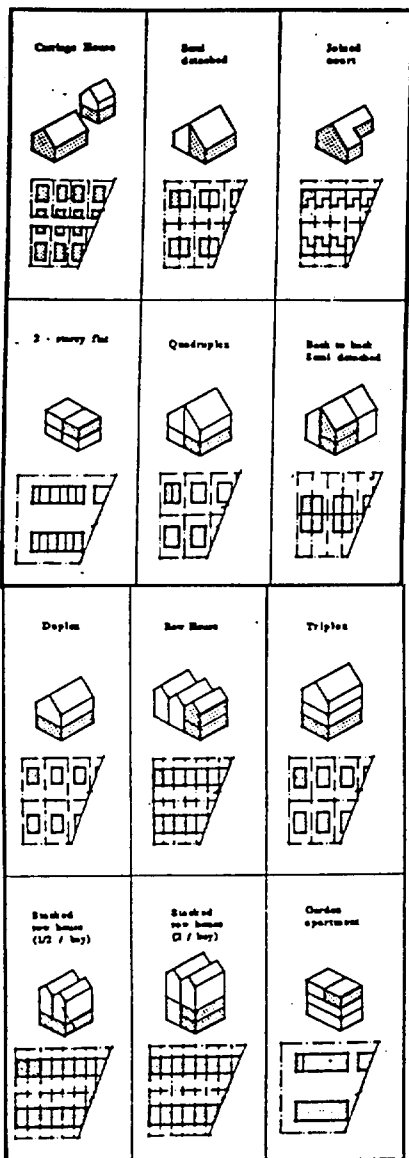

Diagram by Jack Diamond

Discussion:

While each TOD will take on a different character and will have a different proportion of single-family and multi-family densities, care should be taken to provide a variety of housing types, costs, and ownership opportunities within each TOD. The residential portion of the TOD can be a combination of small lot single-family units (such as presently found in older part of San Diego), duplexes, townhouses, and apartment buildings.

Justification:

In order for TODs to be affordable to the diverse range of households in San Diego, TODs must provide a mix of housing types. Single-family housing has, and will continue to have, strong market demand. Higher density townhouses and multi-family units are, however, gaining an increasing proportion of the market share. The range of permissible residential densities in TODs can accommodate all of these household needs. Providing a mix of housing types will also result in more "cosmopolitan" communities.

Guideline 5B:

RESIDENTIAL DENSITIES

Residential densities within Neighborhood TODs must be a minimum of 12 units per net acre and a minimum average of at least 18 units per net acre. Residential densities within Urban TODs must be a minimum of 18 units per net acre and have a minimum average of at least 25 units per net acre. Maximum densities should be set by community plans.

Discussion:

The range of permissible TOD densities is designed to encourage transit ridership, as well as provide a variety of housing types, as shown in the following table:

	Minimum Density	Minimum Average	Maximum Density
Neighborhood TOD	12 du/net ac	18 du/ac	To be determined by community plans
Urban TOD	18 du/net ac	25 du/ac	

Note: Residential densities in TODs will be measured in net densities.

Single-family ownership patterns with ancillary units are feasible between 12 and 17 units per net acre. Ancillary units will be calculated as 1 unit per lot. For example, a 4,500 s.f. or smaller lots will create densities of 16 units/net acre or greater if developed with an ancillary unit. Townhouses can be provided between 18 and 29 units per acre. Smaller attached units, with up to five stories, can be provided at higher densities of up to 70 du/net acre. Actual densities should allow TOD development to strike a balance between emphasizing the importance of development around transit stops and blending in with existing surrounding neighborhoods. Typical average densities in Neighborhood TODs should be between 20 and 30 du/net acre and in Urban TODs between 25 and 45 du/net acre.

Justification:

The required density range offers flexibility to respond to changing market conditions and encourage a mix of housing types. The range of permissible residential densities meets this requirement at a minimum and allows higher densities which provide a variety of housing opportunities for the increasingly diverse household composition of the San Diego region.

Guideline 5C:

ANCILLARY UNITS

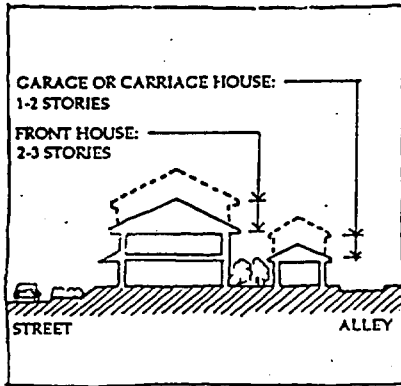

Ancillary 'granny' units are encouraged in TODs and in Secondary Areas as a means of providing multifamily densities with a single family character.

Discussion:

Ancillary units, or second units, create affordable rental and family housing while providing the character and quality of single family neighborhoods. They should be developed in areas that are suitable for multi-family densities, where a mix of ownership and rental housing is desired. Ancillary units are not intended as a strategy for intensifying densities in established single-family neighborhoods.

Ancillary units can also serve to offset housing costs for the primary unit, provide needed space for a teenager or elderly family member, or act as transitional single family housing. Ancillary units can be provided in TOD and Secondary residential areas, either as part of the primary home or above a garage. At least one off-street parking space is required for the ancillary unit.

Ancillary units will be calculated as an additional unit per lot in TODs and in Secondary Areas. The following table illustrates the density received when ancillary units are provided.

Location	Lot Size	Density Without Second Unit	Density With Second Unit
TOD	33' x 100'	11 u/ac	22 u/ac
TOD	40' x 100'	9 u/ac	18 u/ac
TOD	45' x 100'	8 u/ac	16 u/ac
Secondary Area	50' x 100'	7 u/ac	14 u/ac
Secondary Area	65' x 100'	5 u/ac	10 u/ac

Justification:

Ancillary units are strongly encouraged in TODs to provide rental housing opportunities and to meet the increasing demand in the San Diego area for a variety of housing types. They also increase the density of an area without changing the pattern of single lot private-ownership which has a very strong market. As a source of affordable rental housing they avoid the "institutional" character of many apartment projects and the segregation of low income groups. Ancillary units are common in neighborhoods such as University Heights and Sherman Heights, and in parts of North Park, San Ysidro, Ocean Beach and Pacific Beach.

Guideline 5D:

**RESIDENTIAL BUILDING
SETBACKS**

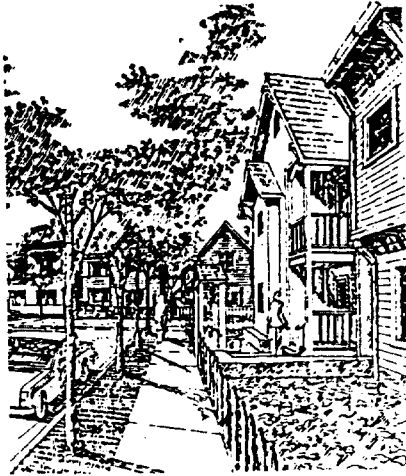

Residential building setbacks from public streets should be minimized, while maintaining privacy. Minimum and maximum front setbacks should be established that reflect the desired character of an area and ensure that residences address streets and sidewalks.

Discussion:

In most new residential areas, building setbacks should be between 10 and 15 feet from the property line; in Redevelopable and Urbanizing areas, residential setbacks should complement the setback of surrounding buildings. Where units are set above finished grade, such as over depressed parking garages, the setback may be reduced. If housing occurs over first floor commercial space, no setback is required. Porches, bays and balconies should be allowed to project into these setbacks to contribute to a street's human-scale and activity. If residential units are set back from the street, the setback area should be landscaped.

Justification:

In residential areas, minimal front yard setbacks encourage recessed garages and dedicate a greater portion of the lot to private back yards. Reduced setbacks also create safer and more active streets. Residents can more easily watch over the street and know their neighbors.

Guideline 5E:

**RESIDENTIAL
BUILDING FACADES**



Building facades should be varied and articulated to provide visual interest to pedestrians. Frequent building entries and windows should face the street. Front porches, bays, and balconies are encouraged. In no case shall a facade of a building consist of an unarticulated blank wall or an unbroken series of garage doors.

Discussion:

Varied and human-scaled building facades are key to making a place "pedestrian-oriented." Building designs should provide a high level of visual interest, without creating a chaotic image. Residences should include design elements that enhance the streetscape and address the street. Facades should vary from one building to the next to avoid a monotonous streetscape.

Justification:

Varied and human-scaled facades enhance pedestrians' visual interest and sense of security along streets. Streets with monotonous and unarticulated building frontages make walking less appealing and are not conducive to pedestrian activity. Quality construction and materials further contribute to the neighborhood as a pleasant place.

Guideline 5F:

**RESIDENTIAL
BUILDING ENTRIES**

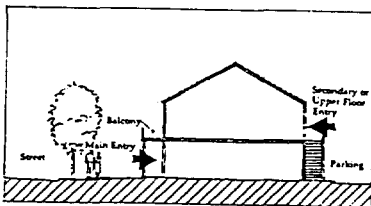

In all cases, primary ground floor residential building entrances must orient to streets, not to interior blocks or parking lots. Secondary and upper floor entries from the interior of a block are acceptable.

Discussion:

In residential areas, the front door and guest entry must orient to the street. Private backdoor entries can provide access from alleys, garages, and parking lots. Ancillary units and upper floor units in multi-family or apartment complexes may be accessed by rear entries. Ramps for individuals with mobility limitations should be integrated into the facade design.

Justification:

As with commercial uses, residential entries should face the street to encourage public activity in the public realm and to welcome visitors from the on-street guest parking.

Guideline 5G:

RESIDENTIAL GARAGES

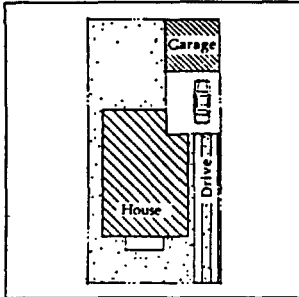

Side Drive (Detached)

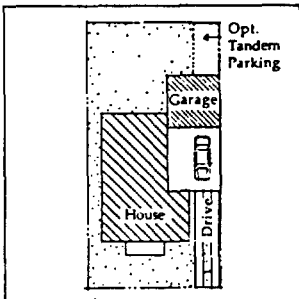

Side Drive (Attached)

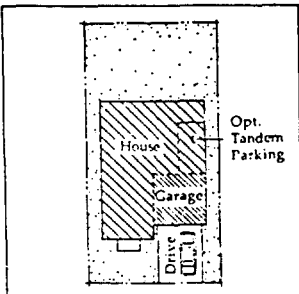

Modified Front Garage

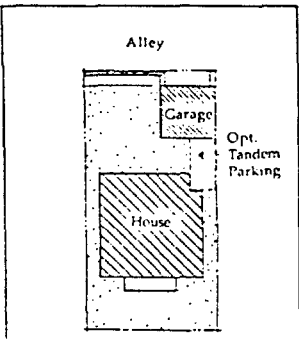

Alley (Attached or Detached)

Residential garages should be configured to reduce the visual impact of the auto and to line the street with active, visually interesting features. The garage should be set back behind the front facade of the residential building. Garages may be sited in several acceptable ways: in the rear and accessed from an alley, in the rear and accessed from a side drive, or garages may be sited to the side, but should be recessed behind architectural features and the front facade by at least 5 feet.

Discussion:

Garages must be sited away from the street behind or below residential buildings. Where the garage is below residences, it should be depressed so that the first floor of residences is not more than 2 1/2 feet above finished grade. Tandem parking is permitted in garages.

Justification:

An active, pleasant and safe pedestrian environment is created along streets when residences face the street directly. By setting garages away from the street, more active living areas can overlook the street, thereby enlivening the street and allowing residents to keep a watchful eye on playing children and neighborhood activity. This configuration also creates a more human-scaled and less monotonous environment by minimizing the visual impact of large, blank garage doors and by enclosing the street with a variety of architectural elements, such as windows, bays and porches.

6. Secondary Areas

Guideline 6A:

TYPE AND PROXIMITY OF USES

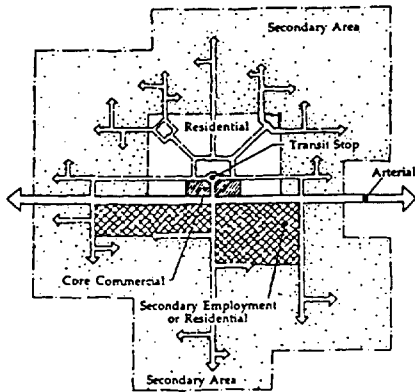

Secondary Areas may have lower density housing, public schools, and community parks. Those parts of Secondary Areas that are in close proximity to the TOD core commercial area may have intensive employment-generating uses and park and ride lots to complement the TOD.

Discussion:

Secondary Areas should contain uses that support the TOD, but do not compete with the retail, professional office, service commercial, and public uses in the TOD's core commercial area. In most cases, Secondary Areas will be primarily comprised of low density single-family neighborhoods. In limited cases, large single-use office or light industrial uses with sufficient employment density to support transit, could be located across the arterial from the TOD core commercial area. Uses such as public schools and community parks, which provide services to TOD residents, should be located close to the TOD.

Employment-generating uses that have intensities which support transit may be allowed within one mile of the TOD core (preferably directly across the street from the core commercial area), if integrated into the transit system. These uses must generate an equal or greater number of persons per acre as generated by residential uses at a density of 7 dwelling units per net acre (+/- 16 residents/acre). For example, a typical office development will generate between 30 and 40 employees/acre, while a standard industrial development only generate 10 to 15 employees per acre and would not be considered as transit-supportive. Although Secondary Area uses across the arterial will produce less pedestrian traffic than adjacent areas, their street system and proximity will provide some non-auto opportunities.

Justification:

Secondary Areas provide an important support base for both the core commercial area and the ridership of the bicycle and transit system. They also provide opportunities for lower density residential development. If properly designed, Secondary Areas can reinforce the viability of the TOD and provide sites for uses that some TOD residents will need. Secondary Areas, however, must not allow competing retail uses because this will significantly detract from the TOD's ability to draw transit and retail patrons.

Guideline 6B:

**RESIDENTIAL DENSITIES
IN SECONDARY AREAS**

The minimum average residential density within Secondary Areas in New Growth areas shall be 7 units per net acre. Ancillary units will be counted as an additional unit per lot.

Discussion:

A variety of low density housing types and densities should be provided in Secondary Areas such that a minimum average density of 7 units per net acre is maintained.

To help meet this minimum average density standard, higher density half-plexes and duplexes could be located on street corners.

Justification:

Secondary Areas provide opportunities for low density housing types that cannot be accommodated in TODs and are essential to ensuring that communities are diverse. Secondary Areas also provide housing for the "move up" market.

Guideline 6C:

**BIKEWAYS IN
SECONDARY AREAS**

The primary roadway system in Secondary Areas must provide strong bicycle connections to the TOD core commercial area and transit stop.

Discussion:

Arterials and selected collector roadways in Secondary Areas must provide safe separated or marked bicycle lanes allowing quick travel to the transit stop. Secondary Area bicycle paths should connect with the TOD bicycle system.

Justification:

Bicycles are the most likely mode of travel for Secondary Area residents who are apt to use public transit. Strong bicycle connections which follow the shortest possible routes will provide additional encouragement for Secondary Area residents to use transit.

Guideline 6D:

**PUBLIC AMENITIES
IN SECONDARY AREAS**

Day care, neighborhood parks, schools, small convenience stores, and public recreation facilities may be provided to serve Secondary Areas.

Discussion:

Public amenities should be provided in central locations of Secondary Areas. These facilities should be sized to help accommodate the needs of the Secondary Area population.

Justification:

Secondary Areas must have sufficient public recreation amenities and public services. These facilities should be easily accessible to all Secondary Area residents.

7. Open Space, Parks and Plazas

Guideline 7A:

LOCATION OF PARKS AND PLAZAS



Parks and plazas should be the focus of developments and should be placed next to public streets, residential areas, and retail uses. Parks and plazas should not be formed from residual areas, used as buffers to surrounding developments, or used to separate buildings from streets. Private open space amenities may not count toward meeting the public use requirement.

Discussion:

Public parks and plazas are fundamental features of livable and enjoyable higher density communities. Park and plaza sites should reinforce retail and residential areas by creating "town squares" suitable for informal gatherings or public events. Appropriate sites are centrally located and adjacent to streets and shopping areas, such as Pantoja Park in Centre City. In many communities, parks and plazas are located on sites that are not suitable for other types of uses, such as under freeways, on oddly shaped parcels at the edge of a development, or within private residential or office complexes. These sites are also not suitable for public parks and plazas and rarely function effectively as such.

Justification:

Parks and plazas in TODs act as neighborhood meeting places, recreational activity centers, child care facilities, and lunch time picnic spots. Because their function is primarily "public activity," they are most appropriately located central to residential or core areas.

Guideline 7B:

**PARK AND
PLAZA DESIGN**

Public parks and plazas should be designed for both active and passive uses. They should reflect and reinforce the character of the surrounding area and accommodate the anticipated intensity of use. Private open space amenities may not count towards TOD park acreage requirements.

Discussion:

Various types of parks and plazas can be designed for TODs and Secondary Areas to establish an identity or character for each neighborhood. For example, plazas in commercial core areas may be most appropriately designed with finished hardscape materials such as stone or brick, and include fountains and seating areas; parks in residential areas could be developed with grassy fields, play equipment, and sports facilities. Parks should not be situated on oddly shaped parcels or within private areas.

Justification:

The design of parks and plazas should be appropriate to their setting, location, and use. Because parks and plazas will be focal points of TOD and Secondary Area activity, special consideration should be given to making these public spaces not only functionally appropriate, but consistent with the character and density of the surrounding area. Sensitive integration of public spaces is also critical to public acceptances and commercial success; Seaport Village is an example of successful use of this technique.

Guideline 7C:

**PARK AND PLAZA
LANDSCAPING**

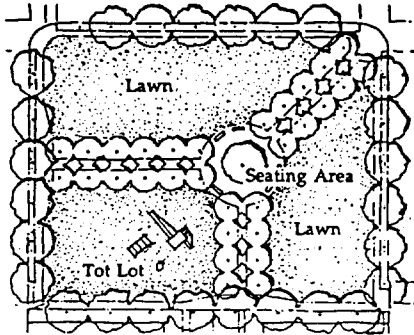

Parks and plazas should provide adequate shading for comfortable mid-day summer use and sunny areas for winter use. Landscape design must respect vistas created by streets.

Discussion:

Park and plaza landscaping should provide trees and plants that make comfortable, relaxing environments. The amount and location of such landscaping should be appropriate to and complement the character and design of the space. Landscaping should allow comfortable use in both summer and winter months.

Because parks and plazas form the spine of urban public spaces, views and linkages to streets and other public spaces and buildings must be respected and reinforced through design elements. For example, paths should align with important viewpoints; trees should not block views of significant public monuments or buildings; and perimeter landscaping should allow views into a park.

Justification:

Public park and plaza landscaping should create places that are comfortable, safe, and linked with the overall network of public spaces. Flexible landscaping guidelines should be permitted so that a variety of spaces are created which reflect the role and character of the place.

Guideline 7D:

**OPEN SPACE RESOURCE
PROTECTION**

Major creeks, riparian habitat, slopes, and other sensitive environmental features should be conserved as open space amenities and incorporated into the design of TODs. Fencing and piping of creeks should be avoided and channelization improvements should be minimized.

Discussion:

Open space resources should be incorporated into the design of TOD and Secondary Areas, in a manner consistent with City standards and CEQA. These resources should be treated as key amenities, rather than as edges to developments. Public access should be permitted, while important natural features and sensitive habitats are preserved. In Mission Valley there is an opportunity to create TODs centered around planned light rail transit stations and oriented to the San Diego River. In New Growth Areas, there is an opportunity for open spaces to shape and enhance neighborhoods, to provide a scenic resource from roads, as well as to serve as wildlife corridors.

Bicycle paths can often be constructed with linear parks, thus serving a dual function of allowing public access to open space and providing non motorized transportation to activity centers along the edges of linear parks.

Justification:

Natural features provide visual relief and a natural character for the growth area. These areas can also include trails and small picnic areas that serve TOD and Secondary Areas. Sensitive site planning should be encouraged so that natural habitats are protected and natural features become an integral part of the community.

Guideline 7E:

COMMUNITY BUILDINGS

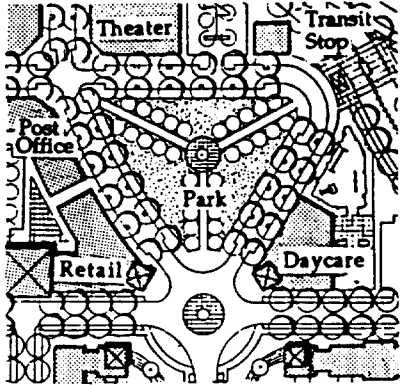

Civic services, such as community buildings, recreation centers, post offices, libraries and day care, should be placed in central locations as highly-visible focal points.

Discussion:

Day care, libraries, and police, fire and postal stations should be located in retail areas or in small parks or plazas located adjacent to retail businesses and offices. Day care should also be located in association with major neighborhood parks in Secondary Areas to contribute to the sense of identity of these single family neighborhoods.

Major building entries should face public streets and be articulated architecturally. The building and architectural features should be sited to take advantage of vistas along streets to visually connect these civic buildings with their surrounding neighborhood. Major public buildings should have a civic presence enhanced by their height, mass and materials. Construction and materials should convey a sense of permanence and importance.

Justification:

Community buildings can enhance the emerging identity of the growth area, as well as reinforce connections with the past in older neighborhoods. Civic structures will contribute to the level of activity in TOD centers and encourage walking and transit use by patrons and employees. Community buildings associated with parks can contribute to the identifying aspects of Secondary Area neighborhoods as well. These parks and community buildings will help to differentiate one neighborhood from the next, and help to create a node of activity apart from the TOD centers. The architectural quality of community buildings, such as the Linda Vista library, can elevate the prominence and civic importance of these buildings.

Guideline 7F:

**SCHOOLS AND
COMMUNITY PARKS**

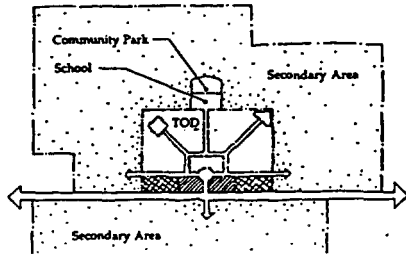

If needed, school sites and community parks should be located at the edges of TODs within Secondary Areas. Strong pedestrian and bike links should connect these sites with the commercial and transit core.

Discussion:

While schools and community parks are not necessary uses in the TOD, they may be needed to serve the population of the TOD and the Secondary Area. Schools and community parks should be located within convenient walking distance (1/2 mile) of the TOD, in the Secondary Area. Pedestrian paths and bikeways should follow the shortest route to the commercial and transit core.

Justification:

Land within TODs should maximize transit-oriented uses. Schools and community parks may be necessary public facilities for TOD residents, but can be located at the edge of TODs without detracting from the function of the TOD.

Guideline 7G:

DAY CARE

Sites for pre-school day care facilities should be provided in all TODs and throughout Secondary Areas.

Discussion:

Day care facilities should be convenient and accessible to both TOD residents and employees. Sites should be located within residential neighborhoods, adjacent to parks, core commercial areas, and office buildings. The precise parcel size, and size of the facility should be determined by the developer in conjunction with appropriate local agencies. Day care facilities for school-age should be located at school sites to meet the needs of each school's students.

Justification:

Household demographics in the San Diego region are in the process of changing and becoming more diverse. More households are and will be headed by single or double-income parents, creating a strong demand for child care services. A basic objective of the TOD concept is to provide housing opportunities for a variety of household types, and day care facilities are increasingly a necessary daily part of residents' lives. Additionally, many parents now lengthen early morning and evening auto trips by driving to a child care facility before continuing on to work. Locating child care facilities in TODs will not only provide a necessary service, but will allow parents to make the day care trip part of their commute trip, thus reducing vehicle-miles traveled.

8. Street and Circulation System

Guideline 8A:

ARTERIAL STREETS AND THOROUGHFARES

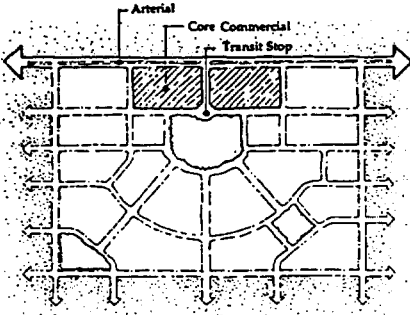

Arterial streets and thoroughfares should allow efficient conveyance of through traffic and must not pass through TODs. Portions of Secondary Areas may be located across an arterial from a TOD.

Discussion:

The regional traffic circulation system is dependent upon an efficient and smooth-flowing network of arterial and thoroughfare streets. Traffic on arterial streets should not be slowed by activity in the TOD. TOD sites should be selected such that arterial and thoroughfare streets are located at the TOD's periphery; not through the center of the TOD.

Arterials may be located between the TOD and the Secondary Area. The lower intensity uses in the Secondary Area can benefit from proximity to the core commercial area, by permitting workers and bicyclists access to the TOD. Convenient pedestrian and bike crossings should be provided wherever cross-arterial connections are made, consistent with State guidelines contained in the Caltrans Traffic Manual. At these major intersections, it is the City's policy to provide on-demand pedestrian-activated signals. Under- and over-crossings are expensive and generally unused; they are discouraged, unless absolutely necessary in already developed areas.

Justification:

In many areas, the main spine of the transit system will follow arterial streets and major thoroughfares. These four- to six- lane streets are barriers to pedestrian activity and thus should not be the focal point for the TOD. Rather, large traffic carrying streets should be located at the perimeter of a TOD or at the junction of two adjacent TODs.

Guideline 8D:

COMMERCIAL STREETS



Commercial streets located in the center of Core Commercial areas should be designed to accommodate pedestrians, slow traffic, provide on-street parking and create a pleasant shopping environment.

Discussion:

Commercial streets should have two travel lanes and on-street parking in order to create an intimate shopping environment that maintains drive-by visibility to stores. Shops should front onto commercial streets with minimal setbacks. Wider sidewalks, street trees, awnings and arcades should be used to accommodate this active, pedestrian environment. Curbs and landscaping should be configured to allow passage of street cleaning equipment.

Justification:

Commercial streets can create a pleasant and active commercial spine within Core Commercial areas. Slow traffic and comfortable walking environments will encourage walking for many shopping trips, thereby reducing reliance of the automobile and creating an active "main street."

Guideline 8E:

LOCAL STREETS



Local streets should have travel and parking lanes sufficiently narrow to slow traffic and allow trees to form a pleasing canopy over the street, while providing for adequate access for automobiles, and emergency and service vehicles.

Discussion:

Local streets should be designed to serve low volumes of traffic through a pedestrian-oriented environment. Travel and parking lanes should only be wide enough to allow two vehicles to slowly pass each other. Emergency and service vehicles would be accommodated by using both travel lanes. Street trees should be provided to enhance the quality of the neighborhood and provide relief from summer heat.

Justification:

Local streets are the public open space in which children often play and around which neighbors interact. Vehicular movement should be controlled and provided for within this context.

Guideline 8F:

ALLEYS



Where possible, alleys should be used to serve residential and commercial developments within TODs, and for lots facing onto parks and collector streets in Secondary Areas.

Discussion:

Alleys are a traditional accessway in San Diego in older neighborhoods such as North Park, Ocean Beach and Hillcrest. Alleys provide relief to the street system and a secondary access to individual parcels. Alley-accessed garages relieve the street side of the house from being dominated by garage doors and cramped by curb cuts. Design of alleys should provide sufficient lighting to ensure night-time safety; units facing onto alleys should be provided adequate parking. Where alleys intersect with streets, adequate sight distances and building setbacks should be provided.

Justification:

In areas where walking is to be encouraged, streets lined with garages are undesirable. Alleys provide an opportunity to put the garage to the rear allowing the more 'social' aspects of the home to front the street. Streets lined with porches, entries and living spaces are safer because of this natural surveillance. Alleys in commercial areas place service vehicle access and parking away from the street and sidewalks, affording a more interesting and comfortable streetscape.

Guideline 8G:

STREET VISTAS

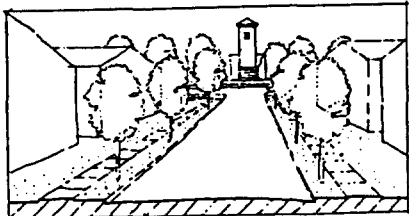

Where possible, streets within TODs should frame vistas of the core area, public buildings, parks and natural features.

Discussion:

Streets should be designed so they terminate at important buildings and places. This will establish a series of pedestrian "landmarks," to help make the TOD spatially memorable, and allow pedestrians to feel the context of their community. Straight streets, in particular, allow clear views to landmarks and are encouraged. In areas with steep slopes, the street system should work with the natural topography to accent important landmarks.

Justification:

Visible landmarks help orient pedestrians and make walking routes interesting and memorable. Straight streets make destinations more accessible by making them visible; if a destination is visible, a person is more likely to walk to it.

Guideline 8H:

STREET TREES

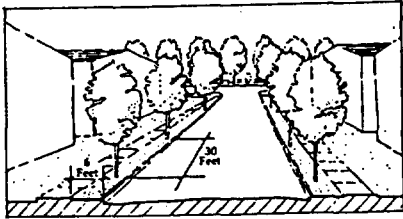

Shade trees are required along all streets in New Growth Areas and should be strongly encouraged in Redevelopable and Urbanizing areas. Street trees should be spaced no further than 30 feet on center in planter strips located between curbs and sidewalks. Tree species and planting techniques should be selected to create a unified image for the street, provide an effective canopy, avoid sidewalk damage, and minimize water consumption.

Discussion:

Many streets are identified and remembered by their street trees. TOD and Secondary Area streets should be lined with a limited selection of trees to give them a unified and distinct image. Adequate sight distances must be maintained, according to the City's Street Design Manual, in order to ensure safety. Within TODs, trees should be placed in a planter strip between the street and sidewalk. In Secondary Areas that do not have planter strips, the trees should be kept close to the sidewalk to provide shade and should be aligned to visually frame the street. In all cases, trees should be trimmed regularly to accommodate buses and service vehicles. Tree maintenance should be ensured through the creation of Landscape Maintenance Districts or other means.

Justification:

Shade for the comfort of the pedestrian is key to creating a viable walking environment. Street trees help reduce heat build-up from large asphalt areas and create a cooler micro-climate. Trees also provide habitat for local birds and help create a beautiful community.

Guideline 8I:

ON-STREET PARKING

On-street parking is encouraged on all TOD and Secondary Area streets, except arterials. In Redevelopable and Urbanizing sites, existing streets should be modified, as feasible, to provide on-street parking and landscaping.

Discussion:

Streetside parking is critical to keeping the focus of a community on the street, rather than on the interior of lots. On-street parking helps to create street activity, as well as provide functional spaces. It supports orienting building entries to the street by providing convenient access for guests and patrons. Parallel parking should be used most often, however, angled on-street parking is encouraged along shopping streets within core commercial areas, where slow drive-by traffic is desired. To maintain travel speeds and emergency vehicle access, on-street parking should not be permitted on arterials.

On-street parking on local streets can also be compatible with bicycle travel, provided that auto speeds are slow enough (+/-15 to 20 miles per hour) to allow bikers to travel in the street at the same speed as the cars. However, on selected high-volume connector streets where on-street parking is to be retained, it is desirable to include sufficient room within the roadway for installation of bike lanes.

Justification:

On-street parking helps to "civilize" the street for pedestrians by creating a buffer between moving cars and the sidewalk. The additional parking helps to replace areas devoted to large off-street surface parking lots and places the parking near the desired street-side building entries. On-street parking tends to slow the flow of through traffic. This helps to develop a pedestrian environment where walking is desired, but conflicts with the role of arterial streets to move traffic safely and smoothly through the community.

Guideline 8J:

**INTERSECTION
DESIGN**

Intersections within TODs and Secondary Areas should be designed to facilitate both pedestrian and vehicular movement. Intersection dimensions should be minimized while providing adequate levels of service.

Discussion:

Since the TOD street is conceived as more than a conduit for cars, street and intersection widths should be kept to a minimum. Intersections should be designed to slow traffic and to reduce pedestrian crossing distances. The practice of prohibiting pedestrian crossings between certain corners of intersections to facilitate motor vehicle traffic flow should be discouraged. Unless absolutely necessary for facilitating safety, right and left turn lanes at intersections should be avoided.

Justification:

A street system should balance the needs and viability of the pedestrian, as well as the car. Reduced auto speeds improve pedestrian accessibility and safety, and can continue to accommodate safe vehicular movement. Unless absolutely necessary, additional turning lanes at intersections should be avoided to minimize pedestrian crossing dimensions.

9. Pedestrian and Bicycle System

Guideline 9A:

PEDESTRIAN ROUTES



Pedestrian routes should be located along or visible from streets and linked to local destinations. Routes through parking lots or at the rear of residential developments should be avoided. Primary pedestrian routes and bikeways should be bordered by residential fronts (rather than back yards), public parks, plazas, or commercial uses.

Discussion:

The pedestrian and bicycle system must provide clear, comfortable, and direct access to the core commercial area and the transit stop. Too often private pedestrian paths have been separated from streets, giving a confusing message to pedestrians as to the primary orientation of buildings and creating paths which can be dangerous because they lack adequate surveillance and auto access. Where possible, the primary pedestrian path system should coincide with the street system. Paths through parking lots and away from streets should be avoided. Alternate routes around parks should be provided for night use.

Safe pedestrian crossings across arterials should be provided where major pedestrian movement is anticipated, such as along greenways and across from core commercial areas. On-demand pedestrian signals should be provided during off-peak hours in these locations. Under- and over-crossings are expensive and generally unused; they are discouraged, unless absolutely necessary in already developed areas.

Justification:

Up to 75 percent of all household trips are non-job related¹. Many of these non-commute trips can be captured within the TOD or within a short transit connection. Combining retail uses with a transit stop provides the opportunity for people to accomplish several tasks with one trip. Such combinations reinforce and expand transit convenience and utilization.

The comfort of the pedestrian is dependent on a sense of security and familiarity. Interruptions in the path and inconvenient walking or biking routes discourage pedestrian or bicycle travel for these types of trips. Paths which are lined with activities or occupants are safer. Additionally, paths to the rear of housing can present a security risk to its adjacent neighbors.

¹Professor Deakin, University of California, Berkeley

Guideline 9B:

**CONNECTIONS TO THE
CORE AREA AND
TRANSIT STOP**

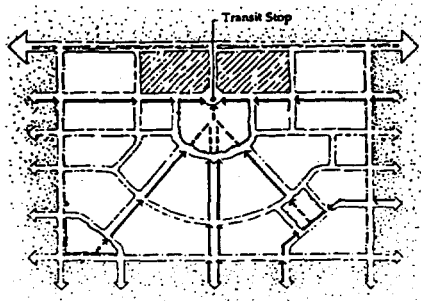

The pedestrian and bicycle system must provide clear, comfortable, and direct access to the core commercial area and the transit stop.

Discussion:

Although the street and sidewalk system will accommodate many destinations within TODs and Secondary Areas, the primary destination will be the commercial core and transit stop. Direct paths to the transit stop should be lined with activities and be shaded. The configuration of parking, shopping and pedestrian routes should reinforce access to transit.

Justification:

Up to 75 percent of all household trips are non-job related. Many of these non-commute trips can be captured within the TOD or within a short transit connection. Combining retail uses with a transit stop provides the opportunity for people to accomplish several tasks with one trip. Interruptions in the path and inconvenient walking routes discourage pedestrian travel for these types of trips. Pedestrian access is critical to the displacement of auto trips within the TOD and to encourage as much transit use as possible.

Guideline 9C:

**ARTERIAL CROSSINGS
AND PEDESTRIAN
BRIDGES**

Crosswalks should be provided at all signalized arterial intersections. Undercrossings or bridges designed for pedestrians and bicyclists are discouraged, unless necessary in already developed areas to solve critical access problems.

Discussion:

Crosswalks at signalized intersections should provide easy and safe pedestrian and bicycle movement across arterials or to difficult to reach transit stops. On-demand signals can be located at strategic intersections, such as where a connection would be made to a transit stop or core commercial area, which could be activated during off-peak commute hours. Underpasses or pedestrian bridges are discouraged because they are expensive and are generally long, circuitous routes that are often unused. However, in some limited cases, where existing development patterns prevent any other convenient street crossings, an under or over pass may be appropriate; direct stairs in addition to handicapped access ramps, could be provided to shorten walking distances.

Justification:

Pedestrians and bicyclists must be permitted to move easily and safely across arterials if an environment that is not reliant on the automobile is to be created. Intersections should be designed to provide direct pedestrian and bicycle connections between core commercial areas, employment areas, parks, schools, residential areas and other destinations.

Guideline 9D:

SIDEWALKS

Sidewalks are required on all streets in TODs and Secondary Areas. Sidewalks should provide an unobstructed path at least 5 feet wide.

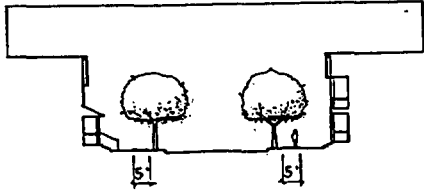

Discussion:

A 5 feet clear corridor is a minimum width for two people to walk abreast comfortably. Larger sidewalk dimensions are desirable in the core commercial area where pedestrian activity will be greatest and where outdoor seating is encouraged. Generally, sidewalks should be between 5 and 10 feet wide in TODs; width should be determined based on location, context and role within the TOD.

Justification:

Comfortable sidewalks reinforce pedestrian environments within TODs and Secondary Areas. The comfort and convenience of the pedestrian trip will reduce internal auto trips and reinforce the efficiency of the transit system by creating destinations which are attainable without a car and origins which do not depend solely on park-and-ride mode transfers.

Guideline 9E:

BIKEWAYS

A coordinated system of bikeways should be provided in conjunction with TODs or a series of TODs. Important destinations, such as core commercial areas, transit stops, employment centers, schools and other community facilities, should be linked by these bike routes.

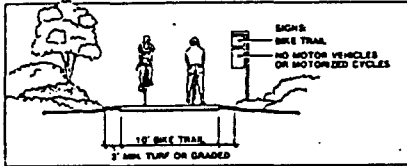

Class I

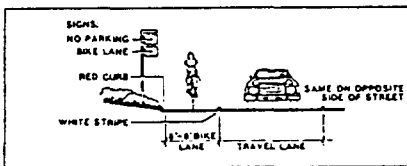

Class II

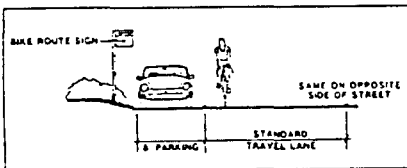

Class III

Discussion:

Selected routes to the transit stop should provide marked or separated bikeways connecting with the Secondary Areas and other key destinations. Designated bike lanes (class II) should be provided on selected connector streets and a limited number of arterial streets which converge upon the commercial and transit center. Bicycle routes are encouraged on small residential streets, but designated or marked bike lanes are not required (class III). Separated bike paths should also be provided along greenways and through open space corridors (class I).

Bikeways should be well identified by bikeway signs that indicate the beginning, end and route of the bikeway, as well as clear destination signs that direct riders to key activity centers, such as shopping areas, transit stops, recreation facilities, and schools, and bike parking facilities.

Justification:

Biking can be a major alternative to the auto for local trips, trips to the transit stop or trips to work. Separated or marked bike lanes on several primary routes to the core area will support this alternative, as will the bike paths along greenways. On smaller streets, bikes sharing the travel lane will help slow cars to speeds more appropriate for residential streets.

Guideline 9F:

BIKE PARKING



Bicycle parking facilities must be provided throughout core commercial areas, in office developments and at transit stops, schools and parks.

Discussion:

Bicycle parking facilities include both bike racks and bike lockers. Bike racks must be provided at shopping, school, and recreational destinations in TODs and Secondary Areas. Bike racks and lockers must be provided at all office/employment uses and at trolley stops and main bus stops. Signs indicating the location of bike parking facilities must be clearly posted. Bike parking may be shared between uses, but should be centrally located, easily accessible to building entries, closer to the building than auto parking areas, and visible from streets or parking lots. These facilities should not block pedestrian routes.

Justification:

Facilities must be provided to encourage bike travel to and within the TOD. Bike racks and lockers located at destinations, such as the core commercial area and office developments, will make it more convenient to bike to work or shopping.

10. Transit System

Guideline 10A:

LOCATION OF TRANSIT STOPS

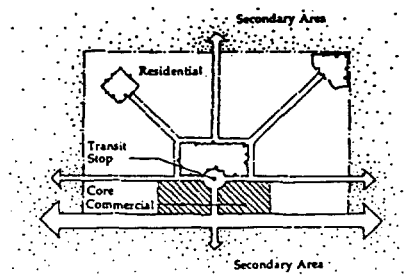

Transit stops should, whenever possible, be centrally located within a TOD and adjacent to the core commercial area. Commercial uses should be directly accessible from the transit stop. Additional feeder bus stops may be located in Secondary Areas along connector streets and adjacent to parks and public facilities.

Discussion:

Transit stops should provide pleasant and convenient access to TOD residential and core commercial areas. TOD sites should provide the greatest possible access to, and frontage on, the transit stop. This can be achieved by selecting a site which surrounds the transit stop.

If the TOD is located next to an arterial, the transit stop should be centrally located, away from the arterial and the express bus or feeder bus routes should loop into the TOD to the transit stop. If the TOD is to be served by trolley, the trolley line should either feed directly into the heart of the TOD and its core commercial area, or the stop may be located along the arterial street and the core commercial area should also be located so that at least a portion of the retail area is along the arterial. TODs along existing high frequency bus lines, such as those along El Cajon and University, should respond to the linear nature of the transit line by forming a series of transit-oriented nodes, rather than perpetuating current strip commercial patterns. Transit stops would be located along these major streets, with TOD core commercial areas forming a pedestrian-orienting frontage and TOD residential areas located on the blocks behind the major streets.

Justification:

Accessibility is the key to successful capture of transit ridership. A centrally located transit stop is closest to the greatest number of TOD residents and employees.

Guideline 10B:

**TRANSIT STOP
FACILITIES**

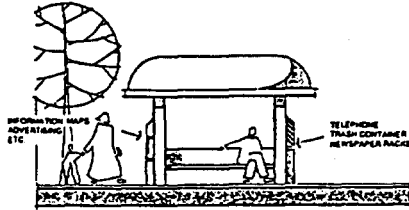

At a minimum, TOD transit stops shall provide shelter for pedestrians, convenient passenger loading zones, telephones, adequate lighting, and secure bike storage.

Discussion:

Comfortable waiting areas, appropriate for year-round weather conditions, must be provided at all transit stops. Shelters should be designed with passenger safety and comfort in mind, and should be easily recognizable, yet blend with the architecture of the transit station and/or surrounding buildings. Passenger loading zones should be located close to the stop and provide for handicapped access, but should not interfere with the transit stop operations. Secure and safe bicycle storage areas, such as bike lockers, bike racks, or monitored "bike checks," must also be provided, as well as convenient telephones and adequate lighting. Retail services should also be integrated with transit stops. At a minimum, developers will be required to set aside sites for transit stops.

Justification:

TOD transit stops are apt to be used a greater portion of the year and by people using a variety of modes to get to them, than are stops in typical auto-oriented developments. Consequently, transit stop facilities should accommodate and encourage active use by providing year-round shelters, convenient loading zones, and secure bike storage.

Guideline 8B:

STREET DIMENSIONS

TOD and Secondary Area lane widths, design speeds, and number of travel lanes should be minimized without compromising auto safety, on-street parking or bike access.

Discussion:

In TODs and Secondary Areas, local and connector streets should be designed or redesigned such that lane widths, design speeds and number of travel lanes are kept to a minimum, without compromising auto safety, in order to provide space for landscaping, bicycle access and on-street parking. This may require posting signs or providing road humps or other appropriate geometric design features at the entrance to TOD neighborhoods to alert drivers of new street standards.

Justification:

Slowing auto traffic in the TOD is desired to create a safer, more comfortable pedestrian and bicycling environment. Minimum street dimensions are intended to make streets more intimate in scale while providing for municipal service vehicle access and maintaining auto safety. Smaller street sections will reduce street crossing dimensions and result in cost savings which can in turn be allocated for pedestrian amenities. Slower design speeds will help keep traffic in residential areas moving slowly and safely.

Guideline 8C:

CONNECTOR STREETS

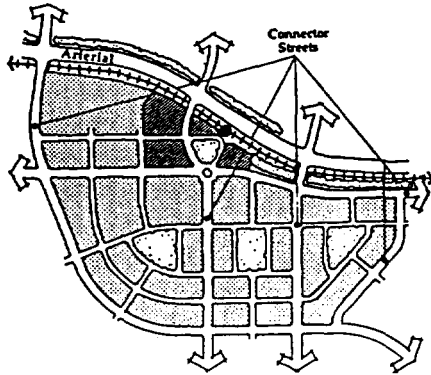

Connector Streets provide frequent, alternative routes serving neighborhoods

Connector streets should provide connections within TODs and Secondary Areas to Core Commercial areas, schools and community parks without requiring the use of arterials. They should be designed to carry moderate levels of local traffic smoothly, in a way that is compatible with bicycle and foot traffic. A network of connectors should provide many, frequent alternative paths through neighborhoods. The connector network should not provide an efficient through-route alternative to arterials.

Discussion:

Connector streets should form a network of routes that provide alternative paths through neighborhoods and to major destinations, such as Core Commercial areas, schools and parks. "T" intersections and "dog leg" alignments should be used to reduce through traffic and reduce speeds; use of these features should be reviewed by City staff for potential safety concerns. The precise alignment of connectors will be determined as individual projects are designed, but should provide a network of routes that provide alternative paths through neighborhoods and to major destinations such as Core Commercial areas, school and community parks. The width of connector streets should be minimized, especially where traffic volumes are not high.

On-street parking should be provided. Connectors should contain Class III bikeways, where bicyclists share the travel lane. Driveway cuts should be minimized and alley access to rear garages is encouraged to minimize potential conflicts among autos and bicyclists, and for the convenience of residents along connectors. Connectors should be aligned along the edge of parks and open space to enhance the aesthetic character of the street and sidewalks.

Justification:

Connectors are intended to carry moderate levels of local traffic from neighborhoods to arterials and major destinations. Their design and alignment should balance efficient vehicular travel with the safety and livability of residential areas. Minimizing the width of travel lanes and using on-street parking, "dog legs" and "T" intersections, connectors will slow traffic and offer a pleasing streetscape, while providing smooth vehicular movement. Providing a connector network with frequent, alternative paths will distribute traffic volumes over more routes and permit all connectors to have residences that face onto them and provide an environment oriented towards pedestrians and bicyclists.

Guideline 10C:

**STREET CROSSINGS TO
TRANSIT STOPS**

Streets must be designed to facilitate safe pedestrian crossings to the TOD transit stop.

Discussion:

Transit passengers are likely to make frequent street crossings, some at mid-block, depending on the location and design of the transit stop. Adjacent street design must recognize the need for easy, safe, and fast pedestrian access, by providing sufficient auto and pedestrian visibility distances, stop signs or manually operated traffic signals, handicapped access, and clearly marked pedestrian crossings at signalized intersections.

Justification:

Most people will use transit only if it is fast, safe, and very convenient. Accessibility to transit stops must be given high priority in the design of streets to promote transit ridership. Street crossing placement, design and markings should recognize the need by transit riders for fast and flexible access to the stop.

Guideline 10D:

PARK AND RIDE LOTS

Park and ride lots are not appropriate for all trunk transit line stops. In Urban TODs, park and ride lots may be provided within structured parking lots located close to the transit stop. Surface parking lots specifically devoted to park and ride should not be provided in TODs. Rather, community-serving surface park and ride lots should be located at the ends of Trunk Line or Feeder Bus Line Networks or in Secondary Areas adjacent to, but outside, the boundaries of TODs.

Discussion:

Park and ride lots are best located adjacent to TODs or at other transit stops which do not have TODs. Surface parking lots specifically designed for park and ride, should be located adjacent to TODs with convenient pedestrian access to the transit stop or at the end of the trunk transit line.

Recognizing the need for parking facilities within Urban TODs to serve both the core commercial area and the transit stop, structured parking lots available to the public may be provided in Urban TODs. These community parking facilities should primarily serve the TOD and its Secondary Area. The size of the structured parking facility should be based on projected TOD and Secondary Area needs. These parking structures should be financed and constructed in conjunction with other TOD public improvements.

Justification:

While park and ride lots are extremely important components to building the ridership of the overall transit system, they do not necessarily augment the uses, activities, and densities of a TOD. The location and type of park and ride lots should be considered in terms of the goals and function of the entire transit system and should not detract from the TOD concepts.

11. Parking Requirements and Configuration

Guideline 11A:

PARKING STANDARDS

Reduced parking standards should be applied to Urban TODs in recognition of their proximity to high frequency transit service and their "walkable" environment and mix of uses. Current parking standards are recommended for Neighborhood TODs and Secondary Areas. Residential parking requirements are established by the Multi-Family Parking Ordinance and other City ordinances.

Discussion:

Reduced parking standards for residential development located in transit corridors and for mixed-use projects were adopted in 1989.

For non-residential development, parking standards vary based upon community characteristics such as pedestrian orientation and transit availability. The highest parking requirements are generally found in the newer, more suburban communities as follows:

Office	3.3 spaces/1,000 s.f.
Retail	5.0 spaces/1,000 s.f.
Light Industrial	2.5 spaces/1,000 s.f.

For Urban TODs, reduced minimum parking standards should be permitted as follows:

Land Use	Parking Reduction	Criteria
Residential	2-7%	Reduction permitted under adopted Multifamily Parking Standards in designated transit corridors and nodes; varies based upon LRT, bus service and Centre City locations.
Mixed-Use	2-7%	Reduction permitted under adopted Multifamily Parking Standards for the residential portion of projects with mixed uses in a single structure; varies based on percentage of commercial use.
Non-Residential	10-15%	Reductions of at least 10% should be permitted for all projects, while a reduction of as much as 15% may be appropriate for proximity to light rail transit, provision of office uses and other Transportation Demand Management considerations. This reduction may also be applied to the non-residential portion of mixed-use projects.

Maximum parking ratios should be established for non-residential uses in Urban TODs. Based upon further study, parking maximums should be set approximately within the following ranges:

Office	4-5 spaces/1,000 s.f.
Retail	5-6 spaces/1,000 s.f.
Light Industrial	3-4 spaces/1,000 s.f.

Both minimum and maximum parking standards should be reviewed at least every five years to determine whether further reductions are appropriate.

In preparing and implementing a parking ordinance, the following should be taken into consideration:

1. Communities using parking minimums which differs from the typical suburban requirements described above should be reviewed to determine the appropriate minimum and maximum standards.
2. Consistent with Guideline 9F and with the Multifamily Parking Standards, bike parking standards should be established for non-residential uses.
3. Parking studies should be conducted as necessary to evaluate project that have been granted parking reductions. If recommended by such studies, feasible mitigation measures should be implemented and included as features in future projects.

Justification:

Limited rather than ample parking supplies encourage commuter use of transit service.⁶ Minimum requirements help to avoid "spillover" parking in retail areas or nearby neighborhoods; maximums guard against overly generous parking supplies that discourage transit use and contribute to construction of large surface parking lots. Sample analysis of existing San Diego employers found that the most effective location for implementing reduced parking standards was in Urban TODs which are located along the trunk transit line network.

⁶ *Setting Parking Requirements for Transit-Oriented Development*, K.I. Analytics, Inc., for the City of San Diego.

Guideline 11B:

JOINT USE PARKING

Joint parking allowances are recommended for nearby uses with staggered peak periods of demand. Retail, office, and entertainment uses should share parking areas and quantities.

OFFICE

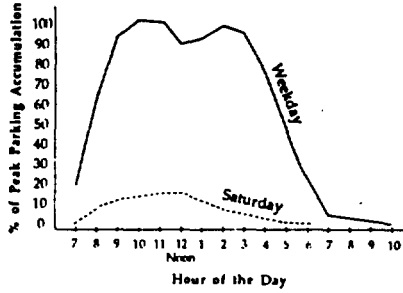

Discussion:

Projects with a mix of uses should seek to reduce the total number of parking spaces by comparing peak demand of each use by time of day, day of the week, and season. Where the varied parking demand for proximate uses allows joint use of a single parking facility, a reduced number of spaces is strongly encouraged. Shared parking areas should be conveniently located to all uses, but do not need to be located on the same parcel as the use.

RESTAURANT

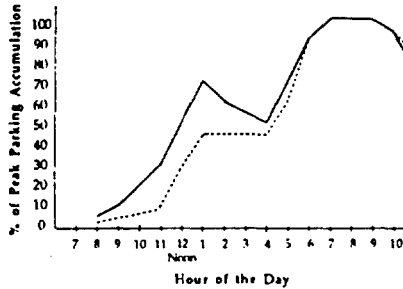

Justification:

The complementary relationship between land uses in a mixed-use area, such as a TOD, encourages multipurpose trips. Thus, a single parking space can serve several land uses. Additionally, peak parking demand for different land uses is often generated at different times during the day, week, or season. This also allows joint use of the same parking spaces for several uses. Reducing the amount of land devoted to parking within the TOD allows more efficient use of land closest to transit.

CINEMA

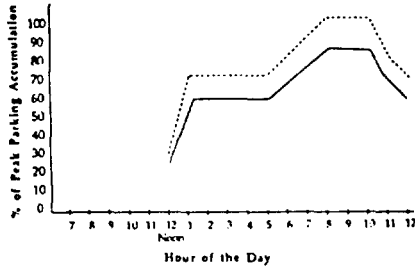

REGIONAL RETAIL

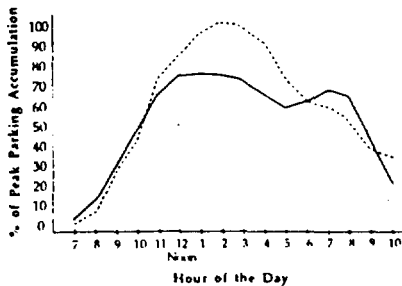

Guideline 11C:

PARKING CONFIGURATION

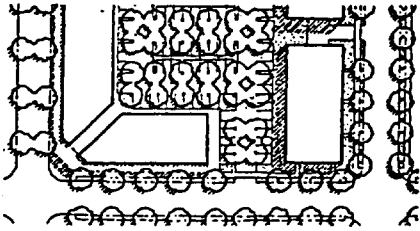

Parking lots should not dominate the frontage of pedestrian-oriented streets, interrupt pedestrian routes or negatively impact surrounding neighborhoods. Lots should be located behind buildings or in the interior of a block, whenever possible. Structured parking is also encouraged and future intensification with structured parking should be considered when designing development plans. The placement of bicycle parking facilities within automobile parking lots should be considered.

Discussion:

Parking lots that serve buildings facing pedestrian-oriented streets should be located to the rear of buildings. Parking lots should not occupy more than roughly 1/3 of the frontage, or no more than 75 feet, of a pedestrian-oriented street, such as retail "main streets" and local streets. Other streets may not be able to maintain this criteria.

Structured and below grade parking is strongly encouraged on Redevelopable and Urbanizing sites in conjunction with new development and as part of a comprehensive reuse plan; it is encouraged, but not required in New Growth Areas. Underground parking is preferred over above-ground structure parking. If structured parking is not immediately economically viable, development plans should indicate how structured parking and more intensive uses could be integrated into the site as a later date. The Uptown project in Hillcrest does a good job of creating an active streetscape while providing adequate parking spaces in an underground structure.

Justification:

An active pedestrian environment is stimulated by buildings at the sidewalk with numerous entries and visual stimuli; surface parking lots are "dead" spaces for pedestrians and drain the life of a street. At a minimum, parking lots should be placed behind buildings. Since surface parking can also lower densities and intensities--reducing transit ridership and the vitality of the TOD--surface lots should be minimized with structured parking and shared parking.

Guideline 11D:

**ON-STREET PARKING
REQUIREMENTS**

A portion of any project's parking requirements may be satisfied by on-street parking.

Discussion:

One space per residential unit when off-street parking is along alleys or the number of on-street parking spaces available on the contiguous street frontage of retail, office, or public use sites, may count against the total required number of parking spaces. To ease parking problems, on-site tandem parking is strongly encouraged.

Justification:

Utilizing on-street parking spaces to fulfill a portion of the total parking requirement will help reduce the amount of land devoted to parking, while continuing to provide the necessary amount of parking spaces.

Guideline 11E:

**PARKING MITIGATION
MEASURES**

Where reduced parking standards are utilized, mitigation measures should be considered to guard against "spill over" parking impacts. Preferential parking zones should be considered in residential neighborhoods and short term parking controls may be utilized in core commercial areas.

Discussion:

Where parking ratios are significantly reduced to take advantage of proximity to transit, analysis should be made to determine whether adjacent neighborhoods and shopping areas could be negatively affected by spill over parking during peak hours. Residential parking permits should be considered for neighborhoods; meters or short term parking zones should be considered for shopping areas.

Justifications:

While the parking guidelines for TODs are intended to not overly restrict parking demand, yet encourage carpooling, bicycling and transit use, in some cases the maximum parking demand for a particular area may be exceeded. Spillover parking can negatively affect surrounding neighborhoods and discourage shopping in commercial areas. Specific projects should be evaluated to determine if mitigation measures would be beneficial.

Guideline 11F:

**SIZE OF SURFACE
PARKING LOTS**

The size of any single surface parking lot shall be limited to 3 acres, unless divided by a street or building.

Discussion:

In no case shall a surface parking lot be larger than 3 acres, unless it is divided into several pieces. Large parking lots can be successfully segmented into smaller units by placing a street through two parking areas or locating a building between parking areas. If a single use will require a surface parking lot in excess of two acres, structured parking should be strongly encouraged.

Justification:

Large parking lots detract from a pedestrian emphasis and dedicate valuable land close to the transit system to non-rider-generating uses. Limiting the size of surface parking lots avoids these problems, while continuing to accommodate the siting needs of anchor retail tenants.

Guideline 11G:

**SURFACE PARKING
REDEVELOPMENT**

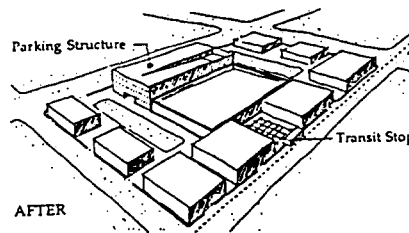
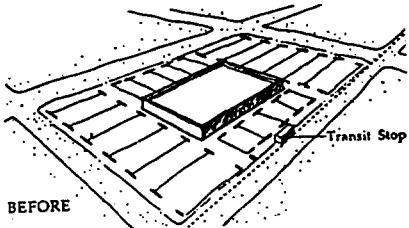

Land devoted to surface parking lots should be reduced through redevelopment and construction of structured parking facilities. Surface parking lots in TODs should be redeveloped to more intensive uses in the future.

Discussion:

Redevelopable sites with existing uses (such as the low-rise industrial buildings in Kearny Mesa) and existing light rail stations (such as the Palm Avenue Trolley stop in Nestor), may have surface parking lots that could be redeveloped with structured parking in order to more efficiently utilize the land near the transit stop.

Additionally, in early phases of a TOD, when land values are still relatively low, some sites may be developed with surface parking lots. Potential redevelopment of surface parking should be considered when the project is designed, and should be strongly encouraged to redevelop with more intensive uses as the TOD matures.

Justification:

Land in the vicinity of the transit stop should be developed with the greatest intensity in order to provide the most opportunities for transit ridership. As land values increase in TODs, redevelopment of surface parking lots to more intensive uses will augment this desired density.

Guideline 11H:

**RETAIL IN STRUCTURED
PARKING LOTS**

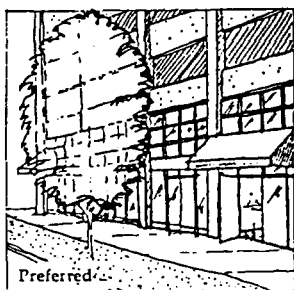
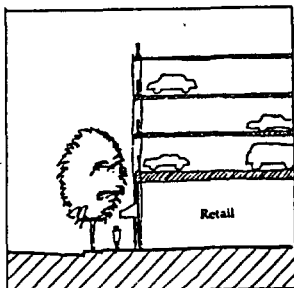

Retail uses should be encouraged on the first floor of street-side edges of parking structures.

Discussion:

Parking structures should not be allowed to dominate the street frontage in TODs. Retail uses should be located on the ground floor of parking garages and incorporated into the building's design. Office buildings can also be designed so that the active use portions of the building face the street and wrap around an interior parking structure. Portions of parking structures that do not have first level retail uses must be articulated and otherwise have an appearance similar to the building it serves.

Justification:

The City of San Diego has been very successful at preserving the life and activity at the street by requiring ground floor retail in parking structures. This ensures that streets remain interesting and active.

Guideline 11I:

**PARKING LOT
LANDSCAPING**

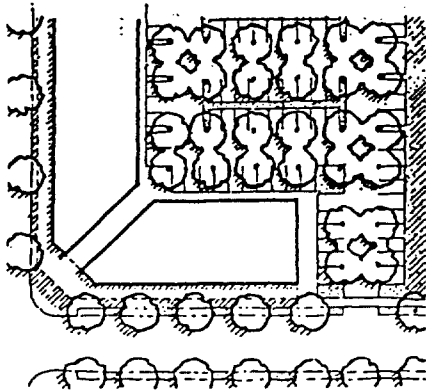

All parking lots must have sufficient trees so that within ten years 70 percent of the surface area of the lot is shaded. Additionally, all parking lots should be screened from streets by non-bermed landscape treatments. Views of retail facades must not be blocked.

Discussion:

This guideline is intended to achieve a quality of environment that is comfortable to pedestrians. Trees should be located along walkways; perimeter landscaping should screen views of cars, but not block views of retail facades. Tree canopies should be trimmed to provide shade, but should allow building visibility. Attention should also be given to the use of permeable paving surfaces to reduce surface water runoff.

Justification:

Trees and other landscaping are particularly important for surface parking lots which absorb significant amounts of solar heat and create uncomfortable places for pedestrians. Landscaping along parking lot perimeters should also be provided to soften the visual impact of rows of parked cars and define the edge of the sidewalk. Landscaping and paving surfaces that allow water to soak into the ground can help reduce surface water runoff that pollutes San Diego's streams, bays and ocean waters.

Incentives & Implementation Strategies

Incentives and other implementation measures are necessary to encourage developers to utilize transit-oriented development patterns, as well as provide a supporting basis for long-range land use and transportation planning. These strategies should provide a clear process for implementing the TOD Concept, as well as allow flexibility in interpreting the design guidelines.

The following recommendations are based on discussions with City staff, the Land Guidance Committee, and participants of the Focus Group sessions. Each category identifies "immediate action items" and "on-going strategies." In all cases, these implementation measures are intended to coincide to the greatest degree possible with existing planning processes and projects already underway by a number of City departments. Additional new implementation mechanisms are also recommended which are necessary to properly bring together the numerous perspectives embodied in the TOD concept.

Long-Range Planning

Immediate Action Items:

- Adopt these TOD Design Guidelines and Implementation Strategies by resolution of the City Council.
- Adopt a City Council Policy that outlines a phased TOD implementation strategy.
- TOD demonstration projects should be allowed to proceed in advance of comprehensive revisions to existing City codes, standards, and guidelines (including the City's street design manual), provided adequate conditions and monitoring procedures are implemented to minimize City liability.

On-Going Strategies:

- Community plans should be used as "pro-active" tools to designate transit corridors and planning for mixed-use and transit-supportive land uses along existing or planned transit corridors. Community plans should identify appropriate sites for TODs, Secondary Areas, transit facilities, bicycle routes, pedestrian paths, open space, resource protection, and other non-TOD uses along existing and planned transit corridors. New transit corridors should be planned in conjunction with MTDB staff to ensure that adequate sites are available for TODs and that densities necessary to support transit can be achieved. Community plan updates should continue to be grouped to allow for comprehensive transportation corridor planning that crosses community plan boundaries. This would apply to both New Growth Areas and Redevelopable and Urbanizing sites.
- As community plans are updated and TOD Opportunity Areas are identified, land use and circulation plans and policies should be amended accordingly. Residential densities, commercial/industrial intensities, and the appropriate mix of uses within TODs should be clarified. TODs located in existing developed areas should be designed such that existing residential densities and commercial uses are complemented, without causing significant traffic, infrastructure and public service impacts.

- Planned development permits, redevelopment area plans, and other mechanisms should be used, as appropriate, to implement TOD projects and to ensure that facilities financing and neighborhood character issues are addressed. Individual TOD sites should be encouraged to prepare coordinated plans which provide land use, circulation, infrastructure, and financing plans, as well as traffic studies and environmental review. Proposals may be initiated by either the City, individual property owners, or a group of cooperating property owners. Proposals on TOD sites must demonstrate how the TOD Design Guidelines are applied and adhered to.
- In the course of an update to the General Plan Land Use and Transportation Elements, amendments should be processed to emphasize non-automobile travel opportunities, to identify additional areas where transit-oriented development is desirable, and to reconcile potential conflicts among sensitive resource protection, neighborhood character preservation and transportation corridor expansion goals.
- Through the normal course of discretionary project review, the City should encourage proposed projects fully or partially located within 2,000 feet of an existing or planned light rail transit, commuter rail, express bus or transit corridor stop, as identified on Council-approved transit alignment maps, to incorporate elements of the Transit-Oriented Development Design Guidelines into project design.

If existing community plans have not yet been updated with regard to the TOD guidelines, and a property owner desires to construct a project that meets the site selection and development criteria of the TOD guidelines, the City should offer an expedited plan amendment and discretionary permit process, while still ensuring opportunities for full community input.

Environmental Review and Permit Processing

On-Going Strategies:

- The Process Management effort to streamline permit processing should be continued. Planning and evaluating TOD proposals should clearly identify accepted procedures and time limit goals for TOD specific plans, EIRs, tentative maps, and site plan review.
- If a specific plan, planned development permit, or other discretionary permit is prepared for an individual TOD site or a series of TODs, a single EIR and traffic study should be required; no subsequent environmental review should be necessary, unless a submitted plan does not conform with the adopted environmental document. State Law (Gov't. Code Sec. 65450 et seq.) presently allows construction of housing developments that are consistent with the criteria and standards of an adopted specific plan and its EIR to proceed without further environmental review. This should be extended to all uses within the plan area, provided the proposed project is within the range of allowable uses and densities (i.e. amount and type of housing, commercial, industrial, and public uses), conforms to other land use and circulation policies, meets the TOD and specific plan design guidelines, and conforms to the requirements of the plan's implementation program. This will require specific plans and their EIR's to provide some flexibility in the range and amount of allowable uses, yet ensure enough clarity in their land use programs to adequately assess potential environmental impacts.

- Traffic Level of Service (LOS) and design speeds should be reconciled with the intent of the TOD concept during environmental review, traffic study, and facilities planning for TOD projects. In all cases, regionally significant roads, such as arterials, thoroughfares, expressways, and freeways, should continue to achieve high levels of service at acceptable travel speeds. Local streets within TODs should not be held to the same standards; TOD streets should allow reduced speeds and lower levels of service, provided pedestrian and vehicle safety is maintained.

Zoning and City Standards

On-Going Strategies:

- Existing zoning regulations should be amended and new zoning tools created to incorporate the concepts of the TOD guidelines into city wide site development standards. To the extent possible, individual developments within TODs should be permitted to proceed through ministerial, rather than discretionary processes. These standards and processes should be closely coordinated with the current zoning code update process.
- Efforts to revise the Street Design Manual should be continued, with emphasis on establishing specific street width and configuration standards that realize the intent of the Design Guidelines. In particular, standards for local streets, new "connector" streets, alleys, sidewalks, street trees, and on-street parking should be reviewed and amended.
- The TOD guidelines should be used to develop more specific zoning regulations to facilitate mixed-use projects. These standards should focus on determining appropriate types of permitted uses, residential densities and commercial intensities, intensity of site use, providing street and pedestrian connections with adjacent parcels, and site buffering.
- In accordance with State law, the City has adopted an ordinance to authorize companion units (granny flats) under certain conditions. To date, only a handful of companion units have actually been authorized. The Planning Department should propose amendments to the companion unit ordinance to enable their more widespread use as an affordable housing resource. These amendments could include allowing construction of detached second rental units on existing parcels, provided the single- or multi-family character of the neighborhood is not altered and modifying current vacancy rate restrictions. These amendments should also include the development of standards which would outline the minimum lot size, parking, and transit access requirements for both the ministerial and discretionary approval of such units.
- Revise city wide parking standards to be consistent with the TOD Design Guidelines, specifically related to the number of spaces and the configuration and size of parking lots.
- Through the standard permit review process, TOD plans should be reviewed to determine whether Residential Permit Parking Zones and time limit parking in commercial areas would be necessary.
- In conjunction with community plan updates and specific plans, review land use designations and zoning maps to minimize competing retail and office uses outside of TODs and Secondary Areas, as well as minimizing highly auto-dependent uses within the TOD and Secondary Area boundaries.

Public Services and Infrastructure

On-Going Strategies:

- TODs located in existing developed areas on Redevelopable and Urbanizing Sites must address existing and potential infrastructure and public facility deficiencies. If necessary, additional parks should be provided and other infrastructure capacity constraints corrected.
- Public facilities and services, such as libraries, parks and recreation centers, should be located in TODs, whenever possible to provide patrons a transit travel option and to strengthen the sense of community in neighborhoods.
- Encourage the Park and Recreation Department to allow TODs to meet the City's park standards through the use of small and frequent parks and plazas.
- TOD specific plans must include a coordinated infrastructure financing plan which indicates how on- and off-site infrastructure and other public improvements shall be financed. Where a specific plan is not prepared, or a proposed project is for only a portion of a TOD, any necessary infrastructure improvements and associated costs must be identified and an appropriate financing method recommended with the planned development permit or individual project application.
- In recognition of the cumulative fiscal benefits resulting from a more efficient urban form, fees for TODs should be reduced. The reduction must be linked to a demonstrated reduction in need for facilities to serve TOD developments.