

NOTES:

1. CEMENT SLURRY BACKFILL SHALL BE THOROUGHLY CONSOLIDATED, AND HAVE A MAXIMUM SLUMP OF 4 INCHES. FLY ASH MEETING THE REQUIREMENTS OF 201-1.2.5.3 MAY BE ADDED (NOT AS A SUBSTITUTE) TO THE MINIMUM CEMENT REQUIREMENTS. SLURRY COMBINED GRADING SHALL MEET REQUIREMENTS OF 201-1.3.2 GRADING D. CEMENT SLURRY BACKFILL SHALL BE 100-D-100.
2. SLURRY SHALL BE CURED A MINIMUM OF 48 HOURS PRIOR TO PLACEMENT OF CLASS II BASE AND ASPHALT CONCRETE. RESURFACING SHALL BE COMPLETED IN NO MORE THAN 7 DAYS AFTER PLACEMENT OF CEMENT SLURRY.
3. ALL ASPHALT STREET RESURFACING SHALL EXTEND A MINIMUM OF 6 INCHES BEYOND EDGE OF POTHOLE OR EXPLORATORY EXCAVATION, AS SHOWN. ASPHALT THICKNESS TO EQUAL EXISTING AC PAVEMENT PLUS 1 INCH (4 INCHES MINIMUM TO 9 INCHES MAXIMUM). COMBINED ASPHALT PLUS BASE SHALL BE 18 INCHES MINIMUM.
4. IF UTILITY IS ENCOUNTERED, AS LISTED BELOW, PLACE BEDDING A MINIMUM OF 6 INCHES ABOVE UTILITY.
 - A. WATER UTILITY: SE 50 SAND
 - B. SEWER UTILITY: 3/8" MAXIMUM AGGREGATE
 - C. DRY UTILITY: SE 50 SAND
5. FOR PCC SURFACED STREETS, **SEE SDG-108** FOR RESURFACING. FOR POTHOLE AND EXPLORATORY EXCAVATION LARGER THAN 3'-0" ON ASPHALT CONCRETE SURFACED STREETS, SEE SDG-107 FOR RESURFACING.
6. POTHOLE OR EXPLORATORY EXCAVATION IN BIKE LANES SHALL BE APPROVED BY THE CITY. IF APPROVED, THE ENTIRE WIDTH OF THE BIKE LANE SHALL BE RESURFACED, AT A MINIMUM LENGTH OF 6 FEET.
7. TEMPORARY RESURFACING IS ALLOWED IF CONSTRUCTION WILL BE PERFORMED WITHIN 60 DAYS AFTER POTHOLING WORK, IF POTHOLE OR EXPLORATORY EXCAVATION IS WITHIN THE NEW TRENCH LIMITS, AND **IF APPROVED BY THE CITY**. MATERIAL FOR TEMPORARY RESURFACING **SHALL BE APPROVED BY THE CITY**. SEE NOTE 3 FOR LIMITS AND DEPTH.
8. PAVEMENT CORES SHALL NOT BE GREATER THAN 3'-0" IN DIAMETER, AND SHALL NOT BE SPACED CLOSER THAN 3 FEET BETWEEN CORES, EDGE TO EDGE.
9. SEE SHEET 2 FOR TYPE B - KEYHOLE METHOD.

SHEET 1 OF 2

REVISION	BY	APPROVED	DATE
ORIGINAL	CD	J. NAGELVOORT	11/17
UPDATED	CD	J. NAGELVOORT	09/18
UPDATED	FM	R. AMEN	12/23

CITY OF SAN DIEGO - STANDARD DRAWING

36" AND SMALLER POTHOLE AND EXPLORATORY EXCAVATION - TYPE A PAVEMENT REPAIR

RECOMMENDED BY THE CITY OF SAN DIEGO STANDARDS COMMITTEE

Alaine James 12/15/2023
COORDINATOR R.C.E. 81047 DATE

DRAWING NUMBER **SDG-123**

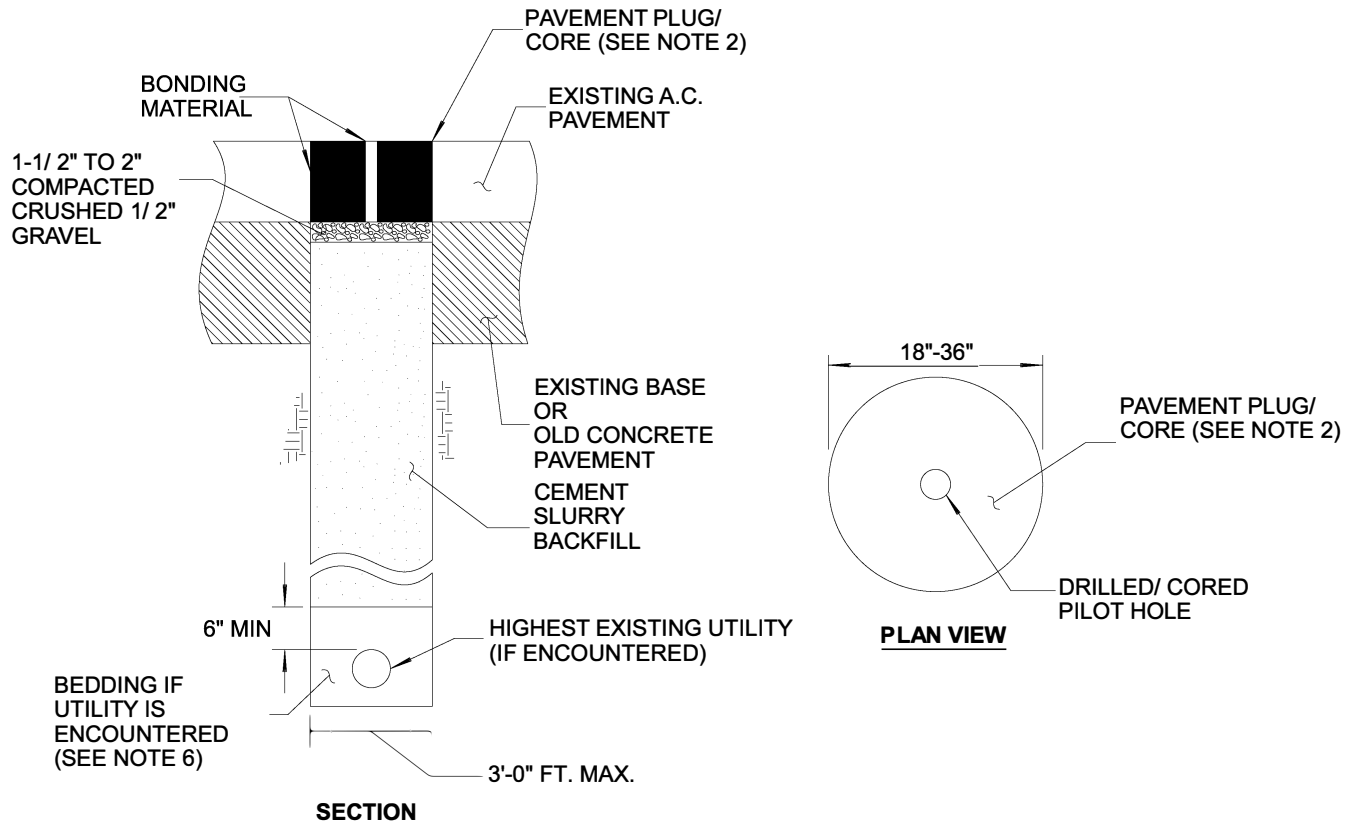

NOTES:

1. PAVEMENT CORE TO BE REINSTATED SHALL BE A MINIMUM OF 4 INCHES THICK AND SHALL NOT CONTAIN JOINTS OR CRACKS WHICH MAY CAUSE IT TO BREAK AND SPALL. OTHERWISE, TYPE "A" PER SHEET 1 SHALL BE USED **AS DIRECTED BY CITY ENGINEER.**
2. CUT, REMOVE, AND REINSTATE PAVEMENT CORE, FLUSH WITH EXISTING PAVEMENT. THE REMOVED PAVEMENT CORE/ PLUG WITH ASPHALT AND CONCRETE BASE SHALL BE UTILIZED AND REINSTALLED IN GOOD CONDITION.
3. BONDING MATERIAL SHALL BE AS SPECIFIED **PER CITY APPROVED MATERIALS LIST.**
4. CEMENT SLURRY BACKFILL SHALL BE THOROUGHLY CONSOLIDATED, AND HAVE A MAXIMUM SLUMP OF 4 INCHES. FLY ASH MEETING THE REQUIREMENTS OF 201-1.2.5.3 MAY BE ADDED (NOT AS A SUBSTITUTE) TO THE MINIMUM CEMENT REQUIREMENTS. SLURRY COMBINED GRADING SHALL MEET REQUIREMENTS OF 201-1.3.2 GRADING D. CEMENT SLURRY BACKFILL SHALL BE 100-D-100.
5. SLURRY SHALL BE CURED A MINIMUM OF 48 HOURS PRIOR TO PLACEMENT OF CLASS II BASE AND ASPHALT CONCRETE. RESURFACING SHALL BE COMPLETED IN NO MORE THAN 7 DAYS AFTER PLACEMENT OF CEMENT SLURRY.
6. IF UTILITY IS ENCOUNTERED, AS LISTED BELOW, PLACE BEDDING A MINIMUM OF 6 INCHES ABOVE UTILITY.
 - A. WATER UTILITY: SE 50 SAND
 - B. SEWER UTILITY: 3/ 8" MAXIMUM AGGREGATE
 - C. DRY UTILITY: SE 50 SAND
7. FOR CONCRETE SURFACED STREETS, **SEE SDG-108** FOR RESURFACING. FOR POTHOLE AND EXPLORATORY EXCAVATION LARGER THAN 3'-0" ON ASPHALT CONCRETE SURFACED STREETS, SEE SDG-107 FOR RESURFACING.
8. POTHOLE OR EXPLORATORY EXCAVATION IN BIKE LANES **SHALL BE APPROVED BY THE CITY.**
9. PAVEMENT CORES SHALL NOT BE GREATER THAN 3'-0" INCHES IN DIAMETER, AND SHALL NOT BE SPACED CLOSER THAN 3 FEET BETWEEN CORES, EDGE TO EDGE.

SHEET 2 OF 2

REVISION	BY	APPROVED	DATE	CITY OF SAN DIEGO - STANDARD DRAWING	RECOMMENDED BY THE CITY OF SAN DIEGO STANDARDS COMMITTEE
ORIGINAL	CD	J. NAGELVOORT	11/17		
UPDATED	CD	J. NAGELVOORT	09/18	36" AND SMALLER EXPLORATORY EXCAVATION POTHOLE - TYPE B KEYHOLE METHOD	<i>Alaine James</i> 12/15/2023 COORDINATOR R.C.E. 81047 DATE
UPDATED	FM	R. AMEN	12/23		
				DRAWING NUMBER	SDG-123