

# City of San Diego

**CONTRACTOR'S NAME:** S.C. Valley Engineering, Inc

**ADDRESS:** 656 Front St., El Cajon, CA 92020

**TELEPHONE NO.:** 619-444-2366

**FAX NO.:** \_\_\_\_\_

**CITY CONTACT:** Rosa Riego, Senior Contract Specialist, Email: [RRiego@sandiego.gov](mailto:RRiego@sandiego.gov)

Phone No. (619) 533-3426

R. Valadez / T. Dinh / L. Russell

## BIDDING DOCUMENTS



**FOR**

## BAY HO IMPROV 2

**BID NO.:** K-24-2247-DBB-3

**SAP NO. (WBS/IO/CC):** B-19104, B-19106

**CLIENT DEPARTMENT:** 2000

**COUNCIL DISTRICT:** 2

**PROJECT TYPE:** JA, KB

**THIS CONTRACT WILL BE SUBJECT TO THE FOLLOWING:**

- THE CITY'S SUBCONTRACTING PARTICIPATION REQUIREMENTS FOR SLBE PROGRAM
- PREVAILING WAGE RATES: STATE  FEDERAL
- APPRENTICESHIP

**THIS CONTRACT MAY BE SUBJECT TO THE FOLLOWING:**

- PHASED-FUNDING

**BID DUE DATE:**

**2:00 PM**

**FEBRUARY 28, 2024**

**CITY OF SAN DIEGO'S ELECTRONIC BIDDING SITE, PLANETBIDS**

<http://www.sandiego.gov/cip/bidopps/>

**ENGINEER OF WORK**

The engineering Specifications and Special Provisions contained herein have been prepared by or under the direction of the following Registered Engineers:

  
\_\_\_\_\_  
1) City Engineer

01/04/2024  
\_\_\_\_\_  
Date

Seal:



  
\_\_\_\_\_  
2) Registered Engineer

January 4, 2024  
\_\_\_\_\_  
Date

Seal:

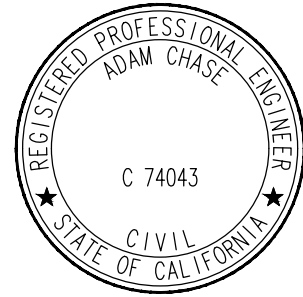

**Bay Ho Improv 2 Plans numbered 42048-55-D through 42048-86-D and the associated specifications.**

  
\_\_\_\_\_  
3) Registered Engineer

January 4, 2024  
\_\_\_\_\_  
Date

Seal:



**Bay Ho Improv 2 Plans numbered 42048-87-D and 42048-88-D and the associated specifications.**

*Vicki Estrada*

January 3, 2024

Seal:



4) Registered Architect

Date

**Bay Ho Improv 2 Plans numbered 42048-L1-D through 42048-L3-D and the associated specifications.**

*[Signature]*

1/8/2024

Seal:



5) City Engineer

Date

**Bay Ho Improv 2 Plans numbered 42048-TC1-D through 42048-TC13-D and the associated specifications.**

## TABLE OF CONTENTS

SECTION	PAGE
1. REQUIRED DOCUMENTS SCHEDULE.....	5
2. NOTICE INVITING BIDS.....	7
3. INSTRUCTIONS TO BIDDERS .....	11
4. PERFORMANCE AND PAYMENT BONDS .....	21
5. ATTACHMENTS:	
A. SCOPE OF WORK.....	24
B. PHASED FUNDING PROVISIONS .....	26
C. EQUAL OPPORTUNITY CONTRACTING PROGRAM .....	30
D. PREVAILING WAGE.....	50
E. SUPPLEMENTARY SPECIAL PROVISIONS.....	55
1. Appendix A - Addendum to Mitigated Negative Declaration .....	94
2. Appendix B - Fire Hydrant Meter Program .....	114
3. Appendix C - Materials Typically Accepted by Certificate of Compliance.....	128
4. Appendix D - Sample City Invoice with Cash Flow Forecast.....	130
5. Appendix E - Location Map .....	133
6. Appendix F - Adjacent Projects Map.....	135
7. Appendix G - Contractor’s Daily Quality Control Inspection Report.....	137
8. Appendix H - Monthly Drinking Water Discharge Monitoring Form.....	140
9. Appendix I - Hazardous Waste Label/Forms .....	143
10. Appendix J - Rehabilitation Data Collection - Sample Sewer Mains, Laterals, Manholes, Data Templates .....	149
11. Appendix K - Sample Archaeology Invoice.....	153
12. Appendix L - Advanced Metering Infrastructure (AMI) Device Protection .....	156
13. Appendix M - Standard Drawings.....	163
F. IN-USE OFF-ROAD DIESEL FUELED FLEET REGULATION (OFF-ROAD REGULATION) COMPLIANCE (CARB) .....	182
G. CONTRACT AGREEMENT .....	186
6. CERTIFICATIONS AND FORMS.....	189

## REQUIRED DOCUMENTS SCHEDULE DURING BIDDING AND AWARDING

The Bidder's attention is directed to the City's Municipal Code §22.0807(d)(2) for important information regarding grounds for debarment for failure to submit required documentation.

The specified Equal Opportunity Contracting Program (EOCP) forms are available for download from the City's web site at:

<http://www.sandiego.gov/eoc/forms/index.shtml>

ITEM	DOCUMENT TO BE SUBMITTED	WHEN DUE	FROM
1.	Bid Bond (PDF via PlanetBids)	At Time of Bid	ALL BIDDERS
2.	Contractors Certification of Pending Actions	At Time of Bid	ALL BIDDERS
3.	List of Subcontractors for Alternate Items	At Time of Bid	ALL BIDDERS
4.	Mandatory Disclosure of Business Interests	At Time of Bid	ALL BIDDERS
5.	Debarment and Suspension Certification for Prime Contractors	At Time of Bid	ALL BIDDERS
6.	Debarment and Suspension Certification for Subcontractors, Suppliers & Mfgs	At Time of Bid	ALL BIDDERS
7.	Bid Bond (Original)	By 5 PM 1 working day after bid opening	ALL BIDDERS
8.	SLBE Good Faith Effort Documentation	By 5 PM 3 working days after bid opening	ALL BIDDERS
9.	Form AA60 – List of Work Made Available	By 5 PM 3 working days after bid opening with Good Faith Effort (GFE) documentation	ALL BIDDERS
10.	Phased Funding Schedule Agreement (when required)	Within 10 working days of the Notice of Intent to Award	AWARDED BIDDER
11.	If the Contractor is a Joint Venture: <ul style="list-style-type: none"> <li>• Joint Venture Agreement</li> <li>• Joint Venture License</li> </ul>	Within 10 working days of receipt by bidder of contract forms	AWARDED BIDDER

ITEM	DOCUMENT TO BE SUBMITTED	WHEN DUE	FROM
12.	In-Use Off-Road Diesel Fueled Fleet Regulation (OFF-ROAD REGULATION) Compliance	Within 10 working days of receipt by bidder of contract forms and NOI	AWARDED BIDDER
13.	Payment & Performance Bond: Certificates of Insurance & Endorsements	Within 10 working days of receipt by bidder of contract forms and NOI	AWARDED BIDDER
14.	Signed Contract Agreement Page	Within 3 working days of receipt by bidder of Contract Agreement	AWARDED BIDDER
15.	Listing of "Other Than First Tier" Subcontractors	Within 10 working days of receipt by bidder of contract forms	AWARDED BIDDER

## NOTICE INVITING BIDS

1. **SUMMARY OF WORK:** This is the City of San Diego's (City) solicitation process to acquire Construction services for **BAY HO IMPROV 2**. For additional information refer to Attachment A.
2. **FULL AND OPEN COMPETITION:** This solicitation is subject to full and open competition and may be bid by Contractors on the City's approved Prequalified Contractors List. For information regarding the Contractors Prequalified list visit the City's web site: <http://www.sandiego.gov>.
3. **ESTIMATED CONSTRUCTION COST:** The City's estimated construction cost for this project is **\$18,300,000**.
4. **BID DUE DATE AND TIME ARE: February 28, 2024 at 2:00 PM.**
5. **PREVAILING WAGE RATES APPLY TO THIS CONTRACT:** Refer to Attachment D.
6. **LICENSE REQUIREMENT:** To be eligible for award of this contract, Prime contractor must possess the following licensing classification: **A or [C-34 and C-42]**
7. **SUBCONTRACTING PARTICIPATION PERCENTAGES:** Subcontracting participation percentages apply to this contract.
  - 7.1. The City has incorporated **mandatory** SLBE-ELBE subcontractor participation percentages to enhance competition and maximize subcontracting opportunities. For the purpose of achieving the mandatory subcontractor participation percentages, a recommended breakdown of the SLBE and ELBE subcontractor participation percentages based upon certified SLBE and ELBE firms has also been provided to achieve the mandatory subcontractor participation percentages:

1. SLBE participation	<b>8.6%</b>
2. ELBE participation	<b>13.7%</b>
3. Total mandatory participation	<b>22.3%</b>
  - 7.2. The current list of Certified SLBE/ELBE Firms to be used for outreach for this project is posted to the Documents tab on PlanetBids.
  - 7.3. The Bid may be declared non-responsive if the Bidder fails to meet the following requirements:
    - 7.3.1. Include SLBE-ELBE certified subcontractors at the overall mandatory participation percentage identified in this document; OR
    - 7.3.2. Submit Good Faith Effort (GFE) documentation, saved in searchable Portable Document Format (PDF), demonstrating the Bidder made a good faith effort to conduct outreach to and include SLBE-ELBE Subcontractors as required in

this solicitation by 5 PM 3 Working Days after the Bid opening if the overall mandatory participation percentage is not met.

**All submittals in searchable PDF shall be submitted electronically within the prescribed time identified in the contract documents via PlanetBids by invitation to the point of contact named in the bid provided by the Contract Specialist to all bidders.**

## 8. PRE-BID MEETING:

### 8.1 ONLINE PRE-BID MEETING:

Prospective Bidders are **encouraged** to attend the Pre-Bid Meeting.

The Pre-Bid Meeting will be held on **Thursday, January 25, 2024, at 10:00 AM (PDT)** at:

## Microsoft Teams meeting

**Join on your computer, mobile app or room device**

[Click here to join the meeting](#)

Meeting ID: 267 518 176 136

Passcode: rb8YCz

[Download Teams](#) | [Join on the web](#)

**Or call in (audio only)**

[+1 945-468-5511,,855043153#](#) United States, Dallas

Phone Conference ID: 855 043 153#

[Find a local number](#) | [Reset PIN](#)

[Learn More](#) | [Meeting options](#)

**Please Note:** You will need to join the meeting with a computer, tablet or smartphone with the **Microsoft Teams** in order to sign in via the Chat feature as attendance at the meeting will be evidenced by the Chat sign-in. The Chat feature will also be used for attendees to ask any questions.

The purpose of the meeting is to discuss the scope of the Project, submittal requirements, and any Equal Opportunity Contracting Program requirements and reporting procedures.

Upon entering the meeting, all attendees must use the chat feature to sign in with the following information: Name of firm, Attendee's name, Phone number and Email address.



**9. AWARD PROCESS:**

- 9.1** The Award of this contract is contingent upon the Contractor's compliance with all conditions of Award as stated within these documents and within the Notice of Intent to Award.
- 9.2** Upon acceptance of bids and determination of the apparent low bidder, the City will prepare the contract documents for execution within approximately 21 days of the date of the bid opening. The City will then award the contract upon receipt of properly signed Contract, bonds, and insurance documents.
- 9.3** This contract will be deemed executed and effective only upon the signing of the Contract by the Mayor or his designee and approval as to form by the City Attorney's Office.
- 9.4** The low Bid will be determined by the Base Bid plus all the Alternates.
- 9.5** Once the low Bid has been determined, the City may, at its sole discretion, award the contract for the Base Bid plus one or more Alternates.

**10. SUBMISSION OF QUESTIONS:**

- 10.1** The Director (or Designee) of the Purchasing & Contracting Department is the officer responsible for opening, examining, and evaluating the competitive Bids submitted to the City for the acquisition, construction and completion of any public improvement except when otherwise set forth in these documents. Any questions related to this solicitation shall be submitted to:

[RRiego@sandiego.gov](mailto:RRiego@sandiego.gov)

- 10.2** Questions received less than 14 days prior to the date for opening of Bids may not be considered.
- 10.3** Questions or clarifications deemed by the City to be material shall be answered via issuance of an addendum and posted to the City's online bidding service.
- 10.4** Only questions answered by formal written addenda shall be binding. Oral and other interpretations or clarifications shall be without legal effect. It is the Bidder's responsibility to be informed of any addenda that have been issued and to include all such information in its Bid.

- 11. PHASED FUNDING:** This contract may be subject to phased funding, for Conditions, see Attachment B.

**12. ADDITIVE/DEDUCTIVE ALTERNATES:**

- 12.1** The additive/deductive alternates have been established to allow the City to compare the cost of specific portions of the Work with the Project's budget and enable the City to make a decision whether to incorporate these portions prior to award. The award

will be established as described in the Bid. The City reserves the right to award the Contract for the Base Bid only or for the Base Bid plus one or more Alternates.

- 12.2** For water pipeline projects, the Plans typically show all cut and plug and connection work to be performed by City Forces. However, Bidders shall refer to Bidding Documents to see if all or part of this work will be performed by the Contractor.

## INSTRUCTIONS TO BIDDERS

### 1. PREQUALIFICATION OF CONTRACTORS:

- 1.1. Contractors submitting a Bid must be pre-qualified for the total amount proposed, including all alternate items, prior to the date of submittal. Bids from contractors who have not been pre-qualified as applicable and Bids that exceed the maximum dollar amount at which contractors are pre-qualified may be deemed **non-responsive** and ineligible for award.
- 1.2. The completed application must be submitted online no later than 2 weeks prior to the bid opening.
- 1.3. **Joint Venture Bidders Cumulative Maximum Bidding Capacity:** For projects with an engineer's estimate of \$30,000,000 or greater, Joint Ventures submitting bids may be deemed responsive and eligible for award if the cumulative maximum bidding capacity of the individual Joint Venture entities is equal to or greater than the total amount proposed.
  - 1.3.1. Each of the entities of the Joint Venture must have been previously prequalified at a minimum of \$15,000,000.
  - 1.3.2. Bids submitted with a total amount proposed of less than \$30,000,000 are not eligible for Cumulative Maximum Bidding Capacity prequalification. To be eligible for award in this scenario, the Joint Venture itself or at least one of the Joint Venture entities must have been prequalified for the total amount proposed.
  - 1.3.3. Bids submitted by Joint Ventures with a total amount proposed of \$30,000,000 or greater on a project with an engineer's estimate of less than \$30,000,000 are not eligible for Cumulative Maximum Bidding Capacity prequalification.
  - 1.3.4. The Joint Venture designated as the Apparent Low Bidder shall provide evidence of its corporate existence and furnish good and approved bonds in the name of the Joint Venture within 14 Calendar Days of receipt by the Bidder of a form of contract for execution.
- 1.4. Complete information and links to the on-line prequalification application are available at:  
  
<http://www.sandiego.gov/cip/bidopps/prequalification>
- 1.5. Due to the City's responsibility to protect the confidentiality of the contractors' information, City staff will not be able to provide information regarding contractors' prequalification status over the telephone. Contractors may access real-time information about their prequalification status via their vendor profile on [PlanetBids.™](#)

2. **ELECTRONIC FORMAT RECEIPT AND OPENING OF BIDS:** Bids will be received in electronic format (eBids) EXCLUSIVELY at the City of San Diego's electronic bidding (eBidding) site, at: <http://www.sandiego.gov/cip/bidopps/> and are due by the date, and time shown on the cover of this solicitation.
- 2.1. **BIDDERS MUST BE PRE-REGISTERED** with the City's bidding system and possess a system-assigned Digital ID in order to submit an electronic bid.
- 2.2. The City's bidding system will automatically track information submitted to the site including IP addresses, browsers being used and the URLs from which information was submitted. In addition, the City's bidding system will keep a history of every login instance including the time of login, and other information about the user's computer configuration such as the operating system, browser type, version, and more. Because of these security features, Contractors who disable their browsers' cookies will not be able to log in and use the City's bidding system.
- 2.3. The City's electronic bidding system is responsible for bid tabulations. Upon the bidder's or proposer's entry of their bid, the system will ensure that all required fields are entered. **The system will not accept a bid for which any required information is missing.** This includes all necessary pricing, subcontractor listing(s) and any other essential documentation and supporting materials and forms requested or contained in these solicitation documents.
- 2.4. **BIDS REMAIN SEALED UNTIL BID DEADLINE.** eBids are transmitted into the City's bidding system via hypertext transfer protocol secure (https) mechanism using SSL 128-256 bit security certificates issued from Verisign/Thawte which encrypts data being transferred from client to server. Bids submitted prior to the "Bid Due Date and Time" are not available for review by anyone other than the submitter who has until the "Bid Due Date and Time" to change, rescind or retrieve its proposal should it desire to do so.
- 2.5. **BIDS MUST BE SUBMITTED BY BID DUE DATE AND TIME.** Once the bid deadline is reached, no further submissions are accepted into the system. Once the Bid Due Date and Time has lapsed, bidders, proposers, the general public, and City staff are able to immediately see the results on line. City staff may then begin reviewing the submissions for responsiveness, EOCB compliance and other issues. The City may require any Bidder to furnish statement of experience, financial responsibility, technical ability, equipment, and references.
- 2.6. **RECAPITULATION OF THE WORK.** Bids shall not contain any recapitulation of the Work. Conditional Bids may be rejected as being non-responsive. Alternative proposals will not be considered unless called for.

**2.7. BIDS MAY BE WITHDRAWN** by the Bidder only up to the bid due date and time.

**2.7.1. Important Note:** Submission of the electronic bid into the system may not be instantaneous. Due to the speed and capabilities of the user's internet service provider (ISP), bandwidth, computer hardware and other variables, it may take time for the bidder's submission to upload and be received by the City's eBidding system. It is the bidder's sole responsibility to ensure their bids are received on time by the City's eBidding system. The City of San Diego is not responsible for bids that do not arrive by the required date and time.

**2.8. ACCESSIBILITY AND AMERICANS WITH DISABILITIES ACT (ADA) COMPLIANCE:** To request a copy of this solicitation in an alternative format, contact the Purchasing & Contracting Department, Public Works Division Contract Specialist listed on the cover of this solicitation at least five (5) working days prior to the Bid/Proposal due date to ensure availability.

**3. ELECTRONIC BID SUBMISSIONS CARRY FULL FORCE AND EFFECT:**

**3.1.** The bidder, by submitting its electronic bid, acknowledges that doing so carries the same force and full legal effect as a paper submission with a longhand (wet) signature.

**3.2.** By submitting an electronic bid, the bidder certifies that the bidder has thoroughly examined and understands the entire Contract Documents (which consist of the plans and specifications, drawings, forms, affidavits and the solicitation documents), and that by submitting the eBid as its bid proposal, the bidder acknowledges, agrees to and is bound by the entire Contract Documents, including any addenda issued thereto, and incorporated by reference in the Contract Documents.

**3.3.** The Bidder, by submitting its electronic bid, agrees to and certifies under penalty of perjury under the laws of the State of California, that the certification, forms and affidavits submitted as part of this bid are true and correct.

**3.4.** The Bidder agrees to the construction of the project as described in Attachment "A-Scope of Work" for the City of San Diego, in accordance with the requirements set forth herein for the electronically submitted prices. The Bidder guarantees the Contract Price for a period of 120 days from the date of Bid opening. The duration of the Contract Price guarantee shall be extended by the number of days required for the City to obtain all items necessary to fulfill all conditions precedent.

**4. BIDS ARE PUBLIC RECORDS:** Upon receipt by the City, Bids shall become public records subject to public disclosure. It is the responsibility of the respondent to clearly identify any confidential, proprietary, trade secret or otherwise legally privileged information contained within the Bid. General references to sections of the California Public Records Act (PRA) will not suffice. If the Contractor does not provide applicable case law that clearly establishes that the requested information is exempt from the disclosure requirements of the PRA, the City shall be free to release the information when required in accordance with the PRA, pursuant

to any other applicable law, or by order of any court or government agency, and the Contractor will hold the City harmless for release of this information.

**5. CONTRACTOR REGISTRATION AND ELECTRONIC REPORTING SYSTEM:**

**5.1. Prior** to the Award of the Contract or Task Order, you and your Subcontractors and Suppliers must register with the City’s web-based vendor registration and bid management system. For additional information go to:

<http://www.sandiego.gov/purchasing/bids-contracts/vendorreg>

**5.2.** The City may not award the contract until registration of all subcontractors and suppliers is complete. In the event this requirement is not met within the time frame specified in the Notice of Intent to Award letter, the City reserves the right to rescind the Notice of Award / Intent to Award and to make the award to the next responsive and responsible bidder / proposer

**6. JOINT VENTURE CONTRACTORS:** Provide a copy of the Joint Venture agreement and the Joint Venture license to the City within 14 Calendar Days after receiving the Contract forms.

**7. INSURANCE REQUIREMENTS:**

**7.1.** All certificates of insurance and endorsements required by the contract are to be provided upon issuance of the City’s Notice of Intent to Award letter.

**7.2.** Refer to sections 5-4, “INSURANCE” of the Supplementary Special Provisions (SSP) for the insurance requirements which must be met.

**8. REFERENCE STANDARDS:** Except as otherwise noted or specified, the Work shall be completed in accordance with the following standards:

Title	Edition	Document Number
Standard Specifications for Public Works Construction (“The GREENBOOK”) <a href="http://www.greenbookspecs.org/">http://www.greenbookspecs.org/</a>	2021	ECPI010122-01
City of San Diego Standard Specifications for Public Works Construction (“The WHITEBOOK”)* <a href="https://www.sandiego.gov/ecp/edocref/greenbook">https://www.sandiego.gov/ecp/edocref/greenbook</a>	2021	ECPI010122-02
City of San Diego Standard Drawings* <a href="https://www.sandiego.gov/ecp/edocref/standarddraw">https://www.sandiego.gov/ecp/edocref/standarddraw</a>	2021	ECPI010122-03
Citywide Computer Aided Design and Drafting (CADD) Standards <a href="https://www.sandiego.gov/ecp/edocref/drawings">https://www.sandiego.gov/ecp/edocref/drawings</a>	2018	PWPI010119-04
California Department of Transportation (CALTRANS) Standard Specifications <a href="https://dot.ca.gov/programs/design/july-2023-ccs-standard-plans-and-standard-specifications">https://dot.ca.gov/programs/design/july-2023-ccs-standard-plans-and-standard-specifications</a>	2023	ECPD092023-05
CALTRANS Standard Plans	2023	ECPD092023-06

Title	Edition	Document Number
CALTRANS Standard Plans <a href="https://dot.ca.gov/programs/design/july-2023-ccs-standard-plans-and-standard-specifications">https://dot.ca.gov/programs/design/july-2023-ccs-standard-plans-and-standard-specifications</a>	2023	ECPD092023-06
California Manual on Uniform Traffic Control Devices Revision 7 (CA MUTCD Rev 7) <a href="https://dot.ca.gov/programs/safety-programs/camutcd">https://dot.ca.gov/programs/safety-programs/camutcd</a>	2014	ECPD081023-07
<b>NOTE:</b> *Available online under Engineering Documents and References at: <a href="https://www.sandiego.gov/ecp/edocref/">https://www.sandiego.gov/ecp/edocref/</a> *Electronic updates to the Standard Drawings may also be found in the link above		

- 9. CITY'S RESPONSES AND ADDENDA:** The City, at its discretion, may respond to any or all questions submitted in writing via the City's eBidding web site in the **form of an addendum**. No other responses to questions, oral or written shall be of any force or effect with respect to this solicitation. The changes to the Contract Documents through addenda are made effective as though originally issued with the Bid. The Bidders shall acknowledge the receipt of Addenda at the time of bid submission.
- 10. CITY'S RIGHTS RESERVED:** The City reserves the right to cancel the Notice Inviting Bids at any time, and further reserves the right to reject submitted Bids, without giving any reason for such action, at its sole discretion and without liability. Costs incurred by the Bidder(s) as a result of preparing Bids under the Notice Inviting Bids shall be the sole responsibility of each bidder. The Notice Inviting Bids creates or imposes no obligation upon the City to enter a contract.
- 11. CONTRACT PRICING:** This solicitation is for a Lump Sum contract with Unit Price provisions as set forth herein. The Bidder agrees to perform construction services for the City of San Diego in accordance with these contract documents for the prices listed below. The Bidder further agrees to guarantee the Contract Price for a period of 120 days from the date of Bid opening. The duration of the Contract Price guarantee may be extended, by mutual consent of the parties, by the number of days required for the City to obtain all items necessary to fulfill all contractual conditions.
- 12. SUBCONTRACTOR INFORMATION:**

**12.1. LISTING OF SUBCONTRACTORS.** In accordance with the requirements provided in the "Subletting and Subcontracting Fair Practices Act" of the California Public Contract Code, the Bidder shall provide the **NAME** and **ADDRESS** of each Subcontractor who will perform work, labor, render services or who specially fabricates and installs a portion [type] of the work or improvement, in an amount in excess of 0.5% of the Contractor's total Bid. The Bidder shall also state within the description, whether the subcontractor is a **CONSTRUCTOR, CONSULTANT** or **SUPPLIER**. The Bidder shall state the **DIR REGISTRATION NUMBER** for all subcontractors and shall further state within the description, the **PORION** of the work which will be performed by each subcontractor under this Contract. The Contractor shall list only one Subcontractor for each portion of the Work. The **DOLLAR VALUE** of the total Bid to be performed

shall be stated for all subcontractors listed. Failure to comply with this requirement may result in the Bid being rejected as **non-responsive** and ineligible for award. The Bidder's attention is directed to the Special Provisions – Section 3-2, "Self-Performance", which stipulates the percent of the Work to be performed with the Bidders' own forces. The Bidder shall list all SLBE, ELBE, DBE, DVBE, MBE, WBE, OBE, SDB, WoSB, HUBZone, and SDVOSB Subcontractors for which Bidders are seeking recognition towards achieving any mandatory, voluntary (or both) subcontracting participation goals.

Additionally, pursuant to California Senate Bill 96 and in accordance with the requirements of Labor Code sections 1771.1 and 1725.5, by submitting a bid or proposal to the City, Contractor is certifying that he or she has verified that all subcontractors used on this public work project are registered with the California Department of Industrial Relations (DIR). **The Bidder shall provide the name, address, license number, DIR registration number of any Subcontractor – regardless of tier** - who will perform work, labor, render services or specially fabricate and install a portion [type] of the work or improvement pursuant to the contract.

**12.2. LISTING OF SUPPLIERS.** Any Bidder seeking the recognition of Suppliers of equipment, materials, or supplies obtained from third party Suppliers towards achieving any mandatory or voluntary (or both) subcontracting participation goals shall provide, at a minimum, the **NAME, LOCATION (CITY), DIR REGISTRATION NUMBER** and the **DOLLAR VALUE** of each supplier. The Bidder will be credited up to 60% of the amount to be paid to the Suppliers for materials and supplies unless vendor manufactures or substantially alters materials and supplies, in which case, 100% will be credited. The Bidder is to indicate within the description whether the listed firm is a supplier or manufacturer. If no indication is provided, the listed firm will be credited at 60% of the listed dollar value for purposes of calculating the Subcontractor Participation Percentage.

**12.3. LISTING OF SUBCONTRACTORS OR SUPPLIERS FOR ALTERNATES.** For subcontractors or suppliers to be used on alternate items, bidder shall use the provided **"Subcontractors For Alternates"** form and shall indicate for each alternate subcontract whether it is an additive or deductive alternate; the subcontractor's name, location, phone number, email address, CA license number, and DIR registration number; whether the subcontractor is a designer, constructor or supplier; the type of work the subcontractor will be performing; and the dollar value of the subcontract for that alternate item. Failure to comply with this requirement may result in the bid being rejected as nonresponsive and ineligible for award.

**13. SUBMITTAL OF "OR EQUAL" ITEMS:** See Section 4-6, "Trade Names" in The WHITEBOOK and as amended in the SSP.

**14. AWARD:**

**14.1.** The Award of this contract is contingent upon the Contractor's compliance with all conditions precedent to Award.



- 14.2.** Upon acceptance of a Bid, the City will prepare contract documents for execution within approximately 21 days of the date of the Bid opening and award the Contract approximately within 7 days of receipt of properly executed Contract, bonds, and insurance documents.
- 14.3.** This contract will be deemed executed and effective only upon the signing of the Contract by the Mayor or his designee and approval as to form the City Attorney's Office.
- 15. SUBCONTRACT LIMITATIONS:** The Bidder's attention is directed to Standard Specifications for Public Works Construction, Section 3-2, "SELF-PERFORMANCE" in The GREENBOOK and as amended in the SSP which requires the Contractor to self-perform not less than the specified amount. Failure to comply with this requirement shall render the bid **non-responsive** and ineligible for award.
- 16. AVAILABILITY OF PLANS AND SPECIFICATIONS:** Contract Documents may be obtained by visiting the City's website: <http://www.sandiego.gov/cip/>. Plans and Specifications for this contract are also available for review in the office of the City Clerk or Purchasing & Contracting Department, Public Works Division.
- 17. ONLY ONE BID PER CONTRACTOR SHALL BE ACCEPTED:** No person, firm, or corporation shall be allowed to make, file, or be interested in more than one (1) Bid for the same work unless alternate Bids are called for. A person, firm or corporation who has submitted a sub-proposal to a Bidder, or who has quoted prices on materials to a Bidder, is not hereby disqualified from submitting a sub-proposal or quoting prices to other Bidders or from submitting a Bid in its own behalf. Any Bidder who submits more than one bid will result in the rejection of all bids submitted.
- 18. SAN DIEGO BUSINESS TAX CERTIFICATE:** The Contractor and Subcontractors, not already having a City of San Diego Business Tax Certificate for the work contemplated shall secure the appropriate certificate from the City Treasurer, Civic Center Plaza, First floor and submit to the Contract Specialist upon request or as specified in the Contract Documents. Tax Identification numbers for both the Bidder and the listed Subcontractors must be submitted on the City provided forms within these documents.
- 19. BIDDER'S GUARANTEE OF GOOD FAITH (BID SECURITY) FOR DESIGN-BID-BUILD CONTRACTS:**
- 19.1.** For bids \$250,000 and above, bidders shall submit Bid Security at bid time. Bid Security shall be in one of the following forms: a cashier's check, or a properly certified check upon some responsible bank; or an approved corporate surety bond payable to the City of San Diego for an amount of not less than 10% of the total bid amount.
- 19.2.** This check or bond, and the monies represented thereby, will be held by the City as a guarantee that the Bidder, if awarded the contract, will in good faith enter into the contract and furnish the required final performance and payment bonds.
- 19.3.** The Bidder agrees that in the event of the Bidder's failure to execute this contract and provide the required final bonds, the money represented by the cashier's or certified check will remain the property of the City; and the Surety agrees that it will pay to the City the damages, not exceeding the sum of 10% of the amount of the Bid, that the City may suffer as a result of such failure.

- 19.4. At the time of bid submission, bidders must upload and submit an electronic PDF copy of the aforementioned bid security. Whether in the form of a cashier's check, a properly certified check or an approved corporate surety bond payable to the City of San Diego, the bid security must be uploaded to the City's eBidding system. By 5PM, 1 working day after the bid opening date, all bidders must provide the City with the original bid security.
- 19.5. Failure to submit the electronic version of the bid security at the time of bid submission AND failure to provide the original by 5PM, 1 working day after the bid opening date shall cause the bid to be rejected and deemed **non-responsive**.

Original Bid Bond shall be submitted to:  
Purchasing & Contracting Department, Public Works Division  
1200 3rd Ave., Suite 200, MS 56P  
San Diego, California, 92101  
To the Attention of the Contract Specialist on the Front Page of this solicitation.

**20. AWARD OF CONTRACT OR REJECTION OF BIDS:**

- 20.1. This contract may be awarded to the lowest responsible and reliable Bidder.
- 20.2. Bidders shall complete ALL eBid forms as required by this solicitation. Incomplete eBids will not be accepted.
- 20.3. The City reserves the right to reject any or all Bids, to waive any informality or technicality in Bids received, and to waive any requirements of these specifications as to bidding procedure.
- 20.4. Bidders will not be released on account of their errors of judgment. Bidders may be released only upon receipt by the City within 3 Working Days of the bid opening, written notice from the Bidder which shows proof of honest, credible, clerical error of a material nature, free from fraud or fraudulent intent; and of evidence that reasonable care was observed in the preparation of the Bid.
- 20.5. A bidder who is not selected for contract award may protest the award of a contract to another bidder by submitting a written protest in accordance with the San Diego Municipal Code.
- 20.6. The City of San Diego will not discriminate in the award of contracts with regard to race, religion creed, color, national origin, ancestry, physical handicap, marital status, sex or age.
- 20.7. Each Bid package properly signed as required by these specifications shall constitute a firm offer which may be accepted by the City within the time specified herein.
- 20.8. The City reserves the right to evaluate all Bids and determine the lowest Bidder on the basis of the base bid and any proposed alternates or options as detailed herein.

**21. BID RESULTS:**

- 21.1. The availability of the bids on the City's eBidding system shall constitute the public announcement of the apparent low bidder. In the event that the apparent low bidder is subsequently deemed non-responsive or non-responsible, a notation of such will be

made on the eBidding system. The new ranking and apparent low bidder will be adjusted accordingly.

- 21.2.** To obtain the bid results, view the results on the City's web site, or request the results by U.S. mail and provide a self-addressed, stamped envelope. If requesting by mail, be sure to reference the bid name and number. The bid tabulations will be mailed to you upon their completion. The results will not be given over the telephone.

**22. THE CONTRACT:**

- 22.1.** The Bidder to whom award is made shall execute a written contract with the City of San Diego and furnish good and approved bonds and insurance certificates specified by the City within 14 days after receipt by Bidder of a form of contract for execution unless an extension of time is granted to the Bidder in writing.
- 22.2.** If the Bidder takes longer than 14 days to fulfill these requirements, then the additional time taken shall be added to the Bid guarantee. The Contract shall be made in the form adopted by the City, which includes the provision that no claim or suit whatsoever shall be made or brought by Contractor against any officer, agent, or employee of the City for or on account of anything done or omitted to be done in connection with this contract, nor shall any such officer, agent, or employee be liable hereunder.
- 22.3.** If the Bidder to whom the award is made fails to enter into the contract as herein provided, the award may be annulled and the Bidder's Guarantee of Good Faith will be subject to forfeiture. An award may be made to the next lowest responsible and reliable Bidder who shall fulfill every stipulation embraced herein as if it were the party to whom the first award was made.
- 22.4.** Pursuant to the San Diego City Charter section 94, the City may only award a public works contract to the lowest responsible and reliable Bidder. The City will require the Apparent Low Bidder to (i) submit information to determine the Bidder's responsibility and reliability, (ii) execute the Contract in form provided by the City, and (iii) furnish good and approved bonds and insurance certificates specified by the City within 14 Days, unless otherwise approved by the City, in writing after the Bidder receives notification from the City, designating the Bidder as the Apparent Low Bidder and formally requesting the above mentioned items.
- 22.5.** The award of the Contract is contingent upon the satisfactory completion of the above-mentioned items and becomes effective upon the signing of the Contract by the Mayor or designee and approval as to form by the City Attorney's Office. If the Apparent Low Bidder does not execute the Contract or submit required documents and information, the City may award the Contract to the next lowest responsible and reliable Bidder who shall fulfill every condition precedent to award. A corporation designated as the Apparent Low Bidder shall furnish evidence of its corporate existence and evidence that the officer signing the Contract and bond for the corporation is duly authorized to do so.

- 23. EXAMINATION OF PLANS, SPECIFICATIONS, AND SITE OF WORK:** The Bidder shall examine carefully the Project Site, the Plans and Specifications, other materials as described in the Special Provisions, Section 3-9, "TECHNICAL STUDIES AND SUBSURFACE DATA", and the proposal forms (e.g., Bidding Documents). The submission of a Bid shall be conclusive

evidence that the Bidder has investigated and is satisfied as to the conditions to be encountered, as to the character, quality, and scope of work, the quantities of materials to be furnished, and as to the requirements of the Bidding Documents Proposal, Plans, and Specifications.

**24. CITY STANDARD PROVISIONS:** This contract is subject to the following standard provisions. See The WHITEBOOK for details.

- 24.1.** The City of San Diego Resolution No. R-277952 adopted on May 20, 1991 for a Drug-Free Workplace.
- 24.2.** The City of San Diego Resolution No. R-282153 adopted on June 14, 1993 related to the Americans with Disabilities Act.
- 24.3.** The City of San Diego Municipal Code §22.3004 for Contractor Standards.
- 24.4.** The City of San Diego's Labor Compliance Program and the State of California Labor Code §§1771.5(b) and 1776.
- 24.5.** Sections 1777.5, 1777.6, and 1777.7 of the State of California Labor Code concerning the employment of apprentices by contractors and subcontractors performing public works contracts.
- 24.6.** The City's Equal Benefits Ordinance (EBO), Chapter 2, Article 2, Division 43 of The San Diego Municipal Code (SDMC).
- 24.7.** The City's Information Security Policy (ISP) as defined in the City's Administrative Regulation 90.63.

**25. PRE-AWARD ACTIVITIES:**

- 25.1.** The contractor selected by the City to execute a contract for this Work shall submit the required documentation as specified herein and in the Notice of Intent to Award. Failure to provide the information as specified may result in the Bid being rejected as **non-responsive**.
- 25.2.** The decision that bid is non-responsive for failure to provide the information required within the time specified shall be at the sole discretion of the City.

**PERFORMANCE BOND, LABOR AND MATERIALMEN'S BOND**  
**FAITHFUL PERFORMANCE BOND AND LABOR AND MATERIALMEN'S BOND:**

S.C. Valley Engineering, Inc. \_\_\_\_\_, a corporation, as principal, and  
Western Surety Company \_\_\_\_\_, a corporation authorized to do  
business in the State of California, as Surety, hereby obligate themselves, their successors and  
assigns, jointly and severally, to The City of San Diego a municipal corporation in the sum of  
**Seventeen Million Nine Hundred Fifteen Thousand Dollars and Zero Cents (\$17,915,000.00)**  
for the faithful performance of the annexed contract, and in the sum of **Seventeen Million**  
**Nine Hundred Fifteen Thousand Dollars and Zero Cents (\$17,915,000.00)** for the benefit of  
laborers and materialmen designated below.

**Conditions:**

If the Principal shall faithfully perform the annexed contract with the City of San Diego, California, then the obligation herein with respect to a faithful performance shall be void; otherwise it shall remain in full force.

If the Principal shall promptly pay all persons, firms and corporations furnishing materials for or performing labor in the execution of this contract, and shall pay all amounts due under the California Unemployment Insurance Act then the obligation herein with respect to laborers and materialmen shall be void; otherwise it shall remain in full force.

The obligation herein with respect to laborers and materialmen shall inure to the benefit of all persons, firms and corporations entitled to file claims under the provisions of Article 2. Claimants, (iii) public works of improvement commencing with Civil Code Section 9100 of the Civil Code of the State of California.

Changes in the terms of the annexed contract or specifications accompanying same or referred to therein shall not affect the Surety's obligation on this bond, and the Surety hereby waives notice of same.

The Surety shall pay reasonable attorney's fees should suit be brought to enforce the provisions of this bond.

The Surety expressly agrees that the City of San Diego may reject any contractor or subcontractor which may be proposed by Surety in fulfillment of its obligations in the event of default by the Principal.

The Surety shall not utilize the Principal in completing the improvements and work specified in the Agreement in the event the City terminates the Principal for default.

PERFORMANCE BOND, LABOR AND MATERIALMEN'S BOND (continued)

THE CITY OF SAN DIEGO

APPROVED AS TO FORM

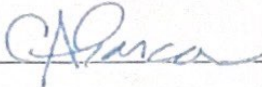
By: 

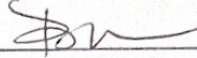
Mara W. Elliott, City Attorney  
By: 

Print Name: Claudia C. Abarca  
Director  
Purchasing & Contracting Department

Print Name: Bonny Han  
Deputy City Attorney

Date: May 30, 2024

Date: May 30, 2024

CONTRACTOR: S.C. Valley Engineering, Inc.

SURETY: Western Surety Company

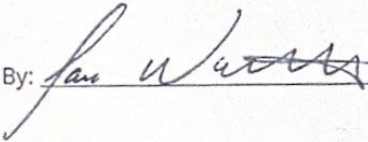
By: 

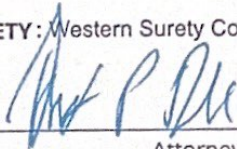
By:   
Attorney-In-Fact

Print Name: Sam Wertzman

Print Name: Robert P. Dole, Attorney-in-Fact

Date: 4/4/24

Date: 04/03/2024

P.O. Box 400, Bonita, CA 91908

Local Address of Surety

(619) 475-5200

Local Phone Number of Surety

\$96,343.00

Premium

30171623

Bond Number

# CALIFORNIA ALL-PURPOSE ACKNOWLEDGMENT

A notary public or other officer completing this certificate verifies only the identity of the individual who signed the document to which this certificate is attached, and not the truthfulness, accuracy, or validity of that document.

STATE OF CALIFORNIA

County of San Diego }

On April 3, 2024 before me, Patti Ewert, Notary Public,  
Date Insert Name of Notary exactly as it appears on the official seal

personally appeared Robert P. Dole  
Name(s) of Signer(s)

who proved to me on the basis of satisfactory evidence to be the person(s) whose name(s) is/are subscribed to the within instrument and acknowledged to me that he/she/they executed the same in his/her/their authorized capacity(ies), and that by his/her/their signature(s) on the instrument the person(s), or the entity upon behalf of which the person(s) acted, executed the instrument.

I certify under PENALTY OF PERJURY under the laws of the State of California that the foregoing paragraph is true and correct.

Witness my hand and official seal.

Signature Patti Ewert  
Signature of Notary Public, Patti Ewert



Place Notary Seal Above

## OPTIONAL

Though the information below is not required by law, it may prove valuable to persons relying on the document and could prevent fraudulent removal and reattachment of the form to another document.

### Description of Attached Document

Title or Type of Document: \_\_\_\_\_

Document Date: \_\_\_\_\_ Number of Pages: \_\_\_\_\_

Signer(s) Other Than Named Above: \_\_\_\_\_

### Capacity(ies) Claimed by Signer(s)

Signer's Name: Robert P. Dole

- Individual
- Corporate Officer — Title(s): \_\_\_\_\_
- Partner  Limited  General
- Attorney in Fact
- Trustee
- Guardian or Conservator
- Other: \_\_\_\_\_



Signer is Representing:  
\_\_\_\_\_  
\_\_\_\_\_  
\_\_\_\_\_

Signer's Name: \_\_\_\_\_

- Individual
- Corporate Officer — Title(s): \_\_\_\_\_
- Partner  Limited  General
- Attorney in Fact
- Trustee
- Guardian or Conservator
- Other: \_\_\_\_\_



Signer is Representing:  
\_\_\_\_\_  
\_\_\_\_\_  
\_\_\_\_\_

# Western Surety Company

## POWER OF ATTORNEY APPOINTING INDIVIDUAL ATTORNEY-IN-FACT

Know All Men By These Presents, That WESTERN SURETY COMPANY, a South Dakota corporation, is a duly organized and existing corporation having its principal office in the City of Sioux Falls, and State of South Dakota, and that it does by virtue of the signature and seal herein affixed hereby make, constitute and appoint

**Daniel P Dole, John T Dole, Robert P Dole, Adam Dole, Michael Dole, Patti Ewert, Individually**

of Bonita, CA, its true and lawful Attorney(s)-in-Fact with full power and authority hereby conferred to sign, seal and execute for and on its behalf bonds, undertakings and other obligatory instruments of similar nature

### - In Unlimited Amounts -

and to bind it thereby as fully and to the same extent as if such instruments were signed by a duly authorized officer of the corporation and all the acts of said Attorney, pursuant to the authority hereby given, are hereby ratified and confirmed.

This Power of Attorney is made and executed pursuant to and by authority of the Authorizing By-Laws and Resolutions printed at the bottom of this page, duly adopted, as indicated, by the shareholders of the corporation.

In Witness Whereof, WESTERN SURETY COMPANY has caused these presents to be signed by its Vice President and its corporate seal to be hereto affixed on this 16th day of January, 2024.



WESTERN SURETY COMPANY

*Larry Kasten*

Larry Kasten, Vice President

State of South Dakota }  
County of Minnehaha } ss

On this 16th day of January, 2024, before me personally came Larry Kasten, to me known, who, being by me duly sworn, did depose and say: that he resides in the City of Sioux Falls, State of South Dakota; that he is a Vice President of WESTERN SURETY COMPANY described in and which executed the above instrument; that he knows the seal of said corporation; that the seal affixed to the said instrument is such corporate seal; that it was so affixed pursuant to authority given by the Board of Directors of said corporation and that he signed his name thereto pursuant to like authority, and acknowledges same to be the act and deed of said corporation.

My commission expires  
March 2, 2026



*M. Bent*

M. Bent, Notary Public

### CERTIFICATE

I, Paula Kolsrud, Assistant Secretary of WESTERN SURETY COMPANY do hereby certify that the Power of Attorney hereinabove set forth is still in force, and further certify that the By-Law and Resolutions of the corporation printed below this certificate are still in force. In testimony whereof I have hereunto subscribed my name and affixed the seal of the said corporation this 03 day of April, 2024.



WESTERN SURETY COMPANY

*Paula Kolsrud*

Paula Kolsrud, Assistant Secretary

### Authorizing By-Laws and Resolutions

#### ADOPTED BY THE SHAREHOLDERS OF WESTERN SURETY COMPANY

This Power of Attorney is made and executed pursuant to and by authority of the following By-Law duly adopted by the shareholders of the Company.

Section 7. All bonds, policies, undertakings, Powers of Attorney, or other obligations of the corporation shall be executed in the corporate name of the Company by the President, Secretary, and Assistant Secretary, Treasurer, or any Vice President, or by such other officers as the Board of Directors may authorize. The President, any Vice President, Secretary, any Assistant Secretary, or the Treasurer may appoint Attorneys in Fact or agents who shall have authority to issue bonds, policies, or undertakings in the name of the Company. The corporate seal is not necessary for the validity of any bonds, policies, undertakings, Powers of Attorney or other obligations of the corporation. The signature of any such officer and the corporate seal may be printed by facsimile.

This Power of Attorney is signed by Larry Kasten, Vice President, who has been authorized pursuant to the above Bylaw to execute power of attorneys on behalf of Western Surety Company.

This Power of Attorney may be signed by digital signature and sealed by a digital or otherwise electronic-formatted corporate seal under and by the authority of the following Resolution adopted by the Board of Directors of the Company by unanimous written consent dated the 27<sup>th</sup> day of April, 2022:

“RESOLVED: That it is in the best interest of the Company to periodically ratify and confirm any corporate documents signed by digital signatures and to ratify and confirm the use of a digital or otherwise electronic-formatted corporate seal, each to be considered the act and deed of the Company.”

Go to [www.cnasurety.com](http://www.cnasurety.com) > Owner / Oblige Services > Validate Bond Coverage, if you want to verify bond authenticity.



## ATTACHMENTS

**ATTACHMENT A**  
**SCOPE OF WORK**

## SCOPE OF WORK

- SCOPE OF WORK:** Construction of Bay Ho Improvements 2 (Sewer & Water) consists of the installation of approximately 15,703 LF (2.97 miles) of 8-inch and 10-inch Sewer Mains, the rehabilitation of approximately 3,517 LF (0.67 miles) of Sewer Mains, the abandonment of approximately 7,501 LF (1.42 miles) of 8-inch and 15-inch VC Sewer Mains, the installation of approximately 7,543 LF (1.37 miles) of 8-inch and 12-inch Water Mains, and the abandonment of approximately 3,007 LF (0.57 miles) of 6-inch, 8-inch, and 12-inch AC Water Mains, including all associated water services, fire hydrants, laterals, manholes, replumbing, curb ramps, traffic control, trench restoration, pavement resurfacing, and all other work and appurtenances in accordance with these Specifications and Drawings .

**1.1.** The Work shall be performed in accordance with:

**1.1.1.** The Notice Inviting Bids and Plans numbered **42048-01-D** through **42048-93-D**, **42048-L1-D** through **42048-L3-D** and **42048-TC1** through **48048-TC13**, inclusive.

- LOCATION OF WORK:** The location of the Work is as follows:

See **Appendix E – Location Map**

- CONTRACT TIME:** The Contract Time for completion of the Work, including the Plant Establishment Period, shall be **939 Working Days**.

**ATTACHMENT B**  
**PHASED FUNDING PROVISIONS**

## PHASED FUNDING PROVISIONS

### 1. PRE-AWARD

- 1.1. Within 10 Working Days of the Notice of Intent to Award, the Contractor must contact the Project Manager to discuss fund availability for each phase and shall also submit the following:
  - 1.1.1. Construction Cost Loaded Schedule in accordance with 6-1, "CONSTRUCTION SCHEDULE AND COMMENCEMENT OF THE WORK" and 7-3, "PAYMENT".
- 1.2. Contractor's failure to perform any of the following may result cancelling the award of the Contract:
  - 1.2.1. Meeting with the City's Project Manager to discuss the Phased Funding Schedule.
  - 1.2.2. Agreeing to a Phased Funding Schedule within **thirty** days of meeting with the City's Project Manager.

### 2. POST-AWARD

- 2.1. Do not start any construction activities for the next phase until the Notice to Proceed (NTP) has been issued by the City. The City will issue a separate NTP for each phase.
- 2.2. The City may issue the NTP for a subsequent phase before the completion of the preceding phase.

## PHASED FUNDING SCHEDULE AGREEMENT

**BID NUMBER: K-24-2247-DBB-3**

**CONTRACT OR TASK TITLE: Bay Ho Improv 2**

**CONTRACTOR: S.C. Valley Engineering, Inc.**

Funding Phase	Phase Description	Phase Start	Phase Finish	Not-to-Exceed Amount
1	Work to be completed in Phase 1 shall include: bonds, mobilization, videotaping of existing conditions, 6,191 LF of sewer replacement on Sheets 3-12 and 455 LF of water main replacement on Sheets 31-32 in accordance with specifications and plans numbered 42048-01-D through 42048-93-D.	Notice to Proceed	04/30/2025	<b>B19106 (W)</b> <u>\$1,500,000.00</u> <b>B19104 (S)</b> <u>\$2,500,000.00</u> <i>Phase 1 Total=</i> <b>\$4,000,000.00</b>
2	Work to be completed in Phase 2 shall include 5,894 LF of sewer replacement on Sheets 13-22, 1,793 LF of sewer rehabilitation on Sheet 44, 4,615 LF of water main replacement on Sheets 33-40, and associated sewer abandonment and curb ramp installation in accordance with specifications and plans numbered 42048-01-D through 42048-93-D.	05/01/2025	04/30/2026	<b>B19106 (W)</b> <u>\$2,000,000.00</u> <b>B19104 (S)</b> <u>\$4,200,000.00</u> <i>Phase 2 Total=</i> <b>\$6,200,000.00</b>
3	Work to be completed in Phase 3 shall include 4,002 LF of sewer replacement on Sheets 23-30, 1076 LF of sewer rehabilitation on Sheet 45, 1,870 LF of water replacement on Sheets 41-43 and associated sewer abandonment, curb ramp installation, and street resurfacing in accordance with specifications and plans numbered 42048-01-D through 42048-93-D.	05/01/2026	04/30/2027	<b>B19106 (W)</b> <u>\$900,008.00</u> <b>B19104 (S)</b> <u>\$5,715,000.00</u> <b>Transportation</b> <u>\$500,000.00</u> <i>Phase 3 Total=</i> <b>\$7,115,008.00</b>
4	Work to be completed in Phase 4 shall include street resurfacing in accordance with specifications and plans numbered 42048-01-D through 42048-93-D.	05/01/2027	Notice of Completion	<b>Transportation</b> <u>\$599,992.00</u> <i>Phase 4 Total=</i> <b>\$599,992.00</b>

	Contract Total	Ph 1 \$ 4,000,000.00
		Ph 2 \$ 6,200,000.00
		Ph 3 \$ 7,115,008.00
		Ph 4 \$ 599,992.00
		<b>Total \$17,915,000.00</b>

**Notes:**

- 1) WHITEBOOK section 7-3.10, "Phased Funding Compensation" applies.
- 2) The total of all funding phases shall be equal to the TOTAL BID PRICE as shown on BID SCHEDULE 1 - PRICES.
- 3) This PHASED FUNDING SCHEDULE AGREEMENT will be incorporated into the CONTRACT and shall only be revised by written modifications to the CONTRACT.

**CITY OF SAN DIEGO**

PRINT NAME: Dino Lopez

**Construction Senior Engineer**

Signature: 

Date: 4/4/24

*for Nebit*

**CONTRACTOR**

PRINT NAME: Buzz Birney

Title: Project Manager

Signature: 

Date: 4/4/24

PRINT NAME: Jaime A. Ramos

**Design Senior Engineer**

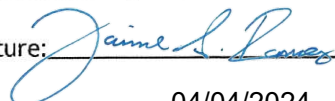
Signature: 

Date: 04/04/2024

**ATTACHMENT C**  
**EQUAL OPPORTUNITY CONTRACTING PROGRAM**



## EQUAL OPPORTUNITY CONTRACTING PROGRAM (EOCP)

### SECTION A - GENERAL REQUIREMENTS

#### A. INTRODUCTION.

1. This document sets forth the following specifications:
  - a) The City's general EOCP requirements for all Construction Contracts.
  - b) Special Provisions for Contracts subject to SLBE and ELBE requirements only.
2. Additional requirements may apply for state or federally funded projects.
3. These requirements shall be included as Contract provisions for all Subcontracts.
4. The City specified forms, instructions, and guides are available for download from the EOCP's web site at: <http://www.sandiego.gov/eoc/forms/index.shtml>

#### B. GENERAL.

1. The City of San Diego promotes equal employment and subcontracting opportunities.
2. The City is committed to ensuring that taxpayer dollars spent on public Contracts are not paid to businesses that practice discrimination in employment or subcontracting.
3. The City encourages all companies seeking to do business with the City to share this commitment.

#### C. DEFINITIONS.

1. For the purpose of these requirements: Terms "Bid" and "Proposal", "Bidder" and "Proposer", "Subcontractor" and "Subconsultant", "Contractor" and "Consultant", "Contractor" and "Prime Contractor", "Consultant" and "Professional Service Provider", "Suppliers" and "Vendors", "Suppliers" and "Dealers", and "Suppliers" and "Manufacturers" may have been used interchangeably.
2. The following definitions apply:
  - a) **Emerging Business Enterprise (EBE)** - A for-profit business that is independently owned and operated; that is not a subsidiary or franchise of another business and whose gross annual receipts do not exceed the amount set by the City Manager and that meets all other criteria set forth in regulations implementing Municipal Code Chapter 2, Article 2, Division 36. The City Manager shall review the threshold amount for EBEs on an annual basis and adjust as necessary to reflect changes in the marketplace.
  - b) **Emerging Local Business Enterprise (ELBE)** - A Local Business Enterprise that is also an Emerging Business Enterprise.

- c) **Minority Business Enterprise (MBE)** - A certified business that is at least fifty-one percent (51%) owned by one or more minority individuals, or, in the case of a publicly owned business at least fifty-one percent (51%) of the stock is owned by one or more minority individuals; and (2) whose daily business operations are managed and directed by one or more minorities owners. Minorities include the groups with the following ethnic origins: African, Asian Pacific, Asian Subcontinent, Hispanic, Native Alaskan, Native American, and Native Hawaiian.
- d) **Women Business Enterprise (WBE)** - A certified business that is at least fifty-one percent (51%) owned by a woman or women, or, in the case of a publicly owned business at least fifty-one percent (51%) of the stock is owned by one or more women; and (2) whose daily business operations are managed and directed by one or more women owners.
- e) **Disadvantaged Business Enterprise (DBE)** - a certified business that is at least fifty-one percent (51%) owned by socially and economically disadvantaged individuals, or, in the case of a publicly owned business at least fifty-one percent (51%) of the stock is owned by one or more socially and economically disadvantaged individuals; and (2) whose daily business operations are managed and directed by one or more socially and economically disadvantaged owners.
- f) **Disabled Veteran Business Enterprise (DVBE)** - A certified business that is at least fifty-one percent (51%) owned by one or more disabled veterans; and (2) business operations must be managed and controlled by one or more disabled veterans. Disabled Veteran is a veteran of the U.S. military, naval, or air service; the veteran must have a service-connected disability of at least 10% or more; and the veteran must reside in California.
- g) **Other Business Enterprise (OBE)** - Any business which does not otherwise qualify as a Minority, Woman, Disadvantaged, or Disabled Veteran Business Enterprise.
- h) **Small Business Enterprise (SBE)** - A for-profit business that is independently owned and operated; that is not a subsidiary or franchise of another business and whose gross annual receipts do not exceed the amount set by the City Manager and that meets all other criteria set forth in regulations implementing Municipal Code Chapter 2, Article 2, Division 36. The City Manager shall review the threshold amount for SBEs on an annual basis and adjust as necessary to reflect changes in the marketplace. A business certified as a Micro Business (MB) or a Disabled Veteran Business Enterprise (DVBE) by the State of California and that has provided proof of such certification to the City Manager shall be deemed to be an SBE.

- i) **Small Local Business Enterprise (SLBE)** - A Local Business Enterprise that is also a Small Business Enterprise.

**D. CITY'S EQUAL OPPORTUNITY COMMITMENT.**

**1. Nondiscrimination in Contracting Ordinance.**

- a) You, your Subcontractors, and Suppliers shall comply with the requirements of the City's Nondiscrimination in Contracting Ordinance, San Diego Municipal Code §§22.3501 through 22.3517.

You shall not discriminate on the basis of race, gender, gender expression, gender identity, religion, national origin, ethnicity, sexual orientation, age, or disability in the solicitation, selection, hiring, or treatment of subcontractors, vendors, or suppliers. You shall provide equal opportunity for Subcontractors to participate in subcontracting opportunities. You understand and agree that the violation of this clause shall be considered a material breach of the Contract and may result in Contract termination, debarment, or other sanctions.

You shall include the foregoing clause in all Contracts between you and your Subcontractors and Suppliers.

- b) **Disclosure of Discrimination Complaints.** As part of its Bid or Proposal, you shall provide to the City a list of all instances within the past 10 years where a complaint was filed or pending against you in a legal or administrative proceeding alleging that you discriminated against your employees, Subcontractors, vendors, or suppliers, and a description of the status or resolution of that complaint, including any remedial action taken.
- c) Upon the City's request, You agree to provide to the City, within 60 Calendar Days, a truthful and complete list of the names of all Subcontractors and Suppliers that you have used in the past 5 years on any of your Contracts that were undertaken within the San Diego County, including the total dollar amount paid by you for each Subcontract or supply Contract.
- d) You further agree to fully cooperate in any investigation conducted by the City pursuant to the City's Nondiscrimination in Contracting Ordinance, Municipal Code §§22.3501 through 22.3517. You understand and agree that violation of this clause shall be considered a material breach of the Contract and may result in remedies being ordered against you up to and including contract termination, debarment, and other sanctions for the violation of the provisions of the Nondiscrimination in Contracting Ordinance. You further understand and agree that the procedures, remedies, and sanctions provided for in the Nondiscrimination in Contracting Ordinance apply only to violations of the Ordinance.

**E. EQUAL EMPLOYMENT OPPORTUNITY OUTREACH PROGRAM.**

1. You, your Subcontractors, and Suppliers shall comply with the City's Equal Employment Opportunity Outreach Program, San Diego Municipal Code §§22.2701 through 22.2707.

You shall not discriminate against any employee or applicant for employment on any basis prohibited by law. You shall provide equal opportunity in all employment practices. You shall ensure that your Subcontractors comply with this program. Nothing in this section shall be interpreted to hold you liable for any discriminatory practices of your Subcontractors.

You shall include the foregoing clause in all Contracts between you and your Subcontractors and Suppliers.

2. If the Contract is competitively solicited, the selected Bidder shall submit a Work Force Report (Form BB05) within 10 Working Days after receipt by the Bidder to the City for approval as specified in the Notice of Intent to Award letter.
3. The selected Bidder shall submit an Equal Employment Opportunity Plan if a Work Force Report is submitted and if the City determines that there are under-representations when compared to County Labor Force Availability data.
4. If the selected Bidder submits an Equal Employment Opportunity Plan, it shall include the following assurances:
  - a) You shall maintain a working environment free of discrimination, harassment, intimidation, and coercion at all Sites and in all facilities at which your employees are assigned to Work.
  - b) You shall review your EEO Policy annually with all on-Site supervisors involved in employment decisions.
  - c) You shall disseminate and review your EEO Policy with all employees at least once a year, post the policy statement and EEO posters on all company bulletin boards and job sites, and document every dissemination, review, and posting with a written record to identify the time, place, employees present, subject matter, and disposition of meetings.
  - d) You shall review, at least annually, all supervisors' adherence to and performance under the EEO Policy and maintain written documentation of these reviews.
  - e) You shall discuss your EEO Policy Statement with Subcontractors with whom you anticipate doing business, including the EEO Policy Statement in your Subcontracts, and provide such documentation to the City upon request.

- f) You shall document and maintain a record of all Bid solicitations and outreach efforts to and from Subcontractors, contractor associations, and other business associations.
- g) You shall disseminate your EEO Policy externally through various media, including the media of people of color and women, in advertisements to recruit. Maintain files documenting these efforts and provide copies of these advertisements to the City upon request.
- h) You shall disseminate your EEO Policy to union and community organizations.
- i) You shall provide immediate written notification to the City when any union referral process has impeded your efforts to maintain your EEO Policy.
- j) You shall maintain a current list of recruitment sources, including those outreaching to people of color and women, and provide written notification of employment opportunities to these recruitment sources with a record of the organizations' responses.
- k) You shall maintain a current file of names, addresses and phone numbers of each walk-in applicant, including people of color and women, and referrals from unions, recruitment sources, or community organizations with a description of the employment action taken.
- l) You shall encourage all present employees, including people of color and women employees, to recruit others.
- m) You shall maintain all employment selection process information with records of all tests and other selection criteria.
- n) You shall develop and maintain documentation for on-the-job training opportunities, participate in training programs, or both for all of your employees, including people of color and women, and establish apprenticeship, trainee, and upgrade programs relevant to your employment needs.
- o) You shall conduct, at least annually, an inventory and evaluation of all employees for promotional opportunities and encourage all employees to seek and prepare appropriately for such opportunities.
- p) You shall ensure that the company's working environment and activities are non-segregated except for providing separate or single-user toilets and necessary changing facilities to assure privacy between the sexes.

**F. SUBCONTRACTING.**

1. The City encourages all eligible business enterprises to participate in City contracts as a Contractor, Subcontractor, and joint venture partner with you, your Subcontractors, or your Suppliers. You are encouraged to take positive steps to diversify and expand your Subcontractor solicitation base and to offer

subcontracting opportunities to all eligible business firms including SLBEs, ELBEs, MBEs, WBEs, DBEs, DVBES, and OBEs.

2. For Subcontractor participation level requirements, see the Contract Documents where applicable.
3. For the purposes of achieving the mandatory Subcontractor participation percentages, City percentage calculations will not account for the following:
  - a) "Field Orders" and "City Contingency" Bid items.
  - b) Alternate Bid items.
  - c) Allowance Bid items designated as "EOC Type II".
4. Allowance Bid items designated as "EOC Type I" will be considered as part of the Base Bid and will be included in the percentage calculation.
5. Each joint venture partner shall be responsible for a clearly defined Scope of Work. In addition, an agreement shall be submitted and signed by all parties identifying the extent to which each joint venture partner shares in ownership, control, management, risk, and profits of the joint venture.

**G. LISTS OF SUBCONTRACTORS AND SUPPLIERS.**

1. You shall comply with the Subletting and Subcontracting Fair Practices Act, Public Contract Code §§4100 through 4113, inclusive.
2. You shall list all Subcontractors who will receive more than 0.5% of the total Bid amount or \$10,000, whichever is greater on the form provided in the Contract Documents (Subcontractors list).
3. The Subcontractors list shall include the Subcontractor's name, telephone number including area code, physical address, Scope of Work, the dollar amount of the proposed Subcontract, the California contractor license number, the Public Works contractor registration number issued pursuant to Section 1725.5 of the Labor Code, and the Subcontractor's certification status with the name of the certifying agency.
4. The listed Subcontractor shall be appropriately licensed pursuant to Contractor License Laws.
5. For Design-Build Contracts, refer to the RFQ and RFP for each Project or Task Order.

**H. SUBCONTRACTOR AND SUPPLIER SUBSTITUTIONS.**

1. Listed Subcontractors and Suppliers shall not be substituted without the Express authorization of the City or its duly authorized agent.
2. Request for Subcontractor or Supplier substitution shall be made in writing to Purchasing & Contracting Department, Public Works Division, Attention Contract Specialist, 1200 3rd Ave., Suite 200, MS 56P, San Diego, CA 92101 with a copy to the Engineer.

3. The request shall include a thorough explanation of the reason(s) for the substitution, including dollar amounts and a letter from each substituted Subcontractor or Supplier stating that they (the Subcontractors or Suppliers) release all interest in working on the Project and written confirmation from the new Subcontractor or Supplier stating that they agree to work on the Project along with the dollar value of the Work to be performed.
4. Written approval of the substitution request shall be received by you or from the City or its authorized officer prior to any unlisted Subcontractor or Supplier performing Work on the Project.
5. Substitution of Subcontractors and Suppliers without authorization shall subject you to those penalties set forth in Public Contract Code §4110.
6. Requests for Supplier substitution shall be made in writing at least 10 Days prior to the provision of materials, supplies, or services by the proposed Supplier and shall include proof of written notice to the originally listed Supplier of the proposed substitution.
7. A Contractor whose Bid is accepted shall not:
  - a) Substitute a person as Subcontractor or Supplier in place of the Subcontractor or Supplier listed in the original bid, except that the City, or its duly authorized officer, may consent to the substitution of another person as a Subcontractor or Supplier in any of the following situations:
    - i. When the Subcontractor or Supplier listed in the Bid, after having a reasonable opportunity to do so, fails or refuses to execute a written Contract for the scope of work specified in the subcontractor's bid and at the price specified in the subcontractor's bid, when that written contract, based upon the general terms, conditions, plans, and specifications for the project involved or the terms of the subcontractor's written bid, is presented to the subcontractor by the prime contractor.
    - ii. When the listed Subcontractor or Supplier becomes insolvent or the subject of an order for relief in bankruptcy.
    - iii. When the listed Subcontractor or Supplier fails or refuses to perform his or her subcontract.
    - iv. When the listed Subcontractor fails or refuses to meet bond requirements as set forth in Public Contract Code §4108.
    - v. When you demonstrate to the City or its duly authorized officer, subject to the provisions set forth in Public Contract Code §4107.5, that the name of the Subcontractor was listed as the result of an inadvertent clerical error.
    - vi. When the listed Subcontractor is not licensed pursuant to Contractor License Law.

- vii. When the City, or its duly authorized officer, determines that the Work performed by the listed Subcontractor or that the materials or supplies provided by the listed Supplier are substantially unsatisfactory and not in substantial accordance with the Plans and specifications or that the Subcontractor or Supplier is substantially delaying or disrupting the progress of the Work.
  - viii. When the listed Subcontractor is ineligible to work on a public works project pursuant to §§1777.1 or 1777.7 of the Labor Code.
  - ix. When the City or its duly authorized agent determines that the listed Subcontractor is not a responsible contractor.
- b) Permit a Contract to be voluntarily assigned or transferred or allow it to be performed by anyone other than the original Subcontractor, Supplier listed in the original Bid without the consent of the City, or its duly authorized officer.
  - c) Other than in the performance of "Change Orders" causing changes or deviations from the Contract, sublet or subcontract any portion of the Work, or contract for materials or supplies in excess of 0.5% of your total bid or \$10,000, whichever is greater, as to which his or her original Bid did not designate a Subcontractor or Supplier.
8. Following receipt of notice from you of the proposed substitution of a Subcontractor or Supplier, the listed Subcontractor or Supplier who has been so notified shall have 5 Working Days within which to submit written objections to the substitution to the Contract Specialist with a copy to the Engineer. Failure to file these written objections shall constitute the listed Subcontractor or Supplier's consent to the substitution. If written objections are filed, the City shall give notice in writing of at least 5 Working Days to the listed Subcontractor or Supplier of a hearing by the City on your request for substitution.

**I. PROMPT PAYMENT.**

- 1. You or your Subcontractors shall pay to any subcontractor, not later than 7 Calendar Days of receipt of each progress payment, unless otherwise agreed to in writing, the respective amounts allowed you on account of the Work performed by the Subcontractors, to the extent of each Subcontractor's interest therein. In cases of Subcontractor performance deficiencies, you shall make written notice of any withholding to the Subcontractor with a copy to the Contracts Specialist. Upon correction of the deficiency, you shall pay the Subcontractor the amount previously withheld within 14 Calendar Days after payment by the City.
- 2. Any violation of California Business and Professions Code, §7108.5 concerning prompt payment to Subcontractors shall subject the violating Contractor or



Subcontractor to the penalties, sanctions, and other remedies of that section. This requirement shall not be construed to limit or impair any contractual, administrative, or judicial remedies otherwise available to you or your Subcontractor in the event of a dispute involving late payment or nonpayment by the Prime Contractor, deficient subcontract performance, or noncompliance by a Subcontractor.

**J. PROMPT PAYMENT OF FUNDS WITHHELD TO SUBCONTRACTORS.**

1. The City will hold retention from you and will make prompt and regular incremental acceptances of portions, as determined by the Engineer, of the Work and pay retention to you based on these acceptances.
2. You or your Subcontractors shall return all monies withheld in retention from a Subcontractor within 30 Calendar Days after receiving payment for Work satisfactorily completed and accepted including incremental acceptances of portions of the Work by the City.
3. Federal law (49CFR26.29) requires that any delay or postponement of payment over 30 Calendar Days may take place only for good cause and with the City's prior written approval. Any violation of this provision by you or your Subcontractor shall subject you or your Subcontractor to the penalties, sanctions, and other remedies specified in §7108.5 of the Business and Professions Code.
4. These requirements shall not be construed to limit or impair any contractual, administrative, or judicial remedies otherwise available to you or your Subcontractor in the event of a dispute involving late payment or nonpayment by you, deficient subcontract performance, or noncompliance by a Subcontractor.

**K. CERTIFICATION.**

1. The City accepts certifications of DBE, DVBE, MBE, SMBE, SWBE, or WBE by any of the following certifying agencies:
  - a) Current certification by the State of California Department of Transportation (CALTRANS) as DBE, SMBE, or SWBE.
  - b) Current MBE, WBE, or DVBE certification from the California Public Utilities Commission.
  - c) DVBE certification is received from the State of California's Department of General Services, Office of Small and Minority Business.
  - d) Current certification by the City of Los Angeles as DBE, WBE, or MBE.
  - e) Subcontractors' valid proof of certification status (copies of MBE, WBE, DBE, or DVBE certifications) shall be submitted as required.

**L. CONTRACT RECORDS AND REPORTS.**

1. You shall maintain records of all subcontracts and invoices from your Subcontractors and Suppliers for work on this project. Records shall show name, telephone number including area code, and business address of each Subcontractor, Supplier, and joint venture partner, and the total amount actually paid to each firm. Project relevant records, regardless of tier, may be periodically reviewed by the City.
2. You shall retain all records, books, papers, and documents pertinent to the Contract for a period of not less than 5 years after Notice of Completion and allow access to said records by the City's authorized representatives.
3. You shall submit the following reports using the City's web-based contract compliance (Prism® portal):
  - a. **Monthly Payment.** You shall submit Monthly Payment Reporting by the 10<sup>th</sup> day of the subsequent month. Incomplete and/or delinquent reporting may cause payment delays, non-payment of invoices, or both.
4. The records maintained under item 1, described above, shall be consolidated into a Final Summary Report, certified as correct by an authorized representative of the Contractor. The Final Summary Report shall include all subcontracting activities and be sent to the EOCP Program Manager prior to Acceptance. Failure to comply may result in assessment of liquidated damages or withholding of retention. The City will review and verify 100% of subcontract participation reported in the Final Summary Report prior to approval and release of final retention to you. In the event your Subcontractors are owed money for completed Work, the City may authorize payment to subcontractor via a joint check from the withheld retention.

## EQUAL OPPORTUNITY CONTRACTING PROGRAM (EOCP)

### SECTION B - SLBE-ELBE SUBCONTRACTING REQUIREMENTS

**THESE SPECIAL PROVISIONS SUPPLEMENT THE POLICIES AND REQUIREMENTS ESTABLISHED BY THE CITY OF SAN DIEGO EQUAL OPPORTUNITY CONTRACTING PROGRAM SPECIFIED IN THE CITY'S GENERAL EOCP REQUIREMENTS.**

#### **A. GENERAL.**

1. It is the City's policy to encourage greater availability, capacity development, and contract participation by SLBE and ELBE firms in City contracts. This policy is, in part, intended to further the City's compelling interest to stimulate economic development through the support and empowerment of the local community, ensure that it is neither an active nor passive participant in marketplace discrimination, and promote equal opportunity for all segments of the contracting community.
2. The City is committed to maximizing subcontracting opportunities for all qualified and available firms.
3. This policy applies to City-funded construction contracts. Bidders shall be fully informed of this policy as set forth in these specifications. Mandatory or voluntary subcontracting percentages, Bid Discounts, and restricted competitions are specified in the Contract Documents.
4. You shall make subcontracting opportunities available to a broad base of qualified Subcontractors and shall achieve the minimum SLBE-ELBE Subcontractor participation identified for your project.
5. Failure to subcontract the specified minimum (mandatory) percentages of the Bid to qualified available SLBE-ELBE Subcontractors will cause a Bid to be rejected as non-responsive unless the Bidder has demonstrated compliance with the affirmative steps as specified in the City's document titled "Small Local Business (SLBE) Program, INSTRUCTIONS FOR BIDDERS COMPLETING THE GOOD FAITH EFFORT SUBMITTAL" and has submitted documentation showing that all required positive efforts were made prior to the Bid submittal due date. The required Good Faith Effort (GFE) documentation shall be submitted to the Contract Specialist. The instructions for completing the good faith effort submittal can be found on the City's website:  
<https://www.sandiego.gov/sites/default/files/legacy/eoc/pdf/slbeinst.pdf>
6. The current list of certified SLBE-ELBE firms and information for completing the GFE submittal can be found on the City's EOC Department website:  
<http://www.sandiego.gov/eoc/programs/slbe.shtml>
7. These requirements may be waived, at the City's sole discretion, on projects deemed inappropriate for subcontracting participation.

## B.

### DEFINITIONS.

1. The following definitions shall be used in conjunction with these specifications:

- a) **Bid Discount** – Additional inducements or enhancements in the bidding process that are designed to increase the chances for the selection of SLBE firms in competition with other firms.
- b) **Commercially Useful Function** – An SLBE-ELBE performs a commercially useful function when it is responsible for the execution of the Work and is carrying out its responsibilities by actually performing, managing, and supervising the Work involved. To perform a commercially useful function, the SLBE-ELBE shall also be responsible, with respect to materials and supplies used on the Contract, for negotiating price, determining quantity and quality, ordering the material, and installing (where applicable) and paying for the material itself.

To determine whether an SLBE-ELBE is performing a commercially useful function, an evaluation will be performed of the amount of Work subcontracted, normal industry practices, whether the amount the SLBE-ELBE firm is to be paid under the contract is commensurate with the Work it is actually performing and the SLBE-ELBE credit claimed for its performance of the Work, and other relevant factors. Specifically, an SLBE-ELBE does not perform a commercially useful function if its role is limited to that of an extra participant in a transaction, contract, or project through which funds are passed in order to obtain the appearance of meaningful and useful SLBE-ELBE participation, when in similar transactions in which SLBE-ELBE firms do not participate, there is no such role performed.

- c) **Good Faith Efforts (GFE)** – Documentation of the Bidder's intent to comply with SLBE Program goals and procedures included in the City's SLBE Program, Instructions for Completing Good Faith Effort Submittal available from the City's EOCP website or the Contract Specialist.
- d) **Independently Owned, Managed, and Operated** – Ownership of a SLBE-ELBE firm shall be direct, independent, and by individuals only. Business firms that are owned by other businesses or by the principals or owners of other businesses that cannot themselves qualify under the SLBE-ELBE eligibility requirements shall not be eligible to participate in the Program. Moreover, the day-to-day management of the SLBE-ELBE firm shall be direct and independent of the influence of any other businesses that cannot themselves qualify under the SLBE-ELBE eligibility requirements.
- e) **Joint Venture** – An association of two or more persons or business entities that is formed for the single purpose of carrying out a single defined business enterprise for which purpose they combine their

capital, efforts, skills, knowledge, or property. Joint ventures shall be established by written agreement to qualify for this program.

- f) **Local Business Enterprise (“LBE”)** – A firm having a Principal Place of Business and a Significant Employment Presence in San Diego County, California that has been in operation for 12 consecutive months and a valid business tax certificate. This definition is subsumed within the definition of Small Local Business Enterprise.
- g) **Minor Construction Program** – A program developed for bidding exclusively among SLBE-ELBE Construction firms.
- h) **Principal Place of Business** – A location wherein a firm maintains a physical office and through which it obtains no less than 50% of its overall customers or sales dollars.
- i) **Protégé** – A firm that has been approved and is an active participant in the City’s Mentor-Protégé Program and that has signed the required program participation agreement and has been assigned a mentor.
- j) **Significant Employee Presence** – No less than 25% of a firm’s total number of employees are domiciled in San Diego County.

**C. SUBCONTRACTOR PARTICIPATION.**

- 1. For the purpose of satisfying subcontracting participation requirements, only 1<sup>st</sup> tier SLBE–ELBE Subcontractors will be recognized as participants in the Contract according to the following criteria:
  - a) For credit to be allowed toward a respective participation level, all listed SLBE-ELBE firms shall have been certified by the Bid due date.
  - b) The Subcontractor shall perform a commercially useful function for credit to be allowed toward subcontractor participation levels. The Subcontractor shall be required by you to be responsible for the execution of a distinct element of the Work and shall carry out its responsibility by actually performing and supervising its own workforce.
  - c) If the Bidder is seeking the recognition of materials, supplies, or both towards achieving any mandatory subcontracting participation level, the Bidder shall indicate on Form AA40 – Named Equipment/Material Supplier List with the Bid the following:
    - i. If the materials or supplies are obtained from a SLBE-ELBE manufacturer, the Bidder will receive 100% of the cost of the materials or supplies toward SLBE participation. For the purposes of counting SLBE-ELBE participation, a manufacturer is a firm that operates or maintains a factory or establishment that produces, on the premises, the materials, supplies, articles, or equipment required under the Contract and of the general character described by the specifications.

- ii. If the materials or supplies are obtained from a SLBE-ELBE supplier, the Bidder will receive 60% of the cost of the materials or supplies toward SLBE participation. For the purposes of counting SLBE-ELBE participation a Supplier is a firm that owns, operates, or maintains a store, warehouse, or other establishment in which the materials, supplies, articles or equipment of the general character described by the specifications and required under the Contract are bought, kept in stock, and regularly sold or leased to the public in the usual course of business. To be a supplier, the firm shall be an established, regular business that engages, as its principal business and under its own name, in the purchase and sale or lease of the products in question. A person may be a supplier in such bulk items as petroleum products, steel, cement, gravel, stone, or asphalt without owning, operating, or maintaining a place of business if the person both owns and operates distribution equipment for the products. Any supplementing of the suppliers' own distribution equipment shall be by a long-term lease agreement and shall not be on an ad hoc or contract-by-contract basis.
  - iii. If the materials or supplies are obtained from a SLBE-ELBE, which is neither a manufacturer nor a supplier, the entire amount of fees or commissions charged for assistance in the procurement of the materials and supplies, fees or transportation charges for the delivery of materials or supplies required on a job site will be counted toward SLBE-ELBE participation, provided the fees are reasonable and not excessive as compared with fees customarily allowed for similar services. No portion of the cost of the materials and supplies themselves will be counted toward SLBE-ELBE participation.
- d) If the Bidder is seeking the recognition of SLBE-ELBE Trucking towards achieving any mandatory subcontracting participation level, the Bidder shall indicate it on Form AA35 - List of Subcontractors with the Bid. The following factors will be evaluated in determining the credit to be allowed toward the respective participation level:
- i. The SLBE-ELBE shall be responsible for the management and supervision of the entire trucking operation for which it is getting credit on a particular Contract and there shall not be a contrived arrangement for the purpose of counting SLBE-ELBE participation.
  - ii. The SLBE-ELBE shall itself own and operate at least 1 fully licensed, insured, and operational truck used on the Contract.

- iii. The SLBE-ELBE receives credit for the total value of the transportation services it provides on the Contract using trucks it owns, insures, and operates using drivers it employs.
- iv. The SLBE-ELBE may lease trucks from another SLBE-ELBE firm including an owner-operator who is certified as a SLBE-ELBE. The SLBE-ELBE who leases trucks from another SLBE-ELBE receives credit for the total value of the transportation services the lessee SLBE-ELBE provides on the contract.
- v. The SLBE-ELBE may also lease trucks from a non-SLBE-ELBE firm, including an owner-operator. The SLBE-ELBE who leases trucks from a non-SLBE-ELBE is entitled to credit for the total value of transportation services provided by non-SLBE-ELBE lessees not to exceed the value of transportation services provided by SLBE-ELBE owned trucks on the contract. Additional participation by non-SLBE-ELBE lessees receive credit only for the fee or commission it receives as a result of the lease arrangement.
- vi. A lease shall indicate that the SLBE-ELBE has exclusive use of and control over the truck. This does not preclude the leased truck from working for others during the term of the lease with the consent of the SLBE-ELBE so long as the lease gives the SLBE-ELBE absolute priority for use of the leased truck.

**D. SLBE-ELBE SUBCONTRACTOR PARTICIPATION PERCENTAGES.**

1. Contracts valued at \$1,500,000 and above will be considered Major Public Works Contracts and will include a mandatory Subcontractor participation requirement for SLBE-ELBE firms.
  - a) The Bidder shall achieve the mandatory Subcontractor participation requirement or demonstrate GFE.
  - b) The Bidders shall indicate the participation on Forms AA35 - List of Subcontractors and AA40 - Named Equipment/Material Supplier List as applicable regardless of the dollar value.
  - c) An SLBE-ELBE Bidder may count its own participation toward achieving the mandatory goal as long as the SLBE-ELBE Bidder performs 51% of the Contract Price.
- 2.. Contracts Valued over \$1,000,000 and under \$1,500,000 will also be considered Major Public Works Contracts and will include the mandatory subcontractor participation requirements described above and the following:
  - a) 5% bid discount for SLBE-ELBE firms.
  - b) Non-certified Contractor will receive 5% bid discount if they achieve the specified mandatory Subcontracting participations.
  - c) Bid discounts shall not apply if the award will result in a total contract cost of \$50,000 in excess of the apparent lowest Bid.

- d) In the event of a tie bid between a SLBE-ELBE Bidder and a non-SLBE-ELBE Bidder, the SLBE-ELBE Bidder will be awarded the Contract.
  - e) In the event of a tie bid between a discounted Bid and a non-discounted Bid, the discounted Bid will be awarded the Contract.
- 3. Contracts valued over \$500,000 up to \$1,000,000 will be considered Minor Public Works Contracts and will be awarded through a competitive Bid process open only to City certified SLBE-ELBE firms. If there are no bidders or no responsible bidders, the Contract will be made available to all Bidders and will be subject to requirements listed in items 1 and 2 for Major Public Works Contracts above.
  - 4. Contracts valued at \$500,000 and below will also be considered Minor Public Works Contracts and will be awarded through a competitive bid process open only to City certified ELBEs unless there are less than 2 firms available at which it will be awarded through a competitive process open only to the City certified SLBE-ELBE firms. If there are no bidders or no responsible bidders, the Contract will be made available to all Bidders and subject to requirements listed in items 1 and 2 for Major Public Works Contracts above.

**E. JOINT VENTURES.**

- 1. The City may allow for Joint Venture bid discounts on some Contracts. Contracts that allow for Joint Venture bid discounts will be designated in Bid documents. A firm that is bidding or competing for City Contracts may partner with a certified SLBE or ELBE to compete for Contracts as a Joint Venture.
- 2. A Joint Venture shall be between two entities with the same discipline or license as required by the City. Joint ventures will receive bid discounts depending on the SLBE or ELBE percentage of participation. To be eligible for a discount, a Joint Venture Agreement shall be approved by the City at the time of Bid submittal. The maximum allowable discount shall be 5%. The parties shall agree to enter in the relationship for the life of the projects.
- 3. Joint Venture shall submit a Joint Venture Management Plan, a Joint Venture Agreement, or both at least 2 weeks prior to the Bid due date. Copies of the Joint Venture applications are available upon request to the Contract Specialist. Each agreement or management plan shall include the following:
  - a) Detailed explanation of the financial contribution for each partner.
  - b) List of personnel and equipment used by each partner.
  - c) Detailed breakdown of the responsibilities of each partner.
  - d) Explanation of how the profits and losses will be distributed.
  - e) Description of the bonding capacity of each partner.
  - f) Management or incentive fees available for any one of the partners (if any).



4. Each Joint Venture partner shall perform a Commercially Useful Function. An SLBE or ELBE that relies on the resources and personnel of a non-SLBE or ELBE firm will not be deemed to perform a Commercially Useful Function.
5. Each Joint Venture partner shall possess licenses appropriate for the discipline for which a proposal is being submitted. If a Joint Venture is bidding on a single trade project, at the time of bid submittal, each Joint Venture partner shall possess the requisite specialty license for that trade bid.
6. The SLBE or ELBE partner shall clearly define the portion of the Work to be performed. This Work shall be of the similar type of Work the SLBE or ELBE partner performs in the normal course of its business. The Joint Venture Participation Form shall specify the Bid items to be performed by each individual Joint Venture partner. Lump sum Joint Venture participation shall not be acceptable.
7. Responsibilities of the SLBE or ELBE Joint Venture Partner:
  - a) The SLBE or ELBE partner shall share in the control, management responsibilities, risks and profits of the Joint Venture in proportion with the level of participation in the project.
  - b) The SLBE or ELBE partner shall perform Work that is commensurate with its experience.
  - c) The SLBE or ELBE partner shall use its own employees and equipment to perform its portion of the Work.
  - d) The Joint Venture as a whole shall perform Bid items that equal or exceed 50% of the Contract Price, excluding the cost of manufactured items, in order to be eligible for a Joint Venture discount.

**F. MAINTAINING PARTICIPATION LEVELS.**

1. Credit and preference points are earned based on the level of participation proposed prior to the award of the Contract. Once the Project begins you shall achieve and maintain the SLBE-ELBE participation levels for which credit and preference points were earned. You shall maintain the SLBE-ELBE percentages indicated at the Award of Contract and throughout the Contract Time.
2. If the City modifies the original Scope of Work, you shall make reasonable efforts to maintain the SLBE-ELBE participation for which creditor preference points were earned. If participation levels will be reduced, approval shall be received from the City prior to making changes.
3. You shall notify and obtain written approval from the City in advance of any reduction in subcontract scope, termination, or substitution for a designated SLBE-ELBE Subcontractor. Failure to do so shall constitute a material breach of the Contract.
4. If you fail to maintain the SLBE-ELBE participation listed at the time the Contract is awarded and have not received prior approval from the City, the

City may declare you in default and will be considered grounds for debarment under Chapter 2, Article 2, Division 8, of the San Diego Municipal Code.

**G. SUBCONTRACTING EFFORTS REVIEW AND EVALUATION.**

1. Documentation of your subcontracting efforts will be reviewed by EOCP to verify that you made subcontracting opportunities available to a broad base of qualified Subcontractors, negotiated in good faith with interested Subcontractors, and did not reject any bid for unlawful discriminatory reasons. The EOCP review is based on the federal “Six Good Faith Efforts” model.
2. The GFEs are required methods to ensure that all ELBE and SLBE firms have had the opportunity to compete for the City’s Public Works procurements. The Six Good Faith Efforts, also known as affirmative steps, attract and utilize ELBE and SLBE firms:
  - a) Ensure ELBE firms are made aware of contracting opportunities to the fullest extent practicable through outreach and recruitment activities.
  - b) Make information of forthcoming opportunities available to SLBE-ELBE firms and arrange time for Contracts and establish delivery schedules, where requirements permit, in a way that encourages and facilitates participation by SLBE-ELBE firms in the competitive process. This includes posting solicitations for Bids or proposals to SLBE-ELBE firms for a minimum of 10 Working Days before the Bid or Proposal due date.
  - c) Consider in the contracting process whether firms competing for large Contracts could subcontract with SLBE-ELBE firms.
  - d) Encourage contracting with a consortium of ELBE-SLBE firms when a Contract is too large for one of these firms to handle individually.
  - e) Use the services and assistance of the City’s EOC Office and the SLBE-ELBE Directory.
  - f) If you award subcontracts, require your Subcontractors to take the steps listed above.

**H. GOOD FAITH EFFORT DOCUMENTATION.**

1. If the specified SLBE-ELBE Subcontractor participation percentages are not met, you shall submit information necessary to establish that adequate GFEs were taken to meet the Contract Subcontractor participation percentages. See the City’s document titled “Small Local Business (SLBE) Program, INSTRUCTIONS FOR BIDDERS COMPLETING THE GOOD FAITH EFFORT SUBMITTAL.” The instructions for completing the good faith effort submittal can be found on the City’s website:

<https://www.sandiego.gov/sites/default/files/legacy/eoc/pdf/slbegfeinst.pdf>

**I. SUBCONTRACTOR SUBSTITUTION.**

1. Evidence of fraud or discrimination in the substitution of Subcontractors will result in sanctions including assessment of penalty fines, termination of Contract, or debarment. This section does not replace applicable California Public Contract Code.

**J. FALSIFICATION OF SUB-AGREEMENT AND FRAUD.**

1. Falsification or misrepresentation of a sub-agreement as to company name, Contract amount or actual Work performed by Subcontractors, or any falsification or fraud on the part your submission of documentation and forms pursuant to this program, will result in sanctions against you including assessment of penalty fines, termination of the Contract, or debarment. Instances of falsification or fraud which are indicative of an attempt by you to avoid subcontracting with certain categories of Subcontractors on the basis of race, gender, gender expression, gender identity, religion, national origin, ethnicity, sexual orientation, age, or disability shall be referred to the Equal Opportunity Contracting Program's Investigative Unit for possible violations of Article 2, Division 35 of the City Administrative Code, §§22.3501 et seq. (Nondiscrimination in Contracting).

**K. RESOURCES.**

1. The current list of certified SLBE-ELBE firms and information for completing the GFE submittal can be found on the City's EOC Department website:  
<http://www.sandiego.gov/eoc/programs/slbe.shtml>
-

**ATTACHMENT D**  
**PREVAILING WAGE**

## PREVAILING WAGE

1. **PREVAILING WAGE RATES:** Pursuant to San Diego Municipal Code section 22.3019, construction, alteration, demolition, repair and maintenance work performed under this Contract is subject to State prevailing wage laws. For construction work performed under this Contract cumulatively exceeding \$25,000 and for alteration, demolition, repair and maintenance work performed under this Contract cumulatively exceeding \$15,000, the Contractor and its subcontractors shall comply with State prevailing wage laws including, but not limited to, the requirements listed below.
  - 1.1. **Compliance with Prevailing Wage Requirements.** Pursuant to sections 1720 through 1861 of the California Labor Code, the Contractor and its subcontractors shall ensure that all workers who perform work under this Contract are paid not less than the prevailing rate of per diem wages as determined by the Director of the California Department of Industrial Relations (DIR). This includes work performed during the design and preconstruction phases of construction including, but not limited to, inspection and land surveying work.
    - 1.1.1. Copies of such prevailing rate of per diem wages are on file at the City and are available for inspection to any interested party on request. Copies of the prevailing rate of per diem wages also may be found at <http://www.dir.ca.gov/OPRL/DPreWageDetermination.htm>. Contractor and its subcontractors shall post a copy of the prevailing rate of per diem wages determination at each job site and shall make them available to any interested party upon request.
    - 1.1.2. The wage rates determined by the DIR refer to expiration dates. If the published wage rate does not refer to a predetermined wage rate to be paid after the expiration date, then the published rate of wage shall be in effect for the life of this Contract. If the published wage rate refers to a predetermined wage rate to become effective upon expiration of the published wage rate and the predetermined wage rate is on file with the DIR, such predetermined wage rate shall become effective on the date following the expiration date and shall apply to this Contract in the same manner as if it had been published in said publication. If the predetermined wage rate refers to one or more additional expiration dates with additional predetermined wage rates, which expiration dates occur during the life of this Contract, each successive predetermined wage rate shall apply to this Contract on the date following the expiration date of the previous wage rate. If the last of such predetermined wage rates expires during the life of this Contract, such wage rate shall apply to the balance of the Contract.
  - 1.2. **Penalties for Violations.** Contractor and its subcontractors shall comply with California Labor Code section 1775 in the event a worker is paid less than the prevailing wage rate for the work or craft in which the worker is employed. This shall be in addition to any other applicable penalties allowed under Labor Code sections 1720 – 1861.

- 1.3. Payroll Records.** Contractor and its subcontractors shall comply with California Labor Code section 1776, which generally requires keeping accurate payroll records, verifying and certifying payroll records, and making them available for inspection. Contractor shall require its subcontractors to also comply with section 1776. Contractor and its subcontractors shall submit weekly certified payroll records online via the City's web-based Labor Compliance Program. Contractor is responsible for ensuring its subcontractors submit certified payroll records to the City.

  - 1.3.1.** Contractor and their subcontractors shall also furnish records specified in Labor Code section 1776 directly to the Labor Commissioner in the manner required by Labor Code section 1771.4.
- 1.4. Apprentices.** Contractor and its subcontractors shall comply with California Labor Code sections 1777.5, 1777.6 and 1777.7 concerning the employment and wages of apprentices. Contractor is held responsible for the compliance of their subcontractors with sections 1777.5, 1777.6 and 1777.7.
- 1.5. Working Hours.** Contractor and their subcontractors shall comply with California Labor Code sections 1810 through 1815, including but not limited to: (i) restrict working hours on public works contracts to eight hours a day and forty hours a week, unless all hours worked in excess of 8 hours per day are compensated at not less than 1½ times the basic rate of pay; and (ii) specify penalties to be imposed on contractors and subcontractors of \$25 per worker per day for each day the worker works more than 8 hours per day and 40 hours per week in violation of California Labor Code sections 1810 through 1815.
- 1.6. Required Provisions for Subcontracts.** Contractor shall include at a minimum a copy of the following provisions in any contract they enter into with a subcontractor: California Labor Code sections 1771, 1771.1, 1775, 1776, 1777.5, 1810, 1813, 1815, 1860 and 1861.
- 1.7. Labor Code Section 1861 Certification.** Contractor in accordance with California Labor Code section 3700 is required to secure the payment of compensation of its employees and by signing this Contract, Contractor certifies that "I am aware of the provisions of Section 3700 of the California Labor Code which require every employer to be insured against liability for workers' compensation or to undertake self-insurance in accordance with the provisions of that code, and I will comply with such provisions before commencing the performance of the work of this Contract."
- 1.8. Labor Compliance Program.** The City has its own Labor Compliance Program authorized in August 2011 by the DIR. The City will withhold contract payments when payroll records are delinquent or deemed inadequate by the City or other governmental entity, or it has been established after an investigation by the City or other governmental entity that underpayment(s) have occurred. For questions or assistance, please contact the City of San Diego's Prevailing Wage Unit at 858-627-3200.

- 1.9. Contractor and Subcontractor Registration Requirements.** This project is subject to compliance monitoring and enforcement by the DIR. A contractor or subcontractor shall not be qualified to bid on, be listed in a bid or proposal, subject to the requirements of section 4104 of the Public Contract Code, or engage in the performance of any contract for public work, unless currently registered and qualified to perform public work pursuant to Labor Code section 1725.5. It is not a violation of this section for an unregistered contractor to submit a bid that is authorized by Section 7029.1 of the Business and Professions code or by Section 10164 or 20103.5 of the Public Contract Code, provided the contractor is registered to perform public work pursuant to Section 1725.5 at the time the contract is awarded.
- 1.9.1.** A Contractor's inadvertent error in listing a subcontractor who is not registered pursuant to Labor Code section 1725.5 in response to a solicitation shall not be grounds for filing a bid protest or grounds for considering the bid non-responsive provided that any of the following apply: (1) the subcontractor is registered prior to bid opening; (2) within twenty-four hours after the bid opening, the subcontractor is registered and has paid the penalty registration fee specified in Labor Code section 1725.5; or (3) the subcontractor is replaced by another registered subcontractor pursuant to Public Contract Code section 4107.
- 1.9.2.** By submitting a bid or proposal to the City, Contractor is certifying that he or she has verified that all subcontractors used on this public work project are registered with the DIR in compliance with Labor Code sections 1771.1 and 1725.5, and Contractor shall provide proof of registration for themselves and all listed subcontractors to the City at the time of bid or proposal due date or upon request.
- 1.10. Stop Order.** For Contractor or its subcontractors engaging in the performance of any public work contract without having been registered in violation of Labor Code sections 1725.5 or 1771.1, the Labor Commissioner shall issue and serve a stop order prohibiting the use of the unregistered contractors or unregistered subcontractor(s) on ALL public works until the unregistered contractor or unregistered subcontractor(s) is registered. Failure to observe a stop order is a misdemeanor.
- 1.11. List of all Subcontractors.** The Contractor shall provide the list of subcontractors (regardless of tier), along with their DIR registration numbers, utilized on this Contract prior to any work being performed; and the Contractor shall provide a complete list of all subcontractors with each invoice. Additionally, Contractor shall provide the City with a complete list of all subcontractors (regardless of tier) utilized on this contract within ten working days of the completion of the contract, along with their DIR registration numbers. The City shall withhold final payment to Construction Management Professional until at least thirty (30) days after this information is provided to the City.
- 1.12. Exemptions for Small Projects.** There are limited exemptions for installation, alteration, demolition, or repair work done on projects of \$25,000 or less. The Contractor shall still comply with Labor Code sections 1720 et. seq. The only recognized exemptions are listed below:

- 1.12.1.** Registration. The Contractor will not be required to register with the DIR for small projects. (Labor Code section 1771.1).
- 1.12.2.** Certified Payroll Records. The records required in Labor Code section 1776 shall be required to be kept and submitted to the City of San Diego, but will not be required to be submitted online with the DIR directly. The Contractor will need to keep those records for at least three years following the completion of the Contract. (Labor Code section 1771.4).
- 1.12.3.** List of all Subcontractors. The Contractor shall not be required to hire only registered subcontractors and is exempt from submitting the list of all subcontractors that is required in section 1.11. above. (Labor code section 1773.3).



**ATTACHMENT E**  
**SUPPLEMENTARY SPECIAL PROVISIONS**

## SUPPLEMENTARY SPECIAL PROVISIONS

The following Supplementary Special Provisions (SSP) modifies the following documents:

1. The **2021 Edition** of the Standard Specifications for Public Works Construction (The "GREENBOOK").
2. The **2021 Edition** of the City of San Diego Standard Specifications for Public Works Construction (The "WHITEBOOK"), including the following:
  - a) General Provisions (A) for all Construction Contracts.

---

### SECTION 1 – GENERAL, TERMS, DEFINITIONS, ABBREVIATIONS, UNITS OF MEASURE, AND SYMBOLS

**1-2 TERMS AND DEFINITIONS.** To the "WHITEBOOK":

To item 47, "Holiday", ADD the following:

<b>Holiday</b>	<b>Observed On</b>
Juneteenth	June 19

To item 55, "Normal Working Hours", DELETE in its entirety and SUBSTITUTE with the following:

**Normal Working Hours:** Normal Working Hours shall be **7:30 AM to 3:30 PM, Monday through Friday**, inclusive. Saturdays, Sundays, and City Holidays are excluded. Unless otherwise specified on the Traffic Control Permits.

### SECTION 3 – CONTROL OF THE WORK

**3-2 SELF-PERFORMANCE.** To the "GREENBOOK", DELETE in its entirety and SUBSTITUTE with the following:

1. You shall perform, with your own organization, Contract Work amounting to at least **50%** of the Base Bid.

**3-8.4 Supporting Information.** To the "WHITEBOOK", ADD the following:

4. You shall collect and submit rehabilitation data spreadsheets along with monthly invoices for the following rehabilitation Work (see **Appendix J – Rehabilitation Data Collection – Sample Sewer Mains, Laterals, Manholes Data Templates**).
  - a) Laterals
  - b) Sewer Mains
  - c) Manholes

**3-8.7 Contractor's Quality Control Plan (QCP).** To the "WHITEBOOK", ADD the following:

7. The establishment and implementation of a Quality Control Plan (QCP), as defined in the standard specifications, shall be required for this Contract. See example in **Appendix G - Sample Contractor's Daily Quality Control Inspection Report.**

**3-9 TECHNICAL STUDIES AND SUBSURFACE DATA.** To the "WHITEBOOK", ADD the following:

5. In preparation of the Contract Documents, the designer has relied upon the following reports of explorations and tests at the Work Site:
  - a) Report of Geotechnical Investigation Bay Ho Improv 2 Project, dated July 3, 2022 (Updated August 23, 2022) by Allied Geotechnical Engineers, INC.
  - b) Phase I Environmental Site Assessment Bay Ho Improv 2 Project, dated April 13, 2022, by Allied Geotechnical Engineers, INC.
6. The reports listed above are available for review at the following link:  
[https://drive.google.com/drive/folders/1i9PjgkGqKRCJKJg-0IjXh2\\_QtbPjLC7H](https://drive.google.com/drive/folders/1i9PjgkGqKRCJKJg-0IjXh2_QtbPjLC7H)

**3-12.1 General.** To the "WHITEBOOK", ADD the following:

3. You shall sweep all paved areas within the Work site and all paved haul routes as specified below:
  - a) Every Friday on a weekly basis.
  - b) 1 Working Day prior to each rain event.
  - c) As directed by the Engineer.

If these requirements would require you to sweep on a Holiday or Weekend, then you shall sweep the next available Working Day prior to that Holiday or Weekend.

**3-12.7 Drinking Water Discharges Requirements.** To the "WHITEBOOK", ADD the following:

1. You shall record the results for each discharge event on the City's Drinking Water Discharge Monitoring form included as **Appendix H - Monthly Drinking Water Discharge Monitoring Form.**

**3-12.8.3 Equipment.** To the "WHITEBOOK", item 4, DELETE in its entirety and SUBSTITUTE with the following:

4. The approved dewatering system shall include a suitably sized pipeline to transport extracted groundwater from the Work Site to the indicated point of discharge as applicable under the dewatering permit in force during the dewatering operations. The alignment of this pipeline shall be subject to the

approval by the Engineer. Where the pipeline is allowed to cross roadways or parking areas, you shall be required to install a conduit below the traveled surface. The installation shall provide protection for the temporary pipeline and a smooth transition across the in accordance with Standard Drawing SDG-107, "Pavement Restoration for Asphalt Concrete Surfaced Streets - Major Excavation" or a concrete trench cap in accordance with Standard Drawing SDG-108, "Pavement Restoration for Concrete Surfaced Streets and Alleys - Major Excavation" as included in **Appendix M – Standard Drawings**.

**3-15.3 COORDINATION.** To the "WHITEBOOK", ADD the following:

2. Other adjacent City projects are scheduled for construction for the same time period in the vicinity of Southview Dr, Paducah Dr, Wicopee Pl, Caflur Ave, and Morena Blvd. See **Appendix F – Adjacent Projects Map** for the approximate location. Coordinate the Work with the adjacent projects as listed below:
  - a) Block 6DD1 (Clairemont Mesa) Rd Imp UU410, Project Manager: Farlito Valenzuela (619) 235-1947
  - b) Sewer & AC Water Group 1058, Project Manager: Jamal Sherzai (619) 533-4639
  - c) 16-in & Larger CI WS Main Repl Grp A (W), Project Manager: Mehrnaz Zare Afifi (619) 533-4656

**SECTION 4 - CONTROL OF MATERIALS**

**4-6 TRADE NAMES.** To the "WHITEBOOK", ADD the following:

11. You shall submit your list of proposed substitutions for an "equal" item **no later than 5 Working Days after the issuance of the Notice of Intent to Award** and on the City's Product Submittal Form available at:  
<https://www.sandiego.gov/ecp/edocref/>

**SECTION 5 – LEGAL RELATIONS AND RESPONSIBILITIES**

**5-4 INSURANCE.** To the "GREENBOOK", DELETE in its entirety and SUBSTITUTE with the following:

**5-4 INSURANCE.**

1. The insurance provisions herein shall not be construed to limit your indemnity and defense duties set forth in the Contract.

**5-4.1 Policies and Procedures.**

1. You shall procure the insurance described below, at your sole cost and expense, to provide coverage against claims for loss including injuries to persons or damage to property, which may arise out of or in connection with

the performance of the Work by you, your agents, representatives, officers, employees or Subcontractors.

2. Insurance coverage for property damage resulting from your operations is on a replacement cost valuation. The market value will not be accepted.
3. You shall maintain this insurance as required by this Contract and at all times thereafter when you are correcting, removing, or replacing Work in accordance with this Contract. Your duties under the Contract, including your indemnity obligations, are not limited to the insurance coverage required by this Contract.
4. If you maintain broader coverage or higher limits than the minimums shown below, City requires and shall be entitled to the broader coverage or the higher limits maintained by you. Any available insurance proceeds in excess of the specified minimum limits of insurance and coverage shall be available to City.
5. Your payment for insurance shall be included in the Contract Price you bid. You are not entitled to any additional payment from the City to cover your insurance, unless the City specifically agrees to payment in writing. Do not begin any Work under this Contract or allow any Subcontractors to begin work, until you have provided, and the City has approved, all required insurance.
6. Policies of insurance shall provide that the City is entitled to 30 days advance written notice of cancellation or non-renewal of the policy or 10 days advance written notice for cancellation due to non-payment of premium. Maintenance of specified insurance coverage is a material element of the Contract. Your failure to maintain or renew coverage and to provide evidence of renewal during the term of the Contract may be treated by the City as a material breach of the Contract.

## **5-4.2 Types of Insurance.**

### **5-4.2.1 General Liability Insurance.**

1. Commercial General Liability Insurance shall be written on the current version of the ISO Occurrence form CG 00 01 07 98 or an equivalent form providing coverage at least as broad.
2. The policy shall cover liability arising from premises and operations, XCU (explosions, underground, and collapse), independent contractors, products/completed operations, personal injury and advertising injury, bodily injury, property damage, and liability assumed under an insured's contract (including the tort liability of another assumed in a business contract).
3. There shall be no endorsement or modification limiting the scope of coverage for either "insured vs. insured" claims or contractual liability. You shall

maintain the same or equivalent insurance for at least 10 years following completion of the Work.

4. All costs of defense shall be outside the policy limits. Policy coverage shall be in liability limits of not less than the following:

<u>General Annual Aggregate Limit</u>	<u>Limits of Liability</u>
Other than Products/Completed Operations	\$10,000,000
Products/Completed Operations Aggregate Limit	\$10,000,000
Personal Injury Limit	\$5,000,000
Each Occurrence	\$5,000,000

**5-4.2.2 Commercial Automobile Liability Insurance.**

1. You shall provide a policy or policies of Commercial Automobile Liability Insurance written on the current version of the ISO form CA 00 01 12 90 or later version or equivalent form providing coverage at least as broad in the amount of \$1,000,000 combined single limit per accident, covering bodily injury and property damage for owned, non-owned, and hired automobiles (“Any Auto”).
2. All costs of defense shall be outside the limits of the policy.

**5-4.2.3 Workers’ Compensation Insurance and Employers Liability Insurance.**

1. In accordance with the provisions of California Labor Code section 3700, you shall provide, at your expense, Workers’ Compensation Insurance and Employers Liability Insurance to protect you against all claims under applicable state workers’ compensation laws. The City, its elected officials, and employees will not be responsible for any claims in law or equity occasioned by your failure to comply with this requirement.
2. Statutory Limits shall be provided for Workers’ Compensation Insurance as required by the state of California, and Employer’s Liability Insurance with limits of no less than \$1,000,000 per accident for bodily injury or disease.
3. By signing and returning the Contract, you certify that you are aware of the provisions of California’s Workers’ Compensation laws, including Labor Code section 3700, which requires every employer to be insured against liability for workers’ compensation or to undertake self-insurance, and that you will comply with these provisions before commencing the Work.

**5-4.2.4 Contractors Pollution Liability Insurance.**

1. You shall procure and maintain at your expense or require your Subcontractor, as described below, to procure and maintain Contractors Pollution Liability Insurance applicable to the Work being performed, with a

limit no less than \$2,000,000 per claim or occurrence and \$4,000,000 aggregate per policy period of one year.

2. All costs of defense shall be outside the limits of the policy.
3. You shall obtain written approval from the City for any insurance provided by your Subcontractor instead of you.
4. For approval of a substitution of your Subcontractor's insurance, you shall certify that all activities for which the Contractors Pollution Liability Insurance will provide coverage will be performed exclusively by the Subcontractor providing the insurance. The deductible shall not exceed \$25,000 per claim unless the City has provided prior, written approval.
5. Occurrence based policies shall be procured before the Work commences. Claims Made policies shall be procured before the Work commences, shall be maintained for the Contract Time, and shall include a 12-month extended Claims Discovery Period applicable to this contract or the existing policy or policies that shall continue to be maintained for 12 months after the completion of the Work without advancing the retroactive date.

#### **5-4.2.5 Contractors Hazardous Transporters Pollution Liability Insurance.**

1. You shall procure and maintain at your expense or require your Subcontractor, as described below, to procure and maintain Contractors Hazardous Transporters Pollution Liability Insurance, including contractual liability coverage to cover liability arising out of transportation of hazardous or toxic, materials, substances, or any other pollutants by you or any Subcontractor in an amount no less than \$2,000,000 limit per occurrence and \$4,000,000 aggregate per policy period of one year.
2. All costs of defense shall be outside the limits of the policy.
3. You shall obtain written approval from the City from any insurance provided by a Subcontractor instead of you.
4. To obtain City approval of a Subcontractor's insurance coverage in lieu of the Contractor's insurance, the Contractor shall certify that all activities under the Contractor's Hazardous Transporters Pollution Liability Insurance will be performed exclusively by the Subcontractor providing the insurance. The deductible shall not exceed \$25,000 per claim without prior approval of the City.
5. Occurrence based policies shall be procured before the Work commences. Claims Made policies shall be procured before the Work commences, shall be maintained for the duration of this contract, and shall include a 12-month extended Claims Discovery Period applicable to this Contract or the existing policy or policies that shall continue to be maintained for 12 months after the

completion of the Work under this Contract without advancing the retroactive date.

**5-4.2.8 Architects and Engineers Professional Insurance (Errors and Omissions Insurance).**

1. For Contracts with required engineering services, including Design-Build and preparation of engineered Traffic Control Plans (TCP) by you, you shall keep or require all of your employees and Subcontractors, who provide professional engineering services under Contract, to provide to the City proof of Professional Liability coverage with a limit of no less than **\$1,000,000** per claim and **\$2,000,000** aggregate per policy period of one year.
2. You shall ensure the following:
  - a) The policy retroactive date is on or before the date of commencement of the Project.
  - b) The policy will be maintained in force for a period of three years after completion of the Project or termination of the Contract, whichever occurs last. You agree that, for the time period specified above, there will be no changes or endorsements to the policy that affect the specified coverage.
3. If professional engineering services are to be provided solely by the Subcontractor, you shall:
  - a) Certify this to the City in writing, and
  - b) Agree in writing to require the Subcontractor to procure Professional Liability coverage in accordance with the requirements set forth here.

**5-4.3 Rating Requirements.** Except for the State Compensation Insurance Fund, all insurance required by this Contract shall be carried only by responsible insurance companies with a rating of, or equivalent to, at least "A-, VI" by A.M. Best Company, that are authorized by the California Insurance Commissioner to do business in the state of California, and that have been approved by the City.

**5-4.3.1 Non-Admitted Carriers.** The City will accept insurance provided by non-admitted, "surplus lines" carriers only if the carrier is authorized to do business in the state of California and is included on the List of Approved Surplus Lines Insurers (LASLI list).

All policies of insurance carried by non-admitted carriers shall be subject to all of the requirements for policies of insurance provided by admitted carriers described in this Contract.

**5-4.4 Evidence of Insurance.** You shall furnish the City with original Certificates of Insurance, including all required amendatory endorsements (or copies of the



applicable policy language effecting coverage required by this clause), prior to your commencement of Work under this Contract. In addition, The City reserves the right to require complete, certified copies of all required insurance policies, including endorsements, required by these specifications, at any time.

#### **5-4.5 Policy Endorsements.**

##### **5-4.5.1 Commercial General Liability Insurance.**

**5-4.5.1.1 Additional Insured.** To the fullest extent permitted by law and consistent with the limiting provisions set forth at California Civil Code section 2782, California Insurance Code section 11580.04, and any applicable successor statutes limiting indemnification of public agencies that bind the City, the policy or policies shall be endorsed to include as an Additional Insured the City and its respective elected officials, officers, employees, agents, and representatives, with respect to liability arising out of:

- i. Ongoing operations performed by you or on your behalf,
- ii. your products,
- iii. your work, e.g., your completed operations performed by you or on your behalf, or
- iv. premises owned, leased, controlled, or used by you.

**5-4.5.1.2 Primary and Non-Contributory Coverage.** The policy shall be endorsed to provide that the coverage with respect to operations, including the completed operations, if appropriate, of the Named Insured is primary to any insurance or self-insurance of the City and its elected officials, officers, employees, agents and representatives. Further, it shall provide that any insurance maintained by the City and its elected officials, officers, employees, agents and representatives shall be in excess of your insurance and shall not contribute to it.

**5-4.5.1.3 Project General Aggregate Limit.** The policy or policies shall be endorsed to provide a Designated Construction Project General Aggregate Limit that will apply only to the Work. Only claims payments which arise from the Work shall reduce the Designated Construction Project General Aggregate Limit. The Designated Construction Project General Aggregate Limit shall be in addition to the aggregate limit provided for the products-completed operations hazard.

##### **5-4.5.2 Workers' Compensation Insurance and Employers Liability Insurance.**

**5-4.5.2.1 Waiver of Subrogation.** The policy or policies shall be endorsed to provide that the insurer will waive all rights of subrogation against the City and its respective elected officials, officers, employees, agents, and representatives for losses paid under the terms of the policy or policies and which arise from Work performed by the Named Insured for the City.

### **5-4.5.3 Contractors Pollution Liability Insurance Endorsements.**

**5-4.5.3.1 Additional Insured.** To the fullest extent permitted by law and consistent with the limiting provisions set forth at California Civil Code section 2782, California Insurance Code section 11580.04, and any applicable successor statutes limiting indemnification of public agencies that bind the City, the policy or policies shall be endorsed to include as an Additional Insured the City and its respective elected officials, officers, employees, agents, and representatives, with respect to liability arising out of:

- a. Ongoing operations performed by you or on your behalf,
- b. your products,
- c. your work, e.g., your completed operations performed by you or on your behalf, or
- d. premises owned, leased, controlled, or used by you.

**5-4.5.3.2 Primary and Non-Contributory Coverage.** The policy or policies shall be endorsed to provide that the insurance afforded by the Contractors Pollution Liability Insurance policy or policies is primary to any insurance or self-insurance of the City and its elected officials, officers, employees, agents and representatives with respect to operations including the completed operations of the Named Insured. Any insurance maintained by the City and its elected officials, officers, employees, agents and representatives shall be in excess of your insurance and shall not contribute to it.

**5-4.5.3.3 Severability of Interest.** For Contractors Pollution Liability Insurance, the policy or policies shall provide that your insurance shall apply separately to each insured against whom claim is made or suit is brought, except with respect to the limits of the insurer's liability and shall provide cross-liability coverage.

### **5-4.5.4 Contractors Hazardous Transporters Pollution Liability Insurance Endorsements.**

**5-4.5.4.1 Additional Insured.** To the fullest extent permitted by law and consistent with the limiting provisions set forth at California Civil Code section 2782, California Insurance Code section 11580.04, and any applicable successor statutes limiting indemnification of public agencies that bind the City, the policy or policies shall be endorsed to include as an Additional Insured the City and its respective elected officials, officers, employees, agents, and representatives, with respect to liability arising out of:

- a. Ongoing operations performed by you or on your behalf,
- b. your products,
- c. your work, e.g., your completed operations performed by you or on your behalf, or
- d. premises owned, leased, controlled, or used by you.

**5-4.5.4.2 Primary and Non-Contributory Coverage.** The policy or policies shall be endorsed to provide that the insurance afforded by the Contractors Pollution Liability Insurance policy or policies is primary to any insurance or self-insurance of the City and its elected officials, officers, employees, agents and representatives with respect to operations including the completed operations of the Named Insured. Any insurance maintained by the City and its elected officials, officers, employees, agents and representatives shall be in excess of your insurance and shall not contribute to it.

**5-4.5.4.3 Severability of Interest.** For Contractors Hazardous Transporters Pollution Liability Insurance, the policy or policies shall provide that your insurance shall apply separately to each insured against whom claim is made or suit is brought, except with respect to the limits of the insurer's liability, and shall provide cross-liability coverage.

**5-4.6 Deductibles and Self-Insured Retentions.** You shall disclose deductibles and self-insured retentions to the City at the time the evidence of insurance is provided. The City may require you to purchase coverage with a lower retention or provide proof of ability to pay losses and related investigations, claim administration, and defense expenses within the retention. The policy language shall provide, or be endorsed to provide, that the self-insured retention may be satisfied by either the named insured or City.

**5-4.7 Reservation of Rights.** The City reserves the right, from time to time, to review your insurance coverage, limits, deductibles, and self-insured retentions to determine if they are acceptable to the City. The City will reimburse you, without overhead, profit, or any other markup, for the cost of additional premium for any coverage requested by the Engineer, but not required by this Contract.

**5-4.8 Notice of Changes to Insurance.** You shall notify the City, in writing, 30 days prior to any material change to the policies of insurance provided under this Contract. This written notice is in addition to the requirements of paragraph 6 of Section 5-4.1.

**5-4.9 Excess Insurance.** Policies providing excess coverage shall follow the form of the primary policy or policies, including, all endorsements.

**5-10.3 Exclusive Community Liaison Services.** To the "WHITEBOOK", ADD the following:

2. You shall retain an Exclusive Community Liaison for the Project that shall implement Work in accordance with the specifications described in 5-10.2 "Community Outreach Services" and 5-10.3 "Exclusive Community Liaison Services".

**ADD:**

**5-10.3.2 Weekly Updates Recipients.**

1. Submit a weekly correspondence with updates, traffic control issues and locations, lane closures, and any other pertinent information (with additional contact names given during award process) to the following recipients:

Roberto Valadez, Project Manager [RValadez@sandiego.gov](mailto:RValadez@sandiego.gov)

Isabel Bishop, Project Engineer, [ibishop@sandiego.gov](mailto:ibishop@sandiego.gov)

**5-10.4 Exclusive Community Liaison Services.** To the "WHITEBOOK", ADD the following:

3. The Exclusive Community Liaison shall answer project-related questions from the general public; notice private property owners prior to the sewer abandonment scope located within easements; notice property owners regarding street access and parking closures associated with the water replacement, sewer replacement, and street resurfacing; and notice property owners and answer questions regarding water shutdowns. The Exclusive Community Liaison shall post signage on each street with their contact information.

**SECTION 6 – PROSECUTION AND PROGRESS OF THE WORK**

**6-1.1 Construction Schedule.** To the "WHITEBOOK", ADD the following:

3. Refer to the Sample City Invoice materials in **Appendix D – Sample City Invoice with Cash Flow Forecast** and use the format shown.
4. The **90 & 120 Calendar Day** Plant Establishment Period is included in the stipulated Contract Time and shall begin with the acceptance of installation of the vegetation plan in accordance with Section 801-6, "MAINTENANCE AND PLANT ESTABLISHMENT".
5. All construction work related to 42048-D Sheets 3 & 26 shall be completed first, including associated street resurfacing. Contractor shall make arrangements through the Resident Engineer to coordinate activities in the areas with all conflicts.

**6-2.1 Moratoriums.** To the "WHITEBOOK", ADD the following:

4. Do not Work in the areas where there is currently a moratorium issued by the City. The areas subject to moratorium are listed below:
  - a) W Fox Ave from 6/1/2021 to 6/1/2026, inclusive.
  - b) Ecochee Ave from 6/1/2021 to 6/1/2026 inclusive.

**6-3 TIME OF COMPLETION.** To the "WHITEBOOK", ADD the following:

1. You shall complete the liner installation of all segments of sewer mains and the lateral reinstatements as verified by the Engineer within **35 Working Days** from the date of NTP. Complete the remaining Work as part of this project, including lateral lining and post-lining CCTV video, within the remaining number of Working Days.

**6-3.1 General.** To the "WHITEBOOK", Item 3, subitem d, DELETE in its entirety and SUBSTITUTE with the following:

- d) 30 Calendar Days for full depth asphalt final mill and resurfacing work required per SDG-107, "Pavement Restoration for Asphalt Concrete Surfaced Streets - Major Excavation" as included in **Appendix M – Standard Drawings**.

**ADD:**

**6-6.1.1 Environmental Document.**

1. The City of San Diego has prepared an **Addendum to Mitigated Negative Declaration** for **Bay Ho Improvements 2**, Project No. **697902**, as referenced in the Contract Appendix. You shall comply with all requirements of the **Addendum to Mitigated Negative Declaration** as set forth in **Appendix A**.
2. Compliance with the City's environmental document shall be included in the Contract Price, unless separate bid items have been provided.

**6-6.2.1 Archaeological and Native American Monitoring Program.** To the "WHITEBOOK", ADD the following:

4. You shall retain a qualified archaeologist and Native American Monitor for this Contract. You shall coordinate your activities and Schedule with the activities and schedules of the archaeologist and Native American monitor. Notify the Engineer before noon of the Working Day before monitoring is required. See 3-5, "INSPECTION" for details.

**6-6.2.2 Paleontological Monitoring Program.** To the "WHITEBOOK", ADD the following:

3. You shall retain a qualified paleontologist for this Contract. You shall coordinate your activities and Schedule with the activities and schedules of the paleontologist monitor. Notify the Engineer before noon of the Working Day before monitoring is required. See 3-5, "INSPECTION" for details.

**6-9 LIQUIDATED DAMAGES.** To the "WHITEBOOK", item 2, DELETE in its entirety and SUBSTITUTE with the following:

2. The execution of the Contract shall constitute agreement between you and the City that the liquidated damage amount described in the table below is the value of the damage caused by your failure to complete the Work within the allotted time. Such sum shall not be construed as a penalty and may be deducted from your payments if such delay occurs.

<b>Contract Value</b>	<b>Liquidated Damages Daily Amount</b>
Less than \$200,001	\$1,000
\$200,001 to \$500,000	\$1,500
\$500,001 to \$1,000,000	\$2,000

<b>Contract Value</b>	<b>Liquidated Damages Daily Amount</b>
\$1,000,001 to \$2,000,000	\$2,500
\$2,000,001 to \$5,000,000	\$3,000
\$5,000,001 to \$10,000,000	\$5,500
\$10,000,001 to \$20,000,000	\$6,500
Greater Than \$20,000,000	\$7,000

**SECTION 7 - MEASUREMENT AND PAYMENT**

**7-3.2.2.1 Progress Payment for Pipelines.** To the "WHITEBOOK", item 4, DELETE in its entirety and SUBSTITUTE with the following:

4. In asphalt-surfaced streets, the City shall pay 15% for hydrostatic and bacterial testing, Wayneball and Mandrelling (where necessary), for water and sewer utility constructions respectively, and operational testing for storm drains, including the trench cap and cleanup. The City shall pay the remaining 5% after completing the asphalt wearing surface, Trench Capping per SDG-107 "Pavement Restoration for Asphalt Concrete Surfaced Streets - Major Excavation" as included in **Appendix M - Standard Drawings**, and final cleanup.

**7-3.9 Field Orders.** To the "WHITEBOOK", DELETE in its entirety and SUBSTITUTE with the following:

1. If the cumulative total of Field Order items of Work does not exceed the "Field Orders" Bid Item, the City shall pay those Field Orders as shown below:

**TABLE 7-3.9  
FIELD ORDER LIMITS**

<b>Contract Price</b>	<b>Maximum Each Field Order Work Amount</b>
Less than \$1,000,001	\$10,000
\$1,000,001 to \$5,000,000	\$20,000
\$5,000,001 to \$10,000,000	\$25,000

<b>Contract Price</b>	<b>Maximum Each Field Order Work Amount</b>
\$10,000,001 to \$30,000,000	\$40,000
Greater than \$30,000,000	\$70,000

**7-3.11 Compensation Adjustments for Price Index Fluctuations.** To the "WHITEBOOK" ADD the following:

5. This Contract **is not** subject to the provisions of The "WHITEBOOK" for Compensation Adjustments for Price Index Fluctuations for paving asphalt.

### **SECTION 209 – PRESSURE PIPE**

**209-1.1.1 General.** To the "GREENBOOK", ADD the following:

1. PVC products, specifically type C900 and C905, as manufactured or distributed by J-M Manufacturing Company or JM Eagle shall not be used on the Contract for pressurized pipe.
2. Refer to AWWA C900-16 for all references to AWWA C905.

**209-7.2 Requirements.** To the "GREENBOOK", DELETE the following:

Table 209-7.2, DELETE "or Polywrap" from the "Type" Column.

### **SECTION 301 – SUBGRADE PREPARATION, TREATED MATERIALS, AND PLACEMENT OF BASE MATERIALS**

**301-1 SUBGRADE PREPARATION.** To the "GREENBOOK", ADD the following:

Prior to placement of fill, excavation bottoms should be scarified and compacted to at least 90 percent relative compaction based on ASTM D 1557. Fill should be placed at near optimum moisture and in uniform horizontal lifts not exceeding six to eight inches in loose lift thickness. Fill should be compacted to at least 90 percent of the maximum dry density as determined by ASTM D 1557, except in roadway, driveway and parking areas. The upper 12 inches of fill in areas to receive pavement or in parking areas should be compacted to at least 95 percent of maximum dry density (ASTM D 1557). Base course should be compacted to at least 95 percent of maximum dry density (ASTM D 1557). Due to the granular nature of the majority of the soils in this area, compaction should most easily be achieved with vibratory equipment.

**301-1.2 Preparation of Subgrade.** To the "WHITEBOOK", to Item 1. ADD the following:

Tests on import subgrade soil and existing soils to determine the "R" Value for pavement design shall be performed by the City or its duly authorized representative.

**301-1.6**

**Preparatory Repair Work.** To the "WHITEBOOK", DELETE in its entirety and SUBSTITUTE with the following:

1. Prior to the placement of any asphalt concrete or application of slurry, you shall complete all necessary preparation and repair Work and shall obtain approval by the Resident Engineer.
2. No preparatory asphalt Work shall be done when the atmospheric temperature is below 50° F (10° C) or during unsuitable weather.
3. Preparatory Work shall include tree trimming, weed spray, weed abatement, crack sealing, asphalt repair, cold milling, hump removal, lump removal, subgrade preparation and subgrade or base repair, removal of raised pavement markers, removal of pavement markings, location of public and private utilities and appurtenances, all Concrete works, and all other necessary works as specified in the Special Provisions and Contract Documents or as directed by the Engineer.
4. After the completion of the preparatory work, you shall install compacted asphalt concrete pavement according to the thickness specified in the Special Provisions and Contract Documents or a minimum of 2 inches (50.8 mm) for residential streets and a minimum of 3 inches (76.2 mm) for all other streets or as directed by the Engineer.
5. You shall identify the location of all utilities vaults, valves, and other appurtenances not included in the project scope requiring relocation or adjustment to grade by other agencies/companies by marking the face of the curb closest to the utility appurtenance as follows:
  1. Offset distance of the appurtenance from the curb face
  2. The limits of the appurtenance or corners of the vault/box
6. The quantities shown in the appendices are based on a street assessment survey and may vary. The Engineer will designate the limits to be removed and prepared and these designated areas shall be considered to take precedence over the areas shown in an Appendix to the Contract Documents.
7. You shall repair areas of distressed asphalt concrete pavement by milling or removing damaged areas of pavement to a minimum depth of 2 inches (50.8 mm) for residential streets and a minimum depth of 3 inches (76.2 mm) for all others except where specified otherwise in the Special Provisions and Contract Documents or as directed by the Engineer to expose firm and unyielding pavement as specified.
8. If, in order to achieve the minimum specified depth, the base material or native subgrade is exposed, you shall notify the Engineer the material shall be compacted to 95% relative compaction.



9. Compaction tests shall be made to ensure compliance with the specifications.
10. The QCP shall establish location and timing of compaction testing and shall be subject to approval by the Engineer. You shall reimburse the City for the cost of retesting failing compaction tests conducted as part of the City of San Diego Quality Assurance testing.
11. If additional base material is required, you shall use Class 2 Aggregate base in accordance with 200-2.9.1 "Class 2 Aggregate base (Scheduled, 5 Inch)" and "Class 2 Aggregate base (unscheduled, 5 Inch)" or as directed by the Engineer.
12. Prior to placement of compacted asphalt concrete pavement, you shall prepare the subgrade as needed and install a minimum of 2 or 3 inches as specified in the contract documents and special provisions, of compacted asphalt concrete pavement over native material as directed by the Engineer.
13. Areas of damaged asphalt requiring base repair work including excavation, placement of asphalt concrete, asphalt concrete base, and class 2 aggregate base, have been identified in the plan as "DO", Dig Out, also called Base Repairs.
14. The areas and quantities shown in the appendices are given only for the Contractor's aid in planning the Work and preparing Bids. You shall identify any new areas that require repair prior to paving in order to construct a smooth and stable pavement surface. Upon approval by the engineer, the repair locations shall be incorporated into scope of work and shall not be considered extra work. You shall mark the pavement area as "DO" or as directed by the Engineer.
15. Prior to replacing asphalt, the area shall be cleaned by removing all loose and damaged material, moisture, dirt, and other foreign matter and shall be tack coated in accordance with 302-5.4, "Tack Coat".
16. When milling and/or grinding asphalt pavement for base repair and the contractor encounters level and unyielding PCC trench caps or appurtenance collars before reaching the minimum depth of 2 inches, then the You shall place enough asphalt concrete pavement to bring the surface to be level with the adjacent roadway. Asphalt Concrete Base shall be Type III-B3-PG 64-10 and Asphalt Concrete Pavement shall be Type III-C2-PG 64-10 as directed by the Engineer.
17. You shall install new asphalt within the repair area or for patches in accordance with 302-5, "ASPHALT CONCRETE PAVEMENT". Asphalt concrete shall be Type III-C2-PG 64-10 in compliance with 203-6.3.1 "General".
18. Recycled base material shall conform to Class 2 Aggregate Base material in accordance with 200-2.4, "Class 2 Aggregate Base (Scheduled, 5 Inch)" and "Class 2 Aggregate Base (Unscheduled, 5 Inch)".

19. Following the asphalt placement, you shall roll the entire area of new asphalt in both directions at least twice. The finished patch shall be level and smooth in compliance with 302-5.6.2, "Density and Smoothness". After placement and compaction of the asphalt patch, you shall seal all finished edges with a 4 inch (101.6 mm) wide continuous band of SS-1H.
20. Materials removed, regardless of removal method, shall be disposed of at a legal site.
21. The minimum dimensions for each individual repair shall be 4 feet by 4 feet (1.2 m by 1.2 m) and shall be subject to the following conditions:
  - a. If the base material is exposed, to achieve the required minimum removal thickness, the base material shall be prepared conforming to 301-1, "SUBGRADE PREPARATION".
  - b. Base repairs shall have a minimum depth of 10".
  - c. You shall repair the areas shown in the appendices of distressed asphalt concrete to remove damaged areas of pavement in accordance with 404-1, to expose firm and unyielding pavement, base, or native soils, regardless of materials encountered. Unyielding pavement will have no visible cracks and unyielding base, or native soils will be properly compacted, as determined by the Engineer. If cracks are visible, then pavement is not unyielding and shall require additional depth be removed as directed by the Engineer. The Contractor shall prepare subgrade as needed and install a maximum of 5" compacted asphalt concrete pavement over the compacted base material to be level with the adjacent roadway surface.
  - d. When additional base material is required, then you shall use Class 2 Aggregate Base in accordance with 200-2.4, "Class 2 Aggregate Base (Scheduled, 5 Inch)" and "Class 2 Aggregate Base (Unscheduled, 5 Inch)" or as directed by the Engineer.
  - e. Recycled base material shall conform to Class 2 aggregate base material in accordance with 200-2.4, "Class 2 Aggregate Base (Scheduled, 5 Inch)" and "Class 2 Aggregate Base (Unscheduled, 5 Inch)".
  - f. You may use grinding as a method for removal of deteriorated pavement when the areas indicated for removal are large enough (a minimum of the machine drum width) and when approved by the Engineer.
  - g. For both scheduled and unscheduled base repairs, failed areas may be removed by milling or by excavation provided that the edges are cut cleanly with a saw. The areas shall be cleaned, and tack coated in

accordance with 302-5.4, "Tack Coat" before replacing the asphalt pavement.

- h. Base repair areas where failed pavement is removed either by cold milling or by excavation shall be restored to existing pavement grade with "Class 2 Aggregate Base (Scheduled, 5 Inch)" and "Class 2 Aggregate Base (Unscheduled, 5 Inch)" at 5 inches, and 5 inches of "Asphalt Concrete Base" shall be placed atop the layer of "Class 2 Aggregate Base (Scheduled, 5 Inch)" and "Class 2 Aggregate Base (Unscheduled, 5 Inch)" u
- i. Unless otherwise directed by the Engineer. These areas have been identified in the appendices as "DO". The Crushed Miscellaneous Base shall be in accordance with 200-2.9, "Class 2 Aggregate Base (Scheduled, 5 Inch)" and "Class 2 Aggregate Base (Unscheduled, 5 Inch)" The asphalt concrete base shall be Type III-B3-PG 64-10 as specified in 203-6, "ASPHALT CONCRETE". "General" Preliminary quantities are identified in the Contract appendix but may need to be increased and approved by the Engineer at the time of construction. Base Repairs shall not exceed 15% RAP in content.
- j. Base repair with asphalt concrete base areas where failed pavement is removed either by cold milling or by excavation shall be restored to existing pavement grade with Asphalt Concrete Base at 8 inch (203.2mm) and a minimum of 2 or 3 inches of asphalt concrete shall be placed atop the layer of Asphalt Concrete Base unless otherwise directed by the Engineer. The asphalt concrete base shall be Type III-B3-PG 64-10 as specified in 203-6, "ASPHALT CONCRETE." The asphalt concrete shall be Type III-C2-PG 64-10 as specified in 203-6, "General." Base Repairs shall not exceed 15% RAP in content. Base Repairs with Asphalt Concrete Base shall not be performed except where directed by the Engineer.
- k. A Base repair identified prior to initiation of the preparatory work shall be considered scheduled.
- l. A base repair is considered unscheduled when it is not identified in the appendices as "DO" prior to initiation of preparatory work or when you are directed by the Engineer to perform an unscheduled base repair for the proper placement of an asphalt overlay.
- m. At the end of each day the Contractor shall submit to the Engineer an itemized list of the asphalt pavement and base repair work completed. The list shall include but not be limited to the location of the work, the exact square footage of the repair, cubic yards of excavation, tons of asphalt concrete base placed, and tons of Class 2 Aggregate Base material placed or as directed by the Engineer.

**301-1.7**

**Payment.** To the "WHITEBOOK", DELETE in its entirety and SUBSTITUTE with the following:

1. The demolition, removal, and disposal of various types of existing hardscape in parkway areas, such as colored concrete, bricks, flagstone in the parkway or right-of-way, shall be included under the lump sum Bid items or for the Contract Unit Prices for which hardscape removal is required. When required, hardscape in parkways shall be replaced with Class A Top Soil or as directed by the Engineer.
2. The payment for the preparatory works shall be included in the lump sum Bid Items and Contract Unit Prices for which preparation works are performed, unless it is specified as a separate Bid Item.
3. The areas and quantities shown in the appendices are given only for the Contractor's aid in planning the Work and preparing Bids. The Engineer will designate the limits to be removed and prepared and these designated areas shall be considered to take precedence over the areas shown in an Appendix to the Contract Documents. The quantities shown in the appendices are based on a street assessment survey and may vary. No payment shall be made for areas of over excavation as determined by the Engineer.
4. Asphalt pavement subgrade repair, and base repair dig-outs, shall be paid at the Contract unit price for "**Excavate and Export (Scheduled, 10 Inch)**" and "**Excavation and Export (Unscheduled, 10 Inch)**", "**Asphalt Concrete Base (Scheduled, 5 Inch)**" and "**Asphalt Concrete Base (Unscheduled, 5 Inch)**", "**Class 2 Aggregate Base (Scheduled, 5 Inch)**" and "**Class 2 Aggregate Base (Unscheduled, 5 Inch)**". No Payment shall be made for areas of over excavation as determined by the Engineer.
5. When Cold Milling is used as a method for excavation for subgrade or base repair for pavement, Cold Milling shall be included in the Contract Unit Price for "**Excavate and Export (Scheduled, 10 Inch)**" or "**Excavation and Export (Unscheduled, 10 Inch)**".
6. The payment for Excavation shall be paid at the Contract Unit Price for "**Excavate and Export (Scheduled, 10 Inch)**" or "**Excavation and Export (Unscheduled, 10 Inch)**" for each bank cubic yard of material removed. Proof of proper disposal and/or recycling at a legal site for quantities excavated shall be required in advance of payment as directed by the Engineer and shall be subject to approval by the Engineer for payment. No additional payment shall be made for milling, grinding, saw cutting, hauling, disposal of concrete, pavement fabric, rubberized material, steel reinforcement, or any other material.
7. No additional payment shall be made for milling, grinding, saw cutting, stockpiling, hauling, disposal of concrete, pavement fabric, rubberized material, steel reinforcement, or any other material.

**301-2.4 Measurement and Payment.** To the "GREENBOOK", ADD the following:

1. Payment for Class 2 aggregate base material installed shall be made at the Contract Unit Price for "**Class 2 Aggregate Base (Scheduled, 5 Inch)**" and "**Class 2 Aggregate Base (Unscheduled, 5 Inch)**" per ton and includes all necessary works such as hauling, placement, and compaction as directed by the Engineer.

#### **SECTION 302 – ROADWAY SURFACING**

**302-5.2 Pavement Restoration Adjacent to Trench.** To the "WHITEBOOK", DELETE in its entirety and SUBSTITUTE with the following:

**302-5.2 Pavement Restoration Adjacent to Trench Influence Zone.**

The Work for pavement restoration shall include the replacement of existing pavement outside of the trench influence zone in accordance with SECTION 302 – ROADWAY SURFACING and as shown on the Plans.

1. Prior to the commencement of the Work, you shall meet with the Engineer and determine the limits of the pavement to be replaced.
2. Existing pavement shall be removed in accordance with SECTION 404 – COLD MILLING, and as shown on the Plans.
3. Areas of damaged pavement requiring base repair Work shall be restored in accordance with Section 301-1.6, "Preparatory Repair Work", and as shown on the Plans.

**302-5.2.1 Measurement and Payment.** To the "WHITEBOOK", item 1, DELETE in its entirety and SUBSTITUTE with the following:

1. The payment for asphalt concrete pavement restoration outside of the trench influence zone shall be made on a tonnage basis in accordance with Section 302-5.9 "Measurement and Payment" and paid for under Bid Item "**Asphalt Concrete Overlay (2 inch)**", unless separate Bid items have been provided. The following shall be included in the payment for "**Asphalt Concrete Overlay (2 inch)**"
  - a) Saw-cutting existing edges.
  - b) Applying tack coat.
  - c) Placement, curing, and protection of new pavement.
2. The payment for removal of existing asphalt concrete pavement shall be made on square foot basis in accordance with Section 404-12, "Payment" and paid for under Bid Item "**Cold Milling (2 inch)**".
3. The payment for base repair Work shall be made in accordance with Section 301-1.7, "Payment".

**302-6.1**      **General.** To the "WHITEBOOK", Item 3, DELETE in its entirety and SUBSTITUTE with the following:

3.      The thickness of the new concrete pavement shall be in accordance with Standard Drawing SDG-108, "Pavement Restoration for Concrete Surfaced Streets and Alleys - Major Excavation" as included in **Appendix M – Standard Drawings**.

**SECTION 306 – OPEN TRENCH CONDUIT CONSTRUCTION**

**306-1**      **GENERAL.** To the "GREENBOOK", ADD the following:

1.      All Work under this section shall be subject to the applicable permanent resurfacing restoration requirements in accordance with the following City of San Diego Standard Drawings as included in **Appendix M – Standard Drawings**.
  - a)      SDG-105, "Pavement Restoration General Notes"
  - b)      SDG-107, "Pavement Restoration for Asphalt Concrete Surfaced Streets - Major Excavation"
  - c)      SDG-108, "Pavement Restoration for Concrete Surfaced Streets and Alleys - Major Excavation"
  - d)      SDG-117, "Pavement Restoration for Asphalt Concrete Surface Streets - Minor Excavation"
  - e)      SDG-118, "Pavement Restoration for Concrete Surface Streets and Alleys - Minor Excavation"

**ADD:**

**306-1.1**      **High-line Phasing.**

1.      Build the Project in accordance with the water high-lining phasing shown on the Plans and in phases as follows:
  - a)      Phase I:    Sheets C-29 & C-30
  - b)      Phase II:    Sheets C-31, C-39 & C-40
  - c)      Phase III:    Sheets C-32, C-33 & C-34
  - d)      Phase IV:    Sheets C-35, C-36, C-37 & C-38

**306-3.3.4**      **Payment.** To the "WHITEBOOK", ADD the following:

12.      The payment for pavement restoration including influence area shall be included in the Bid Items for the associated abandonment Work.

13. The payment for removing existing fire hydrants outside the proposed trench limits as shown on the Plans shall be included in the Bid item for **"Removal or Abandonment of Existing Water Facilities (Fire Hydrants)"**.

**306-7.8.2.1 General.** To the "WHITEBOOK", Item 2, DELETE in its entirety and SUBSTITUTE with the following:

2. Pressure testing of pipe and fittings at the lowest elevation shall be performed at 150% of the specified test pressure and no less than 100% of the specified test pressure at the highest elevation.
  - a) Specified test pressure for Class 235 pipe shall be 150 psi and is tested at 225 psi.
  - b) Specified test pressure for Class 305 pipe shall be 200 psi and is tested at 300 psi.

**306-15 PAYMENT.** To the "GREENBOOK", ADD the following:

1. Payment for pavement restoration, including influence area, shall be included in the associated Bid Items pertinent to the Work.

**306-15.1 General.** To the "GREENBOOK", Item 1, subitem n, DELETE in its entirety and SUBSTITUTE with the following:

- n) Permanent resurfacing. See **306-1 General** for permanent pavement restoration requirements.

**306-15.6 Hydrants.** To the "WHITEBOOK", ADD the following:

5. Payment for pavement restoration, including influence area, shall be included in the associated Bid Items pertinent to the Work.
6. See **306-1 General** for permanent resurfacing requirements.

**306-15.7 Buried Structures.** To the "WHITEBOOK", DELETE in its entirety and SUBSTITUTE with the following:

**306-15.7 Buried Structures.** To the "GREENBOOK", sentence (3), DELETE in its entirety and SUBSTITUTE with the following:

The Contract Unit Price shall include excavation, backfill, disposal of all excess excavation, constructing inverts, furnishing and installing castings, restoration of the street surface (See **306-1 General** for permanent resurfacing requirements) and improvements including but not limited to sidewalk panel, and all other Work, excluding temporary resurfacing, necessary to construct the buried structure, complete in-place.

**306-15.8 Pipeline Appurtenances.** To the "WHITEBOOK", ADD the following:

10. Payment for pipeline appurtenances will be made at the contract unit price for each appurtenance of the size including permanent resurfacing requirements. See **306-1 General** for permanent resurfacing requirements.

**306-16.6 Payment.** To the "WHITEBOOK", ADD the following:

6. All Work under this section shall be subject to the applicable permanent resurfacing restoration requirements in accordance with the following City of San Diego Standard Drawings. Payment for pavement restoration, including influence area, shall be included in the associated Bid items pertinent to the Work.
  - a) See **306-1 General** for permanent resurfacing requirements.
7. **"Manhole (Lined 8 ft, per 42048-87-D & 42048-88-D)"** shall be measured as Each. The contract Each price paid for **"Manhole (Lined 8 ft, per 42048-87-D & 42048-88-D)"** shall include full compensation for the contractor to:
  - a) Procure signed and sealed design and calculations of the special design manholes.
  - b) Furnish all materials, labor, tools, and equipment for special design manhole construction.
  - c) Perform all work necessary to complete, maintain, and warrantee the special design manhole structures.

**306-17.2 Payment.** To the "WHITEBOOK", ADD the following:

12. All Work under this section shall be subject to the applicable permanent resurfacing restoration requirements in accordance with the following City of San Diego Standard Drawings. Payment for pavement restoration, including influence area, shall be included in the associated Bid Items pertinent to the Work.
13. **306-1 General** for permanent resurfacing requirements.

### **SECTION 307 - JACKING AND TUNNELING**

**307-1 JACKING OPERATIONS.** To the "GREENBOOK", ADD the following:

1. All Work under this section shall be subject to the applicable permanent resurfacing restoration requirements in accordance with the following City of San Diego Standard Drawings as included in **Appendix M - Standard Drawings**. Payment for pavement restoration, including influence area, shall be included in the associated Bid Items pertinent to the Work.
  - a) SDG-105, "Pavement Restoration General Notes"
  - b) SDG-107, "Pavement Restoration for Asphalt Concrete Surfaced Streets - Major Excavation"



- c) SDG-108, "Pavement Restoration for Concrete Surfaced Streets and Alleys - Major Excavation"
- d) SDG-117, "Pavement Restoration for Asphalt Concrete Surface Streets - Minor Excavation"
- e) SDG-118, "Pavement Restoration for Concrete Surface Streets and Alleys - Minor Excavation"

**307-1.7 Payment.** To the "WHITEBOOK", ADD the following:

- 2. All Work under this section shall be subject to the applicable permanent resurfacing restoration requirements in accordance with the following City of San Diego Standard Drawings. Payment for pavement restoration, including influence area, shall be included in the associated Bid Items pertinent to the Work.
- 3. See **307-1 JACKING OPERATIONS** for permanent resurfacing requirements.

### **SECTION 308 - MICROTUNNELING**

**308-1 GENERAL.** To the "GREENBOOK", ADD the following:

- 1. All Work under this section shall be subject to the applicable permanent resurfacing restoration requirements in accordance with the following City of San Diego Standard Drawings as included in **Appendix M - Standard Drawings**. Payment for pavement restoration, including influence area, shall be included in the associated Bid Items pertinent to the Work.
  - a) SDG-105, "Pavement Restoration General Notes"
  - b) SDG-107, "Pavement Restoration for Asphalt Concrete Surfaced Streets - Major Excavation"
  - c) SDG-108, "Pavement Restoration for Concrete Surfaced Streets and Alleys - Major Excavation"
  - d) SDG-117, "Pavement Restoration for Asphalt Concrete Surface Streets - Minor Excavation"
  - e) SDG-118, "Pavement Restoration for Concrete Surface Streets and Alleys - Minor Excavation"

**308-10 RESTORATION OF SURFACE IMPROVEMENTS.** To the "GREENBOOK", DELETE in its entirety and SUBSTITUTE with the following:

See Section **308 -1 General** for permanent resurfacing requirements.

**308-12**      **PAYMENT.** To the "WHITEBOOK", DELETE in its entirety and SUBSTITUTE with the following:

1.      The payment for microtunneling, including casing, carrier pipes, and surface improvement restoration, shall be included in the Bid Item for "**Sewer Main by Microtunneling with Steel Casing**".

**SECTION 315 - HORIZONTAL DIRECTIONAL DRILLING**

**315-1**      **GENERAL.** To the "WHITEBOOK", ADD the following:

2.      All Work under this section shall be subject to the applicable permanent resurfacing restoration requirements in accordance with the following City of San Diego Standard Drawings as included in **Appendix M - Standard Drawings**. Payment for pavement restoration, including influence area, shall be included in the associated Bid Items pertinent to the Work:
  - a)      SDG-105, "Pavement Restoration General Notes"
  - b)      SDG-107, "Pavement Restoration for Asphalt Concrete Surfaced Streets - Major Excavation"
  - c)      SDG-108, "Pavement Restoration for Concrete Surfaced Streets and Alleys - Major Excavation"
  - d)      SDG-117, "Pavement Restoration for Asphalt Concrete Surface Streets - Minor Excavation"
  - e)      SDG-118, "Pavement Restoration for Concrete Surface Streets and Alleys - Minor Excavation"

**315-14**      **MEASUREMENT AND PAYMENT.** To the "WHITEBOOK", ADD the following:

3.      See Section **315-1 GENERAL** for permanent resurfacing requirements.

**SECTION 316 - PIPE BURSTING**

**316-1**      **GENERAL.** To the "WHITEBOOK", ADD the following:

2.      All Work under this section shall be subject to the applicable permanent resurfacing restoration requirements in accordance with the following City of San Diego Standard Drawings as included in **Appendix M - Standard Drawings**. Payment for pavement restoration, including influence area, shall be included in the associated Bid Items pertinent to the Work.
  - a)      SDG-105, "Pavement Restoration General Notes"
  - b)      SDG-107, "Pavement Restoration for Asphalt Concrete Surfaced Streets - Major Excavation"

- c) SDG-108, "Pavement Restoration for Concrete Surfaced Streets and Alleys - Major Excavation"
- d) SDG-117, "Pavement Restoration for Asphalt Concrete Surface Streets - Minor Excavation"
- e) SDG-118, "Pavement Restoration for Concrete Surface Streets and Alleys - Minor Excavation"

**316-9 MEASUREMENT AND PAYMENT.** To the "WHITEBOOK", ADD the following:

- 3. See Section **316-1 GENERAL** for permanent resurfacing requirements.

### **SECTION 317 - PIPE FUSION**

**317-1 PIPE FUSION FOR SEWER MAINS.** To the "WHITEBOOK", ADD the following:

- 1. All Work under this section shall be subject to the applicable permanent resurfacing restoration requirements in accordance with the following City of San Diego Standard Drawings as included in **Appendix M - Standard Drawings**. Payment for pavement restoration, including influence area, shall be included in the associated Bid Items pertinent to the Work.
  - a. SDG-105, "Pavement Restoration General Notes"
  - b. SDG-107, "Pavement Restoration for Asphalt Concrete Surfaced Streets - Major Excavation"
  - c. SDG-108, "Pavement Restoration for Concrete Surfaced Streets and Alleys - Major Excavation"
  - d. SDG-117, "Pavement Restoration for Asphalt Concrete Surface Streets - Minor Excavation"
  - e. SDG-118, "Pavement Restoration for Concrete Surface Streets and Alleys - Minor Excavation"

**317-1.10 Payment.** To the "WHITEBOOK", ADD the following:

- 3. See Section **317-1 PIPE FUSION FOR SEWER MAINS** for permanent resurfacing requirements.

**317-2.12 Payment.** To the "WHITEBOOK", ADD the following:

- 3. See Section **317-1 PIPE FUSION FOR SEWER MAINS** for permanent resurfacing requirements.

## SECTION 400 – PROTECTION AND RESTORATION

**400-1 GENERAL.** To the "WHITEBOOK", ADD the following:

6. All Work under this section shall be subject to the applicable permanent resurfacing restoration requirements in accordance with the following City of San Diego Standard Drawings as included in **Appendix M – Standard Drawings**. Payment for pavement restoration, including influence area, shall be included in the associated Bid Items pertinent to the Work.
  - a) SDG-105, "Pavement Restoration General Notes"
  - b) SDG-107, "Pavement Restoration for Asphalt Concrete Surfaced Streets - Major Excavation"
  - c) SDG-108, "Pavement Restoration for Concrete Surfaced Streets and Alleys - Major Excavation"
  - d) SDG-117, "Pavement Restoration for Asphalt Concrete Surface Streets - Minor Excavation"
  - e) SDG-118, "Pavement Restoration for Concrete Surface Streets and Alleys - Minor Excavation"

## SECTION 401 – REMOVAL

**401-3.1 Concrete Pavement.** To the "WHITEBOOK", ADD the following:

4. See Section **400-1 GENERAL** for permanent resurfacing requirements.

**401-3.2 Concrete Curb, Walk, Gutters, Cross Gutters, Curb Ramps, Driveway, and Alley Intersections.** To the "WHITEBOOK", ADD the following:

7. See Section **400-1 GENERAL** for permanent resurfacing requirements.

## SECTION 402 – UTILITIES

**402-1.1 General.** To the "GREENBOOK", paragraph 5, DELETE in its entirety and SUBSTITUTE with the following:

The Contractor shall complete excavation, backfill, and placement of temporary resurfacing on the same Day. Backfill shall conform to 306-12 Temporary resurfacing shall conform to 306-13.1. Permanent resurfacing shall be placed within 10 Working Days unless otherwise specified in the Special Provisions or directed by the Engineer. See Section **400-1 GENERAL** for permanent resurfacing requirements.

To the "WHITEBOOK", Item 2, DELETE in its entirety and SUBSTITUTE with the following:

2. You shall fill all potholes on the same day of potholing if no trenching is to be performed within 10 Working Days of the excavation. Fully restore all potholes and any damaged surrounding areas to their original condition unless otherwise specified by the Engineer. Permanent resurfacing shall conform to SDG-123, "36-Inch and Smaller Pothole and Exploratory Excavation" as included in **Appendix M - Standard Drawings**.

#### **SECTION 402 - UTILITIES**

**402-2 PROTECTION.** To the "WHITEBOOK", Item 2, ADD the following:

- g) Refer to **Appendix L - Advanced Metering Infrastructure (AMI) Device Protection** for more information on the protection of AMI devices.

**402-6 COOPERATION.** To the "WHITEBOOK", ADD the following:

1. Notify SDG&E at least **15 Working Days** prior to excavating within 10 feet of SDG&E Underground High Voltage Transmission Power Lines (69 KV and higher).

**402-8 PAYMENT.** To the "WHITEBOOK", ADD the following:

6. Payment for pavement restoration, including influence area, shall be included in the associated Bid Items pertinent to the Work.

#### **SECTION 404 - COLD MILLING**

**404-1 GENERAL.** To the "WHITEBOOK", Item 1, DELETE in its entirety and SUBSTITUTE with the following:

1. Excessive asphalt concrete pavement adjacent to Type "G" and "H" curb and gutter lines and concrete cross gutters shall be milled in accordance with the City of San Diego Standard Drawing SDG-107, "Pavement Restoration for Asphalt Concrete Surfaced Streets - Major Excavation" as included in **Appendix M - Standard Drawings** or as shown on the Plans.

#### **SECTION 500 - PIPELINE REHABILITATION**

**500-1 GENERAL.** To the "WHITEBOOK", ADD the following:

5. All Work under this section shall be subject to the applicable permanent resurfacing restoration requirements in accordance with the following City of San Diego Standard Drawings as included in **Appendix M - Standard Drawings**. Payment for pavement restoration, including influence area, shall be included in the associated Bid Items pertinent to the Work.

- a) SDG-105, "Pavement Restoration General Notes"
- b) SDG-107, "Pavement Restoration for Asphalt Concrete Surfaced Streets - Major Excavation"
- c) SDG-108, "Pavement Restoration for Concrete Surfaced Streets and Alleys - Major Excavation"
- d) SDG-117, "Pavement Restoration for Asphalt Concrete Surface Streets - Minor Excavation"
- e) SDG-118, "Pavement Restoration for Concrete Surface Streets and Alleys - Minor Excavation"

**500-2.1 Initial Submittals.** To the "WHITEBOOK", Item 1, ADD the following:

Items shall be submitted in accordance with the required documents schedule.

**500-4.7 Payment.** To the "WHITEBOOK", DELETE in its entirety and SUBSTITUTE with the following:

1. The point repair Work shall be measured and paid for in the Bid Item for each **"Point Repair for Existing Sewer Main"**. Measurement shall be made at the pipe and shall be based on the length of pipe repaired. You shall be paid for 1 point repair for each repair 8 ft (2.43 m) or less in length. Any continuous point repair greater than 8 ft (2.43 m), shall be paid linearly proportioned to Bid Item **"Point Repair for Existing Sewer Main"**. This payment shall include all necessary labor, materials, and equipment to clean, repair, excavate, inspect the Point Repair, backfill and restore pavement. See **500-1 General** for permanent pavement restoration requirements.

### **SECTION 503 – SERVICE LATERAL REHABILITATION**

**503-1 GENERAL.** To the "WHITEBOOK", ADD the following:

7. All Work under this section shall be subject to the applicable permanent resurfacing restoration requirements in accordance with the following City of San Diego Standard Drawings as included in **Appendix M – Standard Drawings**. Payment for pavement restoration, including influence area, shall be included in the associated Bid Items pertinent to the Work.
  - a) SDG-105, "Pavement Restoration General Notes"
  - b) SDG-107, "Pavement Restoration for Asphalt Concrete Surfaced Streets - Major Excavation"
  - c) SDG-108, "Pavement Restoration for Concrete Surfaced Streets and Alleys - Major Excavation"
  - d) SDG-117, "Pavement Restoration for Asphalt Concrete Surface Streets - Minor Excavation"

- e) SDG-118, "Pavement Restoration for Concrete Surface Streets and Alleys - Minor Excavation"

**503-6** **PAYMENT.** To the "WHITEBOOK" Item 3, DELETE in its entirety and SUBSTITUTE with the following:

- 3. The point repair Work for sewer laterals shall be in accordance with 500-4, "PIPELINE POINT REPAIR AND/OR REPLACEMENT" and shall be included in the Bid Item for each "**Point Repair for Existing Sewer Lateral**". Measurement shall be made at the pipe and shall be based on the length of pipe repaired. You shall be paid for 1 point repair for each repair 8 ft (2.43 m) or less in length. Any continuous point repair greater than 8 ft (2.43 m), shall be paid linearly proportioned to Bid Item "**Point Repair for Existing Sewer Main**". This payment shall include all necessary labor, materials, and equipment to clean, repair, excavate, inspect the Point Repair, backfill, pavement restoration (and influence area) including sidewalks, driveways and any other above ground improvements.

**SECTION 601 - TEMPORARY TRAFFIC CONTROL FOR CONSTRUCTION AND MAINTENANCE WORK ZONES**

**601-7** **PAYMENT.** To the "WHITEBOOK" Item 1, DELETE in its entirety and SUBSTITUTE with the following:

- 1. The payment for traffic control Working Drawings, permits, traffic control Work, and the implementation of the Engineered Traffic Control Plans page **42048-TC1-D** through **42048-TC13-D**, including any traffic control devices that may be required by the City, shall be included in Bid item for "**Traffic Control and Working Drawings**".

**SECTION 700 - MATERIALS**

**700-1.3** **(86-1.02B) Conduit.** To the "WHITEBOOK", Item 1, DELETE in its entirety and SUBSTITUTE with the following:

- 1. When approved by the Engineer, conduit runs shown on the plans to be located behind curbs may be installed in the street, within 4 feet of and parallel to the curb, by narrow trenching. All pull boxes shall be located behind the curb or at locations shown on the plans. Narrow trenching shall be performed in accordance with the latest City Standards. Any changes in conduit location shall be approved in advance by the Engineer. All narrow trenching shall conform to the City of San Diego Standard Drawings SDG-117, "Pavement Restoration for Asphalt Concrete Surface Streets - Minor Excavation", SDG-118, "Pavement Restoration for Concrete Surface Streets and Alleys - Minor Excavation" as included in **Appendix M - Standard Drawings** and be inspected prior to backfill. Trenches behind sidewalks shall be compacted using compaction tools to ensure no sinking of trench will occur. Trenches wider than 6 inch (15.2 cm) shall conform to the City of San Diego Standard

Drawings SDG-107, "Pavement Restoration for Asphalt Concrete Surfaced Streets - Major Excavation", SDG-108, "Pavement Restoration for Concrete Surfaced Streets and Alleys - Major Excavation" as included in **Appendix M - Standard Drawings**, and SDG-119, "Trench Types G, H & I Backfill for Dry Utility". A 3-inch (7.6 mm) bed of fine soil or sand shall be placed in the trench.

## SECTION 701 - CONSTRUCTION

**701-2 PAYMENT.** To the "WHITEBOOK", Item 3, DELETE in its entirety and SUBSTITUTE with the following:

3. The payment for the trenching and pavement restoration, including influence areas, is included in the payment for the associated Work.

To the "WHITEBOOK", item 5, ADD the following:

- u) The payment for furnishing and installing (1) the pole foundation and base plate, (2) the conduit from the adjacent pull box into the pole foundation, (3) the signal pole, and (4) two pedestrian push button housing assemblies shall be included in the Bid item "**Pedestrian Push Button and Foundation**".

## SECTION 800 - MATERIALS

**800-1.2.5 Mulch.** To the "WHITEBOOK", Item 3, subsection "i", ADD the following:

**Type 9 Mulch** shall be 2 or 4 inches maximum in size.

**ADD**

**800-1.2.7 Herbicides and Pesticides.**

1. Herbicides and pesticides shall be used in their appropriate applications with strict adherence to manufacturers' specifications and instructions. Herbicides and pesticides shall be applied by licensed applicators. The Contractor shall obtain approval for all pesticide and herbicide use in writing from the Resident Engineer.
2. Post-emergent herbicide for all areas shall be Round Up, Diquat, Montar, or approved equivalent, except for areas where it may contact standing or running water.
3. Post-emergent herbicide for all areas where herbicide may encounter standing or moving water shall be Aquamaster, Rodeo, or approved equal specifically approved for use near water bodies. These herbicides are approved for use within the riparian areas by the City and County of San Diego because it has been determined to be non-toxic to aquatic organisms. Other herbicides shall be approved by the City and County of San Diego prior to use on only the most noxious weeds, and only under the direct supervision of the Resident Engineer.



## SECTION 801 - INSTALLATION

**801-1 GENERAL.** To the "WHITEBOOK", ADD the following:

5. All plants outside the limit of work shall be protected in place.
6. Do not operate equipment which generates fumes or excessive heat, within 20' of the trees to remain. Fumes and heat can damage trees.
7. The grade around existing trees to remain shall remain as existing to avoid disturbance of roots and avoid burying the roots under additional soil.
8. When excavation must be carried out under or near the dripline of a tree identified to be protected in place, the construction of improvements shall minimally damage the root zone by root pruning as outlined in Section 801-7.3, "Root Pruning for Sidewalk Replacement". Depth of root pruning shall occur to the depth necessary to construction improvements. Exposed roots of trees shall be covered and shaded by moist burlap or canvas until backfill is placed.
9. Upon completion of all work, remove tools, equipment, tree preservation materials and other measures from the site.
10. Repair all areas, structures, and surfaces damaged and requiring repair resulting from tree preservation measures. Repair adjacent construction or surfaces soiled or damaged by tree preservation measures.
11. Payment for pruning of existing trees and vegetation to remain shall be included in the lump sum Bid Item for "Construction of Park Improvements" and no additional payment will be made.

**ADD:**

### **801-2.2.1.1 Weed Eradication.**

1. Soil preparation and planting shall not be allowed until all weeds are removed from within the limits of planting areas as indicated on the plans.
2. The Contractor's labor shall possess demonstrated ability to identify the difference between desirable native species and invasive weeds.
3. Weed eradication for entire project site. After irrigation installation, but before planting installation, the Contractor shall irrigate the entire project site three (3) to four (4) times over seven (7) to ten (10) days to germinate existing weed seeds. Allow weed seeds to grow until they reach a maximum height of two to three inches (2" - 3"). A post-emergent herbicide shall then be applied per Section 800-1.2.7, "Herbicides and Pesticides". Avoid contact of herbicide with the existing plants to remain.
4. All herbicides used shall be compatible with use in the vicinity of water and shall be applied in accordance with the label specifications by personnel holding a valid pesticide and herbicide applicator's license. Herbicide use shall be approved by the Resident Engineer prior to application.

5. Pulled weeds and debris shall be transported and disposed of properly offsite immediately using approved methods to prevent any seed dispersal on the site.
6. The eradication of exotic plant species is required prior to any planting. All exotic vegetation within the planting areas shall be removed. Herbicide shall be applied to weedy vegetation (e.g., giant reed (*Arundo donax*), tamarisk (*Tamarix* sp.), pampas grass (*Cortaderia jubata*), tree tobacco (*Nicotina glauca*), yellow star-thistle (*Centaurea melitnesis*), cocklebur (*Xanthium* sp.), castor bean (*Ricinus communis*), annual beardgrass, and Bermuda grass (*Cynodon dactylon*), etc.) within the project area. All weedy species should be cleared approximately two weeks following herbicide application.
7. The Resident Engineer shall inspect the site prior to and during revegetation. The planting of hydroseed shall be conducted on a weed free site.
8. Manual weed eradication shall continue during planting and during the plant establishment period and maintenance period; no herbicides shall be used following the initial weed eradication unless authorized by the Resident Engineer. Weed seedlings and sprouts shall be removed before attaining 12-inches in height and/or before producing seed.
9. All areas where weed removal creates bare areas in excess of 25 square feet shall be reseeded.
10. "Weed Eradication" shall be measured as Square Feet. The contract Square Feet price paid for "Weed Eradication" shall include full compensation for furnishing all materials, labor, and tools to perform all work necessary to complete the "Weed Eradication" described or specified in these Special Provisions and Contract Documents and no additional compensation will be allowed therefore.

**801-4.1 General.** To the "WHITEBOOK", ADD the following:

7. The Contractor shall be responsible for managing the site and performing planting, maintenance, and corrective measures to the best advantage of the plant material to promote healthy growth, establishment, and success of the plantings. This shall include providing for drainage, irrigation, repair of damaged features, correction of deleterious conditions, maintaining a proper soil moisture level, weeding, fertilization, protection, temporary measures to promote establishment and other reasonable maintenance and construction efforts needed to provide for the successful establishment of the plant materials during the entire contract period.
8. The Contractor shall not install planting as shown in the plans when it is obvious in the field that conditions exist which are detrimental to plant survival and growth. Such conditions shall be brought to the attention of the Resident Engineer. The successful establishment of the plantings during the entire contract period is the Contractor's responsibility.

**801-4.9.3 Seeding and Mulching.** To the "GREENBOOK", DELETE in its entirety and SUBSTITUTE with the following:

1. Seed, fertilizer, mulch, and other specified materials shall be applied on slopes by Method B described in 801-4.8.2. Method B Hydroseed shall be composed of materials as follows:
2. Hydroseed shall consist of a mixture of bonded fiber matrix, seed, commercial fertilizer, binder, and water. Mixture will be as specified as follows:
  - a) The hydro-mulch slurry mixes shall be applied in a two (2) step process which allows seed to be in close contact with soil. The hydro-mulch shall be applied at the following rates:
    - i. Step 1: Seed Application Hydro-mulch:

Bonded Fiber Matrix (BFM):	500 lbs. per acre.
Fertilizer (Pre-Plant12-12-12):	100 lbs. per acre
Water:	As required per manufacturer's instructions
Mycorrhizal Inoculum:	60 lbs. per acre.
Seed Mix:	Pure live seed in weights as indicated on plans
    - ii. Step 2: Erosion Control Hydromulch

Bonded Fiber Matrix (BFM):	2,500 lbs. per acre.
Water:	As required
3. Contractor must provide the Resident Engineer with seed "bag tags" and receipt forms prior to installation of hydroseed mixture. All bare spots shall be re-seeded and mulched by the Contractor within thirty days of the initial application.
4. The preferred time for performing seeding is between the dates of October 15 and November 30 or before the first substantial winter rains if this is not possible, seeding shall occur between October 15 and February 28. Since an irrigation system is specified for the slope areas, seeding of those areas can be performed between September 15 and March 15, if the site is ready for seeding.
5. Seeding shall be started only after weed eradication; soil preparation and finish grading has been completed and soil has been permitted to settle.
6. Floating: After finish grading, deep watering, the areas to be seeded shall be loosened to a depth of two inches, raked, and floated to the final finish grade by a standard method acceptable to the Resident Engineer/Project Biologist (Restoration Ecologist), with the finish surfaces left even and smooth, free from ridges and depressions and reasonably well firmed.
7. All seed shall be separated and containerized by species. Each species of seed shall be labeled with the species, purity, germination, percent live seed and quantity of the seed in pounds. Save all seed tags and provide to the Resident Engineer with a small sample of seed from the seed containers prior to mixing to verify the seed quality.

8. Seeding application is to be performed prior to application of the hydromulch so that seed is in direct contact with the soil.
9. The seed shall be evenly applied over the entire area at the rates indicated for each area. During the sowing, care shall be exercised to keep uniform seed spacing. Seeding shall not be performed during times when wind may cause uneven distribution of the seed.
10. "Install Bark Mulch (3-inch Depth)" shall be measured as CY. The contract CY price paid for "Install Bark Mulch (3-inch Depth)" shall include full compensation for furnishing all materials, labor, and tools to perform all work necessary to complete the "Install Bark Mulch (3-inch Depth)" described or specified in these Special Provisions and Contract Documents and no additional compensation will be allowed therefore.

**801-5.1 General.** To the "WHITEBOOK", ADD the following:

2. Contractor shall repair and/or relace any existing irrigation damaged during installation of sewer lines.
3. Contractor shall check and verify all site conditions, utilities, and services prior to trenching. Verify point of connection location prior to beginning of work.
4. "Repair/Replace Existing Irrigation Damaged by Construction" shall be measured as Each. The contract Each price paid for "Repair/Replace Existing Irrigation Damaged by Construction" shall include full compensation for furnishing all materials, labor, and tools to perform all work necessary to complete the "Repair/Replace Existing Irrigation Damaged by Construction" described or specified in these Special Provisions and Contract Documents and no additional compensation will be allowed therefore.

**ADD:**

**801-6.1 Perform Agricultural Soils Tests and Percolation Tests**

1. "Perform Agricultural Soils Tests and Percolation Tests" shall be measured as Each. The contract Each price paid for "Perform Agricultural Soils Tests and Percolation Tests" shall include full compensation for furnishing all materials, labor, and tools to perform all work necessary to complete the "Perform Agricultural Soils Tests and Percolation Tests" described or specified in these Special Provisions and Contract Documents and no additional compensation will be allowed therefore.

**801-8 PAYMENT.** To the "GREENBOOK", ADD the following:

1. "Plant Establishment Period (90 Calendar Days )" shall be measured as a Each. The contract Each price paid for "Plant Establishment Period (90 Calendar Days)" shall include full compensation for furnishing all maintenance materials, labor, tools, equipment and performing all work necessary to complete, maintain, and warrantee the planting described or specified in the

contract documents for a duration of 90 days, including watering, supplemental watering, monitoring, weeding, replacing dead or diseased material, soils testing and recommended soil amendments; and maintaining of tree stakes, protective fencing, mulch, root barrier, pea gravel, to the aforementioned items and performing all work necessary to complete the maintenance Work described or specified in these Special Provisions and Contract Documents and no additional compensation will be allowed therefore.

2. "Plant Establishment Period (120 Calendar Days)" shall be measured as a Each. The contract Each price paid for "Plant Establishment Period (120 Calendar Days )" shall include full compensation for furnishing all maintenance materials, labor, tools, equipment and performing all work necessary to complete, maintain, and warrantee the planting described or specified in the contract documents for a duration of 120 days, including watering, supplemental watering, monitoring, weeding, replacing dead or diseased material, soils testing and recommended soil amendments; and maintaining of tree stakes, protective fencing, mulch, root barrier, pea gravel, to the aforementioned items and performing all work necessary to complete the maintenance Work described or specified in these Special Provisions and Contract Documents and no additional compensation will be allowed therefore.

## **SECTION 802 – NATIVE HABITAT PROTECTION, INSTALLATION, MAINTENANCE, AND MONITORING**

**802-2.1 Project Biologist.** To the "WHITEBOOK", ADD the following:

5. You shall retain a qualified Project Biologist to perform biological monitoring Work for this Contract. You shall coordinate your activities and Schedule with the activities and schedules of the Project Biologist.

## **SECTION 901 – INSTALLATION AND CONNECTION**

**901-1.1.2.3 High-lining Removed by the Contractor.** To the "WHITEBOOK", Item 2, DELETE in its entirety and SUBSTITUTE with the following:

2. After removing all high-lining construction material and debris, you shall restore streets, curbs, gutters, sidewalks, fire hydrants, and other disturbed facilities in accordance with PART 4 - EXISTING IMPROVEMENTS. Street resurfacing shall be restored in accordance with the SDG-107, "Pavement Restoration for Asphalt Concrete Surfaced Streets - Major Excavation", SDG-108, "Pavement Restoration for Concrete Surfaced Streets and Alleys - Major Excavation" as included in **Appendix M – Standard Drawings**.

**901-2.4 Pavement Restoration.** To the "WHITEBOOK", Item 2, DELETE in its entirety and SUBSTITUTE with the following:

2. After the final connection is completed, you shall remove all temporary resurfacing, compact sub-grade and restore affected area with permanent resurfacing in accordance with the following City of San Diego Standard Drawings as included in **Appendix M - Standard Drawings**. Payment for pavement restoration, including influence area, shall be included in the associated Bid Items pertinent to the Work.
  - a) SDG-105, "Pavement Restoration General Notes"
  - b) SDG-107, "Pavement Restoration for Asphalt Concrete Surfaced Streets - Major Excavation"
  - c) SDG-108, "Pavement Restoration for Concrete Surfaced Streets and Alleys - Major Excavation"
  - d) SDG-117, "Pavement Restoration for Asphalt Concrete Surface Streets - Minor Excavation"
  - e) SDG-118, "Pavement Restoration for Concrete Surface Streets and Alleys - Minor Excavation"

**901-2.5 Payment.** To the "WHITEBOOK", Item 1, subitem g, and Item 3, DELETE in their entirety and SUBSTITUTE with the following:

- g) Pavement Restoration including influence area.
3. Traffic Control, saw cutting the trench area, trench caps, and other spot repairs in the vicinity of the disturbed area at each restored connection shall be included in the square foot Bid Item for "**Pavement Restoration for Final Connection**". Asphalt overlay Work shall be paid for under separate Bid Items.

#### **SECTION 1001 - CONSTRUCTION BEST MANAGEMENT PRACTICES (BMPs)**

**1001-1 GENERAL.** To the "WHITEBOOK", ADD the following:

8. Based on a preliminary assessment by the City, this Contract is subject to **WPCP**.
-

**SUPPLEMENTARY SPECIAL PROVISIONS**  
**APPENDICES**

**APPENDIX A**

**ADDENDUM TO MITIGATED NEGATIVE DECLARATION**





THE CITY OF SAN DIEGO

## ADDENDUM TO MITIGATED NEGATIVE DECLARATION

Project No. 697902  
Addendum to MND No. 255100  
SCH No. 2011091045

**SUBJECT: Bay Ho Improvements 2:** The project proposes to replace existing water and sewer mains along with road improvements within the public right of way and existing city easements. Construction of the project would be located along portions of Avati Drive, Barrows Street, Brillden Court, Cadden Way, Caflur Avenue, Conner Way, Driscoll Drive, Fox Place, Fryden Way, Geddes Drive, Hartman Way, Huerfano Avenue, Huerfano Court, Hunrichs Way, Kamloop Avenue, Karnes Way, La Crosse Avenue, Monair Drive, Moraga Avenue, Morena Boulevard, Moraga Court, North Star Drive, Nute Way, Paducah Drive, Peters Way, Plone Way, Raffee Drive, Slayden Way, Southview Drive, Stockett Way, Tacoma Street, Tenshaw Place, Wicoee Place, and Yucca Avenue rights-of-way. **APPLICANT:** The City of San Diego Engineering and Capital Projects Department.

### I. SUMMARY OF PROPOSED PROJECT

**Project Location:** The Project is located within the Clairemont Mesa Community Planning Area (Council District 2).

**Sewer Improvements:** The project would be located on Avati Drive between Morena Boulevard and Huerfano Avenue; along Huerfano Avenue between Avati Drive and Kamloop Avenue; Geddes Drive between Huerfano Avenue and Moraga Avenue; Kamloop Avenue between Moraga Avenue and Huerfano Avenue; La Crosse Avenue between Geddes Drive 265' NE of Geddes Drive; Karnes Way between Huerfano Avenue and Peters Way; Conner Way between Huerfano Avenue and Hartman Way; Nute Way between Huerfano Avenue and Conner Court; Stockett Way between Huerfano Avenue and Slayden Way; Plone Way between Huerfano Avenue and Driscoll Drive; Driscoll Drive between Huerfano Avenue and Plone Way; Moraga Avenue between Balboa Avenue and Monair Drive; Monair Drive between Moraga Avenue and Southview Drive; Southview Drive between Monair Drive to cul-de-sac; Paducah Drive between Cadden Way and Moraga Place; Tenshaw Place between Huerfano Avenue and Barrows Street; Huerfano Court between Huerfano Avenue to end of cul-de-sac.

**Water Improvements:** The project would be located on Moraga Avenue between Ecochee Avenue and Hopi Place; Wicopee Place between Moraga Avenue and cul-de-sac; Caflur Avenue between Wicopee Place and Tacoma Street; Fox Place between Moraga Avenue and cul-de-sac; Moraga Court between Moraga Avenue and Avati Drive.

**Sewer Rehabilitation:** The project would be located on Cadden Way between Eichenlaub Street and Petunia Court; Raffee Drive between Eichenlaub Street and cul-de-sac; Raffee Drive between North Star Drive and Wheat Street; Barrows Street between Driscoll Drive and Tenshaw Place; Morena Boulevard between 2000' NW of Avati Drive and Avati Drive; within the easement at 4060 Huerfano Avenue and 4070 Huerfano Avenue; within the easement between Fryden Court and Driscoll Drive; within the easement NE of the intersection of Geddes Drive and Moraga Avenue; Avati Drive approximately 100' NW of Brillden Court; and Moraga Court between Moraga Avenue and Avati Drive.

**Project Description:**

The project proposes to replace existing water mains and sewer mains along with road improvements within the public right-of-way and existing city easements. Construction of Bay Ho Improvements 2 would consist of the installation of approximately 16,166 LF (3.06 miles) of 8-inch sewer mains, 2,924 LF (0.55 miles) of rehab sewer mains. The abandonment of 7,243 LF (1.37 miles) of 8 and 15 inch (VC) mains. The installation of approximately of 7,248 LF (1.37 miles) 8-inch and 12-inch AC water mains. The abandonment of approximately 2,520 (0.48 miles) of 8-inch and 12-inch water mains, including all associated water services, fire hydrants, laterals, manholes, replumbing, curb ramps, traffic control, trench restoration, pavement resurfacing and all other work and appurtenances in accordance with the specifications and drawings.

More specific descriptions of construction methods are as follow:

**Construction Staging:** The proposed project would also require staging areas, which would be temporarily located on the streets or in empty lots in various locations throughout construction.

**Total Disturbance:** The project would include 1.69 acres of total excavation with depths ranging from 3 feet to 34 feet below ground.

**Open Trenching:** The open trench method of construction will be used for complete replacement portions of the Project. Trenches are typically 3 feet wide and are hand dug (where necessary) or dug with excavators and similar large construction equipment. All trenching work would occur within City right-of-way and existing City easements.

**Rehabilitation:** Mainline rehabilitation will have minimum surface and subsurface disturbance at both ends of the mains. Disturbance would be limited to access to manholes for trenchless means and methods of rehabilitation. Small segments of new pipe will be installed along with manholes to replace plugs in order to complete the rehabilitation operations.

Abandonment: Mainline abandonment activities will have minimum surface/subsurface disturbance at both ends of the mains. Disturbance would be limited to removal of manholes and exposed main sections. Abandonment would occur within the City right-of-way and existing City Easements.

Potholing: Potholes will be required to locate existing utilities and determine if there are any utility conflicts.

## **II. ENVIRONMENTAL SETTING**

The Bay Ho Improvements 2 project would primarily occur within the developed public right-of-way and existing easements of previously disturbed areas managed by the City of San Diego Engineering and Capital Projects Department. The project is located in the Clairemont Mesa Community Plan. Surrounding land uses include existing residential, industrial park, and commercial developments. See attached Mitigated Negative Declaration for the environmental setting for the overall Citywide Pipeline Projects.

## **III. SUMMARY OF ORIGINAL PROJECT**

A Citywide Pipelines Projects Mitigated Negative Declaration (MND) No. 255100 was prepared by the City of San Diego's Development Services Department (DSD) and was certified by the City Council on November 30, 2011 (Resolution No. 307122). The Citywide Pipelines Projects MND provides for the inclusion of subsequent pipeline projects that are located within the public right-of-way and would not result in any direct impacts to sensitive biological resources. Pursuant to the City of San Diego's Municipal Code Section 128.0306 and Section 15164(c) of State CEQA Guidelines addenda to environmental documents are not required to be circulated for public review.

## **IV. ENVIRONMENTAL DETERMINATION**

The City previously prepared and certified the Citywide Pipeline Projects Mitigated Negative Declaration (MND) No. 255100/2011091045. Based on all available information in light of the entire record, the analysis in this Addendum, and pursuant to Section 15162 of the State CEQA Guidelines, the City has determined the following:

- There are no substantial changes proposed in the project which will require major revisions of the previous environmental document due to the involvement of new significant environmental effects or a substantial increase in the severity of previously identified significant effects;
- Substantial changes have not occurred with respect to the circumstances under which the project is undertaken which will require major revisions of the previous environmental document due to the involvement of new significant environmental effects or a substantial increase in the severity of previously identified significant effects; or
- There is no new information of substantial importance, which was not known and

could not have been known with the exercise of reasonable diligence at the time the previous environmental document was certified as complete or was adopted, shows any of the following:

- a. The project will have one or more significant effects not discussed in the previous environmental document;
- b. Significant effects previously examined will be substantially more severe than shown in the previous environmental document;
- c. Mitigation measures or alternatives previously found not to be feasible would in fact be feasible, and would substantially reduce one or more significant effects of the project, but the project proponents decline to adopt the mitigation measure or alternative; or
- d. Mitigation measures or alternatives which are considerably different from those analyzed in the previous environmental would substantially reduce one or more significant effects on the environment, but the project proponents decline to adopt the mitigation measure or alternative.

Based upon a review of the current project, none of the situations described in Sections 15162 and 15164 of the State CEQA Guidelines apply. No changes in circumstances have occurred, and no new information of substantial importance has manifested, which would result in new significant or substantially increased adverse impacts as a result of the project. Therefore, this Addendum has been prepared in accordance with Section 15164 of the CEQA State Guidelines. Public review of this Addendum is not required per CEQA.

## **V. IMPACT ANALYSIS**

The following includes the project-specific environmental review pursuant to the CEQA. The analysis in this document evaluates the adequacy of the MND relative to the project.

### **Archaeological Resources**

The Citywide Pipeline Project MND No. 255100 concluded that pipeline projects located within the public right-of-way and city easements could result in significant environmental impacts relating to archaeological resources, which included mitigation to reduce impacts to archaeological resources to below a level of significance. Portions of the Bay Ho Improvements 2 project would include excavation involved with open trenching within the same existing utility easements, or same alignment at the same or deeper depths than existing utilities. All roads and sidewalks impacted by trenching will be resurfaced and/or replaced-in-place.

A record search of the California Historic Resources Information System (CHRIS) digital database was conducted. Although no archaeological sites were identified within the alignments there are several large sites just to the west of the project. Because the project would require substantial excavation it was determined that the project could result in significant impacts to buried archaeological resources. To reduce potential archaeological

resource impacts to below a level of significance, all excavation would be monitored by a qualified archaeologist or archaeological monitor and a Native American monitor. Any significant archaeological resources encountered would be recovered and curated in accordance with the Mitigation Monitoring and Reporting Program (MMRP) detailed in Section V.

Based on the foregoing analysis and information, there is no evidence that the project would require a major change to the Mitigated Negative Declaration. The project would not result in any new significant impact, nor would a substantial increase in the severity of impacts from that described in the Mitigated Negative Declaration result.

### **Paleontological Resources**

Paleontological resources were analyzed in the MND 255100 which included mitigation to reduce impacts to paleontological resources to below a level of significance. Very Old Paralic Deposits, Ardath Shale and Scripps formations underlies the Bay Ho Improvements 2 project and with respect to paleontological fossil resource potential, the Scripps formation and Ardath Shale is assigned a high sensitivity and Very Old Paralic Deposits is assigned a moderate sensitivity. Based on the sensitivity of the affected formation and the proposed excavation depths, construction of the project could result in significant impacts to paleontological resources. To reduce this impact to below a level of significance, excavation at a depth of 10 or more feet would be monitored by a qualified paleontologist or paleontological monitor. Any significant paleontological resources encountered would be recovered and curated in accordance with the Mitigation Monitoring and Reporting Program (MMRP) detailed in Section V.

Based on the foregoing analysis and information, there is no evidence that the project would require a major change to the Mitigated Negative Declaration. The project would not result in any new significant impact, nor would a substantial increase in the severity of impacts from that described in the Mitigated Negative Declaration result.

### **LAND USE [MULTIPLE SPECIES CONSERVATION PROGRAM (MSCP)]**

The Citywide Pipelines Project MND No. 255100 determined that future pipeline projects could involve replacing and installing utility infrastructure in proximity to the City's Multi-Habitat Planning Area (MHPA). Activities which occur within 100 feet of the MHPA would be required to implement the MHPA Land Use Adjacency Guidelines (LUAG). Measures to reduce potential indirect impacts to the City's MHPA have been included in the MMRP contained within Section V of the Citywide Pipelines MND. Impacts were determined to be less than significant.

The project site is located outside of the Multi-Habitat Planning Area (MHPA) with a portion of the project located in the Stevenson Canyon. The project would rehabilitate two existing manholes (no. 110 and 111) and sewer main within the canyon area via trenchless construction methods. The scope of work for manhole rehabilitation would include coatings, ladder rung removal, structural lining, sealing of frame-chimney joints, replacements of the precast chimney cone, installation of manhole bowls to collect inflow, replacements of the manhole base, and chemical grouting. This work would not include excavation or ground-

disturbing activities. Vegetation trimming of non-native vegetation may be required to access both of the manholes (no. 110 and 111). Access to the site will be facilitated by an existing PUD canyon sewer path. Manhole no. 110 is located within a disturbed area and Manhole no. 111 is located within disturbed habitat. Avoidance of impacts is anticipated based on the trenchless construction and access to the manholes on foot and use of hand tools. Therefore, no direct impacts to biological resources are anticipated.

Based on the foregoing analysis and information, there is no evidence that the project would require a major change to the Mitigated Negative Declaration. The project would not result in any new significant impact, nor would a substantial increase in the severity of impacts from that described in the Mitigated Negative Declaration result.

## **VI. MITIGATION, MONITORING, AND REPORTING PROGRAM (MMRP) INCORPORATED INTO THE PROJECT**

### **ARCHAEOLOGICAL RESOURCES and NATIVE AMERICAN MONITORING**

#### **I. Prior to Permit Issuance or Bid Opening/Bid Award**

##### **A. Entitlements Plan Check**

1. Prior to permit issuance or Bid Opening/Bid Award, whichever is applicable, the Assistant Deputy Director (ADD) Environmental designee shall verify that the requirements for Archaeological Monitoring and Native American monitoring have been noted on the applicable construction documents through the plan check process.

##### **B. Letters of Qualification have been submitted to ADD**

1. Prior to Bid Award, the applicant shall submit a letter of verification to Mitigation Monitoring Coordination (MMC) identifying the Principal Investigator (PI) for the project and the names of all persons involved in the archaeological monitoring program, as defined in the City of San Diego Historical Resources Guidelines (HRG). If applicable, individuals involved in the archaeological monitoring program must have completed the 40-hour HAZWOPER training with certification documentation.
2. MMC will provide a letter to the applicant confirming the qualifications of the PI and all persons involved in the archaeological monitoring of the project meet the qualifications established in the HRG.
3. Prior to the start of work, the applicant must obtain written approval from MMC for any personnel changes associated with the monitoring program.

#### **II. Prior to Start of Construction**

##### **A. Verification of Records Search**

1. The PI shall provide verification to MMC that a site-specific records search (quarter-mile radius) has been completed. Verification includes, but is not limited to a copy of a confirmation letter from South Coastal Information Center, or, if the search was in-house, a letter of verification from the PI stating that the search was completed.
2. The letter shall introduce any pertinent information concerning expectations and probabilities of discovery during trenching and/or grading activities.

3. The PI may submit a detailed letter to MMC requesting a reduction to the ¼ mile radius.
- B. PI Shall Attend Precon Meetings
1. Prior to beginning any work that requires monitoring; the Applicant shall arrange a Precon Meeting that shall include the PI, Native American consultant/monitor (where Native American resources may be impacted), Construction Manager (CM) and/or Grading Contractor, Resident Engineer (RE), Building Inspector (BI), if appropriate, and MMC. The qualified Archaeologist and Native American Monitor shall attend any grading/excavation related Precon Meetings to make comments and/or suggestions concerning the Archaeological Monitoring program with the Construction Manager and/or Grading Contractor.
    - a. If the PI is unable to attend the Precon Meeting, the Applicant shall schedule a focused Precon Meeting with MMC, the PI, RE, CM or BI, if appropriate, prior to the start of any work that requires monitoring.
  2. Acknowledgement of Responsibility for Curation (CIP or Other Public Projects)  
The applicant shall submit a letter to MMC acknowledging their responsibility for the cost of curation associated with all phases of the archaeological monitoring program.
  3. Identify Areas to be Monitored
    - a. Prior to the start of any work that requires monitoring, the PI shall submit an Archaeological Monitoring Exhibit (AME) (with verification that the AME has been reviewed and approved by the Native American consultant/monitor when Native American resources may be impacted) based on the appropriate construction documents (reduced to 11x17) to MMC identifying the areas to be monitored including the delineation of grading/excavation limits.
    - b. The AME shall be based on the results of a site-specific records search as well as information regarding the age of existing pipelines, laterals and associated appurtenances and/or any known soil conditions (native or formation).
    - c. MMC shall notify the PI that the AME has been approved.
  4. When Monitoring Will Occur
    - a. Prior to the start of any work, the PI shall also submit a construction schedule to MMC through the RE indicating when and where monitoring will occur.
    - b. The PI may submit a detailed letter to MMC prior to the start of work or during construction requesting a modification to the monitoring program. This request shall be based on relevant information such as review of final construction documents which indicate conditions such as age of existing pipe to be replaced, depth of excavation and/or site graded to bedrock, etc., which may reduce or increase the potential for resources to be present.
  5. Approval of AME and Construction Schedule  
After approval of the AME by MMC, the PI shall submit to MMC written authorization of the AME and Construction Schedule from the CM.

### III. During Construction

- A. Monitor Shall be Present During Grading/Excavation/Trenching
1. The Archaeological Monitor shall be present full-time during all soil disturbing and grading/excavation/trenching activities which could result in impacts to archaeological resources as identified on the AME. The Construction Manager is responsible for notifying the RE, PI, and MMC of changes to any construction

activities such as in the case of a potential safety concern within the area being monitored. In certain circumstances OSHA safety requirements may necessitate modification of the AME.

2. The Native American consultant/monitor shall determine the extent of their presence during soil disturbing and grading/excavation/trenching activities based on the AME and provide that information to the PI and MMC. If prehistoric resources are encountered during the Native American consultant/monitor's absence, work shall stop and the Discovery Notification Process detailed in Section III.B-C and IV.A-D shall commence.
3. The PI may submit a detailed letter to MMC during construction requesting a modification to the monitoring program when a field condition such as modern disturbance post-dating the previous grading/trenching activities, presence of fossil formations, or when native soils are encountered that may reduce or increase the potential for resources to be present.
4. The archaeological and Native American consultant/monitor shall document field activity via the Consultant Site Visit Record (CSVSR). The CSVSR's shall be faxed by the CM to the RE the first day of monitoring, the last day of monitoring, monthly (Notification of Monitoring Completion), and in the case of ANY discoveries. The RE shall forward copies to MMC.

B. Discovery Notification Process

1. In the event of a discovery, the Archaeological Monitor shall direct the contractor to temporarily divert all soil disturbing activities, including but not limited to digging, trenching, excavating or grading activities in the area of discovery and in the area reasonably suspected to overlay adjacent resources and immediately notify the RE or BI, as appropriate.
2. The Monitor shall immediately notify the PI (unless Monitor is the PI) of the discovery.
3. The PI shall immediately notify MMC by phone of the discovery, and shall also submit written documentation to MMC within 24 hours by fax or email with photos of the resource in context, if possible.
4. No soil shall be exported off-site until a determination can be made regarding the significance of the resource specifically if Native American resources are encountered.

C. Determination of Significance

1. The PI and Native American consultant/monitor, where Native American resources are discovered shall evaluate the significance of the resource. If Human Remains are involved, follow protocol in Section IV below.
  - a. The PI shall immediately notify MMC by phone to discuss significance determination and shall also submit a letter to MMC indicating whether additional mitigation is required.
  - b. If the resource is significant, the PI shall submit an Archaeological Data Recovery Program (ADRP) and obtain written approval of the program from MMC, CM and RE. ADRP and any mitigation must be approved by MMC, RE and/or CM before ground disturbing activities in the area of discovery will be allowed to resume. Note: If a unique archaeological site is also an historical resource as defined in CEQA Section 15064.5, then the limits on the amount(s) that a project applicant



may be required to pay to cover mitigation costs as indicated in CEQA Section 21083.2 shall not apply.

- (1). Note: For pipeline trenching and other linear projects in the public Right-of-Way, the PI shall implement the Discovery Process for Pipeline Trenching projects identified below under "D."
- c. If the resource is not significant, the PI shall submit a letter to MMC indicating that artifacts will be collected, curated, and documented in the Final Monitoring Report. The letter shall also indicate that that no further work is required.
  - (1). Note: For Pipeline Trenching and other linear projects in the public Right-of-Way, if the deposit is limited in size, both in length and depth; the information value is limited and is not associated with any other resource; and there are no unique features/artifacts associated with the deposit, the discovery should be considered not significant.
  - (2). Note, for Pipeline Trenching and other linear projects in the public Right-of-Way, if significance cannot be determined, the Final Monitoring Report and Site Record (DPR Form 523A/B) shall identify the discovery as Potentially Significant.
- D. Discovery Process for Significant Resources - Pipeline Trenching and other Linear Projects in the Public Right-of-Way

The following procedure constitutes adequate mitigation of a significant discovery encountered during pipeline trenching activities or for other linear project types within the Public Right-of-Way including but not limited to excavation for jacking pits, receiving pits, laterals, and manholes to reduce impacts to below a level of significance:

1. Procedures for documentation, curation and reporting
  - a. One hundred percent of the artifacts within the trench alignment and width shall be documented in-situ, to include photographic records, plan view of the trench and profiles of side walls, recovered, photographed after cleaning and analyzed and curated. The remainder of the deposit within the limits of excavation (trench walls) shall be left intact.
  - b. The PI shall prepare a Draft Monitoring Report and submit to MMC via the RE as indicated in Section VI-A.
  - c. The PI shall be responsible for recording (on the appropriate State of California Department of Park and Recreation forms-DPR 523 A/B) the resource(s) encountered during the Archaeological Monitoring Program in accordance with the City's Historical Resources Guidelines. The DPR forms shall be submitted to the South Coastal Information Center for either a Primary Record or SDI Number and included in the Final Monitoring Report.
  - d. The Final Monitoring Report shall include a recommendation for monitoring of any future work in the vicinity of the resource.

#### **IV. Discovery of Human Remains**

If human remains are discovered, work shall halt in that area and no soil shall be exported off-site until a determination can be made regarding the provenance of the human remains; and the following procedures as set forth in CEQA Section 15064.5(e), the California Public Resources Code (Sec. 5097.98) and State Health and Safety Code (Sec. 7050.5) shall be undertaken:

- A. Notification

1. Archaeological Monitor shall notify the RE or BI as appropriate, MMC, and the PI, if the Monitor is not qualified as a PI. MMC will notify the appropriate Senior Planner in the Environmental Analysis Section (EAS) of the Development Services Department to assist with the discovery notification process.
  2. The PI shall notify the Medical Examiner after consultation with the RE, either in person or via telephone.
- B. Isolate discovery site
1. Work shall be directed away from the location of the discovery and any nearby area reasonably suspected to overlay adjacent human remains until a determination can be made by the Medical Examiner in consultation with the PI concerning the provenience of the remains.
  2. The Medical Examiner, in consultation with the PI, will determine the need for a field examination to determine the provenience.
  3. If a field examination is not warranted, the Medical Examiner will determine with input from the PI, if the remains are or are most likely to be of Native American origin.
- C. If Human Remains ARE determined to be Native American
1. The Medical Examiner will notify the Native American Heritage Commission (NAHC) within 24 hours. By law, ONLY the Medical Examiner can make this call.
  2. NAHC will immediately identify the person or persons determined to be the Most Likely Descendent (MLD) and provide contact information.
  3. The MLD will contact the PI within 24 hours or sooner after the Medical Examiner has completed coordination, to begin the consultation process in accordance with CEQA Section 15064.5(e), the California Public Resources and Health & Safety Codes.
  4. The MLD will have 48 hours to make recommendations to the property owner or representative, for the treatment or disposition with proper dignity, of the human remains and associated grave goods.
  5. Disposition of Native American Human Remains will be determined between the MLD and the PI, and, if:
    - a. The NAHC is unable to identify the MLD, OR the MLD failed to make a recommendation within 48 hours after being granted access to the site, OR;
    - b. The landowner or authorized representative rejects the recommendation of the MLD and mediation in accordance with PRC 5097.94 (k) by the NAHC fails to provide measures acceptable to the landowner, the landowner shall reinter the human remains and items associated with Native American human remains with appropriate dignity on the property in a location not subject to further and future subsurface disturbance, THEN
    - c. To protect these sites, the landowner shall do one or more of the following:
      - (1) Record the site with the NAHC;
      - (2) Record an open space or conservation easement; or
      - (3) Record a document with the County. The document shall be titled "Notice of Reinterment of Native American Remains" and shall include a legal description of the property, the name of the property owner, and the owner's acknowledged signature, in addition to any other information required by PRC 5097.98. The document shall be indexed as a notice under the name of the owner.
    - d. Upon the discovery of multiple Native American human remains during a ground disturbing land development activity, the landowner may agree that additional

conferral with descendants is necessary to consider culturally appropriate treatment of multiple Native American human remains. Culturally appropriate treatment of such a discovery may be ascertained from review of the site utilizing cultural and archaeological standards. Where the parties are unable to agree on the appropriate treatment measures the human remains and items associated and buried with Native American human remains shall be reinterred with appropriate dignity, pursuant to Section 5.c., above.

- D. If Human Remains are NOT Native American
  - 1. The PI shall contact the Medical Examiner and notify them of the historic era context of the burial.
  - 2. The Medical Examiner will determine the appropriate course of action with the PI and City staff (PRC 5097.98).
  - 3. If the remains are of historic origin, they shall be appropriately removed and conveyed to the San Diego Museum of Man for analysis. The decision for internment of the human remains shall be made in consultation with MMC, EAS, the applicant/landowner, any known descendant group, and the San Diego Museum of Man.

**V. Night and/or Weekend Work**

- A. If night and/or weekend work is included in the contract
  - 1. When night and/or weekend work is included in the contract package, the extent and timing shall be presented and discussed at the precon meeting.
  - 2. The following procedures shall be followed.
    - a. No Discoveries  
In the event that no discoveries were encountered during night and/or weekend work, the PI shall record the information on the CSVr and submit to MMC via fax by 8AM of the next business day.
    - b. Discoveries  
All discoveries shall be processed and documented using the existing procedures detailed in Sections III - During Construction, and IV - Discovery of Human Remains. Discovery of human remains shall always be treated as a significant discovery.
    - c. Potentially Significant Discoveries  
If the PI determines that a potentially significant discovery has been made, the procedures detailed under Section III - During Construction and IV-Discovery of Human Remains shall be followed.
    - d. The PI shall immediately contact the RE and MMC, or by 8AM of the next business day to report and discuss the findings as indicated in Section III-B, unless other specific arrangements have been made.
- B. If night and/or weekend work becomes necessary during the course of construction
  - 1. The Construction Manager shall notify the RE, or BI, as appropriate, a minimum of 24 hours before the work is to begin.
  - 2. The RE, or BI, as appropriate, shall notify MMC immediately.
- C. All other procedures described above shall apply, as appropriate.

**VI. Post Construction**

- A. Submittal of Draft Monitoring Report

1. The PI shall submit two copies of the Draft Monitoring Report (even if negative), prepared in accordance with the Historical Resources Guidelines (Appendix C/D) which describes the results, analysis, and conclusions of all phases of the Archaeological Monitoring Program (with appropriate graphics) to MMC via the RE for review and approval within 90 days following the completion of monitoring. It should be noted that if the PI is unable to submit the Draft Monitoring Report within the allotted 90-day timeframe as a result of delays with analysis, special study results or other complex issues, a schedule shall be submitted to MMC establishing agreed due dates and the provision for submittal of monthly status reports until this measure can be met.
    - a. For significant archaeological resources encountered during monitoring, the Archaeological Data Recovery Program or Pipeline Trenching Discovery Process shall be included in the Draft Monitoring Report.
    - b. Recording Sites with State of California Department of Parks and Recreation  
The PI shall be responsible for recording (on the appropriate State of California Department of Park and Recreation forms-DPR 523 A/B) any significant or potentially significant resources encountered during the Archaeological Monitoring Program in accordance with the City's Historical Resources Guidelines, and submittal of such forms to the South Coastal Information Center with the Final Monitoring Report.
  2. MMC shall return the Draft Monitoring Report to the PI via the RE for revision or, for preparation of the Final Report.
  3. The PI shall submit revised Draft Monitoring Report to MMC via the RE for approval.
  4. MMC shall provide written verification to the PI of the approved report.
  5. MMC shall notify the RE or BI, as appropriate, of receipt of all Draft Monitoring Report submittals and approvals.
- B. Handling of Artifacts
1. The PI shall be responsible for ensuring that all cultural remains collected are cleaned and catalogued
  2. The PI shall be responsible for ensuring that all artifacts are analyzed to identify function and chronology as they relate to the history of the area; that faunal material is identified as to species; and that specialty studies are completed, as appropriate.
- C. Curation of artifacts: Accession Agreement and Acceptance Verification
1. The PI shall be responsible for ensuring that all artifacts associated with the survey, testing and/or data recovery for this project are permanently curated with an appropriate institution. This shall be completed in consultation with MMC and the Native American representative, as applicable.
  2. When applicable to the situation, the PI shall include written verification from the Native American consultant/monitor indicating that Native American resources were treated in accordance with state law and/or applicable agreements. If the resources were reinterred, verification shall be provided to show what protective measures were taken to ensure no further disturbance occurs in accordance with Section IV – Discovery of Human Remains, Subsection C.
  3. The PI shall submit the Accession Agreement and catalogue record(s) to the RE or BI, as appropriate for donor signature with a copy submitted to MMC.
  4. The RE or BI, as appropriate shall obtain signature on the Accession Agreement and shall return to PI with copy submitted to MMC.

5. The PI shall include the Acceptance Verification from the curation institution in the Final Monitoring Report submitted to the RE or BI and MMC.
- D. Final Monitoring Report(s)
1. The PI shall submit one copy of the approved Final Monitoring Report to the RE or BI as appropriate, and one copy to MMC (even if negative), within 90 days after notification from MMC of the approved report.
  2. The RE shall, in no case, issue the Notice of Completion until receiving a copy of the approved Final Monitoring Report from MMC which includes the Acceptance Verification from the curation institution.

## **PALEONTOLOGICAL RESOURCES**

### **I. Prior to Permit Issuance or Bid Opening/Bid Award**

#### **A. Entitlements Plan Check**

1. Prior to permit issuance or Bid Opening/Bid Award, whichever is applicable, the Assistant Deputy Director (ADD) Environmental designee shall verify that the requirements for Paleontological Monitoring have been noted on the appropriate construction documents.

#### **B. Letters of Qualification have been submitted to ADD**

1. Prior to Bid Award, the applicant shall submit a letter of verification to Mitigation Monitoring Coordination (MMC) identifying the Principal Investigator (PI) for the project and the names of all persons involved in the paleontological monitoring program, as defined in the City of San Diego Paleontology Guidelines.
2. MMC will provide a letter to the applicant confirming the qualifications of the PI and all persons involved in the paleontological monitoring of the project.
3. Prior to the start of work, the applicant shall obtain approval from MMC for any personnel changes associated with the monitoring program.

### **II. Prior to Start of Construction**

#### **A. Verification of Records Search**

1. The PI shall provide verification to MMC that a site specific records search has been completed. Verification includes, but is not limited to a copy of a confirmation letter from San Diego Natural History Museum, other institution or, if the search was in-house, a letter of verification from the PI stating that the search was completed.
2. The letter shall introduce any pertinent information concerning expectations and probabilities of discovery during trenching and/or grading activities.

#### **B. PI Shall Attend Precon Meetings**

1. Prior to beginning any work that requires monitoring, the Applicant shall arrange a Precon Meeting that shall include the PI, Construction Manager (CM) and/or Grading Contractor, Resident Engineer (RE), Building Inspector (BI), if appropriate, and MMC. The qualified paleontologist shall attend any grading/excavation related Precon Meetings to make comments and/or suggestions concerning the Paleontological Monitoring program with the Construction Manager and/or Grading Contractor.
  - a. If the PI is unable to attend the Precon Meeting, the Applicant shall schedule a focused Precon Meeting with MMC, the PI, RE, CM or BI, if appropriate, prior to the start of any work that requires monitoring.

2. Acknowledgement of Responsibility for Curation (CIP or Other Public Projects)  
The applicant shall submit a letter to MMC acknowledging their responsibility for the cost of curation associated with all phases of the paleontological monitoring program.
3. Identify Areas to be Monitored
  - a. Prior to the start of any work that requires monitoring, the PI shall submit a Paleontological Monitoring Exhibit (PME) based on the appropriate construction documents (reduced to 11x17) to MMC for approval identifying the areas to be monitored including the delineation of grading/excavation limits. Monitoring shall begin at depths below 10 feet from existing grade or as determined by the PI in consultation with MMC. The determination shall be based on site specific records search data which supports monitoring at depths less than ten feet.
  - b. The PME shall be based on the results of a site specific records search as well as information regarding existing known soil conditions (native or formation).
  - c. MMC shall notify the PI that the PME has been approved.
4. When Monitoring Will Occur
  - a. Prior to the start of any work, the PI shall also submit a construction schedule to MMC through the RE indicating when and where monitoring will occur.
  - b. The PI may submit a detailed letter to MMC prior to the start of work or during construction requesting a modification to the monitoring program. This request shall be based on relevant information such as review of final construction documents which indicate conditions such as depth of excavation and/or site graded to bedrock, presence or absence of fossil resources, etc., which may reduce or increase the potential for resources to be present.
5. Approval of PME and Construction Schedule  
After approval of the PME by MMC, the PI shall submit to MMC written authorization of the PME and Construction Schedule from the CM.

### III. During Construction

- A. Monitor Shall be Present During Grading/Excavation/Trenching
  1. The monitor shall be present full-time during grading/excavation/trenching activities including, but not limited to mainline, laterals, jacking and receiving pits, services and all other appurtenances associated with underground utilities as identified on the PME that could result in impacts to formations with high and/or moderate resource sensitivity. **The Construction Manager is responsible for notifying the RE, PI, and MMC of changes to any construction activities such as in the case of a potential safety concern within the area being monitored. In certain circumstances OSHA safety requirements may necessitate modification of the PME.**
  2. The PI may submit a detailed letter to MMC during construction requesting a modification to the monitoring program when a field condition such as trenching activities that do not encounter formational soils as previously assumed, and/or when unique/unusual fossils are encountered, which may reduce or increase the potential for resources to be present.
  3. The monitor shall document field activity via the Consultant Site Visit Record (CSVR). The CSVR's shall be faxed by the CM to the RE the first day of monitoring, the last day of monitoring, monthly (**Notification of Monitoring Completion**), and in the case of ANY discoveries. The RE shall forward copies to MMC.

B. Discovery Notification Process

1. In the event of a discovery, the Paleontological Monitor shall direct the contractor to temporarily divert trenching activities in the area of discovery and immediately notify the RE or BI, as appropriate.
2. The Monitor shall immediately notify the PI (unless Monitor is the PI) of the discovery.
3. The PI shall immediately notify MMC by phone of the discovery, and shall also submit written documentation to MMC within 24 hours by fax or email with photos of the resource in context, if possible.

C. Determination of Significance

1. The PI shall evaluate the significance of the resource.
  - a. The PI shall immediately notify MMC by phone to discuss significance determination and shall also submit a letter to MMC indicating whether additional mitigation is required. The determination of significance for fossil discoveries shall be at the discretion of the PI.
  - b. If the resource is significant, the PI shall submit a Paleontological Recovery Program (PRP) and obtain written approval of the program from MMC, MC and/or RE. PRP and any mitigation must be approved by MMC, RE and/or CM before ground disturbing activities in the area of discovery will be allowed to resume.
    - (1). Note: For pipeline trenching projects only, the PI shall implement the Discovery Process for Pipeline Trenching projects identified below under "D."
  - c. If resource is not significant (e.g., small pieces of broken common shell fragments or other scattered common fossils) the PI shall notify the RE, or BI as appropriate, that a non-significant discovery has been made. The Paleontologist shall continue to monitor the area without notification to MMC unless a significant resource is encountered.
  - d. The PI shall submit a letter to MMC indicating that fossil resources will be collected, curated, and documented in the Final Monitoring Report. The letter shall also indicate that no further work is required.
    - (1). Note: For Pipeline Trenching Projects Only. If the fossil discovery is limited in size, both in length and depth; the information value is limited and there are no unique fossil features associated with the discovery area, then the discovery should be considered not significant.
    - (2). Note, for Pipeline Trenching Projects Only: If significance can not be determined, the Final Monitoring Report and Site Record shall identify the discovery as Potentially Significant.

D. Discovery Process for Significant Resources - Pipeline Trenching Projects

The following procedure constitutes adequate mitigation of a significant discovery encountered during pipeline trenching activities including but not limited to excavation for jacking pits, receiving pits, laterals, and manholes to reduce impacts to below a level of significance.

1. Procedures for documentation, curation and reporting
  - a. One hundred percent of the fossil resources within the trench alignment and width shall be documented in-situ photographically, drawn in plan view (trench and profiles of side walls), recovered from the trench and photographed after

- cleaning, then analyzed and curated consistent with Society of Invertebrate Paleontology Standards. The remainder of the deposit within the limits of excavation (trench walls) shall be left intact and so documented.
- b. The PI shall prepare a Draft Monitoring Report and submit to MMC via the RE as indicated in Section VI-A.
  - c. The PI shall be responsible for recording (on the appropriate forms for the San Diego Natural History Museum) the resource(s) encountered during the Paleontological Monitoring Program in accordance with the City's Paleontological Guidelines. The forms shall be submitted to the San Diego Natural History Museum and included in the Final Monitoring Report.
  - d. The Final Monitoring Report shall include a recommendation for monitoring of any future work in the vicinity of the resource.

#### **IV. Night and/or Weekend Work**

- A. If night and/or weekend work is included in the contract
  1. When night and/or weekend work is included in the contract package, the extent and timing shall be presented and discussed at the precon meeting.
  2. The following procedures shall be followed.
    - a. No Discoveries  
In the event that no discoveries were encountered during night and/or weekend work, The PI shall record the information on the CSVr and submit to MMC via the RE via fax by 8AM on the next business day.
    - b. Discoveries  
All discoveries shall be processed and documented using the existing procedures detailed in Sections III - During Construction.
    - c. Potentially Significant Discoveries  
If the PI determines that a potentially significant discovery has been made, the procedures detailed under Section III - During Construction shall be followed.
    - d. The PI shall immediately contact the RE and MMC, or by 8AM on the next business day to report and discuss the findings as indicated in Section III-B, unless other specific arrangements have been made.
- B. If night and/or weekend work becomes necessary during the course of construction
  1. The Construction Manager shall notify the RE, or BI, as appropriate, a minimum of 24 hours before the work is to begin.
  2. The RE, or BI, as appropriate, shall notify MMC immediately.
- C. All other procedures described above shall apply, as appropriate.

#### **V. Post Construction**

- A. Preparation and Submittal of Draft Monitoring Report
  1. The PI shall submit two copies of the Draft Monitoring Report (even if negative), prepared in accordance with the Paleontological Guidelines which describes the results, analysis, and conclusions of all phases of the Paleontological Monitoring Program (with appropriate graphics) to MMC via the RE for review and approval within 90 days following the completion of monitoring,
    - a. For significant paleontological resources encountered during monitoring, the Paleontological Recovery Program or Pipeline Trenching Discovery Process shall be included in the Draft Monitoring Report.



- b. Recording Sites with the San Diego Natural History Museum
 

The PI shall be responsible for recording (on the appropriate forms) any significant or potentially significant fossil resources encountered during the Paleontological Monitoring Program in accordance with the City's Paleontological Guidelines, and submittal of such forms to the San Diego Natural History Museum with the Final Monitoring Report.
  - 2. MMC shall return the Draft Monitoring Report to the PI via the RE for revision or, for preparation of the Final Report.
  - 3. The PI shall submit revised Draft Monitoring Report to MMC via the RE for approval.
  - 4. MMC shall provide written verification to the PI of the approved report.
  - 5. MMC shall notify the RE or BI, as appropriate, of receipt of all Draft Monitoring Report submittals and approvals.
- B. Handling of Fossil Remains
  - 1. The PI shall be responsible for ensuring that all fossil remains collected are cleaned and catalogued.
- C. Curation of artifacts: Deed of Gift and Acceptance Verification
  - 1. The PI shall be responsible for ensuring that all fossil remains associated with the monitoring for this project are permanently curated with an appropriate institution.
  - 2. The PI shall submit the Deed of Gift and catalogue record(s) to the RE or BI, as appropriate for donor signature with a copy submitted to MMC.
  - 3. The RE or BI, as appropriate shall obtain signature on the Deed of Gift and shall return to PI with copy submitted to MMC.
  - 4. The PI shall include the Acceptance Verification from the curation institution in the Final Monitoring Report submitted to the RE or BI and MMC.
- D. Final Monitoring Report(s)
  - 1. The PI shall submit two copies of the Final Monitoring Report to MMC (even if negative), within 90 days after notification from MMC of the approved report.
  - 2. The RE shall, in no case, issue the Notice of Completion until receiving a copy of the approved Final Monitoring Report from MMC which includes the Acceptance Verification from the curation institution.

## VII. IMPACT SIGNIFICANCE

The MND identified that all impacts would be mitigated to below a level of significance through mitigation. This Addendum also identifies that all significant project impacts would be mitigated to below a level of significance, consistent with the previously certified MND.

## VIII. CERTIFICATION

Copies of the addendum, the adopted MND, the MMRP, and associated project-specific technical appendices, if any, may be accessed on the City's CEQA webpage at <https://www.sandiego.gov/ceqa/final>.

*Jeff Szymanski*

Jeff Szymanski

Senior Planner

Development Services Department

February 1, 2023

Date of Final Report

Analyst: Rhonda Benally

Attachments: Figure 1: Location Map

Mitigated Negative Declaration No. 255100/SCH No. 2011091045

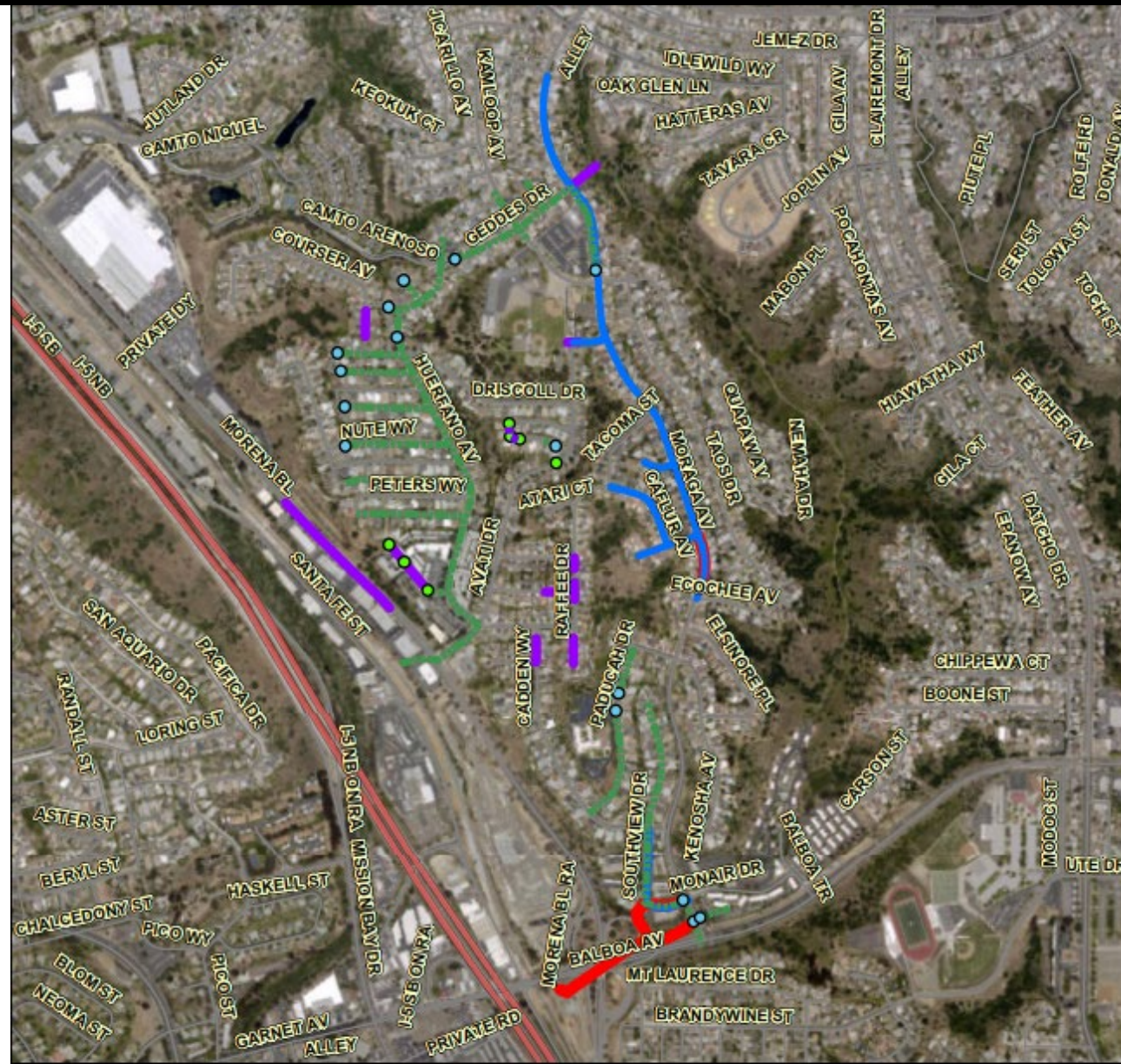

**Legend**

- Repair Manhole
- New Manhole
- Proposed Sewer Main
- Proposed Water Main
- Sewer Main Rehab
- Abandonment pipe



**Bay Ho Improvements**



**Site Plan**

**Environmental Analysis Section Project No. 697902**  
 CITY OF SAN DIEGO · DEVELOPMENT SERVICES DEPARTMENT

Bay Ho Improv 2  
 K-24-2247-DBB-3

**Figure 2**

**APPENDIX B**  
**FIRE HYDRANT METER PROGRAM**

<b>CITY OF SAN DIEGO CALIFORNIA DEPARTMENT INSTRUCTIONS</b>	<b>NUMBER DI 55.27</b>	<b>DEPARTMENT Water Department</b>
<b>SUBJECT  FIRE HYDRANT METER PROGRAM (FORMERLY: CONSTRUCTION METER PROGRAM)</b>	<b>PAGE 1 OF 10</b>	<b>EFFECTIVE DATE  October 15, 2002</b>
	<b>SUPERSEDES DI 55.27</b>	<b>DATED April 21, 2000</b>

1. **PURPOSE**

1.1 To establish a Departmental policy and procedure for issuance, proper usage and charges for fire hydrant meters.

2. **AUTHORITY**

2.1 All authorities and references shall be current versions and revisions.

2.2 San Diego Municipal Code (NC) Chapter VI, Article 7, Sections 67.14 and 67.15

2.3 Code of Federal Regulations, Safe Drinking Water Act of 1986

2.4 California Code of Regulations, Titles 17 and 22

2.5 California State Penal Code, Section 498B.0

2.6 State of California Water Code, Section 110, 500-6, and 520-23

2.7 Water Department Director

**Reference**

2.8 State of California Guidance Manual for Cross Connection Programs

2.9 American Water Works Association Manual M-14, Recommended Practice for Backflow Prevention

2.10 American Water Works Association Standards for Water Meters

2.11 U.S.C. Foundation for Cross Connection Control and Hydraulic Research Manual

3. **DEFINITIONS**

3.1 **Fire Hydrant Meter:** A portable water meter which is connected to a fire hydrant for the purpose of temporary use. (These meters are sometimes referred to as Construction Meters.)

<b>CITY OF SAN DIEGO CALIFORNIA DEPARTMENT INSTRUCTIONS</b>	<b>NUMBER DI 55.27</b>	<b>DEPARTMENT Water Department</b>
<b>SUBJECT  FIRE HYDRANT METER PROGRAM (FORMERLY: CONSTRUCTION METER PROGRAM)</b>	<b>PAGE 2 OF 10</b>	<b>EFFECTIVE DATE  October 15, 2002</b>
	<b>SUPERSEDES DI 55.27</b>	<b>DATED April 21, 2000</b>

- 3.2 **Temporary Water Use:** Water provided to the customer for no longer than twelve (12) months.
- 3.3 **Backflow Preventor:** A Reduced Pressure Principal Assembly connected to the outlet side of a Fire Hydrant Meter.

4. **POLICY**

- 4.1 The Water Department shall collect a deposit from every customer requiring a fire hydrant meter and appurtenances prior to providing the meter and appurtenances (see Section 7.1 regarding the Fees and Deposit Schedule). The deposit is refundable upon the termination of use and return of equipment and appurtenances in good working condition.
- 4.2 Fire hydrant meters will have a 2 ½" swivel connection between the meter and fire hydrant. The meter shall not be connected to the 4" port on the hydrant. All Fire Hydrant Meters issued shall have a Reduced Pressure Principle Assembly (RP) as part of the installation. Spanner wrenches are the only tool allowed to turn on water at the fire hydrant.
- 4.3 The use of private hydrant meters on City hydrants is prohibited, with exceptions as noted below. All private fire hydrant meters are to be phased out of the City of San Diego. All customers who wish to continue to use their own fire hydrant meters must adhere to the following conditions:
  - a. Meters shall meet all City specifications and American Water Works Association (AWWA) standards.
  - b. Customers currently using private fire hydrant meters in the City of San Diego water system will be allowed to continue using the meter under the following conditions:
    - 1. The customer must submit a current certificate of accuracy and calibration results for private meters and private backflows annually to the City of San Diego, Water Department, Meter Shop.

<b>CITY OF SAN DIEGO CALIFORNIA DEPARTMENT INSTRUCTIONS</b>	<b>NUMBER DI 55.27</b>	<b>DEPARTMENT Water Department</b>
<b>SUBJECT  FIRE HYDRANT METER PROGRAM (FORMERLY: CONSTRUCTION METER PROGRAM)</b>	<b>PAGE 3 OF 10</b>	<b>EFFECTIVE DATE  October 15, 2002</b>
	<b>SUPERSEDES DI 55.27</b>	<b>DATED April 21, 2000</b>

2. The meter must be properly identifiable with a clearly labeled serial number on the body of the fire hydrant meter. The serial number shall be plainly stamped on the register lid and the main casing. Serial numbers shall be visible from the top of the meter casing and the numbers shall be stamped on the top of the inlet casing flange.
3. All meters shall be locked to the fire hydrant by the Water Department, Meter Section (see Section 4.7).
4. All meters shall be read by the Water Department, Meter Section (see Section 4.7).
5. All meters shall be relocated by the Water Department, Meter Section (see Section 4.7).
6. These meters shall be tested on the anniversary of the original test date and proof of testing will be submitted to the Water Department, Meter Shop, on a yearly basis. If not tested, the meter will not be allowed for use in the City of San Diego.
7. All private fire hydrant meters shall have backflow devices attached when installed.
8. The customer must maintain and repair their own private meters and private backflows.
9. The customer must provide current test and calibration results to the Water Department, Meter Shop after any repairs.
10. When private meters are damaged beyond repair, these private meters will be replaced by City owned fire hydrant meters.

<b>CITY OF SAN DIEGO CALIFORNIA DEPARTMENT INSTRUCTIONS</b>	<b>NUMBER DI 55.27</b>	<b>DEPARTMENT Water Department</b>
<b>SUBJECT  FIRE HYDRANT METER PROGRAM (FORMERLY: CONSTRUCTION METER PROGRAM)</b>	<b>PAGE 4 OF 10</b>	<b>EFFECTIVE DATE  October 15, 2002</b>
	<b>SUPERSEDES DI 55.27</b>	<b>DATED April 21, 2000</b>

11. When a private meter malfunctions, the customer will be notified and the meter will be removed by the City and returned to the customer for repairs. Testing and calibration results shall be given to the City prior to any re-installation.
  12. The register shall be hermetically sealed straight reading and shall be readable from the inlet side. Registration shall be in hundred cubic feet.
  13. The outlet shall have a 2 ½ “National Standards Tested (NST) fire hydrant male coupling.
  14. Private fire hydrant meters shall not be transferable from one contracting company to another (i.e. if a company goes out of business or is bought out by another company).
- 4.4 All fire hydrant meters and appurtenances shall be installed, relocated and removed by the City of San Diego, Water Department. All City owned fire hydrant meters and appurtenances shall be maintained by the City of San Diego, Water Department, Meter Services.
- 4.5 If any fire hydrant meter is used in violation of this Department Instruction, the violation will be reported to the Code Compliance Section for investigation and appropriate action. Any customer using a fire hydrant meter in violation of the requirements set forth above is subject to fines or penalties pursuant to the Municipal Code, Section 67.15 and Section 67.37.
- 4.6 Conditions and Processes for Issuance of a Fire Hydrant Meter**
- Process for Issuance
- a. Fire hydrant meters shall only be used for the following purposes:
    1. Temporary irrigation purposes not to exceed one year.



<b>CITY OF SAN DIEGO CALIFORNIA DEPARTMENT INSTRUCTIONS</b>	<b>NUMBER DI 55.27</b>	<b>DEPARTMENT Water Department</b>
<b>SUBJECT  FIRE HYDRANT METER PROGRAM (FORMERLY: CONSTRUCTION METER PROGRAM)</b>	<b>PAGE 5 OF 10</b>	<b>EFFECTIVE DATE  October 15, 2002</b>
	<b>SUPERSEDES DI 55.27</b>	<b>DATED April 21, 2000</b>

2. Construction and maintenance related activities (see Tab 2).
  - b. No customer inside or outside the boundaries of the City of San Diego Water Department shall resell any portion of the water delivered through a fire hydrant by the City of San Diego Water Department.
  - c. The City of San Diego allows for the issuance of a temporary fire hydrant meter for a period not to exceed 12 months (365 days). An extension can only be granted in writing from the Water Department Director for up to 90 additional days. A written request for an extension by the consumer must be submitted at least 30 days prior to the 12 month period ending. No extension shall be granted to any customer with a delinquent account with the Water Department. No further extensions shall be granted.
  - d. Any customer requesting the issuance of a fire hydrant meter shall file an application with the Meter Section. The customer must complete a "Fire Hydrant Meter Application" (Tab 1) which includes the name of the company, the party responsible for payment, Social Security number and/or California ID, requested location of the meter (a detailed map signifying an exact location), local contact person, local phone number, a contractor's license (or a business license), description of specific water use, duration of use at the site and full name and address of the person responsible for payment.
  - e. At the time of the application the customer will pay their fees according to the schedule set forth in the Rate Book of Fees and Charges, located in the City Clerk's Office. All fees must be paid by check, money order or cashiers check, made payable to the City Treasurer. Cash will not be accepted.
  - f. No fire hydrant meters shall be furnished or relocated for any customer with a delinquent account with the Water Department.
  - g. After the fees have been paid and an account has been created, the

<b>CITY OF SAN DIEGO CALIFORNIA DEPARTMENT INSTRUCTIONS</b>	<b>NUMBER DI 55.27</b>	<b>DEPARTMENT Water Department</b>
<b>SUBJECT  FIRE HYDRANT METER PROGRAM (FORMERLY: CONSTRUCTION METER PROGRAM)</b>	<b>PAGE 6 OF 10</b>	<b>EFFECTIVE DATE  October 15, 2002</b>
	<b>SUPERSEDES DI 55.27</b>	<b>DATED April 21, 2000</b>

meter shall be installed within 48 hours (by the second business day). For an additional fee, at overtime rates, meters can be installed within 24 hours (within one business day).

#### 4.7 Relocation of Existing Fire Hydrant Meters

- a. The customer shall call the Fire Hydrant Meter Hotline (herein referred to as “Hotline”), a minimum of 24 hours in advance, to request the relocation of a meter. A fee will be charged to the existing account, which must be current before a work order is generated for the meter’s relocation.
- b. The customer will supply in writing the address where the meter is to be relocated (map page, cross street, etc). The customer must update the original Fire Hydrant Meter Application with any changes as it applies to the new location.
- c. Fire hydrant meters shall be read on a monthly basis. While fire hydrant meters and backflow devices are in service, commodity, base fee and damage charges, if applicable, will be billed to the customer on a monthly basis. If the account becomes delinquent, the meter will be removed.

#### 4.8 Disconnection of Fire Hydrant Meter

- a. After ten (10) months a “Notice of Discontinuation of Service” (Tab 3) will be issued to the site and the address of record to notify the customer of the date of discontinuance of service. An extension can only be granted in writing from the Water Department Director for up to 90 additional days (as stated in Section 4.6C) and a copy of the extension shall be forwarded to the Meter Shop Supervisor. If an extension has not been approved, the meter will be removed after twelve (12) months of use.
- b. Upon completion of the project the customer will notify the Meter Services office via the Hotline to request the removal of the fire hydrant meter and appurtenances. A work order will be generated

<b>CITY OF SAN DIEGO CALIFORNIA DEPARTMENT INSTRUCTIONS</b>	<b>NUMBER DI 55.27</b>	<b>DEPARTMENT Water Department</b>
<b>SUBJECT  FIRE HYDRANT METER PROGRAM (FORMERLY: CONSTRUCTION METER PROGRAM)</b>	<b>PAGE 7 OF 10</b>	<b>EFFECTIVE DATE  October 15, 2002</b>
	<b>SUPERSEDES DI 55.27</b>	<b>DATED April 21, 2000</b>

for removal of the meter.

- c. Meter Section staff will remove the meter and backflow prevention assembly and return it to the Meter Shop. Once returned to the Meter Shop the meter and backflow will be tested for accuracy and functionality.
- d. Meter Section Staff will contact and notify Customer Services of the final read and any charges resulting from damages to the meter and backflow or its appurtenance. These charges will be added on the customer's final bill and will be sent to the address of record. Any customer who has an outstanding balance will not receive additional meters.
- e. Outstanding balances due may be deducted from deposits and any balances refunded to the customer. Any outstanding balances will be turned over to the City Treasurer for collection. Outstanding balances may also be transferred to any other existing accounts.

5. **EXCEPTIONS**

- 5.1 Any request for exceptions to this policy shall be presented, in writing, to the Customer Support Deputy Director, or his/her designee for consideration.

6. **MOBILE METER**

- 6.1 Mobile meters will be allowed on a case by case basis. All mobile meters will be protected by an approved backflow assembly and the minimum requirement will be a Reduced Pressure Principal Assembly. The two types of Mobile Meters are vehicle mounted and floating meters. Each style of meters has separate guidelines that shall be followed for the customer to retain service and are described below:

- a) **Vehicle Mounted Meters:** Customer applies for and receives a City owned Fire Hydrant Meter from the Meter Shop. The customer mounts the meter on the vehicle and brings it to the Meter Shop for

<b>CITY OF SAN DIEGO CALIFORNIA DEPARTMENT INSTRUCTIONS</b>	<b>NUMBER DI 55.27</b>	<b>DEPARTMENT Water Department</b>
<b>SUBJECT  FIRE HYDRANT METER PROGRAM (FORMERLY: CONSTRUCTION METER PROGRAM)</b>	<b>PAGE 8 OF 10</b>	<b>EFFECTIVE DATE  October 15, 2002</b>
	<b>SUPERSEDES DI 55.27</b>	<b>DATED April 21, 2000</b>

inspection. After installation is approved by the Meter Shop the vehicle and meter shall be brought to the Meter Shop on a monthly basis for meter reading and on a quarterly basis for testing of the backflow assembly. Meters mounted at the owner's expense shall have the one year contract expiration waived and shall have meter or backflow changed if either fails.

b) **Floating Meters:** Floating Meters are meters that are not mounted to a vehicle. **(Note: All floating meters shall have an approved backflow assembly attached.)** The customer shall submit an application and a letter explaining the need for a floating meter to the Meter Shop. The Fire Hydrant Meter Administrator, after a thorough review of the needs of the customer, (i.e. number of jobsites per day, City contract work, lack of mounting area on work vehicle, etc.), may issue a floating meter. At the time of issue, it will be necessary for the customer to complete and sign the "Floating Fire Hydrant Meter Agreement" which states the following:

- 1) The meter will be brought to the Meter Shop at 2797 Caminito Chollas, San Diego on the third week of each month for the monthly read by Meter Shop personnel.
- 2) Every other month the meter will be read and the backflow will be tested. This date will be determined by the start date of the agreement.

If any of the conditions stated above are not met the Meter Shop has the right to cancel the contract for floating meter use and close the account associated with the meter. The Meter Shop will also exercise the right to refuse the issuance of another floating meter to the company in question.

Any Fire Hydrant Meter using reclaimed water shall not be allowed use again with any potable water supply. The customer shall incur the cost of replacing the meter and backflow device in this instance.

<b>CITY OF SAN DIEGO CALIFORNIA DEPARTMENT INSTRUCTIONS</b>	<b>NUMBER DI 55.27</b>	<b>DEPARTMENT Water Department</b>
<b>SUBJECT  FIRE HYDRANT METER PROGRAM (FORMERLY: CONSTRUCTION METER PROGRAM)</b>	<b>PAGE 9 OF 10</b>	<b>EFFECTIVE DATE  October 15, 2002</b>
	<b>SUPERSEDES DI 55.27</b>	<b>DATED April 21, 2000</b>

7. **FEE AND DEPOSIT SCHEDULES**

7.1 **Fees and Deposit Schedules:** The fees and deposits, as listed in the Rate Book of Fees and Charges, on file with the Office of the City Clerk, are based on actual reimbursement of costs of services performed, equipment and materials. These deposits and fees will be amended, as needed, based on actual costs. Deposits, will be refunded at the end of the use of the fire hydrant meter, upon return of equipment in good working condition and all outstanding balances on account are paid. Deposits can also be used to cover outstanding balances.

All fees for equipment, installation, testing, relocation and other costs related to this program are subject to change without prior notification. The Mayor and Council will be notified of any future changes.

8. **UNAUTHORIZED USE OF WATER FROM A HYDRANT**

8.1 Use of water from any fire hydrant without a properly issued and installed fire hydrant meter is theft of City property. Customers who use water for unauthorized purposes or without a City of San Diego issued meter will be prosecuted.

8.2 If any unauthorized connection, disconnection or relocation of a fire hydrant meter, or other connection device is made by anyone other than authorized Water Department personnel, the person making the connection will be prosecuted for a violation of San Diego Municipal Code, Section 67.15. In the case of a second offense, the customer's fire hydrant meter shall be confiscated and/or the deposit will be forfeited.

8.3 Unauthorized water use shall be billed to the responsible party. Water use charges shall be based on meter readings, or estimates when meter readings are not available.

8.4 In case of unauthorized water use, the customer shall be billed for all applicable charges as if proper authorization for the water use had been obtained, including but not limited to bi-monthly service charges, installation charges and removal charges.

<b>CITY OF SAN DIEGO CALIFORNIA DEPARTMENT INSTRUCTIONS</b>	<b>NUMBER DI 55.27</b>	<b>DEPARTMENT Water Department</b>
<b>SUBJECT  FIRE HYDRANT METER PROGRAM (FORMERLY: CONSTRUCTION METER PROGRAM)</b>	<b>PAGE 10 OF 10</b>	<b>EFFECTIVE DATE  October 15, 2002</b>
	<b>SUPERSEDES DI 55.27</b>	<b>DATED April 21, 2000</b>

- 8.5 If damage occurs to Water Department property (i.e. fire hydrant meter, backflow, various appurtenances), the cost of repairs or replacements will be charged to the customer of record (applicant).

**Water Department Director**

- Tabs: 1. Fire Hydrant Meter Application  
2. Construction & Maintenance Related Activities With No Return To Sewer  
3. Notice of Discontinuation of Service

**APPENDIX**

**Administering Division:** Customer Support Division

**Subject Index:** Construction Meters  
Fire Hydrant  
Fire Hydrant Meter Program  
Meters, Floating or Vehicle Mounted  
Mobile Meter  
Program, Fire Hydrant Meter

**Distribution:** DI Manual Holders



# Application for Fire Hydrant Meter (EXHIBIT A)

(For Office Use Only)

NS REQ	FAC#
DATE	BY

METER SHOP (619) 527-7449

## Meter Information

Application Date	Requested Install Date:
------------------	-------------------------

Fire Hydrant Location: (Attach Detailed Map//Thomas Bros. Map Location or Construction drawing.) <b>Zip:</b>	T.B.	G.B. (CITY USE)
Specific Use of Water:		
Any Return to Sewer or Storm Drain, if so, explain:		
Estimated Duration of Meter Use:		<input type="checkbox"/> Check Box if Reclaimed Water

## Company Information

Company Name:			
Mailing Address:			
City:	State:	Zip:	Phone: ( )
*Business license#		*Contractor license#	
A Copy of the Contractor's license OR Business License is required at the time of meter issuance.			
Name and Title of Billing Agent: <small>(PERSON IN ACCOUNTS PAYABLE)</small>			Phone: ( )
Site Contact Name and Title:			Phone: ( )
Responsible Party Name:			Title:
Cal ID#			Phone: ( )
Signature:		Date:	
<small>Guarantees Payment of all Charges Resulting from the use of this Meter. Insures that employees of this Organization understand the proper use of Fire Hydrant Meter</small>			

<b>Fire Hydrant Meter Removal Request</b>	Requested Removal Date:
Provide Current Meter Location if Different from Above:	
Signature:	Title:      Date:
Phone: ( )	Pager: ( )

<input type="checkbox"/> City Meter	<input type="checkbox"/> Private Meter	
Contract Acct #:	Deposit Amount: <b>\$ 936.00</b>	Fees Amount: <b>\$ 62.00</b>
Meter Serial #	Meter Size: <b>05</b>	Meter Make and Style: <b>6-7</b>
Backflow #	Backflow Size:	Backflow Make and Style:
Name:	Signature:	Date:

**WATER USES WITHOUT ANTICIPATED CHARGES FOR RETURN TO SEWER**

Auto Detailing  
Backfilling  
Combination Cleaners (Vactors)  
Compaction  
Concrete Cutters  
Construction Trailers  
Cross Connection Testing  
Dust Control  
Flushing Water Mains  
Hydro Blasting  
Hydro Seeing  
Irrigation (for establishing irrigation only; not continuing irrigation)  
Mixing Concrete  
Mobile Car Washing  
Special Events  
Street Sweeping  
Water Tanks  
Water Trucks  
Window Washing

**Note:**

1. If there is any return to sewer or storm drain, then sewer and/or storm drain fees will be charges.



Date

Name of Responsible Party  
Company Name and Address  
Account Number: \_\_\_\_\_

Subject:           Discontinuation of Fire Hydrant Meter Service

Dear Water Department Customer:

The authorization for use of Fire Hydrant Meter # \_\_\_\_\_, located at *(Meter Location Address)* ends in 60 days and will be removed on or after *(Date Authorization Expires)*. Extension requests for an additional 90 days must be submitted in writing for consideration 30 days prior to the discontinuation date. If you require an extension, please contact the Water Department, or mail your request for an extension to:

City of San Diego  
Water Department  
Attention: Meter Services  
2797 Caminito Chollas  
San Diego, CA 92105-5097

Should you have any questions regarding this matter, please call the Fire Hydrant Hotline at (619) \_\_\_\_\_ - \_\_\_\_\_.

Sincerely,

Water Department

## **APPENDIX C**

### **MATERIALS TYPICALLY ACCEPTED BY CERTIFICATE OF COMPLIANCE**

## **MATERIALS TYPICALLY ACCEPTED BY CERTIFICATE OF COMPLIANCE**

1. Soil amendment
2. Fiber mulch
3. PVC or PE pipe up to 16 inch diameter
4. Stabilizing emulsion
5. Lime
6. Preformed elastomeric joint seal
7. Plain and fabric reinforced elastomeric bearing pads
8. Steel reinforced elastomeric bearing pads
9. Waterstops (Special Condition)
10. Epoxy coated bar reinforcement
11. Plain and reinforcing steel
12. Structural steel
13. Structural timber and lumber
14. Treated timber and lumber
15. Lumber and timber
16. Aluminum pipe and aluminum pipe arch
17. Corrugated steel pipe and corrugated steel pipe arch
18. Structural metal plate pipe arches and pipe arches
19. Perforated steel pipe
20. Aluminum underdrain pipe
21. Aluminum or steel entrance tapers, pipe downdrains, reducers, coupling bands and slip joints
22. Metal target plates
23. Paint (traffic striping)
24. Conductors
25. Painting of electrical equipment
26. Electrical components
27. Engineering fabric
28. Portland Cement
29. PCC admixtures
30. Minor concrete, asphalt
31. Asphalt (oil)
32. Liquid asphalt emulsion
33. Epoxy

**APPENDIX D**

**SAMPLE CITY INVOICE WITH CASH FLOW FORECAST**



WBS #:	B18108
Date Submitted:	10/10/2018
NTP Date:	3/23/2018
Final Statement of WD Date:	5/23/2020
Contract #:	K-XX-XXXX-XXX-X
Contract Amount:	\$5,617,000

## Construction Cash Flow Forecast

"Sewer and Water Group Job 965 (W)"

Year	January	February	March	April	May	June	July	August	September	October	November	December
2018				15,000	25,000	52,000	52,000	100,000	10,000	100,000	100,000	100,000
2019	10,000	10,000	85,000	58,000	100,000	100,000	100,000	100,000	100,000	100,000	1,000,000	1,000,000
2020	100,000	100,000	100,000	1,000,000	1,000,000							
2021												
2022												
2023												
2024												
2025												

SAMPLE REFERENCE

**APPENDIX E**  
**LOCATION MAP**

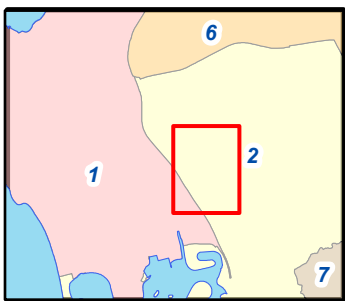

# Engineering & Capital Projects

## BAY HO IMPROV 2

SENIOR ENGINEER  
JAIME RAMOS  
(619) 533-5103

PROJECT MANAGER  
ROBERTO VALADEZ  
(619) 533-7422

PROJECT ENGINEER  
ISABEL BISHOP  
(619) 533-4181

FOR QUESTIONS ABOUT THIS PROJECT  
Call: (619) 533-4207  
Email: [engineering@san-diego.gov](mailto:engineering@san-diego.gov)

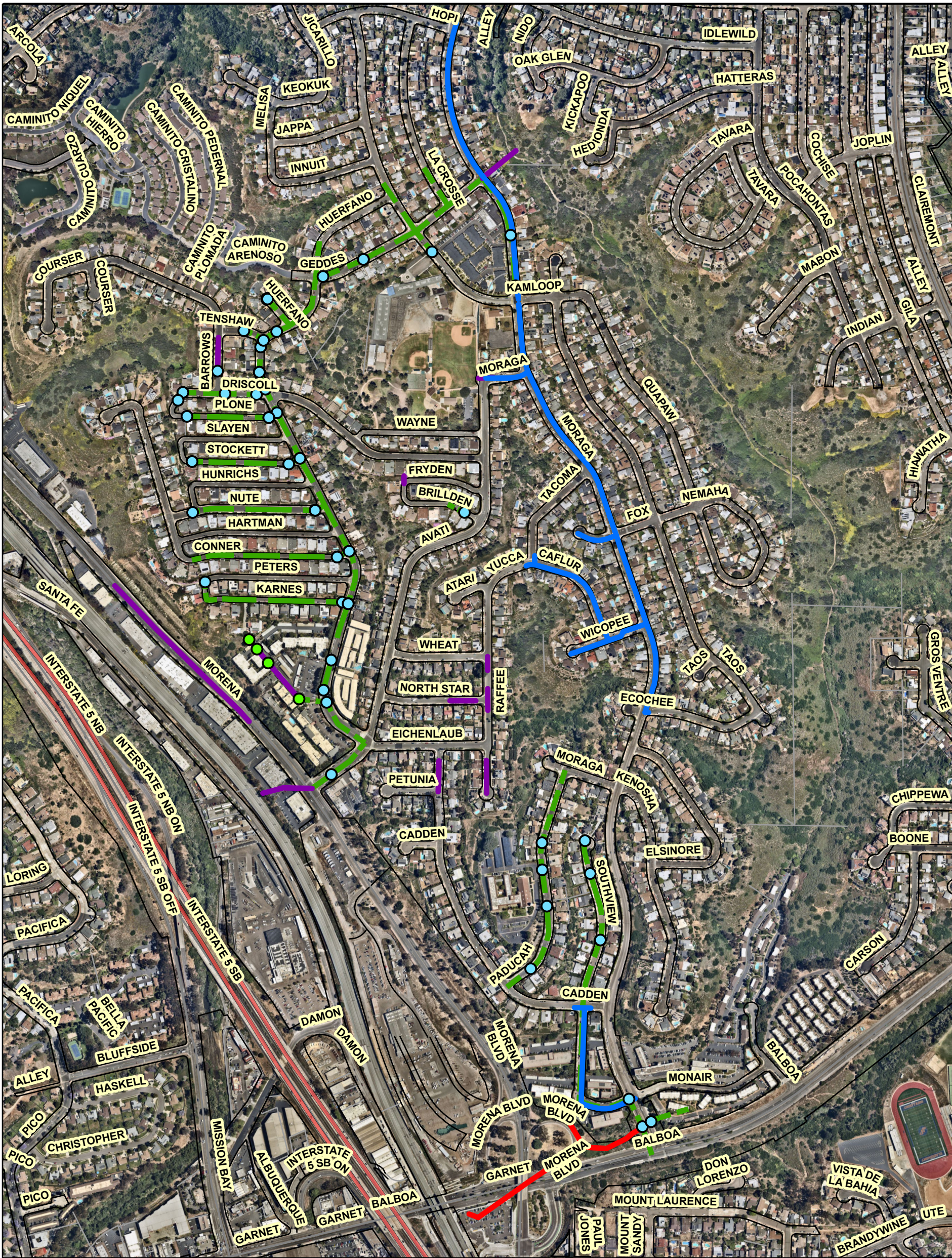

### Legend

- New Manhole
- Repair Manhole
- Proposed Water Main
- Proposed Sewer Main
- Sewer Main Rehabilitation
- Abandonment pipe

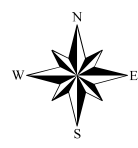

COMMUNITY NAME: Clairemont Mesa

COUNCIL DISTRICT: 2

Date: December 6, 2023  
K-24-2247-DBB-3  
Bay Ho Improv 2

WBS NO: B19104 (S)  
B19106 (W)



THIS MAP/DATA IS PROVIDED WITHOUT WARRANTY OF ANY KIND, EITHER EXPRESS OR IMPLIED, INCLUDING, BUT NOT LIMITED TO, THE IMPLIED WARRANTIES OR MERCHANTABILITY AND FITNESS FOR A PARTICULAR PURPOSE. Note: This product may contain information reproduced with permission granted by RAND McNALLY & COMPANY to SanGIS. This map is copyrighted by RAND McNALLY & COMPANY. It is unlawful to copy or reproduce all or any part thereof, whether for personal use or resale, without the prior, written permission of RAND McNALLY & COMPANY.



**APPENDIX F**  
**ADJACENT PROJECTS MAP**

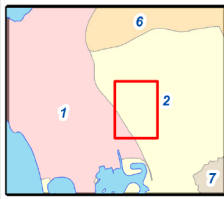

# Engineering & Capital Projects

## BAY HO IMPROV 2

SENIOR ENGINEER  
JAIME RAMOS  
(619) 533-5103

PROJECT MANAGER  
ROBERTO VALADEZ  
(619) 533-7422

PROJECT ENGINEER  
ISABEL BISHOP  
(619) 533-4181

FOR QUESTIONS ABOUT THIS PROJECT  
Call: (619) 533-4207  
Email: [engineering@sandiego.gov](mailto:engineering@sandiego.gov)

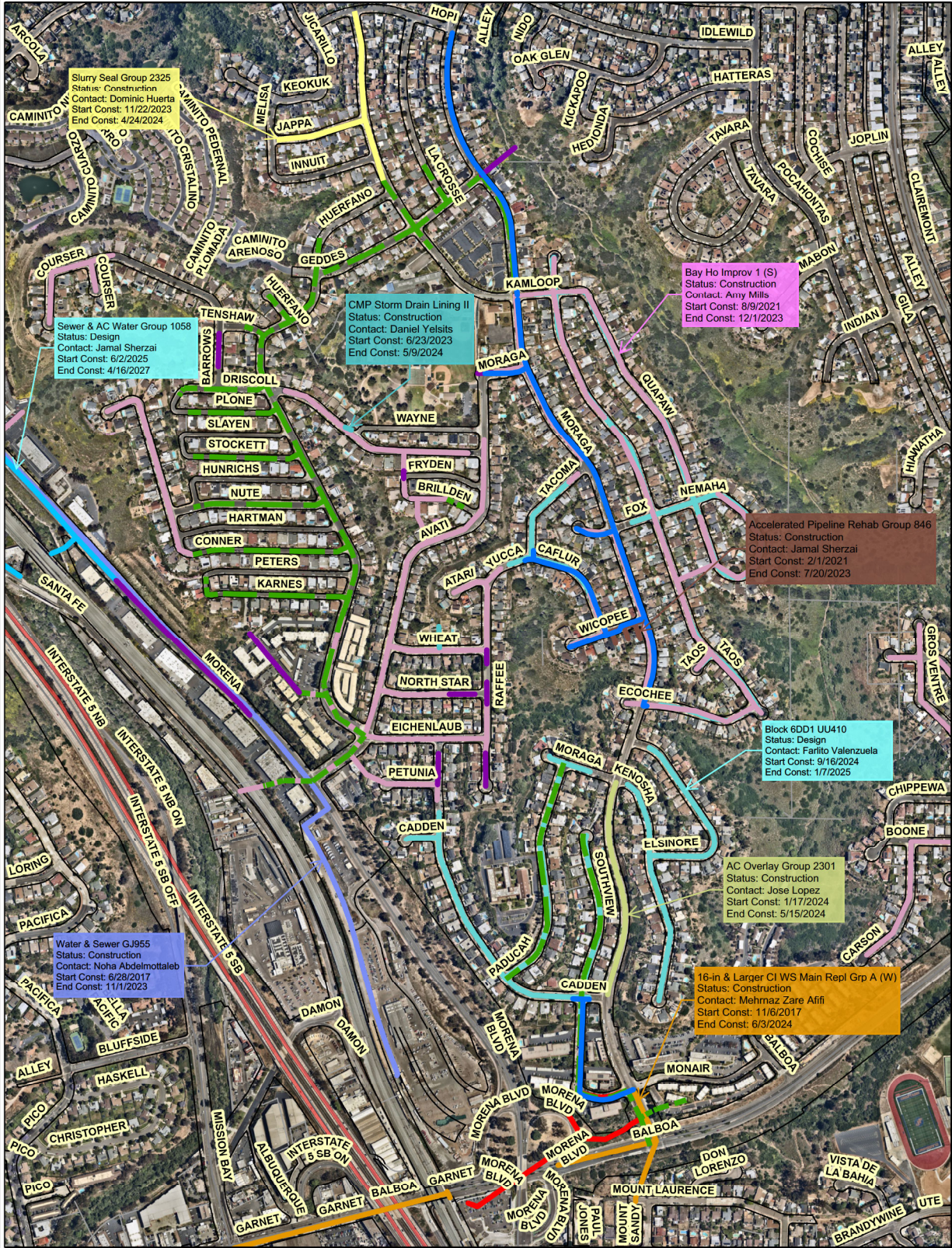

**Slurry Seal Group 2325**  
Status: Construction  
Contact: Dominic Huerta  
Start Const: 11/22/2023  
End Const: 4/24/2024

**Sewer & AC Water Group 1058**  
Status: Design  
Contact: Jamal Sherzai  
Start Const: 6/2/2025  
End Const: 4/16/2027

**CMP Storm Drain Lining II**  
Status: Construction  
Contact: Daniel Yelsits  
Start Const: 6/23/2023  
End Const: 5/9/2024

**Bay Ho Improv 1 (S)**  
Status: Construction  
Contact: Amy Mills  
Start Const: 8/9/2021  
End Const: 12/1/2023

**Accelerated Pipeline Rehab Group 846**  
Status: Construction  
Contact: Jamal Sherzai  
Start Const: 2/1/2021  
End Const: 7/20/2023

**Block 6DD1 UU410**  
Status: Design  
Contact: Farlito Valenzuela  
Start Const: 9/16/2024  
End Const: 1/7/2025

**AC Overlay Group 2301**  
Status: Construction  
Contact: Jose Lopez  
Start Const: 1/17/2024  
End Const: 5/15/2024

**Water & Sewer GJ955**  
Status: Construction  
Contact: Noha Abdeltotaleb  
Start Const: 6/28/2017  
End Const: 11/1/2023

**16-in & Larger CI WS Main Repl Grp A (W)**  
Status: Construction  
Contact: Mehmaz Zare Afifi  
Start Const: 11/6/2017  
End Const: 6/3/2024

Legend	
	Proposed Water Main
	Sewer Main Rehabilitation
	Proposed Sewer Main
	Abandonment pipe
	CIP Line
	CIP Number
	B15134
	B18142
	B18185
	B18191
	B19088
	B20086
	B23130
	B23186
	B23191
	SS-014884-PV1



THIS MAP/DRAWING IS PROVIDED BY THE CONTRACTOR OF ANY KIND, EITHER EXPRESS OR IMPLIED, INCLUDING, BUT NOT LIMITED TO, THE IMPLIED WARRANTIES OR MERCHANTABILITY OF THE CONTRACTOR. THE CONTRACTOR SHALL BE RESPONSIBLE FOR THE ACCURACY OF THE INFORMATION PROVIDED HEREON. THE CONTRACTOR'S LIABILITY FOR NEGLIGENCE OR OTHERWISE SHALL BE LIMITED TO THE CONTRACT VALUE. THIS DOCUMENT IS THE PROPERTY OF SANDIEGO ENGINEERING & CAPITAL PROJECTS. IT IS UNLAWFUL TO COPY OR REPRODUCE ALL OR ANY PART THEREOF, WITHOUT THE PRIOR WRITTEN PERMISSION OF RAND MCNALLY & COMPANY.

**APPENDIX G**

**CONTRACTOR'S DAILY QUALITY CONTROL INSPECTION REPORT**

**Appendix G**

City of San Diego  
Asphalt Concrete Overlay  
**Contractor's Daily Quality Control Inspection Report**

Project Title: \_\_\_\_\_ Date: \_\_\_\_\_

Locations: 1. \_\_\_\_\_  
2. \_\_\_\_\_  
3. \_\_\_\_\_

Asphalt Mix Specification: Attached Supplier: \_\_\_\_\_

Dig out Locations: 1. \_\_\_\_\_  
2. \_\_\_\_\_  
3. \_\_\_\_\_

Tack Coat Application Rate @ Locations:  
1. \_\_\_\_\_  
2. \_\_\_\_\_  
3. \_\_\_\_\_

Asphalt Temperature at Placement @ Locations:  
1. \_\_\_\_\_  
2. \_\_\_\_\_  
3. \_\_\_\_\_

Asphalt Depth @Locations:  
1. \_\_\_\_\_  
2. \_\_\_\_\_  
3. \_\_\_\_\_

Compaction Test Result @Locations:  
1. \_\_\_\_\_  
2. \_\_\_\_\_  
3. \_\_\_\_\_

Location and nature of defects:

1. \_\_\_\_\_
2. \_\_\_\_\_
3. \_\_\_\_\_

Remedial and Corrective Actions taken or proposed for Engineer's approval:

1. \_\_\_\_\_
2. \_\_\_\_\_
3. \_\_\_\_\_

Date's City Laboratory representative was present:

1. \_\_\_\_\_
2. \_\_\_\_\_
3. \_\_\_\_\_

Verified the following:

1. Proper Storage of Materials & Equipment
2. Proper Operation of Equipment
3. Adherence to Plans and Specs
4. Review of QC Tests
5. Safety Inspection

Initials:

- \_\_\_\_\_
- \_\_\_\_\_
- \_\_\_\_\_
- \_\_\_\_\_
- \_\_\_\_\_

Deviations from QCP \_\_\_\_\_ (see attached)

Quality Control Plan Administrator's Signature:

Date Signed:

\_\_\_\_\_

\_\_\_\_\_

**APPENDIX H**

**MONTHLY DRINKING WATER DISCHARGE MONITORING FORM**

# DRINKING WATER DISCHARGE MONITORING FORM

(Use for All Discharges to the Storm Drain)

All discharge activities related to this project comply with the State Water Resources Control Board ORDER WQ 2014-0194-DWQ, STATEWIDE GENERAL NPDES PERMIT FOR DRINKING WATER SYSTEMS DISCHARGES as referenced by ([http://www.waterboards.ca.gov/water\\_issues/programs/npdes/docs/drinkingwater/final\\_statewide\\_wqo2014\\_0194\\_dwq.pdf](http://www.waterboards.ca.gov/water_issues/programs/npdes/docs/drinkingwater/final_statewide_wqo2014_0194_dwq.pdf)), and as follows:

<b>Project Name:</b>				<b>WBS No.:</b>			<b>Watershed No.</b>					
<b>Qualified Person Conducting Tests:</b>				<b>signature</b>								
<b>BMPs MUST BE IN PLACE PRIOR TO ANY SCHEDULED DISCHARGE</b>												
By signing, I certify that all of the statements and conditions for drinking water discharge events are correct.												
Event #1												
Discharge Location <sup>1</sup>	Category <sup>2</sup> (Select one)	Notification <sup>3</sup> (Select all that apply)	BMPs in Place <sup>4</sup> (Select all that apply)	Volume <sup>5</sup> (gal)	Sampling <sup>6</sup> (take samples at 10 mins, 50-60 mins & last 10 mins)				Exceedence <sup>7</sup>			Notes Report exceedence to RE & complete page 2 of 2
					Measure	Unit	Time	Result	Limit	No	Yes	
<b>Inlet Location</b>  <b>Start</b>  <b>End</b>  <b>Date:</b> <b>Time:</b>  <b>Date:</b> <b>Time:</b>	<b>Superchlorinated</b> <small>(Chlorine added for disinfection)</small>	<b>TSW</b> <small>(All Categories)</small>	<b>Sweep flow path</b> <small>(gutter, street, etc.)</small>	<b>Total</b>	<b>Chlorine</b>	mg/L			0.1 mg/L= Exceedence			
	<b>Large Volume</b> <small>(≥ 325,850 gal)</small>	<b>PUD</b> <small>(All Categories)</small>	<b>Dechlorination</b> <small>(diffusers, chemicals, etc.)</small>							<b>Reused</b> <small>(if any)</small>	<b>Turbidity</b>	NTU
	<b>Well Dev/Rehab</b> <small>(Not Typical)</small>	<b>Water Board</b> <small>(Large Volume Only)</small>	<b>Inlet Protection</b>		<b>pH</b>	Unit			Range 6.5 to 8.5			
	<b>Small Volume/Other</b> <small>(No Sampling Required)</small>	<b>County</b> <small>(≥100,000 gal &amp; within ¼ mile of ocean/bay; or if enters the County's MS4)</small>	<b>Sediment Controls</b>									
Event #2												
Discharge Location <sup>1</sup>	Category <sup>2</sup> (Select one)	Notification <sup>3</sup> (Select all that apply)	BMPs in Place <sup>4</sup> (Select all that apply)	Volume <sup>5</sup> (gal)	Sampling <sup>6</sup> (take samples at 10 mins, 50-60 mins & last 10 mins)				Exceedence <sup>7</sup>			Notes Report exceedence to RE & complete page 2 of 2
					Measure	Unit	Time	Result	Limit	No	Yes	
<b>Inlet Location</b>  <b>Start</b>  <b>End</b>  <b>Date:</b> <b>Time:</b>  <b>Date:</b> <b>Time:</b>	<b>Superchlorinated</b> <small>(Chlorine added for disinfection)</small>	<b>TSW</b> <small>(All Categories)</small>	<b>Sweep flow path</b> <small>(gutter, street, etc.)</small>	<b>Total</b>	<b>Chlorine</b>	mg/L			0.1 mg/L= Exceedence			
	<b>Large Volume</b> <small>(≥ 325,850 gal)</small>	<b>PUD</b> <small>(All Categories)</small>	<b>Dechlorination</b> <small>(diffusers, chemicals, etc.)</small>							<b>Reused</b> <small>(if any)</small>	<b>Turbidity</b>	NTU
	<b>Well Dev/Rehab</b> <small>(Not Typical)</small>	<b>Water Board</b> <small>(Large Volume Only)</small>	<b>Inlet Protection</b>		<b>pH</b>	Unit			Range 6.5 to 8.5			
	<b>Small Volume/Other</b> <small>(No Sampling Required)</small>	<b>County</b> <small>(≥100,000 gal &amp; within ¼ mile of ocean/bay; or if enters the County's MS4)</small>	<b>Sediment Controls</b>									

**Submit completed Form to RE**

Instructional Notes found on the Page 2 of 2

## Receiving Water Monitoring

(Complete only if limits exceed on Page 1 of 2)

<b>Event #1</b>	
1) Go to the location where the discharge enters the receiving water.	
<input type="checkbox"/> Accessible <input type="checkbox"/> Unable to Determine <input type="checkbox"/> No Safe Access	
2) If accessible, take photos and complete the visual monitoring below. If unable to determine, stop here. If no safe access, stop here.	
3) Visual Monitoring: Is the discharge into the receiving water...	
...causing erosion	<input type="checkbox"/> Yes <input type="checkbox"/> No
...carrying floating or suspended matter	<input type="checkbox"/> Yes <input type="checkbox"/> No
...causing discoloration	<input type="checkbox"/> Yes <input type="checkbox"/> No
...causing and impact to the aquatic life present	<input type="checkbox"/> Yes <input type="checkbox"/> No
...observed with visible film	<input type="checkbox"/> Yes <input type="checkbox"/> No
...observed with an sheen or coating	<input type="checkbox"/> Yes <input type="checkbox"/> No
...causing potential nuisance conditions	<input type="checkbox"/> Yes <input type="checkbox"/> No
3) If all answers are NO, stop here.	
<b>4) If any answers are YES, Notify the RE immediately for further action</b>	

<b>Event #2</b>	
1) Go to the location where the discharge enters the receiving water.	
<input type="checkbox"/> Accessible <input type="checkbox"/> Unable to Determine <input type="checkbox"/> No Safe Access	
2) If accessible, take photos and complete the visual monitoring below. If unable to determine, stop here. If no safe access, stop here.	
3) Visual Monitoring: Is the discharge into the receiving water...	
...causing erosion	<input type="checkbox"/> Yes <input type="checkbox"/> No
...carrying floating or suspended matter	<input type="checkbox"/> Yes <input type="checkbox"/> No
...causing discoloration	<input type="checkbox"/> Yes <input type="checkbox"/> No
...causing and impact to the aquatic life present	<input type="checkbox"/> Yes <input type="checkbox"/> No
...observed with visible film	<input type="checkbox"/> Yes <input type="checkbox"/> No
...observed with an sheen or coating	<input type="checkbox"/> Yes <input type="checkbox"/> No
...causing potential nuisance conditions	<input type="checkbox"/> Yes <input type="checkbox"/> No
3) If all answers are NO, stop here.	
<b>4) If any answers are YES, Notify the RE immediately for further action</b>	

## Instructional Notes

- 1) Log the location of the inlet or discharge point. For example: Albatross St & 5th Av. Log the start date and time and the end date and time of the discharge.
- 2) Log the discharge category. "Superchlorinated" are discharges where additional chlorine is added in order to adequately disinfect and sanitize drinking water system facilities. This does NOT include potable water containing residual chlorine from the water treatment process. "Large Volume" discharges are greater than 325,850 gallons of total volume for one event. "Well Dev/Rehab" are discharges of potable ground water from a well. This is not typical. If none of these categories apply, then select "Small Volume/Other."
- 3) Notifications of the location, date, time, category, and estimated volume of discharge must be made to the contacts and per the requirements below:

Contact	When to Notify	Email
TSW	3 days prior to all discharges	<a href="mailto:SWPPP@SanDiego.gov">SWPPP@SanDiego.gov</a>
PUD	3 days prior to all discharges	<a href="mailto:CompReports@SanDiego.gov">CompReports@SanDiego.gov</a> <a href="mailto:Rdavenport@SanDiego.gov">Rdavenport@SanDiego.gov</a>
San Diego Water Board	3 days prior to Large Volume discharges	<a href="mailto:SanDiego@WaterBoards.ca.gov">SanDiego@WaterBoards.ca.gov</a> <a href="mailto:Ben.Neill@WaterBoards.ca.gov">Ben.Neill@WaterBoards.ca.gov</a>
County of San Diego	3 days prior if 100,000 gal and within 1/4 mile of ocean/bay	DEH: <a href="mailto:Joseph.Palmer@SDCounty.ca.gov">Joseph.Palmer@SDCounty.ca.gov</a> <a href="mailto:Dominique.Edwards@SDCounty.ca.gov">Dominique.Edwards@SDCounty.ca.gov</a>
	3 days prior if enter county MS4 or unincorporated County	WPP: <a href="mailto:Nicholas.DeValle@SDCounty.ca.gov">Nicholas.DeValle@SDCounty.ca.gov</a> <a href="mailto:LUEG.Watersheds@sdcounty.ca.gov">LUEG.Watersheds@sdcounty.ca.gov</a>

- 4) At a minimum, sweep gutters prior to starting discharge and use dechlorination BMPs. The contractor and RE must monitor and determine if BMPs need to be removed or modified. For example if inlet protection is causing flooding at a storm drain inlet, contractor may elect to remove BMPs. Document any modification to BMPs in the notes
- 5) Total volume must be logged for all discharges. If discharge water is reused for other purposes such as watering a golf course, log that volume under "Reused"
- 6) Sampling is required for categories per the following table:

Category	Measure	Sample Frequency
Superchlorinated	Chlorine, Turbidity, pH	first 10 min, 50-60 min, last 10 min
Large Volume	Chlorine Turbidity	first 10 min, 50-60 min, last 10 min
Well Dev/Rehab	Chlorine Turbidity	first 10 min, 50-60 min, last 10 min
Small Volume/Other	None required	N/A

- 7) Effluent limitations must be monitored not to exceed per the following table:

Measure	Method	Limit
Chlorine	Field Measure	0.10 mg/L-Cl
Turbidity	Visual Estimate	20 NTU for inland waters
		225 NTU for ocean 100 NTU for wells
pH	Field Measure	6.5 - 8.5



**APPENDIX I**  
**HAZARDOUS WASTE LABEL/FORMS**

# HAZARDOUS WASTE

STATE AND FEDERAL LAW PROHIBITS IMPROPER DISPOSAL  
IF FOUND, CONTACT THE NEAREST POLICE, OR PUBLIC SAFETY  
AUTHORITY, OR THE U.S. ENVIRONMENTAL PROTECTION AGENCY  
OR THE CALIFORNIA DEPARTMENT OF HEALTH SERVICES

GENERATOR NAME \_\_\_\_\_

ADDRESS \_\_\_\_\_ 24 HR. PHONE ( ) \_\_\_\_\_

CITY \_\_\_\_\_ STATE \_\_\_\_\_ ZIP \_\_\_\_\_

EPA ID NO. \_\_\_\_\_ MANIFEST DOCUMENT NO. \_\_\_\_\_

EPA WASTE NO. \_\_\_\_\_ CA WASTE NO. \_\_\_\_\_ ACCUMULATION START DATE \_\_\_\_\_ / \_\_\_\_ / \_\_\_\_

CONTENTS, COMPOSITION \_\_\_\_\_

PROPER DOT SHIPPING NAME \_\_\_\_\_

TECHNICAL NAME (S) \_\_\_\_\_

UN/NA NO. WITH PREFIX \_\_\_\_\_

PHYSICAL STATE    HAZARDOUS PROPERTIES     FLAMMABLE     TOXIC  
 SOLID     LIQUID     CORROSIVE     REACTIVE     OTHER \_\_\_\_\_

**HANDLE WITH CARE!**  
CONTAINS HAZARDOUS OR TOXIC WASTES

# INCIDENT/RELEASE ASSESSMENT FORM <sup>1</sup>

## If you have an emergency, Call 911

*Handlers of hazardous materials are required to report releases. The following is a tool to be used for assessing if a release is reportable. Additionally, a non-reportable release incident form is provided to document why a release is not reported (see back).*

### Questions for Incident Assessment:

	YES	NO
1. Was anyone killed or injured, or did they require medical care or admitted to a hospital for observation?	<input type="checkbox"/>	<input type="checkbox"/>
2. Did anyone, other than employees in the immediate area of the release, evacuate?	<input type="checkbox"/>	<input type="checkbox"/>
3. Did the release cause off-site damage to public or private property?	<input type="checkbox"/>	<input type="checkbox"/>
4. Is the release greater than or equal to a reportable quantity (RQ)?	<input type="checkbox"/>	<input type="checkbox"/>
5. Was there an uncontrolled or unpermitted release to the air?	<input type="checkbox"/>	<input type="checkbox"/>
6. Did an uncontrolled or unpermitted release escape secondary containment, or extend into any sewers, storm water conveyance systems, utility vaults and conduits, wetlands, waterways, public roads, or off site?	<input type="checkbox"/>	<input type="checkbox"/>
7. Will control, containment, decontamination, and/or clean up require the assistance of federal, state, county, or municipal response elements?	<input type="checkbox"/>	<input type="checkbox"/>
8. Was the release or threatened release involving an unknown material or contains an unknown hazardous constituent?	<input type="checkbox"/>	<input type="checkbox"/>
9. Is the incident a threatened release (a condition creating a substantial probability of harm that requires immediate action to prevent, reduce, or mitigate damages to persons, property, or the environment)?	<input type="checkbox"/>	<input type="checkbox"/>
10. Is there an increased potential for secondary effects including fire, explosion, line rupture, equipment failure, or other outcomes that may endanger or cause exposure to employees, the general public, or the environment?	<input type="checkbox"/>	<input type="checkbox"/>

If the answer is YES to any of the above questions – report the release to the California Office of Emergency Services at 800-852-7550 and the local CUPA daytime: (619) 338-2284, after hours: (858) 565-5255. Note: other state and federal agencies may require notification depending on the circumstances.

\*Call 911 in an emergency\*

If all answers are NO, complete a Non Reportable Release Incident Form (page 2 of 2) and keep readily available. Documenting why a “no” response was made to each question will serve useful in the event questions are asked in the future, and to justify not reporting to an outside regulatory agency.

If in doubt, report the release.

<sup>1</sup> This document is a guide for accessing when hazardous materials release reporting is required by Chapter 6.95 of the California Health and Safety Code. It does not replace good judgment, Chapter 6.95, or other state or federal release reporting requirements.

# NON REPORTABLE RELEASE INCIDENT FORM

## 1. RELEASE AND RESPONSE DESCRIPTION

Incident # \_\_\_\_\_

Date/Time Discovered	Date/Time Discharge	Discharge Stopped <input type="checkbox"/> Yes <input type="checkbox"/> No
Incident Date / Time:		
Incident Business / Site Name:		
Incident Address:		
Other Locators (Bldg, Room, Oil Field, Lease, Well #, GIS)		
Please describe the incident and indicate specific causes and area affected. Photos Attached?: <input type="checkbox"/> Yes <input type="checkbox"/> No		
Indicate actions to be taken to prevent similar releases from occurring in the future.		

## 2. ADMINISTRATIVE INFORMATION

Supervisor in charge at time of incident:	Phone:
Contact Person:	Phone:

## 3. CHEMICAL INFORMATION

Chemical	Quantity <input type="checkbox"/> GAL <input type="checkbox"/> LBS <input type="checkbox"/> FT <sup>3</sup>
Chemical	Quantity <input type="checkbox"/> GAL <input type="checkbox"/> LBS <input type="checkbox"/> FT <sup>3</sup>
Chemical	Quantity <input type="checkbox"/> GAL <input type="checkbox"/> LBS <input type="checkbox"/> FT <sup>3</sup>
Clean-Up Procedures & Timeline:	
Completed By:	Phone:
Print Name:	Title:

**EMERGENCY RELEASE FOLLOW - UP NOTICE REPORTING FORM**

<b>A</b>	BUSINESS NAME	FACILITY EMERGENCY CONTACT & PHONE NUMBER ( ) -	
<b>B</b>	INCIDENT DATE MO DAY YR	TIME OES NOTIFIED (use 24 hr time)	OES CONTROL NO.
<b>C</b>	INCIDENT ADDRESS LOCATION	CITY / COMMUNITY	COUNTY ZIP
<b>D</b>	CHEMICAL OR TRADE NAME (print or type)		CAS Number
<b>E</b>	CHECK IF CHEMICAL IS LISTED IN 40 CFR 355, APPENDIX A <input type="checkbox"/>	CHECK IF RELEASE REQUIRES NOTIFICATION UNDER 42 U.S.C. Section 9603 (a) <input type="checkbox"/>	
<b>F</b>	PHYSICAL STATE CONTAINED <input type="checkbox"/> SOLID <input type="checkbox"/> LIQUID <input type="checkbox"/> GAS	PHYSICAL STATE RELEASED <input type="checkbox"/> SOLID <input type="checkbox"/> LIQUID <input type="checkbox"/> GAS	QUANTITY RELEASED
<b>G</b>	ENVIRONMENTAL CONTAMINATION <input type="checkbox"/> AIR <input type="checkbox"/> WATER <input type="checkbox"/> GROUND <input type="checkbox"/> OTHER	TIME OF RELEASE	DURATION OF RELEASE — DAYS — HOURS — MINUTES
<b>H</b>	ACTIONS TAKEN		
<b>I</b>	KNOWN OR ANTICIPATED HEALTH EFFECTS (Use the comments section for addition information)		
<b>J</b>	<input type="checkbox"/> ACUTE OR IMMEDIATE (explain) _____ <input type="checkbox"/> CHRONIC OR DELAYED (explain) _____ <input type="checkbox"/> NOTKNOWN (explain) _____		
<b>K</b>	ADVICE REGARDING MEDICAL ATTENTION NECESSARY FOR EXPOSED INDIVIDUALS		
<b>L</b>	COMMENTS (INDICATE SECTION (A - G) AND ITEM WITH COMMENTS OR ADDITIONAL INFORMATION)		
<b>M</b>	CERTIFICATION: I certify under penalty of law that I have personally examined and I am familiar with the information submitted and believe the submitted information is true, accurate, and complete. REPORTING FACILITY REPRESENTATIVE (print or type) _____ SIGNATURE OF REPORTING FACILITY REPRESENTATIVE _____ DATE: _____		

## **EMERGENCY RELEASE FOLLOW-UP NOTICE REPORTING FORM INSTRUCTIONS**

### **GENERAL INFORMATION:**

Chapter 6.95 of Division 20 of the California Health and Safety Code requires that written emergency release follow-up notices prepared pursuant to 42 U.S.C. § 11004, be submitted using this reporting form. Non-permitted releases of reportable quantities of Extremely Hazardous Substances (listed in 40 CFR 355, appendix A) or of chemicals that require release reporting under section 103(a) of the Comprehensive Environmental Response, Compensation, and Liability Act of 1980 [42 U.S.C. § 9603(a)] must be reported on the form, as soon as practicable, but no later than 30 days, following a release. The written follow-up report is required in addition to the verbal notification.

### **BASIC INSTRUCTIONS:**

- The form, when filled out, reports follow-up information required by 42 U.S.C § 11004. Ensure that all information requested by the form is provided as completely as possible.
- If the incident involves reportable releases of more than one chemical, prepare one report form for each chemical released.
- If the incident involves a series of separate releases of chemical(s) at different times, the releases should be reported on separate reporting forms.

### **SPECIFIC INSTRUCTIONS:**

**Block A:** Enter the name of the business and the name and phone number of a contact person who can provide detailed facility information concerning the release.

**Block B:** Enter the date of the incident and the time that verbal notification was made to OES. The OES control number is provided to the caller by OES at the time verbal notification is made. Enter this control number in the space provided.

**Block C:** Provide information pertaining to the location where the release occurred. Include the street address, the city or community, the county and the zip code.

**Block D:** Provide information concerning the specific chemical that was released. Include the chemical or trade name and the Chemical Abstract Service (CAS) number. Check all categories that apply. Provide best available information on quantity, time and duration of the release.

**Block E:** Indicate all actions taken to respond to and contain the release as specified in 42 U.S.C. § 11004(c).

**Block F:** Check the categories that apply to the health effects that occurred or could result from the release. Provide an explanation or description of the effects in the space provided. Use Block H for additional comments/information if necessary to meet requirements specified in 42 U.S.C. § 11004(c).

**Block G:** Include information on the type of medical attention required for exposure to the chemical released. Indicate when and how this information was made available to individuals exposed and to medical personnel, if appropriate for the incident, as specified in 42 U.S.C. § 11004(c).

**Block H:** List any additional pertinent information.

**Block I:** Print or type the name of the facility representative submitting the report. Include the official signature and the date that the form was prepared.

### **MAIL THE COMPLETED REPORT TO:**

**State Emergency Response Commission (SERC)  
Attn: Section 304 Reports  
Hazardous Materials Unit  
3650 Schriever Avenue  
Mather, CA 95655**

**NOTE:** Authority cited: Sections 25503, 25503.1 and 25507.1, Health and Safety Code. Reference: Sections 25503(b)(4), 25503.1, 25507.1, 25518 and 25520, Health and Safety Code.

**APPENDIX J**

**REHABILITATION DATA COLLECTION - SAMPLE SEWER MAINS, LATERALS, AND  
MANHOLES DATA TEMPLATES**







### REHAB DATA COLLECTION – MANHOLES

MH FSN	REHAB DATE	LINING TYPE	LINING MATERIAL VENDOR	LINING SYSTEM	REHAB CONTRACTOR	RIM ELEVATION	INVERT ELEVATION	ACTUAL DEPTH (VF)	COMMENTS	ACCEPTANCE DATE
70536	3/28/2007	POLYURETHANE	ZEBRON	ZEBRON 386	ZEBRON CORPORATION	49.8	41.95	7	Leave this row as a sample.	3/28/2007

**APPENDIX K**  
**SAMPLE ARCHAEOLOGY INVOICE**

**(FOR ARCHAEOLOGY ONLY)**

**Company Name**

**Address, telephone, fax**

**Date:** Insert Date

**To:** Name of Resident Engineer  
City of San Diego  
Construction Management and  
Field Services Division  
9573 Chesapeake Drive  
San Diego, CA 92123-1304

**Project Name:** Insert Project Name

**SAP Number (WBS/IO/CC):** Insert SAP Number

**Drawing Number:** Insert Drawing Number

**Invoice period:** Insert Date to Insert Date

**Work Completed:** Bid item Number – Description of Bid Item – Quantity – Unit Price– Amount

**Detailed summary of work completed under this bid item:** Insert detailed description of Work related to Archaeology Monitoring Bid item. See Note 1 below.

Summary of charges:

Description of Services	Name	Start Date	End Date	Total Hours	Hourly Rate	Amount
Field Archaeologist	Joe Smith	8/29/2011	9/2/2011	40	\$84	\$3,360
Laboratory Assistant	Jane Doe	8/29/2011	9/2/2011	2	\$30	\$60
Subtotal						\$3,420

**Work Completed:** Bid item Number – Description of Bid Item – Quantity – Unit Price– Amount

**Detailed summary of work completed under this bid item:** Insert detailed description of Work related to Archaeology Curation/Discovery Bid item. See Note 2 below.

Summary of charges:

Description of Services	Where work occurred (onsite vs offsite/lab)	Name	Start Date	End Date	Total Hours	Hourly Rate	Amount
Field Archaeologist		Joe Smith	8/29/2011	9/2/2011	40	\$84	\$3,360
Laboratory Assistant		Jane Doe	8/29/2011	9/2/2011	2	\$30	\$60
Subtotal							\$3,420

**Total this invoice:** \$ \_\_\_\_\_

**Total invoiced to date:** \$ \_\_\_\_\_

Note 1:

For monitoring related bid items or work please include summary of construction work that was monitored from Station to Station, Native American monitors present, MMC coordination, status and nature of monitoring and if any discoveries were made.

Note 2:

For curation/discovery related bid items or work completed as part of a discovery and curation process, the PI must provide a response to the following questions along with the invoice:

1. Preliminary results of testing including tentative recommendations regarding eligibility for listing in the California Register of Historical Resources (California Register).
  - a. Please briefly describe your application (consideration) of all four California Register criteria.
  - b. If the resource is eligible under Criterion D, please define the important information that may be present.
  - c. Were specialized studies performed? How many personnel were required? How many Native American monitors were present?
  - d. What is the age of the resource?
  - e. Please define types of artifacts to be collected and curated, including quantity of boxes to be submitted to the San Diego Archaeological Center (SDAC). How many personnel were required? How many Native American monitors were present?
2. Preliminary results of data recovery and a definition of the size of the representative sample.
  - a. Were specialized studies performed? Please define types of artifacts to be collected and curated, including quantity of boxes to be submitted to the SDAC. How many personnel were required? How many Native American monitors were present?
3. What resources were discovered during monitoring?
4. What is the landform context and what is the integrity of the resources?
5. What additional studies are necessary?
6. Based on application of the California Register criteria, what is the significance of the resources?
  - a. If the resource is eligible for the California Register, can the resource be avoided by construction?
  - b. If not, what treatment (mitigation) measures are proposed? Please define data to be recovered (if necessary) and what material will be submitted to the SDAC for curation. Are any specialized studies proposed?

(After the first invoice, not all the above information needs to be re-stated, just revise as applicable).

**APPENDIX L**

**ADVANCED METERING INFRASTRUCTURE (AMI) DEVICE PROTECTION**

## Protecting AMI Devices in Meter Boxes and on Street Lights

The Public Utilities Department (PUD) has begun the installation of the Advanced Metering Infrastructure (AMI) technology as a new tool to enhance water meter reading accuracy and efficiency, customer service and billing, and to be used by individual accounts to better manage the efficient use of water. **All AMI devices shall be protected per Section 402-2, "Protection", of the 2021 Whitebook.**

AMI technology allows water meters to be read electronically rather than through direct visual inspection by PUD field staff. This will assist PUD staff and customers in managing unusual consumption patterns which could indicate leaks or meter tampering on a customer's property.

Three of the main components of an AMI system are the:

- A. Endpoints, see Photo 1:

**Photo 1**



B. AMI Antenna attached to Endpoint (antenna not always required), see Photo 2:



---

Network Devices, see Photo 3:

**Photo 3**





AMI endpoints transmit meter information to the AMI system and will soon be on the vast majority of meters in San Diego. These AMI devices provide interval consumption data to the PUD's Customer Support Division. If these devices are damaged or communication is interrupted, this Division will be alerted of the situation. The endpoints are installed in water meter boxes, coffins, and vaults adjacent to the meter. A separate flat round antenna may also be installed through the meter box lid. This antenna is connected to the endpoint via cable. The following proper installation shall be implemented when removing the lid to avoid damaging the antenna, cable, and/or endpoint. Photo 4 below demonstrates a diagram of the connection:

**Photo 4**



The AMI device ERT/Endpoint/Transmitter shall be positioned and installed as discussed in this Appendix. If the ERT/Endpoint/Transmitter is disturbed, it shall be re-installed and returned to its original installation with the end points pointed upwards as shown below in Photo 5.

**The PUD's code compliance staff will issue citations and invoices to you for any damaged AMI devices that are not re-installed as discussed in the Contract Document**

Photo 5 below shows a typical installation of an AMI endpoint on a water meter.

**Photo 5**

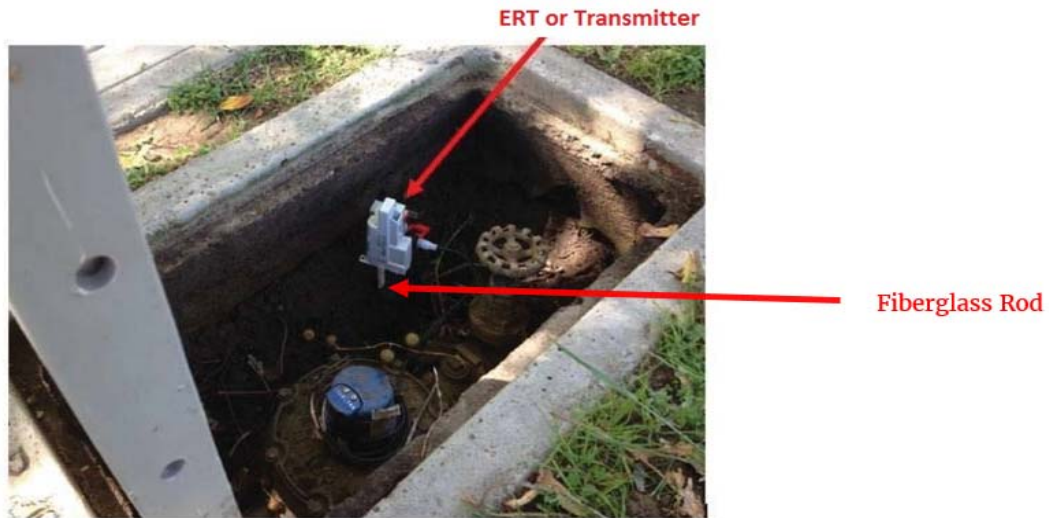

Photo 6 below is an example of disturbance that shall be avoided:

**Photo 6**



**You are responsible when working in and around meter boxes.** If you encounter these endpoints, use proper care and do not disconnect them from the registers on top of the water meter. If the lid has an antenna drilled through, do not change or tamper with the lid and inform the Resident Engineer immediately about the location of that lid. Refer to Photo 7 below:

**Photo 7**



Another component of the AMI system are the Network Devices. The Network Devices are strategically placed units (mainly on street light poles) that collect interval meter reading data from multiple meters for transmission to the Department Control Computer. **If you come across any of these devices on street lights that will be removed or replaced (refer to Photos 8 and 9 below), notify Elvira Santiesteban, Compliance & Metering Manager 619-380-3804 and Kevin Wilson, Senior Water Utility Supervisor 619-857-8257 immediately.**

Photo 8 shows an installed network device on a street light. On the back of each Network Device is a sticker with contact information. See Photo 9. **Call PUD Water Emergency Repairs at 619-515-3525 if your work will impact these street lights.** These are assets that belong to the City of San Diego and you shall be responsible for any costs of disruption of this network.

**Photo 8**



**Network Device**

**Photo 9**



**If you encounter any bad installations, disconnected/broken/buried endpoints, or inadvertently damage any AMI devices or cables, notify the Resident Engineer immediately. The Resident Engineer will then immediately contact Elvira Santiesteban, Compliance & Metering Manager 619-380-3804 and Kevin Wilson, Senior Water Utility Supervisor 619-857-8257.**

**APPENDIX M**  
**STANDARD DRAWINGS**

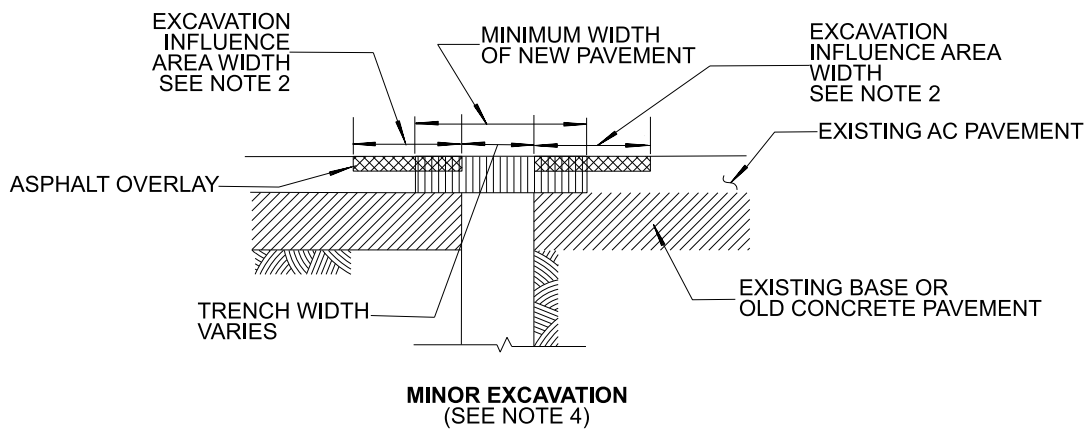
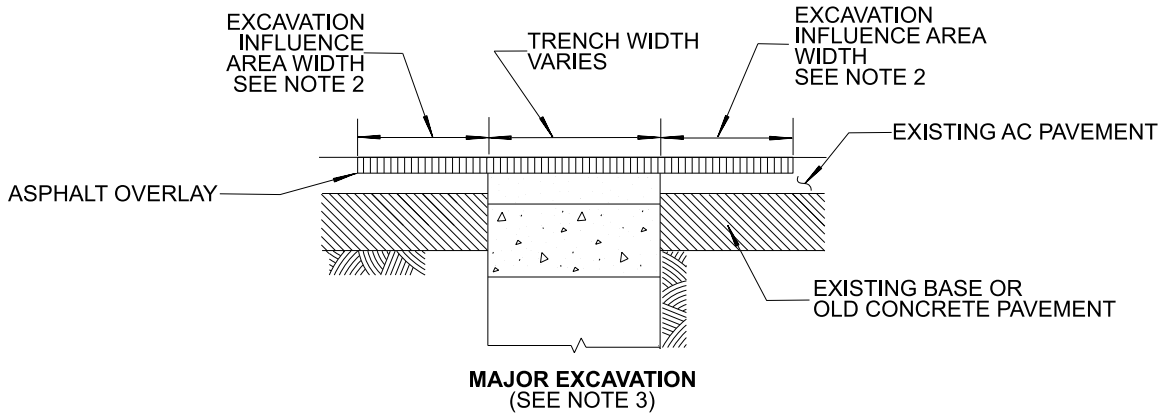

**NOTES:**

1. EXCAVATION INFLUENCE AREA MEANS THE AREA THAT IS IMPACTED BY THE EXCAVATION AS DETERMINED BY THE ENGINEER AND EXTENDS AROUND THE PERIMETER OF THE EXCAVATION AS SET FORTH IN THE TABLE 62-12A IN SECTION 62.1209 OF SAN DIEGO MUNICIPAL CODE.
2. THE EXCAVATION INFLUENCE AREA EXTENDS AROUND THE PERIMETER OF THE EXCAVATION AS SHOWN IN TABLE 1.

**TABLE 1. EXCAVATION INFLUENCE AREA WIDTH**

STREET CLASSIFICATION	WET UTILITIES	DRY UTILITIES
ARTERIAL STREETS	62 INCHES	51 INCHES
MAJOR STREETS	71 INCHES	55 INCHES
COLLECTOR STREETS	82 INCHES	43 INCHES
RESIDENTIAL STREETS	74 INCHES	46 INCHES

3. MAJOR EXCAVATION MEANS AN EXCAVATION INVOLVING A TRENCH GREATER THAN 6 INCHES IN WIDTH OR GREATER THAN 3 FEET IN DEPTH.
4. MINOR EXCAVATION MEANS AN EXCAVATION INVOLVING A TRENCH 6 INCHES OR LESS IN WIDTH AND 3 FEET OR LESS IN DEPTH.

SHEET 1 OF 2

REVISION	BY	APPROVED	DATE	CITY OF SAN DIEGO – STANDARD DRAWING	RECOMMENDED BY THE CITY OF SAN DIEGO STANDARDS COMMITTEE
ORIGINAL		R. AMEN	09/23		
				<b>PAVEMENT RESTORATION GENERAL NOTES</b>	<b>DRAFT</b>
					COORDINATOR R.C.E. 81047 DATE
					DRAWING NUMBER <b>SDG-105</b>

**NOTES (CONTINUED):**

5. ADDITIONAL REPAIRS FOR MAJOR EXCAVATIONS AND MINOR EXCAVATIONS (FOR WET AND DRY UTILITIES): THE PURPOSE OF THE ADDITIONAL PAVEMENT REPAIRS, INCLUDING BUT NOT LIMITED TO BASE AND SUB-BASE REPAIRS, DIG-OUTS, INLAYS, IS TO RESTORE THE SURFACE PAVEMENT TO ITS ORIGINAL CONDITION AND TO ENSURE PUBLIC SAFETY.
6. REPAIRS TO THE EXISTING PAVEMENT WITH OBSERVABLE FAILURES WITHIN THE EXCAVATION INFLUENCE AREA PER TABLE 1 SHALL BE PERFORMED AS DIRECTED BY THE ENGINEER. THE EXCAVATION INFLUENCE AREA IS MEASURED FROM THE OUTER EDGE OF THE TRENCH CUT EXCAVATION AND MUST BE RESURFACED REGARDLESS OF THE EXISTENCE OF OBSERVABLE FAILURE.
7. FOR ALTERNATIVE COMPLIANCE, PAVEMENT RESTORATION (MILL AND PAVE) MAY EXTEND TO THE FULL WIDTH OF OF THE IMPACTED TRAVEL LANE(S) WHERE THE STREET DAMAGE FEE WILL BE WAIVED. FOR UNMARKED TRAVEL LANES, THE CENTERLINE OF THE STREET OR INTERSECTION WILL BE CONSIDERED AS A REFERENCE FOR THE EXTENT OF THE LANE WIDTH TO CURB LINE OR POINT OF CURB RETURN (PCR).

SHEET 2 OF 2

REVISION	BY	APPROVED	DATE	CITY OF SAN DIEGO – STANDARD DRAWING	RECOMMENDED BY THE CITY OF SAN DIEGO STANDARDS COMMITTEE
ORIGINAL		R. AMEN	09/23		<b>DRAFT</b>
				<b>PAVEMENT RESTORATION GENERAL NOTES</b>	COORDINATOR R.C.E. 81047 DATE
					DRAWING NUMBER <b>SDG-105</b>

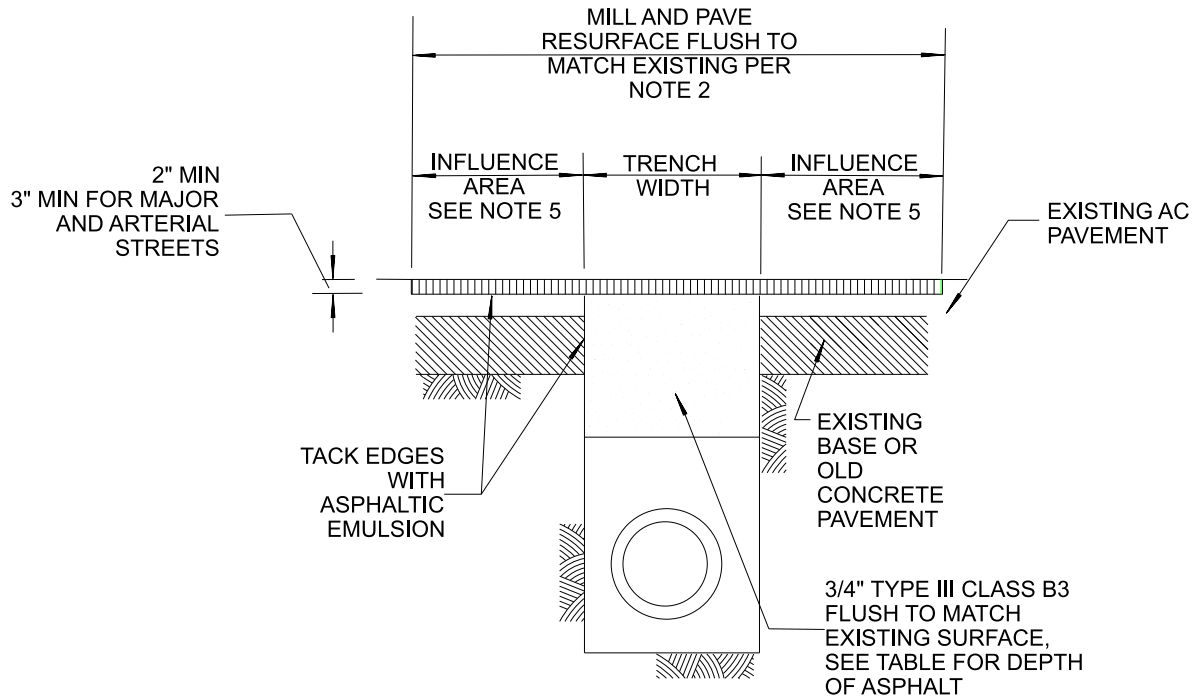

**TYPE 1**

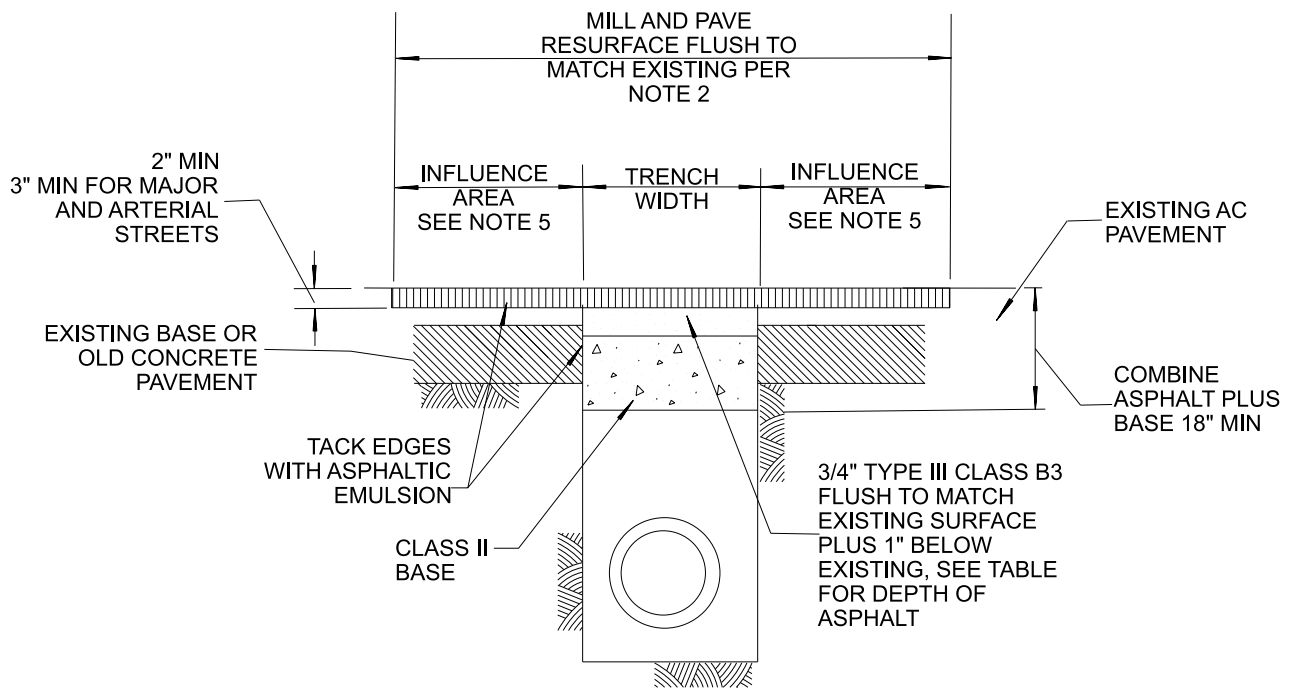

**TYPE 2**

SHEET 1 OF 2

REVISION	BY	APPROVED	DATE
ORIGINAL		J.P. CASEY	12489
UPDATED	KA	J. NAGELVOORT	4/13
UPDATED	BB	J. NAGELVOORT	1/14
UPDATED	LS	J. NAGELVOORT	02/16
UPDATED	JN	J. NAGELVOORT	11/17
REDRAFTED	CD	J. NAGELVOORT	09/18
UPDATED	ED	R. AMEN	09/23

CITY OF SAN DIEGO - STANDARD DRAWING

**PAVEMENT RESTORATION FOR  
ASPHALT CONCRETE SURFACED STREETS -  
MAJOR EXCAVATION**

RECOMMENDED BY THE CITY  
OF SAN DIEGO STANDARDS COMMITTEE

**DRAFT**

COORDINATOR R.C.E. 81047 DATE

---

DRAWING NUMBER **SDG-107**



**TABLE 1**

	TYPE 1	TYPE 2
	ASPHALT	ASPHALT PLUS BASE
MIX DESIGN	3/4" TYPE III CLASS B3	3/4" TYPE III CLASS B3 PLUS CLASS II BASE
ALLEYS	8.0"	ASPHALT THICKNESS TO EQUAL
LOCAL THROUGH 4 LANE COLLECTORS	10.0"	EXISTING PLUS 1", MIN 4" TO MAX. 9".
MAJOR	12.0"	COMBINED ASPHALT PLUS BASE 18" MIN.

**NOTES:**

1. ANY STREET TRENCH 7 FEET IN WIDTH OR GREATER AND LONGER THAN 100 FEET IN OVERALL LENGTH SHALL BE RECONSTRUCTED WITH THE PAVEMENT SECTION FOR THE STREET CLASSIFICATION PER SCHEDULE "J" (SDG-113).
2. IN STREETS NOT RECEIVING A FULL WIDTH OVERLAY PRIOR TO ACCEPTANCE, ASPHALT TRENCH CAPS SHALL BE MILLED AS SHOWN AND RESURFACED WITH 1/2" TYPE III CLASS C2 ASPHALT NO LESS THAN 30 CALENDAR DAYS AFTER INITIAL ASPHALT PLACEMENT.
3. IF THE STREET IS NOT SUBJECT TO CURB TO CURB ASPHALT OVERLAY, IT MUST COMPLETE FINAL STREET RESTORATION WITHIN 180 CALENDAR DAYS OF THE TRENCH CAP.
4. WHEN DIRECTED BY CITY ENGINEER OR SHOWN ON THE PLANS, CONCRETE PER SDG-108 (NOTE #5) MAY BE PLACED; A 1/8" - 1/4" WEARING SURFACING OF TYPE III CLASS F ASPHALT CONCRETE WILL BE REQUIRED.
5. ASPHALT OVERLAY THE ENTIRE LENGTH OF THE TRENCH INCLUDING THE INFLUENCE AREA AROUND THE PERIMETER OF THE EXCAVATION PER TABLE 1 IN SDG-105.
  - A. IF THE TRENCH OR EXCAVATION INFLUENCE AREA ENTERS A BICYCLE LANE, THE ENTIRE WIDTH OF THE BICYCLE SHALL BE ASPHALT OVERLAYED AND RESTRIPEDED FOR THE LENGTH OF THE TRENCH INCLUDING EXCAVATION INFLUENCE AREA. REPLACE IN KIND ANY EXISTING DELINEATORS.
6. EXCAVATOR SHALL ASPHALT OVERLAY IN MORATORIUM STREETS UNDER MORATORIUM DUE TO NEW CONSTRUCTION, RECONSTRUCTION, OR ASPHALT OVERLAY WITHIN 180 WORKING DAYS AFTER THE ENGINEER APPROVES THE TRENCH REPAIR.

SHEET 2 OF 2

REVISION	BY	APPROVED	DATE	CITY OF SAN DIEGO – STANDARD DRAWING	RECOMMENDED BY THE CITY OF SAN DIEGO STANDARDS COMMITTEE	
ORIGINAL		J.P. CASEY	12489			
UPDATED	KA	J. NAGELVOORT	4/13	<b>PAVEMENT RESTORATION FOR ASPHALT CONCRETE SURFACED STREETS - MAJOR EXCAVATION</b>	<b>DRAFT</b>	
UPDATED	BB	J. NAGELVOORT	1/14			COORDINATOR R.C.E. 81047 DATE
UPDATED	LS	J. NAGELVOORT	02/16		DRAWING	<b>SDG-107</b>
UPDATED	JN	J. NAGELVOORT	11/17		NUMBER	
REDRAFTED	CD	J. NAGELVOORT	09/18			
UPDATED	ED	R. AMEN	10/23			

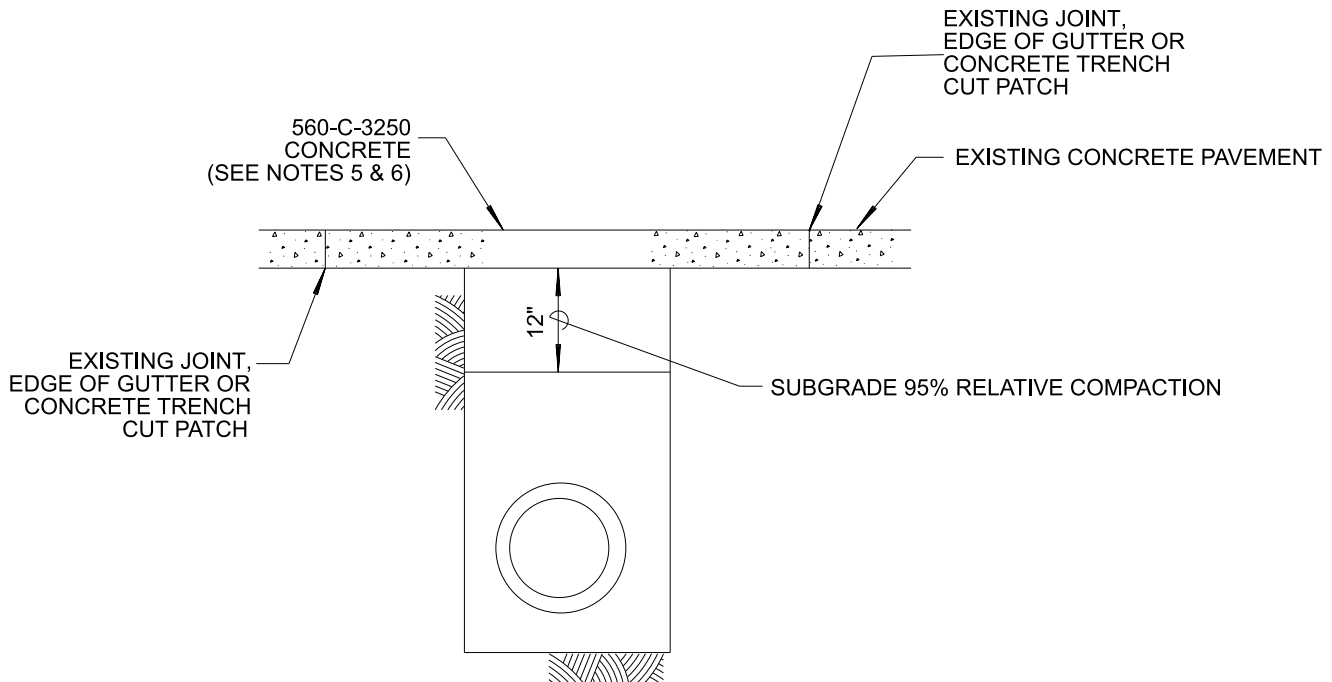

**NOTES:**

1. CONCRETE PAVEMENT RESTORATION SHALL EXTEND BEYOND THE EDGE OF THE TRENCH CUT TO THE NEAREST JOINT (FULL WIDTH OF CONCRETE PANEL, JOINT TO JOINT AROUND THE PERIMETER OF THE EXCAVATION) OR TO THE EDGE OF THE GUTTER. IF NO GUTTER IS PRESENT, EXTEND THE RESTORATION TO THE NEAREST CURB.
  - A. FOR CONCRETE PAVEMENT WITH EXISTING TRENCH CUT PATCHES THAT ARE 4'-0" OR LESS FROM THE EDGE OF THE EXCAVATION, CONCRETE PAVEMENT RESTORATION SHALL INCLUDE REMOVING THE EXISTING TRENCH CUT PATCHES AND REPLACING IT WITHIN THE NEW PCC CONSTRUCTION FOR THE NEW PANEL.
  - B. IF TRENCH CUT IS IN ALLEY APRON, CONCRETE RESTORATION SHALL BE TO THE NEAREST JOINT OR REPLACE ENTIRE ALLEY APRON IF NO JOINT. FOR NON-STANDARD ALLEY, INSTALL NEW CONCRETE PAVEMENT AS NEW JOINTS CAN BE INSTALLED TO THE EXTENTS OF THE RIGHT-OF-WAY.
2. PRIOR TO PLACING CONCRETE, PAVEMENT EDGES SHALL BE TRIMMED TO NEAT HORIZONTAL AND VERTICAL LINES.
3. UNLESS OTHERWISE SPECIFIED, CONCRETE TRENCH COVER SHALL BE A MINIMUM OF 5 1/2" FOR ALLEYS, 7" FOR LOCAL THROUGH FOUR LANE COLLECTOR STREETS AND 9" THICK FOR ALL MAJOR OR GREATER STREET CLASSIFICATIONS.
4. ANY STREET TRENCH 7'-0" IN WIDTH OR GREATER AND LONGER THAN 100'-0" IN LENGTH SHALL BE RECONSTRUCTED WITH THE PAVEMENT SECTION FOR THE STREET CLASSIFICATION **PER SCHEDULE "J" (SDG-113)**. STREET TRENCH SECTIONS 7'-0" IN WIDTH OR GREATER BUT LESS THAN 100'-0" IN OVERALL LENGTH SHALL BE RESURFACED TO A THICKNESS OF 1" GREATER THAN REQUIRED BY NOTE 3 ABOVE.
5. 560-C-3250 CONCRETE TREATED WITH A MINIMUM 2% CALCIUM CHLORIDE SOLUTION IN ACCORDANCE WITH 201-1 OR 650-CW-4000 (W/O CC) CONCRETE MAY BE OPENED TO TRAFFIC 3 DAYS AFTER IT IS PLACED. 650-CW-4000 CONCRETE TREATED IN SAME MANNER (W/CC) MAY BE OPENED TO TRAFFIC 24 HOURS AFTER IT IS PLACED. CONCRETE SPECIFIED BY ALTERNATE CLASS OR OTHERWISE CONTAINING FLY ASH IS NOT ALLOWED.
6. IN FOUR-LANE MAJOR OR GREATER STREETS, AN APPROVED SET ACCELERATING ADMIXTURE SUCH AS CALCIUM CHLORIDE, SHALL BE USED IN THE CONCRETE.
7. FINAL STREET RESTORATION SHALL BE COMPLETED WITHIN 180 CALENDAR DAYS AFTER COMPLETION OF THE TRENCH WORK WITHIN A STREET SEGMENT.

REVISION	BY	APPROVED	DATE	CITY OF SAN DIEGO – STANDARD DRAWING	RECOMMENDED BY THE CITY OF SAN DIEGO STANDARDS COMMITTEE	
ORIGINAL		J.CASEY	01/89		<b>PAVEMENT RESTORATION FOR CONCRETE SURFACED STREETS AND ALLEYS - MAJOR EXCAVATION</b>	<b>DRAFT</b>
UPDATED	KA	J. NAGELVOORT	01/12	COORDINATOR		R.C.E. 81047
UPDATED	BB	J. NAGELVOORT	01/14	DATE		
UPDATED	BB	J. NAGELVOORT	03/15	DRAWING		
REDRAFTED	CD	J. NAGELVOORT	09/18	NUMBER		<b>SDG-108</b>
UPDATED	FM	R. AMEN	09/23			

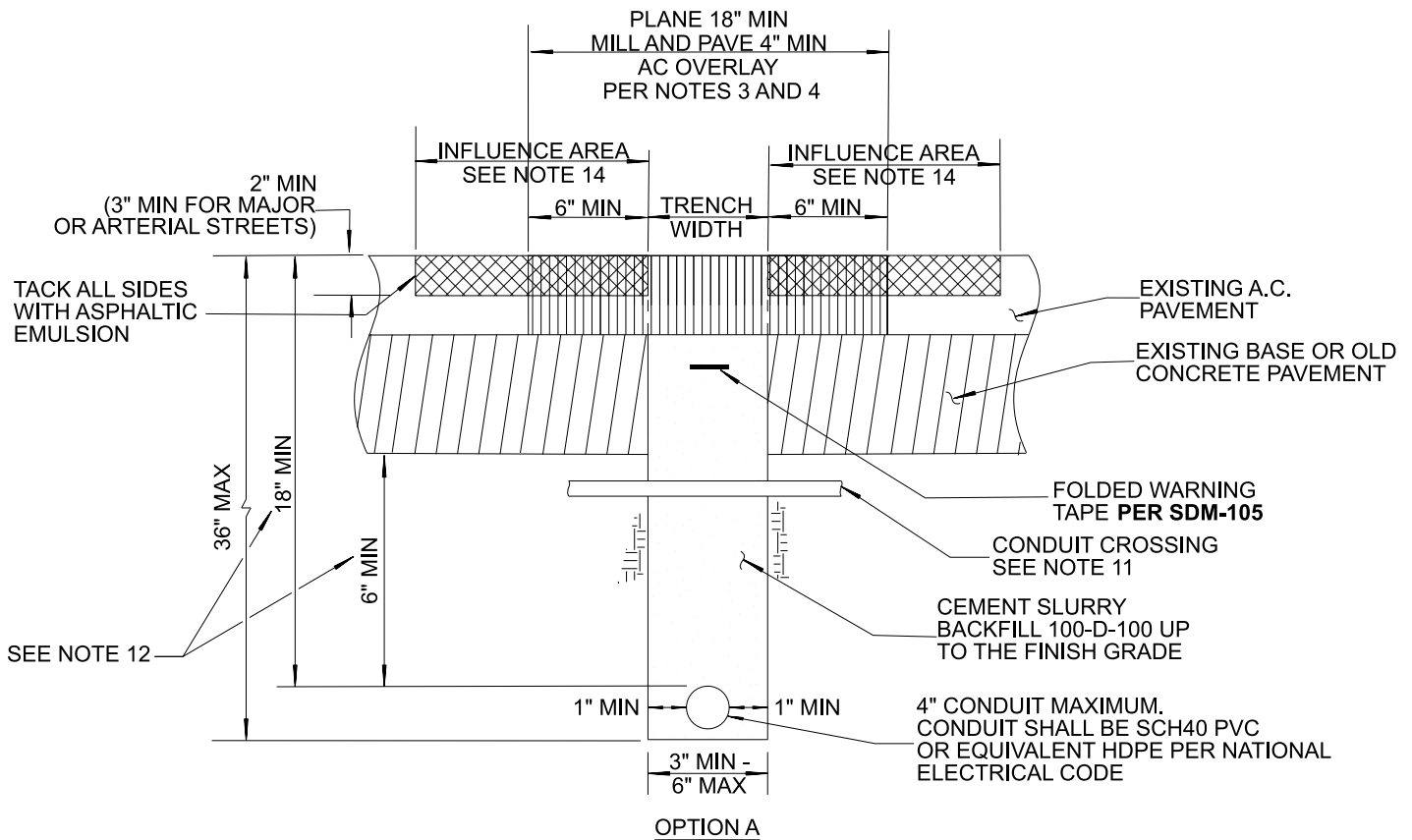

**NOTES (OPTION A):**

1. NEW TRENCH LOCATION SHALL BE 36 INCHES MINIMUM AND 72 INCHES MAXIMUM FROM LIP OF GUTTER, AND AT LEAST 36 INCHES CLEAR FROM ANY CITY UNDERGROUND FACILITIES.
  - A. THE CONTRACTOR SHALL CONTACT THE ENGINEER TO INSPECT AND APPROVE THE TRAFFIC CONTROL PLAN PRIOR TO START OF EXCAVATION IN A BICYCLE LANE. ENSURE ADEQUATE PROVISIONS HAVE BEEN INCLUDED FOR BICYCLE TRAFFIC INCLUDING BICYCLE DETOURS, IF APPLICABLE.
  - B. WHEN THE TRENCH AND/OR INFLUENCE AREA IS LOCATED WITHIN THE BICYCLE LANE, THE CONTRACTOR MUST PAVE THE FULL WIDTH OF THE BICYCLE LANE TO THE FACE OF CURB (I.E. GRIND AND OVERLAY) WITHIN SEVEN (7) CALENDAR DAYS OF AFTER THE INITIAL EXCAVATION. AT NO TIME SHALL A PARALLEL CUT OR SEAM EXIST IN THE BICYCLE LANE AS A FINAL RESTORATION.
  - C. THE CONTRACTOR SHALL PERFORM TRENCHING IN THE BICYCLE LANE IN ROAD SEGMENTS NOT TO EXCEED 500 LINEAR FEET PER SEGMENT. THE CONTRACTOR SHALL FULLY COMPLETE THE WORK ON EACH SEGMENT PRIOR TO STARTING THE NEXT SEGMENT.
2. CEMENT SLURRY BACKFILL SHALL BE THOROUGHLY CONSOLIDATED, HAVE A MAXIMUM SLUMP OF 4 INCHES. FLY ASH MEETING THE REQUIREMENTS OF 201-1.2.5.3 MAY BE ADDED (NOT AS A SUBSTITUTE) TO THE MINIMUM CEMENT REQUIREMENTS. SLURRY COMBINED GRADING SHALL MEET REQUIREMENTS OF 201-1.3.2 (A) GRADING D.
3. BALL DROP TEST PER ASTM D6024 SHALL BE PERFORMED ON SLURRY AND ACHIEVE A MAXIMUM INDENTATION DIAMETER OF 3 INCHES PRIOR TO PLACEMENT OF ASPHALT CONCRETE. SLURRY PLACED IN NARROW TRENCHES WHERE BALL DROP TEST CANNOT BE PERFORMED SHALL BE CURED A MINIMUM OF 48 HOURS PRIOR TO PLACEMENT OF ASPHALT CONCRETE. PERMANENT RESURFACING SHALL BE COMPLETED IN NO MORE THAN 7 DAYS AFTER PLACEMENT OF CEMENT SLURRY.

SEE ADDITIONAL NOTES ON SHEET 2

SHEET 1 OF 6

REVISION	BY	APPROVED	DATE	CITY OF SAN DIEGO - STANDARD DRAWING		RECOMMENDED BY THE CITY OF SAN DIEGO STANDARDS COMMITTEE		
ORIGINAL		BAHMANIAN	04/86	<b>PAVEMENT RESTORATION FOR ASPHALT CONCRETE SURFACED STREETS - MINOR EXCAVATION</b> <b>OPTION A - ONE CONDUIT</b>		<b>DRAFT</b>		
UPDATED	AA	J. NAGELVOORT	02/16			COORDINATOR	R.C.E. 81047	DATE
UPDATED	LS	M. GIBSON	05/17			<b>SDG-117A</b>		
REDRAFTED	CD	J. NAGELVOORT	09/18					
UPDATED	LS	J. NAGELVOORT	04/21					
UPDATED	RC	R. AMEN	10/23					

**NOTES (CONTINUED FOR OPTION A):**

4. DURING PLACEMENT, CONCAVE SLURRY SURFACE WITH A SHOVEL TO 1/2 INCH - 1 INCH DEPTH.
5. MINIMUM SPECIFIED SEPARATIONS MUST BE MAINTAINED UNTIL SLURRY HAS FULLY CURED. IT IS THE RESPONSIBILITY OF THE CONTRACTOR TO ENSURE THE CONDUIT DOES NOT SHIFT HORIZONTALLY OR FLOAT VERTICALLY IN THE TRENCH DURING THE APPLICATION OF THE SLURRY. SPOT POUR ONE SACK SLURRY OVER CONDUIT AT 25 FOOT INTERVALS TO PREVENT CONDUIT FROM FLOATING.
6. CUTS SHALL BE STRAIGHT. EXISTING A.C. PAVEMENT WILL NOT REQUIRE SAW CUTTING WHEN USING ROCKWHEEL FOR EXCAVATION PROVIDED THAT A SMOOTH SURFACE IS PRODUCED.
7. TRENCH SHALL BE MILLED TO A DEPTH OF 4 INCHES A MINIMUM OF 18 INCHES WIDE OR 12 INCHES WIDER THAN TRENCH WIDTH, WHICHEVER IS GREATER, AND RESURFACED WITH 1/2 INCH TYPE III CLASS C2 ASPHALT.
8. WHEN PCC TRENCH RESURFACING IS DIRECTED BY CITY ENGINEER, SHOWN ON THE PLANS, OR REQUIRED FOR A PCC SURFACED STREET, FOR ASPHALT STREETS SEE SDG-107 (NOTE #3) AND FOR CONCRETE SURFACED STREETS SEE SDG-108.
9. SDG-117A SHALL BE USED FOR THE PLACEMENT OF ONE CONDUIT. FOR THE PLACEMENT OF TWO CONDUITS USE SDG-117B AND FOR PLACEMENT OF THREE OR MORE CONDUITS USE SDG-117C OR SDG-119.
10. ALLOW THREE HOURS MINIMUM FOR ONE SACK SLURRY TRENCH BACKFILL CURE TIME FOR TRENCHES PARALLEL TO THE STREET BEFORE OPENING TO TRAFFIC.
11. SLEEVE EXISTING CONDUITS AT CROSSING.
12. TOP OF CONDUIT SHALL BE 18 INCHES MINIMUM FROM TOP OF PAVEMENT OR 6 INCHES MINIMUM FROM BOTTOM OF PAVEMENT SECTION, WHICHEVER IS GREATER.
13. CLEARANCE SEPARATIONS BETWEEN DRY AND WET UTILITIES PER CALIFORNIA PUBLIC UTILITY CODE GENERAL ORDER 128 SHALL BE MAINTAINED.
14. ASPHALT OVERLAY THE ENTIRE LENGTH OF THE TRENCH INCLUDING THE INFLUENCE AREA AROUND THE PERIMETER OF THE EXCAVATION PER TABLE 1 IN SDG-105.
  - A. IF THE TRENCH OR EXCAVATION INFLUENCE AREA ENTERS A BICYCLE LANE, THE ENTIRE WIDTH OF THE BICYCLE SHALL BE ASPHALT OVERLAYED AND RESTRIPEDED FOR THE LENGTH OF THE TRENCH INCLUDING EXCAVATION INFLUENCE AREA. REPLACE IN KIND ANY EXISTING DELINEATORS.

SHEET 2 OF 6

REVISION	BY	APPROVED	DATE	CITY OF SAN DIEGO – STANDARD DRAWING  <b>PAVEMENT RESTORATION FOR ASPHALT CONCRETE SURFACED STREETS - MINOR EXCAVATION OPTION A - ONE CONDUIT</b>	RECOMMENDED BY THE CITY OF SAN DIEGO STANDARDS COMMITTEE
ORIGINAL		BAHMANIAN	04/86		<b>DRAFT</b>
UPDATED	AA	J. NAGELVOORT	02/16		COORDINATOR R.C.E. 81047 DATE
UPDATED	LS	M. GIBSON	05/17		<b>SDG-117A</b>
REDRAFTED	CD	J. NAGELVOORT	09/18		
UPDATED	LS	J. NAGELVOORT	04/21		
UPDATED	RC	R. AMEN	10/23		

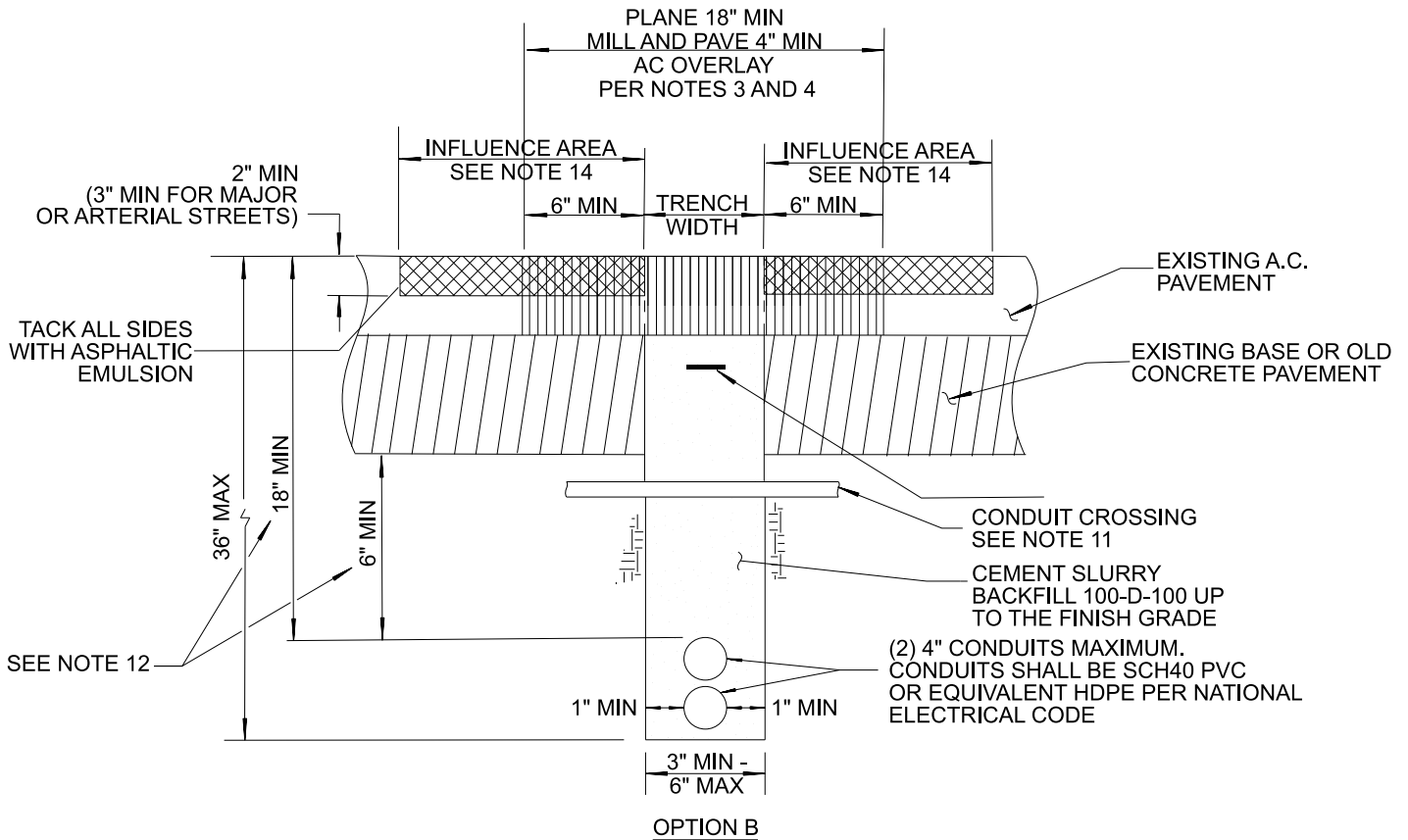

**NOTES (OPTION B):**

1. NEW TRENCH LOCATION SHALL BE 36 INCHES MINIMUM AND 72 INCHES MAXIMUM FROM LIP OF GUTTER, AND AT LEAST 36 INCHES CLEAR FROM ANY CITY UNDERGROUND FACILITIES.
  - A. THE CONTRACTOR SHALL CONTACT THE ENGINEER TO INSPECT AND APPROVE THE TRAFFIC CONTROL PLAN PRIOR TO START OF EXCAVATION IN A BICYCLE LANE. ENSURE ADEQUATE PROVISIONS HAVE BEEN INCLUDED FOR BICYCLE TRAFFIC INCLUDING BICYCLE DETOURS, IF APPLICABLE.
  - B. WHEN THE TRENCH AND/OR INFLUENCE AREA IS LOCATED WITHIN THE BICYCLE LANE, THE CONTRACTOR MUST PAVE THE FULL WIDTH OF THE BICYCLE LANE TO THE FACE OF CURB (I.E. GRIND AND OVERLAY) WITHIN SEVEN (7) CALENDAR DAYS OF AFTER THE INITIAL EXCAVATION. AT NO TIME SHALL A PARALLEL CUT OR SEAM EXIST IN THE BICYCLE LANE AS A FINAL RESTORATION.
  - C. THE CONTRACTOR SHALL PERFORM TRENCHING IN THE BICYCLE LANE IN ROAD SEGMENTS NOT TO EXCEED 500 LINEAR FEET PER SEGMENT. THE CONTRACTOR SHALL FULLY COMPLETE THE WORK ON EACH SEGMENT PRIOR TO STARTING THE NEXT SEGMENT.
2. CEMENT SLURRY BACKFILL SHALL BE THOROUGHLY CONSOLIDATED, HAVE A MAXIMUM SLUMP OF 4 INCHES. FLY ASH MEETING THE REQUIREMENTS OF 201-1.2.5.3 MAY BE ADDED (NOT AS A SUBSTITUTE) TO THE MINIMUM CEMENT REQUIREMENTS. SLURRY COMBINED GRADING SHALL MEET REQUIREMENTS OF 201-1.3.2 (A) GRADING D.
3. BALL DROP TEST PER ASTM D6024 SHALL BE PERFORMED ON SLURRY AND ACHIEVE A MAXIMUM INDENTATION DIAMETER OF 3 INCHES PRIOR TO PLACEMENT OF ASPHALT CONCRETE. SLURRY PLACED IN NARROW TRENCHES WHERE BALL DROP TEST CANNOT BE PERFORMED SHALL BE CURED A MINIMUM OF 48 HOURS PRIOR TO PLACEMENT OF ASPHALT CONCRETE. PERMANENT RESURFACING SHALL BE COMPLETED IN NO MORE THAN 7 DAYS AFTER PLACEMENT OF CEMENT SLURRY.

SEE ADDITIONAL NOTES ON SHEET 4

SHEET 3 OF 6

REVISION	BY	APPROVED	DATE	CITY OF SAN DIEGO - STANDARD DRAWING	RECOMMENDED BY THE CITY OF SAN DIEGO STANDARDS COMMITTEE
ORIGINAL		BAHMANIAN	04/86		
UPDATED	AA	J. NAGELVOORT	02/16		
UPDATED	LS	M. GIBSON	05/17		
REDRAFTED	CD	J. NAGELVOORT	09/18		
UPDATED	LS	J. NAGELVOORT	04/21		
UPDATED	RC	R. AMEN	10/23		
				DRAWING NUMBER	<b>SDG-117B</b>

**NOTES (CONTINUED FOR OPTION B):**

4. DURING PLACEMENT, CONCAVE SLURRY SURFACE WITH A SHOVEL TO 1/2 INCH - 1 INCH DEPTH.
5. MINIMUM SPECIFIED SEPARATIONS MUST BE MAINTAINED UNTIL SLURRY HAS FULLY CURED. IT IS THE RESPONSIBILITY OF THE CONTRACTOR TO ENSURE THE CONDUIT DOES NOT SHIFT HORIZONTALLY OR FLOAT VERTICALLY IN THE TRENCH DURING THE APPLICATION OF THE SLURRY. SPOT POUR ONE SACK SLURRY OVER CONDUIT AT 25 FOOT INTERVALS TO PREVENT CONDUIT FROM FLOATING.
6. CUTS SHALL BE STRAIGHT. EXISTING A.C. PAVEMENT WILL NOT REQUIRE SAW CUTTING WHEN USING ROCKWHEEL FOR EXCAVATION PROVIDED THAT A SMOOTH SURFACE IS PRODUCED.
7. TRENCH SHALL BE MILLED TO A DEPTH OF 4 INCHES AND A MINIMUM OF 18 INCHES WIDE OR 12 INCHES WIDER THAN TRENCH WIDTH, WHICHEVER IS GREATER, AND RESURFACED WITH 1/2 INCH TYPE III CLASS C2 ASPHALT.
8. WHEN PCC PAVEMENT RESTORATION IS DIRECTED BY CITY ENGINEER, SHOWN ON THE PLANS, OR REQUIRED FOR A PCC SURFACED STREET, FOR ASPHALT STREETS SEE SDG-107 (NOTE #3) AND FOR CONCRETE SURFACED STREETS SEE SDG-108.
9. SDG-117A SHALL BE USED FOR THE PLACEMENT OF ONE CONDUIT. FOR THE PLACEMENT OF TWO CONDUITS USE SDG-117B AND FOR PLACEMENT OF THREE OR MORE CONDUITS USE SDG-117C OR SDG-119.
10. ALLOW THREE HOURS MINIMUM FOR ONE SACK SLURRY TRENCH BACKFILL CURE TIME FOR TRENCHES PARALLEL TO THE STREET BEFORE OPENING TO TRAFFIC.
11. SLEEVE EXISTING CONDUITS AT CROSSING.
12. TOP OF CONDUIT SHALL BE 18 INCHES MINIMUM FROM TOP OF PAVEMENT OR 6 INCHES MINIMUM FROM BOTTOM OF PAVEMENT SECTION, WHICHEVER IS GREATER.
13. CLEARANCE SEPARATIONS BETWEEN DRY AND WET UTILITIES PER CALIFORNIA PUBLIC UTILITY CODE GENERAL ORDER 128 SHALL BE MAINTAINED.
14. ASPHALT OVERLAY THE ENTIRE LENGTH OF THE TRENCH INCLUDING THE INFLUENCE AREA AROUND THE PERIMETER OF THE EXCAVATION PER TABLE 1 IN SDG-105.
  - A. IF THE TRENCH OR EXCAVATION INFLUENCE AREA ENTERS A BICYCLE LANE, THE ENTIRE WIDTH OF THE BICYCLE SHALL BE ASPHALT OVERLAYED AND RESTRIPEDED FOR THE LENGTH OF THE TRENCH INCLUDING EXCAVATION INFLUENCE AREA. REPLACE IN KIND ANY EXISTING DELINEATORS.

SHEET 4 OF 6

REVISION	BY	APPROVED	DATE	CITY OF SAN DIEGO – STANDARD DRAWING  <b>PAVEMENT RESTORATION FOR ASPHALT CONCRETE SURFACE STREETS - MINOR EXCAVATION OPTION B - TWO CONDUITS</b>	RECOMMENDED BY THE CITY OF SAN DIEGO STANDARDS COMMITTEE
ORIGINAL		BAHMANIAN	0486		<b>DRAFT</b>
UPDATED	AA	J. NAGELVOORT	02/16		COORDINATOR R.C.E. 81047 DATE
UPDATED	LS	M. GIBSON	05/17		<b>SDG-117B</b>
REDRAFTED	CD	J. NAGELVOORT	09/18		
UPDATED	LS	J. NAGELVOORT	04/21		
UPDATED	RC	R. AMEN	10/23		

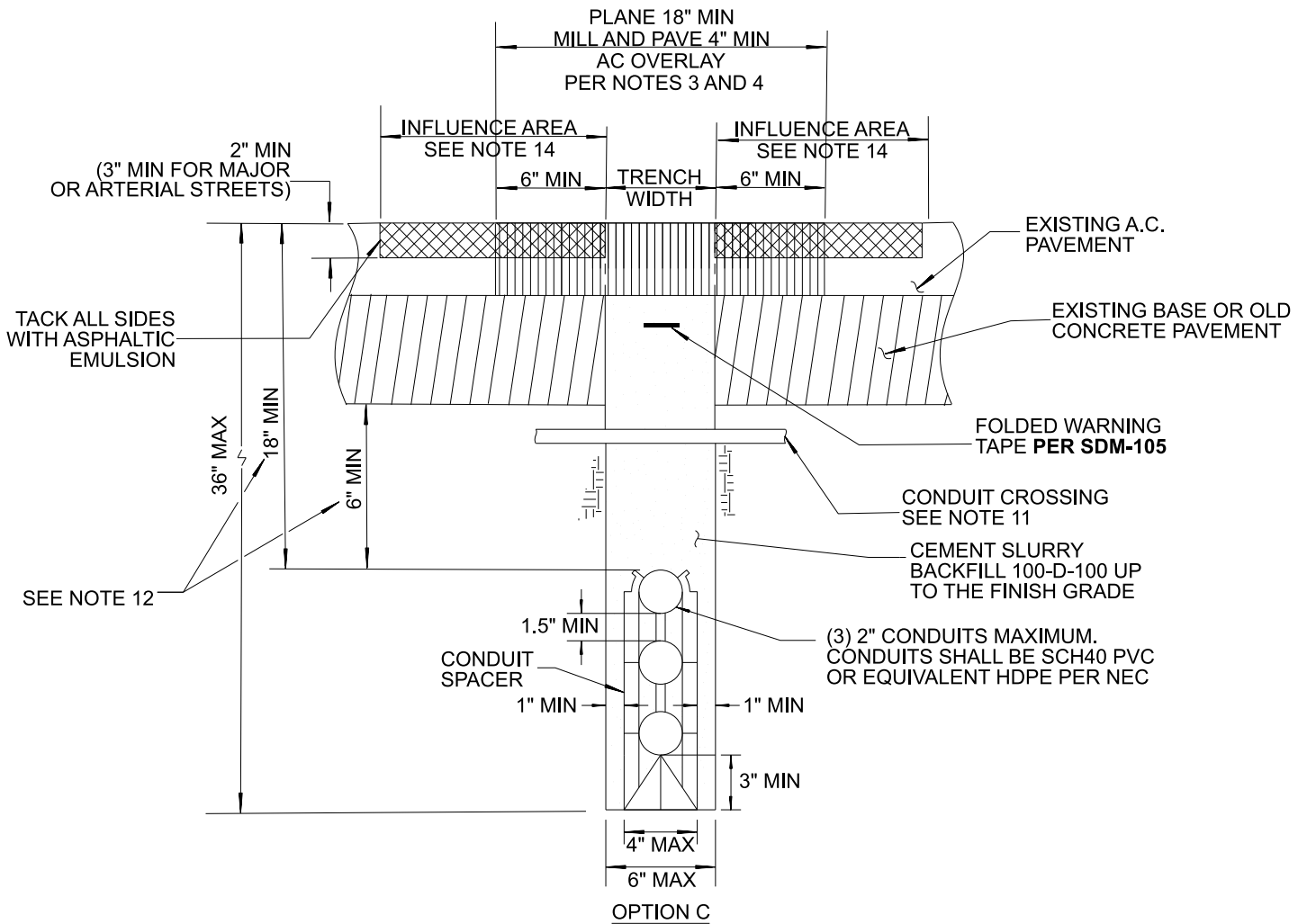

**NOTES (OPTION C):**

1. NEW TRENCH LOCATION SHALL BE 36 INCHES MINIMUM AND 72 INCHES MAXIMUM FROM LIP OF GUTTER, AND AT LEAST 36 INCHES CLEAR FROM ANY CITY UNDERGROUND FACILITIES.
  - A. THE CONTRACTOR SHALL CONTACT THE ENGINEER TO INSPECT AND APPROVE THE TRAFFIC CONTROL PLAN PRIOR TO START OF EXCAVATION IN A BICYCLE LANE. ENSURE ADEQUATE PROVISIONS HAVE BEEN INCLUDED FOR BICYCLE TRAFFIC INCLUDING BICYCLE DETOURS, IF APPLICABLE.
  - B. WHEN THE TRENCH AND/OR INFLUENCE AREA IS LOCATED WITHIN THE BICYCLE LANE, THE CONTRACTOR MUST PAVE THE FULL WIDTH OF THE BICYCLE LANE TO THE FACE OF CURB (I.E. GRIND AND OVERLAY) WITHIN SEVEN (7) CALENDAR DAYS OF AFTER THE INITIAL EXCAVATION. AT NO TIME SHALL A PARALLEL CUT OR SEAM EXIST IN THE BICYCLE LANE AS A FINAL RESTORATION.
  - D. THE CONTRACTOR SHALL PERFORM TRENCHING IN THE BICYCLE LANE IN ROAD SEGMENTS NOT TO EXCEED 500 LINEAR FEET PER SEGMENT. THE CONTRACTOR SHALL FULLY COMPLETE THE WORK ON EACH SEGMENT PRIOR TO STARTING THE NEXT SEGMENT.
2. CEMENT SLURRY BACKFILL SHALL BE THOROUGHLY CONSOLIDATED, HAVE A MAXIMUM SLUMP OF 4 INCHES. FLY ASH MEETING THE REQUIREMENTS OF 201-1.2.5.3 MAY BE ADDED (NOT AS A SUBSTITUTE) TO THE MINIMUM CEMENT REQUIREMENTS. SLURRY COMBINED GRADING SHALL MEET REQUIREMENTS OF 201-1.3.2 (A) GRADING D.

SEE ADDITIONAL NOTES ON SHEET 6

SHEET 5 OF 6

REVISION	BY	APPROVED	DATE	CITY OF SAN DIEGO - STANDARD DRAWING	RECOMMENDED BY THE CITY OF SAN DIEGO STANDARDS COMMITTEE
ORIGINAL		BAHMANIAN	04/86		
UPDATED	AA	J. NAGELVOORT	02/16		
UPDATED	LS	M. GIBSON	05/17		
REDRAFTED	CD	J. NAGELVOORT	09/18		
UPDATED	LS	J. NAGELVOORT	04/21		
UPDATED	RC	R. AMEN	10/23		
				DRAWING NUMBER	<b>SDG-117C</b>

**NOTES (CONTINUED FOR OPTION C):**

3. BALL DROP TEST PER ASTM D6024 SHALL BE PERFORMED ON SLURRY AND ACHIEVE A MAXIMUM INDENTATION DIAMETER OF 3 INCHES PRIOR TO PLACEMENT OF ASPHALT CONCRETE. SLURRY PLACED IN NARROW TRENCHES WHERE BALL DROP TEST CANNOT BE PERFORMED SHALL BE CURED A MINIMUM OF 48 HOURS PRIOR TO PLACEMENT OF ASPHALT CONCRETE. PERMANENT RESURFACING SHALL BE COMPLETED IN NO MORE THAN 7 DAYS AFTER PLACEMENT OF CEMENT SLURRY.
4. DURING PLACEMENT, CONCAVE SLURRY SURFACE WITH A SHOVEL TO 1/2 INCH - 1 INCH DEPTH.
5. MINIMUM SPECIFIED SEPARATIONS MUST BE MAINTAINED UNTIL SLURRY HAS FULLY CURED. IT IS THE RESPONSIBILITY OF THE CONTRACTOR TO ENSURE THE CONDUIT DOES NOT SHIFT HORIZONTALLY OR FLOAT VERTICALLY IN THE TRENCH DURING THE APPLICATION OF THE SLURRY. SPOT POUR ONE SACK SLURRY OVER CONDUIT AT 25 FOOT INTERVALS TO PREVENT CONDUIT FROM FLOATING.
6. CUTS SHALL BE STRAIGHT. EXISTING A.C. PAVEMENT WILL NOT REQUIRE SAW CUTTING WHEN USING ROCKWHEEL FOR EXCAVATION PROVIDED THAT A SMOOTH SURFACE IS PRODUCED.
7. TRENCH SHALL BE MILLED TO A DEPTH OF 4 INCHES AND A MINIMUM OF 18 INCHES WIDE OR 12 INCHES WIDER THAN TRENCH WIDTH, WHICHEVER IS GREATER, AND RESURFACED WITH 1/2 INCH TYPE III CLASS C2 ASPHALT.
8. WHEN PCC TRENCH RESURFACING IS DIRECTED BY CITY ENGINEER, SHOWN ON THE PLANS, OR REQUIRED FOR A PCC SURFACED STREET, FOR ASPHALT STREETS **SEE SDG-107** (NOTE #3) AND FOR CONCRETE SURFACED STREETS **SEE SDG-108**.
9. FOR PLACEMENT OF ADDITIONAL CONDUITS THAT EXCEED THE MAXIMUM ALLOWABLE TRENCH DIMENSIONS IN **SDG-117C** USE **SDG-119**.
10. ALLOW THREE HOURS MINIMUM FOR ONE SACK SLURRY TRENCH BACKFILL CURE TIME FOR TRENCHES PARALLEL TO THE STREET BEFORE OPENING TO TRAFFIC.
11. SLEEVE EXISTING CONDUITS AT CROSSING.
12. TOP OF CONDUIT SHALL BE 18" MINIMUM FROM TOP OF PAVEMENT OR 6" MINIMUM FROM BOTTOM OF PAVEMENT SECTION, WHICHEVER IS GREATER.
13. CONDUIT DUCT SPACERS SHALL BE USED TO MAINTAIN A 3 INCH MINIMUM SEPARATION FROM THE BOTTOM OF THE TRENCH AND 1 INCH SEPARATIONS FROM THE SIDES OF THE TRENCH TO INSURE SLURRY ENCAPSULATION OF THE CONDUIT PACKAGE.
14. SPACERS SHALL BE PLACED EVERY 6 FEET ON CENTER ALONG THE ALIGNMENT OF THE CONDUIT.
15. CLEARANCE SEPARATIONS BETWEEN DRY AND WET UTILITIES PER CALIFORNIA PUBLIC UTILITY CODE GENERAL ORDER 128 SHALL BE MAINTAINED.
16. ASPHALT OVERLAY THE ENTIRE LENGTH OF THE TRENCH INCLUDING THE INFLUENCE AREA AROUND THE PERIMETER OF THE EXCAVATION PER TABLE 1 IN SDG-105.
  - A. IF THE TRENCH OR EXCAVATION INFLUENCE AREA ENTERS A BICYCLE LANE, THE ENTIRE WIDTH OF THE BICYCLE SHALL BE ASPHALT OVERLAYED AND RESTRIPEDED FOR THE LENGTH OF THE TRENCH INCLUDING EXCAVATION INFLUENCE AREA. REPLACE IN KIND ANY EXISTING DELINEATORS.

SHEET 6 OF 6

REVISION	BY	APPROVED	DATE	CITY OF SAN DIEGO – STANDARD DRAWING  <b>PAVEMENT RESTORATION FOR ASPHALT CONCRETE SURFACED STREETS - MINOR EXCAVATION OPTION C - THREE CONDUITS</b>	RECOMMENDED BY THE CITY OF SAN DIEGO STANDARDS COMMITTEE
ORIGINAL		BAHMANIAN	0486		<b>DRAFT</b>
UPDATED	AA	J. NAGELVOORT	02/16		COORDINATOR R.C.E. 81047 DATE
UPDATED	LS	M. GIBSON	05/17		<b>SDG-117C</b>
REDRAFTED	CD	J. NAGELVOORT	09/18		
UPDATED	LS	J. NAGELVOORT	04/21		
UPDATED	RC	R. AMEN	10/23		



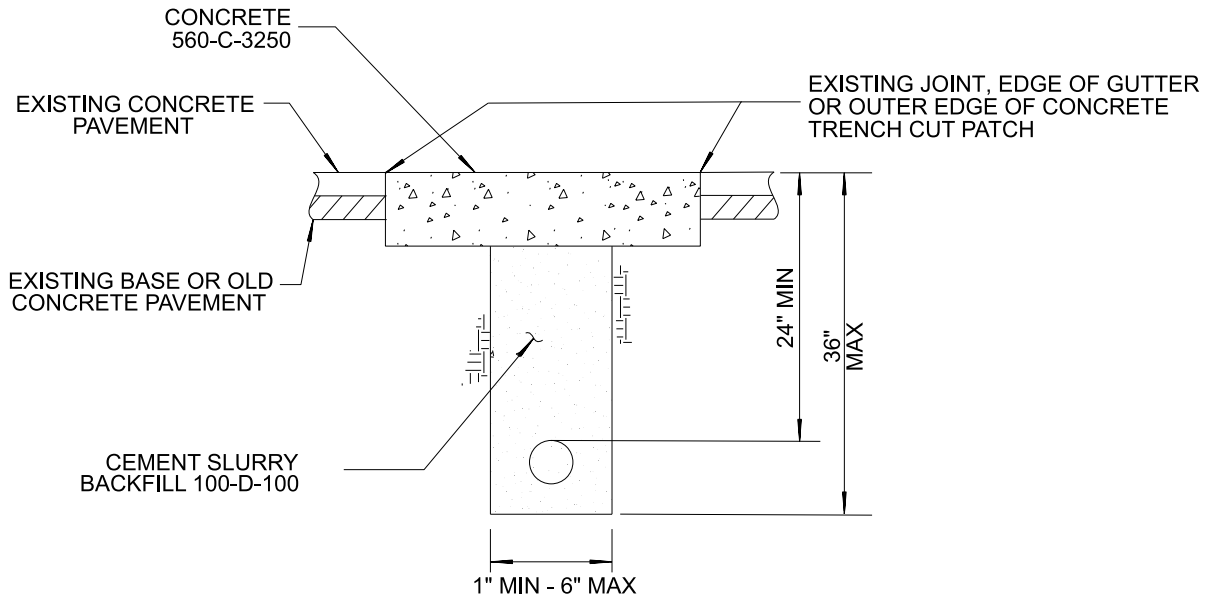

**NOTES:**

1. CEMENT SLURRY BACKFILL SHALL BE THOROUGHLY CONSOLIDATED, HAVE A MAXIMUM SLUMP OF 4 INCHES, AND MAY CONTAIN 30% MAXIMUM 3/8" ROCK.
2. CONCRETE SHALL BE PLACED AND FINISHED IN ACCORDANCE WITH 306-6. CONCRETE MAY BE PLACED IMMEDIATELY FOLLOWING SLURRY BACKFILL
3. CONCRETE TRENCH COVER SHALL BE A MINIMUM OF 5 1/2" THICK IN ALLEY OR LOCAL RESIDENTIAL STREETS AND 7" THICK IN ALL OTHER STREETS. **SEE NOTE #5 IN SDG-108** FOR CONCRETE CLASS OPTIONS AND CURING REQUIREMENTS.
4. EXISTING CONCRETE PAVEMENT WILL REQUIRE SAW CUTTING.
5. FOR ELECTRICAL SUPPLY CABLES, SEE CALIFORNIA PUBLIC UTILITY COMMISSION GENERAL ORDER NO. 128, RULE 33.4 CLEARANCES AND DEPTHS.
6. FOR DRY UTILITIES (ELECTRICAL, COMMUNICATION, GAS, ETC.) **SEE SDG-119**.
7. CONCRETE PAVEMENT RESTORATION SHALL EXTEND BEYOND THE EDGE OF THE TRENCH CUT TO THE NEAREST JOINT (FULL WIDTH OF CONCRETE PANEL, JOINT TO JOINT AROUND THE PERIMETER OF THE EXCAVATION).
  - A. FOR CONCRETE PAVEMENT WITH EXISTING TRENCH CUT PATCHES, CONCRETE PAVEMENT RESTORATION SHALL INCLUDE THE EXISTING TRENCH CUT PATCHES, IF THOSE PATCHES ARE WITHIN 4'-0" OF THE PROPOSED CONCRETE PANEL.
  - B. IF THE TRENCH CUT IS IN ALLEY APRON, CONCRETE RESTORATION SHALL BE TO THE NEAREST JOINT OR REPLACE ENTIRE ALLEY APRON IF NO JOINT. FOR NON-STANDARD ALLEY, INSTALL NEW CONCRETE PAVEMENT AS NEW JOINT CAN BE INSTALLED TO THE EXTEND OF THE RIGHT-OF-WAY.
8. FINAL STREET RESTORATION SHALL BE COMPLETED WITHIN 180 CALENDAR DAYS AFTER COMPLETION OF TRENCH WORK WITHIN A STREET SEGMENT.

REVISION	BY	APPROVED	DATE	CITY OF SAN DIEGO – STANDARD DRAWING	RECOMMENDED BY THE CITY OF SAN DIEGO STANDARDS COMMITTEE	
ORIGINAL		BAHMANIAN	04/86		<b>PAVEMENT RESTORATION FOR CONCRETE SURFACED STREETS AND ALLEYS - MINOR EXCAVATION</b>	<b>DRAFT</b>
UPDATED	KA	J. NAGELVOORT	08/13	COORDINATOR		R.C.E. 81047
UPDATED	AB	J. NAGELVOORT	02/16	DATE		
REDRAFTED	CD	J. NAGELVOORT	09/18	DRAWING		<b>SDG-118</b>
UPDATED	HE	R. AMEN	10/23	NUMBER		

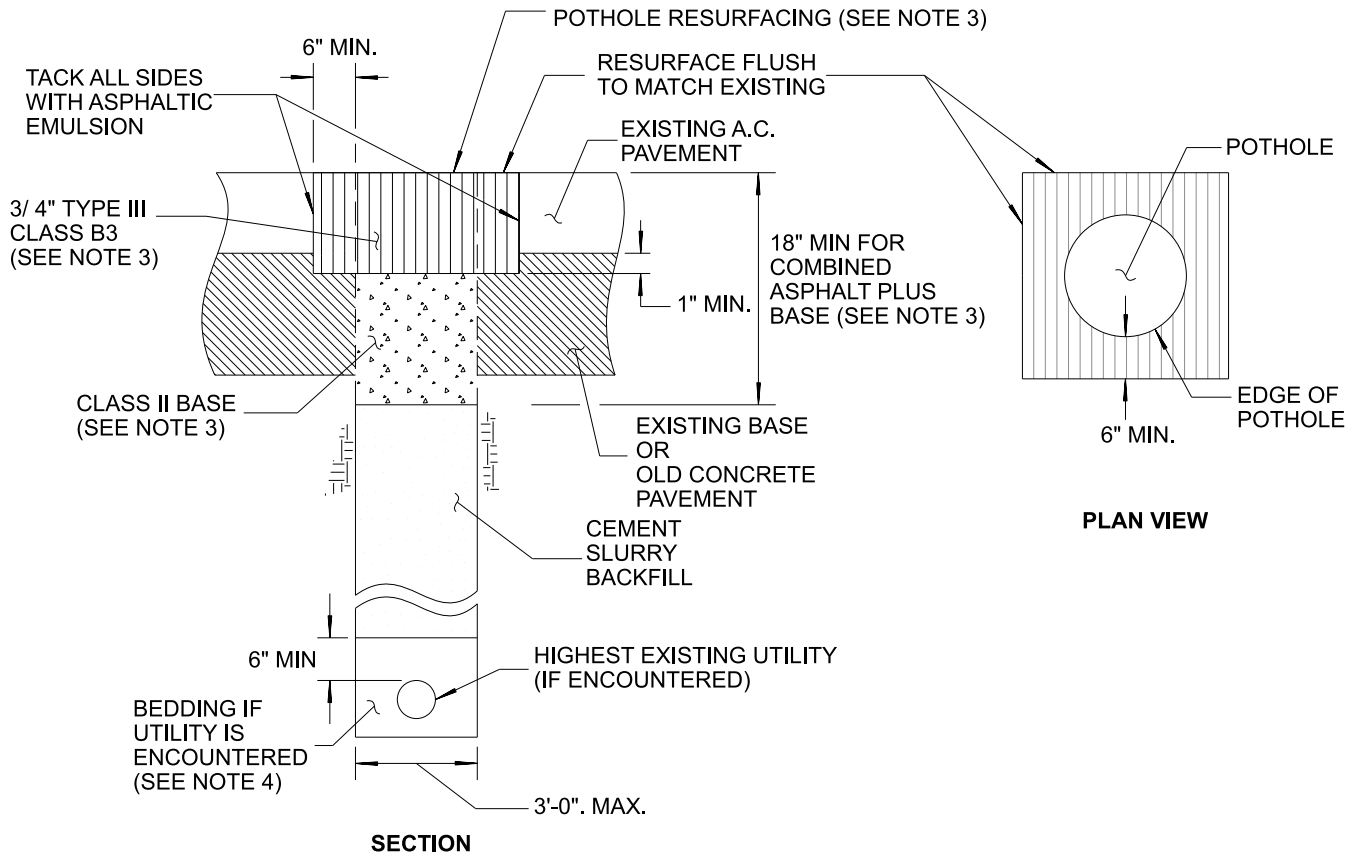

**NOTES:**

1. CEMENT SLURRY BACKFILL SHALL BE THOROUGHLY CONSOLIDATED, AND HAVE A MAXIMUM SLUMP OF 4 INCHES. FLY ASH MEETING THE REQUIREMENTS OF 201-1.2.5.3 MAY BE ADDED (NOT AS A SUBSTITUTE) TO THE MINIMUM CEMENT REQUIREMENTS. SLURRY COMBINED GRADING SHALL MEET REQUIREMENTS OF 201-1.3.2 GRADING D. CEMENT SLURRY BACKFILL SHALL BE 100-D-100.
2. SLURRY SHALL BE CURED A MINIMUM OF 48 HOURS PRIOR TO PLACEMENT OF CLASS II BASE AND ASPHALT CONCRETE. RESURFACING SHALL BE COMPLETED IN NO MORE THAN 7 DAYS AFTER PLACEMENT OF CEMENT SLURRY.
3. ALL ASPHALT STREET RESURFACING SHALL EXTEND A MINIMUM OF 6 INCHES BEYOND EDGE OF POTHOLE OR EXPLORATORY EXCAVATION, AS SHOWN. ASPHALT THICKNESS TO EQUAL EXISTING AC PAVEMENT PLUS 1 INCH (4 INCHES MINIMUM TO 9 INCHES MAXIMUM). COMBINED ASPHALT PLUS BASE SHALL BE 18 INCHES MINIMUM.
4. IF UTILITY IS ENCOUNTERED, AS LISTED BELOW, PLACE BEDDING A MINIMUM OF 6 INCHES ABOVE UTILITY.
  - A. WATER UTILITY: SE 50 SAND
  - B. SEWER UTILITY: 3/ 8" MAXIMUM AGGREGATE
  - C. DRY UTILITY: SE 50 SAND
5. FOR PCC SURFACED STREETS, **SEE SDG-108** FOR RESURFACING. FOR POTHOLE AND EXPLORATORY EXCAVATION LARGER THAN 3'-0" ON ASPHALT CONCRETE SURFACED STREETS, SEE SDG-107 FOR RESURFACING.
6. POTHOLE OR EXPLORATORY EXCAVATION IN BIKE LANES SHALL BE APPROVED BY THE CITY. IF APPROVED, THE ENTIRE WIDTH OF THE BIKE LANE SHALL BE RESURFACED, AT A MINIMUM LENGTH OF 6 FEET.
7. TEMPORARY RESURFACING IS ALLOWED IF CONSTRUCTION WILL BE PERFORMED WITHIN 60 DAYS AFTER POTHOLING WORK, IF POTHOLE OR EXPLORATORY EXCAVATION IS WITHIN THE NEW TRENCH LIMITS, AND **IF APPROVED BY THE CITY**. MATERIAL FOR TEMPORARY RESURFACING **SHALL BE APPROVED BY THE CITY**. SEE NOTE 3 FOR LIMITS AND DEPTH.
8. PAVEMENT CORES SHALL NOT BE GREATER THAN 3'-0" IN DIAMETER, AND SHALL NOT BE SPACED CLOSER THAN 3 FEET BETWEEN CORES, EDGE TO EDGE.
9. SEE SHEET 2 FOR TYPE B - KEYHOLE METHOD.

SHEET 1 OF 2

REVISION	BY	APPROVED	DATE	CITY OF SAN DIEGO - STANDARD DRAWING	RECOMMENDED BY THE CITY OF SAN DIEGO STANDARDS COMMITTEE
ORIGINAL	CD	J. NAGELVOORT	11/17		
UPDATED	CD	J. NAGELVOORT	09/18	<b>36" AND SMALLER POTHOLE AND EXPLORATORY EXCAVATION - TYPE A PAVEMENT REPAIR</b>	<b>DRAFT</b>
UPDATED	FM	R. AMEN	09/23		
				COORDINATOR R.C.E. 81047 DATE	
				DRAWING NUMBER <b>SDG-123</b>	

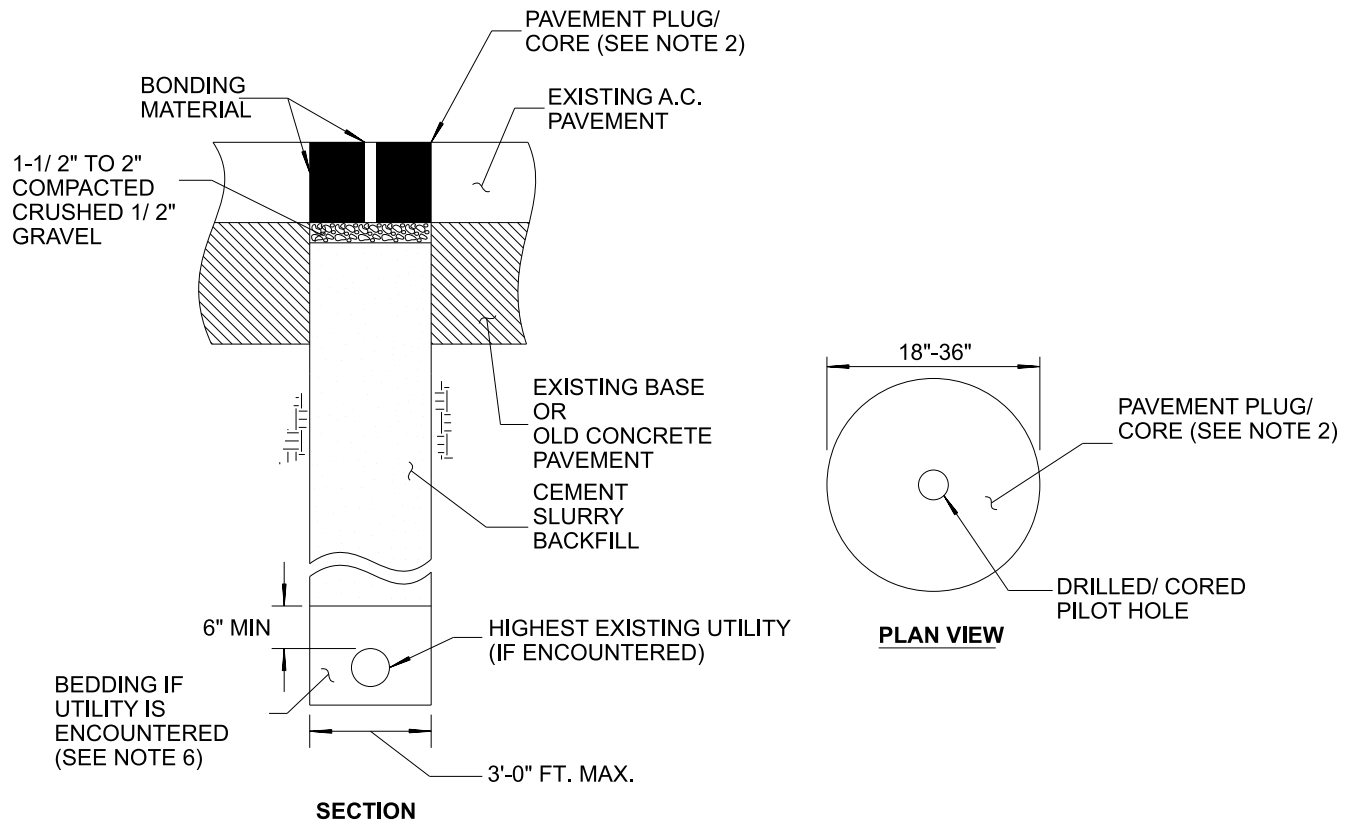

**NOTES:**

1. PAVEMENT CORE TO BE REINSTATED SHALL BE A MINIMUM OF 4 INCHES THICK AND SHALL NOT CONTAIN JOINTS OR CRACKS WHICH MAY CAUSE IT TO BREAK AND SPALL. OTHERWISE, TYPE "A" PER SHEET 1 SHALL BE USED **AS DIRECTED BY CITY ENGINEER.**
2. CUT, REMOVE, AND REINSTATE PAVEMENT CORE, FLUSH WITH EXISTING PAVEMENT. THE REMOVED PAVEMENT CORE/ PLUG WITH ASPHALT AND CONCRETE BASE SHALL BE UTILIZED AND REINSTALLED IN GOOD CONDITION.
3. BONDING MATERIAL SHALL BE AS SPECIFIED **PER CITY APPROVED MATERIALS LIST.**
4. CEMENT SLURRY BACKFILL SHALL BE THOROUGHLY CONSOLIDATED, AND HAVE A MAXIMUM SLUMP OF 4 INCHES. FLY ASH MEETING THE REQUIREMENTS OF 201-1.2.5.3 MAY BE ADDED (NOT AS A SUBSTITUTE) TO THE MINIMUM CEMENT REQUIREMENTS. SLURRY COMBINED GRADING SHALL MEET REQUIREMENTS OF 201-1.3.2 GRADING D. CEMENT SLURRY BACKFILL SHALL BE 100-D-100.
5. SLURRY SHALL BE CURED A MINIMUM OF 48 HOURS PRIOR TO PLACEMENT OF CLASS II BASE AND ASPHALT CONCRETE. RESURFACING SHALL BE COMPLETED IN NO MORE THAN 7 DAYS AFTER PLACEMENT OF CEMENT SLURRY.
6. IF UTILITY IS ENCOUNTERED, AS LISTED BELOW, PLACE BEDDING A MINIMUM OF 6 INCHES ABOVE UTILITY.
  - A. WATER UTILITY: SE 50 SAND
  - B. SEWER UTILITY: 3/ 8" MAXIMUM AGGREGATE
  - C. DRY UTILITY: SE 50 SAND
7. FOR CONCRETE SURFACED STREETS, **SEE SDG-108** FOR RESURFACING. FOR POTHOLE AND EXPLORATORY EXCAVATION LARGER THAN 3'-0" ON ASPHALT CONCRETE SURFACED STREETS, SEE SDG-107 FOR RESURFACING.
8. POTHOLE OR EXPLORATORY EXCAVATION IN BIKE LANES **SHALL BE APPROVED BY THE CITY.**
9. PAVEMENT CORES SHALL NOT BE GREATER THAN 3'-0" INCHES IN DIAMETER, AND SHALL NOT BE SPACED CLOSER THAN 3 FEET BETWEEN CORES, EDGE TO EDGE.

SHEET 2 OF 2

REVISION	BY	APPROVED	DATE	CITY OF SAN DIEGO – STANDARD DRAWING	RECOMMENDED BY THE CITY OF SAN DIEGO STANDARDS COMMITTEE	
ORIGINAL	CD	J. NAGELVOORT	11/17		<b>36" AND SMALLER EXPLORATORY EXCAVATION POTHOLE - TYPE B KEYHOLE METHOD</b>	<b>DRAFT</b>
UPDATED	CD	J. NAGELVOORT	0918	COORDINATOR R.C.E. 81047 DATE		
UPDATED	FM	R. AMEN	0923	DRAWING NUMBER		<b>SDG-123</b>

**NOTES:**

1. CLEARANCE SEPARATIONS BETWEEN DRY AND WET UTILITIES SHALL BE MAINTAINED PER WATER, SEWER, AND DRAINAGE DESIGN GUIDELINES, VARIANCES WILL REQUIRE DEVIATION FROM STANDARDS.
2. **PERMITTING REQUIREMENTS:** ALL MICROTRENCH PERMITS REQUIRE A DEVELOPMENT SERVICES DEPARTMENT DIGITAL SUBMISSION WITH A GEOSPATIAL ALIGNMENT PER DEVELOPMENT SERVICES DEPARTMENT FORMAT REQUIREMENTS.
3. **CONDUIT ANCHORING:** CONTRACTOR MUST PROVIDE THEIR METHOD OF WEIGHING / ANCHORING DOWN CONDUITS IN THEIR PERMIT. TO PREVENT CONDUITS FROM FLOATING, AND TO MAINTAIN REQUIRED DEPTH FOR TOP OF CONDUIT.
4. **MICROTRENCHING USAGE:** MICROTRENCHING PER SDG-165A AND / OR SDG-165B SHALL BE ON ASPHALT STREETS ONLY. MICROTRENCHING SHALL NOT BE PERMITTED IN OR THROUGH EXISTING CONCRETE PAVED STREETS, PARKWAYS, CURB, GUTTER, CROSS GUTTER, BUS PAD, SIDEWALK, FLOATING CURB EXTENSION, BUS BULB, TRUCK PILLOW, RAISED CROSSWALK, ISLAND, MINI- ROUNDABOUT, OR SIMILAR ELEMENTS. MICROTRENCHING MAY BE PERMITTED, AT THE CITY'S DISCRETION, IN OR THROUGH EXISTING IMPROVEMENTS AND SPECIAL PAVEMENTS (SUCH AS DECORATIVE ASPHALT PAVING, AND PERPENDICULAR TO SPEED BUMPS). EXISTING IMPROVEMENTS AND SPECIAL PAVEMENTS SHALL BE RESTORED IN KIND AS APPROVED BY THE CITY.
5. **DAMAGE TO EXISTING IMPROVEMENTS:** CONNECTION TO SERVICE LATERALS, JUNCTION BOXES, ETC. SHALL BE DONE SUCH THAT EXISTING IMPROVEMENTS ARE NOT DISTURBED, SETTLED, OR DAMAGED. ANY DAMAGE TO EXISTING IMPROVEMENTS BY PARALLEL OR PERPENDICULAR MICROTRENCHING ACTIVITIES SHALL BE RESTORED IN KIND AS APPROVED BY THE CITY. DAMAGE TO CONCRETE CURB, GUTTER, SIDEWALK, AND PAVEMENT SHALL BE REMOVED AND RESTORED IN ACCORDANCE WITH **SDG-156**.
6. **TRENCH CUTS:** CONTRACTOR SHALL MAKE ALL REASONABLE EFFORTS TO ACHIEVE STRAIGHT AND UNIFORM CUTS WITH NEAT EDGES. SELECTION OF CUTTING WHEEL SHALL BE SUCH THAT IT MINIMIZES DAMAGE TO THE ADJACENT AC SURFACE. RADII TRENCH CUTS SHALL HAVE NO MORE THAN 3 CUTS.
7. **MICROTRENCH WIDTH:** MICROTRENCH WIDTH SHALL BE A MINIMUM OF 1 INCH AND A MAXIMUM OF 2 ½ INCHES. TRENCHES WITH WIDTH GREATER THAN 2 ½ INCHES MUST FOLLOW **SDG-117** (NARROW TRENCH RESURFACING FOR ASPHALT CONCRETE SURFACE STREETS), WHICH REQUIRES A DIFFERENT BACKFILL MATERIAL. THE CITY MAY CHANGE THE PERMIT TO **SDG-117** BY AN AS-BUILT CHANGE IF THE TRENCH EXCEEDS 2 ½ INCHES IN CONSTRUCTION.
8. **MICROTRENCH ALIGNMENT OFFSET TO AN ADJACENT MICROTRENCH:** NO MICROTRENCHING SHALL BE LESS THAN 2 FEET FROM ADJACENT MICROTRENCHES (EDGE TO EDGE). THIS MAY REQUIRE THE CONTRACTOR TO POTHOLE TO VERIFY PARALLEL UTILITIES SIZE AND TRENCH WIDTH TO ENSURE PROPER SEPARATION.
9. **CONDUIT PLACEMENT IN TRENCH:** THE TOP OF HIGHEST CONDUIT SHALL BE 12 INCHES MINIMUM FROM TOP OF PAVEMENT OR 4 INCHES FROM BOTTOM OF PAVEMENT SECTION TO INCLUDE ASPHALT, BASE AND CTB, WHICHEVER IS GREATER.
10. **CONDUIT SIZE:** 2 INCH MAXIMUM CONDUIT SIZE SCH 40 PVC OR EQUIVALENT HDPE PER NATIONAL ELECTRICAL CODE.
11. **TRENCH IDENTIFICATION:** INSTALL FOLDED WARNING / IDENTIFICATION TAPE WARNING TAPE **PER SDM-105**. EACH TRENCH SHALL BE IDENTIFIED WITH A CALLOUT ON THE PULLBOX / VAULT / JUNCTION BOX LID WITH THE NAME OF THE OWNER OF THE MICROTRENCH.
12. **MICROTRENCH BACKFILL AND REQUIREMENTS TO OPEN THE STREET TO TRAFFIC:** ALL MICROTRENCHES SHALL BE COMPLETELY BACKFILLED WITH A CEMENT SAND SLURRY 2000 PSI MINIMUM AND 2% CALCIUM CHLORIDE TO FINISH GRADE. THIS IS AN INTERIM CONDITION AND CONTRACTOR SHALL FOLLOW CURING TIME REQUIREMENTS (PER NOTE 14) TO OPEN THE STREET TO TRAFFIC PRIOR TO COMPLETING PAVING REQUIREMENTS FOR FINAL RESTORATION.
13. **SLURRY VOID REDUCTION:** CONTRACTOR SHALL USE A VIBRATOR TO ENSURE SLURRY FILL WITHOUT VOIDS.
14. **SLURRY CURE TIME:** ALLOW A MINIMUM OF THREE HOURS FOR SLURRY TRENCH BACKFILL CURE TIME FOR TRENCHES PARALLEL TO THE STREET BEFORE OPENING TO TRAFFIC.

SEE ADDITIONAL NOTES ON SHEET 2

SHEET 1 OF 4

REVISION	BY	APPROVED	DATE	CITY OF SAN DIEGO – STANDARD DRAWING  <b>GENERAL MICROTRENCH NOTES</b>	RECOMMENDED BY THE CITY OF SAN DIEGO STANDARDS COMMITTEE  <b>DRAFT</b> _____ COORDINATOR R.C.E. 81047 DATE
ORIGINAL	HY	M. GIBSON	05/17		
REDRAFTED	CD	J. NAGELVOORT	09/18		
UPDATED	RC	R. AMEN	10/22		
UPDATED	FM	R. AMEN	09/23		
					DRAWING NUMBER <b>SDG-165</b>

**NOTES (CONTINUED):**

- 15. **FINAL MICROTRENCH RESTORATION:** WITHIN 7 DAYS OF PLACING THE SLURRY BACKFILL TO GRADE, MILL THE SLURRY BACKFILL AND EXISTING PAVEMENT A MINIMUM WIDTH OF 18 INCHES INCLUDING THE EXCAVATION INFLUENCE AREA PER TABLE 1 IN SDG-105 TO A DEPTH OF 4 INCHES AND RESURFACE WITH 1/2 INCH TYPE III CLASS C2 ASPHALT. TACK ALL EDGES OF THE MILLED AREA WITH ASPHALTIC EMULSION.
- 16. **FINAL MICROTRENCH RESTORATION WHEN ADJACENT TO ANOTHER MICROTRENCH:** WHEN RESTORING A MICROTRENCH SEPARATED BY 2 FEET (EDGE TO EDGE) FROM ANY ADJACENT MICROTRENCH THE MICROTRENCH RESTORATION SHALL FOLLOW NOTE 15 FOR TRENCH RESTORATION AND **SDG-107** FOR FULL LIMITS OF THE PERMITTED ALIGNMENT TO MAINTAIN INFLUENCE AREA INTEGRITY.
- 17. **MICROTRENCHING IN BIKE LANES:** FOR THE WORK IN THE BIKE LANE, CONTRACTOR SHALL PROVIDE A POTHOLING PLAN FOR REVIEW WITH THE ENGINEER FOLLOWING PRE-CONSTRUCTION MEETING. THE BIKE LANE SHALL BE FULLY CLOSED AND APPROPRIATE TRAFFIC CONTROL PLAN AND SIGNAGE USED. MICROTRENCHING IN THE BIKE LANE REQUIRES THAT SLURRY BACKFILL BE COMPLETED BEFORE END OF APPROVED WORKDAY WITH CURING TIME PER NOTE 14. RESTORATION TO THE TRENCH SHALL BE PER NOTE 15.
- 18. **FINAL MICROTRENCH RESTORATION IN BIKE LANES:** THE CONTRACTOR SHALL RESTORE FULL WIDTH OF BIKE LANE TO THE FACE OF CURB AND PLACE 2 INCHES MIN OR 3 INCHES MIN (MAJOR OR ARTERIAL STREETS) THICKNESS OF ASPHALT PER **SDG-107**.

SHEET 2 OF 4

REVISION	BY	APPROVED	DATE	CITY OF SAN DIEGO – STANDARD DRAWING  <b>GENERAL MICROTRENCH NOTES</b>	RECOMMENDED BY THE CITY OF SAN DIEGO STANDARDS COMMITTEE  <b>DRAFT</b> _____ COORDINATOR R.C.E. 81047 DATE
ORIGINAL	HY	M. GIBSON	05/17		
REDRAFTED	CD	J. NAGELVOORT	09/18		
UPDATED	RC	R. AMEN	10/22		
UPDATED	FM	R. AMEN	09/23		
					DRAWING NUMBER <b>SDG-165</b>

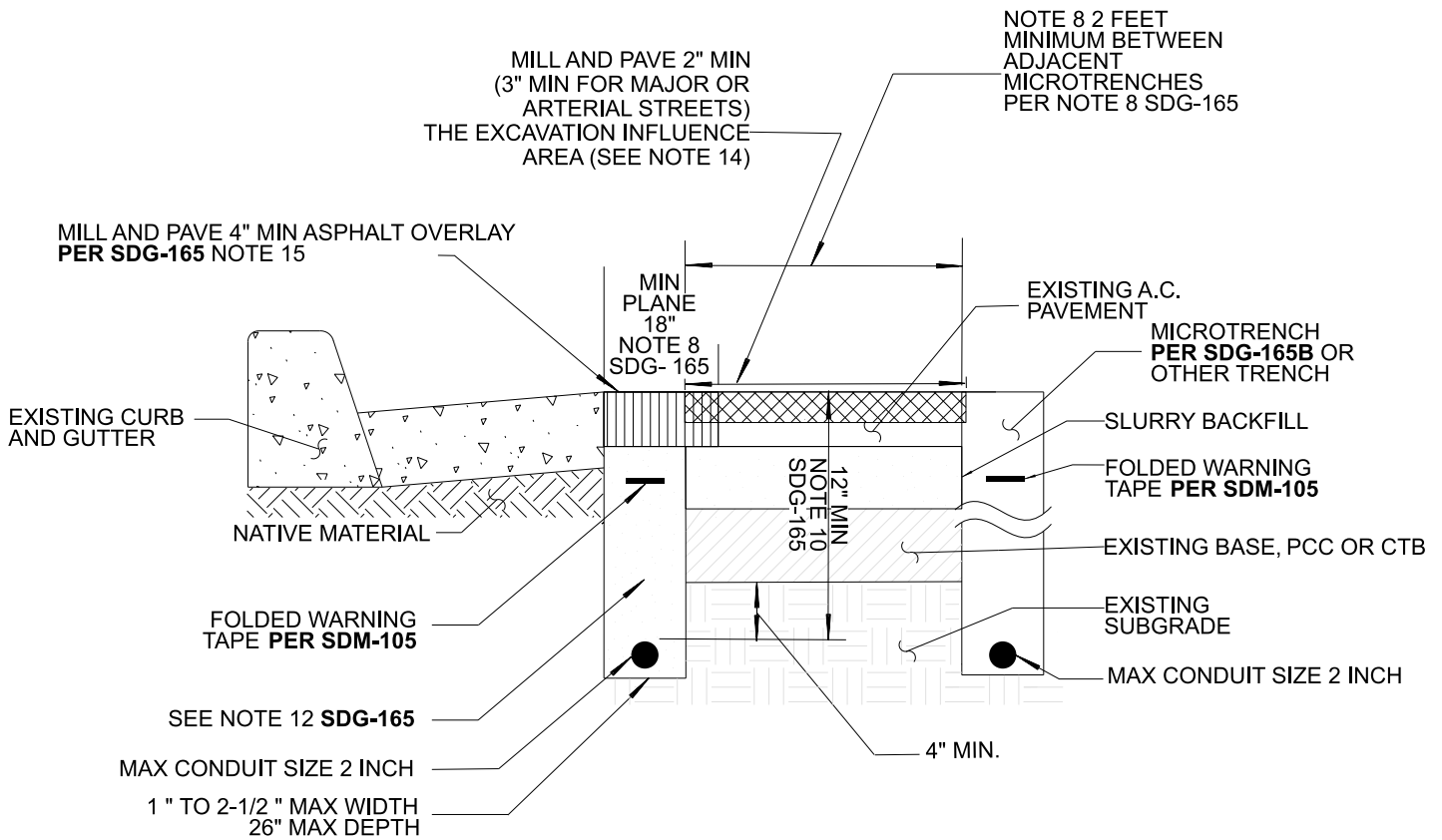

LEGEND ON PLANS:

— MTC — MICROTRENCH CONDUIT (MTC)

**NOTES:**

1. APPLICABLE WHERE CONCRETE GUTTER IS VISIBLE OR EXPOSED.
2. SHALL NOT BE APPLICABLE AT STREET INTERSECTIONS OR ALONG MEDIAN CURBS.
3. TRENCH LOCATION SHALL BE AT THE EDGE OF CURB.

SHEET 3 OF 4

REVISION	BY	APPROVED	DATE	CITY OF SAN DIEGO – STANDARD DRAWING	RECOMMENDED BY THE CITY OF SAN DIEGO STANDARDS COMMITTEE
ORIGINAL	HY	M. GIBSON	05/17		
REDRAFTED	CD	J. NAGELVOORT	09/18	<b>MICROTRENCH FOR DRY UTILITIES AT EDGE OF CURB AND GUTTER</b>	<b>DRAFT</b>
UPDATED	ED	R. AMEN	10/22		
UPDATED	FM	R. AMEN	09/23		
				COORDINATOR R.C.E. 81047 DATE	
				DRAWING NUMBER <b>SDG-165A</b>	

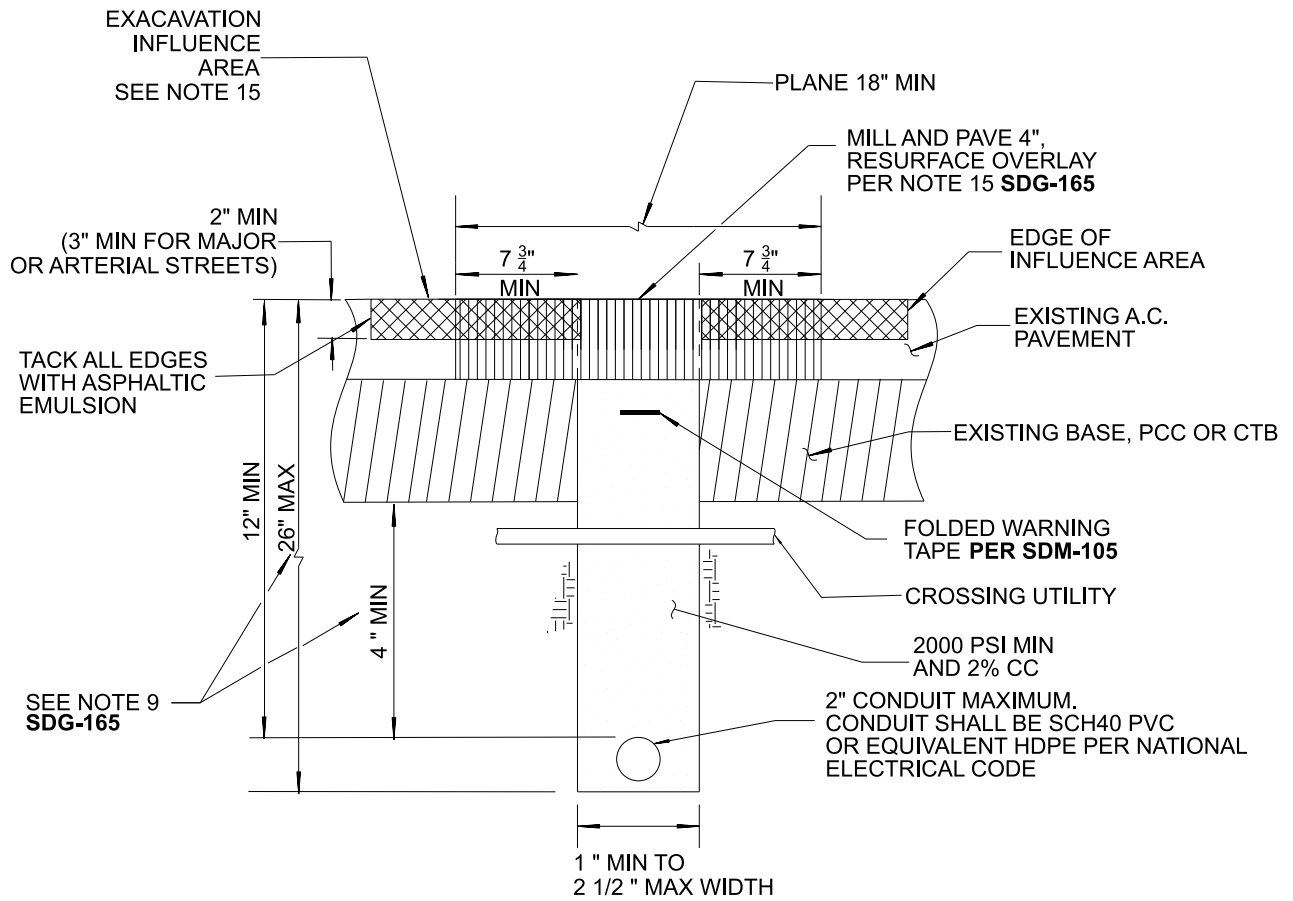

**NOTES:**

1. SHALL APPLY TO ALL MICROTRENCHING AT STREET INTERSECTIONS.
2. TRENCH LOCATION SHALL BE AT LEAST 9 INCHES FROM LIP OF GUTTER.
3. TRENCH SHALL BE AT LEAST 12 INCHES FROM ANY EXISTING CONCRETE STRUCTURE.

SHEET 4 OF 4

REVISION	BY	APPROVED	DATE	CITY OF SAN DIEGO – STANDARD DRAWING	RECOMMENDED BY THE CITY OF SAN DIEGO STANDARDS COMMITTEE
ORIGINAL	HY	M. GIBSON	05/17		
REDRAFTED	CD	J. NAGELVOORT	0918		
UPDATED	RC	R. AMEN	1022		
UPDATED	FM	R. AMEN	0923		
				DRAWING NUMBER	<b>SDG-165B</b>

**ATTACHMENT F**

**IN-USE OFF-ROAD DIESEL FUELED FLEET REGULATION (OFF-ROAD REGULATION)  
COMPLIANCE (CARB)**



## ATTACHMENT F

### IN-USE OFF-ROAD DIESEL FUELED FLEET REGULATION (OFF-ROAD REGULATION) COMPLIANCE (CARB)

The California Air Resources Board (CARB) approved amendments to the Off-Road Regulations which can be found at 13 California Code of Regulations (CCR) sections 2449, 2449.1, and 2449.2. These amendments apply to any person, business, or government agency who owns or operates within California any vehicles with a diesel-fueled or alternative diesel fueled off-road compression-ignition engine with maximum power (max hp) of 25 horsepower (hp) or greater provided that the vehicle cannot be registered and driven safely on-road or was not designed to be driven on-road, even if it has been modified so that it can be driven safely on-road. See 13 CCR section 2449 (b) for the full list of vehicles covered by these Off-Road Regulations.

Beginning **January 1, 2024**, Contractor shall be subject to the requirements below. No Contractor or public works awarding body, as applicable, shall enter into a contract with a fleet for which it does not have a valid Certificate of Reported Compliance for the fleet and its listed subcontractors, if applicable, prior to entering into a new or renewed contract with that fleet. Contractor shall comply with the following requirements:

- (1) For a project involving the use of vehicles subject to the Off-Road Regulation, Contractor must obtain copies of the valid Certificates of Reported Compliance, as described in 13 CCR section 2449(n), for the fleet selected for this Contract and their listed subcontractors, if applicable, prior to entering into a new or renewed contract with that fleet and provide copies of such Certificates of Reported Compliance to the City within 10 days of issuance of the Notice of Intent to Award letter. Contractor shall enter into a contract with a fleet for which it does not have a valid Certificates of Reported Compliance for the fleet and its listed subcontractors. City shall not enter into a contract with Contractor until all current Certificates of Reported Compliance for the fleet to be used on this Project are provided by Contractor.
- (2) The Certificates of Reported Compliance received by Contractor for this Project must be retained by Contractor for three years after the Project's completion. Upon request by CARB, these records must be provided to CARB within five business days of the request. Additionally, upon request by City, these records must be produced to City within five business days of the request.
- (3) For emergency contracts that meet the definition of "emergency operations" as defined in 13 CCR section 2449(c)(18), they are exempt from the requirements in 13 CCR section 2449(i)(1)-(3) and sections (1) and (2) above, but must still retain records verifying vehicles subject to the regulation that are operating on the "emergency operations" project are actually being operated on the project for "emergency operations" only. These records, as described in more detail below in section (B) must be retained by Contractor for three years after completion of the Project and upon request from either CARB or the City, Contractor shall provide those records to the requesting party within five business days. All other emergency contracts that

- A. "Emergency Operations" is defined as:
1. Any activity for a project conducted during emergency, life threatening situations, where a sudden, unexpected occurrence that poses a clear and imminent danger, requiring immediate action to prevent or mitigate the loss or impairment of life, health, property, or an essential public service; or in conjunction with any officially declared disaster or state of emergency, as declared by an authorized health officer, agricultural commissioner, fire protection officer, or other authorized health officer;
  2. Any activity for a project conducted by essential service utilities to provide electricity, natural gas, telephone, water, or sewer during periods of service outages and emergency; or
  3. Operations including repairing or preventing damage to roads, buildings, terrain, and infrastructure as a result of an earthquake, flood, storm, fire, other infrequent act of nature, or terrorism. Routine maintenance or construction to prevent public health risks does not constitute emergency operations under the Off-Road Regulations.
- B. The records retained by Contractor for "emergency operations" projects must include:
1. A description of the emergency;
  2. The address or a description of the specific location of the emergency;
  3. The dates on which the emergency operations were performed; and
  4. An attestation by the fleet that the vehicles are operated on the Project for "emergency operations" only.

Beginning **January 1, 2024**, Contractor is also subject to the requirements described in 13 CCR section 2449(j).

- (1) Between March 1 and June 1 of each year, Contractor must collect new valid Certificates of Reported Compliance for the current compliance year, as defined in 13 CCR section 2449(n), from all fleets that have an ongoing contract with Contractor as of March 1 of that year. Contractors shall not write contracts to evade this requirement.
- (2) Contractor shall only allow fleets with valid Certificates of Reported Compliance on the Contractor's job sites.
- (3) If Contractor discovers that any fleet intending to operate vehicles subject to this regulation for Contractor does not have a valid Certificate of Reported Compliance, as defined in 13 CCR section 2449(n), or if Contractor observes any noncompliant vehicles subject to the regulation on Contractor's job site, then Contractor must report the that to CARB at <https://calepacomplaints.secure.force.com/complaints/Complaint>, or email [dieselcomplaints@arb.ca.gov](mailto:dieselcomplaints@arb.ca.gov), for each fleet without a valid Certificate of Reported Compliance or each noncompliant vehicle, as applicable, within five business days of such discovery. See 13 CCR 2449(n) for the information required to be disclosed to CARB when reporting non-compliance.

(4) Upon request by CARB, Contractor must immediately disclose to CARB the name and contact information of each responsible party for all vehicles subject to this regulation operating at the job site or for Contractor.

(5) Contractor shall prominently display signage for any project where vehicles subject to this Off-Road Regulation will operate for 8 calendar days or more. The signage must be posted by the eighth calendar day from which the first vehicle operates. The signage will be in lettering larger than size 14-point type and displayed in a conspicuous place where notices to employees are customarily posted at the job site or where there is employee foot traffic. If one of the above locations is also viewable by the public, it should be posted at that location. An exemption to this posting requirement is permitted if the operational time of a project is 7 calendar days or less. The signage must include the following language, verbatim:

(A) Who does the In-Use Off-Road Regulation Apply to?

The In-Use Off-Road Diesel-Fueled Fleets Regulation (Off-Road Regulation) applies to all self-propelled off-road diesel vehicles 25 horsepower or greater and most two-engine vehicles (except on-road two-engine sweepers) owned or operated in California. This includes vehicles that are rented or leased (rental or leased fleets)."

(B) "In-Use Off-Road Regulation Requirements

Idling Limit: Vehicles cannot idle longer than five minutes. There are exceptions for vehicles that need to idle to perform work.

Labeling: Vehicles must be labeled with a CARB assigned equipment identification number (EIN). The EIN shall be white on a red background, unless the vehicle is part of a captive attainment area fleet, in which case the EIN shall be white on a green background.

The EIN shall be located in clear view on both sides of the outside of the vehicle."

**ATTACHMENT G**  
**CONTRACT AGREEMENT**

**ATTACHMENT G**  
**CONTRACT AGREEMENT**

---

**CONSTRUCTION CONTRACT**

This Phase-Funded contract is made and entered into between THE CITY OF SAN DIEGO, a municipal corporation, herein called "City", and S.C. Valley Engineering, Inc., herein called "Contractor" for construction of **BAY HO IMPROV 2; Bid No. B-19104, B-19106;** in the total amount of **Seventeen Million Nine Hundred Fifteen Thousand Dollars and Zero Cents (\$17,915,000.00)**, which is comprised of the Base Bid plus Additive Alternate A, consisting of an amount not to exceed **\$4,000,000.00** for Phase I, **\$6,200,000.00** for Phase 2, **\$7,115,008.00** for Phase 3, and **\$599,992.00** for Phase 4.

IN CONSIDERATION of the payments to be made hereunder and the mutual undertakings of the parties hereto, City and Contractor agree as follows:

1. The following are incorporated into this contract as though fully set forth herein:
  - (a) The attached Faithful Performance and Payment Bonds.
  - (b) The attached Proposal included in the Bid documents by the Contractor.
  - (c) Reference Standards listed in the Instruction to Bidders and the Supplementary Special Provisions (SSP).
  - (d) Phased Funding Schedule Agreement.
  - (e) That certain documents entitled **BAY HO IMPROV 2**, on file in the office of the City Clerk as Document No. **B-19104, B-19106**, as well as all matters referenced therein.
2. The City wishes to construct this Project on a Phase-Funded basis. In accordance with Whitebook section 7-3.10, the City is only obligated to pay for Phase I; Contractor cannot begin, nor is the City financially liable for any additional Phases, unless and until Contractor is issued a Notice to Proceed for each additional Phase by the City.
3. The Contractor shall perform and be bound by all the terms and conditions of this contract and in strict conformity therewith shall perform and complete in a good and workmanlike manner **BAY HO IMPROV 2**, Bid Number **K-24-2247-DBB-3**, San Diego, California.
4. For such performances, the City shall pay to Contractor the amounts set forth at the times and in the manner and with such additions or deductions as are provided for in this contract, and the Contractor shall accept such payment in full satisfaction of all claims incident to such performances. (See WHITEBOOK, Section 7-3.10, Phased Funding Compensation).

**CONTRACT AGREEMENT (continued)**

- 5. No claim or suit whatsoever shall be made or brought by Contractor against any officer, agent, or employee of the City for or on account of anything done or omitted to be done in connection with this contract, nor shall any such officer, agent, or employee be liable hereunder.
- 6. This contract is effective as of the date that the Mayor or designee signs the agreement and is approved by the City Attorney in accordance with San Diego Charter Section 40.

**IN WITNESS WHEREOF**, this Agreement is signed by the City of San Diego, acting by and through its Mayor or designee, pursuant to Municipal Code §22.3102 authorizing such execution.

**THE CITY OF SAN DIEGO**

**APPROVED AS TO FORM**

By 

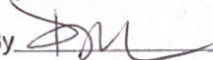
Mara W. Elliott, City Attorney  
By 

Print Name: Claudia C. Abarca  
Director  
Purchasing & Contracting Department

Print Name: Bonny Hen  
Deputy City Attorney

Date: May 30, 2024

Date: May 30, 2024

**CONTRACTOR**

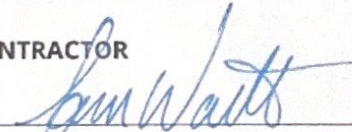
By 

Print Name: Sam Wathen

Title: President

Date: 04/09/2024

City of San Diego License No.: B2001005583

State Contractor's License No.: 624559-A

DEPARTMENT OF INDUSTRIAL RELATIONS (DIR) REGISTRATION NUMBER: 1000020727

## **CERTIFICATIONS AND FORMS**

The Bidder, by submitting its electronic bid, agrees to and certifies under penalty of perjury under the laws of the State of California, that the certifications, forms and affidavits submitted as part of this bid are true and correct.

## **BIDDER'S GENERAL INFORMATION**

To the City of San Diego:

Pursuant to "Notice Inviting Bids", specifications, and requirements on file with the City Clerk, and subject to all provisions of the Charter and Ordinances of the City of San Diego and applicable laws and regulations of the United States and the State of California, the undersigned hereby proposes to furnish to the City of San Diego, complete at the prices stated herein, the items or services hereinafter mentioned. The undersigned further warrants that this bid is not made in the interest of, or on behalf of, any undisclosed person, partnership, company, association, organization, or corporation; that the bid is genuine and not collusive or sham; that the bidder has not directly or indirectly induced or solicited any other bidder to put in a false or sham bid, and has not directly or indirectly colluded, conspired, connived, or agreed with any bidder or anyone else to put in a sham bid, or that anyone shall refrain from bidding; that the bidder has not in any manner, directly or indirectly, sought by agreement, communication, or conference with anyone to fix the bid price of the bidder or any other bidder, or to fix any overhead, profit, or cost element of the bid price, or of that of any other bidder, or to secure any advantage against the public body awarding the contract of anyone interested in the proposed contract; that all statements contained in the bid are true; and, further, that the bidder has not, directly or indirectly, submitted his or her bid price or any breakdown thereof, or the contents thereof, or divulged information or data relative thereto, or paid, and will not pay, any fee to any corporation, partnership, company, association, organization, bid depository, or to any member or agent thereof to effectuate a collusive or sham bid.

The undersigned bidder(s) further warrants that bidder(s) has thoroughly examined and understands the entire Contract Documents (plans and specifications) and the Bidding Documents therefore, and that by submitting said Bidding Documents as its bid proposal, bidder(s) acknowledges and is bound by the entire Contract Documents, including any addenda issued thereto, as such Contract Documents incorporated by reference in the Bidding Documents.



**NON-COLLUSION AFFIDAVIT TO BE EXECUTED BY BIDDER AND SUBMITTED WITH BID UNDER 23  
UNITED STATES CODE 112 AND PUBLIC CONTRACT CODE 7106**

State of California

County of San Diego

The bidder, being first duly sworn, deposes and says that he or she is authorized by the party making the foregoing bid that the bid is not made in the interest of, or on behalf of, any undisclosed person, partnership, company, association, organization, or corporation; that the bid is genuine and not collusive or sham; that the bidder has not directly or indirectly induced or solicited any other bidder to put in a false or sham bid, and has not directly or indirectly colluded, conspired, connived, or agreed with any bidder or anyone else to put in a sham bid, or that anyone shall refrain from bidding; that the bidder has not in any manner, directly or indirectly, sought by agreement, communication, or conference with anyone to fix the bid price of the bidder or any other bidder, or to fix any overhead, profit, or cost element of the bid price, or of that of any other bidder, or to secure any advantage against the public body awarding the contract of anyone interested in the proposed contract; that all statements contained in the bid are true; and further, that the bidder has not, directly or indirectly, submitted his or her bid price or any breakdown thereof, or the contents thereof, or divulged information or data relative thereto, or paid, and will not pay, any fee to any corporation, partnership, company association, organization, bid depository, or to any member or agent thereof to effectuate a collusive or sham bid.

## **CONTRACTOR CERTIFICATION**

---

### **DRUG-FREE WORKPLACE**

I hereby certify that I am familiar with the requirements of San Diego City Council Policy No. 100-17 regarding Drug-Free Workplace as outlined in the WHITEBOOK, Section 5-1.3, "Drug-Free Workplace", of the project specifications, and that;

This company has in place a drug-free workplace program that complies with said policy. I further certify that each subcontract agreement for this project contains language which indicates the subcontractor's agreement to abide by the provisions of subdivisions a) through c) of the policy as outlined.

## CONTRACTOR CERTIFICATION

---

### AMERICANS WITH DISABILITIES ACT (ADA) COMPLIANCE CERTIFICATION

I hereby certify that I am familiar with the requirements of San Diego City Council Policy No. 100-4 regarding the Americans With Disabilities Act (ADA) outlined in the WHITEBOOK, Section 5-1.2, "California Building Code, California Code of Regulations Title 24 and Americans with Disabilities Act". of the project specifications, and that:

This company has in place workplace program that complies with said policy. I further certify that each subcontract agreement for this project contains language which indicates the subcontractor's agreement to abide by the provisions of the policy as outlined.

## **CONTRACTOR CERTIFICATION**

---

### **CONTRACTOR STANDARDS – PLEDGE OF COMPLIANCE**

I declare under penalty of perjury that I am authorized to make this certification on behalf of the company submitting this bid/proposal, that as Contractor, I am familiar with the requirements of City of San Diego Municipal Code § 22.3004 regarding Contractor Standards as outlined in the WHITEBOOK, Section 5-1.4, ("Contractor Standards and Pledge of Compliance"), of the project specifications, and that Contractor has complied with those requirements.

I further certify that each of the Contractor's subcontractors has completed a Pledge of Compliance attesting under penalty of perjury of having complied with City of San Diego Municipal Code § 22.3004.

## **CONTRACTOR CERTIFICATION**

---

### **EQUAL BENEFITS ORDINANCE CERTIFICATION**

I declare under penalty of perjury that I am familiar with the requirements of and in compliance with the City of San Diego Municipal Code § 22.4300 regarding Equal Benefits Ordinance.

## **CONTRACTOR CERTIFICATION**

---

### **EQUAL PAY ORDINANCE CERTIFICATION**

Contractor shall comply with the Equal Pay Ordinance (EPO) codified in the San Diego Municipal Code (SDMC) at section 22.4801 through 22.4809, unless compliance is not required based on an exception listed in SDMC section 22.4804.

Contractor shall require all of its subcontractors to certify compliance with the EPO in their written subcontracts.

Contractor must post a notice informing its employees of their rights under the EPO in the workplace or job site.

By signing this Contract with the City of San Diego, Contractor acknowledges the EPO requirements and pledges ongoing compliance with the requirements of SDMC Division 48, section 22.4801 et seq., throughout the duration of this Contract.

## CONTRACTOR CERTIFICATION

---

### **IN-USE OFF-ROAD DIESEL FUELED FLEET REGULATION (OFF-ROAD REGULATION) COMPLIANCE**

I hereby certify that Contractor is familiar with the requirements 13 CCR 2449, 2449.1, and 2449.2, as well as Attachment F, CARB, and that Contractor shall comply with these requirements.

I further certify that each of the Contractor's listed subcontractors is familiar with these requirements and shall also comply.

## **CONTRACTOR CERTIFICATION**

---

### **PRODUCT ENDORSEMENT**

I declare under penalty of perjury that I acknowledge and agree to comply with the provisions of City of San Diego Administrative Regulation 95.65, concerning product endorsement. Any advertisement identifying or referring to the City as the user of a product or service requires the prior written approval of the City.



**AFFIDAVIT OF DISPOSAL**

(To be submitted upon completion of Construction pursuant to the contracts Certificate of Completion)

**WHEREAS**, on the \_\_\_\_\_ DAY OF \_\_\_\_\_, 2\_\_\_\_\_ the undersigned entered into and executed a contract with the City of San Diego, a municipal corporation, for:

**BAY HO IMPROV 2**

(Project Title )

as particularly described in said contract and identified as Bid No. **K-24-2247-DBB-3**; SAP No. (WBS) **B-19104, B-19106**; and **WHEREAS**, the specification of said contract requires the Contractor to affirm that "all brush, trash, debris, and surplus materials resulting from this project have been disposed of in a legal manner"; and **WHEREAS**, said contract has been completed and all surplus materials disposed of:

**NOW, THEREFORE**, in consideration of the final payment by the City of San Diego to said Contractor under the terms of said contract, the undersigned Contractor, does hereby affirm that all surplus materials as described in said contract have been disposed of at the following location(s)

and that they have been disposed of according to all applicable laws and regulations.

Dated this \_\_\_\_\_ DAY OF \_\_\_\_\_, \_\_\_\_\_.

By: \_\_\_\_\_  
Contractor

**ATTEST:**

State of \_\_\_\_\_ County of \_\_\_\_\_

On this \_\_\_\_\_ DAY OF \_\_\_\_\_, 2\_\_\_\_\_, before the undersigned, a Notary Public in and for said County and State, duly commissioned and sworn, personally appeared \_\_\_\_\_ known to me to be the \_\_\_\_\_ Contractor named in the foregoing Release, and whose name is subscribed thereto, and acknowledged to me that said Contractor executed the said Release.

Notary Public in and for said County and State

**LIST OF SUBCONTRACTORS**

**\*\*\* PROVIDED FOR ILLUSTRATIVE PURPOSES ONLY \*\*\* TO BE SUBMITTED IN ELECTRONIC FORMAT ONLY\*\*\* SEE INSTRUCTIONS TO BIDDERS, FOR FURTHER INFORMATION**

In accordance with the requirements of the "Subletting and Subcontracting Fair Practices Act", Section 4100, of the California Public Contract Code (PCC), the Bidder is to list below the name, address and license number of each Subcontractor who will perform work, labor, render services or specially fabricate and install a portion [type] of the work or improvement, in an amount of or in excess of 0.5% of the Contractor's total Bid. Failure to comply with this requirement may result in the Bid being rejected as non-responsive. The Contractor is to list only one Subcontractor for each portion of the Work. The Bidder's attention is directed to the Special Provisions – General; Paragraph 2-3 Subcontracts, which stipulates the percentage of the Work to be performed with the Bidder's own forces. The Bidder is to also list all SLBE, ELBE, DBE, DVBE, MBE, WBE, OBE, SDB, WoSB, HUBZone, and SDVOSB Subcontractors for which the Bidders are seeking recognition towards achieving any mandatory, voluntary, or both subcontracting participation percentages.

NAME, ADDRESS AND TELEPHONE NUMBER OF SUBCONTRACTOR	CONSTRUCTOR OR DESIGNER	SUBCONTRACTOR LICENSE NUMBER	TYPE OF WORK	DOLLAR VALUE OF SUBCONTRACT	MBE, WBE, DBE, DVBE, OBE, ELBE, SLBE, SDB, WoSB, HUBZone, OR SDVOSB®	WHERE CERTIFIED®	CHECK IF JOINT VENTURE PARTNERSHIP
Name: _____ Address: _____ City: _____ State: _____ Zip: _____ Phone: _____ Email: _____							
Name: _____ Address: _____ City: _____ State: _____ Zip: _____ Phone: _____ Email: _____							

- ① As appropriate, Bidder shall identify Subcontractor as one of the following and shall include a valid proof of certification (except for OBE, SLBE and ELBE):
- |   |        |  |         |
|---|--------|--|---------|
| Certified Minority Business Enterprise        | MBE    | Certified Woman Business Enterprise            | WBE     |
| Certified Disadvantaged Business Enterprise   | DBE    | Certified Disabled Veteran Business Enterprise | DVBE    |
| Other Business Enterprise                     | OBE    | Certified Emerging Local Business Enterprise   | ELBE    |
| Certified Small Local Business Enterprise     | SLBE   | Small Disadvantaged Business                   | SDB     |
| Woman-Owned Small Business                    | WoSB   | HUBZone Business                               | HUBZone |
| Service-Disabled Veteran Owned Small Business | SDVOSB |  |         |
- ② As appropriate, Bidder shall indicate if Subcontractor is certified by:
- |  |        |  |          |
|--|--------|--|----------|
| City of San Diego                                    | CITY   | State of California Department of Transportation | CALTRANS |
| California Public Utilities Commission               | CPUC   |  |          |
| State of California's Department of General Services | CADoGS | City of Los Angeles                              | LA       |
| State of California                                  | CA     | U.S. Small Business Administration               | SBA      |

**The Bidder will not receive any subcontracting participation percentages if the Bidder fails to submit the required proof of certification.**

**NAMED EQUIPMENT/MATERIAL SUPPLIER LIST**

**\*\*\* PROVIDED FOR ILLUSTRATIVE PURPOSES ONLY \*\*\* TO BE SUBMITTED IN ELECTRONIC FORMAT ONLY \*\*\* SEE INSTRUCTIONS TO BIDDERS FOR FURTHER INFORMATION**

NAME, ADDRESS AND TELEPHONE NUMBER OF VENDOR/SUPPLIER	MATERIALS OR SUPPLIES	DOLLAR VALUE OF MATERIAL OR SUPPLIES	SUPPLIER (Yes/No)	MANUFACTURER (Yes/No)	MBE, WBE, DBE, DVBE, OBE, ELBE, SLBE, SDB, WoSB, HUBZone, OR SDVOSB <sup>①</sup>	WHERE CERTIFIED <sup>②</sup>
Name: _____ Address: _____ City: _____ State: _____ Zip: _____ Phone: _____ Email: _____						
Name: _____ Address: _____ City: _____ State: _____ Zip: _____ Phone: _____ Email: _____						

- ① As appropriate, Bidder shall identify Vendor/Supplier as one of the following and shall include a valid proof of certification (except for OBE, SLBE and ELBE):
- |   |        |  |         |
|---|--------|--|---------|
| Certified Minority Business Enterprise        | MBE    | Certified Woman Business Enterprise            | WBE     |
| Certified Disadvantaged Business Enterprise   | DBE    | Certified Disabled Veteran Business Enterprise | DVBE    |
| Other Business Enterprise                     | OBE    | Certified Emerging Local Business Enterprise   | ELBE    |
| Certified Small Local Business Enterprise     | SLBE   | Small Disadvantaged Business                   | SDB     |
| Woman-Owned Small Business                    | WoSB   | HUBZone Business                               | HUBZone |
| Service-Disabled Veteran Owned Small Business | SDVOSB |  |         |
- ② As appropriate, Bidder shall indicate if Vendor/Supplier is certified by:
- |  |        |  |          |
|--|--------|--|----------|
| City of San Diego                                    | CITY   | State of California Department of Transportation | CALTRANS |
| California Public Utilities Commission               | CPUC   |  |          |
| State of California's Department of General Services | CADoGS | City of Los Angeles                              | LA       |
| State of California                                  | CA     | U.S. Small Business Administration               | SBA      |

**The Bidder will not receive any subcontracting participation percentages if the Bidder fails to submit the required proof of certification.**

## **ELECTRONICALLY SUBMITTED FORMS**

**FAILURE TO FULLY COMPLETE AND SUBMIT ANY OF THE FOLLOWING FORMS WILL DEEM YOUR BID NON-RESPONSIVE.**

**PLANETBIDS WILL NOT ALLOW FOR BID SUBMISSIONS WITHOUT THE ATTACHMENT OF THESE FORMS**

The following forms are to be completed by the bidder and submitted (uploaded) electronically with the bid in PlanetBids.

- A. BID BOND – See Instructions to Bidders, Bidders Guarantee of Good Faith (Bid Security) for further instructions**
- B. CONTRACTOR’S CERTIFICATION OF PENDING ACTIONS**
- C. SUBCONTRACTOR LISTING FOR ALTERNATE ITEMS**
- D. MANDATORY DISCLOSURE OF BUSINESS INTERESTS FORM**
- E. DEBARMENT AND SUSPENSION CERTIFICATION FOR PRIME CONTRACTOR**
- F. DEBARMENT AND SUSPENSION CERTIFICATION FOR SUBCONTRACTORS, SUPPLIERS AND MANUFACTURERS**

**BID BOND**

**See Instructions to Bidders, Bidder Guarantee of Good Faith  
(Bid Security)**

KNOW ALL MEN BY THESE PRESENTS,

That S.C. Valley Engineering, Inc. as Principal,  
and Western Surety Company as Surety, are held  
and firmly bound unto The City of San Diego hereinafter called "OWNER," in the sum  
of **10% OF THE TOTAL BID AMOUNT** for the payment of which sum, well and truly to be made, we  
bind ourselves, our heirs, executors, administrators, successors, and assigns, jointly and severally,  
firmly by these presents.

WHEREAS, said Principal has submitted a Bid to said OWNER to perform the WORK required under  
the bidding schedule(s) of the OWNER's Contract Documents entitled

Bay Ho Improv 2 Invitation # K-24-2247-DBB-3

NOW THEREFORE, if said Principal is awarded a contract by said OWNER and, within the time and in  
the manner required in the "Notice Inviting Bids" enters into a written Agreement on the form of  
agreement bound with said Contract Documents, furnishes the required certificates of insurance, and  
furnishes the required Performance Bond and Payment Bond, then this obligation shall be null and  
void, otherwise it shall remain in full force and effect. In the event suit is brought upon this bond by  
said OWNER and OWNER prevails, said Surety shall pay all costs incurred by said OWNER in such suit,  
including a reasonable attorney's fee to be fixed by the court.

SIGNED AND SEALED, this 26 day of February, 2024

S.C. Valley Engineering, Inc. (SEAL)  
(Principal)

By:  (Signature)

Western Surety Company (SEAL)  
(Surety)

By:  (Signature)  
Robert P. Dole, Attorney-in-Fact

(SEAL AND NOTARIAL ACKNOWLEDGEMENT OF SURETY)

# CALIFORNIA ALL-PURPOSE ACKNOWLEDGMENT

A notary public or other officer completing this certificate verifies only the identity of the individual who signed the document to which this certificate is attached, and not the truthfulness, accuracy, or validity of that document.

STATE OF CALIFORNIA

County of San Diego }

On February 26, 2024 before me, Patti Ewert, Notary Public,  
Date Insert Name of Notary exactly as it appears on the official seal

personally appeared Robert P. Dole

Name(s) of Signer(s)

who proved to me on the basis of satisfactory evidence to be the person(s) whose name(s) is/are subscribed to the within instrument and acknowledged to me that he/she/they executed the same in his/her/their authorized capacity(ies), and that by his/her/their signature(s) on the instrument the person(s), or the entity upon behalf of which the person(s) acted, executed the instrument.

I certify under PENALTY OF PERJURY under the laws of the State of California that the foregoing paragraph is true and correct.

Witness my hand and official seal.

Signature

Signature of Notary Public, Patti Ewert



Place Notary Seal Above

## OPTIONAL

Though the information below is not required by law, it may prove valuable to persons relying on the document and could prevent fraudulent removal and reattachment of the form to another document.

### Description of Attached Document

Title or Type of Document: \_\_\_\_\_

Document Date: \_\_\_\_\_ Number of Pages: \_\_\_\_\_

Signer(s) Other Than Named Above: \_\_\_\_\_

### Capacity(ies) Claimed by Signer(s)

Signer's Name: Robert P. Dole

- Individual  
 Corporate Officer — Title(s): \_\_\_\_\_  
 Partner  Limited  General  
 Attorney in Fact  
 Trustee  
 Guardian or Conservator  
 Other: \_\_\_\_\_

RIGHT THUMBPRINT  
OF SIGNER

Top of thumb here

Signer is Representing:

Western Surety Company

Signer's Name: \_\_\_\_\_

- Individual  
 Corporate Officer — Title(s): \_\_\_\_\_  
 Partner  Limited  General  
 Attorney in Fact  
 Trustee  
 Guardian or Conservator  
 Other: \_\_\_\_\_

RIGHT THUMBPRINT  
OF SIGNER

Top of thumb here

Signer is Representing:

# Western Surety Company

## POWER OF ATTORNEY APPOINTING INDIVIDUAL ATTORNEY-IN-FACT

Know All Men By These Presents, That WESTERN SURETY COMPANY, a South Dakota corporation, is a duly organized and existing corporation having its principal office in the City of Sioux Falls, and State of South Dakota, and that it does by virtue of the signature and seal herein affixed hereby make, constitute and appoint

**Daniel P Dole, John T Dole, Robert P Dole, Adam Dole, Michael Dole, Patti Ewert, Individually**

of Bonita, CA, its true and lawful Attorney(s)-in-Fact with full power and authority hereby conferred to sign, seal and execute for and on its behalf bonds, undertakings and other obligatory instruments of similar nature

**- In Unlimited Amounts -**

and to bind it thereby as fully and to the same extent as if such instruments were signed by a duly authorized officer of the corporation and all the acts of said Attorney, pursuant to the authority hereby given, are hereby ratified and confirmed.

This Power of Attorney is made and executed pursuant to and by authority of the Authorizing By-Laws and Resolutions printed at the bottom of this page, duly adopted, as indicated, by the shareholders of the corporation.

In Witness Whereof, WESTERN SURETY COMPANY has caused these presents to be signed by its Vice President and its corporate seal to be hereto affixed on this 16th day of January, 2024.



WESTERN SURETY COMPANY

*Larry Kasten*

Larry Kasten, Vice President

State of South Dakota }  
County of Minnehaha } ss

On this 16th day of January, 2024, before me personally came Larry Kasten, to me known, who, being by me duly sworn, did depose and say: that he resides in the City of Sioux Falls, State of South Dakota; that he is a Vice President of WESTERN SURETY COMPANY described in and which executed the above instrument; that he knows the seal of said corporation; that the seal affixed to the said instrument is such corporate seal; that it was so affixed pursuant to authority given by the Board of Directors of said corporation and that he signed his name thereto pursuant to like authority, and acknowledges same to be the act and deed of said corporation.

My commission expires

March 2, 2026



*M. Bent*

M. Bent, Notary Public

### CERTIFICATE

I, Paula Kolsrud, Assistant Secretary of WESTERN SURETY COMPANY do hereby certify that the Power of Attorney hereinabove set forth is still in force, and further certify that the By-Law and Resolutions of the corporation printed below this certificate are still in force. In testimony whereof I have hereunto subscribed my name and affixed the seal of the said corporation this 26 day of February, 2024.



WESTERN SURETY COMPANY

*Paula Kolsrud*

Paula Kolsrud, Assistant Secretary

### Authorizing By-Laws and Resolutions

#### ADOPTED BY THE SHAREHOLDERS OF WESTERN SURETY COMPANY

This Power of Attorney is made and executed pursuant to and by authority of the following By-Law duly adopted by the shareholders of the Company.

Section 7. All bonds, policies, undertakings, Powers of Attorney, or other obligations of the corporation shall be executed in the corporate name of the Company by the President, Secretary, and Assistant Secretary, Treasurer, or any Vice President, or by such other officers as the Board of Directors may authorize. The President, any Vice President, Secretary, any Assistant Secretary, or the Treasurer may appoint Attorneys in Fact or agents who shall have authority to issue bonds, policies, or undertakings in the name of the Company. The corporate seal is not necessary for the validity of any bonds, policies, undertakings, Powers of Attorney or other obligations of the corporation. The signature of any such officer and the corporate seal may be printed by facsimile.

This Power of Attorney is signed by Larry Kasten, Vice President, who has been authorized pursuant to the above Bylaw to execute power of attorneys on behalf of Western Surety Company.

This Power of Attorney may be signed by digital signature and sealed by a digital or otherwise electronic-formatted corporate seal under and by the authority of the following Resolution adopted by the Board of Directors of the Company by unanimous written consent dated the 27<sup>th</sup> day of April, 2022:

“RESOLVED: That it is in the best interest of the Company to periodically ratify and confirm any corporate documents signed by digital signatures and to ratify and confirm the use of a digital or otherwise electronic-formatted corporate seal, each to be considered the act and deed of the Company.”

Go to [www.cnasurety.com](http://www.cnasurety.com) > Owner / Obligor Services > Validate Bond Coverage, if you want to verify bond authenticity.

**CONTRACTOR'S CERTIFICATION OF PENDING ACTIONS**

As part of its bid or proposal (Non-Price Proposal in the case of Design-Build contracts), the Bidder shall provide to the City a list of all instances within the past 10 years where a complaint was filed or pending against the Bidder in a legal or administrative proceeding alleging that Bidder discriminated against its employees, subcontractors, vendors or suppliers, and a description of the status or resolution of that complaint, including any remedial action taken.

CHECK ONE BOX ONLY.

- The undersigned certifies that within the past 10 years the Bidder has NOT been the subject of a complaint or pending action in a legal administrative proceeding alleging that Bidder discriminated against its employees, subcontractors, vendors or suppliers.
  
- The undersigned certifies that within the past 10 years the Bidder has been the subject of a complaint or pending action in a legal administrative proceeding alleging that Bidder discriminated against its employees, subcontractors, vendors or suppliers. A description of the status or resolution of that complaint, including any remedial action taken and the applicable dates is as follows:

DATE OF CLAIM	LOCATION	DESCRIPTION OF CLAIM	LITIGATION (Y/N)	STATUS	RESOLUTION/REMEDIAL ACTION TAKEN

Contractor Name: S.C. Valley Engineering, Inc.

Certified By Sam Wathen Title President  
Name  
  
Signature Date 02/28/2024

**USE ADDITIONAL FORMS AS NECESSARY**



## SUBCONTRACTORS FOR ALTERNATES

**\*\*\* FOR USE WHEN LISTING SUBCONTRACTORS FOR ALTERNATES ONLY \*\*\***  
**(Use Additional Sheets As Needed)**

IDENTIFY ALTERNATE <small>(example: Deductive Alternate B)</small> <small>Only one Alternate and Sub per line</small>	SUBCONTRACTOR NAME, LOCATION, PHONE & EMAIL	SUBCONTRACTOR'S CA LICENSE NUMBER	SUBCONTRACTOR'S DIR REGISTRATION NUMBER	IS SUBCONTRACTOR CONSTRUCTOR, DESIGNER, OR SUPPLIER	TYPE OF WORK	DOLLAR VALUE OF THE ALTERNATE SUBCONTRACT <small>(Negative if Deductive)</small>
Additive Alternate A	Name: <u>Sealright Paving, Inc.</u> Address: <u>9053 Olive Drive</u> City: <u>Spring Valley</u> State: <u>CA</u> Zip: <u>91977</u> Phone: <u>(619) 465-7411</u> Email: <u>estimating@sealrightpavinginc.com</u>	364113	1000039542	Constructor	Asphalt / Cold Milling Work	\$882,898.96
Additive Alternate A	Name: <u>Sael Constructio Corporation</u> Address: <u>2173 Camino Del Este #6115</u> City: <u>San Diego</u> State: <u>CA</u> Zip: <u>92108</u> Phone: <u>(949) 690-7303</u> Email: <u>eng.ahmed.sail@gmail.com</u>	1086338	PW-LR- 1001008526	Constructor	Concrete Work	\$25,325.00
	Name: _____ Address: _____ City: _____ State: _____ Zip: _____ Phone: _____ Email: _____					
	Name: _____ Address: _____ City: _____ State: _____ Zip: _____ Phone: _____ Email: _____					

**SUBCONTRACTORS FOR ALTERNATE ITEMS ARE NOT CONSIDERED IN THE CALCULATION TOWARD ACHIEVING  
 SLBE/ELBE PARTICIPATION GOALS**

## Mandatory Disclosure of Business Interests Form

### BIDDER/PROPOSER INFORMATION

Legal Name		DBA	
S.C. Valley Engineering, Inc.			
Street Address	City	State	Zip
656 Front Street	El Cajon	CA	92020
Contact Person, Title		Phone	Fax
Sam Wathen, President		619-444-2366	619-444-2333

Provide the name, identity, and precise nature of the interest\* of all persons who are directly or indirectly involved\*\* in this proposed transaction (SDMC § 21.0103).

\* The precise nature of the interest includes:

- the percentage ownership interest in a party to the transaction,
- the percentage ownership interest in any firm, corporation, or partnership that will receive funds from the transaction, the value of any financial interest in the transaction,
- any contingent interest in the transaction and the value of such interest should the contingency be satisfied, and any philanthropic, scientific, artistic, or property interest in the transaction.

\*\* Directly or indirectly involved means pursuing the transaction by:

- communicating or negotiating with City officers or employees,
- submitting or preparing applications, bids, proposals or other documents for purposes of contracting with the City,
- or directing or supervising the actions of persons engaged in the above activity.

Name	Title/Position
Sam Wathen	President
City and State of Residence	Employer (if different than Bidder/Proposer)
El Cajon, CA	
Interest in the transaction	
51% Ownership of S.C. Valley	

Name	Title/Position
Colleen Wathen	CFO
City and State of Residence	Employer (if different than Bidder/Proposer)
El Cajon, CA	
Interest in the transaction	
49% Ownership of S.C. Valley	

### \* Use Additional Pages if Necessary \*

Under penalty of perjury under the laws of the State of California, I certify that I am responsible for the completeness and accuracy of the responses contained herein, and that all information provided is true, full and complete to the best of my knowledge and belief. I agree to provide written notice to the Mayor or Designee within five (5) business days if, at any time, I learn that any portion of this Mandatory Disclosure of Business Interests Form requires an updated response. Failure to timely provide the Mayor or Designee with written notice is grounds for Contract termination.

Sam Wathen, President

02/28/2024

Print Name, Title

Signature

Date

**Failure to sign and submit this form with the bid/proposal shall make the bid/proposal non-responsive. In the case of an informal solicitation, the contract will not be awarded unless a signed and completed Mandatory Disclosure of Business Interests Form is submitted.**

**DEBARMENT AND SUSPENSION CERTIFICATION**  
**PRIME CONTRACTOR**  
**FAILURE TO COMPLETE AND SUBMIT AT TIME OF BID SHALL RENDER BID NON-RESPONSIVE**

EFFECT OF DEBARMENT OR SUSPENSION
To promote integrity in the City's contracting processes and to protect the public interest, the City shall only enter into contracts with responsible-bidders and contractors. In accordance with San Diego Municipal Code §22.0814 (a): <i>Bidders</i> and <i>contractors</i> who have been <i>debarred</i> or <i>suspended</i> are excluded from submitting bids, submitting responses to requests for proposal or qualifications, receiving <i>contract</i> awards, executing <i>contracts</i> , participating as a <i>subcontractor</i> , <i>employee</i> , <i>agent</i> or <i>representative</i> of another <i>person</i> contracting with the City.

As part of its bid or proposal (Non-Price Proposal in the case of Design-Build contracts), the Bidder shall provide to the City a list of Names of the Principal Individual owner(s).

The names of all persons interested in the foregoing proposal as Principals are as follows:

NAME	TITLE
Sam Wathen	President
Colleen Wathen	CFO

**IMPORTANT NOTICE:** If Bidder or other interested person is a corporation, state secretary, treasurer, and manager thereof; if a co-partnership, state true name of firm, also names of all individual co-partners composing firm; if Bidder or other interested person is an individual, state first and last names in full.

The Bidder, under penalty of perjury, certifies that, except as noted below, he/she or any person associated therewith in the capacity of owner, partner, director, officer, manager:

- Is not currently under suspension, debarment, voluntary exclusion, or determination of ineligibility by any Federal, State or local agency;
- has not been suspended, debarred, voluntarily excluded or determined ineligible by any Federal, State or local agency within the past 3 years;
- does not have a proposed debarment pending; and
- has not been indicted, convicted, or had a civil judgment rendered against it by a court of competent jurisdiction in any matter involving fraud or official misconduct within the past 3 years.

If there are any exceptions to this certification, insert the exceptions in the following space.

Exceptions will be considered in determining bidder responsibility. For any exception noted above, indicate below to whom it applies, initiating agency, and dates of action.

Contractor Name: S.C. Valley Engineering, Inc.

Certified By Sam Wathen Title President

  
 Name  
 Signature

Date 02/28/2024

**NOTE:** Providing false information may result in criminal prosecution or administrative sanctions.

**DEBARMENT AND SUSPENSION CERTIFICATION  
SUBCONTRACTORS, SUPPLIERS AND MANUFACTURERS**

**\*TO BE COMPLETED BY BIDDER\***

**FAILURE TO COMPLETE AND SUBMIT AT TIME OF BID SHALL RENDER BID NON-RESPONSIVE**

Names of the Principal individual owner(s)

As part of its bid or proposal (Non-Price Proposal in the case of Design-Build contracts), the Bidder shall provide to the City a list of Names of the Principal Individual owner(s) for their subcontractor/supplier/manufacturers.

Please indicate if principal owner is serving in the capacity of **subcontractor, supplier, and/or manufacturer:**

SUBCONTRACTOR                       SUPPLIER                       MANUFACTURER

NAME	TITLE
Vic Salazar Communications - Vic Salazar	President
Sael Constructio Corporation - Ahmed Hussein	President/Owner
CODE 3 Media - Chris Marquart	President
Soclaris Contracting - Sonny Rosenal	President

SUBCONTRACTOR                       SUPPLIER                       MANUFACTURER

NAME	TITLE
R&C Structures - Kelly Santar	President
R&C Structures - Pete Santar	Vice President
National Coating and Lining - Anton Anstett	President
Southwest Signal Service - Ryan Clark	President

SUBCONTRACTOR                       SUPPLIER                       MANUFACTURER

NAME	TITLE
Loveless Linton - Rebekah Loveless	President
SealRight Paving, Inc. - Frank Vasquez	President
Easy Flow - Adam Wilson	President
Statewide Stripes, Inc. - Dave Brillhante	President

SUBCONTRACTOR                       SUPPLIER                       MANUFACTURER

NAME	TITLE
Western Gardens Landscaping, Inc. - Greg Vasilieff	President
Western Gardens Landscaping, Inc. - Robert Vasilieff	Vice President
Western Gardens Landscaping, Inc. - Marie Vasilieff	CFO

Contractor Name: S.C. Valley Engineering, Inc.

Certified By Sam Wathen Title President

  
 Name  
 Signature

Date 02/28/2024

**\*USE ADDITIONAL FORMS AS NECESSARY\*\***

**DEBARMENT AND SUSPENSION CERTIFICATION  
 SUBCONTRACTORS, SUPPLIERS AND MANUFACTURERS  
 \*TO BE COMPLETED BY BIDDER\*  
 FAILURE TO COMPLETE AND SUBMIT AT TIME OF BID SHALL RENDER BID NON-RESPONSIVE**

Names of the Principal individual owner(s)

As part of its bid or proposal (Non-Price Proposal in the case of Design-Build contracts), the Bidder shall provide to the City a list of Names of the Principal Individual owner(s) for their subcontractor/supplier/manufacturers.

Please indicate if principal owner is serving in the capacity of **subcontractor**, **supplier**, and/or **manufacturer**:

SUBCONTRACTOR                       SUPPLIER                       MANUFACTURER

NAME	TITLE
Nu-Line Technologies, LLC - Salvador "Buddy" Aquino	Partner
Nu-Line Technologies, LLC - Dominic & Julie Burtech	Partner
Nu-Line Technologies, LLC - Frank Durazo	Partner

SUBCONTRACTOR                       SUPPLIER                       MANUFACTURER

NAME	TITLE

SUBCONTRACTOR                       SUPPLIER                       MANUFACTURER

NAME	TITLE

SUBCONTRACTOR                       SUPPLIER                       MANUFACTURER

NAME	TITLE

Contractor Name: S.C. Valley Engineering, Inc.

Certified By Sam Wathen Title President

  
 Name \_\_\_\_\_ Date 02/28/2024  
 Signature \_\_\_\_\_

**\*USE ADDITIONAL FORMS AS NECESSARY\*\***

## Bid Results

### Bidder Details

**Vendor Name** S.C. Valley Engineering, Inc.  
**Address** 656 Front St.  
El Cajon, California 92020  
United States  
**Respondee** Buzz Birney  
**Respondee Title** Estimator  
**Phone** 619-444-2366  
**Email** Buzz@scvalleyinc.com  
**Vendor Type** MBE, CADIR  
**License #** 624559  
**CADIR** 1000020727

### Bid Detail

**Bid Format** Electronic  
**Submitted** 02/28/2024 12:53 PM (PST)  
**Delivery Method**  
**Bid Responsive**  
**Bid Status** Submitted  
**Confirmation #** 366196

### Respondee Comment

### Buyer Comment

### Attachments

File Title	File Name	File Type
Pending Actions Signed.pdf	Pending Actions Signed.pdf	Contractor's Certification of Pending Actions
Alternates.pdf	Alternates.pdf	Subcontractor Listing - Alternate Items
Business Interests Signed.pdf	Business Interests Signed.pdf	Mandatory Disclosure of Business Interests Form
Debarment Prime Signed.pdf	Debarment Prime Signed.pdf	Prime Contractor - Debarment and Suspension Certification
Debarment Sub -Signed.pdf	Debarment Sub -Signed.pdf	Subcontractor - Debarment and Suspension Certification
Bid Bond Signed.pdf	Bid Bond Signed.pdf	Bid Bond

## Subcontractors

Showing 13 Subcontractors

Name & Address	Desc	License Num	CADIR	Amount	Type
<b>CODE 3 Media</b> 1275 Ocean Breeze St San Marcos, California 92078	Constructor -Video Pre-Existing	00000	1000055028	\$10,080.00	ELBE, Local
<b>Easy Flow</b> 12530 Stowe Dr Poway, California 92064	Constructor - Lateral Sewer Rehab Dig & Line	960845	1000010925	\$163,200.00	CADIR, SLBE, CAU, MALE, Local
<b>Loveless Linton, Inc. Archaeological,</b> 1421 W. Lewis St San Diego, California 92103	Constructor - Archeo/Paleo/ and Native American Monitoring and Mitigation	00000	1000047263	\$208,831.75	DBE, SDB, CADIR, MBE, NAT, MALE, SLBE, Local
<b>National Coating &amp; Lining</b> 26713 Madison Ave Murrieta, California 92532	Constructor - Manholes Rehab and Linings	886430	1000013795	\$16,370.00	
<b>Nu-Line Technologies, LLC</b> 1325 Pipeline Dr Vista, California 92081	Constructor - Sewer Rehab	997520	1000003808	\$258,601.00	CADIR, MBE, WBE, FEM, Local
<b>R &amp; C Structures, Inc</b> 1615 La Mirada Dr San Diego, California 92078	Constructor - Manholes	425215	1000004446	\$866,491.00	WBE, SDB, Local
<b>Sael Construction Corporation</b> 2173 Camino Del Este apt6115 San Diego, California 92108	Constructor - Curb Ramps, Concrete Pavement, Concrete Work	1086338	PW-LR-1001008526	\$666,791.00	CADIR, ELBE, Local
<b>SealRight Paving, Inc.</b> 9053 Olive Dr. Spring Valley, California 91977	Constructor - Asphalt /Cold Milling Work	364113	1000039542	\$987,064.17	MBE, CADIR, DBE, MALE, LAT, PQUAL, SLBE, Local
<b>Soclaris Contracting</b> 7437 Lowell Ct. La Mesa, California 91942	Constructor - Hazard Materials transport and disposal	793838	1000011964	\$135,000.00	DVBE, CADIR, MALE, SDVSB, CAU, ELBE, Local
<b>Southwest Signal Services</b> P.O. Box 1297 El Cajon, California 92022	Constructor - Traffic Loops, Temp Detection System, Pedestrian Push Button	451115	1000004265	\$347,580.00	Local
<b>Statewide Stripes Inc.</b> PO Box 600710 San Diego, California 92160	Constructor - Striping, Crosswalks, Traffic Signs Work	788286	1000001334	\$199,908.75	CADIR, DBE, Local
<b>Vic Salazar Communications</b> 5205 Kearny Villa Way Suite 107 San Diego, California 92123	Constructor - Community Liaison Services	00000	PW-LR-1000364796	\$183,000.00	DBE, MBE, CADIR, ELBE, MALE, LAT, Local
<b>Western Gardens Landscaping, Inc.</b> 4616 Pannonia Rd. Carlsbad, California 92008	Constructor - Landscaping Services/ Hydroseed, Repair/Replace existing Irrigation	662550	1000004289	\$97,144.00	CADIR, SLBE, Local



## Line Items

Discount Terms No Discount

Item #	Item Code	Type	Item Description	UOM	QTY	Unit Price	Line Total	Response	Comment
Main Bid Sewer							\$12,415,000.00		
1	524126		Bonds (Payment and Performance)	LS	1	\$61,750.00	\$61,750.00	Yes	
2	237110		Sewage Bypass and Pumping Plan (Diversion Plan)	LS	1	\$150,000.00	\$150,000.00	Yes	
3	541820		Exclusive Community Liaison Services	LS	1	\$63,000.00	\$63,000.00	Yes	
4	541690		Archaeological and Native American Monitoring Program	LF	8700	\$13.00	\$113,100.00	Yes	
5	541690		Paleontological Monitoring Program	LF	9017	\$7.00	\$63,119.00	Yes	
6	541690		Suspension of Work - Resources	DAY	4	\$1,520.00	\$6,080.00	Yes	
7	541690		Archaeological and Native American Mitigation and Curation (EOC Type I)	AL	1	\$7,500.00	\$7,500.00	Yes	
8	541690		Paleontological Mitigation and Excavation	CY	9291	\$2.00	\$18,582.00	Yes	
9	237110		Mobilization	LS	1	\$372,149.00	\$372,149.00	Yes	
10			Field Orders (EOC Type II)	AL	1	\$990,000.00	\$990,000.00	Yes	
11	238910		Clearing and Grubbing	LS	1	\$14,061.00	\$14,061.00	Yes	
12	237310		Excavate and Export (Scheduled, 10 Inch)	CY	14	\$550.00	\$7,700.00	Yes	
13	237310		Excavate and Export (Unscheduled, 10 Inch)	CY	6	\$605.00	\$3,630.00	Yes	
14	237310		Class 2 Aggregate Base (Scheduled, 5 Inch)	TON	13	\$630.00	\$8,190.00	Yes	
15	237310		Class 2 Aggregate Base (Unscheduled, 5 Inch)	TON	6	\$680.00	\$4,080.00	Yes	
16	237310		Asphalt Concrete Base (Scheduled, 5 Inch)	TON	14	\$985.00	\$13,790.00	Yes	
17	237310		Asphalt Concrete Base (Unscheduled, 5 Inch)	TON	6	\$1,100.00	\$6,600.00	Yes	
18	237310		Asphalt Concrete Overlay (2 inch)	TON	215	\$565.00	\$121,475.00	Yes	
19	237310		Asphalt Concrete Overlay (3 inch)	TON	190	\$430.00	\$81,700.00	Yes	
20	238140		Brick Masonry Retaining Wall	SF	10	\$550.00	\$5,500.00	Yes	
21	237310		Historical and Contractor Date Stamps and Impressions	EA	11	\$210.00	\$2,310.00	Yes	
22	237310		Cross Gutter	SF	11385	\$20.00	\$227,700.00	Yes	
23	237310		Additional Curb	LF	255	\$47.00	\$11,985.00	Yes	
24	237310		Additional Sidewalk	SF	1020	\$14.00	\$14,280.00	Yes	
25	237310		Curb Ramp (Type C1) with Stainless Steel Detectable Warning Tiles	EA	2	\$6,720.00	\$13,440.00	Yes	
26	237310		Curb Ramp (Type C1) with Detectable Warning Tiles	EA	3	\$6,510.00	\$19,530.00	Yes	
27	237310		Curb Ramp (Type C2) with Stainless Steel Detectable Warning Tiles	EA	10	\$6,930.00	\$69,300.00	Yes	
28	237310		Curb Ramp Modified (Type C1, Per 42048-59-D to 42048-62-D, 42048-64-D to 42048-67-D, 42048-72-D to 42048-77-D, 42048-79-D to 42048-80-D, 42048-82-D to 42048-83-D) with Detectable Warning Tiles	EA	18	\$7,455.00	\$134,190.00	Yes	
29	237310		Curb Ramp Modified (Type C1, Per 42048-63-D, 42048-68-D, 42048-71-D, 42048-78-D, 42048-81-D, 42048-85-D) with Stainless Steel Detectable Warning Tiles	EA	6	\$7,455.00	\$44,730.00	Yes	
30	237310		Curb Ramp Modified (Type A, Per 42048-55-D to 42048-56-D) with Stainless Steel Detectable Warning Tiles	EA	2	\$7,455.00	\$14,910.00	Yes	
31	237310		Curb Ramp Modified (Type C2, Per 42048-57-D to 42048-58-D, 42048-69-D, 42048-70-D, 42048-84-D) with Stainless Steel Detectable Warning Tiles	EA	4	\$7,770.00	\$31,080.00	Yes	
32	237110		Phased Paving	EA	7	\$5,950.00	\$41,650.00	Yes	
33	237110		Abandon and Fill Existing Sewer Main (8 Inch) Outside of the Trench Limit	LF	6287	\$10.00	\$62,870.00	Yes	
34	237110		Abandon and Fill Existing Sewer Main (15 Inch) Outside of the Trench Limit	LF	1215	\$12.00	\$14,580.00	Yes	
35	237110		Abandon Existing Manhole Outside of the Trench Limit	EA	17	\$2,700.00	\$45,900.00	Yes	
36	237110		Additional Bedding	CY	451	\$107.00	\$48,257.00	Yes	
37	237110		Sewer Main (8 Inch)	LF	10343	\$190.00	\$1,965,170.00	Yes	
38	237110		Sewer Main (10 Inch)	LF	356	\$490.00	\$174,440.00	Yes	
39	237110		Sewer Main (8 Inch, SDR-26)	LF	2515	\$250.00	\$628,750.00	Yes	
40	237110		Sewer Main (8 Inch, SDR-18)	LF	1524	\$480.00	\$731,520.00	Yes	
41	237110		Sewer Main (8 Inch, SDR-14)	LF	525	\$1,050.00	\$551,250.00	Yes	
42	237110		Sewer Main (10 Inch, SDR-26)	LF	441	\$410.00	\$180,810.00	Yes	
43	237110		Engineered Trench Shoring	LS	1	\$191,355.00	\$191,355.00	Yes	
44	237310		Temporary Resurfacing	TON	683	\$220.00	\$150,260.00	Yes	
45	237110		Imported Trench Backfill	TON	3738	\$75.00	\$280,350.00	Yes	
46	237110		Manhole (4 ft x 3 ft)	EA	93	\$12,899.00	\$1,199,607.00	Yes	
47	237110		Manhole (5 ft x 3 ft)	EA	1	\$36,209.00	\$36,209.00	Yes	
48	237110		Manhole (Lined 8 ft), (per 42048-87-D & 42048-88-D)	EA	2	\$188,114.00	\$376,228.00	Yes	
49	237110		Connection to Existing Manhole and Rechanneling	EA	1	\$14,066.00	\$14,066.00	Yes	

Item #	Item Code	Type	Item Description	UOM	QTY	Unit Price	Line Total	Response	Comment
50	237110		Sewer Lateral and Cleanout (4 Inch, Street)	EA	238	\$4,050.00	\$963,900.00	Yes	
51	237110		Sewer Lateral and Cleanout (6 Inch, Street)	EA	6	\$5,300.00	\$31,800.00	Yes	
52	237110		Sewer Lateral and Cleanout (6 Inch, Special Strength SDR-26, Street)	EA	2	\$7,450.00	\$14,900.00	Yes	
53	237110		Sewer Lateral and Cleanout (8 Inch, Special Strength SDR-26, Street)	EA	1	\$13,385.00	\$13,385.00	Yes	
54	237110		Sewer Lateral and Cleanout (4 Inch, Special Strength SDR 26, Street)	EA	36	\$4,050.00	\$145,800.00	Yes	
55	237110		Sewer Lateral and Cleanout (4 Inch, Special Strength SDR 18, Street)	EA	32	\$4,600.00	\$147,200.00	Yes	
56	237110		Sewer Lateral and Cleanout (4 Inch, Special Strength SDR 14, Street)	EA	7	\$5,085.00	\$35,595.00	Yes	
57	237110		Cleaning and Video Inspection of Existing Pipelines and Culverts	LF	3517	\$6.00	\$21,102.00	Yes	
58	237110		Video Inspection of Pipelines and Culverts for Acceptance	LF	25363	\$4.00	\$101,452.00	Yes	
59	237310		Removal and Replacement of Existing Paint Striping	LS	1	\$25,725.00	\$25,725.00	Yes	
60	237310		Removal and Replacement of Existing Thermoplastic Striping and Markings	LS	1	\$33,915.00	\$33,915.00	Yes	
61	237310		Continental Crosswalks	SF	10595	\$5.00	\$52,975.00	Yes	
62	238990		Video Recording of Existing Conditions	LS	1	\$6,048.00	\$6,048.00	Yes	
63	237310		Adjust Existing Manhole Frame and Cover to Grade	EA	1	\$1,085.00	\$1,085.00	Yes	
64	237310		Adjust Existing Gate Valve Frame and Cover to Grade	EA	23	\$420.00	\$9,660.00	Yes	
65	237310		Adjust Existing Survey Monument to Grade	EA	10	\$1,125.00	\$11,250.00	Yes	
66	237310		Traffic Signal Loop and Appurtenance Replacement (Type E)	EA	29	\$756.00	\$21,924.00	Yes	
67	237310		Traffic Signal Loop and Appurtenance Replacement (Modified Type E)	EA	16	\$788.00	\$12,608.00	Yes	
68	237310		Cold Milling Full Width (2 inch)	SF	17776	\$2.00	\$35,552.00	Yes	
69	237310		Cold Milling Full Width (3 inch)	SF	10445	\$2.00	\$20,890.00	Yes	
70	237110		Point Repair for Existing Sewer Main (8 Inch)	EA	1	\$11,384.00	\$11,384.00	Yes	
71	237110		Additional Point Repair for Existing Sewer Main (8 Inch)	LF	12	\$949.00	\$11,388.00	Yes	
72	237110		Rehabilitate Sewer Main (8 Inch)	LF	3517	\$55.00	\$193,435.00	Yes	
73	237110		Service Lateral Connection	EA	55	\$2,080.00	\$114,400.00	Yes	
74	237110		Rehabilitate Existing Manhole	EA	10	\$4,065.00	\$40,650.00	Yes	
75	237110		Service Lateral Rehabilitation with Cleanout	EA	51	\$3,360.00	\$171,360.00	Yes	
76	541330		Traffic Control and Working Drawings	LS	1	\$207,000.00	\$207,000.00	Yes	
77	238210		Temporary Detection System	EA	5	\$62,055.00	\$310,275.00	Yes	
78	238210		Remove and Reinstall Traffic Signs	EA	22	\$790.00	\$17,380.00	Yes	
79	237310		Pedestrian Barricade (Type A)	EA	2	\$1,575.00	\$3,150.00	Yes	
80	238210		Pedestrian Push Button and Foundation	EA	3	\$4,095.00	\$12,285.00	Yes	
81	238210		Traffic Detector Loop Stub	EA	5	\$1,575.00	\$7,875.00	Yes	
82	561730		Install Bark Mulch (3 inch Depth)	CY	6	\$470.00	\$2,820.00	Yes	
83	561730		Weed Eradication	SF	3980	\$5.00	\$19,900.00	Yes	
84	561730		Repair/Replace Existing Irrigation Damaged by Construction	EA	1	\$26,250.00	\$26,250.00	Yes	
85	561730		Perform Agricultural Soils Tests and Percolation Tests	EA	3	\$525.00	\$1,575.00	Yes	
86	561730		Plant Establishment Period (90 days)	EA	1	\$3,150.00	\$3,150.00	Yes	
87	561730		Plant Establishment Period (120 days)	EA	2	\$21,000.00	\$42,000.00	Yes	
88	561730		Hydro Seed	SF	1936	\$5.00	\$9,680.00	Yes	
89	561730		Shrub (5 Gallon)	EA	16	\$84.00	\$1,344.00	Yes	
90	541330		Biological Monitoring and Reporting	LS	1	\$11,100.00	\$11,100.00	Yes	
91	541330		WPCP Development	LS	1	\$840.00	\$840.00	Yes	
92	237310		WPCP Implementation	LS	1	\$100,260.00	\$100,260.00	Yes	
<b>Main Bid Water</b>							<b>\$4,400,008.00</b>		
93	524126		Bonds (Payment and Performance)	LS	1	\$27,025.00	\$27,025.00	Yes	
94	541820		Exclusive Community Liaison Services	LS	1	\$129,150.00	\$129,150.00	Yes	
95	541690		Archaeological and Native American Monitoring Program	LF	3000	\$5.00	\$15,000.00	Yes	
96	541690		Suspension of Work - Resources	DAY	1	\$2,217.00	\$2,217.00	Yes	
97	541690		Archaeological and Native American Mitigation and Curation (EOC Type I)	AL	1	\$2,600.00	\$2,600.00	Yes	
98	237110		Mobilization	LS	1	\$165,471.00	\$165,471.00	Yes	

Item #	Item Code	Type	Item Description	UOM	QTY	Unit Price	Line Total	Response	Comment
99			Field Orders (EOC Type II)	AL	1	\$355,000.00	\$355,000.00	Yes	
100	237310		Excavate and Export (Scheduled, 10 Inch)	CY	113	\$305.00	\$34,465.00	Yes	
101	237310		Excavate and Export (Unscheduled, 10 Inch)	CY	46	\$175.00	\$8,050.00	Yes	
102	237310		Class 2 Aggregate Base (Scheduled, 5 Inch)	TON	100	\$115.00	\$11,500.00	Yes	
103	237310		Class 2 Aggregate Base (Unscheduled, 5 Inch)	TON	40	\$165.00	\$6,600.00	Yes	
104	237310		Asphalt Concrete Base (Scheduled, 5 Inch)	TON	111	\$325.00	\$36,075.00	Yes	
105	237310		Asphalt Concrete Base (Unscheduled, 5 Inch)	TON	45	\$320.00	\$14,400.00	Yes	
106	237310		Historical and Contractor Date Stamps and Impressions	EA	3	\$210.00	\$630.00	Yes	
107	237310		Additional Curb	LF	40	\$70.00	\$2,800.00	Yes	
108	237310		Additional Sidewalk	SF	160	\$17.00	\$2,720.00	Yes	
109	237310		Cross Gutter	SF	1509	\$20.00	\$30,180.00	Yes	
110	237310		Curb Ramp (Type A) with Stainless Steel Detectable Warning Tiles	EA	2	\$6,720.00	\$13,440.00	Yes	
111	237310		Curb Ramp (Type C2) with Stainless Steel Detectable Warning Tiles	EA	6	\$6,930.00	\$41,580.00	Yes	
112	237110		Phased Paving	EA	3	\$5,950.00	\$17,850.00	Yes	
113	237110		Removal or Abandonment of Existing Water Facilities (Fire Hydrants)	EA	9	\$971.00	\$8,739.00	Yes	
114	237110		Abandon and Fill Existing Water Main Outside of the Trench Limit	LF	3007	\$9.00	\$27,063.00	Yes	
115	237110		Handling and Disposal of Non-friable Asbestos Material	LF	4883	\$42.00	\$205,086.00	Yes	
116	237110		Additional Bedding	CY	210	\$106.00	\$22,260.00	Yes	
117	237110		Water Main (8 Inch)	LF	801	\$160.00	\$128,160.00	Yes	
118	237110		Water Main (12 Inch)	LF	4421	\$220.00	\$972,620.00	Yes	
119	237110		Water Main (8 Inch, Class 305)	LF	2262	\$195.00	\$441,090.00	Yes	
120	237110		Water Main (12 Inch, Class 305)	LF	60	\$365.00	\$21,900.00	Yes	
121	237110		Gate Valve (8 Inch)	EA	9	\$3,415.00	\$30,735.00	Yes	
122	237110		Gate Valve (12 Inch)	EA	6	\$5,675.00	\$34,050.00	Yes	
123	237110		Fire Hydrant Assembly and Marker (6 Inch, 2-port)	EA	11	\$12,730.00	\$140,030.00	Yes	
124	237110		Fire Hydrant Assembly and Marker (6 Inch, 3-port)	EA	7	\$14,190.00	\$99,330.00	Yes	
125	237110		Water Service (1 Inch)	EA	147	\$4,470.00	\$657,090.00	Yes	
126	237110		Water Service (2 Inch)	EA	11	\$9,250.00	\$101,750.00	Yes	
127	237110		Blow-Off Valve Assembly (2 Inch, Class 305)	EA	1	\$6,550.00	\$6,550.00	Yes	
128	237110		Air and Vacuum (Air Release) Valve Assembly (2 Inch, Class 235)	EA	1	\$10,475.00	\$10,475.00	Yes	
129	237110		Air and Vacuum (Air Release) Valve Assembly (2 Inch, Class 305)	EA	1	\$10,590.00	\$10,590.00	Yes	
130	237110		Air and Vacuum (Air Release) Valve Assembly with Blow-Off (2 Inch, Class 305) per SDW 164	EA	1	\$10,285.00	\$10,285.00	Yes	
131	237310		Temporary Resurfacing	TON	502	\$220.00	\$110,440.00	Yes	
132	237110		Imported Trench Backfill	TON	1087	\$75.00	\$81,525.00	Yes	
133	237310		Removal and Replacement of Existing Paint Striping	LS	1	\$15,540.00	\$15,540.00	Yes	
134	237310		Removal and Replacement of Existing Thermoplastic Striping and Markings	LS	1	\$24,990.00	\$24,990.00	Yes	
135	237310		Continental Crosswalks	SF	5070	\$5.00	\$25,350.00	Yes	
136	238990		Video Recording of Existing Conditions	LS	1	\$4,538.00	\$4,538.00	Yes	
137	237310		Additional Pavement Removal and Disposal	CY	60	\$200.00	\$12,000.00	Yes	
138	237310		Adjust Existing Manhole Frame and Cover to Grade	EA	16	\$1,085.00	\$17,360.00	Yes	
139	541330		Traffic Control and Working Drawings	LS	1	\$86,000.00	\$86,000.00	Yes	
140	238210		Remove and Reinstall Traffic Signs	EA	4	\$788.00	\$3,152.00	Yes	
141	237310		Protective Railing at Curb Ramps	EA	4	\$1,995.00	\$7,980.00	Yes	
142	541330		Biological Monitoring and Reporting	LS	1	\$10,647.00	\$10,647.00	Yes	
143	237110		Pavement Restoration for Final Connection	SF	1900	\$30.00	\$57,000.00	Yes	
144	541330		WPCP Development	LS	1	\$840.00	\$840.00	Yes	
145	237310		WPCP Implementation	LS	1	\$98,090.00	\$98,090.00	Yes	
<b>Additive Alternate A</b>							<b>\$1,099,992.00</b>		
146	237310		Excavate and Export (Scheduled, 10 Inch)	CY	25	\$312.00	\$7,800.00	Yes	
147	237310		Excavate and Export (Unscheduled, 10 Inch)	CY	10	\$481.00	\$4,810.00	Yes	

Item #	Item Code	Type	Item Description	UOM	QTY	Unit Price	Line Total	Response	Comment
148	237310		Class 2 Aggregate Base (Scheduled, 5 Inch)	TON	22	\$386.00	\$8,492.00	Yes	
149	237310		Class 2 Aggregate Base (Unscheduled, 5 Inch)	TON	9	\$587.00	\$5,283.00	Yes	
150	237310		Asphalt Concrete Overlay (2 inch)	TON	4163	\$159.00	\$661,917.00	Yes	
151	237310		Asphalt Concrete Base (Scheduled, 5 Inch)	TON	24	\$495.00	\$11,880.00	Yes	
152	237310		Asphalt Concrete Base (Unscheduled, 5 Inch)	TON	10	\$682.00	\$6,820.00	Yes	
153	238910		Concrete Pavement (7 Inch Thick)	CY	21	\$578.00	\$12,138.00	Yes	
154	237310		Cross Gutter	SF	725	\$20.00	\$14,500.00	Yes	
155	237310		Cold Milling Full Width (2 inch)	SF	344540	\$1.00	\$344,540.00	Yes	
156	237310		Adjust Existing Manhole Frame and Cover to Grade	EA	2	\$578.00	\$1,156.00	Yes	
157	237310		Adjust Existing Gate Valve Frame and Cover to Grade	EA	66	\$285.00	\$18,810.00	Yes	
158	237310		Adjust Existing Survey Monument to Grade	EA	1	\$1,846.00	\$1,846.00	Yes	

## Line Item Subtotals

Section Title	Line Total
Main Bid Sewer	\$12,415,000.00
Main Bid Water	\$4,400,008.00
Additive Alternate A	\$1,099,992.00
<b>Grand Total</b>	<b>\$17,915,000.00</b>

**SUBCONTRACTOR LISTING (OTHER THAN FIRST TIER)**

Pursuant to California Senate Bill 96 and in accordance with the requirements of Labor Code sections 1771.1 and 1725.5, by submitting a bid or proposal to the City, Contractor is certifying that he or she has verified that all subcontractors used on this public work project are registered with the California Department of Industrial Relations (DIR). **The Bidder is to list below the name, address, license number, DIR registration number of any (known tiered subcontractor)** - who will perform work, labor, render services or specially fabricate and install a portion [type] of the work or improvement pursuant to the contract. **If none are known at this time, mark the table below with non-applicable (N/A).**

Prime Contractor Name: S.C. Valley Engineering, Inc.

NAME, ADDRESS AND TELEPHONE NUMBER OF SUBCONTRACTOR	CONSTRUCTOR OR DESIGNER	DIR REGISTRATION NUMBER	SUBCONTRACTOR LICENSE NUMBER	TYPE OF WORK
Name: _____ Address: _____ City: _____ State: _____ Zip: _____ Phone: _____ Email: _____	N/A			
Name: _____ Address: _____ City: _____ State: _____ Zip: _____ Phone: _____ Email: _____				
Name: _____ Address: _____ City: _____ State: _____ Zip: _____ Phone: _____ Email: _____				
Name: _____ Address: _____ City: _____ State: _____ Zip: _____ Phone: _____ Email: _____				

**\*\* USE ADDITIONAL FORMS AS NECESSARY \*\***