

APPENDIX D
Cudahy PER

Preliminary Engineering Report Cudahy Creek (Leisure Lagoon) Wetland Restoration

June 28, 2024

Presented To

**City of San Diego Engineering and Capital
Projects Department**

525 B Street, Suite 750, MS 908A
San Diego, CA 92101

Presented By

Rick

5620 Friars Road
San Diego, CA 92110

P +1-619-291-0707
F +1-619-291-4165
rickengineering.com



Prepared by:

Name: Brendan Hastie
Title: Principal

Date:
6/28/24

Reviewed by:

Name
Title

Date

Authorized by:

Name
Title

Date

Contents

1	INTRODUCTION.....	1
1.1	Project Overview.....	1
1.2	Project Location.....	4
1.3	Project Goals and Objectives.....	6
2	DATA COLLECTION AND EXISTING CHARACTERISTICS.....	7
2.1	Topography and Bathymetry.....	7
2.2	As-Built Drawings.....	7
2.3	Available GIS Data.....	8
2.4	Existing Conveyance Systems.....	8
3	EXISTING CONDITIONS.....	11
3.1	Hydrology.....	11
3.2	Hydraulics.....	12
3.3	Astronomical Tides.....	13
3.4	Measured Tides.....	13
3.4.1	What is Sea Level Rise?.....	14
3.4.2	Selected Sea Level Rise Scenarios.....	15
4	PRELIMINARY DESIGN.....	18
4.1	Project Components.....	19
4.1.1	Subtidal Channels.....	20
4.1.2	Subtidal Channel Stabilization.....	21
4.1.3	Salt Marsh Wetland.....	21
4.1.4	Berm Area.....	22
4.1.5	Oyster Bag Slope.....	22
4.1.6	Wetland Inundation and Water Quality.....	22
4.1.7	Fencing.....	23
4.2	Hydraulic Analysis Results.....	24
4.3	Preliminary Opinion of Probable Construction Cost.....	24
4.4	Preliminary Project Schedule.....	26
5	OTHER CONSIDERATIONS AS APPROPRIATE.....	27
5.1	Feasibility Analysis of Constructability.....	27
5.1.1	Construction Approach.....	27
5.1.2	Material Disposal/Re-use Options.....	27
5.1.3	Equipment Needs.....	28
5.1.4	Construction Access Points.....	28
5.1.5	Post-Construction Access.....	28
5.1.6	Maintenance Requirements.....	28
5.2	Risk Assessment.....	29

5.2.1 Land Ownership..... 30

5.2.2 Utilities..... 30

5.2.3 Existing Soil Data..... 30

5.2.4 Proximity to Neighbors 30

5.2.5 Environmental Windows..... 31

5.2.6 Water Quality Concerns 31

5.2.7 Competing Interests 32

5.2.8 Sensitive Habitat 32

5.2.9 Sea Level Rise 32

5.2.10 Permitting 34

5.3 Project Conflict Coordination and Evaluation 34

5.3.1 Wetland Restoration..... 35

5.4 Environmental Considerations and Permits 35

5.5 City Professional Standards and Mission Bay Masterplan Consistency..... 38

5.6 ADA and Title 24..... 40

6 REFERENCES..... 41

Tables

Table 1-1. Overall Project Goals and Relative Outcomes	6
Table 2-1. Summary of City of San Diego As-Built Drawings Reviewed.....	7
Table 2-2. SanGIS Data Inventory	8
Table 3-1. Key Rational Method Parameters Summary	12
Table 3-2. Summary of Hydrologic Data	12
Table 3-3. Existing Still Water Levels in Mission Bay (NOAA Station 9410230)	13
Table 3-4. Sea Level Rise Projections – San Diego, CA	16
Table 3-5. Sea Level Rise Projected Still Water Levels	17
Table 4-1. Existing and Proposed Habitat Areas.....	20
Table 4-2. Preliminary Opinion of Probable Construction Cost.....	25
Table 4-3. Preliminary Opinion of Probable Cost	25
Table 5-1. Change to Habitat Areas in Acres with 3.6 and 7.0 Feet of SLR.....	33
Table 5-2. Environmental Permit Requirements	35
Table 5-3. Inventory of Relevant Standards	38

Figures

Figure 1-1. Vicinity Map	2
Figure 1-2. Mission Bay Park PEIR Wetland Restoration Project Areas	3
Figure 1-3. Cudahy Creek Project Location.....	4
Figure 1-4. Aerial View of Mission Beach and False Bay - 1930 (www.sandiego.gov).....	5
Figure 2-1. Existing Storm Drain Outfalls.....	9
Figure 2-2. Existing Project Area, Outfalls, and Storm Drains	10
Figure 3-1. Measured Tides at Mission Bay and the Open Ocean.....	14
Figure 3-2. Sea Level Rise Projections – San Diego, CA.....	16
Figure 4-1. Preliminary Design Concept.....	19

Appendices

APPENDIX A. TECHNICAL SUPPORT DOCUMENTS

APPENDIX B. PRELIMINARY DRAWINGS

APPENDIX C. OPINION OF PROBABLE COSTS

APPENDIX D. PRELIMINARY PROJECT SCHEDULE

APPENDIX E. RISK ASSESSMENT TABLE

APPENDIX F. PROJECT GOALS AND OBJECTIVES TABLE

Acronyms/Abbreviations

Acronym/Abbreviation	Definition
BA	Biological Assessment
bgs	below ground surface
BMP	best management practice
BTR	Biological Technical Report
C	runoff coefficient
CADD	computer aided drafting and design
CCC	California Coastal Commission
CCS83	California Coordinate System of 1983
CDFW	California Department of Fish and Wildlife
CIP	capital improvement program
cfs	cubic feet per second
CWA	Clean Water Act
DEM	digital elevation model
ESA	Endangered Species Act
ft	foot, feet
GHG	greenhouse gas
GIS	geographic information system
HEC-RAS	Hydrologic Engineering Center River Analysis System
HOT	highest observed tide
I	intensity
LiDAR	Light Detection and Ranging
LOT	lowest observed tide
MHHW	mean higher-high water
MHW	mean high water
MLLW	mean lower-level water
MLW	mean low water
MSL	mean sea level
MS4	municipal separate storm sewer system
NAD 83	North American Datum of 1983
NAVD 88	North American Vertical datum of 1988
NGVD 29	Nation Geodetic Vertical Datum of 1929 (same as mean sea level)
NOAA	National Oceanic and Atmospheric Administration
NWP	nationwide permits

Acronym/Abbreviation	Definition
OPC	Ocean Protection Council
O&M	operations and maintenance
QA/QC	quality assurance/quality control
PER	Preliminary Engineering Report
PEIR	Program Environmental Impact Report
RCB	reinforced concrete box
RCP	reinforced concrete pipe
RCP	Representative Concentration Pathways
RGP	Regional General Permit
ROD	Record of Decision
ROW	right-of-way
RWQCB	Regional Water Quality Control Board
SANDAG	San Diego Association of Governments
SanGIS	San Diego Geographic Information Source
SLR	Sea Level Rise
SSURGO	Soil Survey Geographic Database
SWL	still water level
sq. mi.	square miles
Tc	time of concentration
USACE	U.S. Army Corps of Engineers
USDA	U.S. Department of Agriculture
USFW	U.S. Fish and Wildlife
USGS	U.S. Geological Survey
WDR	Waste Discharge Requirements
WSE	water surface elevations
WQIP	Water Quality Improvement Plan

1 Introduction

The City of San Diego Public Works Department has engaged a consultant team to assist in the preparation of a Program Environmental Impact Report (PEIR) for multiple prioritized improvement projects within the Mission Bay Park Improvement Zone (Improvement Zone). The Improvement Zone includes “those areas encompassed within the boundaries of Mission Bay Park, Oceanfront Walk from the Mission Bay Jetty to Crystal Pier and the adjoining coastal parks...” It also includes portions of Rose Creek, Tecolote Creek, and the San Diego River. The ultimate goal is to improve the conditions of the Improvement Zone for the enjoyment of residents and visitors. As part of the PEIR, Preliminary Engineering Reports (PER) are being prepared for the nine prioritized improvement projects. The nine prioritized improvement projects are: Rose Creek Wetland, North Fiesta Island, Tecolote Creek, Leisure Lagoon Marsh (Cudahy Creek), Shoreline Restoration, Habitat Preservation, Bike Ped Paths and Bridges, Seawall Restoration, and Deferred Maintenance.

1.1 Project Overview

The Existing Mission Bay Master Plan identifies the Cudahy Creek region as one of three locations for restoration of tidal wetlands, which balance the need for mitigation, water quality, flood control, aquatic recreation, and public safety (City of San Diego 2002). The current locations of all Mission Bay PEIR wetland restoration projects, including Cudahy Creek, can be seen in Figure 1-2. The Cudahy Creek Cove is an area of open water measuring approximately five acres and located along the eastern shoreline of Mission Bay north of Leisure Lagoon and south of Mission Bay Drive (see Figure 1-1). Two storm drain networks connect to the Cudahy Creek Cove area: (1) Cudahy Creek that outlets through a triple reinforced concrete box (RCB) culvert (each cell six feet wide by five feet high) where the cove area currently extends closest to East Mission Bay Drive and (2) dual 72-inch reinforced concrete pipes (RCPs) located approximately 750 feet northwest of the Cudahy Creek RCBs along the northwest to southeast aligned shoreline of Cudahy Creek Cove (See Figure 1-3). In the vicinity of the Cudahy Creek outlet there are mudflat areas present during periods of low tide levels. Similarly, a small sand bar/mudflat area is located adjacent to and northwest of the dual RCPs outlet. The upland areas both to the north and south of the cove area have turf cover as well as asphalt parking areas used by day visitors to the area and maintained by the City Parks and Recreation Department. The project proposes the creation of approximately 5.2 acres of salt marsh habitat within the Cudahy Creek Cove. This PER identifies the feasibility and workable configuration for the Cudahy Creek Salt Marsh Restoration.

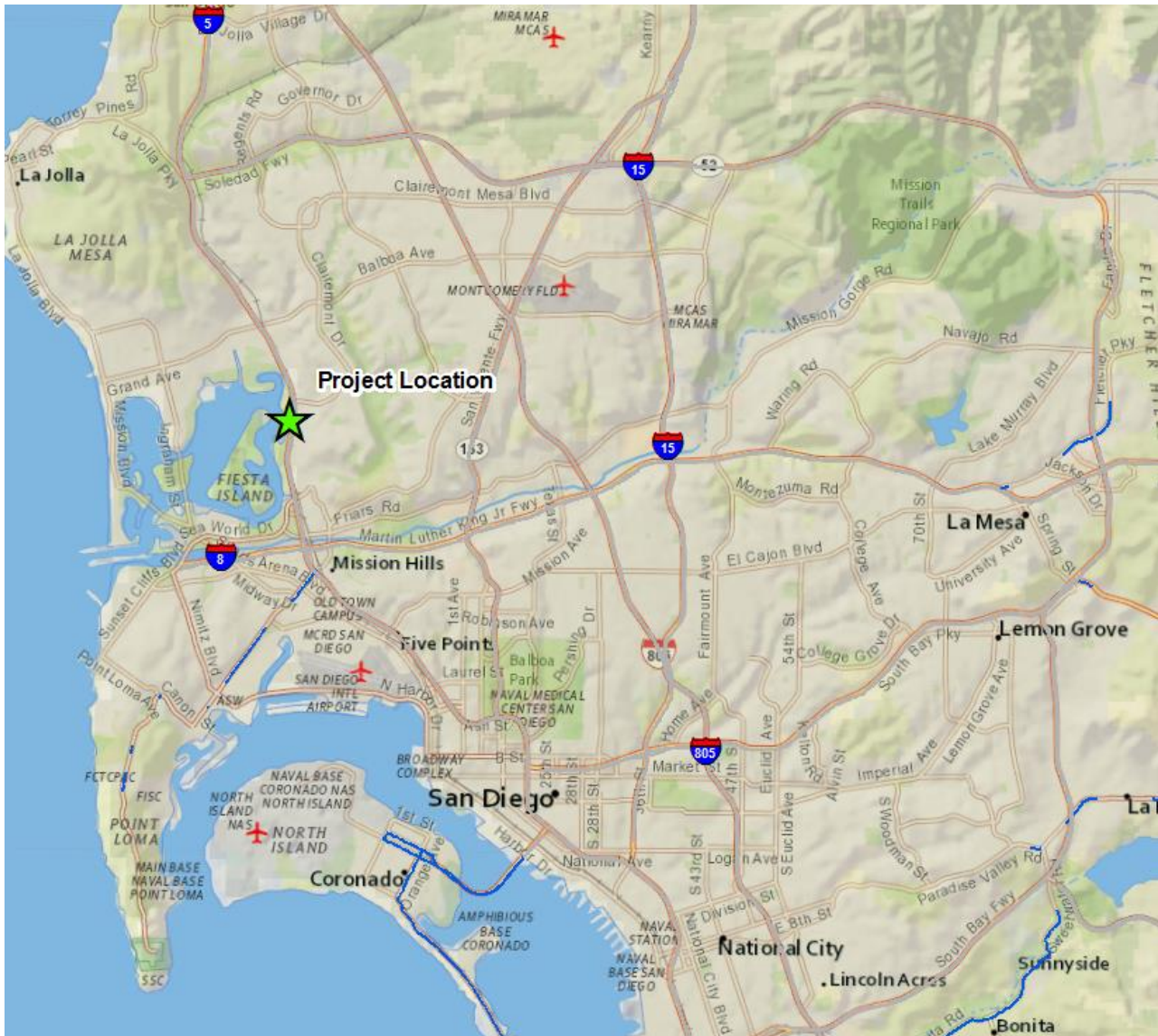

Figure 1-1. Vicinity Map

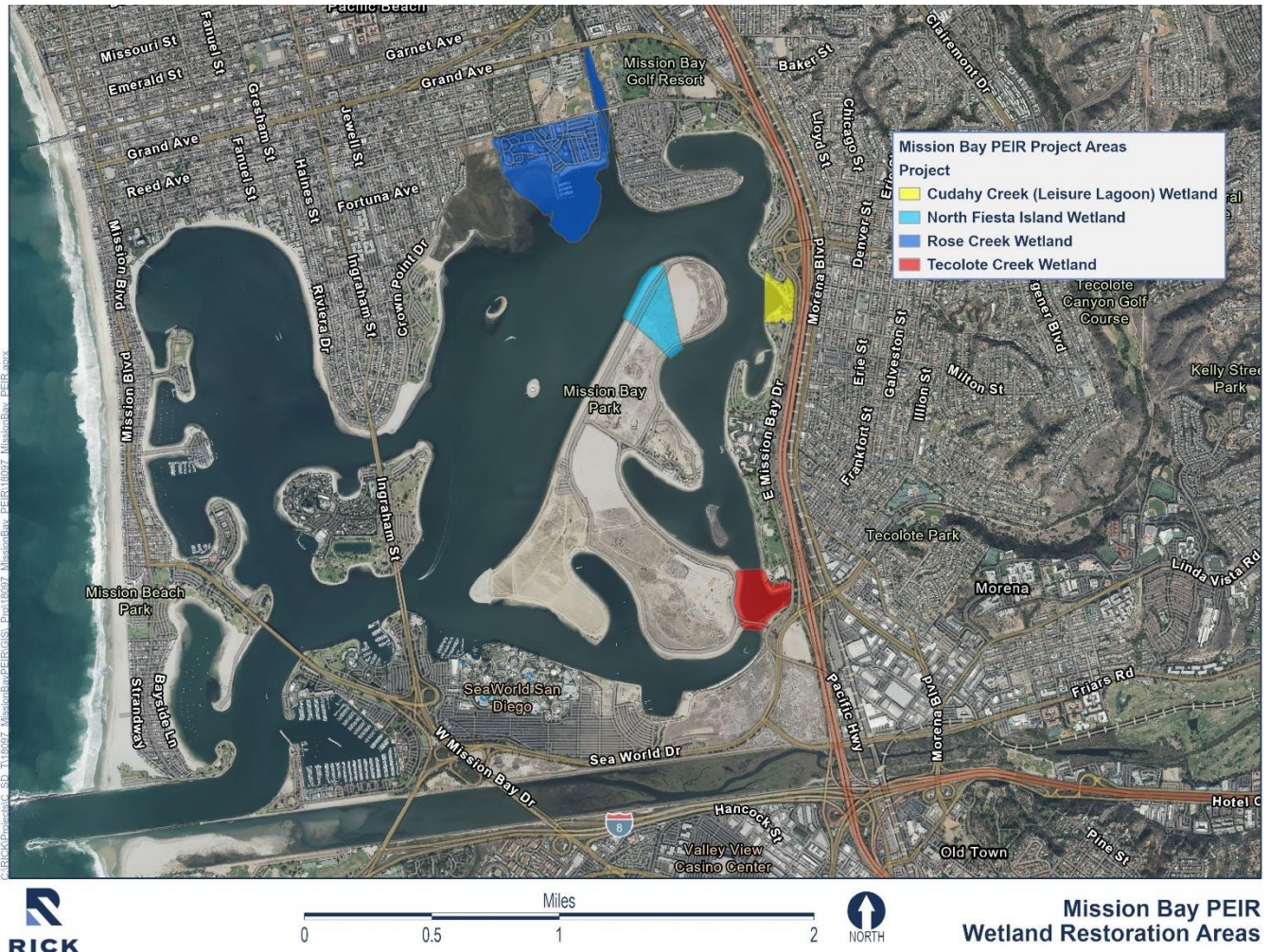

Figure 1-2. Mission Bay Park PEIR Wetland Restoration Project Areas



Figure 1-3. Cudahy Creek Project Location

1.2 Project Location

Mission Bay is located within the City of San Diego, California. This coastal inlet was created over the last 18,000 years, after the last glacial period, as sea level rose to present level and riverine drainage incised the inlet. As sea level rose, the San Diego River deposited large volumes of alluvial sediment to create the delta that became the landmass for Mission Bay, previously known as False Bay (Figure 1-4).



Figure 1-4. Aerial View of Mission Beach and False Bay - 1930 (www.sandiego.gov)

During the 1820s, the San Diego River was redirected from False Bay into the San Diego Bay. This left False Bay as a low-flow marshland. False Bay was made up of fluvial and estuarine fine sand, silts, and clays from the surface to approximately 60 feet (ft) below ground surface (bgs), which were underlain by Quaternary-age dense clayey sands, hard clays, and gravel/cobble from approximately 50-70 ft bgs south of North Mission Bay Drive, and approximately 10-30 ft bgs north of North Mission Bay Drive.

False Bay was historically unnavigable as the channels were narrow and shallow. The City began dredging in 1946 to create Mission Bay Park. Dredging operations, and subsequent land creation with dredged and upland material, occurred between 1946 and 1956, 1959 and 1961, and 1963 and 1964 to create the current configuration of Mission Bay. Landforms, such as Fiesta Island, were formed with what is geologically described as Artificial Fill. This Artificial Fill consists primarily of loose to medium dense silty sands with intermittent layers of soft clay.

1.3 Project Goals and Objectives

The purpose of this report is to provide a preliminary engineering recommendation for restoration efforts of the Cudahy Creek based on the analysis of the existing channel conditions and various alternatives that considered wetland habitat creation, jurisdictional limits, topography, and tidal influence. The preliminary design was formulated with a focus on providing potential benefits related to the overall project goals, which are listed below in Table 1-1. Overall Project Goals and Relative Outcomes Table 1-1

Table 1-1. Overall Project Goals and Relative Outcomes

Overall Project Goals	Project Outcomes
Water Quality Improvements	<ul style="list-style-type: none"> •Tidal circulation during dry weather creates flow for treatment through 5.2 acres of restored wetland area. •Stormwater runoff, produced by an upstream area of 864 acres during wet weather conditions will flow through the restored wetland area and be treated before entering the deeper waters of Mission Bay. •Overall water quality will be improved by removing pollutants from urban stormwater runoff before entering Mission Bay and through tidal circulation during dry weather causing the removal of pollutants from in-situ Mission Bay water.
Aquatic Resources	<ul style="list-style-type: none"> •Historically, wetland loss has been particularly impactful in Southern California. This project aims to reverse this trend by expanding wetland areas and enhancing San Diego's inventory of aquatic resources.
Fish and Wildlife Species	<ul style="list-style-type: none"> •The restored Cudahy wetland area will provide 5.2 acres of wetland habitat that will support a range of species including at least 144 bird species and 56 native plant species that inhabit the Mission Bay area according to Rewild Mission Bay.
Environmental Enhancement	<ul style="list-style-type: none"> •Ecosystem services provided by wetlands such as water purification, flood mitigation, habitat provision and carbon storage that will be achieved in Mission Bay through the Cudahy wetland restoration project.
Recreation	<ul style="list-style-type: none"> •Environmental benefits drawing bird and fish species to the Cudahy wetland restoration project area will provide increased recreational opportunities for activities such as birding and fishing. •Water quality benefits throughout mission bay caused by the wetland restoration will also promote recreational activities that include direct contact with the water in Mission Bay such as paddleboarding, swimming, and kayaking.

The stated overall project goals and potential benefits are discussed through the report narrative and a summary table showing the overall project goals and potential benefits along with qualitative and quantitative outcomes is provided in Appendix F.

2 Data Collection and Existing Characteristics

The scope of this project included performing analyses of the existing topography and upstream storm drain infrastructure to identify a working configuration for implementing a wetland marsh. In support of performing hydraulic analyses of the existing system and developing a design intended to facilitate a wetland marsh, without impacting upstream storm drain infrastructure, the project included data collection through the review of as-built drawings, collection of available topographic and hydrologic data, and review of available reference documents.

2.1 Topography and Bathymetry

Topographic data was obtained from the U.S. Geological Survey (USGS) 2014 Light Detection and Ranging (LiDAR) survey. Bathymetry data, defined as topography of the seabed, was obtained from the Mission Bay Park 2013 Bathymetry and Eelgrass Inventory (Merkel & Associates 2013). These were incorporated into computer aided drafting and design (CADD) files and compiled with aerial data to provide ground surface elevations of the open water area of the cove. It should be noted that topography and bathymetry data were obtained in the North American Vertical datum of 1988 (NAVD 88). A conversion between the NAVD 88 and National Geodetic Vertical Datum (NGVD 29) was performed, ensuring all analyses have been referenced to the NGVD 29 datum. Additional topographic survey data was collected by Photo Geodetic Corporation in April 2019. The horizontal basis of coordinates for this survey is referenced to the California Coordinate System of 1983 (CCS83) Zone 6, North American Datum of 1983 (NAD 83), and elevations are referenced to NGVD 29. Features from the 2019 survey, such as stormwater structures, asphalt concrete, sidewalks, fire pits, power poles, etc. were compiled into CADD.

2.2 As-Built Drawings

As-built drawings for the project were obtained from the City of San Diego Development Services Department. A summary of the as-built plans reviewed is provided in Table 2-1, and the as-built plans are provided in Appendix A.

Table 2-1. Summary of City of San Diego As-Built Drawings Reviewed

City of San Diego As-Built Drawing	Construction Completion Date	Relevant Data Obtained
9355-L	12/8/1952	Configuration of storm drain upstream of the Interstate 5 freeway culvert
13078-9-D	3/05/1969	Dimensions of existing south culvert

2.3 Available GIS Data

The available geographic information system (GIS) data was collected from the San Diego Geographic Information Source (SanGIS). Data was reviewed for information regarding land use and existing utilities in the area. The parcel data was used for site layout. It should be noted that the location of property lines shown in the preliminary design concept is not exact but provides an approximation for conceptual design. The existing utility data from SanGIS was used for preliminary layout and identification of the wet utilities that may exist in the project area. A detailed survey of existing utilities is nonetheless recommended prior to any final engineering design for the project area.

In some cases, the parcel lines did not align well with the georeferenced 2014 aerial image and contours, therefore, adjustments were made to align specific parcel lines to existing fence lines and road alignments, when applicable. Specific items of importance including culvert crossings, existing storm drains, and utility crossings were reviewed further through available as-built plans and/or site visits when necessary.

The data layers used from SanGIS inventory are shown in the table below.

Table 2-2. SanGIS Data Inventory

Data Layer	Version Date	Source (Agency)
LiDAR	2014	SanGIS, SANDAG, NGA, LECC, Regional Public Safety GIS, 18 Incorporated Cities
Aerial Imagery	September 14, 2011	City of San Diego
Aerial Imager (Figure 1-2, 1-3)	November 2014	SANGIS
Storm Drain Network Files (Drain Conveyance, Drain Structures)	October 17, 2018	City of San Diego, SanGIS, SANDAG
Land Use	January 1, 2017	SanGIS, SANDAG
Hydrologic Soil Groups (SSURGO)	November 11, 2013	National Resources Conservation Service
Parcel Layer	February 15, 2018	SanGIS, SANDAG, Assessor/Recorder/County Clerk
Floodplain Layers	April 7, 2016	Federal Emergency Management Agency
Utility Layers (Sewer Main, Water Main)	March 5, 2018	SanGIS, SANDAG
Census Block District Groups	April 25, 2016	City of San Diego
Municipal Boundaries	July 25, 2011	SanGIS, SANDAG
National Hydrography Dataset Flowline	April 12, 2016	U.S. Geological Survey

2.4 Existing Conveyance Systems

There are two main storm drain outfalls that outlet into the project area. The northern outfall, herein referred to as Cudahy – North, is a dual 72-inch reinforced concrete pipe (RCP) with an outfall invert of approximately -1.0 foot NGVD 29. The Cudahy – North storm drain extends northeast beneath Interstate 5

and continues in a north easterly direction, collecting runoff from approximately 449 acres. The Cudahy – North outfall outlets directly into the project area.

The southern outfall, herein referred to as Cudahy – South, is a triple-cell six feet (width) by five feet (height) reinforced concrete box (RCB) with an outfall invert of approximately -1.0 foot NGVD 29. The Cudahy – South storm drain extends east beneath Interstate 5 and continues in an easterly direction, collecting runoff from approximately 415 acres. The Cudahy – South outfall outlets onto a rip rap pad before discharging into the project area.



Figure 2-1. Existing Storm Drain Outfalls

The remainder of the project area consists of an approximately 5-acre portion of Mission Bay adjacent to the shoreline subject to tidal influence and flow patterns of Mission Bay. Figure 2-2 below displays the approximate project area and the two main storm drain outlets, Cudahy – North (Double 72" RCP) and Cudahy – South (Triple 6'x5' Concrete Box).



Figure 2-2. Existing Project Area, Outfalls, and Storm Drains

3 Existing Conditions

Cudahy Creek is located in western San Diego County and includes a drainage area of approximately 864 acres. The creek drains directly into Mission Bay as part of the Miramar Hydrologic Area (HA), and the larger Mission Bay/La Jolla Watershed Management Area (WMA) encompassing an area of 64 square miles (PCW 2020).

The project includes the design of stormwater infrastructure features, and pursuant to City of San Diego policy, the design of the proposed improvements must be based on hydrologic and hydraulic analyses performed in accordance the current City guidance.

3.1 Hydrology

Hydrologic analysis was performed for the drainage that is associated with the Cudahy Creek Outfalls. This included delineating the drainage areas, determining the hydrologic parameters for the watersheds, and performing hydrologic calculations to determine the peak flow rates and hydrographs. The peak flow rate is needed for hydraulic analysis to ensure the existing or proposed structure (bridge, culvert, storm drain etc.) has the capacity to convey large storm events. Watersheds were delineated using the 2014 SanGIS LiDAR data. The watersheds to the Cudahy Creek Outfalls (North and South) are less than one square mile, and thus in accordance with *The City of San Diego, Transportation & Storm Water Design Manual, Drainage Design Manual (Drainage Design Manual)*, dated January 2017 (San Diego 2017), rational method calculations were used determine existing condition peak flow rates for the 100-year frequency storm events.

The current land uses and soil type within the watersheds were used to determine the overall runoff coefficient (C) for each watershed. The runoff coefficient (C) is the fraction, with a range of zero to one, of the rainfall that runs off the surface and is based on land use and soil group. Typical values for urban areas are between 0.55 and 0.75. The current land use types for each watershed were based on the 2017 SanGIS land use data and are shown on the Cudahy Creek Hydrologic Workmap in Appendix A. The hydrologic soil group was based on the Soil Survey Geographic Database (SSURGO) soil maps.

To find the intensity (I), time of concentration (T_c) was calculated. The T_c is the time it takes for water to flow from the most remote part of the watershed to the point of interest and this value is based on considering the drainage area geometry (i.e., size), flow length, topography, and best professional judgement. Using the Intensity-Duration-Frequency Curves for the City of San Diego, provided in Appendix A of the Drainage Design Manual, intensities for each watershed were obtained. See Table 3-1 for a summary of the parameters for Cudahy Creek Outfalls and see Appendix A for backup exhibits and calculations of the peak flowrates:

Table 3-1. Key Rational Method Parameters Summary

Hydrologic Parameter	Cudahy – North Outfall	Cudahy – South Outfall
Basin Area (A)	449 acres	415 acres
Runoff Coefficient (C)	0.70 (no units)	0.68 (no units)
Time of Concentration	23 minutes	13 minutes
100-year Intensity (I)	2.3 inches/hour	3.1 inches/hour

Additionally, 6-hour duration storm event hydrographs were generated using the peak flowrates calculated pursuant to the Drainage Design Manual. The peak flow rate for the 100-year storm event was used for hydraulic calculations. See Appendix A for the 6-hour hydrographs. Table 3-2 provides a summary of the hydrologic results. The support materials for the hydrologic calculations are provided in Appendix A.

Table 3-2. Summary of Hydrologic Data

Drainage Area	100-year Storm Event Peak Flow Rate (cfs)
Cudahy – North	723
Cudahy – South	870

3.2 Hydraulics

Hydraulic analyses were performed to determine hydraulic characteristics for the existing conditions and the proposed design, including water surface elevations, limits of inundation and channel velocities. The hydraulic analyses were used to guide planning and design of the project. The hydraulic analyses were completed using the US Army Corps of Engineers Hydrologic Engineering Center River Analysis System (HEC-RAS) Version 5.0 program. The HEC-RAS program models the characteristics of applicable water courses and flow paths and determine the velocity, water surface elevations and spatial limits of inundation associated with the peak flows from for both the 100-year storm event and the 10-year storm events. The HEC-RAS Version 5.0 program has the ability to compute two-dimensional flow models. For this project a two-dimensional model was created to analyze the hydraulic characteristics of the preliminary design. Since the outlet(s) of this project area will eventually discharge into Mission Bay and are subject to tidal influence, different models were created with varying downstream water surface elevations (WSE) to account for the different tide levels.

Hydraulic analyses performed include the following:

- 100-year peak flow rate with the downstream WSE at -2 feet (referenced to NGVD 29)

- 100-year peak flow rate with the downstream WSE at mean sea level (i.e., 0 elevation referenced to NGVD 29)
- 100-year peak flow rate with the downstream WSE at 2 feet (referenced to NGVD 29)
- 100-year peak flow rate with the downstream WSE at 1 foot (referenced to NGVD 29)

3.3 Astronomical Tides

Astronomical tides are crucial to understanding daily inundation potential in Mission Bay and habitat establishment constraints and opportunities. Still water level (SWL) is defined as average water surface elevations at any instant, excluding local variation due to waves, wave run-up, and wave setup, but including the contributions of tide, storm surge, and SLR. SWL for various tidal levels are presented in Table 3-3.

The Mean lower-low water (MLLW) elevation of -2.32 feet NGVD 29 represents the change from sub-tidal to tidal zones. The Mean higher-high water (MHHW) elevation of 3.00 feet NGVD 29 represents the boundary between the tidal zone (i.e., daily wetting and drying) and transitional zone (i.e., periodically inundated during storm wave and extreme tide conditions). The Highest Observed Tide (HOT) represents the extreme SWL scenario.

Table 3-3. Existing Still Water Levels in Mission Bay (NOAA Station 9410230)

Datum	Abbreviation	Existing SWL (ft, NGVD 29)
Highest Observed Tide (11/25/2015)	HOT	5.49
Mean Higher-High Water	MHHW	3.00
Mean High Water	MHW	2.28
Mean Sea Level	MSL	0.41
National Geodetic Vertical Datum of 1929	NGVD 29	0.00
Mean Low Water	MLW	-1.42
North American Vertical Datum of 1988	NAVDv88	-2.13
Mean Lower-Low Water	MLLW	-2.32
Lowest Observed Tide (12/17/1937)	LOT	-5.19

3.4 Measured Tides

As a part of the Mission Bay PEIR Hydrology Study (Moffat & Nichol, 2019), four pressure gauges were placed at sub-tidal locations collecting tide measurements to assess the tidal behavior of Mission Bay. No anomalous behavior of Mission Bay tides was identified in comparison with tidal measurements from the La Jolla, CA Station 9410230 (NOAA 2019). Figure 3-1 shows existing tides as measured near south Fiesta Island as compared to ocean tides. There is virtually no measurable difference between bay tides and those of the ocean.

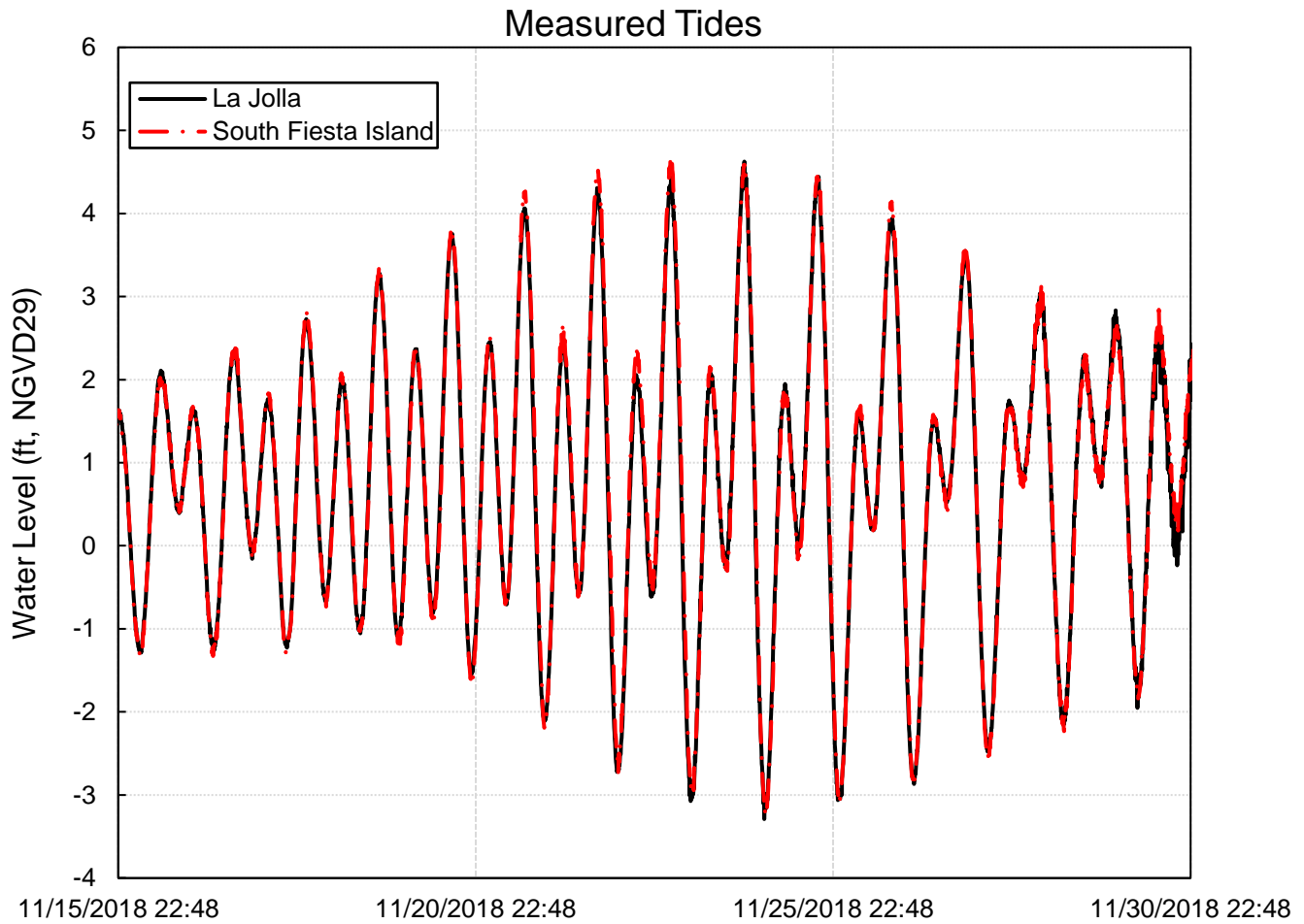

Figure 3-1. Measured Tides at Mission Bay and the Open Ocean

3.4.1 What is Sea Level Rise?

Anticipated changes in climate and sea level are a result of increasing concentrations of “greenhouse” gases in the atmosphere over time due to emissions from natural sources and the burning of fossil fuels. Greenhouse gases trap long-wave thermal radiation within the atmosphere, which causes warming of the Earth’s atmosphere, lands, and oceans, resulting in climate changes and SLR (IPCC 2013). SLR science involves both global and local physical processes. Models are created based on science’s best understanding of atmospheric, oceanographic, and geological processes on global and local scales and, therefore, are dynamic and periodically updated to reflect changes. On a global level, the most recent predictions come from the IPCC Fifth Assessment Report (AR5), released in 2014. The AR5 projections for SLR were 50% higher than the IPCC Fourth Assessment Report (AR4) (released in 2007) due to the addition of ice sheet dynamics on SLR. A sixth IPCC Assessment Report (AR6) was released in 2021 but that document does not affect the SLR projects in this PER because they are based on State Guidance as discussed in subsequent sections.

At the state level, the California Coastal Commission (CCC) presently recommends using the best available science. The State of California Ocean Protection Council (OPC) Science Advisory Taskforce updated the best available science through the “Rising Seas in California: An Update on Sea Level Rise Science” report which factored polar ice sheet melting into future SLR projections (OPC 2017). The 2017 report forecasts SLR for multiple emissions scenarios and uses a probabilistic approach based on Kopp et al. 2014. The following year, the OPC released an updated California State SLR Guidance based on the 2017 science update, which set the standard for local, regional, and state level SLR planning (OPC 2018). For both low- and high-emission scenarios, a likely range was determined based on Kopp et al. 2014 that estimates a 66% probability that SLR will be within that range. For the low emissions scenario, the likely range of SLR for 2100 is 1.1 feet to 2.5 feet and for the high emissions scenario, the likely range for 2100 is 1.8 feet to 3.6 feet. The OPC’s 2017 report and 2018 guidance include a specific singular scenario called H++, which represents recent scientific findings of faster rates of SLR due to previously unknown glacial dynamics by Sweet et al., 2017, which predicts 10.2 feet by Year 2100. The likelihood of this scenario is unknown and is recommended by the OPC to be considered for long-term, high-stakes decisions (OPC 2018).

Climate science is a constantly changing field, often with high degrees of uncertainty about Representative Concentration Pathways (RCP), which are four greenhouse gas (GHG) concentration trajectories adopted by the IPCC for its Fifth Assessment Report in 2014. The four RCP scenarios are 2.6, 4.5, 6.0, and 8.5. RCP 2.6 is the low emissions trajectory, requiring stringent mitigation scenarios for GHG emissions, and RCP 8.5 is the “business-as-usual” fossil-fuel-intensive emission trajectory. The intermediate scenarios represent mid-range levels of emissions reductions. RCP 8.5 represents high emissions and is the upper bound of SLR projections. RCP 8.5 represents the worst-case scenario and is most commonly used for conservative predictions of SLR. Per OPC guidance, this report includes the RCP 8.5 trajectory because, to date, GHG emissions worldwide have followed the business-as-usual trajectory (OPC 2018). This study refers to “emissions scenarios” rather than “GHG concentration scenarios” when addressing SLR scenarios. Planning for a varying degree of SLR can be challenging and requires continual or periodic updates based on the most recent predictions.

3.4.2 Selected Sea Level Rise Scenarios

The current best available SLR science is the State of California OPC Science Advisory Taskforce April 2017 report and corresponding 2018 California State Guidance (CCC 2018). Projections for San Diego, CA, and by association Mission Bay, range widely with respect to GHG emission scenarios and probability. Projected SLR scenarios under the high emissions scenario and varying probabilities for San Diego are presented in Table 3-4 and Figure 3-2 (Per OPC 2018).

Table 3-4. Sea Level Rise Projections – San Diego, CA

Year	50% Probability SLR Scenario	17% Probability SLR Scenario	5% Probability SLR Scenario	0.5% Probability SLR Scenario	Extreme (H++) SLR Scenario
2030	0.5 ft	0.6 ft	0.7 ft	0.9 ft	1.1 ft
2050	0.9 ft	1.2 ft	1.4 ft	2.0 ft	2.8 ft
2100	2.6 ft	3.6 ft	4.6 ft	7.0 ft	10.2 ft

(Adopted from OPC 2018, Table 34, High Emissions Scenario)

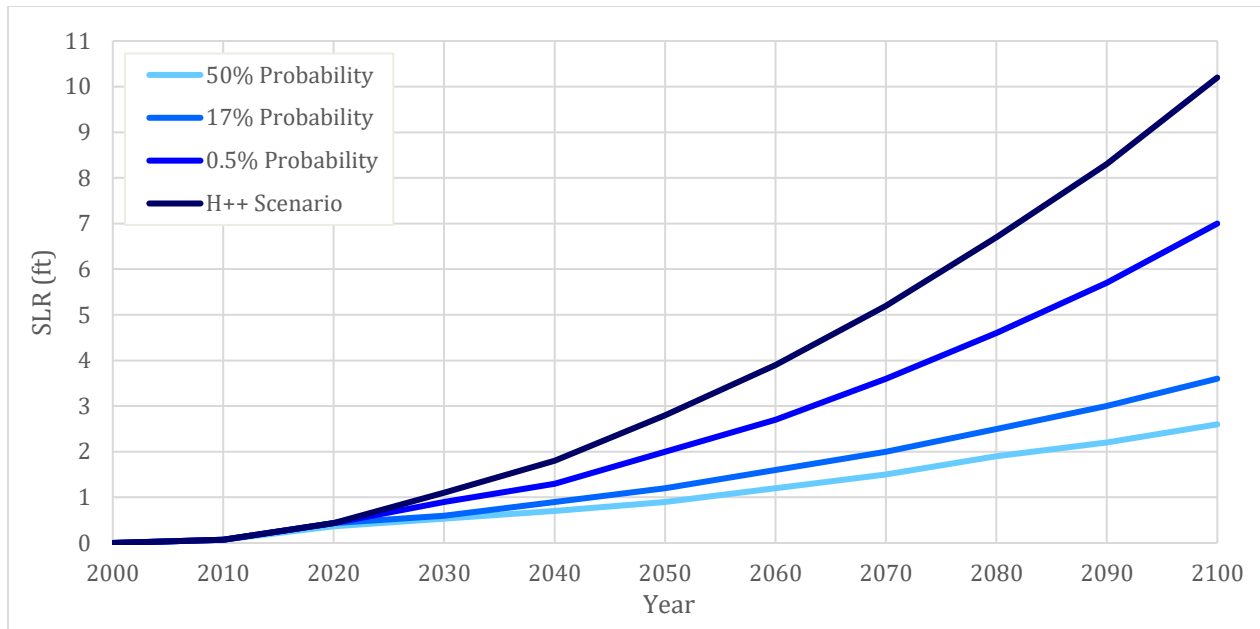

Figure 3-2. Sea Level Rise Projections – San Diego, CA

Due to the high degree of uncertainty associated with predicting when and at what rate SLR will occur, this study looks at a range of two scenarios that capture the range of predicted SLR rates and critical points for the study area. For the purposes of this study, the following two SLR scenarios are considered:

- Low SLR Scenario: 3.6 feet (1.1 meters) and
- High SLR Scenario: 7.0 feet (2.1 meters).

These two scenarios correspond approximately with the Year 2100's 17% and 0.5% probabilities, respectively, and are in line with the City of San Diego Sea Level Rise Vulnerability Assessment (San Diego 2019).

SLR will result in the migration of existing Mission Bay wetland habitats upward and/or in the landward direction. For the purposes of wetland planning, SWLs under SLR scenarios are projected to pinpoint tidal elevations important to habitat and public use. Existing SWL elevations and future elevations based on the two chosen SLR scenarios are provided in Table 3-5.

Table 3-5. Sea Level Rise Projected Still Water Levels

Datum	Abbreviation	Existing SWL (ft, NGVD29)	3.6 ft SLR SWL (ft NGVD29)	7.0 ft SLR SWL (ft NGVD29)
Highest Observed Tide (11/25/2015)	HOT	5.49	9.09	12.49
Mean Higher-High Water	MHHW	3.00	6.6	10
Mean High Water	MHW	2.28	5.88	9.28
Mean Sea Level	MSL	0.41	4.01	7.41
National Geodetic Vertical Datum of 1929	NGVD 29	0.00	3.6	7
Mean Low Water	MLW	-1.42	2.18	5.58
North American Vertical Datum of 1988	NAVD 88	-2.13	1.47	4.87
Mean Lower-Low Water	MLLW	-2.32	1.28	4.68
Lowest Observed Tide (12/17/1937)	LOT	-5.19	-1.59	1.81

4 Preliminary Design

A preliminary design for the Cudahy Creek Cove wetland areas was prepared to identify the areas and elevations of low salt marsh, transitional areas, and mid salt marsh areas; geometry and layout of subtidal channels; and the design of riprap to provide stabilization for subtidal channel bottom and side slope areas, where applicable. The existing Mission Bay Park Master Plan Update identifies the Cudahy Creek wetland area as one of three locations for restoration of tidal wetlands where the ultimate wetland area should be derived from balancing mitigation, water quality, flood control, aquatic recreation, and public safety (City of San Diego, 2002). A preliminary analysis of the constraints and opportunities to provide wetland treatment at Cudahy Creek was prepared by Merkel & Associates, Inc. (Merkel, 2003). Both referenced documents along with ongoing coordination with City Planning Department staff were utilized to determine the basis of design for the Cudahy Creek Cove wetland area. The 2003 Merkel & Associates, Inc. preliminary analysis included the preparation of a cursory level, conceptual design for saltwater marsh within the cove and was used as a starting point for the horizontal and vertical layout of the wetland design.

One key component not explicitly included in these referenced documents is an analysis of the maintenance requirements and frequencies, specifically sediment removal. The goal of the conceptual design prepared for this study is a wetland configuration that may reduce the need for maintenance and may result in a sustainable storm drain conveyance system through the wetland habitat to the open water area of Mission Bay.

Hydraulic modeling was performed using the USACE HEC-RAS to analyze the function of the wetland during storm event peak flows for various tide level conditions. This included preparing a 3-dimensional digital elevation model (DEM) of the proposed wetland and performing 2-dimensional hydraulic analysis to guide design refinements. See Figure 4-1 below for a depiction of the preliminary design and the included components.

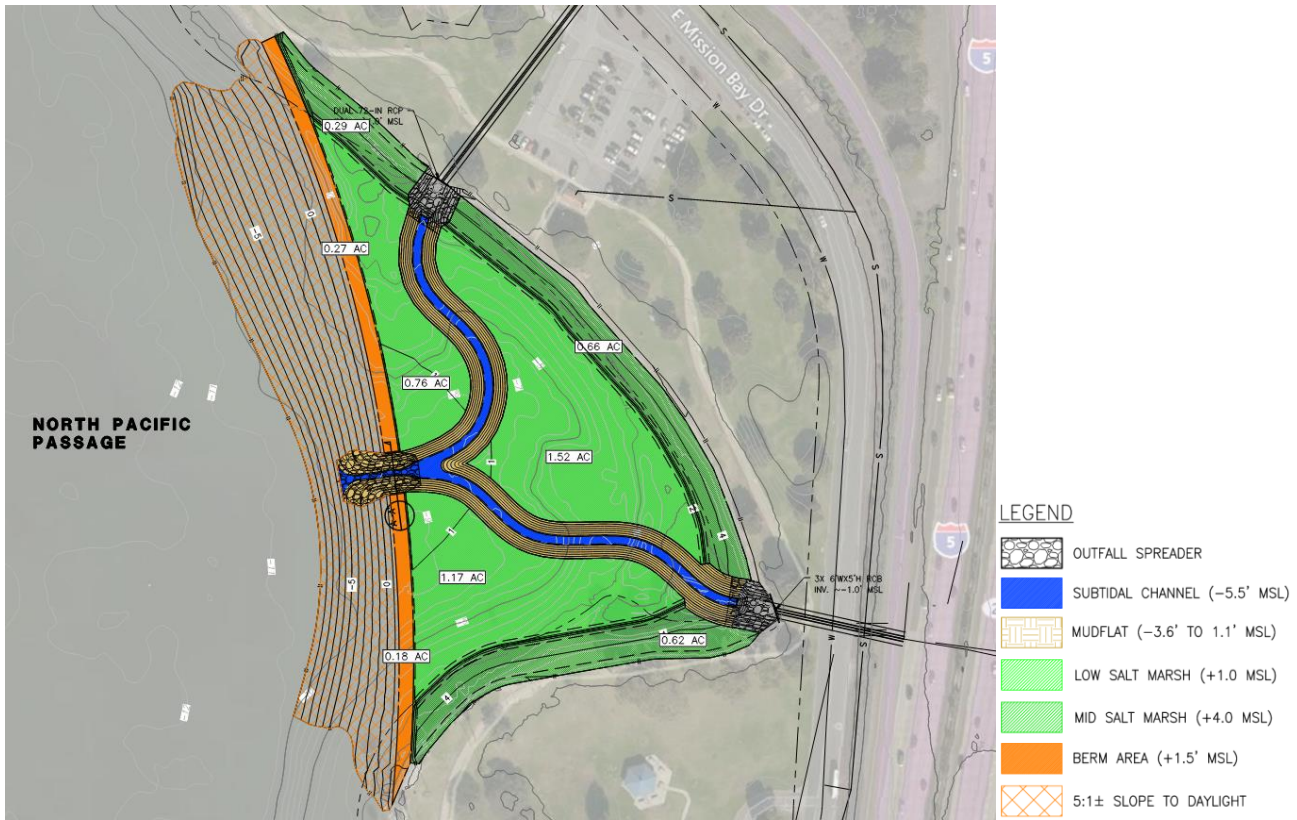

Figure 4-1. Preliminary Design Concept

4.1 Project Components

The project components consist of low salt and mid salt marsh restoration area, subtidal channels, berm, oyster bags, and riprap revetment within the Cudahy Creek Cove. The marshes will provide water quality treatment of storm water and bay water as well as provide an amenity to the public (e.g., native plant and bird viewing). A subtidal channel is proposed to convey flows from the existing outfalls. A berm is proposed along the wetland limits to the open water of the bay. Oyster bag stabilization is proposed on the outer fill slope of the project area. Oyster bags and the resulting oyster population serve to improve water quality by filtration. Slope stabilization intended to be fostered by the inclusion of oyster bags in the Cudahy wetland restoration design may create sharp edges that restrict swimming and beachgoing in the immediate area. However, the distributed water quality benefits will support ecosystems birders and fisherman rely on and promote swimming and other direct water activities due to water quality improvements. In addition, signs informing the public about the presence of oyster bags can include hazard warnings, protecting the public and simultaneously contributing to environmental awareness and education. Riprap revetment is proposed at the existing outfalls and the connection of the subtidal channel with the open water in the bay to prevent erosion.

The soils used for wetland restoration shall be approved by a biologist prior to import to ensure that they will support coastal wetland habitat. Concurrent projects that involve excavation such as the Mission Bay

Navigational Safety Dredging Project or future projects proposed within Mission Bay including the Rose Creek Wetland Project and Fiesta Island Wetland Project provide multiple local opportunities for sourcing the material required for wetland construction. Repurposing excavated soil from other Mission Bay projects will decrease transportation costs and increase the likelihood that imported soil will be biologically compatible. To make the berm area of the project structurally sound, oyster bags are proposed as a cover to keep the soil in place. The oyster bags and vegetation will act to stabilize the berm and should provide adequate support.

Mitigation ratios for disturbed sensitive habitat are determined through discussion with resource agencies. The habitat creation goals of the project total approximately 5.2 acres of salt marsh habitat, and therefore mitigation credits are anticipated. The existing habitat and proposed salt marsh habitat areas for the Project are listed in Table 4-1.

Table 4-1. Existing and Proposed Habitat Areas

Existing Habitats	Mapped Acreage	Proposed Habitats	Designed Acreage
Subtidal/Open Water	8.1	Subtidal/Open Water	4.0
Mudflat	0.0	Mudflat	0.0
Low marsh	0.0	Low marsh	3.7
Mid marsh	0.0	Mid marsh	1.5
High marsh	0.0	High marsh	0.0
Transitional	0.0	Transitional	0.3
Disturbed Habitat/Upland	0.9	Disturbed Habitat/Upland	0.2
Disturbed Salt Marsh	0.0	Disturbed Salt Marsh	0.0
Beach	0.9	Beach	0.0
Riprap	0.0	Riprap	0.2
TOTAL AREA	9.9	TOTAL AREA	9.9

4.1.1 Subtidal Channels

The proposed subtidal channels have two main purposes: (1) during wet weather, the subtidal channels will provide a connection between each of the two storm drain outfalls and the open water area of Mission Bay (i.e., to provide conveyance for storm water runoff through the wetland area and to the North Pacific Passage of Mission Bay) and (2) allow tidal fluctuations to result in wetland inundation and subsequent drainage of the wetland areas. That is during flood tide conditions, the subtidal channels water level elevations will rise with the tide levels and allow bay water to inundate the salt marsh wetland areas. During ebb tide conditions, the subtidal channels will allow the salt marsh areas to drain by carrying water out of the wetland area and back to the Mission Bay open water. This process of inundation and draining is necessary for the health of the salt marsh wetland and provides water quality benefit by circulating water through the wetland, which results in filtering through the vegetation and wetland soils prior to being returned to the bay. Depending on the tide level during wet water, a varying portion of the storm water runoff will exceed the capacity of the subtidal channel and flow into salt marsh area, which will provide

water quality benefit to the storm water runoff. The design geometry of the subtidal channels includes a bottom width of 11 feet at an elevation of -5.5 NGVD 29, which is lower than the lowest tide (lowest tide is - 5.19 feet NGVD 29 based on Table 3-3). The side slopes of the subtidal channels are proposed at 3:1 (horizontal to vertical). This geometry results in a total channel top width of approximately 50 feet through the low salt marsh wetland area.

4.1.2 Subtidal Channel Stabilization

The results of the hydraulic modeling indicate that the subtidal channel will require stabilization at three locations: (1) Cudahy - North outlet, (2) Cudahy - South outlet, and (3) the connection area with the Mission Bay North Pacific Passage. In the areas of the storm drain outlets, the riprap shall be at the elevation of the storm drain system (approximately -1.0 foot NGVD 29) for a distance of 30 to 40 feet followed by a transition down to the subtidal channel geometry, which has a bottom depth of -5.5 feet NGVD 29. In the area of the subtidal channel connection with the North Pacific Passage, the two subtidal channels merge resulting in greater flow and velocity in comparison to the individual channel reaches. Additionally, through the iterative design process the subtidal channel geometry at the wetland exit has been manipulated with steps, or benches, and a reduced channel bottom width. These design considerations produce an increase in storm water runoff flow onto the low salt marsh areas (and the associated water quality benefit provided by doing so). It should be noted that without this manipulation the hydraulic modeling results indicate that the channel would still require stabilization. In fact, the modeling shows that less area requires protection for the manipulated geometry than keeping the geometry constant. As such, the channel geometry manipulation has a dual positive impact for the wetland (i.e., increase water quality benefit and reduce stabilization area). Based on the results of the hydraulic modeling, a riprap class of 2-tons is required.

4.1.3 Salt Marsh Wetland

A combination of low, transitional, and mid salt marsh wetland areas are proposed in the Cudahy Creek Cove salt marsh restoration area. Approximately 3.3 acres of low salt marsh area is proposed adjacent to the side of the proposed subtidal channels. The proposed elevation of the low-salt marsh varies from approximately 0.9 feet NGVD 29 to approximately 1.1 feet NGVD 29. The slight variation in elevations is proposed to promote drainage of the area during periods between inundations. The proposed elevations are on the lower end of elevation range in which low salt marsh will be sustainable, and the elevations were selected to balance the water quality objective and the habitat mitigation objective. That is, by having the low salt marsh elevation at approximately 1.0 foot NGVD 29, on an average annual basis, a greater portion of storm water runoff will be conveyed onto the low salt marsh wetland area, which will provide additional water quality benefits in comparison to have the low-salt marsh at a higher elevation (e.g., 2.0 feet NGVD 29). Additionally, the selected elevations being at the lower range of the low salt marsh range will allow the vegetation a greater ability (i.e., range) to adapt to sediment deposition should very large storms with large sediment loading occur (sediment loading potential is discussed in more detail in section 5.1.5 Maintenance Requirements). Along the perimeter of Cudahy Creek Cove, approximately 1.4 acres of mid salt marsh is proposed. The width of the mid salt marsh varies slightly, but in general is approximately 50 feet. The mid salt marsh wetland is proposed at an elevation of 4.0 feet NGVD 29. Between the low and mid salt marsh

areas, an area with a width of 12 feet is proposed as transitional. This results in a design slope of 4:1 (horizontal to vertical), which has an adequate grade for a quick transition while being flat enough to promote vegetation and reduce the risk of erosion.

4.1.4 Berm Area

A 20-foot wide berm area is proposed between the proposed salt marsh wetland areas and the North Pacific Passage of Mission Bay for the entire length of the wetland except in the area where the subtidal channel is proposed to connect to the Mission Bay open water. The proposed elevation of the berm is 1.5 feet NGVD 29. As such, the berm area will consist of low salt marsh wetland habitat (approximately 0.35 acres in addition to the amount described above). The berm will serve to contain water in the wetland area in order to promote the filtration of the water through the vegetation and to improve the water quality benefit of the system. For example, if the tidal level is approximately 0.9 feet to 1.4 feet NGVD 29 and wet weather runoff enters the wetland from the outfalls, the berm would effectively be a barrier between the wetland and Mission Bay resulting in a large portion of the storm water runoff being forced onto the low salt marsh wetland. During periods of tide levels above 1.5 feet NGVD 29 there will be a direct exchange of water between the wetland area and Mission Bay (i.e., water will flow over the top of the berm). This tidal inundation is necessary for wetland health and will result in additional water quality benefit.

4.1.5 Oyster Bag Slope

Along the west side of the proposed fill area constructed to create the wetland will be a sloped area that ranges in elevations from approximately 1.5 feet NGVD 29 at the berm area down to the bottom of Mission Bay, which is at an elevation of approximately minus 10 feet NGVD 29. The proposed slope is 10:1 (horizontal to vertical) and has been designed to make a near seamless connection to the existing slopes of the North Pacific Passage north and south of the project wetland area. Oyster bags, oyster panels, or similar product, may be placed along the slope to culture the growth of oysters. Oysters provide water quality benefit through filter-feeding, which removes nutrients from the water by consuming and assimilating the nitrogen and phosphorus into their tissue and shells (Oyster Recovery Partnership, n.d.)

Preliminary Drawings

A preliminary set of construction drawings of the project can be found in Appendix B. Drawings are currently in draft phase and are not for construction.

Drawings of the Cudahy Creek (Leisure Lagoon) Wetland Restoration include the project components and design criteria stated in Section 4.1 (Project Components).

4.1.6 Wetland Inundation and Water Quality

The salt marsh wetland elevations were selected based on the data presented in the *ReWild Mission Bay: Wetlands Restoration Feasibility Study Report* (Everest, 2018) in order to provide assurance that the salt marsh wetland will be successful. The cited study performed transects to identify the range that each type of salt marsh wetland vegetation exists in areas where there is existing salt marsh wetland habitat in Mission Bay,

specifically near the Rose Creek inlet and the Kendal-Frost Marsh Reserve/Northern Wildlife Preserve. Based on data presented in the cited feasibility study, low salt marsh wetland exists between elevations of 0.3 feet to 2.3 feet NGVD 29. As such, low salt marsh wetland proposed at elevation between 0.9 feet and 1.1 feet NGVD 29, near the middle of the overall range, is anticipated to receive the appropriate frequency and duration of tidal inundation to be successful. In order to provide additional context related to the proposed low salt marsh wetland tidal inundation, a inundation frequency analysis was performed as detailed below.

Inundation Frequency Analysis

A tidal inundation frequency analysis was performed in order to estimate the percentage of time that the wetland will be inundated and thus the time that interaction will occur between bay water and the Cudahy wetland resulting in quality improvements. Inundation frequency is the percentage of time that the tidal elevation exceeds a certain elevation. The treatment of both wet weather and dry weather flows is expected to occur when the wetland salt marsh is inundated (tide levels at or above 1.1 feet NGVD 29). During dry weather, at tidal level below 0.9 feet NGVD no low salt marsh wetland will be inundated and now interaction between the wetland and bay will occur. During wet weather, at tidal level of 1.1 feet NGVD and below, the majority of the runoff from the outfalls will be conveyed in the subtidal channel and to Mission Bay and will be less likely to be treated. Hourly Tidal data was obtained for the period of 2001 through 2018 for the La Jolla Tidal Gage from the National Oceanic and Atmospheric Website (<https://tidesandcurrents.noaa.gov>). The Tidal data was exported to Microsoft Excel post-processing worksheets and was evaluated in order to calculate the time of inundation. The analysis results indicate that tidal level above 1.1 feet NGVD 29 will occur approximately 27% of the time. In general, inundation will occur on a daily basis. According to the International Stormwater BMP Database, 2016 Summary Statistics Final Report (WERF, 2017) approximately 54% of (total suspended solids (TSS) is removed by wetland basins; however, additional information related to that study as well as additional analysis of the Cudahy wetland area would be required to provide an estimate of the pollutant removal efficiency that will be provided on a per storm event or annual basis.

Stormwater Pollutant Characterization

Outfall testing is done annually for the Mission Bay watershed but not specifically for the Cudahy Outfalls. The results of the Mission Bay testing are presented in the Water Quality Improvement Plan (WQIP) Annual Report and could be used to give a typical pollutant profile for Cudahy Creek runoff. In general, the pollutants in stormwater runoff may be toxic to benthic fauna, but not to vegetation. Additionally, the micro-organisms in the soil help with pollutant removal and toxicity reduction through oxidation, reduction, degradation and assimilation (Alexander, 1977).

4.1.7 Fencing

Perimeter fencing is proposed for this Project to restrict access and allow the site's vegetative community time to develop and mature post-construction. The fencing will reduce the risk of damage to the salt marsh caused by either foot traffic, animals, or unauthorized vehicular traffic. A 6-foot-high chain-link fence is

assumed for this project, although other exclusion fence types may be explored. Gates will be included to allow authorized access for monitoring and maintenance, and tours if desired.

4.2 Hydraulic Analysis Results

Various hydraulic model scenarios were evaluated to estimate the hydraulic performance of the proposed wetland area during wet weather events and to guide the design process. See Section 3.2 Hydraulics for further discussion of the hydraulic modeling methodology. The first iteration of the conceptual design included having the two separate subtidal channels merging into one channel, with the merged channel maintaining a similar geometry as the separate channels, and then exiting through the berm. The hydraulic modeling indicated that this configuration will result in very high velocities of the merged flows. As such, various design iterations were considered and analyzed for several different channel widths and configurations with the objective of reducing the velocities of the merged flows, reducing the length of increased velocities, and restricting the flows in a manner that results in increased water surface elevations and thus greater amount of the storm water runoff inundating the low salt marsh area and being treated. The final design iteration for the connection with the Mission Bay open water is presented in the drawing for this PER and incorporates a tiered, or stepped, configuration that provides increased area that results in reduced velocities of the merged flows. The stepped design results in the majority of the flow having to travel up and over the step, which serves to increase the water surface elevations of the subtidal channel during wet weather flows and provides for improved water quality (i.e., increased treatment in the wetland area).

The results of the hydraulic modeling indicated that riprap revetment will be required to stabilize the subtidal channels at some locations, including at each outfall and at the connection with open water of Mission Bay. The stabilization of these areas cannot be avoided as these areas are locations where there will be a steep energy gradient line decrease. More specifically, flow out of the storm drain will be traveling at high velocities. Additionally, the lower the tide level in Mission Bay the greater the velocities will be at the connection, or interface, between the wetland system and bay, and for this reason stabilization is in the area of the channel that connects with the bay. The modeling results indicate that flow in the subtidal channels will be less than six feet per second, with the exception of each outfall and the connection with open water of Mission Bay.

4.3 Preliminary Opinion of Probable Construction Cost

To determine a cost estimate for this preliminary design, unit costs were derived from the City of San Diego Unit Price List and similar project cost estimates. The cost estimate for construction of the preliminary design is categorized by line item as shown in

Table 4-2.

Table 4-2. Preliminary Opinion of Probable Construction Cost

Item	Unit	Quantity Total	Unit Price	Cost
Riprap (2 Ton), Per SDD-104	CY	2,900	\$340.00	\$986,000
Import	CY	58,000	\$30.00	\$1,740,000
Low Salt Marsh	SF	150,700	\$2.80	\$421,960
Mid Salt Marsh	SF	68,700	\$2.80	\$192,360
Oyster Bag Stabilization	SF	127,900	\$5.50	\$703,450
Perimeter Fence (6-foot Chain Link)	LF	1,800	\$28.00	\$50,400
<i>Subtotal Construction Cost</i>				<i>\$4,094,170</i>
<i>Contingency (30% of Total Construction Cost)</i>				<i>\$1,228,251</i>
Total Construction Cost				\$5,322,400

The planning and design cost estimate is based on 40% of the total construction costs. Restoration must adhere to City standards for restoration as stated in the Biology Guidelines of the Land Development Code. A 120-day plant establishment period is required along with a 5-year maintenance and monitoring program. For planning purposes, the opinion of probable costs assumes that replanting of 25% of the marsh vegetation will be required during the 120-day plant establishment period, replanting of 10% of the marsh vegetation will be required after each of the first years of monitoring, and that 5% of the marsh vegetation will be required after the fourth year of monitoring. An environmental permitting cost has been incorporated based on 5% of the total construction costs. The total preliminary opinion of probable cost of the Cudahy Creek (Leisure Lagoon) Wetland Restoration preliminary design is shown in Table 4-3. Additional information on the opinion of probable cost is provided in Appendix C.

Table 4-3. Preliminary Opinion of Probable Cost

Item	Cost
Total Construction Cost	\$5,322,400
Planning and Design (40% of Construction Cost)	\$2,129,000
Environmental Permitting (5% of Construction Cost)	\$266,100
PEP, Maintenance & Monitoring	\$599,300
Total Cost	\$8,316,800

In the initial phase of this analysis, cost estimates were formulated based on data from 2021. The cumulative inflation rate can be estimated utilizing the California Construction Cost Index (CCCI). From February 2021 (CCCI = 7102) to June 2024 (CCCI = 9651), the index shows an approximately 35% increase in overall construction costs.

4.4 Preliminary Project Schedule

A preliminary project schedule of the Cudahy Creek (Leisure Lagoon) Wetland Restoration can be found in Appendix C.

5 Other Considerations As Appropriate

5.1 Feasibility Analysis of Constructability

This section presents information about construction such as the approach, material re-use options, equipment needs, and phasing. Each subject is discussed below.

5.1.1 Construction Approach

In order to construct the proposed Cudahy Creek restoration, it is ideal for conditions to be dry. During the dry season of the year (May through September) rain events and discharges at the existing outfall will be minimal. The equipment that may be utilized includes backhoes, barges, and possibly a clamshell grab dredger. To access the project site limits, barges will need to be utilized when constructing the west side of project (berm area and confluence of subtidal channel), since it is in the middle of Mission Bay. Furthermore, construction access may be from the shore via shared paths and shoreline. Equipment used on the shoreline can be stored/staged within the existing parking lot located north of the project limits and west of East Mission Bay Drive.

The quantity of soil to be imported is relatively large at approximately 58,000 cubic yards. This quantity will require at least 91 working days if the work is done as efficiently as possible.

5.1.2 Material Disposal/Re-use Options

An opportunity for material re-use is available in the coordination of adjacent wetland restoration projects in Mission Bay or in coordination with the Mission Bay Navigational Safety Dredging Project. The Rose Creek Wetland Restoration, De Anza Restoration of Shoreline, Cudahy Creek Wetland Restoration, Tecolote Creek Wetland Restoration, and North Fiesta Island Wetland Restoration projects could be grouped together under one or more contracts to allow for the contractor to strategically balance cut and fill volumes across all sites. The construction efficiency gained in this opportunity would also reduce total construction schedule and costs of all wetlands. North Fiesta Island Wetland Restoration project has a proposed surplus of 315,000 CY of material that is suitable for the Cudahy Creek project. The Mission Bay Navigational Safety project aims to remove sediment from the bay floor that has built up in navigable areas, redistributing it to other locations within the bay to enhance boating safety. The Cudahy Creek wetland restoration project could accommodate the transplantation of excavated material to support the ecological restoration effort.

5.1.3 Equipment Needs

The suite of equipment needed to perform construction of the wetland in the dry and wet conditions is estimated to be:

- Scrapers with a capacity of 30 cubic yards each (5);
- Excavators (4);
- Off-road trucks with a capacity of 16 to 18 cubic yards each (12);
- Barge (1);
- Front-end loaders (5); and
- Bulldozers (5).

5.1.4 Construction Access Points

Land-based construction equipment would access the site from East Mission Bay Drive. Water-based construction equipment would access the site from Fiesta Island. Equipment and materials could be staged in the adjacent parking lot to the north of the site, and a daily staging area adjacent to the site could be located to the west of the concrete pedestrian path to decrease conflicts between pedestrians and construction activities.

5.1.5 Post-Construction Access

At the conclusion of construction, it is important to limit access to the newly created and sensitive wetland area to promote the development of a healthy ecosystem and restrict degradation due to intrusion such as trampling. The placement of informative and cautionary signs and the installation of a fence along the boardwalk that borders the wetland perimeter will contribute to access restriction compliance and wetland conservation. This is an opportunity to educate the public on ongoing efforts and will increase environmental awareness.

5.1.6 Maintenance Requirements

Operations and maintenance will be required for the wetland. The most intensive actions may include:

- Trash removal
- Access control measures/Signage
- Weed removal from transitional habitat areas
- Channel maintenance
- SLR adaptive management

Inspection and maintenance of the wetland area should occur at regularly interval (e.g., monthly), primarily focused on trash removal (if present) and to observe the general health of vegetation, to ensure the habitat function is sustained at the highest level possible for the site. Annual or bi-annual inspections may be required and may include vegetation survey and assessment of sedimentation. Some sedimentation within the wetland is expected; however, it is anticipated that maintenance to remove the sediment will not be required (i.e., wetland is expected to function with the anticipated sediment from the watershed). The subtidal channels have been designed with a bottom width of 11 feet and top width of 50 feet to minimize the potential for sedimentation and to allow for a wide flow of flood conveyance in the event that some sedimentation occurs.

The statement that maintenance is anticipated to remove sediment is based on rough-order-of-magnitude preliminary sediment calculations. Assuming a total suspended solids (TSS) of 100 mg/L, which is a reasonable estimate of TSS in urban runoff, using the hydrology data presented in Section 3.1, and an annual rainfall of 10.5 inches (approximately the Lindberg Field average rainfall) the annual TSS load was calculated. Assuming a density of 100 lbs/cf (reasonable value for loose sandy materials), calculations indicate that 710 cf of sediment would be generated from the runoff. If all that sediment was deposited in the 3.7 acres of proposed low salt marsh wetland, it would take approximately 30 years to accumulate to a depth of 3 inches. It is estimated that approximately 1 foot of sediment accumulation would start to impact the function of the wetland vegetation and require maintenance.

A pre- and post-construction monitoring program may be required by the CCC to quantify changes to the site over time. The monitoring plan should be integrated into existing work at the Mission Bay Wetlands by local universities, and potentially coordinated with the regional monitoring program devised by the Science Advisory Panel for the Southern California Wetlands Recovery Project. Monitoring should occur for the lifetime of the project and include tidal elevations at several points in each marsh, water quality, and habitat condition and distribution.

Post-construction public access control measures will facilitate the maturation of a healthy ecosystem by limiting human disturbance within the newly constructed wetland area. Decreased interference with plant growth and ecosystem development will also limit maintenance needs throughout the prescribed monitoring period.

Issues with compromised habitat conditions, hydrology or sedimentation would need to be addressed through adaptive SLR management. Adaptive management may include minor grading, planting, and periodic thin-layer sediment augmentation to maintain appropriate tidal/land elevation relationships that support the target marsh habitat diversity.

5.2 Risk Assessment

Various risks are prevalent when undertaking a wetland restoration design process. This section explores the variety of risks to help shed light on the potential future challenges that may be encountered. By documenting the risks, and developing an understanding of common challenges, future pitfalls may be

avoided or minimized to achieve the best possible outcome. The multiple potential risks are summarized below.

A Risk Assessment Table was prepared based on three criteria: (1) probability of each risk occurring, (2) the potential impacts to cost, and (3) the potential impacts to time until project completion. Each risk was given a value of either very low, low, moderate, or high for each of the three risk assessment criteria, and a strategy and response action for each risk was formulated. A Risk Assessment Table containing all the information from the risk assessment is provided in Appendix D.

5.2.1 Land Ownership

The Cudahy Creek (Leisure Lagoon) Wetland Restoration is located within Mission Bay Park, in San Diego, CA. It is owned and maintained by the City of San Diego. As such, there are no known land ownership conflicts that may present risk to this project.

5.2.2 Utilities

A review of existing utilities was performed utilizing data from SanGIS, published by the City of San Diego Public Utilities Department and SANDAG, and as-builts from the City of San Diego. As a results of the review, it was found that no existing utility conflicts exist within the project area.

The contractor will be required to take due precautionary measures to protect any existing utilities or structures located at the work site. It is the contractor's responsibility to contact the owners of sewer, gas and electric, water, and storm drain outfall utilities or structures prior to any excavation for verification and location of utilities and notification of commencement of work.

5.2.3 Existing Soil Data

Soil data has not been explored at this time. Project grading will primarily consist of placing fill materials. The fill materials shall be verified to not be contaminated prior to being sourced for this project. The risk of associated with source materials being contaminated is associated with whatever project those materials are being generated at. Testing to confirm materials are appropriate shall be performed in order to reduce the risk to this project.

5.2.4 Proximity to Neighbors

The Cudahy Creek Wetland Restoration is located within east Mission Bay. It is surrounded on its western side by navigable waters. On its northern and southern border is the Mission Bay Park, and the East Mission Bay Drive is located on its eastern side. Creation of Cudahy wetland will not reduce public access within Mission Bay Park. However, construction activities have the potential to impact neighbors in a multitude of ways, including, but not limited to noise and vibration impacts.

Noise and vibration impacts have the potential to disrupt visitor, commercial, and residential activity throughout Mission Bay Park. This includes several surrounding park areas, including Fiesta Island, Tecolote Shores, Playa Pacifica Park, Mission Bay Park, De Anza Cove Park, Campland on the Bay, Crown Point Park,

Ski Beach Park, and Mission Bay waters, which are actively used for recreation. Commercial impacts could be felt by, for example, visitor supporting businesses, including the nearby San Diego Mission Bay Resort. Residential impacts could extend to the nearby Bay Park and Crown Point communities, and others.

5.2.5 Environmental Windows

Environmental constraints of endangered bird nesting seasons require that certain elements of the overall Project be phased or timed. This "project schedule" is an important part of the permits, and engineering contract documents (plans, specifications, and estimates for contractor bidding), as well as assurances to the resource agencies that the Project will be implemented without incurring unanticipated incidental impacts. If the project boundary is within 500 feet of sensitive bird populations, then breeding restrictions would limit construction from September 1st to February 15th. The closest know sensitive bird population is the California Least terns on Fiesta Island. Since Fiesta Island is located more than 500 feet from the project boundary, it is anticipated that work for this project could occur during the nesting season (mid-February through early-September) provided that there is a pre-construction survey and other standard precautions have been met.

5.2.6 Water Quality Concerns

Cudahy Creek Wetland Restoration is designed with the primary goal of complying with the Master Plan water quality improvements initiative. The first Mission Bay Master Plan (San Diego 1994) key recommendation is:

It is broadly recognized that the Park's economic and recreational future depends on the quality of the Bay's water. In response to fluctuating quality of the Bay waters, this Plan proposes a comprehensive set of measures involving state-of-the-art biological, mechanical, public education and recreation management programs. Biological measures include the establishment of salt-water marshes that can naturally filter pollutants as they enter the Bay through the creeks that drain the Bay's watershed...

A past Water Quality Control Study (Tetra Tech 1983) identified that the water quality problem largely stems from two issues:

- A nearly continuous input of pollutants from various point and nonpoint sources within the increasingly urbanized drainage areas inland from the bay.
- Flushing and circulation conditions which are generally inadequate to transport pollutants out of the Bay. As a result, pollutants can build up to undesirable levels.

The Project proposes to create and protect a wide range of natural habitat. The habitats proposed for wetland restoration include low marsh, mid marsh, and transitional habitat.

During construction activities, the project grading adjacent to and part of the Mission Bay has the potential to impact the water quality of the bay. Grading activities will be required to adhere to construction storm water BMP requirements with special provisions to be implemented to be protective of the bay, including

but not limited to installing and maintaining a silt curtain between the project and the open waters of the bays, construction sequencing (i.e., building berm first to act as a barrier), limiting the rate that is fill is placed on the berm, and conducting daily monitoring of TSS in the bay during construction activities.

5.2.7 Competing Interests

City Charter Section 55.2 proposes that the Mission Bay Park Improvements project include efforts to restore wetlands, wildlife habitat, and other environmental assets; preserve beneficial uses of the Improvement Zone by maintaining navigable water and eliminating navigational hazards; restore embankments and erosion control features; and to improve the conditions of the Improvement Zone for the benefit and enjoyment of residents and visitors.

The Cudahy Wetland Restoration project makes up one project of the wider Mission Bay Park Improvements. As such, the project is focused on certain aspects of the larger City Charter Section 55.2. The project is designed to provide the restoration of tidal wetlands, which balance the need for mitigation, water quality, flood control, aquatic recreation, and public safety. Currently, the project area is comprised of mudflat and shallow open water area that does not support recreational activities, such as swimming, fishing, rowing, or motor boating.

5.2.8 Sensitive Habitat

Nesting or roosting migratory birds has the potential to be a severe risk for project in the Mission Bay Area. This risk item has been estimated to have a low probability of occurrence and a moderate potential impact to the time until project completion. Related to bird nesting, all efforts should be taken to minimize or avoid impacts by planning construction activity outside of breeding season.

During construction, the presence of archeological or paleontological resources, rare plant species, and rare or endangered fish or wildlife may occur which would lead to potential delays during construction. The project proposes to place fill materials in areas currently identified as either open water or low-quality mudflat to create primarily low salt marsh wetland habitat with some transitional salt marsh wetland habitat as well as subtidal channels and mudflat area. Based on this, the project is anticipated to be beneficial related to sensitive habitat.

5.2.9 Sea Level Rise

Salt marsh restoration at Cudahy Creek must be developed considering Sea Level Rise (SLR), which is the local rate of SLR relative to the land. SLR primarily affects this project with its impact on wetland habitat distribution and functions. Based on the *Rewild Mission Bay Wetland Feasibility Study* (Everest, 2018), low salt marsh in the bay occurs in the elevation range of 0.3 to 2.3 ft (NGVD29). The project proposes low salt marsh at elevations between 0.9 and 1.1 ft (NGVD29). This will allow for SLR resilience of approximately 0.6 to 0.8 ft.

As directed by the City, this report analyzes the risk SLR poses to the site through the Year 2100. Two SLR projections (3.6 feet and 7.0 feet) were selected for Year 2100 that represent major thresholds for the

project. These thresholds represent the 17% probability and 0.5% probability scenarios and are driven by coastal flooding that is expected to increase (progress inland) with a 100-year storm event in conjunction with SLR. There is a low probability that SLR could exceed 7.0 feet by the end of the century, but the range of scenarios presented here capture important impact thresholds for Cudahy Creek regardless of when they occur. Future habitat distribution compared to the original habitat design is significantly affected by SLR. Future impacts from an SLR increase of 3.6 feet and 7 feet are summarized below.

- **3.6 feet (110 cm) SLR:** most of the project would be subject to tidal inundation during high tides after restoration. Under this scenario the restored salt marsh habitat will likely transform with less low marsh, and more mudflat, with subtidal habitat. Without raising the elevation of the site by filling or implementing adaptation measures, the site would effectively become mudflat with tidal channels. The exception is the transitional and mid marsh habitat area that becomes low marsh.
- **7.0 feet (213 cm) SLR:** under this SLR scenario, the wetlands would be nearly all subtidal and mudflat habitat area. Without raising the elevation of the site by filling or implementing adaptation measures, the site would effectively become mudflat with tidal channels.

Table 5-1 below shows the changes (in acres) to habitat areas with each SLR scenarios for the proposed habitat of the Project.

Table 5-1. Change to Habitat Areas in Acres with 3.6 and 7.0 Feet of SLR

Proposed Habitats	Designed Acreage	Habitat with 3.6 ft SLR	Habitat with 7.0 ft SLR
Subtidal	4.0	4.0	4.0
Mudflat	0	3.7	5.7
Low marsh	3.7	2.0	0
Mid marsh	1.5	0	0
High marsh	0	0	0
Transitional	0.3	0	0
Disturbed Habitat/Upland	0.2	0	0
Disturbed Salt Marsh	0	0	0
Beach	0	0	0
Riprap	0.2	0.2	0.2
TOTAL AREA	9.9	9.9	9.9

Storm events may result in the deposition of sediment to keep up with or at least offset (i.e., delay) impacts from SLR. The amount of sediment from storm event will be dependent on a number of factors, include the severity of storm events, erosion potential in watershed, the composition, or gradation, of eroded materials, and tide level during the storm events. The amount of sediment deposition will not be known until after the low salt marsh wetland is well established and after several years of larger events (e.g., 2-year and 5-year storm events).

When SLR causes significant habitat changes in the marsh, the site can be adapted by:

- Reconfiguring and/or raising the marsh plains above future high internal marsh water levels through thin layer sediment additions (e.g., the pilot project at Seal Beach Naval Weapons Station in 2016). This will allow for mudflat and vegetated marsh habitat to persist; and/or

While it is possible that these adaptation strategies may need to be implemented in the near-term at some time between 2050 and 2100, they may also need to be repeated multiple times in the long-term after 2100 as sea levels rise in the future. Adaptation measures such as the ones listed above will be necessary if the vision is to provide vegetated marsh habitat at Cudahy Creek into perpetuity.

5.2.10 Permitting

The project will need to receive approval from multiple resource permitting agencies, and the possibility of project delays during approval could occur, which would result in an increased project schedule or require new mitigations. As a result of changing regulations and standards, the introduction of new guidelines may occur, which would lead to additional permitting costs and time. A Site Development Permit, along with other environmental permits, will be pursued for the overall Mission Bay Park PEIR. See Section 5.4 Environmental Consideration and Permits for further discussion of the permitting.

5.3 Project Conflict Coordination and Evaluation

One potential conflict for this project is related to the competing interest between wetland creation and recreational use of the area within Mission Bay. Since the project is proposing a portion of Mission Bay be converted to wetland, there is a potential to impact the recreational value of Mission Bay. However, the Cudahy Creek Wetland Restoration Project proposes wetland within a relatively small portion of the overall Mission Bay Park, and the proposed wetland area is limited to the Cudahy Creek Cove area. The interface between the wetland and the open water of Mission Bay (identified as North Pacific Passage) has been designed to correlate with the curvature of the passage channel, which will allow for aquatic recreation to continue in the passage channel of the bay while not creating a public safety hazard. The area proposed for wetland restoration within the cove is primarily in areas currently occupied by mudflat type bottoms and typically with steep banks and little to no beach area. As such, the impact to aquatic recreation within the cove area by the proposed wetland restoration will be minimal. Additionally, the water quality benefits provided by the proposed wetland includes filtration of water during each tide cycle, which in turn will improve water quality and enhance aquatic recreation in the remaining open water areas of Mission Bay, especially during the summer month when aquatic recreation is at the highest level.

Currently (at the time of the authoring of this report) there are no Capital Improvement Program (CIP) projects relevant to the Cudahy Creek Wetland Restoration project area. The Mission Bay Park Masterplan identifies the Cudahy Creek area as only for potential wetland restoration/preservation. There are no known conflicts with other adjacent City of San Diego projects. Additionally, there are no utilities within the project area. The main potential this project has for future CIP project conflicts would be any improvements to the two storm drain outlets into the project area. The design of the main hydraulic conveyance system of the project, the two subtidal channels, is based on the current (at the time of the authoring of this report)

geometry and configuration of the two outfalls, including a dual 72-inch RCP north outfall and a triple-cell six feet (width) by five feet (height) RCB south outfall. If a future CIP project proposes any changes to either outfall, coordination will need to take place with this project to determine how to accommodate the proposed changes.

Another conflict that could potentially occur is with the City of San Diego’s Beach Area Construction Moratorium. Based on this moratorium, the days preceding and immediately following Memorial Day, Fourth of July and Labor Day holidays are not to be scheduled for non-emergency construction activities. This may affect scheduling of the overall project, however it is anticipated to have a minimal affect.

Additionally, it should be noted that multiple other projects are included as part of the overall Mission Bay Program EIR. These other projects have a potential to combine or conflict with the Cudahy Creek Wetland Restoration, depending on the timeline for each project.

5.3.1 Wetland Restoration

As a part of the Mission Bay Park PEIR, multiple wetland restoration projects are proposed throughout the Bay. Wetland restoration is currently proposed at Cudahy Creek Cove, Rose Creek, De Anza Point, and Tecolote Creek with the addition of a culvert or channel under the Fiesta Island Causeway.

Construction timing of all wetland restoration projects in Mission Bay is currently undefined. There is a potential for construction of such projects to be complementary to one another. Beneficial reuse of excavated dredge material could be distributed across sites in place of import material to maintain sediment on-site and reduce construction costs across several restoration projects. Additionally, mobilization and demobilization costs increase construction costs; phasing of construction of wetland restoration projects could capitalize on the availability and proximity of construction equipment, materials, and crew. Wetland restoration projects could potentially be grouped under one construction contract, allowing the contractor to plan efficient use of construction equipment, materials, and crew.

5.4 Environmental Considerations and Permits

Environmental permits required to construct the Cudahy Creek Wetland are summarized in, but not limited to Table 5-2.

Table 5-2. Environmental Permit Requirements

Agency	Permit
Federal	
U.S. Army Corps of Engineers (USACE)	<ul style="list-style-type: none"> Permit under Section 404 of the Clean Water Act, 33 USC Section 1344 (Regional General Permit) Section 10 of the River and Harbors Act of 1899, 33 USC Section 403

Agency	Permit
National Marine Fisheries Service (NMFS)	<ul style="list-style-type: none"> • Issue Record of Decision (ROD) • Fish and Wildlife Coordination Act, 16 USC Sections 661-666
State Historic Preservation Officer/Tribal Historic Preservation Office	<ul style="list-style-type: none"> • Magnuson-Stevens Fishery Conservation and Management Act, as amended 1996 (Public Law 104-267)
U.S. Fish and Wildlife Service (USFW)	<ul style="list-style-type: none"> • National Historic Preservation Act of 1966 (NHPA), Section 106 Consultation with SHPO/THPO (36 CFR Part 800) • Endangered Species Act, 16 USC Sections 1531-1544 Section 7 Consultation with the federal lead agency (i.e., USACE) • Programmatic Biological Opinion
State	
California Coastal Commission (CCC)	<ul style="list-style-type: none"> • Coastal Development Permit • Consistency Certification, Section 30600(a) of the California Coastal Act, or Waiver of Federal Consistency Provisions
California Department of Fish and Wildlife (CDFW)	<ul style="list-style-type: none"> • Streambed Alteration Agreement, Section 1602 of the California Fish and Game Code • California Endangered Species Act Section 2081 Incidental Take Permit • Programmatic Biological Opinion and Biological Assessment
Regional Water Quality Control Board (RWQCB)	<ul style="list-style-type: none"> • Water Quality Certification under Section 401 of the Clean Water Act • General Waste Discharge Requirements
Regional/Local	
San Diego Air Pollution Control District (APCD) City of San Diego	<ul style="list-style-type: none"> • Authority to Construct/Permit to Operate for any dredge
City of San Diego	<ul style="list-style-type: none"> • Site Development Permit

As a part of the Mission Bay Improvements Plan, the City is seeking to streamline state and federal resource agency approval for all future projects, including Cudahy Creek Wetland Restoration. This work includes but is not limited to preparation and submission of applications for regulatory permits to the U.S. Army Corps of Engineers (USACE), pursuant to Section 404 of the federal Clean Water Act (CWA) and Section 10 of the Rivers and Harbors Act; California Regional Water Quality Control Board (RWQCB), pursuant to Section 401 of the federal CWA; U.S. Fish and Wildlife Service (USFW) Programmatic Biological Opinion; and California Department of Fish and Wildlife (CDFW), pursuant to the California Fish and Game Code (Section 1600). Additionally, permitting support and strategy for the California Coastal Commission (CCC) pursuant to the California Coastal Act and Coastal Zone Management Act is in progress at the authoring of this report.

Pursuit of USACE Section 404 CWA programmatic permit is anticipated to be applied for as a Regional General Permit (RGP) to authorize the implementation of multiple projects within Mission Bay. An RGP can authorize a category or categories of activities, such as the Mission Bay Park Improvements, in a specific geographical region for activities that are similar in nature and cause only minimal individual and cumulative environmental impacts.

In pursuit of a U.S. Fish and Wildlife Service (USFW) Programmatic Biological Opinion, a Biological Assessment (BA), which is a modified version of a Biological Technical Report (BTR), is required in accordance with Section 7 of the Endangered Species Act (ESA). The BA is focused on project impacts on and restoration benefits for California least tern, western snowy plover, and other federally listed species, including marine species, which have the potential to occur within the project area.

In pursuit of a RWQCB programmatic 401 Water Quality Certification, an application will be required as well as RWQCB issued General Waste Discharge Requirements (WDRs) for authorization of Mission Bay Park Improvements.

Resource agency-imposed restrictions play a strong role in construction costs and duration. During discussions with resource agencies, permit restrictions will be negotiated, including but not limited to:

- Hours of Operations
- Noise Control
- Light Control
- Dust Control
- Fueling
- Site Access
- Storage and Staging
- Impacts to Habitat and Sensitive Species

Regarding the above topics, the City should strive for the following in order to maintain flexibility of construction methods:

- 6-day work weeks
- Hours of operation from 7AM to 6PM with occasional night work, as necessary
- Fueling and equipment maintenance permitted on site
- Land-based and water-based site access
- Wide environmental window
 - The timing of construction in sensitive areas may also be affected by the patterns of nesting and breeding birds. Typically, the nesting season window is mid-February through early-September, which coincides with a large portion of the dry season. However, it may be argued that minimal sensitive habitat is present at all project sites, due to the high level of shoreline development in Mission Bay.
- Flexible construction access and staging areas
 - Multiple construction access and staging areas allow various approaches to be conceived by contractors to increase competition during bidding.

- Staging areas within or close in proximity to the construction area reduces construction duration and cost.

5.5 City Professional Standards and Mission Bay Masterplan Consistency

In regard to City professional standards, all hydrologic and hydraulic design and analyses were completed under the guidance of the City of San Diego Drainage Design Manual, dated January 2017.

Additionally, this project is consistent with the existing Mission Bay Park Master Plan. The Mission Bay Park Master Plan Update, adopted on August 2, 1994 and amended on July 9, 2002, identifies the Cudahy Creek wetland area as one of three locations for restoration of tidal wetlands where the ultimate wetland area should be derived from balancing mitigation, water quality, flood control, aquatic recreation, and public safety (City of San Diego 2002). A preliminary analysis of the constraints and opportunities to provide wetland treatment at Cudahy Creek was prepared by Merkel & Associates, Inc. (Merkel 2003). The 2003 Merkel & Associates, Inc. preliminary analysis included the preparation of a cursory level, conceptual design for salt water marsh within the cove. Both referenced documents along with ongoing coordination with City Planning Department staff were utilized to determine the basis of design for the Cudahy Creek Cove wetland area. Concept development, design, and permitting of Cudahy Creek Wetland Restoration must comply with City standards and the Mission Bay Park Masterplan (City of San Diego 2002). An inventory of relevant standards, potential conflicts, and potential resolutions to such conflicts, is provided in Table 5-3.

Table 5-3. Inventory of Relevant Standards

Source	Standards and Recommendations	Compliance/ Potential Conflict	Implementation/ Solution
Mission Bay Park Master Plan	It is broadly recognized that the Park's economic and recreational future depends on the quality of the Bay's water. In response to fluctuating quality of the Bay waters, this Plan proposes a comprehensive set of measures involving state-of-the-art biological, mechanical, public education, and recreation management programs.	Cudahy Creek Wetland Restoration preliminary design is developed with the general goal of improving or maintaining water quality.	Improvements - Wetland Habitat
	The turf and beach areas along the Park's shorelines support the most intensive public recreational activity in Mission Bay. These areas draw users from throughout the San Diego region. With the County's population on the rise, the capacity of the park to accommodate this activity must be commensurately increased.	Cudahy Creek Wetland Restoration preliminary design is developed with the general goal of improving or maintaining public	Improvements - Natural Recreation

Source	Standards and Recommendations	Compliance/ Potential Conflict	Implementation/ Solution
Mission Bay Park Master Plan (Continued)	<p>The rise of environmental awareness in recent decades has been paralleled by an increase in the desire for more natural recreation venues. The telephone survey conducted as part of the Master Plan Update revealed that a majority of San Diego residents would like to experience parts of Mission Bay in a more natural condition.</p>	<p>recreational activity. Cudahy Creek Wetland Restoration preliminary design is developed with the general goal of improving or maintaining the natural condition of Mission Bay.</p>	<p>Improvements - Subtidal Habitat - Low Marsh Habitat - Mid Marsh Habitat - Transitional Habitat - Oyster Habitat</p>
	<p>In response to an extraordinary level of public demand for preservation and enhancement of natural resources, this Plan includes a number of proposals aimed at improving the Park's wildlife habitats.</p>	<p>Cudahy Creek Wetland Restoration preliminary design is developed with the general goal of improving or maintaining the natural condition of Mission Bay.</p>	<p>Improvements - Subtidal Habitat - Low Marsh Habitat - Mid Marsh Habitat - Transitional Habitat - Oyster Habitat</p>
	<p>Pg. 82 – Mission Bay Park should be planned, designed, and managed for long-term environmental health. The highest water quality; sustained bio-diversity; ongoing education and research; and the reduction of traffic noise, and air pollution should all be priorities. The Park's natural resources should be conserved and enhanced not only to reflect environmental values, but also for aesthetic and recreation benefits.</p>	<p>Cudahy Creek Wetland Restoration preliminary design is developed with the goal of improving environmental conditions for Mission Bay Park.</p>	<p>Improvements - Water Quality - Subtidal Habitat - Low Marsh Habitat - Mid Marsh Habitat - Transitional Habitat - Oyster Habitat - Natural Recreation</p>
	<p>Pg. 90 - ...the creation of wet-lands in the Park should be pursued as part of a comprehensive program to improve the quality of the Bay waters.</p>	<p>Cudahy Creek Wetland Restoration preliminary design is developed with the general goal of improving or</p>	<p>Improvements - Wetland Habitat</p>

Source	Standards and Recommendations	Compliance/ Potential Conflict	Implementation/ Solution
		maintaining water quality.	
2018 City CADD Standards	Project plans to comply with The City of San Diego Storm Water Standards and the MS4 Permit.	Project plans to comply with City standards.	No conflict.
City Stormwater Guidelines	The City uses Bentley MicroStation as it's basic CADD graphics engine, for engineering design and drawing production. If approved by the City, Design Consultants may use other industry standard CADD systems, such as AutoCAD, to produce hard copy or PDF files which can be transmitted appropriately to the Project Managers as submittals. However, for compatibility reasons, all electronic CADD file submittals must be created in MicroStation or approved CADD system using City specified seed files that will be uploaded into the City's CADD file management system and shall conform to the requirements set forth in these standards (https://www.sandiego.gov/publicworks/edocref/drawings) .	Submit final electronic CADD files in MicroStation.	No conflict.

5.6 ADA and Title 24

The Americans with Disabilities Act (ADA) of 1990 is a civil rights law prohibiting discrimination against individuals with disabilities. With respect to Cudahy Creek Wetland Restoration, ADA requirements pertain to the Class II shared path adjacent to the project shoreline during construction. As result detour signs and possibly a temporary path shall be implemented for cyclists and pedestrians.

Title 24 is a California Building Standards Code establishing requirements for “energy conservation, green design, construction and maintenance, fire and life safety, and accessibility” of a building’s “structural, mechanical, electrical, and plumbing systems.” No buildings are proposed as a part of the Cudahy Wetland Restoration and, therefore, Title 24 requirements are not applicable.

6 References

- Alexander, Martin. 1977. Introduction to Soil Microbiology. Krieger Publishing Company, Malabar Florida. 1977
- Everest, California State Coastal Conservancy, San Diego Audubon Society, U.S. Fish and Wildlife Service, 2018. *ReWild Mission Bay: Wetlands Restoration Feasibility Study Report*. September 2018.
- IPCC, 2013: Climate Change 2013: The Physical Science Basis. Contribution of Working Group I to the Fifth Assessment Report of the Intergovernmental Panel on Climate Change [Stocker, T.F., D. Qin, G.-K. Plattner, M. Tignor, S.K. Allen, J. Boschung, A. Nauels, Y. Xia, V. Bex and P.M. Midgley (eds.)]. Cambridge University Press, Cambridge, United Kingdom and New York, NY, USA, 1535 pp.
- IPCC, 2014: Climate Change 2014: Mitigation of Climate Change. Working Group III Contribution to the Fifth Assessment Report of the Intergovernmental Panel on Climate Change [Edenhofer et al.]. Cambridge University Press, Cambridge, United Kingdom and New York, NY, USA, 175 pp.
- Merkel & Associates, Inc. 2003. *Cudahy Creek Region of Mission Bay Wetland Treatment Marsh Design Direction Issue Paper, Technical Memorandum #1*, prepared for the City of San Diego, Public Buildings and Parks, dated February 2003.
- Merkel & Associates, Inc. 2013. Mission Bay Park Eelgrass Inventory and Bathymetric Change Analysis 1988, 1992, 1997, 2001, 2007, and 2013, prepared for the City of San Diego Publics Works Department, E&CP, AEP Divisions. 2013.
- Moffatt & Nichol (M&N). 2019. Draft Mission Bay Hydrology Study. Mission Bay PEIR. April 5, 2019.
- Ocean Protection Council (OPC). 2017. Rising Seas in California. An Update on Sea Level Rise Science. April 2017.
- OPC. 2018. State of California Sea Level Rise Guidance.
- Oyster Recovery Partnership. "Water Quality Improvement". (<https://oysterrecovery.org/water-quality-improvement>, accessed April 2019). Accessed April 2019.
- Project Clean Water (PCW). 2020. Mission Bay/La Jolla WMA. www.projectcleanwater.org/watersheds/mission-bay-la-jolla-wma/.
- San Diego (City of San Diego). 1994, Amended July 9, 2002. "*Mission Bay Park – Master Plan Update*". August 1994
- San Diego (City of San Diego). 2013. "*Watershed Asset Management Plan*", Appendix C, Mission Bay Watershed. July 2013.

San Diego (City of San Diego). 2017. "Transportation & Storm Water Design Manual, Drainage Design Manual", dated January 2017.

San Diego (City of San Diego). 2018. "*Storm Water Standards*" dated October 1, 2018.

San Diego (City of San Diego). 2019. Sea Level Rise Vulnerability Assessment. July 2019.

Tetra Tech. 1983. *Water Quality Control Studies – Mission Bay Park*. Prepared for City of San Diego. March 1983.

The Water Environment & Reuse Foundation (WERF). 2017. Final Report, International Stormwater BMP Database, 2016 Summary Statistics. 2017.

Appendix A. Technical Support Documents



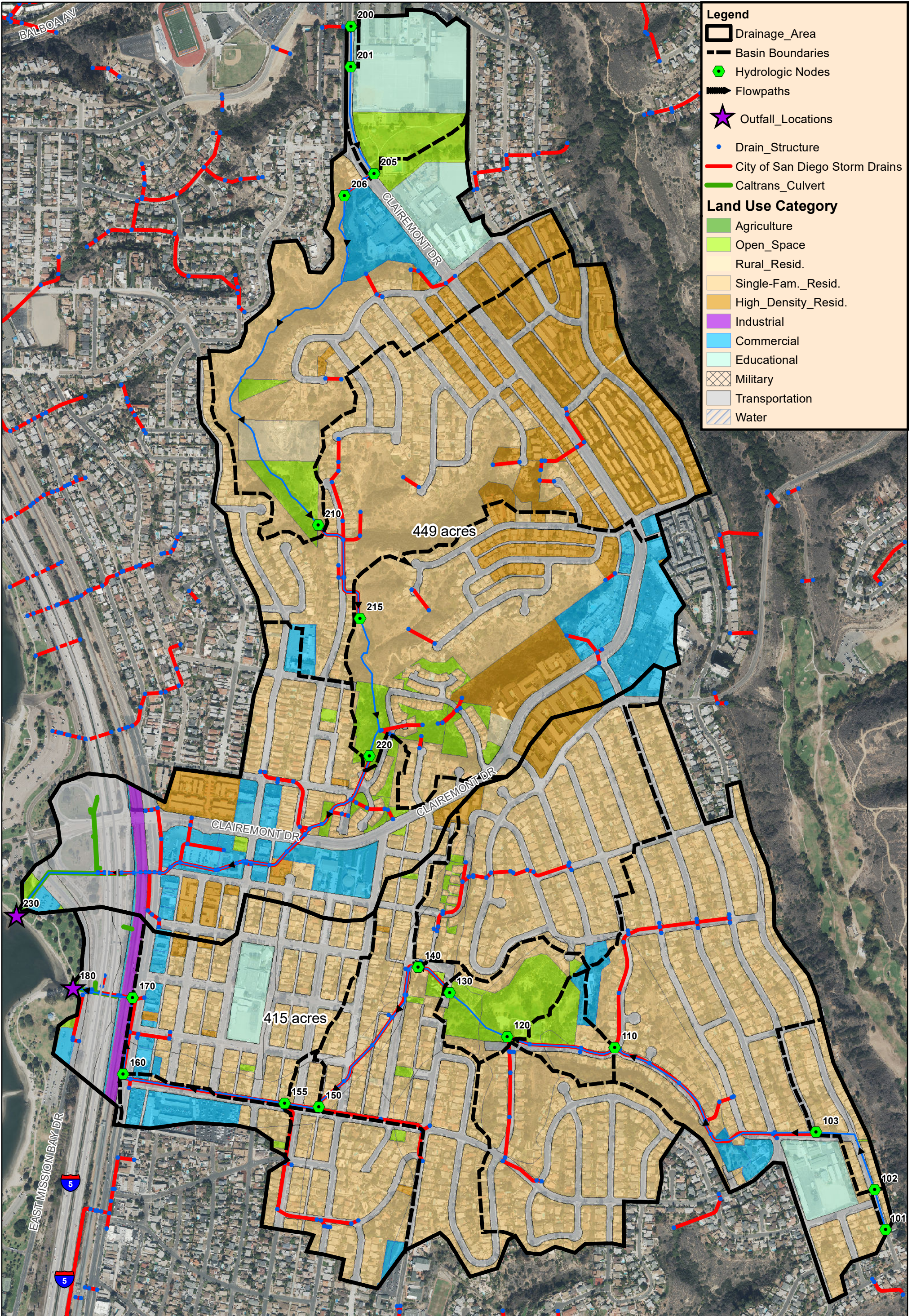

C:\RICK\Projects\IC_SD_T118097_MissionBay\PEIR\GIS\Exhibits\Hydrology\18097_Hydrology_Exhibits_CudahyCk.mxd

Cudahy Creek North Drainage Land Use

Composite C-Value

0.699

Area (ac)

449

Area (mi2)

0.70

Row Labels	Sum of Area_ac	Max of C-Value
Commercial-C	14.30	0.85
Commercial-D	26.92	0.85
Educational-D	25.62	0.85
High_Density_Resid.-C	52.50	0.7
High_Density_Resid.-D	31.91	0.7
Industrial-D	2.35	0.95
Open_Space-C	0.61	0.3
Open_Space-D	27.26	0.35
Rural_Resid.-C	0.57	0.45
Rural_Resid.-D	5.39	0.45
Single-Fam._Resid.-C	33.83	0.55
Single-Fam._Resid.-D	129.36	0.55
Transportation-C	33.04	0.95
Transportation-D	64.91	0.95
(blank)		
Grand Total	448.56	0.95

Cudahy Creek South Drainage Land Use

Composite C-Value

0.680

Area (ac)
415.1
Area (mi2)
0.65

Row Labels	Sum of Area_ac	Max of C-Value
Commercial-C	3.05	0.85
Commercial-D	7.53	0.85
Educational-D	4.94	0.85
High_Density_Resid.-C	3.78	0.7
High_Density_Resid.-D	1.42	0.7
Industrial-D	2.09	0.95
Open_Space-C	0.34	0.3
Open_Space-D	15.73	0.35
Rural_Resid.-C	0.00	0.45
Rural_Resid.-D	0.17	0.45
Single-Fam._Resid.-C	139.19	0.55
Single-Fam._Resid.-D	97.36	0.55
Transportation-C	53.41	0.95
Transportation-D	53.30	0.95
Educational-C	6.33	0.85
Single-Fam._Resid.-A	9.21	0.55
Rural_Resid.-A	0.05	0.45
Commercial-A	6.14	0.85
Water-D	0.01	1
Industrial-A	1.26	0.95
Transportation-A	9.78	0.95
(blank)		
Grand Total	415.09	1

Cudahy North Hydrograph Calculations

Tc =	23	min		City of San Diego
			Ref. 1:	Drainage Design Manual (Jan. 2017)
C =	0.699			Chapter 6, San Diego
Area =	448.6	ac	Ref. 2:	County Hydrology Manual (June 2003)
Qp =	723.1	cfs		

N	PN (inches)	QN (cfs)	Time (hours)	I (in/hr)	Time (min)
-	0.000	0.0	0	0	0
15	0.066	54.0	0.370	0.172	22.0
14	0.069	56.4	0.750	0.180	45.0
12	0.076	62.3	1.130	0.199	68.0
11	0.081	65.9	1.520	0.210	91.0
9	0.092	75.1	1.900	0.240	114.0
8	0.092	75.2	2.280	0.240	137.0
6	0.113	92.6	2.670	0.295	160.0
5	0.138	113.1	3.050	0.361	183.0
3	0.206	168.2	3.430	0.536	206.0
2	0.303	247.6	3.820	0.790	229.0
1	0.884	723.1	4.200	2.306	252.0
4	0.162	132.3	4.580	0.422	275.0
7	0.099	81.2	4.970	0.259	298.0
10	0.086	70.1	5.350	0.224	321.0
13	0.072	59.2	5.730	0.189	344.0
-	0.000	0.0	6.120	0.189	367.0

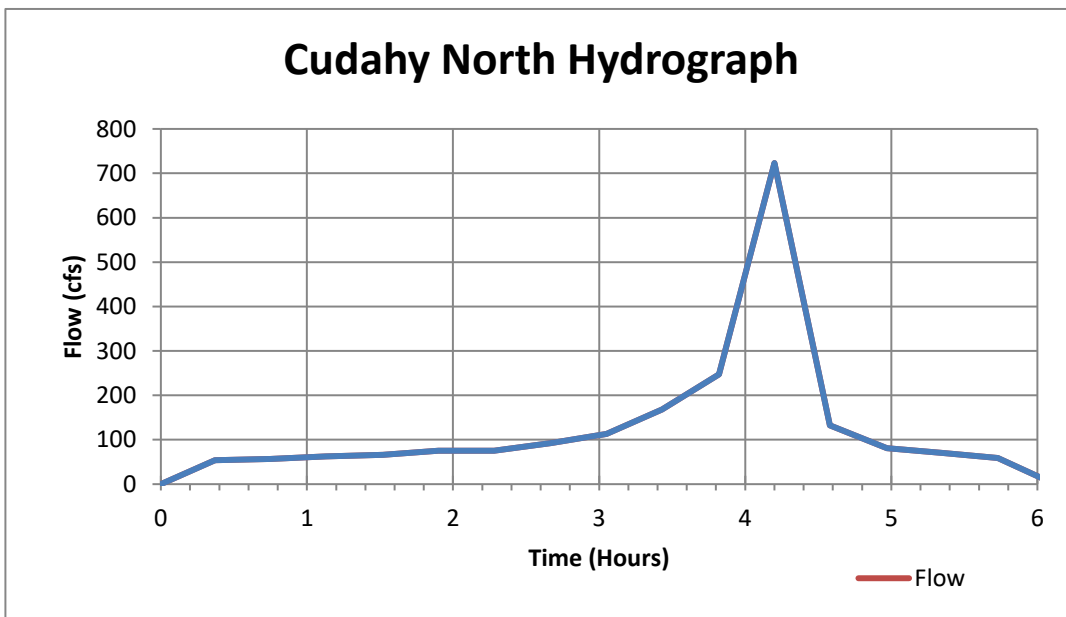

Cudahy South Hydrograph Calculations

Tc =	13	min		City of San Diego
			Ref. 1:	Drainage Design Manual (Jan. 2017)
C =	0.68			Chapter 6, San Diego
Area =	415.1	ac	Ref. 2:	County Hydrology Manual (June 2003)
Qp =	870.3	cfs		

N	PN (inches)	QN (cfs)	Time (hours)	I (in/hr)	Time (min)
-	0.000	0.0	0	0	0
27	0.037	47.6	0.220	0.169	13.0
26	0.037	48.8	0.430	0.173	26.0
24	0.039	51.3	0.650	0.182	39.0
23	0.040	52.7	0.870	0.187	52.0
21	0.043	55.8	1.080	0.198	65.0
20	0.044	57.6	1.300	0.204	78.0
18	0.047	61.6	1.520	0.218	91.0
17	0.049	63.8	1.730	0.226	104.0
15	0.053	69.2	1.950	0.245	117.0
14	0.051	66.8	2.170	0.237	130.0
12	0.056	73.0	2.380	0.259	143.0
11	0.059	77.5	2.600	0.275	156.0
9	0.075	97.6	2.820	0.346	169.0
8	0.081	105.5	3.030	0.374	182.0
6	0.098	127.8	3.250	0.453	195.0
5	0.115	149.2	3.470	0.528	208.0
3	0.175	228.0	3.680	0.808	221.0
2	0.268	348.8	3.900	1.236	234.0
1	0.668	870.3	4.120	3.083	247.0
4	0.136	176.736	4.330	0.626	260.0
7	0.088	115.256	4.550	0.408	273.0
10	0.065	84.704	4.770	0.300	286.0
13	0.053	69.166	4.980	0.245	299.0
16	0.051	66.360	5.200	0.235	312.0
19	0.046	59.482	5.420	0.211	325.0
22	0.042	54.204	5.630	0.192	338.0
25	0.038	49.998	5.850	0.177	351.0
-	0.000	0.000	6.070	0.177	364.0

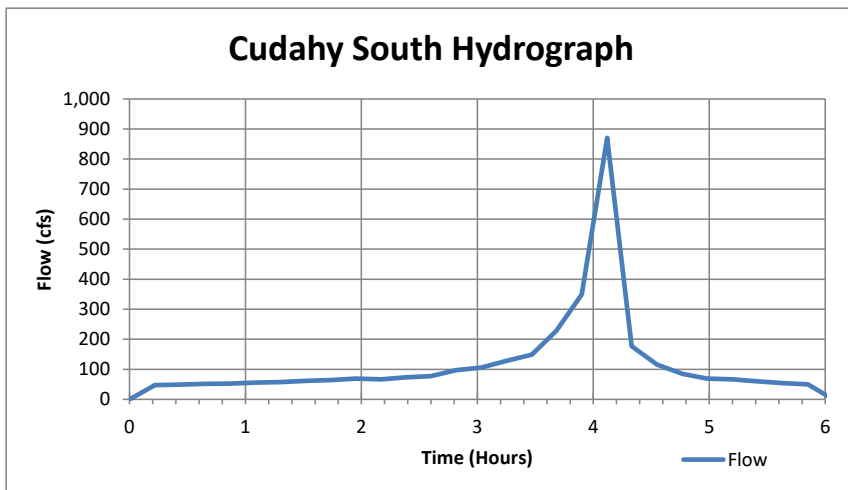

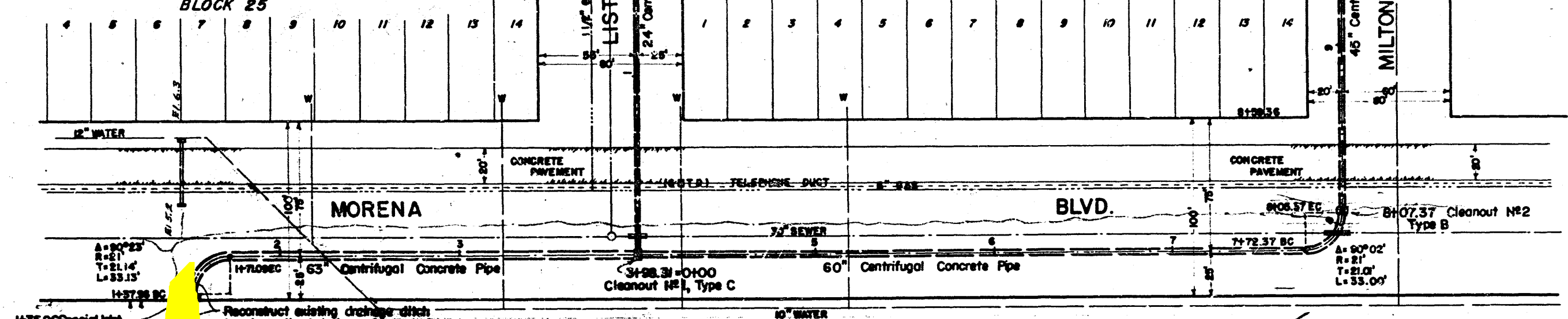
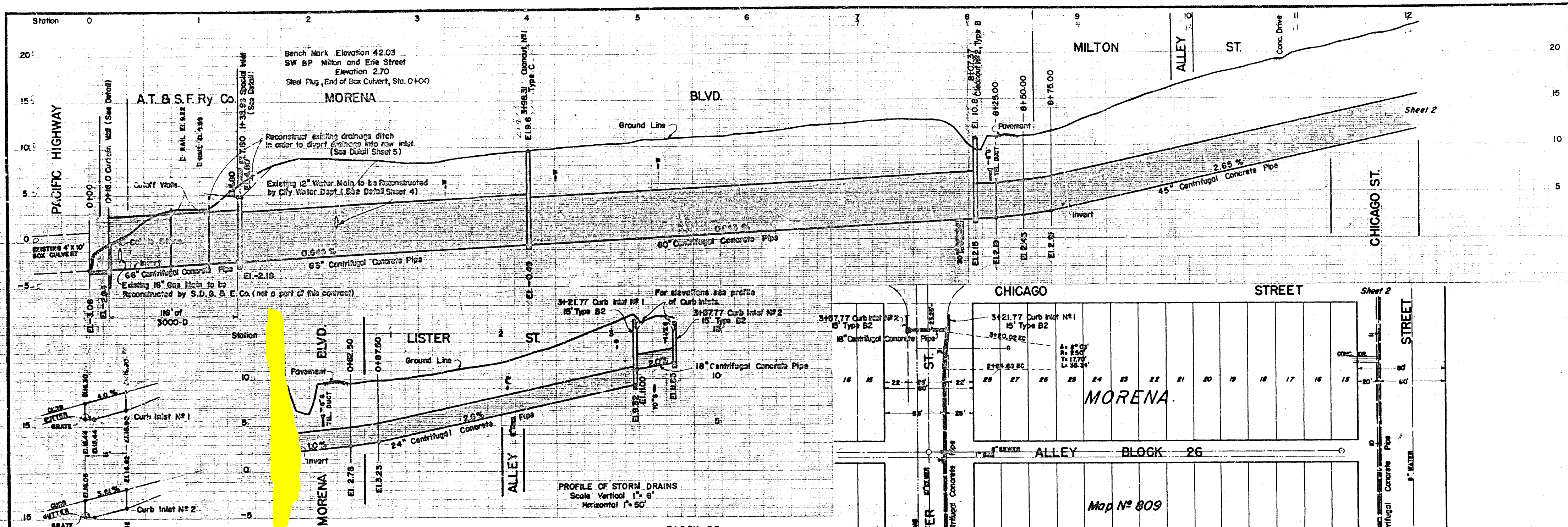

PROFILE OF CURB INLETS No 1 and No 2
SCALE: VERTICAL 1" = 3'
HORIZONTAL 1" = 20'

WORK TO BE DONE

The improvement consists of the following work to be done in accordance with these plans and the specifications hereto attached:

The construction of Concrete Pipe Storm Drain and Connections as shown on these plans thus:

The construction of Storm Drain Cleanouts and Curb Inlets of types and sizes as noted on these plans.

The construction of Concrete Sewer Encasements, Pipe Plugs, Headwalls and other appurtenances as detailed on these plans.

The removal and restoration of portions of the existing curbs, surfacing and pavement as may be required by the new installations.

The resurfacing of the portions of the existing pavement as shown cross-hatched on these plans.

The reconstruction of existing water main and service as detailed and noted on these plans.

LEGEND-EXISTING FACILITIES

- Curb Line
- Sewer Main and Manhole
- Sewer Lateral
- Water Main
- Water Service
- Gas Main
- Gas Service
- Telephone Conduit
- Culvert
- Edge of Pavement
- Telephone or Power Pole
- Tree

NOTES

All centrifugal concrete pipe shall have "D-Load" classification of 1250-D or more except where noted otherwise on these plans. Use standard beveled end joints around short radius curves. The location and elevation of underground installations of water, sewer, gas, and telephone lines as shown on these plans, are approximate only.

REFERENCE DRAWINGS

- 1509-D to 1316-D Sanitary Sewers
- 8370-L to 8377-L Improvements in
- Clairmont Heights Unit No 1.

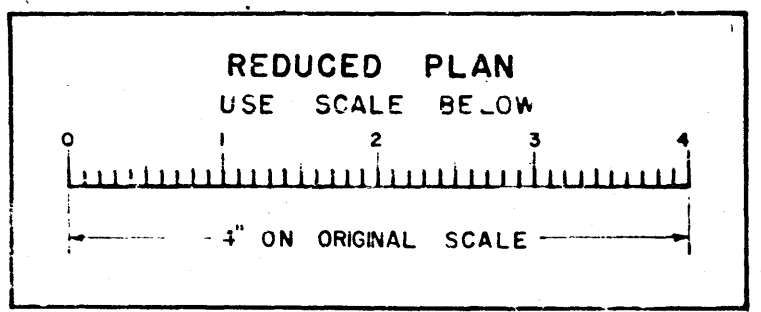

Remove existing cobblestone flume and construct concrete apron. (See Detail Sheet 5)

CITY DATUM
ADD 6.119 FEET
TO CONVERT TO
MEAN SEA LEVEL

STANDARD DRAWINGS

- Cleanout Cover & Frame 302-S-B
- Type B2 Curb Inlet 304-S-B
- Type G Curb Inlet 306-S-B
- Type A2 Curb Inlet 307-S-B
- Rounded Pipe Ends of Structures 309-S-B
- Type F to H Cleanouts 310-S-B
- Sewer Encasement 311-S-B
- Cutoff Walls 106-S-B
- Type G Curb 9-S-B

CITY CONTRACT

SHEET 1 CITY OF SAN DIEGO ENGINEERING DEPARTMENT 5 SHEETS

Plans for the construction of
BAY PARK VILLAGE STORM DRAIN in Morena Blvd.,
Lister St., Milton St., Frankfort St., Illian St., and A.T. & S.F.
Ry Co. Right of Way

APPROVED: *[Signature]* DATE 2/17/52
CITY ENGINEER
SCALE NOTED

DRAWN BY: CRL FEB. 1952
CHECKED BY: 2067, 2180
FIELD BOOKS

DRAWING NUMBER
MICROFILMED
9355-L

CONSTRUCTION RECORD W. O. No. 20897

CONTRACTOR Pace INSPECTOR Kassler
DATE STARTED 5-26-52 REVISIONS None
DATE COMPLETED 12-8-52

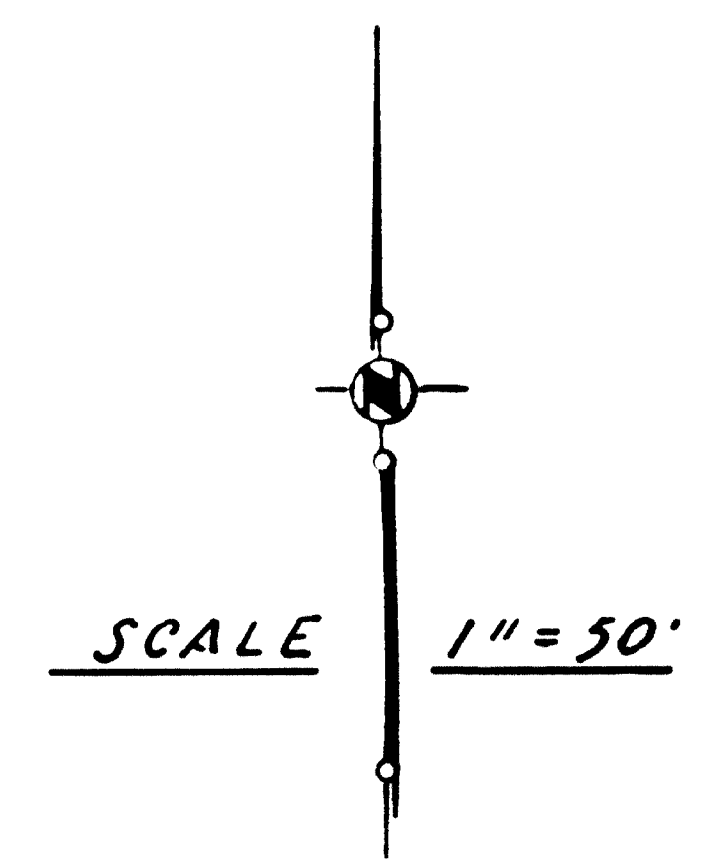
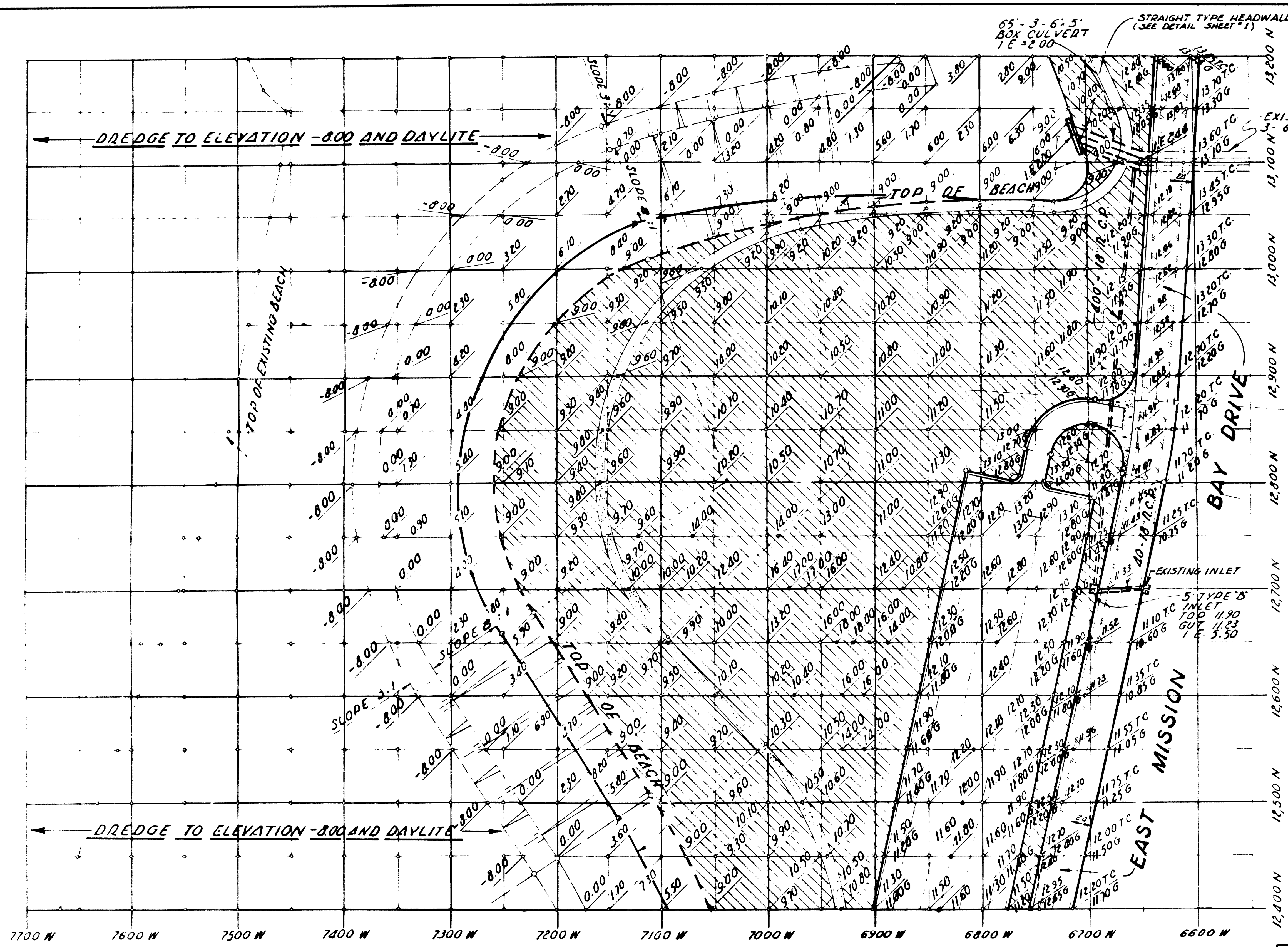

BASIS OF BEARINGS:
MISSION BAY (OLD TOWN) COORDINATE SYSTEM

BENCHMARK:
IN TOP OF INLET ON EASTERLY SIDE OF EAST MISSION BAY ± N 12,700 (NEAR MILTON STREET EXTENDED).
ELEV. = 11.137 M.L.L.W.

NOTE:
ALL ELEVATIONS SHOWN ARE FINISHED GRADE
HATCHED AREAS ARE TO RECEIVE 4" OF TOP SOIL TOP SOIL IS NOT INCLUDED WITH THIS CONTRACT.
LIMIT OF OVERDREDGING IS -8.00

DREDGING - GRADING AND DRAINAGE

CITY OF SAN DIEGO, CALIFORNIA ENGINEERING DEPARTMENT SHEET 9 OF 14 SHEETS		NO. 64,937
DESCRIPTION	APPROVED DATE	DESIGNER
ORIGINAL	D.H.M.	COUNCIL CERTIFICATION
AS BUILT	4-4-69	DATE
DRAWN BY: R. WATSON		13078-9-D

AS BUILT

Appendix B. Preliminary Drawings



CUDAHY CREEK (LEISURE LAGOON) WETLAND RESTORATION

CONTRACTOR'S RESPONSIBILITIES

- PURSUANT TO SECTION 4216 OF THE CALIFORNIA GOVERNMENT CODE, AT LEAST 2 WORKING DAYS PRIOR TO EXCAVATION, YOU MUST CONTACT THE REGIONAL NOTIFICATION CENTER (E.G., UNDERGROUND SERVICE ALERT OF SOUTHERN CALIFORNIA) AND OBTAIN AN INQUIRY IDENTIFICATION NUMBER.
- NOTIFY SDG&E AT LEAST 10 WORKING DAYS PRIOR TO EXCAVATING WITHIN 10' OF SDG&E UNDERGROUND HIGH VOLTAGE TRANSMISSION POWER LINES (I.E., 69 KV & HIGHER).

CONSTRUCTION STORM WATER PROTECTION NOTES

- TOTAL SITE DISTURBANCE AREA (ACRES) - _____
HYDROLOGIC UNIT/ WATERSHED - _____
HYDROLOGIC SUBAREA NAME & NO. - _____
- THE CONTRACTOR SHALL COMPLY WITH THE REQUIREMENTS OF THE
 - WPCP
THE PROJECT IS SUBJECT TO MUNICIPAL STORM WATER PERMIT NO. R9-2013-0001 AS AMENDED BY R9-2015-0001 AND R9-2015-0100
 - SWPPP
THE PROJECT IS SUBJECT TO MUNICIPAL STORM WATER PERMIT NO. R9-2013-0001 AS AMENDED BY R9-2015-0001 AND R9-2015-0100 AND CONSTRUCTION GENERAL PERMIT ORDER 2009-0009-DWQ AS AMENDED BY ORDER 2010-0014-DWQ AND 2012-0006-DWQ
TRADITIONAL: RISK LEVEL 1 2 3
LUP: RISK TYPE 1 2 3
- CONSTRUCTION SITE PRIORITY
 ASBS HIGH MEDIUM LOW

MONUMENTATION / SURVEY NOTES

THE CONTRACTOR SHALL BE RESPONSIBLE FOR SURVEY MONUMENTS AND/OR VERTICAL CONTROL BENCHMARKS WHICH ARE DISTURBED OR DESTROYED BY CONSTRUCTION. A LICENSED LAND SURVEYOR OR LICENSED CIVIL ENGINEER AUTHORIZED TO PRACTICE LAND SURVEYING IN THE STATE OF CALIFORNIA SHALL FIELD LOCATE, REFERENCE, AND/OR PRESERVE ALL HISTORICAL OR CONTROLLING MONUMENTS PRIOR TO ANY EARTHWORK, DEMOLITION, OR SURFACE IMPROVEMENTS. IF DESTROYED, A LICENSED LAND SURVEYOR SHALL REPLACE SUCH MONUMENT(S) WITH APPROPRIATE MONUMENT(S). WHEN SETTING SURVEY MONUMENTS USED FOR RE-ESTABLISHMENT OF THE DISTURBED CONTROLLING SURVEY MONUMENTS AS REQUIRED BY SECTIONS 6730.2 AND 8771 OF THE BUSINESS AND PROFESSIONS CODE OF THE STATE OF CALIFORNIA, A CORNER RECORD OR RECORD OF SURVEY, AS APPROPRIATE, SHALL BE FILED WITH THE COUNTY SURVEYOR. IF ANY VERTICAL CONTROL IS TO BE DISTURBED OR DESTROYED, THE CITY OF SAN DIEGO FIELD SURVEY SECTION SHALL BE NOTIFIED IN WRITING AT LEAST 7 DAYS PRIOR TO CONSTRUCTION. THE CONTRACTOR SHALL BE RESPONSIBLE FOR THE COST OF REPLACING ANY VERTICAL CONTROL BENCHMARKS DESTROYED BY THE CONSTRUCTION.

SHEET INDEX

SHEET NO.	DISCIPLINE CODE	TITLE	LIMITS
1	G-1	COVER SHEET	
2	C-1	GRADING PLAN	

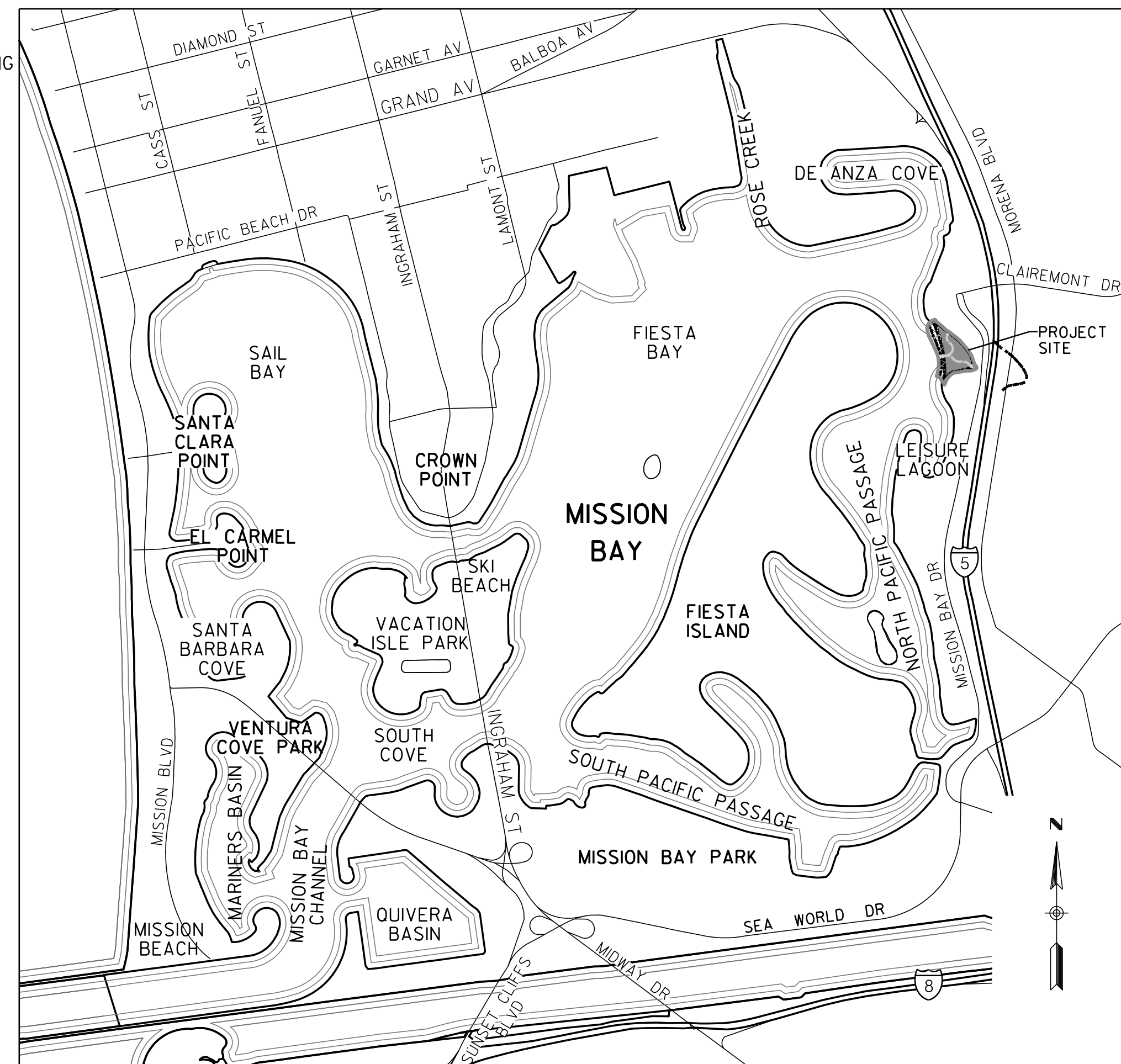

KEY MAP
NOT TO SCALE

WORK TO BE PERFORMED

THE IMPROVEMENTS CONSIST OF WETLAND CREATION AND STORM DRAIN OUTFALL IMPROVEMENTS, INCLUDING SDD-104 RIP RAP.

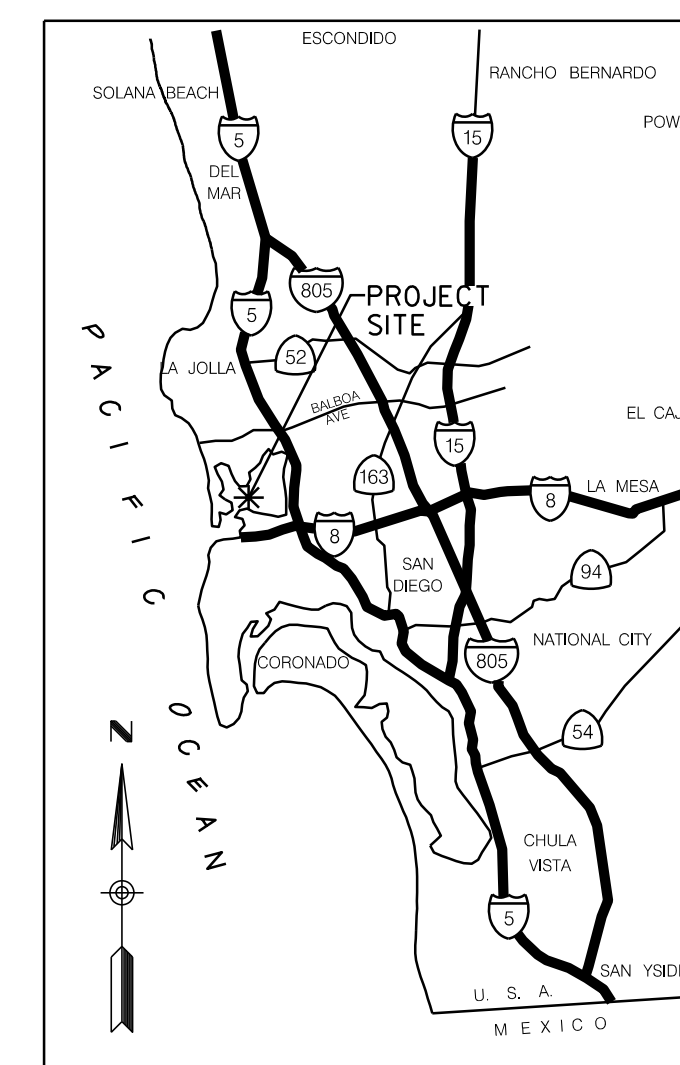

VICINITY MAP
NOT TO SCALE

FIELD DATA

BENCHMARK: BRASS PLUG AT THE SE CURB RETURN AT CROWN POINT DR AND INGRAHAM ST
ELEV. = 34.518, NGVD29

FIELD NOTES: N/A

BASIS OF BEARINGS / COORDINATES:
GPS 157 TO 154: N23° 40' 56"W, HD 10,592.61 FT
CCS 83 ZONE 6, NAD83 (EPOCH 1991.35)

DATUM: MEAN SEA LEVEL, (NVGD29)

REFERENCES: R05 14492

LEGEND

IMPROVEMENTS	STANDARD DRAWINGS	SYMBOL
MAJOR CONTOUR		— 10 —
MINOR CONTOUR		- - - - 4 - - - -
DAYLIGHT		- # - - - # -
SUBTIDAL CHANNEL		[Symbol]
LOW SALT MARSH		[Symbol]
MID SALT MARSH		[Symbol]
BERM AREA		[Symbol]
OYSTER BAG STABILIZATION		- X -
RIP RAP	SDD-104	[Symbol]
EXISTING STRUCTURES		
EX STORM DRAIN		- - - - -
EX MAJOR CONTOUR		- - - - - 10 - - - - -
EX MINOR CONTOUR		- - - - - 4 - - - - -

DISCIPLINE CODE	ABBREVIATIONS
G GENERAL	CY CUBIC YARD
C CIVIL	EL, ELEV ELEVATION
	EX, EXIST EXISTING
	FG FINISH GRADE
	FT FEET
	RCB REINFORCED CONCRETE BOX
	RCP REINFORCED CONCRETE PIPE
	SD STORM DRAIN
	TYP TYPICAL
	IE INVERT ELEVATION
	MIN MINIMUM
	PROP PROPOSED
	MIN MINIMUM

CONSTRUCTION CHANGE / ADDENDUM			
CHANGE	DATE	AFFECTED OR ADDED SHEET NUMBERS	APPROVAL NO.

WARNING
0 1
IF THIS BAR DOES NOT MEASURE 1" THEN DRAWING IS NOT TO SCALE.

The City of
SAN DIEGO Public Works

RICK ENGINEERING COMPANY
5620 FRIARS ROAD
SAN DIEGO, CA 92110
619-291-0707
(FAX) 619-291-4165
rickengineering.com
San Diego Riverside - Orange - Sacramento - San Luis Obispo - Phoenix - Tucson - Denver

SPEC. NO.		CITY OF SAN DIEGO, CALIFORNIA PUBLIC WORKS DEPARTMENT SHEET 1 OF 2 SHEETS		WBS	
APPROVED:		FOR CITY ENGINEER		DATE	
PRINT NAME		RCE#		PROJECT MANAGER	
DESCRIPTION	BY	APPROVED	DATE	FILMED	PROJECT ENGINEER
ORIGINAL	REC				226-1701 CCS27 COORDINATE
					1866-6261 CCS83 COORDINATE
CONTRACTOR	INSPECTOR	DATE STARTED	DATE COMPLETED	XXXXX-01-D	

PRELIMINARY
NOT FOR CONSTRUCTION

CUDAHY CREEK

G-1

EAST MISSION DRIVE
BAY DRIVE

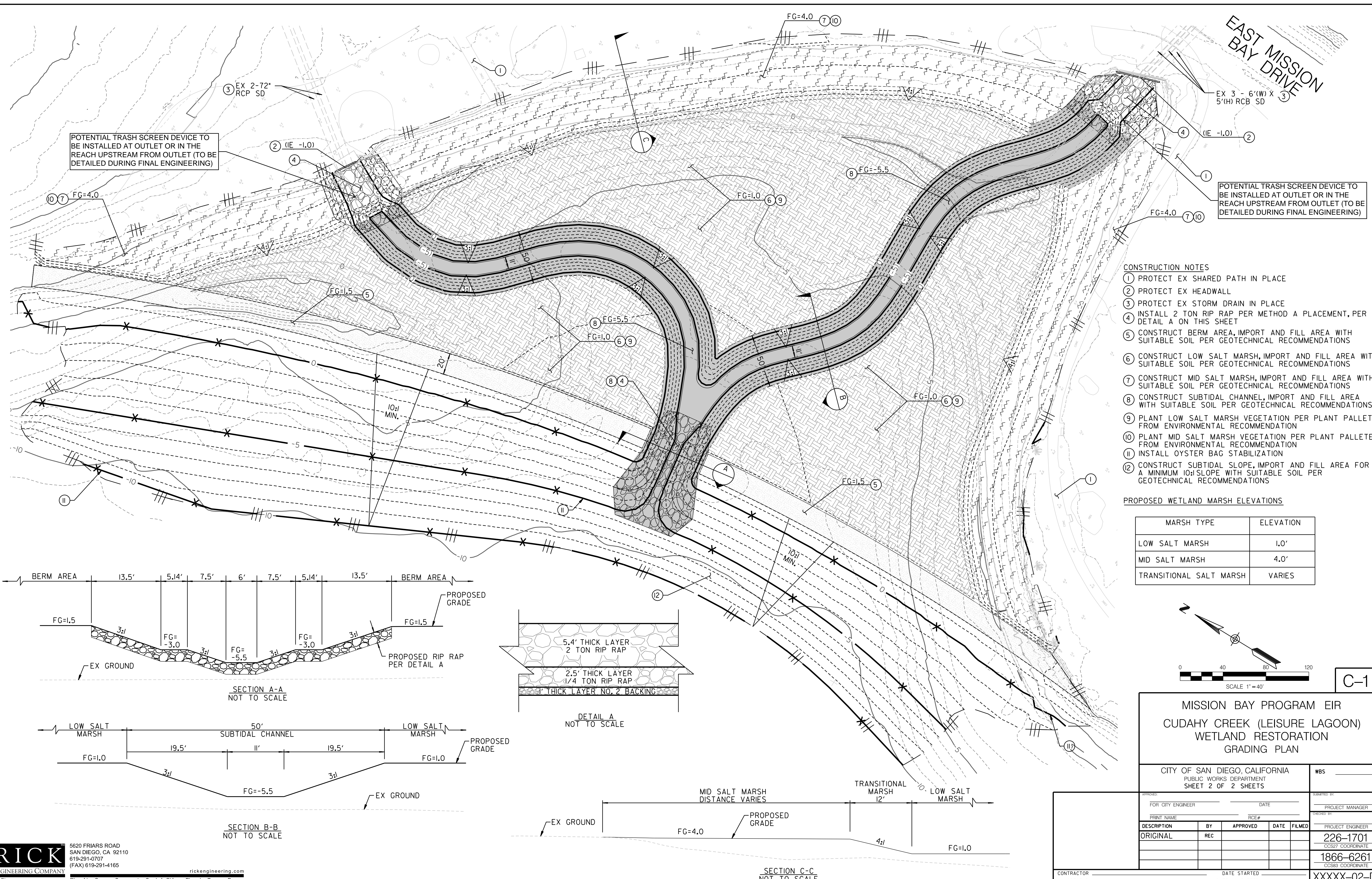

POTENTIAL TRASH SCREEN DEVICE TO BE INSTALLED AT OUTLET OR IN THE REACH UPSTREAM FROM OUTLET (TO BE DETAILED DURING FINAL ENGINEERING)

POTENTIAL TRASH SCREEN DEVICE TO BE INSTALLED AT OUTLET OR IN THE REACH UPSTREAM FROM OUTLET (TO BE DETAILED DURING FINAL ENGINEERING)

- CONSTRUCTION NOTES**
- 1 PROTECT EX SHARED PATH IN PLACE
 - 2 PROTECT EX HEADWALL
 - 3 PROTECT EX STORM DRAIN IN PLACE
 - 4 INSTALL 2 TON RIP RAP PER METHOD A PLACEMENT, PER DETAIL A ON THIS SHEET
 - 5 CONSTRUCT BERM AREA, IMPORT AND FILL AREA WITH SUITABLE SOIL PER GEOTECHNICAL RECOMMENDATIONS
 - 6 CONSTRUCT LOW SALT MARSH, IMPORT AND FILL AREA WITH SUITABLE SOIL PER GEOTECHNICAL RECOMMENDATIONS
 - 7 CONSTRUCT MID SALT MARSH, IMPORT AND FILL AREA WITH SUITABLE SOIL PER GEOTECHNICAL RECOMMENDATIONS
 - 8 CONSTRUCT SUBTIDAL CHANNEL, IMPORT AND FILL AREA WITH SUITABLE SOIL PER GEOTECHNICAL RECOMMENDATIONS
 - 9 PLANT LOW SALT MARSH VEGETATION PER PLANT PALLETE FROM ENVIRONMENTAL RECOMMENDATION
 - 10 PLANT MID SALT MARSH VEGETATION PER PLANT PALLETE FROM ENVIRONMENTAL RECOMMENDATION
 - 11 INSTALL OYSTER BAG STABILIZATION
 - 12 CONSTRUCT SUBTIDAL SLOPE, IMPORT AND FILL AREA FOR A MINIMUM 10:1 SLOPE WITH SUITABLE SOIL PER GEOTECHNICAL RECOMMENDATIONS

PROPOSED WETLAND MARSH ELEVATIONS

MARSH TYPE	ELEVATION
LOW SALT MARSH	1.0'
MID SALT MARSH	4.0'
TRANSITIONAL SALT MARSH	VARIES

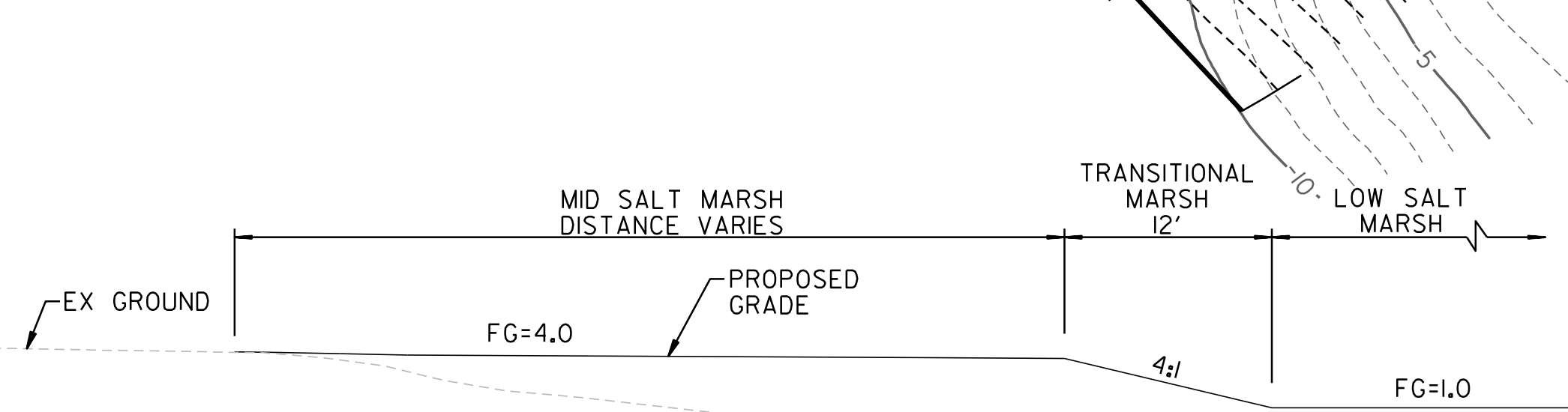
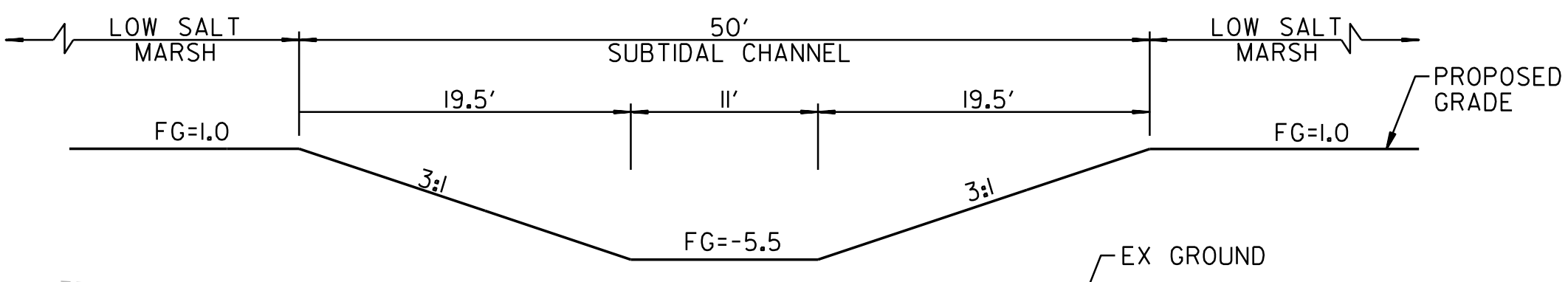
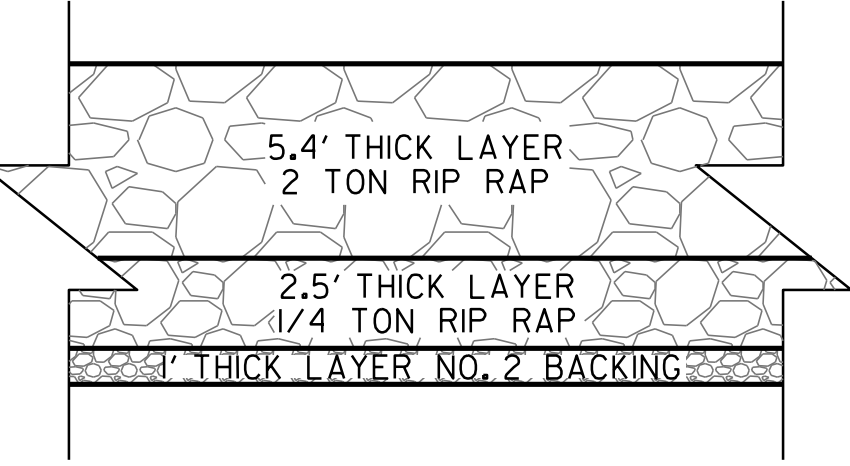
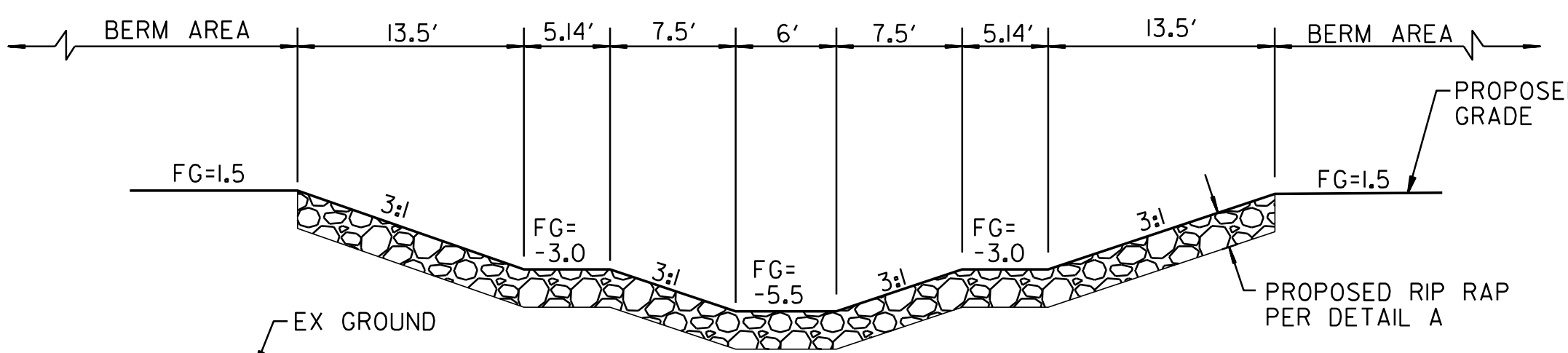
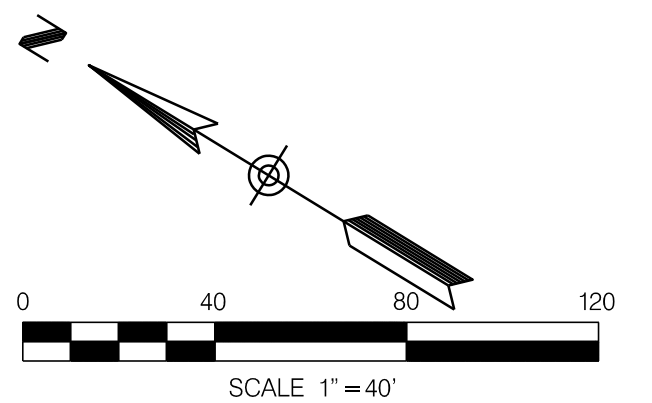

C-1

MISSION BAY PROGRAM EIR
CUDAHY CREEK (LEISURE LAGOON)
WETLAND RESTORATION
GRADING PLAN

CITY OF SAN DIEGO, CALIFORNIA
PUBLIC WORKS DEPARTMENT
SHEET 2 OF 2 SHEETS

APPROVED:	DATE:	PROJECT MANAGER:			
FOR CITY ENGINEER:	DATE:	PROJECT MANAGER:			
PRINT NAME:	RCE#:	CHECKED BY:			
DESCRIPTION	BY	APPROVED	DATE	FILED	PROJECT ENGINEER
ORIGINAL	REC				226-1701
					CCS27 COORDINATE
					1866-6261
					CCS83 COORDINATE
CONTRACTOR	DATE STARTED	INSPECTOR	DATE COMPLETED	XXXXX-02-D	

RICK ENGINEERING COMPANY
5620 FRIARS ROAD
SAN DIEGO, CA 92110
619-291-0707
(FAX) 619-291-4185
rickengineering.com
San Diego Riverside - Orange - Sacramento - San Luis Obispo - Phoenix - Tucson - Denver

C:\RICK\Projects\C_SD_T\18097_MissionBayPEIR\Civil\Leisure Lagoon\Sheets\18097AC_C-1_Leisure Lagoon.dgn

PRELIMINARY
NOT FOR CONSTRUCTION

CUDAHY CREEK

Appendix C. Opinion of Probable Costs



Mission Bay Park
Cudahy Creek Salt Marsh Restoration PER

PREPARED BY: KDM
CHECKED BY: AT

JOB NO.: 18097-A
DATE: 6/27/2024
REVISED

ITEM	DESCRIPTION (CONSTRUCTION ITEMS)	UNIT	QUANTITY		UNIT PRICE	TOTAL COST
				TOTAL		
1	RIPRAP, PER SDD-104 (2.0 TON)	CY	2,900		\$340.00	\$986,000
2	IMPORT	CY	58,000		\$30.00	\$1,740,000
3	LOW SALT MARSH (LOW CHORD)	SF	150,700		\$2.80	\$421,960
4	MID SALT MARSH (MID CHORD)	SF	68,700		\$2.80	\$192,360
5	OYSTER BAG BANK STABILIZATION	SF	127,900		\$5.50	\$703,450
6	PERIMETER FENCE (6-FOOT CHAIN LINK)	LF	1,800		\$28.00	\$50,400
CONSTRUCTION SUBTOTAL						\$4,094,170
30% CONTINGENCY						\$1,228,251
TOTAL CONSTRUCTION COSTS						\$5,322,400
PLANNING AND DESIGN (40% OF CONSTRUCTION)						\$2,129,000
ENVIRONMENTAL PERMITTING (5% OF CONSTRUCTION)						\$266,100

ITEM	DESCRIPTION (MAINTENANCE PERIOD ITEMS)	UNIT	QUANTITY		UNIT PRICE	TOTAL COST
				TOTAL		
1	120-Day Plant Establishment Period (PEP) (25% re-planting Marsh)	SF	54,850		\$2.80	\$153,580
2	5-Year Maintenance (10% re-planting slope Year 1)	SF	21,940		\$2.80	\$61,432
3	5-Year Maintenance (10% re-planting slope Year 2)	SF	21,940		\$2.80	\$61,432
4	5-Year Maintenance (10% re-planting slope Year 3)	SF	21,940		\$2.80	\$61,432
5	5-Year Maintenance (5% re-planting slope Year 4)	SF	10,970		\$2.80	\$30,716
6	5-Year Maintenance (Quarterly Inspections- 12 hours per inspection)	HR	240		\$210.00	\$50,400
7	5-Year Annual Reporting (40 hours per report)	HR	200		\$210.00	\$42,000
MAINTENANCE SUBTOTAL						\$460,992
30% CONTINGENCY						\$138,298
TOTAL MAINTENANCE COSTS						\$599,300
TOTAL						\$8,316,800

1. UNIT COSTS DERIVED FROM THE CITY OF SAN DIEGO UNIT PRICE LIST AND SIMILAR PROJECT COST ESTIMATES.
2. COSTS DO NOT INCLUDE ANNUAL MAINTENANCE, RIGHT OF WAY ACQUISITION, OR EASEMENT DOCUMENT PREPARATION OR RECORDATION.
3. SUBTOTAL COST ROUNDED UP TO NEAREST \$1,000.
4. MOBILIZATION AT 6% OF TOTAL COST

Appendix D. Preliminary Project Schedule

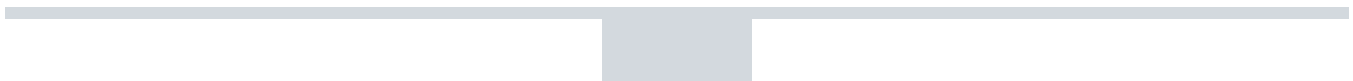

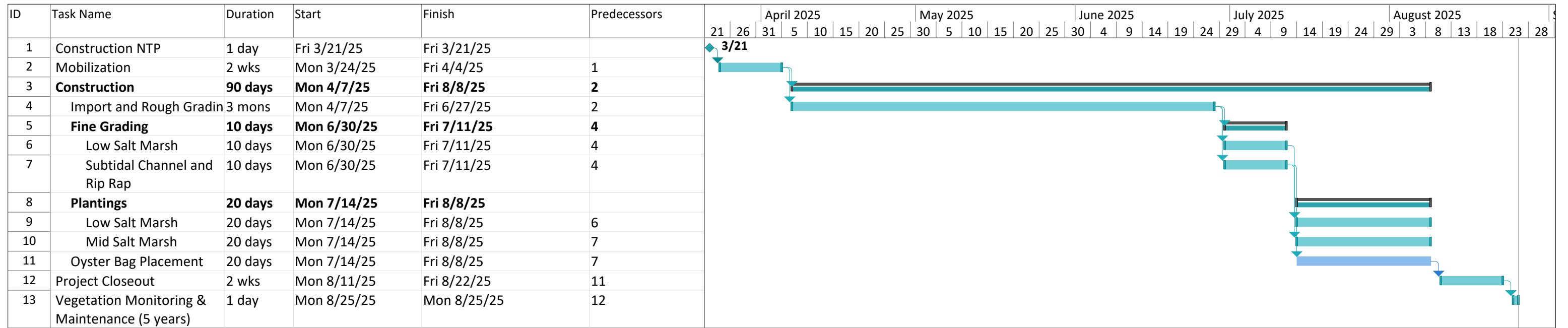

Project: Cudahy Creek Salt Marsh Date: Thu 6/27/24	Task		Project Summary		Inactive Milestone		Manual Summary Rollup		Deadline	
	Split		External Tasks		Inactive Summary		Manual Summary		Progress	
	Milestone		External Milestone		Manual Task		Start-only		Manual Progress	
	Summary		Inactive Task		Duration-only		Finish-only			

Appendix E. Risk Assessment Table

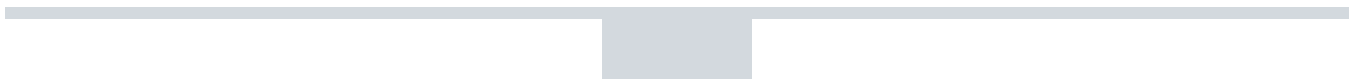

RISK ASSESSMENT TABLE			Project Name: Cudahy Creek Wetland Restoration	J-18097-A				
				Risk Assessment			Risk Response	
ID #	Category	Title	Risk Statement	Probability	Cost Impact	Time Impact	Strategy	Response Actions
1	PM	Land Ownership	As a result of this project being in a public park owned and maintained by the City of San Diego, there are no land ownership conflicts that may present risk to the project.	Very Low	Low	Moderate	None	None
2	PM	Utilities	There are no known utility conflicts, and the project grading primarily consists of placing fill materials. For the minor shoreline cleanup that will require shallow excavation, encountering unforeseen utilities could cause schedule delays and increased costs.	Very Low	Moderate	High	Mitigate	The contractor shall notify Underground Service Alert (USA) so that utilities are accurately marked in the field prior to initiating maintenance activities that requires minor digging. The contract shall also hire a private utility locator for areas where USA will not provide clearance for.
3	Construction	Existing Soil Data	Soil data has not been explored at this time. Further geotechnical investigations may be required to design the pavement and water quality features. If compromised or contaminated soils are discovered on the site, mitigation will be required which will delay the schedule, and increase costs.	Very Low	Moderate	Moderate	Mitigate	Project grading will primarily consist of placing fill materials. The fill materials shall be verified to be not be contaminated prior to being sourced for this project. The risk of associated with source materials being contaminated is associated with whatever project those materials are being generated at. Testing to confirm materials are appropriate shall be performed in order to reduce the risk to this project.
4	Construction	Proximity to Neighbors	Some of the replacement/repair work may have noise and traffic impacts on visitors, residents, and commercial businesses.	Moderate	Low	Low	Mitigate	The contractor will be required to use construction methods or time windows that reduce the noise and vibration impacts to the surrounding park and bay areas, such as work being scheduled outside of peak season (May to September).

RISK ASSESSMENT TABLE			Project Name: Cudahy Creek Wetland Restoration				J-18097-A	
			Risk Assessment			Risk Response		
ID #	Category	Title	Risk Statement	Probability	Cost Impact	Time Impact	Strategy	Response Actions
5	Environmental	Environmental Windows	Environmental constraints of endangered bird nesting seasons require that construction activities be limited near the bird nesting sites during nesting season.	Low	Low	Low	Mitigate	Construction timing and proximity to bird nesting sites will need to be considered in the planning phase of replacement and/or repair activities. The closest know sensitive bird population is the California Least terns on Fiesta Island, which is located more than 500 feet from the project boundary.
6	Environmental	Water Quality Concerns	The project grading adjacent to and part of the Mission Bay has the potential to impact the water quality of the bay.	Moderate	Moderate	Moderate	Mitigate	Grading activities will be required to adhere to construction storm water BMP requirements with special provisions to be implemented to be protective of the bay, including but not limited to installing and maintaining a silt curtain between the project and the open waters of the bays, construction sequencing (i.e., building berm first to act as a barrier), limiting the rate that is fill is placed on the berm, and conducting daily monitoring of TSS in the bay during construction activities.
7	PM	Competing Interests	There is a potential that the public may perceive the project as reducing the area available for recreation actives.	Very Low	Low	Low	None	Currently, the project area is comprised of mudflat and shallow open water area that does not support recreational actives, such as swimming, fishing, rowing, or motor boating. Being that the project area is not currently being used for recreation by the public, the risk identify is none.

RISK ASSESSMENT TABLE			Project Name: Cudahy Creek Wetland Restoration				J-18097-A	
			Risk Assessment			Risk Response		
ID #	Category	Title	Risk Statement	Probability	Cost Impact	Time Impact	Strategy	Response Actions
8	Environmental	Sensitive Habitat	Project grading has the potential to impact sensitive habitat.	Low	Moderate	Moderate	Mitigate	The project proposes to place fill materials in areas currently identified as either open water or low-quality mudflat to create primarily low salt marsh wetland habitat with some transitional salt marsh wetland habitat as well as subtidal channels and mudflat area. Based on this, the project is anticipated to be beneficial related to sensitive habitat.
9	Environmental	Sea Level Rise	In the future, sea level rise (SLR) may impact the proposed project features.	Moderate	Moderate	Low	Mitigate	Based on the <i>Rewild Mission Bay Wetland Feasibility Study</i> (Everest, 2018), low salt marsh in the bay occurs in the elevation range of 0.3 to 2.3 ft (NGVD29). The project proposes low salt marsh at elevations between 0.9 and 1.1 ft (NGVD29). This will allow for SLR resilience of approximately 0.6 to 0.8 ft. Storm events may result in the deposition of sediment to keep up with or at least offset (i.e., delay) impacts from SLR. Additionally, thin layer of sediment placement may be implemented in the future to raise the low salt marsh area consistent with the observed pace of SLR. SLR raise and the low salt marsh area elevation shall be monitored in the future to better assess the impact of SLR and guidance discussion making.

RISK ASSESSMENT TABLE			Project Name: Cudahy Creek Wetland Restoration				J-18097-A	
			Risk Assessment			Risk Response		
ID #	Category	Title	Risk Statement	Probability	Cost Impact	Time Impact	Strategy	Response Actions
10	PM	Permitting	The regulatory process to permit the project may result in additional project cost and time delays.	Moderate	Moderate	High	None	As a result of changing regulations and standards, the introduction of new guidelines may occur, which would lead to additional permitting costs. In order to mitigate for unanticipated regulatory permitting challenges, the project planning team shall coordinate meetings with resource agencies to maximum extent practical, including a pre-application meeting, application meeting, and other meetings as needed.

Appendix F. Project Goals and Objectives Table



PROJECT GOALS AND POTENTIAL BENEFITS TABLE		Project Name:	Cudahy Creek Wetland Restoration					J-18097-A
		Overall Project Goals (Qualitative Outcome)						
ID #	Potential Benefits	Description/ Qualitative Outcome	Water Quality Improvements	Aquatic Resources	Fish and Wildlife Species	Environmental Enhancement	Recreation	Quantitative Outcome
1	Habitat creation	<ul style="list-style-type: none"> •Improve wetland habitat. •The wetland will draw birds to area and create an opportunity for bird watching. •Interface between the wetland and the open water has been designed to correlate with the curvature of the passage channel, which will allow for aquatic recreation to continue. •Improved water quality will promote distributed aquatic recreation opportunities throughout Mission Bay, however the change from beach shoreline to wetland area may reduce aquatic recreation within the project boundary. Currently, the project area is comprised of mudflat and shallow open water area that does not support recreational activities, such as swimming, fishing, rowing, or motor boating. •The creation sensitive habitat will expand recreational opportunities to include bird watching, attracting new visitors to the immediate area and help offset the potential reduction in aquatic recreation opportunities within the project boundary. 	X	X	X	X	X	•Creation of 5.2 acres of salt marsh habitat.
2	Storm water runoff water quality improvement	<ul style="list-style-type: none"> •Storm water runoff will inundate the low salt marsh area and be treated through biological uptake before entering the deeper waters of Mission Bay. •Removal of pollutants from stormwater runoff through the restored wetland habitat will improve the overall quality of water in Mission Bay, improving public safety and recreational use while providing benefits for wildlife. 	X	X	X	X	X	•Wetland received storm water runoff from 864 acres of urban development consisting primarily of single-family residential with commercial, industrial, and transportation land use types.
3	Flood control	<ul style="list-style-type: none"> •The channel will be designed to adequately convey runoff. 				X		•The channel has been designed to convey the 100-year storm event.
4	Reduced maintenance	<ul style="list-style-type: none"> •Subtidal channels have been designed so that during wet weather events, flow velocities are such that sediment deposition will be minimal. •A trash capture device may be proposed to reduce trash removal from Mission Bay. •Trash Capture device maintenance frequency is site specific. During the first year of operation an inspection should be made prior to the rainy season in August and then monthly through May. Observations from these inspections performed by the City will inform long-term maintenance practices and frequency. 		X	X	X		<ul style="list-style-type: none"> •Based on the rough-order-magnitude TSS removal estimate, it would take approximately 30 years to cover 3.5 acres to a depth of 3 inches with sediment (see Section 5.1.5). SLR is expected to out pace sediment accumulation. • Maintenance will be at least bi-annual, occurring once before and once after the rainy season.
5	Resilience linked to future climate change and sea level rise	<ul style="list-style-type: none"> •Salt marsh restoration at Cudahy Creek has been designed at elevations at the mid-range of elevation range as means to provide resilience to Sea Level Rise (SLR). •Monitoring of the observed SLR in comparison with the wetland elevation shall be performed, and the implementation of the adaptation management strategy of thin layer sediment placement may be implemented, as needed, in the future. 		X	X	X		<ul style="list-style-type: none"> •Monitoring of the observed SLR in comparison with the wetland elevation and implement the adaptation management strategy of thin layer sediment placement may be implemented if needed in the future. Based on current prediction data, it is estimated that the SLR has a 50% probability to begin to affect wetland vegetation in 2040. •Estimated SLR resilience of 0.6-0.8 ft is built into the design by establishing a low salt marsh elevation of 0.9-1.1 ft (NGVD29). •Extended SLR Resilience may be achieved by applying a thin layer of sediment to the entirety of the project area to raise marsh plains and preserve the habitat created. •Sediment addition will be as-needed based on long-term SLR conditions (2050-2100+).