

**APPENDIX H**  
*Seawall PER*



# Preliminary Engineering Report

## Mission Bay Park Improvement PEIR

# Mission Beach Seawall Improvements

# Feasibility Study

November 2022, Revised May 2024

### ***Presented To***

**City of San Diego Public Works Department**  
525 B Street, Suite 750, MS 908A  
San Diego, CA 92101



### ***Presented By***

**Moffatt & Nichol**  
1660 Hotel Circle N, Suite 500  
San Diego, CA 92108

P +1-619-220-6050  
F +1-619-220-6055  
moffattnichol.com



Prepared by:

A handwritten signature in blue ink, appearing to read "Alex Ford".

---

Alexandra Ford, P.E.  
Project Engineer

May  
2024

Reviewed by:

A handwritten signature in blue ink, appearing to read "Craig Frampton".

---

Craig Frampton  
Coastal Scientist

May  
2024

Authorized by:

A handwritten signature in blue ink, appearing to read "Christopher Webb".

---

Christopher Webb  
Supervisory Coastal Scientist

May 2024

## Contents

<b>1.0 INTRODUCTION</b> .....	<b>1</b>
1.1 Project Setting .....	2
1.2 Project Location .....	4
1.3 Project Goals and Objectives .....	6
<b>2.0 DATA COLLECTION AND EXISTING CHARACTERISTICS</b> .....	<b>7</b>
2.1 Topography/Bathymetry .....	7
2.2 Available GIS Data.....	7
2.3 As-builts.....	7
2.4 Project Datum and Units .....	8
<b>3.0 EXISTING CONDITIONS</b> .....	<b>9</b>
3.1 Mission Beach Seawall .....	9
3.2 Architectural Features for Historical Preservation.....	12
3.3 Oceanographic Conditions .....	12
3.3.1 Astronomical Tides .....	12
3.3.2 Sea Level Rise .....	13
3.3.3 FEMA Flood Maps .....	16
<b>4.0 PRELIMINARY DESIGN</b> .....	<b>17</b>
4.1 Project Components.....	17
4.1.1 Current Conditions .....	17
4.1.2 Concept Design Options .....	18
4.2 Preliminary Opinion of Probable Construction Cost .....	34
4.3 Preliminary Project Schedule .....	35
<b>5.0 OTHER CONSIDERATIONS AS APPROPRIATE</b> .....	<b>36</b>
5.1 Feasibility Analysis of Constructability.....	36
5.1.1 Desired Construction Condition .....	36
5.1.2 Construction Process .....	36
5.2 Risk Assessment.....	39
5.2.1 Land Ownership.....	39
5.2.2 Utilities.....	39
5.2.3 Existing Geology Data.....	40
5.2.4 Proximity to Neighbors .....	42
5.2.5 Environmental Windows.....	42
5.2.6 Water Quality Concerns .....	43
5.2.7 Competing Interests .....	44
5.2.8 Sensitive Habitat .....	44
5.2.9 Sea Level Rise .....	44
5.3 Project Conflict Coordination and Evaluation.....	50

5.3.1	Mission Bay Park Improvement Program Projects .....	50
5.3.2	Capital Improvement Plan Projects.....	50
5.4	Environmental Considerations and Permits .....	51
5.4.1	Noise Control.....	53
5.5	City Professional Standards and Mission Bay Masterplan Consistency.....	54
5.6	ADA and Title 24.....	56
5.6.1	Americans with Disabilities Act 1990 .....	56
5.6.2	Title 24.....	57
<b>6.0</b>	<b>BIBLIOGRAPHY .....</b>	<b>58</b>

## Appendices

**A. FEMA PRELIMINARY FLOOD MAPS**

**B. PRELIMINARY DRAWINGS**

**C. PRELIMINARY OPINION OF PROBABLE CONSTRUCTION COST ESTIMATE**

**D. RISK ASSESSMENT TABLE**

## Tables

Table 2-1.	SanGIS Data Inventory .....	7
Table 2-2.	Summary of City of San Diego As-Built Drawings Reviewed.....	8
Table 3-1.	Existing Still Water Levels at Mission Beach (NOAA Station 9410230) .....	13
Table 3-2.	Sea Level Rise Projections – San Diego, CA .....	15
Table 4-1.	ROM Cost Estimate Summary .....	34
Table 4-2.	Durations for Each Project Component.....	35
Table 5-1.	Sea Level Rise Projected Still Water Levels.....	45
Table 5-2.	Wave Overtopping Analysis.....	50
Table 5-3.	Environmental Permit Considerations.....	53
Table 5-4.	Typical Construction Equipment Noise Levels.....	54
Table 5-5.	Inventory of Relevant Standards .....	55

## Figures

Figure 1-1.	Vicinity Map.....	2
Figure 1-2.	Aerial View of Mission Beach and False Bay – 1930 (www.sandiego.gov).....	4
Figure 1-3.	Project Location.....	5
Figure 1-4.	Original Seawall Construction Phasing .....	6
Figure 3-1.	1925 Seawall Section .....	10
Figure 3-2.	1928 Seawall Section .....	10
Figure 3-3.	1968 Seawall Section .....	11
Figure 3-4.	2000 Seawall Section .....	11
Figure 3-5.	Updated sea level scenarios from 2020 to 2150, in ft, relative to a baseline value of year 2000 recorded sea levels.....	14
Figure 3-6.	Sea Level Rise Projections – San Diego, CA .....	15
Figure 4-1.	Segment A - Option 1 - Parapet Modified Replacement-in-Kind .....	21
Figure 4-2.	Segment A - Typical Void Repair Under Walkway.....	23
Figure 4-3.	Segment A - Option 2 – Raised Boardwalk .....	25
Figure 4-4.	Segment B - Parapet Replacement-in-Kind .....	26
Figure 4-5.	Segment C - Option 1 – Seawall .....	28
Figure 4-6.	Segment C - Option 2 – “Decorative” Wall .....	29
Figure 4-7.	Existing Pedestrian Beach Access Locations within Project Limits .....	29
Figure 4-8.	Existing Stair Example (1999 plans).....	30
Figure 4-9.	Beach Access Stairs.....	31
Figure 4-10.	Beach Access ADA Ramp.....	32
Figure 4-11.	Beach Access Driveway - Plan .....	33
Figure 4-12.	Beach Access Driveway - Section .....	33
Figure 5-1.	Mission Beach Seawall Utilities .....	40
Figure 5-2.	Tidal Inundation Limits Along the Mission Bay Seawall Improvement Sections.....	46
Figure 5-3.	Tidal Inundation Levels at Mission Beach .....	47
Figure 5-4.	Storm Flood Limits Along the Mission Bay Seawall Improvement Sections .....	48

Figure 5-5. Flood Inundation Limits at Mission Beach ..... 49  
 Figure 5-6. Adjacent CIP Projects..... 51

## Acronyms/Abbreviations

Acronym/Abbreviation	Definition
ADA	American with Disabilities Act
Ave	Avenue
BA	Biological Assessment
BFE	base flood elevation
bgs	below ground surface
Blvd	Boulevard
BMP	best management practice
BTR	Biological Technical Report
CCC	California Coastal Commission
CDFW	California Department of Fish and Wildlife
cfs/ft	cubic feet per second per foot
City	City of San Diego / City of San Diego Department of Public Works, Planning, and Parks and Recreation
CoSMoS	Coastal Storm Modelling System
CWA	Clean Water Act
Dr	Drive
FEMA	Federal Emergency Management Agency
FIRM	flood insurance rate maps
ESA	Endangered Species Act
ft	foot, feet
GIS	Geographic Information System
HOT	Highest Observed Tide
LOT	Lowest Observed Tide
M&N	Moffatt & Nichol
MHW	Mean High Water
MLLW	Mean Lower-Low Water
MLW	Mean Low Water
MSL	Mean Sea Level (0 Ft. elevation on NGVD 1929)
NAVD88	North American Vertical Datum of 1988
NGVD29	National Geodetic Vertical Datum of 1929
NOAA	National Oceanic and Atmospheric Administration
NPDES	National Pollution Discharge Elimination System

Acronym/Abbreviation	Definition
OPC	Ocean Protection Council
PEIR	Program Environmental Impact Report
PER	Project Engineering Report
PI	Place
RGP	Regional General Permit
ROM	Rough order of magnitude
RWQCB	California Regional Water Quality Control Board
SanGIS	San Diego Geographic Information Source
SLR	sea level rise
SSA	Special Study Area
SWL	still water level
SWPPP	storm water pollution prevention plan
USACE	U.S. Army Corps of Engineers
USFW	U.S. Fish and Wildlife Service
USGS	U.S. Geological Survey
WDRs	General Waste Discharge Requirements

## 1.0 Introduction

As a part of the Mission Bay Park Program Environmental Impact Report (PEIR), this Mission Beach Seawall Improvements Feasibility Study Project Engineering Report (PER) provides environmental, design, and construction details for the Mission Beach boardwalk and seawall within Mission Bay Park in the City of San Diego, California (Figure 1-1). The seawall location is the westernmost boundary of the Park. This PER is prepared for the City of San Diego (City) by Moffatt & Nichol (M&N) as a subconsultant to Dudek.

As part of the Mission Bay PEIR, the City of San Diego Department of Public Works, Planning, and Parks and Recreation (City) has been working with Dudek and M&N to develop a feasibility study for improvements to the aging Mission Beach Seawall. The seawall is designed to protect coastline infrastructure from damage due to environmental impacts, such as wave action and storm surges.

The improvements studied in this report are considered in three main segments along the seawall. Segment A is an 8,760-foot-long section of wall from Balboa Court to Pacific Beach Drive (excluding the wall in front of Belmont Park). Two Segment A options are studied: Option 1 would replace the existing parapet on top of the seawall and infill voids below the sidewalk, while Option 2 would raise the boardwalk and parapet to address sea level rise. Segment B is a 1,020-foot-long segment from Pacific Beach Drive to Thomas Avenue. For this segment, replacement of the existing parapet on top of the seawall is studied. Segment C is a 375-foot-long segment of wall from Thomas Avenue to Grand Avenue: for this segment two new wall options are considered: 1) a new seawall designed to be similar to the existing seawall and 2) a new “decorative” wall that is not as robust as a seawall.

In addition to the wall improvements, the study also evaluates reconstructing the 14 existing beach access stair “pop-outs” to provide either code-compliant stairways or ADA ramps. A new vehicular access location is also studied at Thomas Avenue, which would allow City equipment to access the beach.

This PER will assess the seawall’s vulnerability to SLR and establish rough order of magnitude (ROM) costs for repairs and conceptual design options. A risk assessment that analyzes the risks associated with the seawall options, including secondary impacts associated with shoreline protection, is also provided.



**Figure 1-1. Vicinity Map**

## 1.1 Project Setting

Mission Bay is located within the City of San Diego, California. This coastal inlet was created over 18,000 years ago, after the last glacial period, as sea level rose to present level, and riverine drainage incised the inlet. As sea level rose, the San Diego River deposited large volumes of alluvial sediment and created the delta that became the landmass for Mission Bay, named False Bay by early explorers (Figure 1-2). During the 1820s, the San Diego River was redirected from False Bay into San Diego Bay. This left False Bay as a low-flow marshland. False Bay was made up of fluvial and estuarine fine sands, silts, and clays from the surface to approximately 60 feet (ft) below ground surface (bgs), which were underlain by Quaternary-age dense clayey sands, hard clays, and gravel/cobble from approximately 50-70 ft bgs south of North Mission Bay Drive and approximately 10-30 ft bgs north of North Mission Bay Drive.

False Bay was historically unnavigable as the channels were narrow and shallow. The City began dredging in 1946 to create Mission Bay Park. Dredging operations, and subsequent land creation with dredged and upland material, occurred between 1946 to 1956, 1959 to 1961, and 1963 to 1964 to create the current configuration of Mission Bay. Landforms, such as De Anza, were formed with what is geologically described as Artificial Fill. This Artificial Fill consists primarily of loose to medium dense silty sands, with intermittent layers of soft clay.

Mission Bay is a popular destination for both tourists and locals of San Diego. It is located just south of the Pacific Beach community and is surrounded with land on the north, south, and east sides. On the west side of the bay is the Pacific Ocean. The bay is connected to the ocean through the Mission Bay Channel. The western side of Mission Bay consists of a narrow peninsula, which is commonly referred to as Mission Beach. This peninsula stretches approximately 2.5 miles along the coastline with public beach access throughout its length.

Running parallel to the beach is the oceanfront boardwalk. The boardwalk is home to businesses, residential units, and park space that includes Belmont Park (a historic oceanfront amusement park). To prevent coastal erosion and to protect the boardwalk and its infrastructure from damages due to environmental impacts, a seawall is used as a physical barrier between the beach and boardwalk.

The Mission Beach Boardwalk and Seawall was built over a span of several different time periods, beginning with the original construction directly in front of Belmont Park in 1925. Later, the seawall and boardwalk were expanded to the north and south until eventually they stretched along the entire peninsula. Lengthy portions of the wall north and south of Belmont Park were originally constructed in 1928 while the southernmost region near the Mission Bay Channel was constructed much later in 1968.



Figure 1-2. Aerial View of Mission Beach and False Bay – 1930 ([www.sandiego.gov](http://www.sandiego.gov))

## 1.2 Project Location

This project consists of providing concepts and costs for improvements along approximately 9,780 linear ft of the existing seawall, and creation of approximately 375 linear feet of new wall for a total project length of 10,155 linear feet. The 10,155 linear feet is broken up into two reaches along Mission Beach Boardwalk. The first reach starts at the intersection of Balboa Ct. and continues north to San Fernando Pl. The second reach of the project starts at the intersection of Ventura Pl. and continues up to Grand Ave. The overall project location is depicted in Figure 1-3. See Figure 1-4 for the time sequence of Mission Beach seawall construction.

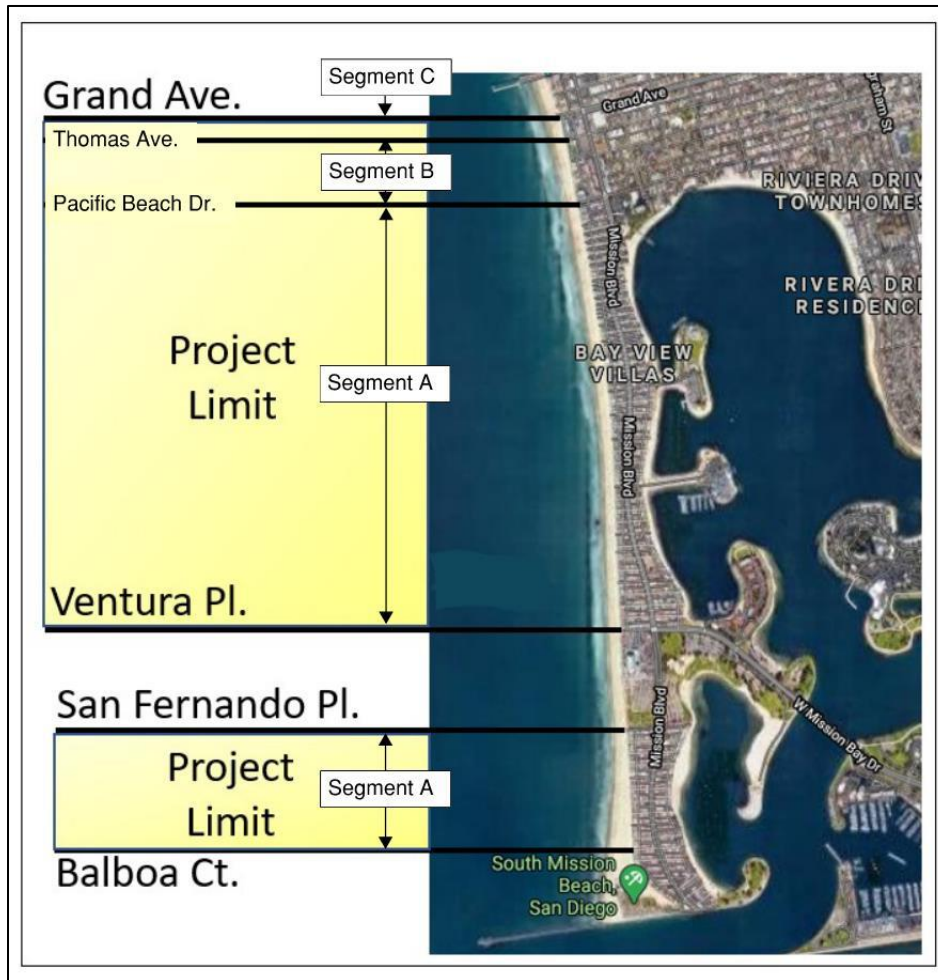
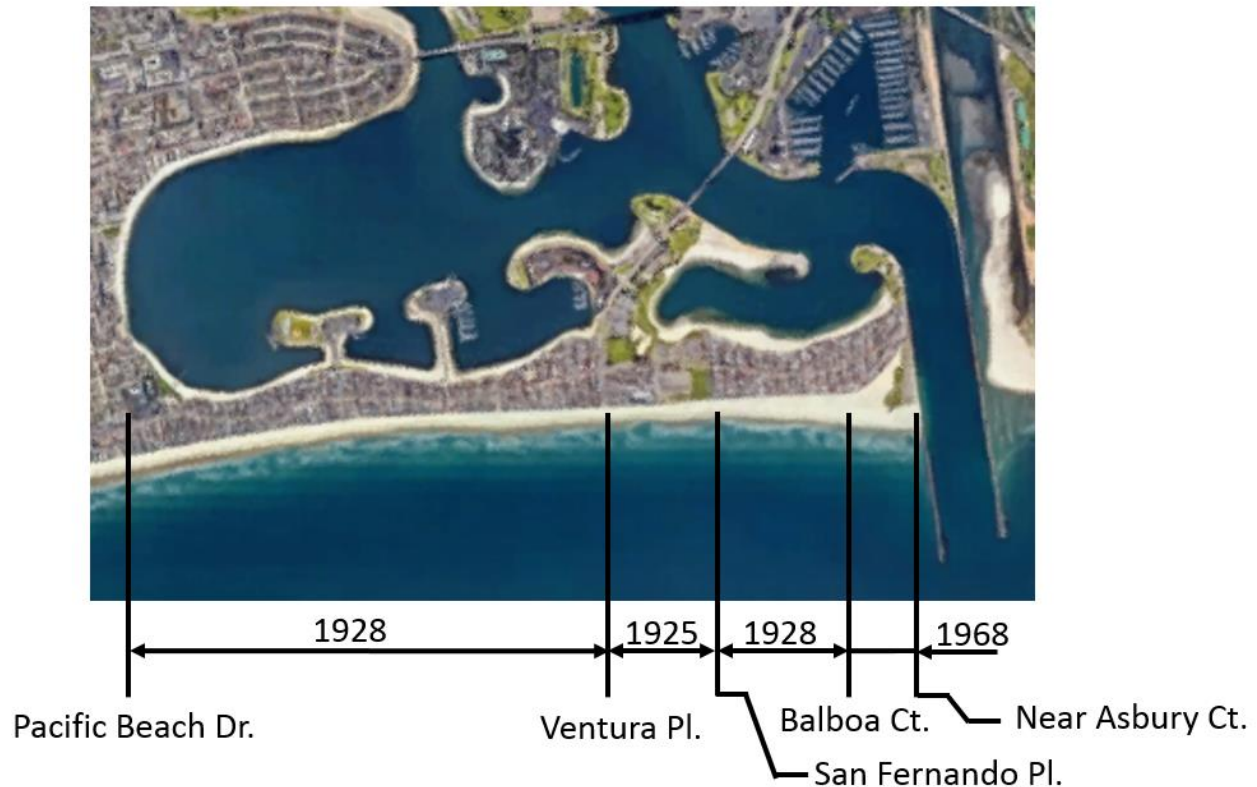

Figure 1-3. Project Location



**Figure 1-4. Original Seawall Construction Phasing**

### 1.3 Project Goals and Objectives

Feasibility for several improvements to the Mission Beach Seawall are studied in this report to address the age, condition, safety and functionality of the existing seawall and boardwalk. The study includes replacement of the parapet on top of the seawall, a new wall segment between Thomas Avenue and Grand Avenue, upgrade of existing beach access points, and a new vehicular beach access point. The work includes conceptual plans, ROM cost estimates, and a feasibility report summarizing design concepts and an assessment of the existing conditions.

City Charter section 55.2 prioritizes “Restoration of shoreline treatments within the Mission Bay Park Improvement Zone including restoration of beach sand and stabilization of erosion control features.” This project is led by the City of San Diego, with input from local stakeholders and resource agencies.

Since its construction between the 1920s and 1960s, broader Mission Bay Park (including the Pacific Oceanfront beach) has experienced coastal erosion and increased vulnerability of upland assets. This has led to an extensive beach maintenance program throughout the Bay Park area, as identified in the Mission Bay Park Natural Resource Management Plan (1990). The City of San Diego maintains Mission Bay Park shoreline areas for safety, sanitation, and shoreline stabilization reasons.

## 2.0 Data Collection and Existing Characteristics

### 2.1 Topography/Bathymetry

For preparation of the seawall conceptual design, topography files were merged to create a topographic file. The topographic file was sourced from the U.S. Geological Survey 2014 LiDAR survey. It should be noted that topographic data were obtained in the NAVD88 vertical coordinate system and converted into NGVD29 for the purposes of design.

### 2.2 Available GIS Data

Geographic information system (GIS) data were collected from San Diego Geographic Information Source (SanGIS) and reviewed for information regarding land use and utilities in the area (Table 2-1). The utility data from SanGIS were analyzed to determine whether any existing utilities cross the proposed project areas. A detailed survey of existing utilities is recommended prior to any final engineering design for the project area.

**Table 2-1. SanGIS Data Inventory**

Data Layer	Version Date	Source (Agency)
LiDAR	2014	SanGIS, San Diego Association of Governments (SANDAG), National Geospatial-Intelligence Agency (NGA), Law Enforcement Coordinating Council (LECC), Regional Public Safety GIS, 18 Incorporated Cities
Aerial Imagery	September 14, 2011	City of San Diego
Storm Drain Network Files (Drain Conveyance, Drain Structures)	October 17, 2018	City of San Diego, SanGIS, SANDAG
Land Use	January 1, 2017	SanGIS, SANDAG
Parcel Layer	February 15, 2018	SanGIS, SANDAG, Assessor/Recorder/County Clerk
Floodplain Layers	April 7, 2016	Federal Emergency Management Agency (FEMA)
Utility Layers (Sewer Main, Water Main, Storm Drainage)	March 5, 2018	SanGIS, City of San Diego Public Utilities Department, SANDAG

### 2.3 As-builts

As-built drawings relevant to the project were obtained from the City. A summary of the as-built plans reviewed is provided in Table 2-2.

**Table 2-2. Summary of City of San Diego As-Built Drawings Reviewed**

<b>Author</b>	<b>Completion Date</b>	<b>Title</b>	<b>Data Obtained</b>
City of San Diego	1934	Elevation & Sections of Parapet over Seawall at Mission Beach for Mission Beach, CA. Prepared by Lincoln Rogers and F.W. Stevenson.	Original drawings show extent from Balboa Pl to Pacific Beach Dr, with concrete sheet pile driven into bedrock. Constructed in the 1920s.
City of San Diego	2000	Plans for the Ocean Front Walk Repair between Thomas Ave. & Pacific Beach Drive. Prepared by Simon Wong Engineering.	Plans show repair of the extension of the bulkhead from Pacific Beach Dr to Thomas Ave, approximately 1,000 ft. Repair includes complete seawall replacement, including steel sheet pile and concrete cap.
City of San Diego	2000	Mission Beach Boardwalk Widening Ph 1A (Ventura Place to Santa Barbara Place). Prepared by Jamal S. Batta.	Plans for boardwalk widening along approximately 750 ft. Project adds 9 ft of width interior to existing boardwalk.
City of San Diego	2003	Mission Beach Boardwalk Bulkhead Preservation (Liverpool Court to El Carmel Place). Prepared by Jamal S. Batta.	Bulkhead preservation comprises demolition of concrete slab, backfilling subgrade and replacing slab. Project reach from Liverpool Ct to El Carmel Pl, about 380 ft.
City of San Diego	2006	Mission Beach Boardwalk Bulkhead Preservation (El Carmel Place to Nantasket Court). Prepared by Jamal S. Batta.	Bulkhead preservation comprises demolition of concrete slab, backfilling subgrade and replacing slab. Project reach from El Carmel Pl to Nantasket Court, about 560 ft.
City of San Diego	2015	Mission Beach Boardwalk Bulkhead Project Phase 1 & 2. Phase 1 Between San Fernando Place and the Belmont Park Comfort Station. Phase 2 Between Ventura Street and the Belmont Park Comfort Station. Prepared by RBF Consulting.	Repaired the 3 ft high parapet wall, including void filling and slab repairs, and added access stair pop-outs between bulkhead and beach. Project reach from San Fernando Pl to Belmont Park Comfort Station, and Belmont Park Comfort Station to Ventura Place, about 1,700 ft.

## 2.4 Project Datum and Units

The vertical and horizontal datums used for this study are the National Geodetic Vertical Datum 1929 (NGVD29) and the California State Plane Coordinate System (NAD83) Zone VI.

All units used in planning, design, and drawings are shown in Imperial units unless otherwise specified.

## 3.0 Existing Conditions

Over time, the seawall has undergone numerous modifications and repairs. Several seawall and boardwalk “Integrity Study” reports have assessed the condition of the seawall (Testing Engineers – San Diego, 1998, Daniel McNaughton and Associates, 1998, Subsurface Surveys, 1998, Harris & Associates, 2012, and TerraCosta Consulting Group, 2019). The most recent study by TerraCosta Consulting Group (2019) summarizes the site investigations and observations and provides recommendations for repair work. Based on the severity of damage and potential of public health and safety hazards, the recommendations for improvement were prioritized into phases. From the report, damages included but are not limited to:

- Cracks and spalls of concrete parapet wall and pile cap
- Exposed steel reinforcement bars, some reinforcing bars already corroded
- Voids below walkway creating pavement distress and settlement issues

Based on these findings, high priority repair work was identified at the seawall segment and walkway in front of Belmont Park, which relates to the 1925 wall section. Improvement was completed there in 2015 and included replacement of the parapet wall, pile cap, and walkway. This project is referred to as the 2015 Improvement Project in this document.

### 3.1 Mission Beach Seawall

The Mission Beach Boardwalk Seawall is comprised of three components: 1) a tied back concrete sheet pile structure, 2) a parapet wall, and 3) a walkway. Depending on the year of construction, the seawall design varies between the various phases. Each prior design and construction phase is summarized below.

- 1925 Boardwalk Seawall (Figure 3-1) – The seawall consists of precast reinforced concrete sheet pile walls interlocked continuously. The sheet piles are monolithically connected into a reinforced concrete pile cap with a curved face that serves as a wave reflector. The sheet piles are tied back to a reinforced concrete deadman by a concrete encased steel bar. A cast-in-place concrete parapet wall is anchored into the pile cap with vertical reinforcing bars. The walkway is supported on earthen fill with one edge sitting on a portion of the pile cap but without any connection (no reinforcing bars connecting the two elements).
- 1928 Boardwalk Seawall (Figure 3-2) – The seawall consists of a different sized precast reinforced concrete sheet pile wall than the 1925 version and with continuous interlock. The tie back system includes a square reinforced concrete beam that anchors back into a square reinforced concrete pile. Both the concrete beam and pile are spaced every 12'-0" on center. The pile cap, wave reflector, and parapet wall are similar to the 1925 wall. Unlike the 1925 wall section, the walkway was designed and connected into the pile cap.
- 1968 Boardwalk Seawall (Figure 3-3) – The seawall is a continuous reinforced concrete retaining wall that is backfilled with earthen fill. The parapet wall is similar to the 1925 and 1928 wall. It is unknown if the walkway is connected directly to the top of wall.
- 2000 Boardwalk Seawall (Figure 3-4) – The seawall consists of continuous steel sheet piles with a reinforced concrete cap.

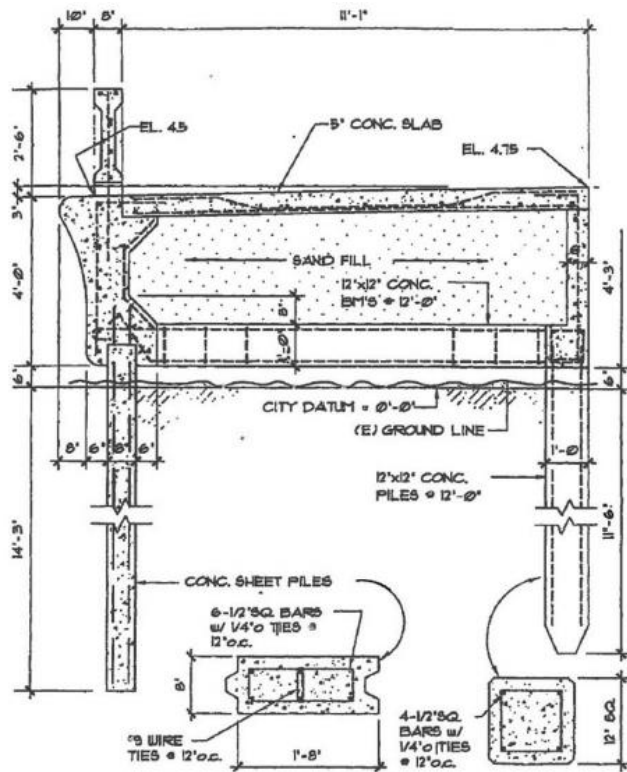

Figure 3-1. 1925 Seawall Section

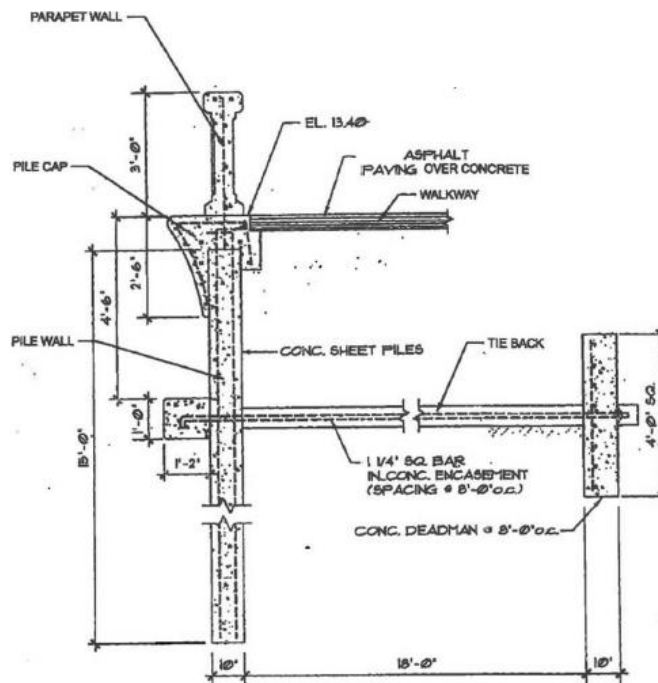

Figure 3-2. 1928 Seawall Section

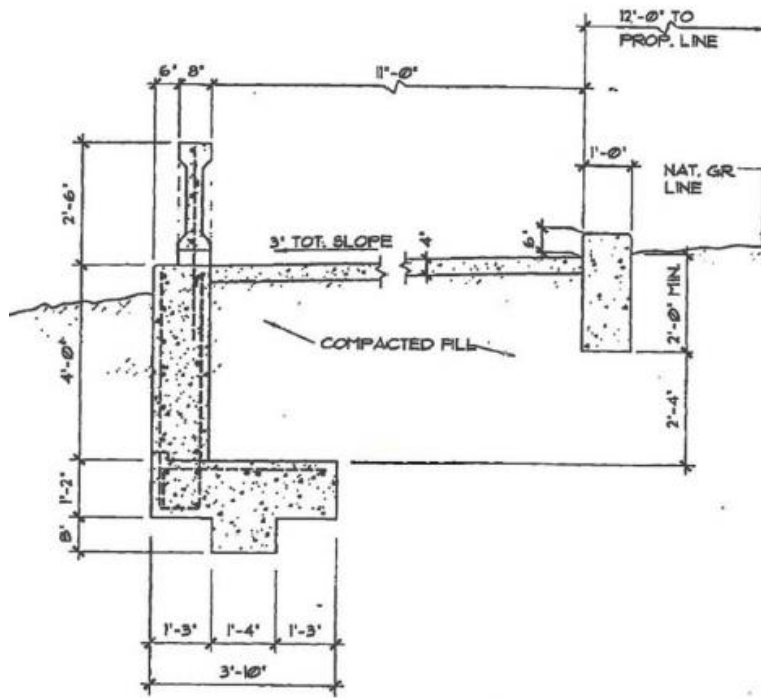

Figure 3-3. 1968 Seawall Section

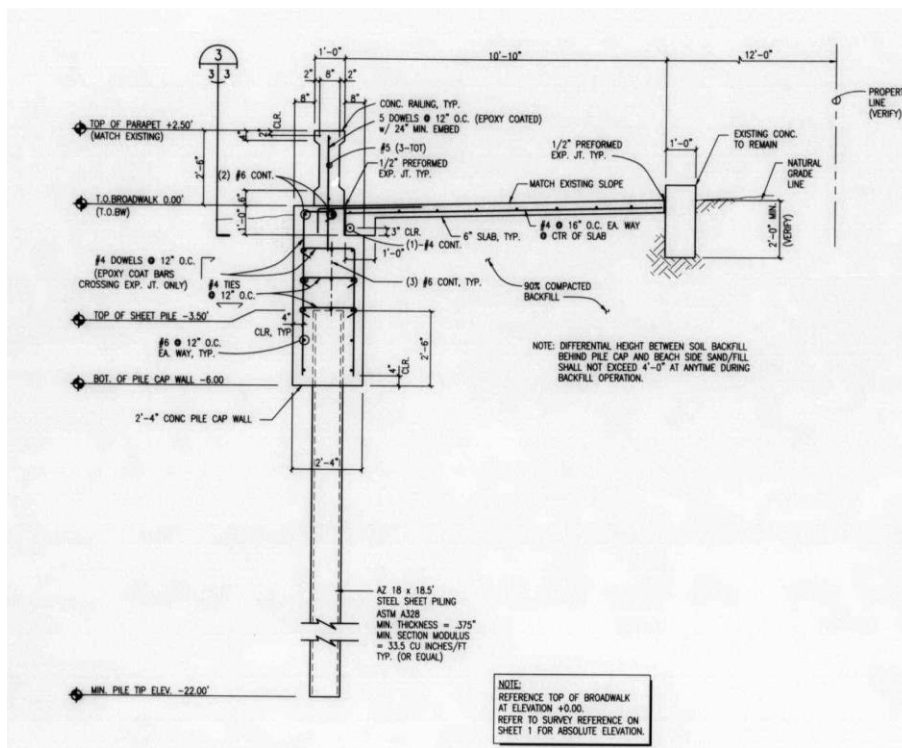

Figure 3-4. 2000 Seawall Section

## **3.2 Architectural Features for Historical Preservation**

During the 2015 Improvements, the project was subjected to a CEQA Section 15162 consistency evaluation promoted by the City Planning Department. This document serves as the guideline for the aesthetics and historical preservation features that repairs and new designs for any portion of the Mission Beach Boardwalk and Seawall would need to follow.

In accordance with the Technical Memo for the Mission Beach Seawall and Bulkhead (Dudek 2021), an emphasis on historical design is made regarding the balustrades and lamp post features of the historic structure. The historic openings of the balustrades are spaced 9" on center, and are 1'-3 1/2" tall, 4-1/2" wide and 8" deep. The lamp posts were incorporated into the parapet wall by segments of pilasters that are shorter than the typical wall height but with a larger cross section. At beach access locations, the pilasters are taller than the typical wall height.

Exposed surfaces of the seawall should be color matched to the historic look with a grade 1, light sand finish. In detailing the parapet wall, reveals should be incorporated to provide a depth dimension to the wall.

## **3.3 Oceanographic Conditions**

This section presents existing oceanographic conditions that affect project design. Additionally, project water level conditions are assessed with respect to SLR.

### **3.3.1 Astronomical Tides**

Astronomical tides are crucial to understanding daily inundation potential along the beach and in the bay and ramifications to seawall design. Still water level (SWL) is defined as average water surface elevations at any instant, excluding local variation due to waves, wave run-up, and wave setup but including the contributions of tide, storm surge, and SLR. SWL for various tidal levels are presented in Table 3-1. The Mean Lower-Low Water (MLLW) elevation of 2.32 ft NGVD29 represents the change from sub-tidal to intertidal zones. Mean High Water (MHW) elevation of 2.28 ft NGVD29 represents the change from daily tidal wetting and drying to supra-tidal areas. The Highest Observed Tide (HOT) represents the extreme SWL scenario.

**Table 3-1. Existing Still Water Levels at Mission Beach (NOAA Station 9410230)**

<b>Datum</b>	<b>Abbreviation</b>	<b>Existing SWL (ft, NGVD29)</b>
Highest Observed Tide (11/25/2015)	HOT	5.49
Mean Higher-High Water	MHHW	3.00
Mean High Water	MHW	2.28
Mean Sea Level	MSL	0.41
National Geodetic Vertical Datum of 1929	NGVD29	0.00
Mean Low Water	MLW	-1.42
North American Vertical Datum of 1988	NAVD88	-2.13
Mean Lower-Low Water	MLLW	-2.32
Lowest Observed Tide (12/17/1937)	LOT	-5.19
Mean Range of Tide (ft)		4.05
Greenwich High Water Interval (hrs)		5.01
Greenwich Low Water Interval (hrs)		11.07

### 3.3.2 Sea Level Rise

#### 3.3.2.1 What is Sea Level Rise?

Anticipated changes in climate and sea level are a result of increasing greenhouse gases in the atmosphere over time due to emissions from burning of fossil fuels and natural sources. Greenhouse gases trap long-wave thermal radiation within the atmosphere. This causes warming of the Earth’s atmosphere, lands, and oceans, resulting in climate changes and SLR (IPCC, 2013). SLR science involves both global and local physical processes. Models are created based on science’s best understanding of atmospheric, oceanographic, and geological processes on global and local scales; therefore, models are dynamic and periodically updated to reflect changes. On a global level, the most recent SLR projections come from the International Panel on Climate Change’s Sixth Assessment Report (AR6) released in 2021.

At the state level, the California Coastal Commission (CCC, 2018) presently recommends using the best available science. The State of California Ocean Protection Council (OPC) Science Advisory Taskforce updated the best available science through the “Rising Seas in California – An Update on Sea Level Rise Science” report, released in April 2017. This report was then used to update the OPC’s State of California Sea-Level Rise Guidance in 2018. The 2018 Guidance projects SLR for multiple emissions scenarios and uses a probabilistic approach based on Kopp et al. 2014. For both low- and high-emission scenarios, a likely range was determined based on Kopp et al. 2014, which estimates a 66% probability that SLR will be within that range. For the low-emissions scenario, the likely range of SLR for 2100 is 1.1 ft to 2.5 ft, and for the high-emissions scenario, the likely range for 2100 is 1.8 ft to 3.6 ft. The OPC’s 2017 report and 2018 Guidance include a specific singular scenario called H++, which represents recent scientific findings of faster rates of SLR due to previously unknown glacial dynamics by Sweet et al. 2017, which predicts 10.2 ft by Year 2100. The likelihood of this scenario is unknown and is recommended by the OPC to be considered for long-term, high-stakes decisions (OPC, 2018).

Climate science is a constantly changing field, often with high degrees of uncertainty. In the case of California’s SLR, the OPC has high confidence in estimates for SLR to around year 2050, after which emissions scenarios cause predictions to diverge. Therefore, this assessment focuses on key sea levels based on the location and coastal dynamics of the project area to provide consistent reference points across scenarios and predictions. Planning for a varying degree of SLR can be challenging and requires continual or periodic updates based on the most recent predictions.

Owing to the dynamics of the processes associated with SLR and the progress of the science, the State issued draft Revised Guidance in 2024 for public comment. The projections for SLR have been slightly modified between the 2018 and draft 2024 guidance, but the more significant change pertains to use of H++ which is not being carried forward in 2024. Generally, the near-term projections for SLR to 2100 are slightly lower in the 2024 guidance, while they become very similar to 2018 guidance after 2100.

SLR projections and related project planning approaches presented in the 2024 guidance for the short SLR time horizon are based on discrete predictions over the next 30 years. This resulted in a smaller range of prediction values for a given time horizon compared to earlier reports. For example, 2018 guidance SLR projections for 2050 varied from 1.1 to 2.7 ft, a range of 19 inches of rise relative to year 2000 recorded oceanic water levels. However, the latest science, including findings from the International Panel of Climate Change (IPCC) Sixth Assessment Report (AR6) suggests a much narrower variability in SLR values by 2050 compared to AR5, from 0.5 to 1.2 ft, a range of only 8 inches in Figure 3-5 (IPCC, 2023). This reduction in variability from 2024 compared to 2018 OPC guidance primarily reflects a considerable decrease in the maximum expected SLR based on the most current understanding of sea level dynamics.

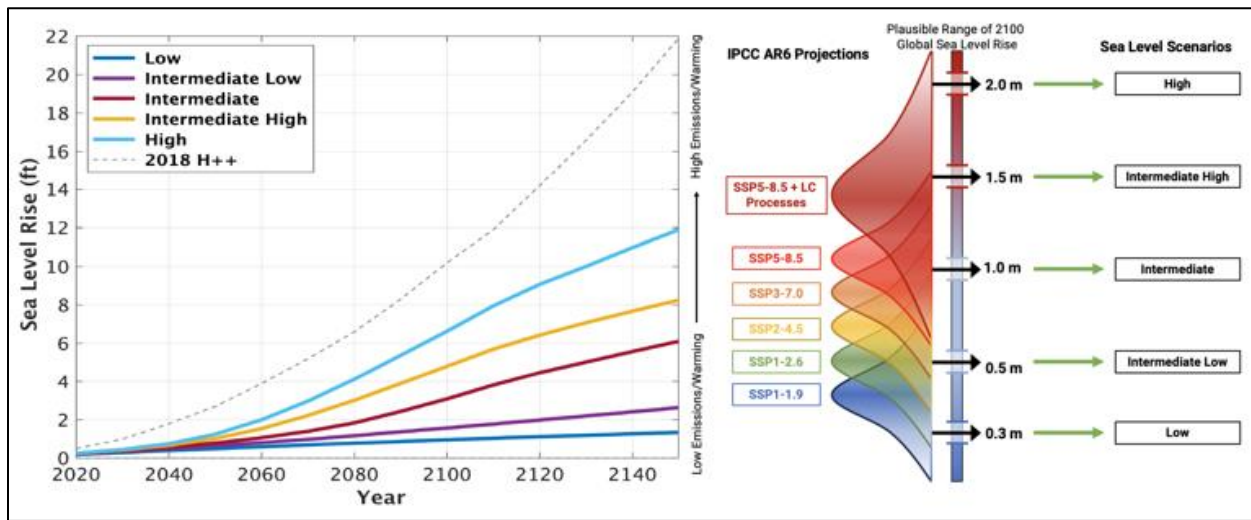

**Figure 3-5. Updated sea level scenarios from 2020 to 2150, in ft, relative to a baseline value of year 2000 recorded sea levels.**

The range of potential SLR broadens for mid- (2050-2100) and long-term (2100+) time horizons under the new guidance due to uncertainties in how different emissions scenarios and specific physical phenomena (e.g., the rapid melting of ice sheets) may affect future warming and sea level trends. By the end of the century and beyond, these uncertainties, especially those concerning ice sheet dynamics, contribute to a wider array of possible sea level variability. It is therefore recommended by the State Sea-Level Rise Collaborative in the 2024

updated policy guidance, in reference to Senate Bill 1, that long-term projections (e.g., beyond 2100) should be used with caution (Atkins, 2021).

**3.3.2.2 Selected Sea Level Rise Scenarios**

The current best available SLR science is the State of California OPC Science Advisory Taskforce April 2017 report and corresponding 2018 California State Guidance (OPC 2017 and OPC 2018). Projections for San Diego, CA, and by association Mission Beach and Bay, range widely with respect to greenhouse gas emission scenarios and probability. Projected SLR scenarios under the high emissions (i.e., worst case) scenario and varying probabilities are presented in Table 3-2 and **Error! Reference source not found.6**.

**Table 3-2.** Sea Level Rise Projections – San Diego, CA

Year	50% Probability SLR Scenario	17% Probability SLR Scenario	5% Probability SLR Scenario	0.5% Probability SLR Scenario	Extreme (H++) SLR Scenario
2030	0.5 ft	0.6 ft	0.7 ft	0.9 ft	1.1 ft
2050	0.9 ft	1.2 ft	1.4 ft	2.0 ft	2.8 ft
2100	2.6 ft	3.6 ft	4.5 ft	7.0 ft	10.2 ft

*(Adopted from OPC 2018, Table 34)*

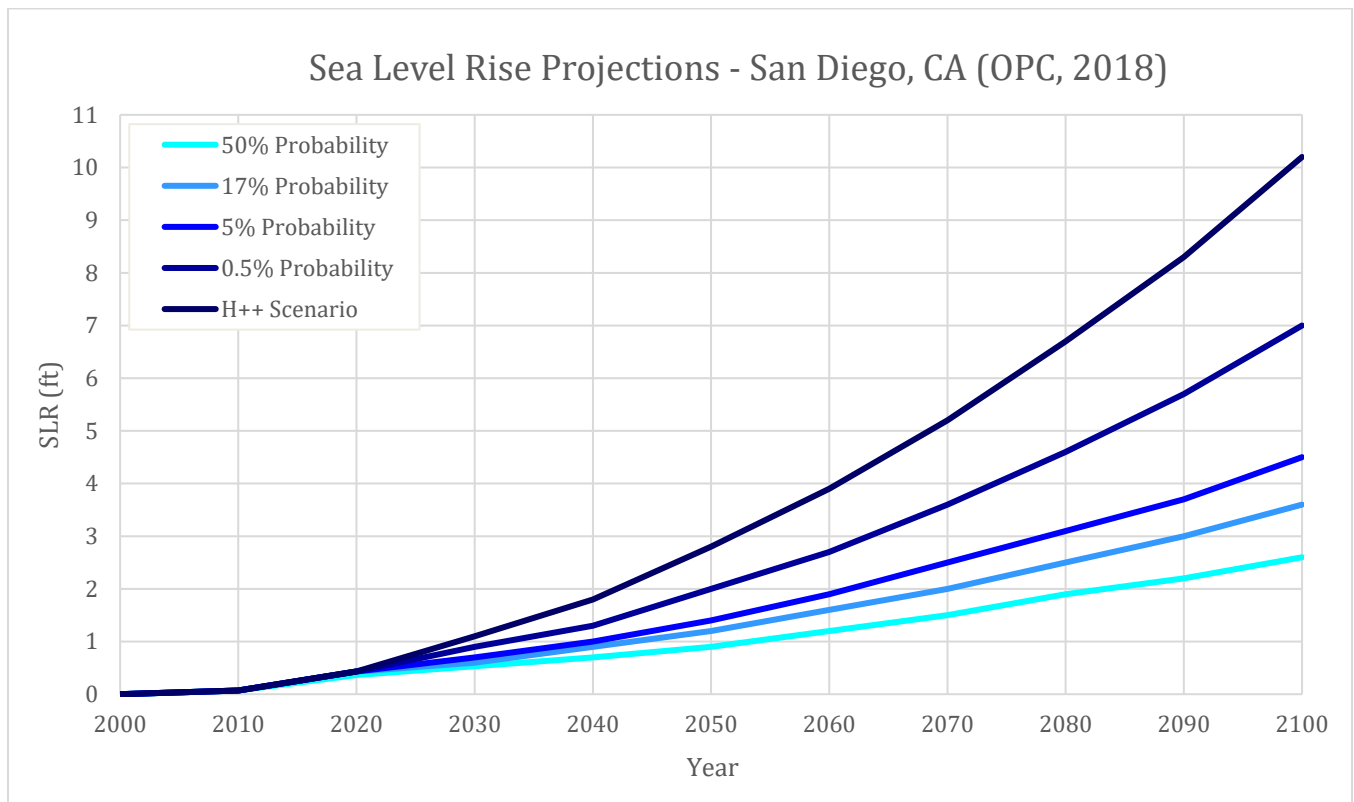

**Figure 3-6. Sea Level Rise Projections – San Diego, CA**

Due to the high degree of uncertainty associated with predicting when and at what rate SLR will occur, this study looks at a range of two scenarios that capture the range of predicted SLR rates and critical points for the study area. For the purposes of this study, the following two SLR scenarios are considered, as directed by the City:

- Low Scenario: 1.6 ft (0.5 meters)
- High Scenario: 4.9 ft (1.5 meters)

These two scenarios correspond approximately with the year 2050 with a 5% probability scenario and year 2100 with a 5% probability scenario, respectively (OPC, 2018).

### **3.3.3 FEMA Flood Maps**

The Federal Emergency Management Agency (FEMA) flood insurance rate maps (FIRMs) are considered for existing vulnerabilities at the Project site. Based on preliminary flood maps (provided in Appendix A), offshore of Mission Beach, the base flood elevation (BFE) reaches a maximum of approximately 18 ft NGVD29. The project flood conditions diminish as they approach the shoreline, and along Mission Beach, the BFE is approximately 12 to 13 ft NGVD29. FEMA estimates project flooding to reach, but not overtop, the existing seawall. The project site is identified as Special Flood Hazard Area Zone VE. The freeboard of coastal levees should be a minimum of 1 ft above the height of the BFE in this zone.

## 4.0 Preliminary Design

This section is intended to describe the preliminary design of the proposed seawall improvements, the probable construction estimate, and preliminary construction schedule.

### 4.1 Project Components

#### 4.1.1 Current Conditions

The seawall sections to be replaced were originally constructed in 1928, which include the continuous concrete sheet pile wall with monolithic pile cap, which is tied back with concrete beams supported on concrete piles. From the previous site investigation and observations report, this project's wall sections are generally in good condition, except the parapet wall. Concrete cracks and spalls are visible with areas showing exposed steel reinforcement. In some locations, rust is visible. With the seawall exposed to wave action and other water impact loading conditions, the wall gets contacted heavily with saltwater spray. Salt water contains chloride and sulfate ions that can attack the steel reinforcement causing corrosion. Rebar corrosion with concrete spalls affects the structural integrity of the wall; hence, there is a requirement for replacement.

Localized areas of voids below the walkway were also noted in the Harris & Associates 2012 Integrity Study. The voids were recommended to be filled between Nantasket Court and Pacific Beach Drive. The current project scope does not cover this work.

Further project site investigations were provided by TerraCosta Consulting Group (2019). The following is a summarized breakdown of TerraCosta's seawall condition observations by segment:

- Pacific Beach Drive to Ventura Place – This segment of wall was apparently built in 1928. This seawall is supported on 8-inch-thick by 20-inch-wide concrete sheet piles that extend to a below ground elevation of -14.25 feet (City Datum). The sheet piles are tied back to 12-inch square concrete piles by 12-inch square reinforced concrete beams spaced at 12 ft on center along the wall. The sheet piles are topped by a 4-ft-high, recurved concrete splash wall that is topped by a 33-inch-high parapet wall. The west side of the parapet wall was visible above sand level, and both wall sides exhibited areas of concrete spalling, cracking, and patching. A few areas of exposed rebar were noted.

The existing adjacent walkway is about 15-ft wide and was constructed by two phases of concrete placement. The west side of the walkway adjacent to the wall consists of older concrete placed in 1928. The walkway was widened, and the east side of the walkway consists of concrete placed in 1997. From Nantasket Court to Liverpool Court, the walkway was replaced and consists of concrete placed in 2005 and 2006. From Liverpool Court to Ventura Place, the concrete walkway was replaced in 1990. Localized areas of cracking and spalling of the concrete walkway were observed. Patching of the walkway consisted of concrete and asphalt materials. Voids under this segment of walkway were detected by geophysical surveys and coring of the concrete and were reported in previous reports for the project. Pounded water was noted on the sidewalk against the wall after a January 2019 "king" high tide and after episodes of rainfall.

- San Fernando Place to Balboa Court – This section of seawall was apparently built in 1928. This seawall segment is similar in construction to the seawall segment from Pacific Beach Drive to Ventura Place. This seawall is supported on 8-inch-thick by 20-inch-wide concrete sheet piles that extend to a below

ground elevation of -14.25 feet (City Datum). The sheet piles are tied back to 12-inch square concrete piles by 12-inch square reinforced concrete beams spaced at 12 ft on center along the wall. The sheet piles are topped by a 4-ft-high, recurved concrete splash wall that is topped by a 33-inch-high parapet wall. The west side of the parapet wall was visible above sand level and both wall sides exhibited areas of concrete spalling, cracking, and patching. A few areas of exposed rebar were noted. Localized areas of cracking and spalling of the adjacent concrete walkway were observed. Patching of the walkway consisted of concrete and asphalt materials. The original walkway was replaced in 1989. The Subsurface Surveys' 1998 report indicates that there are no voids under this segment of the walkway. Pounded water was noted on the sidewalk against the wall after a January 2019 episode of rainfall.

#### **4.1.2 Concept Design Options**

Several seawall improvements are included in this study and presented below. Refer to the preliminary drawings (Appendix B) for engineering concept details.

Improvements along three main segments of wall were considered. The segments were grouped based on their structural cross section.

- Segment A: Balboa Court to Pacific Beach Drive (excluding wall in front of Belmont Park)
- Segment B: Pacific Beach Drive to Thomas Avenue
- Segment C: Thomas Avenue to Grand Avenue

In addition, several improvements to beach access infrastructure were studied:

- Beach Access Stairs (modify existing to be code-compliant)
- Beach Access ADA Ramp (convert existing stairs to ramp)
- Beach Access Driveway at Thomas Avenue for City equipment

The sand level adjacent to the boardwalk can drop more than 30-inches, meaning 42-inch-high fall protection must be provided on the west edge of the boardwalk for public safety. For this reason, the proposed typical parapet height is 42-inches, which will be 6 to 12-inches higher than the existing parapet.

The open balustrades constructed for the new Belmont Park wall segment provide a nice aesthetic feature but provide a pathway for wave runup through the wall and are therefore detrimental to the protection provided by the wall. For this reason, the proposed parapet wall will be solid with no gaps, but will be formed with reveals to meet requirements for historic preservation.

Over time, the original lamp posts were taken down on the western side of the boardwalk (i.e., at the pilasters) and were moved to the eastern side of the boardwalk. The intent is to keep the boardwalk lighting as-is, so pilasters are not required for the replacement parapet. The new parapet will be required to be color-matched with the previous improvements.

New structures are typically designed for a 75-year service life. Design of the new structural components should take into account considerations such as materials, structural detailing, and long-term maintenance to provide the appropriate service life.

Concept drawings for each of the options studied can be found in Appendix B. The preliminary opinion of probable construction cost is provided in Appendix C, with summary tables provided in Section 4.2. The cost

estimates were developed using direct experience and knowledge based on similar items and projects, vendor quotes from recent projects for similar items, contractor quotes from recent similar work, and other historical cost information that is available.

#### **4.1.2.1 Segment A: Balboa Court to Pacific Beach Drive**

Segment A runs from Balboa Court to Pacific Beach Drive. The segment in front of Belmont Park between San Fernando Place and Ventura Place was restored in 2015 and is not part of this project. The total length of Segment A within the limits of this project is approximately 8,760-feet.

Two options were studied for replacing the deteriorated parapet along Segment A. In Option 1, the existing parapet would be replaced by a new 42-inch parapet. Void filling below the boardwalk is also addressed in a cursory level of detail as Option 1A. In Option 2, the boardwalk would be raised to address sea level rise, and a new 48-inch parapet would be constructed on top of the raised boardwalk.

##### **4.1.2.1.1 Segment A: Option 1 – Parapet Replacement**

Segment A: Option 1 would replace the existing 30 to 36-inch parapet with a new 42-inch parapet, shown in Figure 4-1. In addition to providing the necessary fall protection, the increased parapet height would also provide SLR resiliency. The modified replacement-in-kind design would tie in with the overall look of the Mission Beach Boardwalk. This would provide resilience for SLR of up to between 6 and 12 inches, which is projected to occur sometime between 2030 and 2040 according to 2018 State SLR Guidance or between 2040 to 2050 according to 2024 Draft State SLR Guidance.

The existing parapet would be demolished to the top of the concrete pile cap. The new parapet would be cast-in-place concrete and would be doweled into the existing pile cap through vertical reinforcing bars. The existing sheet pile wall and tie back system is assumed to be adequate to carry loading from the new parapet and would remain as-is.

Temporary fencing along the length of boardwalk would be used to allow a portion of the boardwalk width to remain open during construction. Work is assumed to be performed from the beach side to minimize disruptions along the boardwalk. The duration of construction is estimated to be eleven (11) months.

The ROM cost to replace the parapet along the 8,760-foot Segment A is \$5,126,000 (\$585 per linear foot of wall); see Appendix C for additional information.

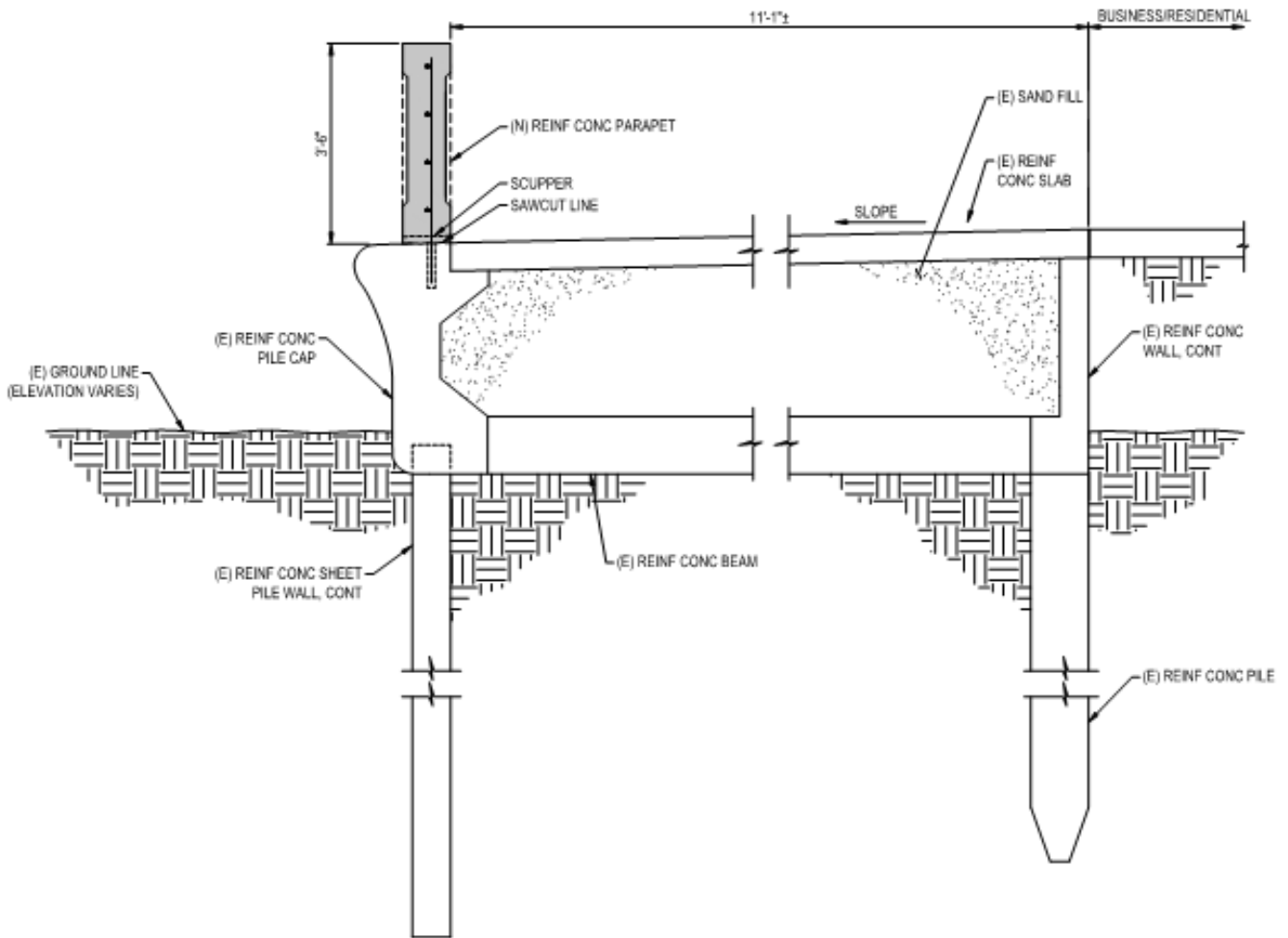

**Figure 4-1. Segment A - Option 1 - Parapet Modified Replacement-in-Kind**

4.1.2.1.2 Segment A: Option 1A – Typical Void Repair Under Walkway

A second potential component to restoring the existing seawall in Segment A: Option 1 is filling of the voids below the existing walkway as option 1A. The voids are the result of sand passing through the joints in the sheet piles over the years when the beach sand levels have dropped. These voids have been documented in several reports and over several years (Testing Engineers – San Diego, 1998; Harris & Associates, 2012; TerraCosta Consulting Group, 2019). The primary area of concern for voids is between Nantasket Street and Pacific Beach Drive, a stretch of wall approximately 4,000-feet in length. The 2012 Simon Wong Engineering report noted that the voids between El Carmel Drive and Nantasket Court were filled and the walkway was replaced in 2006. Approximate void locations are shown on the drawings based on a boardwalk 1998 integrity study (Geotechnics 1998) and a 2012 integrity study (Simon Wong 2012).

There are two components to addressing the voids under the sidewalk:

1. Fill the voids
2. Seal the joints between sheet piles to prevent future voids from occurring

The City prefers to address the voids using the method with least impacts to the public. For this reason, the void repair strategy shown in the concept drawings (Appendix B) and cost estimate (Appendix C) would be to core holes in the sidewalk and fill the voids with grout. Note that additional voids along the boardwalk may be present. As TerraCosta describes in their Geotechnical Recommendations report (TerraCosta 2022):

*We recommend coring the existing walkway pavement where known voids are located. A grout mix may be injected into the space below the walkway to fill voids and limit further distress on the existing walkway pavement. Because ten years have passed since the previous investigation, additional voids may now be present. We recommend additional geophysical testing, such as ground penetrating radar, to locate existing voids.*

The Geotechnical Recommendations report goes on to note that this method would not remediate breaches in the seawall that are causing the voids to occur, and future voids should be expected to form.

In order to prevent future voids from occurring, significant additional work would be required to seal the joints between the sheet piles. This could be done as described in the Geotechnical Recommendations report by removing the walkway pavement and excavating the wall backfill to locate breaches, then injecting a grout mix to fill the breaches. Another option would be to seal the joints from the front face of wall by excavating the front face of wall down to the lowest known scour elevation, installing a plastic sheet pile and waler system on the front face of wall and filling the annular space with grout to seal the joints. Further analysis for repairing the seawall in this manner is beyond the scope of this study.

The ROM cost to temporarily repair the voids below the sidewalk by filling with grout for a 4,000-foot wall segment is \$582,000 (\$146 per linear foot of wall); see Figure 4-2 and Appendix C for additional information. The duration of construction is estimated to be three (3) months. The ROM cost estimate considers the temporary void repair as a standalone item not necessarily completed at the same time as the concrete parapet replacement (Section 4.1.2.1.1). If the temporary void repair work were to occur at the same time as the parapet replacement, there would be efficiencies in mobilization, traffic control, and temporary fencing that would result in cost savings.

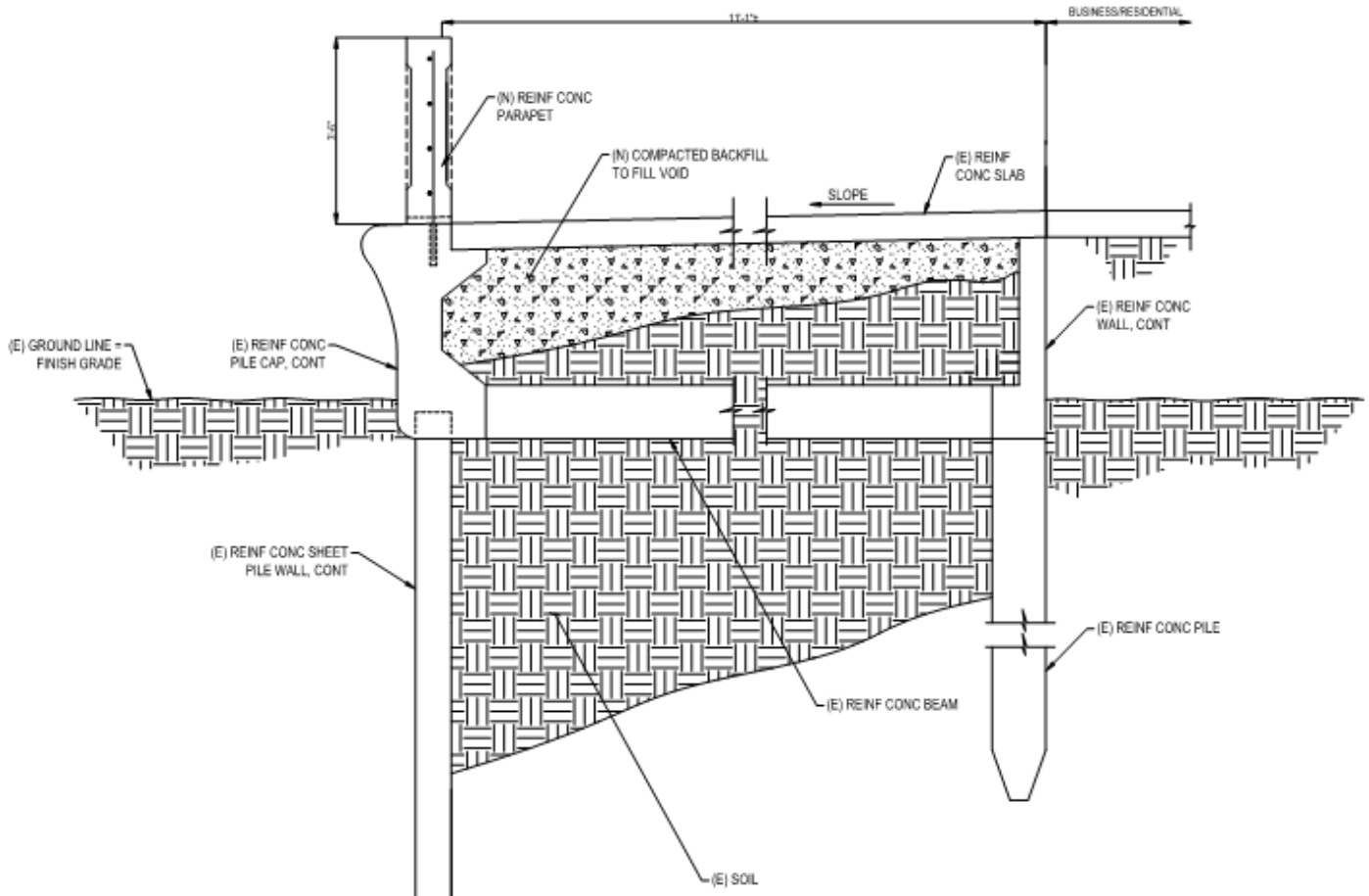

**Figure 4-2. Segment A - Typical Void Repair Under Walkway**

#### 4.1.2.1.3 Segment A: Option 2 – Raised Boardwalk

The second option for parapet replacement accounts for the required wall height to accommodate impacts related to SLR. For a SLR of 1.6-feet, the top of parapet elevation would need to increase by 3.5-feet to reduce water overtopping from high tides, storm surges, and other storm flood-related events (see Section 5.2.9). Increasing the parapet height by 3.5-feet was ruled out because it would increase the total wall height to 6-feet, which would drastically reduce the line of sight to the ocean for businesses, homeowners, and users of the boardwalk.

Instead, the proposed Option 2 improvements would raise the entire boardwalk 2-feet and increase the parapet height to 48-inches. The total increase in elevation for the top of parapet would be 3.5-ft. The increase in weight due to the added height would require a deeper concrete tie beam and backwall, as shown in Figure 4-3. Reconstruction of the boardwalk would allow the voids below the sidewalk to be filled with compacted material. Though this would fill the voids, it would not prevent them from continuing to occur, as discussed in Section 4.1.2.1.2. Additional steps would be required to prevent loss of the backfill.

The substructure elements (sheet pile wall and pile) would still be adequate with the increase in load, therefore these elements would not need to be replaced. The parapet wall and most of the pile cap would be demolished, along with the walkway and in-fill below, and a portion of the backwall. The new seawall system and walkway would be placed and connected to the existing pile cap, tie back beam, and backwall through vertical reinforcing bars. The parapet would be formed to meet the architectural requirements for historical preservation.

The cost for this option along the 8,760-foot length of Segment A is \$18,350,000 (\$2,095 per linear foot of wall); see Appendix C for additional information. The duration of construction is estimated to be twenty-five (25) months. The cost does not include any protective measures for private residences and businesses adjacent to the boardwalk and does not include any phasing requirements at the project limits (i.e., the ramp or steps would be required to tie into the existing boardwalk).

Although this design provides the resiliency to adapt to SLR, this option has several issues. The raised walkway and wall height pose challenges with sightlines and accessibility. Construction of the raised boardwalk would require full-width closure of the boardwalk during construction. This option is also significantly more costly than Segment A: Option 1. It is understood that due to these challenges, the City does not wish to pursue this option.

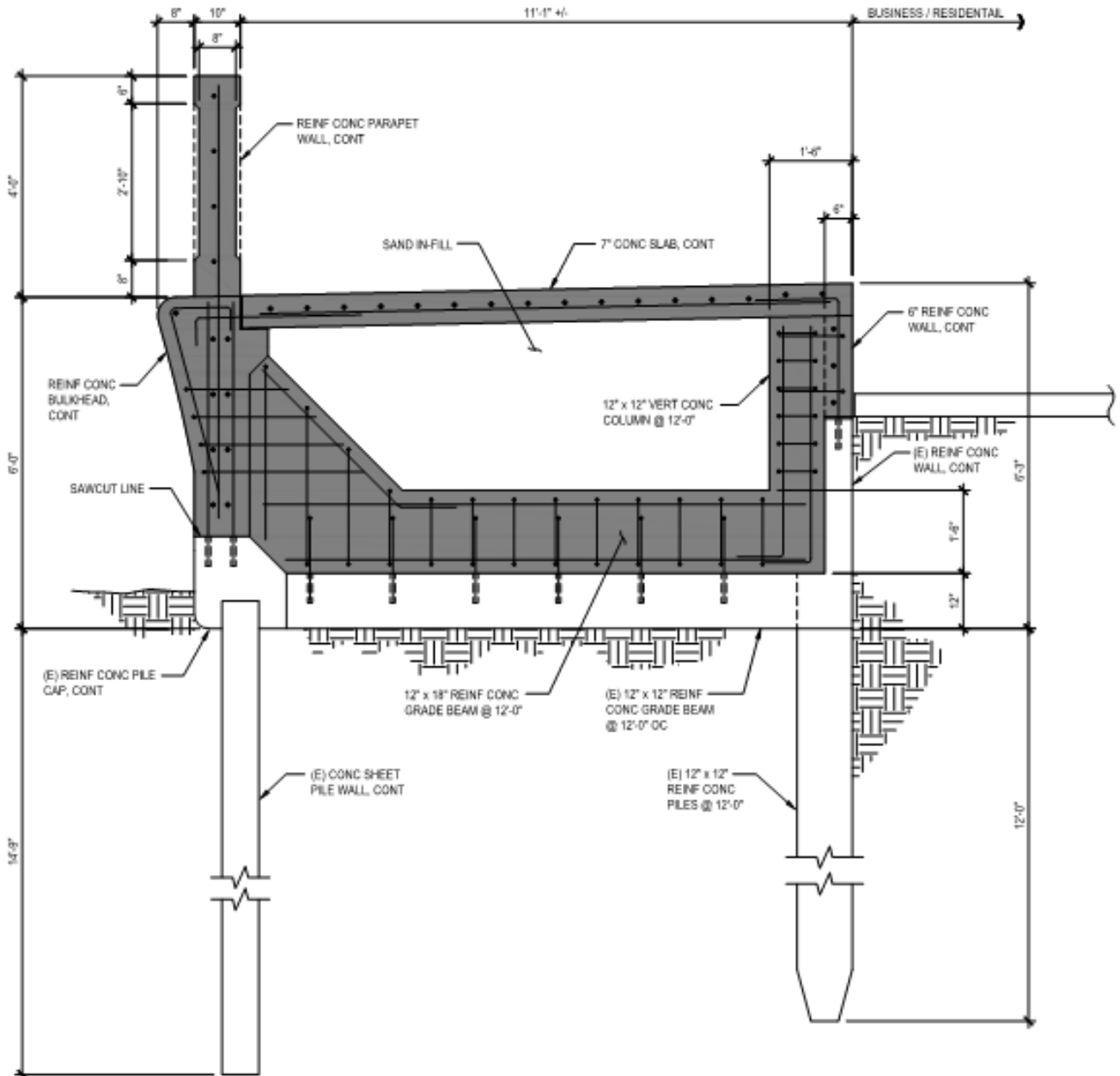

**Figure 4-3. Segment A - Option 2 - Raised Boardwalk**

#### 4.1.2.2 Segment B: Pacific Beach Drive to Thomas Avenue

##### 4.1.2.2.1 Segment B: Parapet Replacement

Segment B runs from Pacific Beach Drive to Thomas Avenue and is approximately 1,020-feet in length. This segment of seawall was reconstructed in 2000 and has a different structural system than the Segment A wall (Figure 4-4). However, the proposed parapet will match the 42-in parapet proposed for Segment A: Option 1 and the scope of work will be similar. Due to anticipated challenges associated with Segment A - Option 2 as

discussed in Section 4.1.2.1.3, a raised boardwalk option was not considered for Segment 2. At the City's direction, replacing the existing parapet with a 42-in parapet was the only feasible option considered for Segment B.

The ROM cost to replace the parapet along the 1,020-foot Segment B is \$676,000 (\$663 per linear foot of wall); see Appendix C for additional information. The duration of construction is estimated to be 2.5 months. The ROM cost estimate assumes this work to be a standalone item (i.e., not completed at the same time as other repairs). Because the nature of this work is similar to Segment A: Option 1 – Parapet Replacement, the construction cost for Segment B would be reduced if the work were to be completed at the same time as the Segment A parapet replacement.

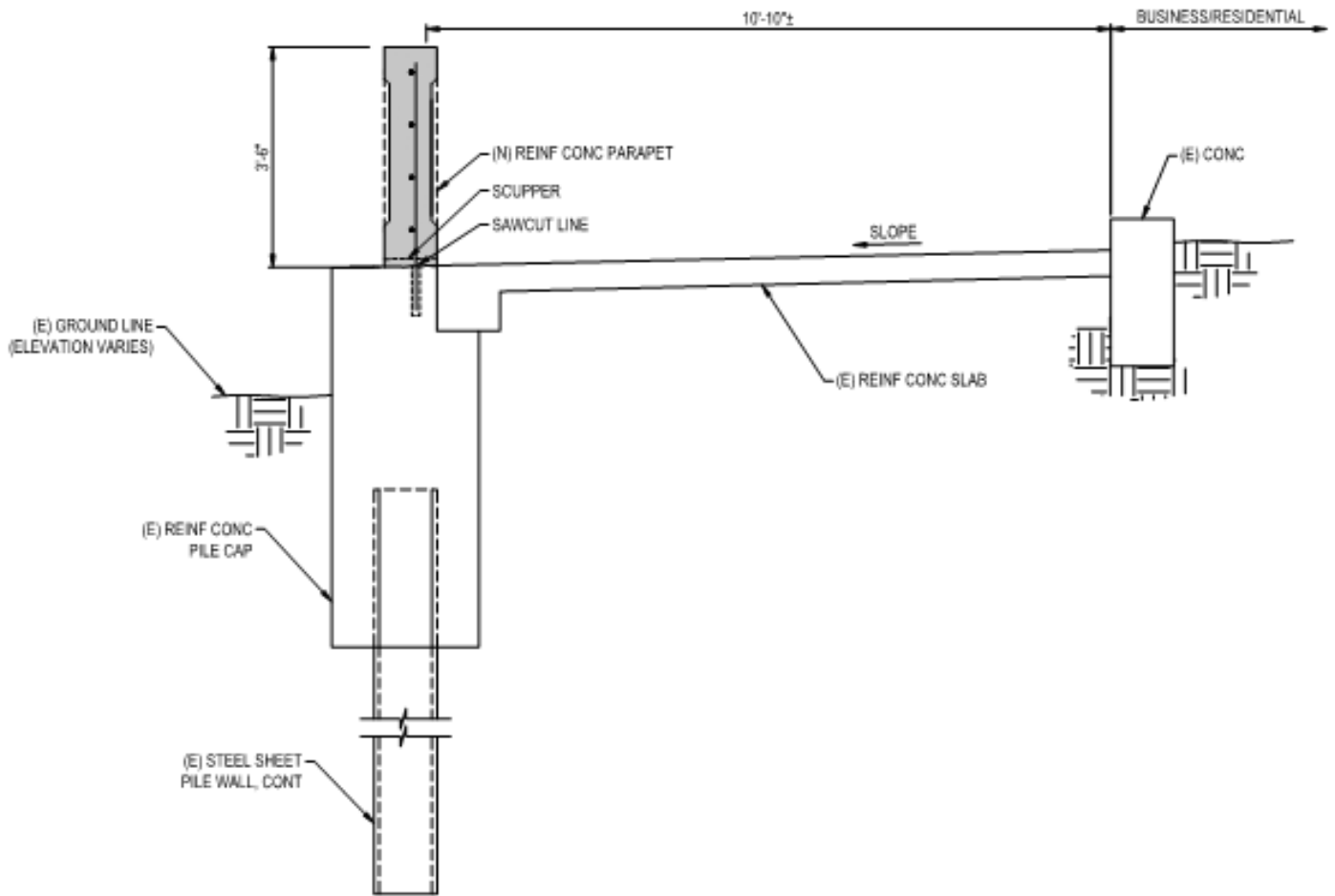

**Figure 4-4. Segment B - Parapet Replacement-in-Kind**

**4.1.2.3 Segment C: Thomas Avenue to Grand Avenue**

A proposed new segment of wall approximately 375-feet in length was studied between Thomas Avenue and Grand Avenue. No wall currently exists along this stretch of boardwalk, with K-rail separating the beach from

the sidewalk. A temporary sand berm is typically constructed during winter months to protect this segment of the boardwalk. A parking lot is adjacent to the boardwalk on the east side.

Five light poles located along the west edge of this segment of boardwalk would need to be relocated to construct the new wall. It is assumed the light poles would be mounted on the new parapet.

The existing 13-foot-wide Segment C boardwalk is proposed to be widened by 5-feet to a total width of approximately 18-feet. This would align the new wall segment with the approximate location of the existing K-rail. At the north end of Segment C, the new wall would tie in at the front edge of the existing flatwork for the shower near the lifeguard station. The added width would provide congestion relief in this heavily trafficked pedestrian area.

The City is currently considering two options for this segment. Option 1 would provide a new structural seawall that would protect the shoreline from wave action and storm surge, like other segments of the existing seawall. Option 2 would only provide a “decorative” wall to act as a pedestrian barrier between the boardwalk and beach - it would not provide coastal protection and would still require the City to use other measures (sand berm, etc.) to protect the boardwalk during storm events.

#### 4.1.2.3.1 Segment C: Option 1 – Seawall

Segment C: Option 1 would construct a new structural seawall along Segment C that would be designed to provide protection against coastal conditions, shown in Figure 4-5. The wall would be comprised of steel sheet piles with a reinforced concrete cap and parapet on top, similar to Segment B.

During construction, it may be possible to keep a portion of the boardwalk open while the sheet piles are installed. To construct the pile cap, however, excavation of the front and back face of wall approximately 4-feet deep would be necessary. It is assumed that the boardwalk would be closed during this portion of work and the pedestrian traffic would be shifted temporarily to the adjacent parking area. The existing sidewalk would be demolished and replaced by a new structural slab supported by the pile cap. The existing light poles would be relocated to pedestals mounted on the west side of the new parapet.

The ROM cost to construct a new 375-foot-long seawall along Segment C is \$1,396,000 (\$3,723 per linear foot of wall); see Appendix C for additional information. The duration of construction is estimated to be 3.5 months.

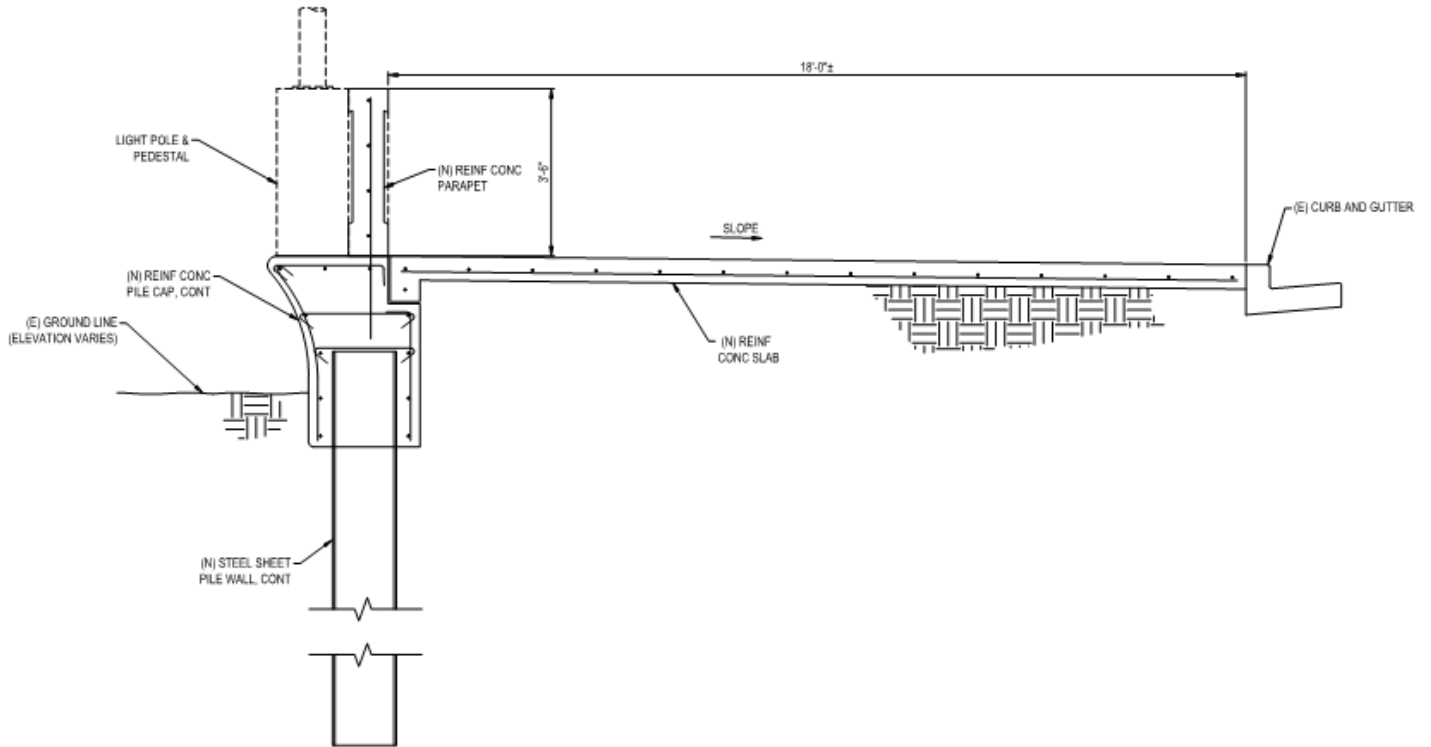

**Figure 4-5. Segment C - Option 1 - Seawall**

**4.1.2.3.2 Segment C: Option 2 – “Decorative” Wall**

Segment C: Option 2 would construct a “decorative” wall along the 375-foot length of Segment C, shown in Figure 4-6. This wall would be supported on a spread footing, rather than a deep pile foundation, meaning it would not be designed to resist storm and surge conditions that result in significant beach erosion and undermine the base of this wall.

In order for the wall to remain stable, the City would be required to maintain a minimum sand elevation, similar to a requirement of the 2015 Belmont Park project, which was used as guidance for this study. The City would likely need to continue constructing sand berms each winter season to maintain this sand level.

Construction of the wall would require closure of the boardwalk in order to provide the necessary clearance for wall footing excavation. Like Segment C: Option 1, it is assumed the adjacent parking lot could be used as a temporary pedestrian traffic detour during construction.

Though this wall would not provide the same level of coastal protection as Segment C: Option 1, it would provide continuity of the boardwalk parapet aesthetic, and would be an upgrade over the K-rail that is currently in place.

The ROM cost to construct a new 375-foot-long “decorative” wall along Segment C is \$925,000 (\$2,467 per linear foot of wall); see Appendix C for additional information. The duration of construction is estimated to be

three (3) months. The ROM cost estimate does not account for costs to construct winter sand berms or other protective measures that would be necessary to maintain the required sand level.

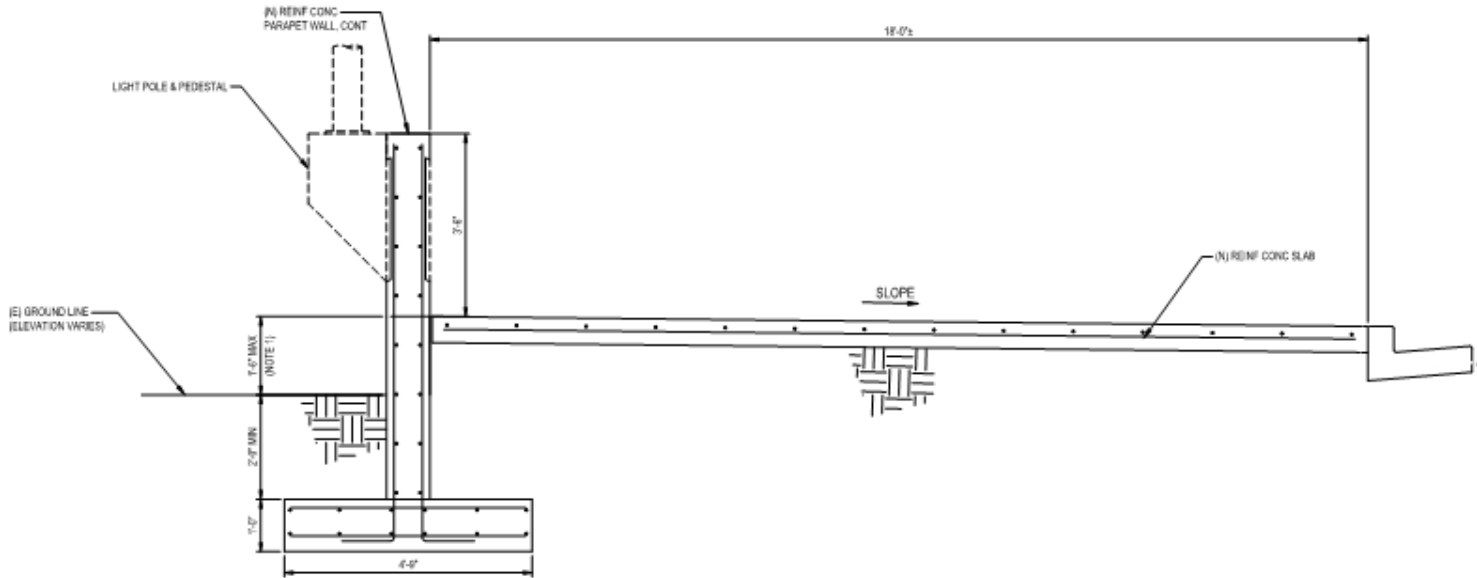

**Figure 4-6. Segment C - Option 2 - "Decorative" Wall**

#### 4.1.2.4 Pedestrian Beach Access Improvements

Pedestrian beach access along Segments A and B is currently provided by "pop-out" stairways at 14 locations, shown in Figure 4-7. The existing stairs are non-code compliant due to the insufficient top landing width and lack of fall protection and handrail. A general example of an existing stair section is shown in Figure 4-8; note that the existing stairways were constructed at different times, and the details shown in Figure 4-8 do not necessarily represent all stairway configurations along the boardwalk.



**Figure 4-7. Existing Pedestrian Beach Access Locations within Project Limits**

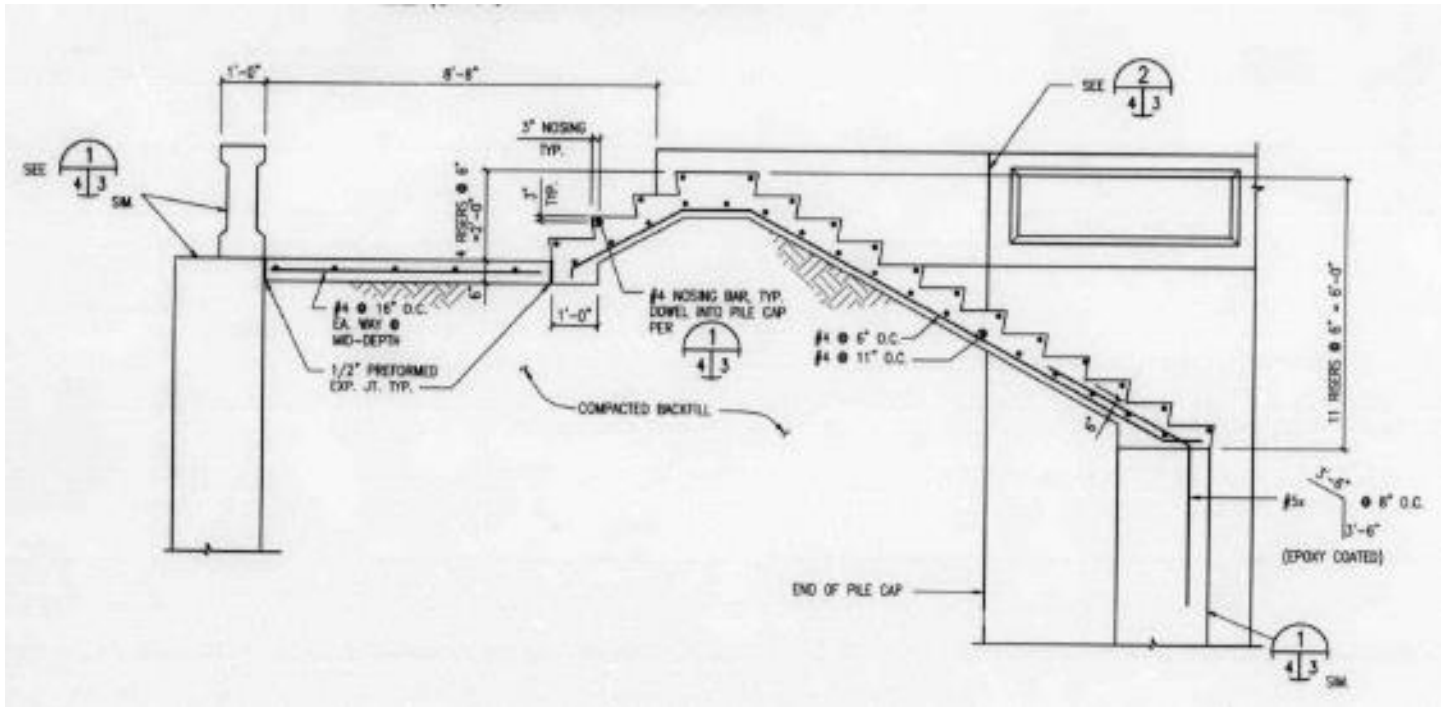

t

**Figure 4-8. Existing Stair Example (1999 plans)**

Two replacement options were studied: 1) Beach Access Stair and 2) Beach Access ADA Ramp. Following this study, the City intends to seek recommendations from an ADA consultant regarding which of the 14 existing stair locations should be reconstructed with stairs versus ramps.

The typical existing stairs rise 2-feet higher in elevation than the boardwalk before descending to the beach, which provides additional coastal protection to the boardwalk. Per the City's direction, the proposed stair and ramp configurations presented in this study will rise 2-feet before descending to provide the same level of protection as currently provided.

After a major storm event e.g. El Nino storm, the beach sand levels have potential to drop several feet, which creates a fall hazard at the beach access locations (similar to the boardwalk itself as discussed in Section 4.1.2). A picket guardrail with handrail is proposed for both the stair and ramp alternatives, with the guardrail rising 2-feet above the parapet at the peak to provide the necessary fall protection. The see-through guardrail is proposed as it will provide some visibility as opposed to a solid parapet wall.

#### 4.1.2.4.1 Beach Access Stairs

Many of the existing stairways would likely be replaced with new, code-compliant stairways, shown in Figure 4-9. Stair treads, width, landings, and railings would be designed to comply with City of San Diego 2018 Standard Drawing SDM-118.

The existing sheet piles supporting the stairs are assumed to be concrete in Segment A and steel in Segment B and could remain in place to support the new stairs. The stairs would rise 2-feet before descending to match the existing configuration. At the end of the stairway, an "L"-shaped segment of new sheet pile wall with

concrete cap would be constructed to lengthen the stairway to meet code requirements. The proposed stairs would descend to approximately EL 7.00 (NGVD 29), which is assumed to match the elevation of the bottom of existing stairs.

Each existing beach access location would be closed during construction; however, the boardwalk could remain partially open. The existing parapet along the stair pop-out would be demolished and reconstructed similar to the parapet replacement discussed in Segment A: Option 1 and Option 2. The new stairs would tie into the boardwalk parapet, and thus the replacement of the boardwalk parapet must occur prior to reconstruction of the stairs.

The ROM cost to reconstruct one (1) stairway is \$134,000; see Appendix C for additional information. This cost estimate assumes structural components of the existing stairway are re-used; as such, the ROM cost estimate provided herein should not be construed as the cost to construct a new stairway at a new beach access location. The duration to reconstruct one stairway is two (2) weeks.

The ROM cost is provided for reconstruction of one stairway; if multiple stairways were to be reconstructed at the same time, the cost per stairway would be reduced due to reduced mobilization costs and construction efficiencies.

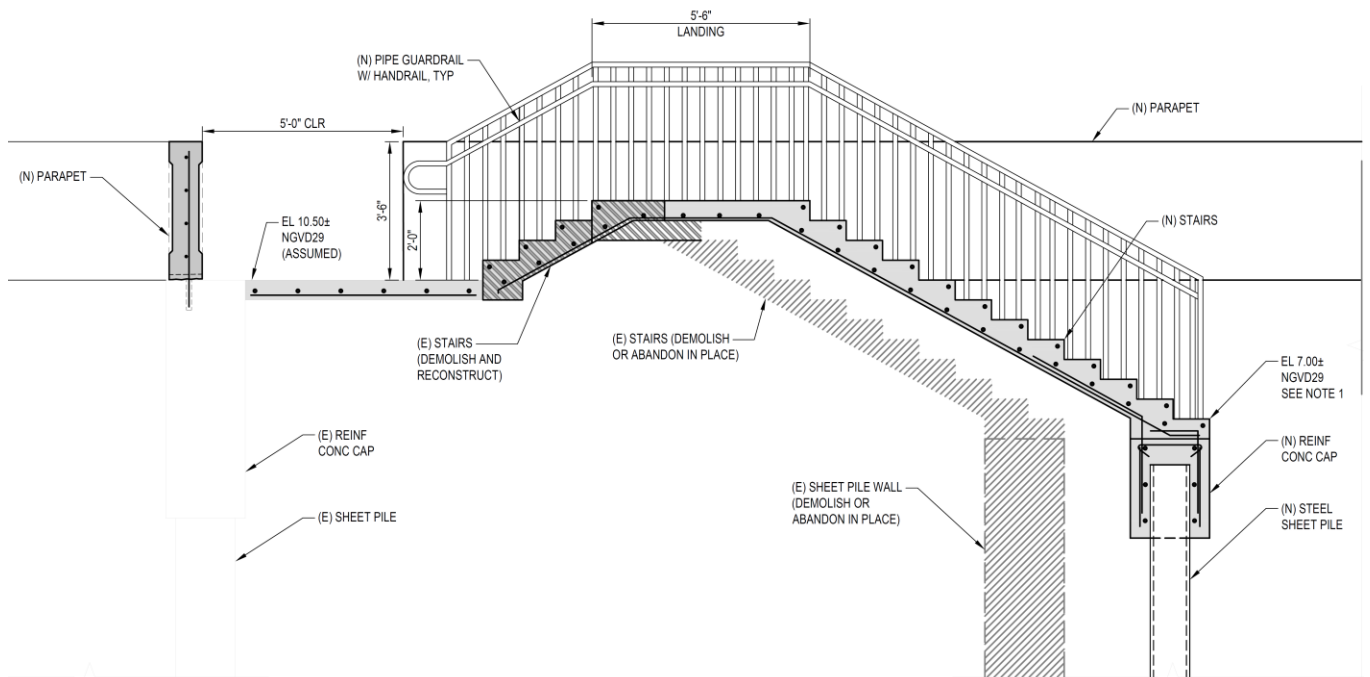

**Figure 4-9. Beach Access Stairs**

**4.1.2.4.2 Beach Access Pedestrian Ramp**

The second beach access alternative studied is an ADA-compliant pedestrian ramp (Figure 4-10) that would replace the existing beach access stairs at locations determined by the City. The ramp would slope at 1:13 (7.69%) maximum and provide landings for every 30-inch rise per the City of San Diego 2018 Standard Drawing

SDM-115. The ramp would also have a picket guardrail with handrail for fall protection. As discussed in Section 4.1.2.4 and per the City’s direction, the proposed ramp would rise 2-feet before descending to provide the same level of coastal protection currently provided.

The proposed bottom landing would be approximately 3-feet below top of boardwalk. This is assumed to be near the same elevation where the current stairs terminate and is the lowest the ramp can descend before requiring an additional landing.

A new sheet pile wall and pile cap would be constructed to extend the existing pop-out to the necessary length for the ramp. The new sheet pile wall for the stairway would tie into the existing sheet pile wall. The existing stairs would be demolished and replaced by the ADA ramp. The parapet along the existing segment of stair pop-out would be demolished and replaced. The new ramp would tie into the boardwalk parapet, therefore the replacement of the boardwalk parapet must occur prior to construction of the ramp. Aesthetically, the parapet wall for the ramp would look the same as the new parapet wall proposed for the boardwalk.

The ROM cost to construct one (1) pedestrian ramp is \$718,000; see Appendix C for additional information. This assumes structural components of the existing stairway are re-used; as such, the ROM cost estimate provided herein should not be construed as the cost to construct a new pedestrian ramp at a new beach access location. The duration of construction for one ramp is one (1) month.

Like the stair reconstruction cost estimate, the ramp ROM cost estimate represents the cost to construct one ramp. If multiple ramps were to be reconstructed at the same time, the cost per ramp would be reduced due to reduced mobilization costs and construction efficiencies.

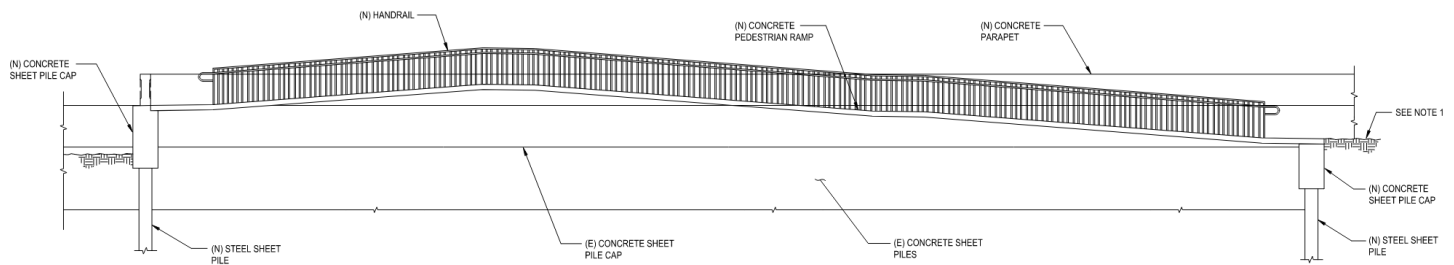

**Figure 4-10. Beach Access ADA Ramp**

#### 4.1.2.5 Beach Access Driveway at Thomas Ave

A 75-foot-long driveway is proposed at Thomas Avenue that would provide beach access for City equipment, shown in Figure 4-11 and Figure 4-12. The City anticipates the driveway would need to accommodate a 60-kip loader and provide a minimum 15-foot clear width. The driveway would be constructed parallel to the existing boardwalk at the north end of Segment B. The driveway would descend to competent material at approximately elevation 1.0 (NGVD29) based on recommendations provided in the 2022 Geotechnical Recommendations Report (TerraCosta). The City does not intend for this driveway to be used by the public, therefore it would not need to meet ADA ramp requirements. Because there is currently no shoreline protection provided, the driveway does not need to rise 2-feet before descending (as required for the pedestrian beach access locations).

The driveway would be supported by two new steel sheet pile walls with concrete caps, which would run parallel to the existing seawall. A structural concrete slab would span between the sheet piles. On the beach side, a parapet would be constructed to provide consistency with other segments of the seawall. On the boardwalk side, a new parapet would be constructed on top of the existing seawall as part of the Segment B work (Section 4.1.2.2). The new parapet on the existing seawall (Segment B) would not tie in directly with the driveway, meaning the driveway could be constructed before or after the Segment B work is completed.

The ROM cost to construct the beach access driveway is \$498,000; see Appendix C for additional information. The driveway can be constructed from the beach with minimal disruption to the boardwalk. The duration of construction is estimated to be one (1) month.

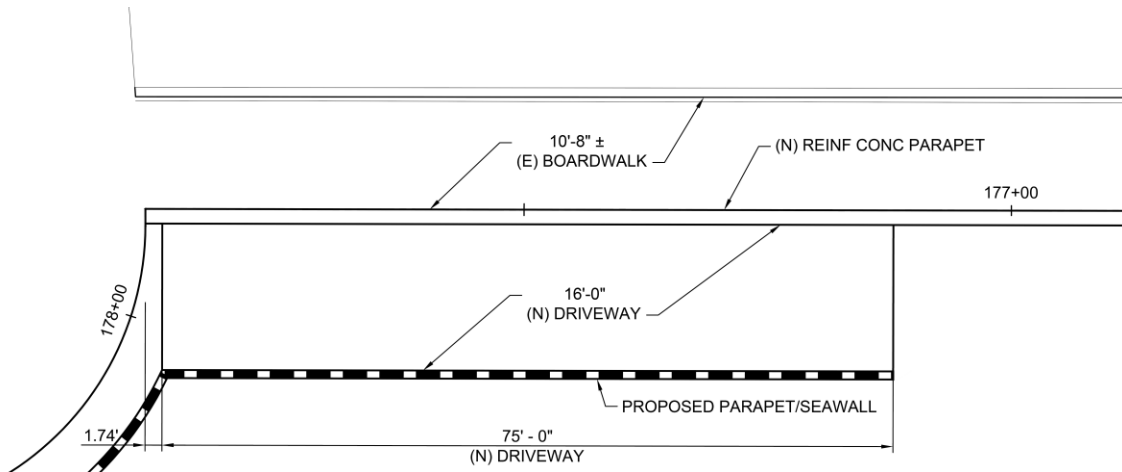

**Figure 4-11. Beach Access Driveway - Plan**

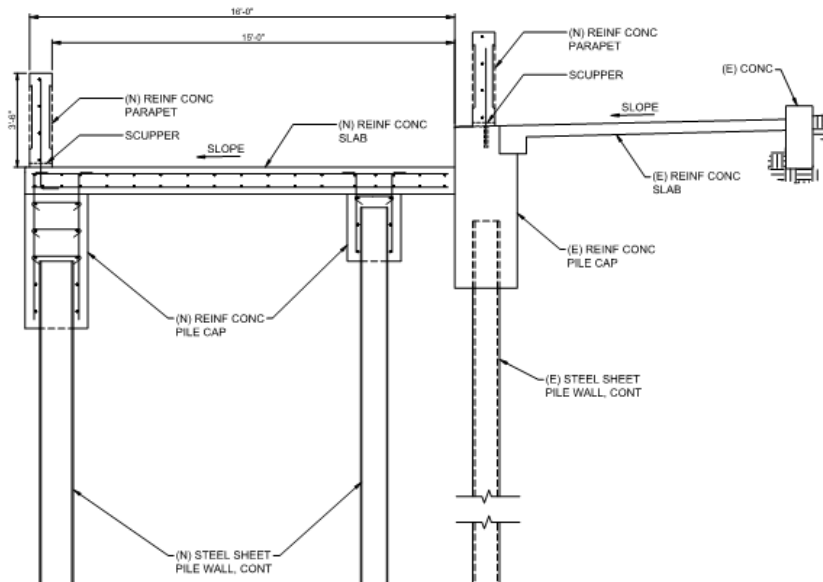

**Figure 4-12. Beach Access Driveway - Section**

## 4.2 Preliminary Opinion of Probable Construction Cost

For detailed cost estimates, refer to Appendix C – Opinion of Probable Construction Cost Estimate. Summaries of estimated costs are provided for Options 1 and 2. The cost estimates were developed using direct experience and knowledge based on similar items and projects, vendor quotes from recent projects for similar items, recent contractor quotes for similar items, and other historical cost information that is available. The following assumptions were made when developing the ROM cost estimates:

1. Costs shown are in 2022 dollars and do not include escalation.
2. Costs include a 25% contingency factor.
3. A SWPPP is included in cost.
4. General Conditions, Quality Control Costs, Contractor’s and Subcontractor’s Profit, Field Overhead, Home Office Overhead, and Mobilization and Demobilization are included in the unit prices.
5. No costs are included for design, construction management, or other direct costs.
6. Costs assume 8-hour per day, 5-day per week work schedule.
7. No allowance has been made for Contractor to move equipment to an offsite staging area overnight.
8. Costs assume Contractor will construct beach access points where street access to the boardwalk is available.

The ROM cost estimate for each item is summarized in Table 4-1. The costs are broken out such that the items of work can be completed incrementally based on City priority and available budget. Completing multiple items of work at the same time would reduce mobilization costs. The preliminary opinion of probable cost can be found in Appendix C.

**Table 4-1. ROM Cost Estimate Summary**

ITEM	ROM Cost	ROM Cost / Foot
Segment A: Option 1 - Parapet Replacement	\$5,126,000	\$585
Segment A: Option 1A - Void Repair	\$582,000	\$146
Segment A: Option 2 - Raised Boardwalk	\$18,350,000	\$2,095
Segment B: Parapet Replacement	\$676,000	\$663
Segment C: Option 1 - Seawall	\$1,396,000	\$3,723
Segment C: Option 2 - "Decorative" Wall	\$925,000	\$2,467
Beach Access Stairs (each)	\$134,000	-
Beach Access ADA Ramp (each)	\$718,000	-
Beach Access Driveway at Thomas Ave	\$498,000	-

### 4.3 Preliminary Project Schedule

The schedule to construct the project is difficult to determine given the possible variations involved in the concepts. Each concept consists of three segments (locational reaches), several options (e.g., 1, 1A, and 2), and choices of individual components (access stairs, ADA ramps and locations, void repair approaches, and a driveway). Due to the various choices still available to the City, the number of possible combinations of alternatives renders schedule preparation premature at this point. Rather than presenting multiple bar chart schedules to represent the number of combinations, this report presents durations for each scenario with the possible combinations considered. Once the City determines the exact combination of options to implement, then a schedule can be prepared to show the duration of each task.

Table 4-2 shows the options and their durations. Available construction windows will depend on permit acquisition for each project. The construction duration assumes 8-hour workdays, 5 days per week.

**Table 4-2. Durations for Each Project Component**

Segment	Component	Option	Duration (Months)
A	Replace Parapet	1	11.0
A	Void Repairs	1A	3.0
A	Raise Boardwalk	2	25.0
B	Replace Parapet	1	2.5
C	New Seawall	1	3.5
C	Decorative Wall	2	3.0
C	Beach Access Driveway	Not Applicable	1.0
Components Common to All Segments			
Not Applicable	Each Beach Access Stairway	Not Applicable	0.5
Not Applicable	Each ADA Pedestrian Beach Access Stairway	Not Applicable	1.0

## 5.0 Other Considerations as Appropriate

### 5.1 Feasibility Analysis of Constructability

Construction of the Mission Beach Seawall improvements is anticipated to be feasible. Construction means and methods will vary with respect to many imposing variables including the following: site location, project type, permit restrictions, construction window, construction budget, awarded contractor, and more. To limit the effect of such variables on construction, it is optimal to maintain the widest lens of possible construction methods while designing and permitting a project. The following section generally describes anticipated construction means and methods.

#### 5.1.1 Desired Construction Condition

The desired environmental condition is dry. The dry rainfall season of San Diego is typically the summer season, while the winter season is considered wetter. However, rainfall is typically limited during the winter season due to the desert climate. Ocean water may also affect the preferred dry condition of the Project. It is important that a wide beach is present throughout construction to buffer king tides and ocean waves from encroaching on the project and equipment. Mission Beach is known to typically maintain a wide beach due to sand retention effects of the north Mission Bay jetty. However, a strong El Niño winter storm season can cause erosion and coastal flooding, as has occurred in the past at the project site.

To facilitate efficient construction of the project in both time and budget, it is important to allow the contractor the greatest possible footprint for accessibility. This goal conflicts with the need to minimize impacts to public access. Construction during the visitor off-season (September to May) would help minimize public impact; however, the project is anticipated to take more than one year to construct. The active construction footprint, construction schedule, and construction phasing will need to be balanced to achieve optimal construction access and public access, simultaneously. One example to look to is the Cardiff Beach Living Shoreline Project in Encinitas, CA. Construction of this project took place during the visitor off-season. A maximum construction footprint of 1,000 ft (or one-third of the project length) was allowed at any one time. The contractor coordinated their work to complete distinct sections one after the other, yielding a moving construction footprint which completed the project from north to south. As a result, public access from the street to the beach was maintained along two-thirds of the beach at all times. Such compromises may also result from the permit application process, as these details become more defined.

#### 5.1.2 Construction Process

##### 5.1.2.1 Staging Areas and Access

Mobilization and demobilization of equipment and personnel for construction requires access points and staging areas on-site. Mobilization and demobilization of heavy construction equipment will be brought to the site by way of the regional highway (Interstate-5, Interstate-8, Pacific Coast Highway) and local street network. Local roads may include Grand Ave, Mission Blvd, Sea World Dr, and West Mission Beach Dr. The larger pieces of equipment will likely be transported to the site on trucks during the late evening to early morning (between 9 PM and 6 AM) hours to minimize potential traffic congestion. Additional equipment may be brought onto

the site, as the contractor deems necessary; however, this should be considered an isolated case and will not occur on a regular basis.

Landside construction requires direct access to the construction area. Daily traffic will consist of the personal vehicles owned by construction and construction management personnel, various inspectors, and other representatives from the various agencies and property owners involved with the project. The local roadways will require periodic maintenance and dust control that will be provided by the contractor. This will require coordination with private enterprises and residences. During discussions with such groups, topics including work hours, noise control, light control, and dust control will be touched upon to set public expectations.

Staging areas are required for the delivery, storage, and maintenance of equipment and materials. Staging areas will be selected to minimize impacts to the community and natural resources. Staging areas do not necessarily need to be on-site; however, providing the most efficient access routes for equipment and crew will reduce construction period and cost. The contractor will utilize access points where street access to the boardwalk is available. On-beach staging represents the most accessible site for the contractor to work from, however this is dependent on permit allowances and available beach width. Work is expected to primarily be performed from the beach side of the seawall.

The contractor will select construction equipment depending on the availability of equipment to the contractor at the time of construction and on regulatory permit requirements and restrictions. The following equipment list is anticipated to be utilized for construction of the project. Use of the equipment listed below was assumed within the preliminary construction cost estimate; however, the list is not exhaustive and instead represents the major pieces of equipment to anticipate:

- Forklift Truck
- 1 cy Excavator
- 4 cy Loader
- Crawler Crane
- Backhoe
- 40-ton Gooseneck Trailer
- Tilt Drum Concrete Mixer
- Personnel Trucks
- Portable Air Compressor

The following material list is anticipated to be utilized in construction of the project. Use of the materials listed below was assumed within the preliminary construction cost estimate; however, the list is not exhaustive and instead represents the major items to anticipate:

- Rebar
- Concrete
- Steel sheet piling
- Sand/Cement Grout
- Crushed Gravel
- Wood Formwork Material
- Straw Wattle

- Construction Fencing
- Contractor Temporary Buildings/Structures (office, storage, sanitary)
- Contractor Temporary Utilities

#### **5.1.2.2 Site Preparation**

The active construction footprint is anticipated to be approximately 1,000 ft long by 40 to 50 ft wide. Construction fencing will extend approximately 30 ft into the open beach area and 10 to 20 ft into the boardwalk area (i.e., half of the boardwalk) to keep the public out of the work area. Landside construction will require a minimum of 18 to 20 ft of clear area behind the immediate area of construction to facilitate the mobility of heavy equipment (e.g., excavator). It is assumed for this study that fencing will be placed in sections as work progresses, so boardwalk and beach access are maintained.

Temporary erosion control measures are left to the contractor's discretion; however, they will be required to comply with National Pollution Discharge Elimination System (NPDES) permit conditions and other local, State, and Federal program requirements. A condition of the contract documents for the contractor will be to comply with a storm water pollution prevention plan (SWPPP) that includes the identification of various best management practices (BMPs) for their construction activities. The contractor will then choose the BMPs most applicable to the current site conditions and submit their BMPs for approval prior to construction. Some examples of BMPs for erosion and sedimentation control might include:

- Preservation of existing vegetation
- Seeding and planting graded or cleared areas where construction activities have ceased
- Dust control to stabilize soil from wind erosion and construction activities
- Temporary storm drains or swales to divert off-site runoff
- Sandbags/straw bale barriers to control erosion from sheet flow
- Sediment traps/basins
- Water tank and connection for truck tire washdown area

If required, the demolition of trees, telephone poles, and other miscellaneous structures along with the organic materials excavated from clearing and grubbing the site will be hauled off-site for proper disposal at an approved landfill.

#### **5.1.2.3 Construction Methods**

During construction, anticipated limitations may include crew access and staging area availability due to a lack of public space and construction window limitations to reduce impacts to tourism.

The following outlines major construction activities and anticipated details:

- Mobilization/Demobilization
  - Mobilization will transport necessary construction equipment and materials to the site, such as loaders, excavators, crawler crane, forklift, etc.
  - Efficient staging and access of the site will be key to efficient construction, including overnight street and beach access.
  - Construction fencing will be required to separate construction from the public.

- SWPPP materials and BMPs will be installed in the construction footprint.
- Demolition
  - Considering the lack of access from the street and private residences located directly adjacent to the bulkhead wall, it is assumed demolition will occur from the beach side, with material stockpiled at truck load-out sites spaced evenly along the seawall. Laborers should sawcut wall along boardwalk in advance of demolition, and a second crew should cut rebar and clean up the concrete surface.
  - It is assumed concrete debris can be stockpiled onsite and hauled off at regular intervals. The existing concrete parapet wall is anticipated to be hauled to a concrete recycle facility after demolition.
- New Construction
  - Considering the lack of access from the street and private residences located directly adjacent to bulkhead wall, it is assumed all new construction would primarily occur from the beach side to the extent feasible. Concrete delivery must occur at locations with street access to the seawall, with concrete transported via slick lines from concrete pump to the new wall.

## 5.2 Risk Assessment

This section explores the variety of risks to help shed light on the potential future challenges that may be encountered during the Mission Bay Seawall improvements design process. By documenting the risks, and developing an understanding of common challenges, future pitfalls may be avoided or minimized to achieve the best possible outcome. The Mission Beach Seawall Improvements Feasibility Study is designed with the consideration of multiple potential risks, as summarized below.

A Risk Assessment Table containing the information from the risk assessment is provided in Appendix D.

The Risk Assessment Table was prepared based on three criteria: (1) probability of each risk occurring, (2) the potential impacts to cost, and (3) the potential impacts to time until project completion. Each risk was given a value of either very low, low, moderate, or high for each of the three risk assessment criteria. Additionally, a strategy and response action for each risk was determined.

### 5.2.1 Land Ownership

The Mission Beach Seawall Improvement Project is located along the Mission Beach Boardwalk and straddles the boundary between City of San Diego Right-of-Way and Mission Beach, which is designated as park, open space, and recreation. The project area is owned and maintained by the City of San Diego. As such, there are no known land ownership conflicts that may present risk to this project.

### 5.2.2 Utilities

A review of existing utilities was performed utilizing data from SanGIS, published by the City of San Diego Public Utilities Department and SANDAG. Available data includes water, sewer, and drain conveyance. As

depicted in Figure 5-1, the project boundary runs parallel to the Mission Beach neighborhood water and sewer utilities; however, no known conflicts exist.

The contractor will be required to take due precautionary measures to protect any existing utilities or structures located at the work site. It is the contractor’s responsibility to contact the owners of sewer, gas and electric, water, and sewer outfall utilities or structures prior to any excavation for verification and location of utilities and notification of commencement of work.

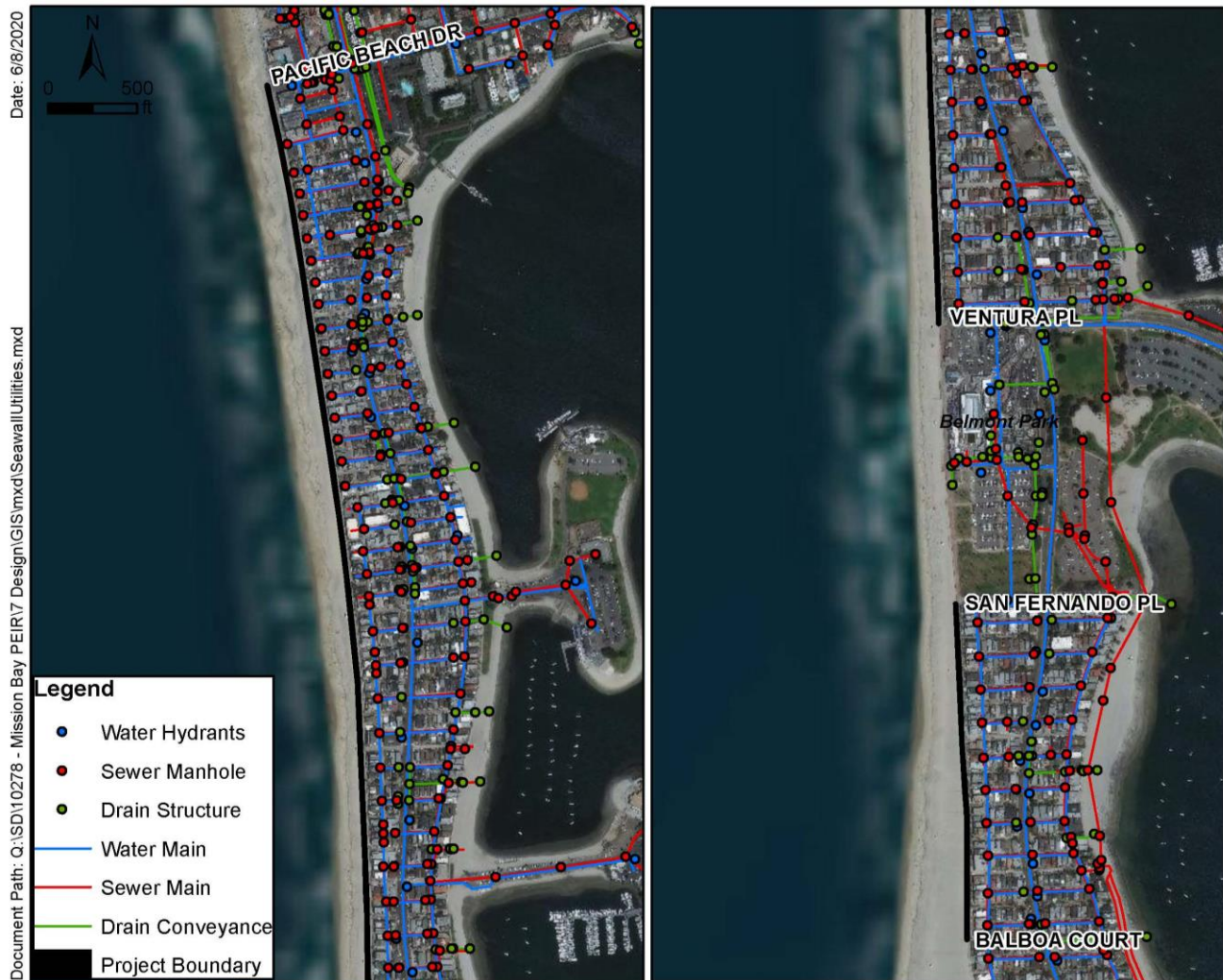

**Figure 5-1. Mission Beach Seawall Utilities**

### 5.2.3 Existing Geology Data

Geologic hazards which may impact the project area include potential seismic activity and existing soil data. Geological investigations (The Bodhi Group, 2018 and 2019), investigations by Southwest Geophysics (2012), Subsurface Surveys (1998), and a third-party review of the Mission Beach seawall (TerraCosta Consulting Group, 2019) provided a summary of such topics.

Mission Bay soils have been investigated through past geologic investigations by The Bodhi Group (2018). This study concluded the following:

- *There are no geologic hazards that cannot be avoided or addressed.*
- *There are no policies or recommendations of the Mission Bay Park Master Plan Update which will have a direct or indirect significant environmental effect with regard to geologic hazards.*
- *The proposed land uses are compatible with the known geologic hazards.*
- *There are no potential impacts related to geologic hazards from the implementation of the Mission Bay Park Improvement Projects that can't be avoided, reduced to an acceptable level of risk, or reduced below a level of significance through mandatory conformance with applicable regulatory requirements and the recommendations of this technical report.*
- *The impact of unstable soil can be reduced to less than significant levels by requiring geotechnical investigations on settlement sensitive projects (culverts, bridges, bulkheads and areas where substantial amounts of fill may be placed).*

The California Geological Survey described the geologic region of the project as composed of sedimentary units termed “old paralic deposits, undivided (late to middle Pleistocene)” and “marine beach deposits (late Holocene).” The material is generally beach sand derived from local sandstone and artificial fill likely derived from dredged material of Mission Bay (TerraCosta Consulting Group, 2019).

Most of the seawall is located along a geologic region described as having a low risk to geologic hazards. West of the seawall is described as “generally stable broad beach areas. The southern reach of the seawall from Coronado Court to Balboa Court, approximately 750 linear ft, is found to have a high potential for liquefaction. Liquefaction may be triggered by seismic activity and the resultant ground shaking (TerraCosta Consulting Group, 2019).

The project area “is not located within or crossed by a State-delineated Alquist-Priolo Earthquake Fault Zone. No known active faults underlie the Project area. However, the active Rose Canyon fault zone is located approximately 2.5 miles east of the project area. The maximum credible and probable earthquakes are magnitude 7.0 and 6.5, respectively. Other potential sources of ground shaking could be the Coronado Bank, La Nacion, San Diego Trough, San Clemente, Newport-Inglewood, Elsinore, and San Jacinto fault zones (TerraCosta Consulting Group, 2019).

Citing TerraCosta’s opinion: Most of the Mission Beach Seawall and Boardwalk was constructed more than 90 years ago. The seawall (and its sheet piles) was evaluated in 1998 by Geotechnics with limited subsurface excavation along the seawall. The City of San Diego may consider paying for another extensive study to evaluate the condition of the seawall and its sheet piles. However, it is TerraCosta’s opinion that a new study would likely have similar conclusions to the 2012 reports. The City should consider proceeding with the priority replacement repair phases that were provided by Harris & Associates (and others) in 2012 (TerraCosta Consulting Group, 2019).

Likewise, for the voids, it has been nearly 10 years since voids under the Mission Bay Boardwalk were mapped and documented by others. While the void information in this report is assumed to be accurate, there is potential that additional voids have emerged under the boardwalk since the issue was last reported.

Consequently, the City should perform additional subsurface investigations using surface penetrating radar, or other technology to update the plans and void information presented in this report.

### **5.2.4 Proximity to Neighbors**

The Mission Beach Seawall Improvement Project is located directly between the Mission Beach neighborhood and Mission Beach. To the west, the site is adjacent to beach sand and towel space located at the toe of the existing seawall. Just seaward of this is to state lands below the mean high tide line and navigable waters. To the east, the site is adjacent to a dense community of many parcel types, including but not limited to residential areas, private businesses supporting local and tourist uses, and public parks and recreational facilities. The boardwalk separates residences from the seawall by approximately 20-25 ft but is often occupied by active pedestrians.

Construction activities have the potential to impact neighbors in a multitude of ways, including, but not limited to, public access, noise impacts, and traffic impacts. Construction of the project will temporarily limit public access along the boardwalk and back-beach. However, long-term improvements to public access will result from project improvements. Noise impacts have the potential to disrupt visitor, commercial, and residential activity throughout Mission Beach. Commercial impacts could be felt by, for example, visitor supporting businesses, including restaurants and vacation rentals. Residential impacts could be felt by the Mission Beach community. Traffic impacts have the greatest potential to disrupt visitor use of Mission Beach and access to commercial and residential areas. Mobilization and demobilization of heavy construction equipment will be brought to the site by way of the regional highway (Interstate-5, Interstate-8, Pacific Coast Highway) and local street network. Construction activities may limit public access during certain periods of the day during construction.

Noise and traffic regulation may be necessary to restrict daily work hours and weekend work. Construction timing of the project may be scheduled to reduce impacts to visitor use. Peak visitor use spans approximately from Memorial Day (May) through Labor Day (September). The project is anticipated to occur during the off-season from September to May. Construction phasing may minimize public access impact. For example, the contractor can be directed to occupy no greater than 500 linear ft of the project at a time and work their way down the beach in the form a moving construction window, allowing the majority of the project area to be open to public access. The use of flaggers and traffic management may be necessary to protect public safety and access.

### **5.2.5 Environmental Windows**

Environmental constraints of endangered bird nesting seasons can impose environmental construction windows on certain projects. The nearest known protected nesting sites are within Mission Bay, as follows:

- Mariner’s Point – This least tern site is approximately 0.3 miles from the project site.
- North Fiesta Island – This least tern site is located approximately 2.1 miles from the project site.
- Stony Point – This least tern site is located approximately 1.3 miles from the project site.

Such distances to sensitive nesting sites are not anticipated to trigger construction timing restrictions.

Another potential sensitive species is the California grunion (*Leuresthes tenuis*), which have regularly been found on Mission Beach. The grunion is a member of the New World silversides family, Atheriniopsidae, along

with jacksmelt and topsmelt. Grunion leave the water at night to spawn on beaches during the spring and summer months. For four consecutive nights, beginning on the nights of the full and new moons, spawning occurs after high tides and continues for several hours. The eggs are kept moist by residual water in the sand. They hatch about 10 days later during the next high tide series, when they are inundated with sea water and agitated by rising surf. Spawning occurs from March through August, and occasionally in February and September. Peak spawning is late March to early June.

Currently, the wide beach width of Mission Beach (~150 ft) allows grunion spawning to occur sufficiently seaward of the project footprint. However, should major coastal erosion occur prior or during construction, it is possible that potential grunion spawning locations could be located immediately adjacent to or within the construction footprint. In such a case, the project may require grunion monitoring during the peak spawning season. Monitoring for grunion and implementation of impact minimization measures may be required when construction activities are scheduled to overlap or follow within two weeks of a grunion spawning event.

Should threatened and or endangered species be found on or near the sites, certain elements of the overall project may be necessarily phased or timed to mitigate impacts. For instance, breeding restrictions can limit construction from September 1<sup>st</sup> to February 15<sup>th</sup>. These potential project schedule impacts are an important part of the permits and engineering contract documents (plans, specifications, and estimates for contractor bidding). It is important to design the project with assurances to the resource agencies that the project will be implemented without incurring unanticipated incidental impacts. If this window can be opened further, construction can be done with slightly less urgency and accommodate contingency actions if they became necessary.

## 5.2.6 Water Quality Concerns

The Mission Beach Seawall Improvement Project is designed with consideration of the Mission Bay Park Master Plan water quality improvements initiative. The first Mission Bay Master Plan (San Diego, 1994) key recommendation is as follows:

*It is broadly recognized that the Park's economic and recreational future depends on the quality of the Bay's water. In response to fluctuating quality of the Bay waters, this Plan proposes a comprehensive set of measures involving state-of-the-art biological, mechanical, public education and recreation management programs. Biological measures include the establishment of salt-water marshes that can naturally filter pollutants as they enter the Bay through the creeks that drain the Bay's watershed...*

A past Water Quality Control Study (Tetra Tech, 1983) identified that the water quality problem largely stems from two issues:

- *A nearly continuous input of pollutants from various point and nonpoint sources within the increasingly urbanized drainage areas inland from the bay.*
- *Flushing and circulation conditions which are generally inadequate to transport pollutants out of the Bay. As a result, pollutants can build up to undesirable levels.*

The project is upland, and no direct interaction takes place with Mission Bay open waters. Construction activities will be required to comply with SWPPP standards to minimize any interaction that stormwater runoff

may have with Mission Bay waters. Any such interaction is anticipated to be short-term during storm events and during construction. The project is anticipated to have no negative long-term impacts to water quality.

### **5.2.7 Competing Interests**

City Charter Section 55.2 proposes that the Mission Bay Park Improvements project include efforts to restore wetlands, wildlife habitat, and other environmental assets, preserve beneficial uses of the Improvement Zone by maintaining navigable water and eliminating navigational hazards, restore embankments and erosion control features, and improve the conditions of the Improvement Zone for the benefit and enjoyment of residents and visitors.

The Mission Beach Seawall Improvement Project is focused on certain aspects of the larger City Charter Section 55.2 including improvement of erosion control features, improvement of sea level rise resilience, and improvement of residential and visitor support infrastructure. The project proposes to replace degrading reaches of the seawall, improve design to accommodate sea level rise and improve accessibility for pedestrians. The project is not anticipated to exacerbate issues regarding wetlands, wildlife habitat, or navigable water.

### **5.2.8 Sensitive Habitat**

The project area is located between a developed residential community and Mission Beach recreation area. As discussed in Section 5.2.5, no sensitive habitat is currently located within the project area. No impacts to sensitive habitat are anticipated as a result of the project.

### **5.2.9 Sea Level Rise**

As directed by the City, the restoration of shoreline project was developed with consideration of SLR risks. Two SLR projections (1.6 ft and 4.9 ft) were selected that represent major thresholds for the project. These thresholds represent the 5% probability scenario for the years 2050 and 2100 and are driven by coastal flooding that is expected to increase (progress inland) with a 100-year storm event in conjunction with SLR.

For the purposes of project design, SWLs under SLR scenarios are projected to pinpoint projected tidal elevations. Existing SWL elevations and future elevations based on the two chosen SLR scenarios are provided in Table 5-1.

**Table 5-1. Sea Level Rise Projected Still Water Levels**

<b>Datum</b>	<b>Abbreviation</b>	<b>Existing SWL (ft, NGVD29)</b>	<b>1.6 ft SLR SWL (ft NGVD29)</b>	<b>4.9 ft SLR SWL (ft NGVD29)</b>
Highest Observed Tide (11/25/2015)	HOT	5.49	7.09	10.39
Mean Higher-High Water	MHHW	3.00	4.6	7.9
Mean High Water	MHW	2.28	3.88	7.18
Mean Sea Level	MSL	0.41	2.01	5.31
National Geodetic Vertical Datum of 1929	NGVD29	0.00	1.6	4.9
Mean Low Water	MLW	-1.42	0.18	3.48
North American Vertical Datum of 1988	NAVD88	-2.13	-0.53	2.77
Mean Lower-Low Water	MLLW	-2.32	-0.72	2.58
Lowest Observed Tide (12/17/1937)	LOT	-5.19	-3.59	-0.29

### 5.2.9.1 Flooding

Vulnerability of the existing wall to flooding was based on results from the Coastal Storm Modeling System (CoSMoS), an ensemble of numerical models developed by the United States Geological Survey (USGS, 2018), which provides estimates of present and future coastal hazards along various reaches of the California Coast. CoSMoS coastal flooding projections indicate high exposure to flooding in Mission Beach for a SLR of 4.9 ft. The timeframes for SLR of 4.9 feet is estimated to occur between years 2080 to 2090 for a medium-high risk scenario according to 2018 Guidance, and between 2100 and 2110 under the 2024 Guidance under the Intermediate High SLR scenario. See Figure 5-2 for a plan view representation of tidal inundation and Figure 5-3 for a cross-section representation. See Figure 5-4 for a plan view representation of storm flooding and Figure 5-5 for a cross-section representation.

The project is anticipated to be encroached upon by tidal and storm flooding under 1.6 ft of SLR. Under the 4.9-ft SLR scenario, water levels corresponding to a storm with a recurrence period of 100 years, result in flooding both seaward (i.e., flooding from the ocean) and landward (i.e., flooding from Mission Bay) of the wall. Since the upland development backing the wall becomes exposed to flooding from the Bay, the purpose of a seawall is defeated with 4.9 ft of SLR. It is assumed that other adaptation strategies will be implemented before this condition is reached; therefore, development of a replacement wall concept was targeted to better accommodate, but not to be able to completely protection against SLR of 1.6 ft.

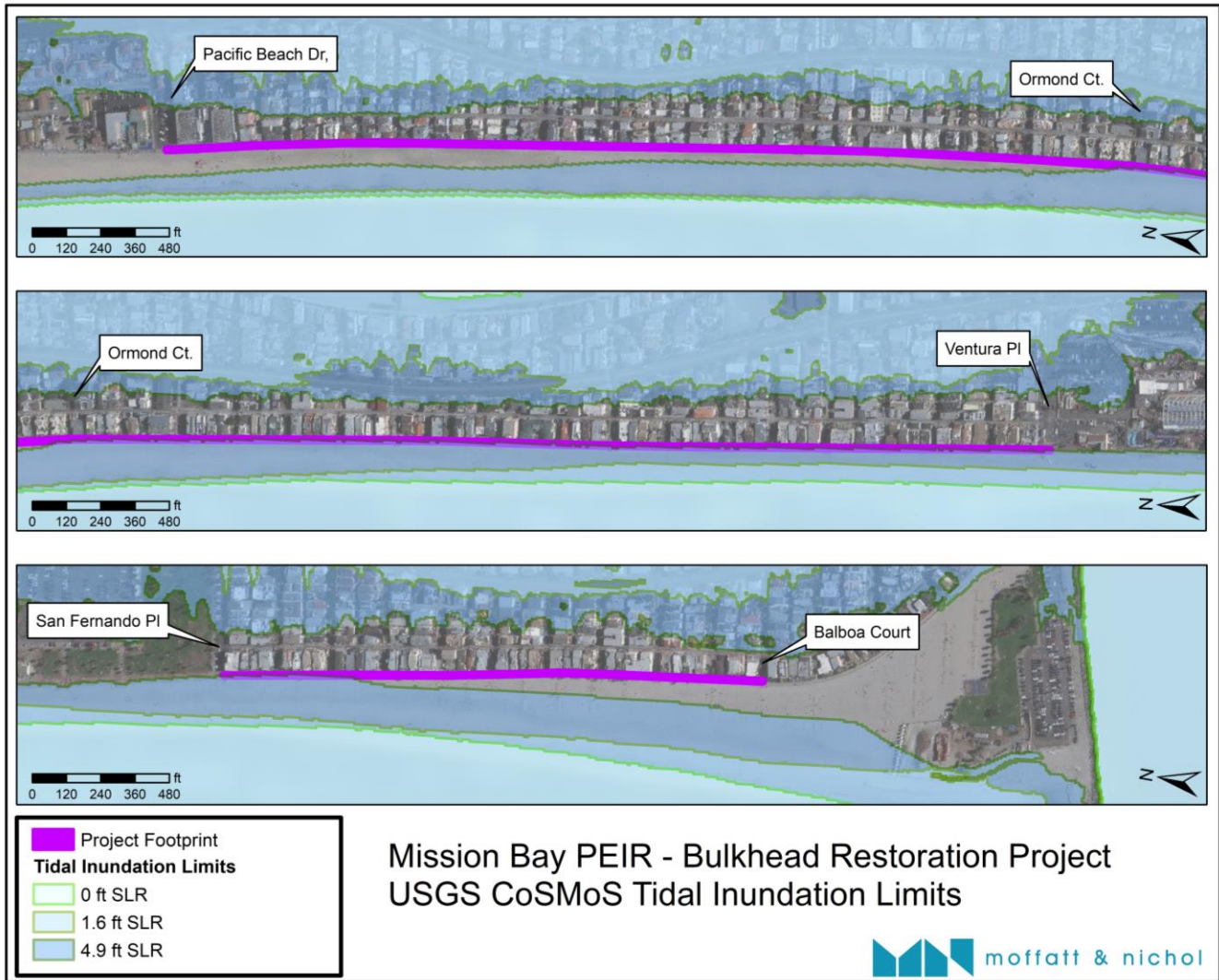

**Figure 5-2. Tidal Inundation Limits Along the Mission Bay Seawall Improvement Sections**

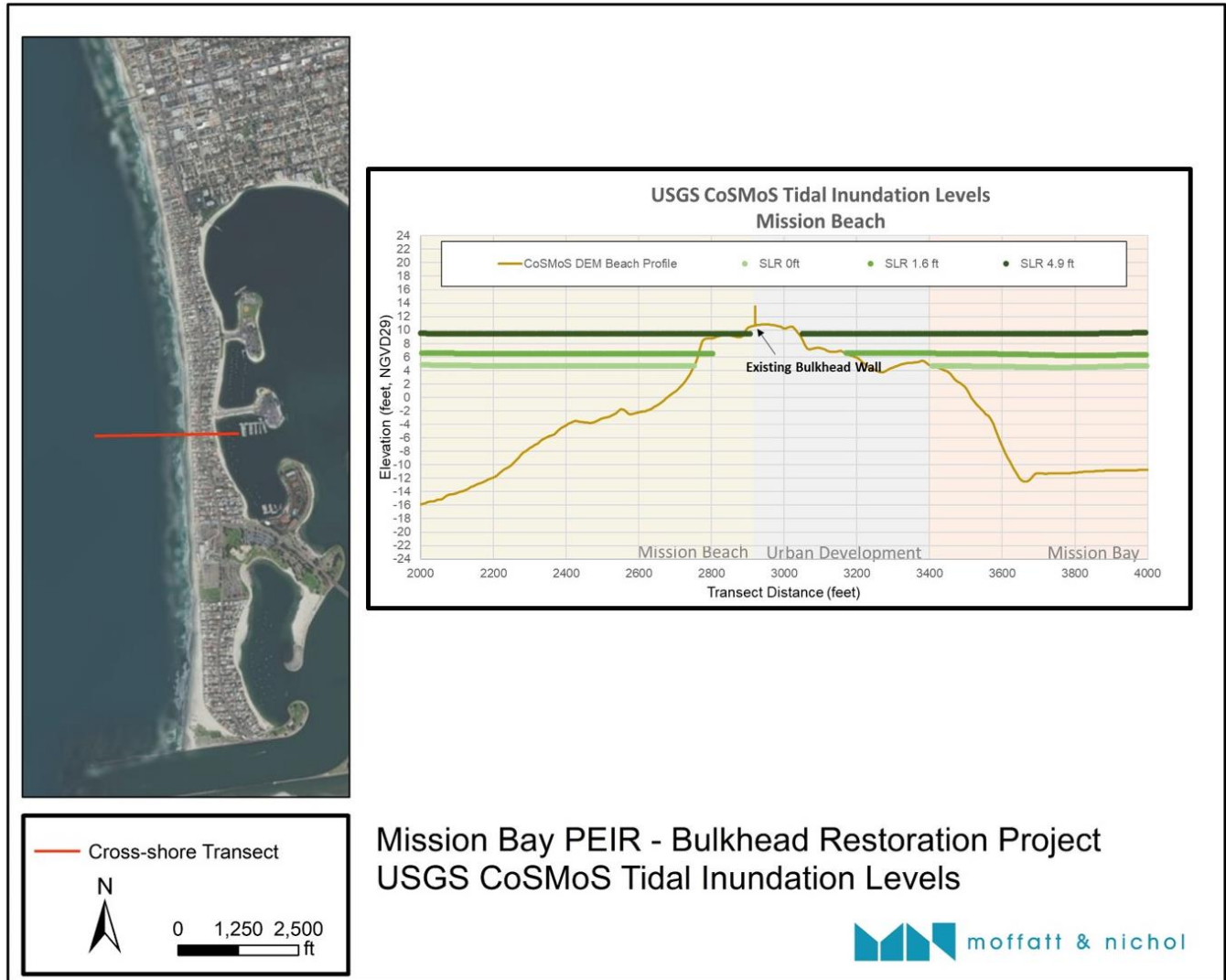

**Figure 5-3. Tidal Inundation Levels at Mission Beach**

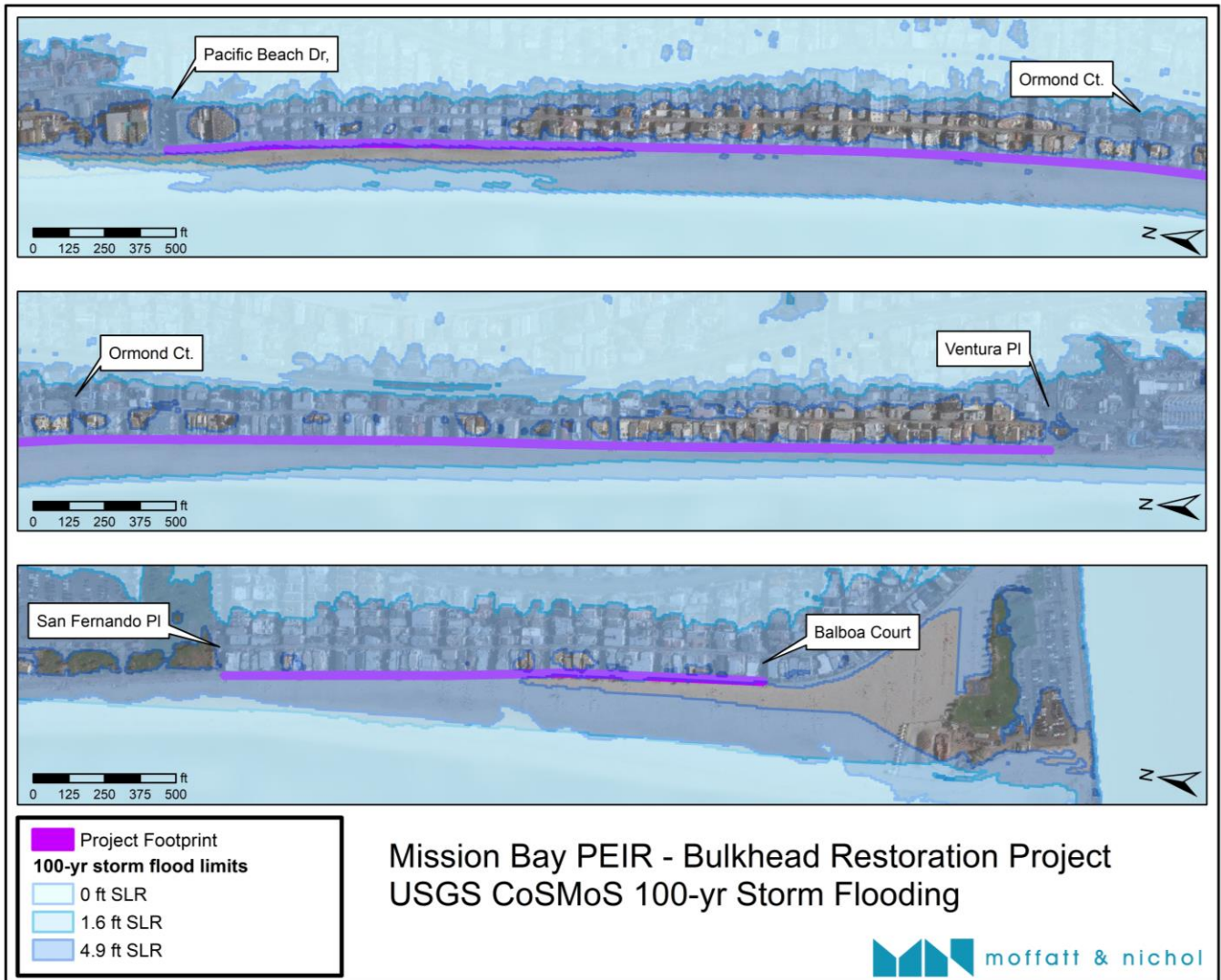

**Figure 5-4. Storm Flood Limits Along the Mission Bay Seawall Improvement Sections**

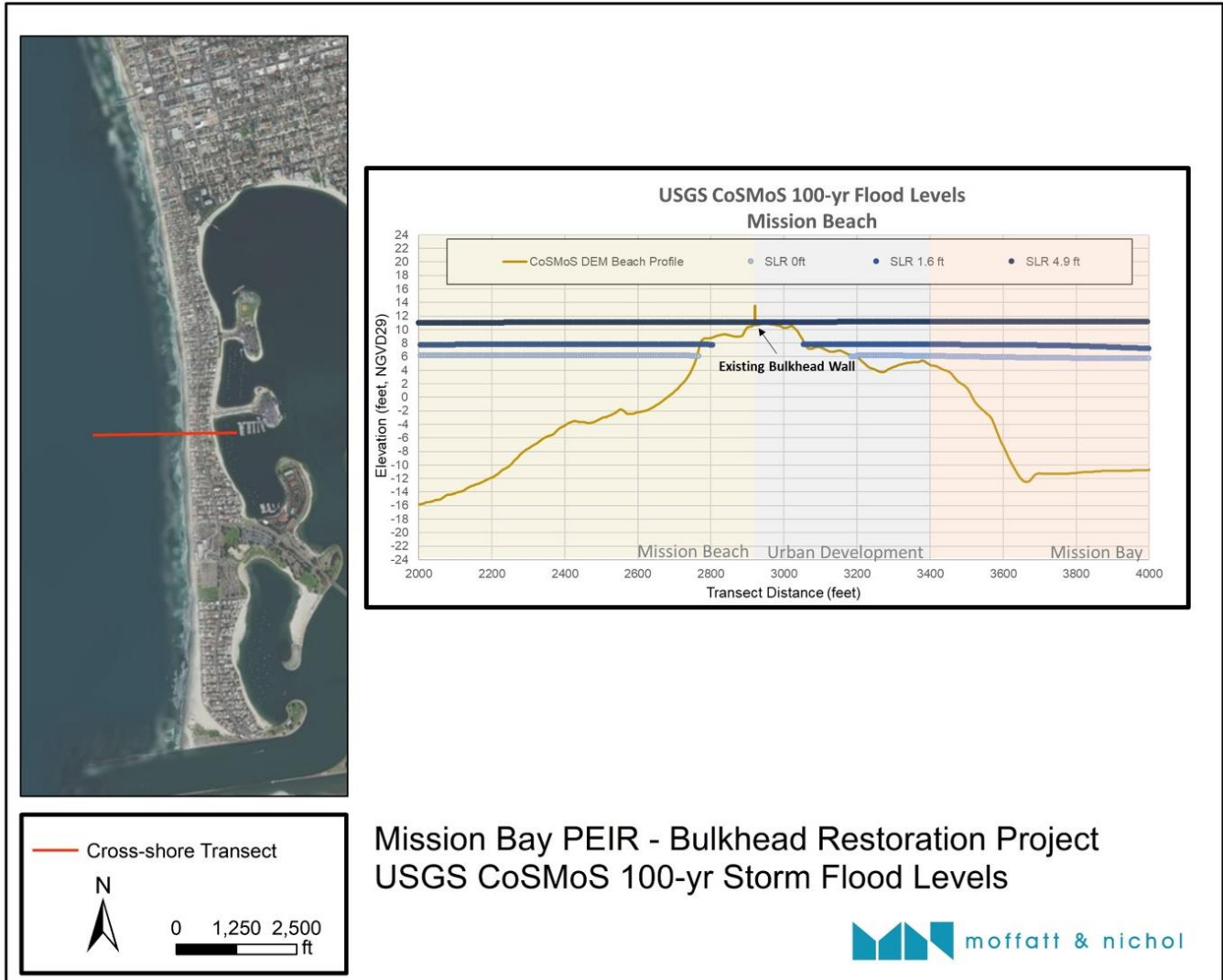

**Figure 5-5. Flood Inundation Limits at Mission Beach**

**5.2.9.2 Wave Overtopping**

Functionality of the existing and proposed replacement wall was evaluated in terms of wave overtopping discharges. Wave overtopping is a function of the wall crest elevation, the incident wave height, and the water depth in front of the wall.

Overtopping rates are typically quantified in a volumetric rate per length of structure (e.g., cubic feet per second per foot of wall [cfs/ft]). Overtopping rates of 3.0 cfs/ft during extreme storm events generally provide an acceptable balance between structural safety, economics, and aesthetics. Wave overtopping rates for the second design concept (Segment A, Option 2), described below, under the design condition (i.e., the 100-yr storm and a SLR of 1.6 ft) are below the 3.0 cfs/ft threshold. Although overtopping discharges for the first design concept (Segment A, Option 1), replacement-in-kind, described previously (see section 2.4.3), are higher than the established threshold functionality, and resiliency to SLR is enhanced compared to the existing seawall. Table 5-2 provides a summary of the overtopping analysis results.

**Table 5-2. Wave Overtopping Discharge for Proposed Seawall Improvements (Segment A, Option 2)**

SLR	100-yr Storm Flood Levels (ft, NGVD29)	Significant Wave Height (ft)	Overtopping Discharge Q (cfs/ft)
0 ft	5.9	5.5	0.5
1.6 ft	7.6	7.6	2.4

### 5.3 Project Conflict Coordination and Evaluation

The Mission Beach Seawall Improvement Project evaluates the potential conflict with Mission Bay Park Improvement Program projects and nearby Capital Improvement Plan (CIP) projects.

#### 5.3.1 Mission Bay Park Improvement Program Projects

Four projects under the Mission Bay Park Improvement Program are accessed through the Mission Beach community. The projects are under the umbrella of the Restoration of Shoreline, and include West Sail Bay, Ventura Cove Park, Bahia Point, and Bonita Cove shoreline restoration projects. As with the Mission Beach Seawall Improvement Project, construction timing of the shoreline restoration projects will likely be scheduled to reduce impacts to visitor use. Peak visitor use spans approximately from Memorial Day (May) through Labor Day (September). Noise regulation may be necessary to restrict daily work hours and weekend work. Should material import come by truck, truck routes must be negotiated to minimize impacts to adjacent projects as well as public use.

#### 5.3.2 Capital Improvement Plan Projects

Adjacent CIP projects are depicted in Figure 5-6. Water main, sewer main, streetlight, and related underground utilities are proposed for rehabilitation and replacement. It is unlikely that these projects will conflict as the utilities to be in question do not intersect with the Mission Beach seawall. However, traffic and noise conditions can be exacerbated by coinciding construction projects; therefore, coordination may improve the success of the two projects.

Potential conflict exists between the Mission Beach Seawall Improvement Project and the South Mission Beach Storm Drain and Green Infrastructure Project. The South Mission Beach Storm Drain and Green infrastructure Project will replace/relocate five storm drains that outfall into Mariner’s Basin and Bonita Cove and will construct one new outfall in Mariner’s Basin. These systems will also install additional storm drains within Mission Boulevard between San Fernando Place and North Jetty Road to capture runoff in new inlets versus numerous existing weep sumps. Additionally, two storm drains that outfall into the Mission Bay Jetty will also be replaced in place. The project also includes the replacement and addition of low flow diversion structures to nearby sewer mains for each of the outfalls, construction of nine water quality basins, street resurfacing, and grading of the beach at outfall locations, which will be designed to allow for eelgrass mitigation. One of the primary locations being considered for the eelgrass mitigation is at the storm drain outfall at San Fernando Place. Although the two projects are on opposite sides of the Mission Beach peninsula, the small size of the community and limited access roads may create noise and traffic sensitivity issues. Noise

regulation may be necessary to restrict daily work hours and weekend work. Should material import come by truck, truck routes must be negotiated to minimize impacts to adjacent projects as well as public use.

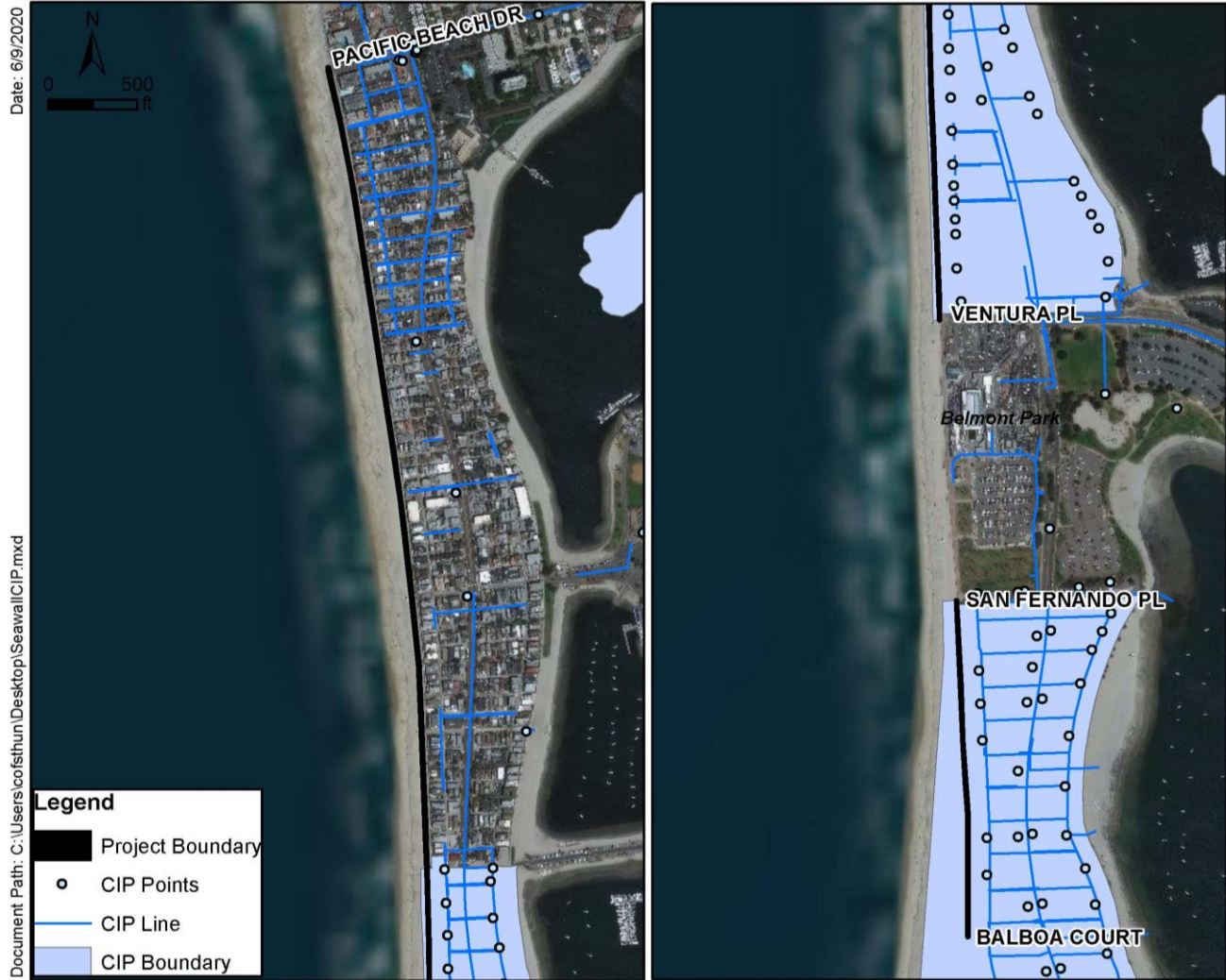

**Figure 5-6. Adjacent CIP Projects**

## 5.4 Environmental Considerations and Permits

As a part of the Mission Bay Park Improvement Plan PEIR, the City is seeking to streamline state and federal resource agency approval for all future projects, including the Mission Beach Seawall Improvements. This work includes but is not limited to preparation and submission of applications for regulatory permits to the U.S. Army Corps of Engineers (USACE), pursuant to Section 404 of the federal Clean Water Act (CWA) and Section 10 of the Rivers and Harbors Act; California Regional Water Quality Control Board (RWQCB), pursuant Section 401 of the federal CWA; and California Department of Fish and Wildlife (CDFW), pursuant to the California Fish and Game Code (Section 1600). Additionally, permitting support and strategy for the CCC pursuant to the California Coastal Act and Coastal Zone Management Act is in progress.

- Pursuit of USACE Section 404 CWA programmatic permit is anticipated to be applied for as a Regional General Permit (RGP) to authorize the implementation of multiple projects within Mission Bay. An RGP can authorize a category or categories of activities, such as the Mission Bay Park Improvements, in a specific geographical region for activities that are similar in nature and cause only minimal individual and cumulative environmental impacts.
- In pursuit of a U.S. Fish and Wildlife Service (USFW) Programmatic Biological Opinion, a Biological Assessment (BA), which is a modified version of a Biological Technical Report (BTR), is required in accordance with Section 7 of the Endangered Species Act (ESA). The BA is focused on project impacts on and restoration benefits for the California least tern, western snowy plover, and other federally listed species, including marine species, which have the potential to occur within the project area. It is not anticipated that protected avian species will be identified within the project area.
- In pursuit of a RWQCB programmatic 401 Water Quality Certification, an application will be required as well as RWQCB-issued General Waste Discharge Requirements (WDRs) for authorization of Mission Bay Park Improvements.
- A State Tideland Trust agreement is not anticipated to be required from the State Lands Commission as the Project is located upland of State Lands.

Environmental permits that may be required to construct the Project are listed in, but not limited to, Table 5-3.

The project is anticipated to be feasible for construction; however, resource agency-imposed restrictions play a strong role in construction costs and duration. During discussions with resource agencies, permit restrictions will be negotiated, including but not limited to the following:

- Hours of Operations
- Noise Control (See Section 5.4.1)
- Light Control
- Dust Control
- Fueling
- Site Access
- Storage and Staging
- Impacts to Habitat and Sensitive Species

Regarding the above topics, the City should strive for the following in order to maintain flexibility of construction methods:

- 6-day work weeks
- Hours of operation from 7AM to 6PM with occasional night work, as necessary
- Wide environmental window
- Land-based site access, including on-beach
- Fueling and equipment maintenance permitted on-site
- Flexible construction access and staging areas

- Multiple construction access and staging areas allow various approaches to be conceived by contractors to increase competition during bidding.
- Staging areas within or close in proximity to the construction area reduces construction duration and cost.

**Table 5-3. Environmental Permit Considerations**

Agency	Permit
<b>Federal</b>	
U.S. Army Corps of Engineers (USACE)	<ul style="list-style-type: none"> <li>• ESA, 16 USC Sections 1531-1544 Section 7 Consultation with the federal lead agency (i.e., USACE)</li> <li>• Programmatic Biological Opinion</li> </ul>
<b>State</b>	
California Coastal Commission (CCC)	<ul style="list-style-type: none"> <li>• Coastal Development Permit</li> <li>• Consistency Certification, Section 30600(a) of the California Coastal Act, or Waiver of Federal Consistency Provisions</li> </ul>
Regional Water Quality Control Board (RWQCB)	<ul style="list-style-type: none"> <li>• Water Quality Certification under Section 401 of the CWA</li> </ul>
<b>Regional/Local</b>	
City of San Diego (City)	<ul style="list-style-type: none"> <li>• Grading Permit</li> <li>• Right-of-Way Permit</li> <li>• Traffic Control Permit</li> <li>• Site Development Permit</li> </ul>

### 5.4.1 Noise Control

Federal and state noise regulations are enforced for the protection of public health and safety to prevent the disruption of certain human activities and address the effects of noise on the environment. The EPA established the Noise Control Act of 1972; regulatory responsibilities have since been transferred to state and local governments. Noise control measures often included the definition of construction windows, maximum noise level limits (measured in decibels [dBA]), noise level durations, regulation of vibration, consideration of nearby land uses, and more.

Construction noise can be a major, typically short-term, source of noise. Construction equipment that are likely to be used to construct the project produce a range of noise levels, including but not limited to those presented in Table 5-4. Ambient noise values have been recorded as part of the De Anza Cove Environmental Analysis, located approximately 2 miles east of the Project site, and may provide a good approximation for the project. Ambient noise has a mean measured in the range of 42.9 to 77.5 dBA within Mission Bay in the De Anza Cove/Campland area. CEQA impact analysis for noise impacts will be required prior to the construction of the proposed project to determine potential conflict with San Diego Municipal Code (SDMC) and relevant standards, likely including but not limited to the following:

1. Result in or create a significant increase in the existing ambient noise levels;
2. Result in an exposure of people to current or future transportation noise levels which exceed guidelines established in the Noise Element of the General Plan;

3. Result in land uses which are not compatible with aircraft noise levels;
4. Result in the exposure of people to noise levels which exceed property line limits established in the Noise Abatement and Control Ordinance of the SDMC; or
5. Result in the exposure of people to significant temporary construction noise.

**Table 5-4. Typical Construction Equipment Noise Levels**

Equipment Type	Maximum of Noise Level at 50 ft (dBA)
Backhoe	80
Compactor (ground)	80
Compressor (air)	80
Dump Truck	84
Excavator	85
Flat Bed Truck	84
Generator (25 KVA or less)	70
Generator (more than 25 KVA)	82
Pumps	77
Tractor	84

## 5.5 City Professional Standards and Mission Bay Masterplan Consistency

Concept development, design, and permitting of the project must comply with City standards and the Mission Bay Park Masterplan (2002). An inventory of relevant standards, potential conflicts, and potential resolutions to such conflicts, is provided in Table 5-5.

**Table 5-5. Inventory of Relevant Standards**

Source	Standards and Recommendations	Compliance / Potential Conflict	Implementation / Solution
Mission Bay Park Master Plan Mission Bay Park Master Plan (Continued)	The turf and beach areas along the Park's shorelines support the most intensive public recreational activity in Mission Bay. These areas draw users from throughout the San Diego region. With the County's population on the rise, the capacity of the park to accommodate this activity must be commensurately increased.	The project is developed with the general goal of improving or maintaining public recreational activity.	<b>Improvements</b> - Infrastructure Improvements - Shoreline Stabilization
	The rise of environmental awareness in recent decades has been paralleled by an increase in the desire for more natural recreation venues. The telephone survey conducted as part of the Master Plan Update revealed that a majority of San Diego residents would like to experience parts of Mission Bay in a more natural condition.	No changes to the natural condition of Mission Beach is proposed.	No conflict.
	In response to an extraordinary level of public demand for preservation and enhancement of natural resources, this Plan includes a number of proposals aimed at improving the Park's wildlife habitats.	No changes to the natural condition of Mission Beach is proposed.	No conflict.
2018 City CADD Standards	The City uses the Bentley MicroStation as its basic CADD graphics engine, for engineering design and drawing production. If approved by the City, Design Consultants may use other industry standard CADD systems, such as AutoCAD, to produce hard copy or PDF files that can be transmitted appropriately to the Project Managers as submittals. However, for compatibility reasons, all electronic CADD file submittals must be created in MicroStation or an approved CADD system using City-specified seed files that will be uploaded into the City's CADD file management system and shall conform to the requirements set forth in these standards ( <a href="https://www.sandiego.gov/publicworks/edocref/drawings">https://www.sandiego.gov/publicworks/edocref/drawings</a> ).	M&N may submit final electronic CADD files in MicroStation.	No conflict.
City Stormwater Guidelines	Project plans to comply with The City of San Diego Storm Water Standards and the MS4 Permit.	M&N project plans to comply with City standards.	No conflict.

## 5.6 ADA and Title 24

### 5.6.1 Americans with Disabilities Act 1990

The Americans with Disabilities Act (ADA) of 1990 is a civil rights law prohibiting discrimination against individuals with disabilities. With respect to the Project, ADA requirements pertain to the Mission Beach boardwalk and beach access paths. No design changes are proposed to the existing boardwalk or beach access paths. The project proposes to replace-in-kind the boardwalk.

To ensure compliance with City ADA requirements, the following City recommendations for design of pedestrian access ways are to be incorporated:

- Walks and Sidewalks at Accessible Routes
  - In order to accommodate construction tolerances and variations in field conditions, the cross slope at paved walking surfaces that are part of an accessible route should have a maximum cross slope of 1.5% (1:66) gradient. This includes stabilized decomposed granite paved walking surfaces and sidewalks along the public right-of-way.
  - In order to accommodate construction tolerances and variations in field conditions, the running slope at paved walking surfaces that are part of an accessible route should not exceed 4.5% (1:22) gradient.
- Pedestrian Ramp
  - The least possible slope should be used for a pedestrian ramp without exceeding the maximum running slope of 6.67% (1:15) gradient.
  - If site conditions restrict the use of 6.67% (1:15) gradient or less, then the running slope of the pedestrian ramp(s) should not exceed 8.33% (1:12) gradient.
- Curb Ramps
  - Newly constructed or altered streets, roads, and highways must contain curb ramps or other sloped areas at any intersection having curbs or other barriers to entry from a street level pedestrian walkway. 28 Code of Federal Regulations § 35.151(e)(1).
  - Newly constructed or altered street level pedestrian walkways must contain curb ramps or other sloped areas at intersections to streets, roads, or highways. 28 Code of Federal Regulations §35.151(e)(2).
  - A curb ramp shall be provided wherever an accessible route crosses a curb – ADAAG 4.7.1.
  - Curb ramps shall be constructed at each corner of street intersections and where a pedestrian way crosses a curb. The preferred and recommended location for curb ramps is in the center of the crosswalk of each street corner. Where it is necessary to locate a curb ramp in the center of the curb return and the street surfaces are marked to identify pedestrian crosswalks, the lower end of the curb ramp shall terminate within such crosswalk areas – 2001 CBC 1127B.5.1.
  - A curb ramp shall have a detectable warning complying with ADAAG 4.29.2. ADAAG 4.7.7.
  - Detectable warnings shall consist of raised truncated domes. ADAAG 4.29.2.

- A curb ramp shall have a detectable warning . . . when the ramp slope is less than 1 unit vertical to 15 units horizontal. Detectable warnings shall consist of raised truncated domes. 2001 CBC 1127B.5.8.

### **5.6.2 Title 24**

Title 24 is a California Building Standards Code establishing requirements for “energy conservation, green design, construction and maintenance, fire and life safety, and accessibility” of a building’s “structural, mechanical, electrical, and plumbing systems.” No buildings are proposed as a part of the project; therefore, Title 24 requirements are not applicable.

## 6.0 Bibliography

- Atkins (2021). California State Legislation, SB 1, Sea Level Rise Mitigation and Adaptation Act of 2021. [Legislation].
- The Bodhi Group, 2018. Draft – Geotechnical and Geologic Hazard Evaluation – Mission Bay Park Improvements Projects – San Diego, California. Prepared for Dudek. December 2018.
- The Bodhi Group, 2019. Cone Penetration Test Study – Mission Bay Park Improvements Projects – San Diego, California. Prepared for Dudek. May 2019.
- CCC (California Coastal Commission), 2018. *California Coastal Commission Sea Level Rise Policy Guidance: Interpretive Guidelines for Addressing Sea Level Rise in Local Coastal Programs and Coastal Development Permits*. California Coastal Commission, San Francisco, CA.
- City of San Diego, 2019. Sea Level Rise Vulnerability Assessment - Draft. Prepared by ICF. December 2019.
- City of San Diego, August 2, 1994 (Amended July 9, 2002). Mission Bay Park – Master Plan Update.
- City of San Diego, May 1990. Final – Mission Bay Park – Natural Resource Management Plan. Prepared for Park and Recreation Department by the Development and Environmental Planning, Planning Department, City of San Diego.
- Daniel McNaughton and Associates, 1998. Seawall Integrity Study for Mission Beach Boardwalk. May 4, 1998.
- Dudek, 2021. Mission Beach Seawall and Boardwalk. Technical Memo from Architectural Historian. September 1, 2021.
- Geotechnics Incorporated, 1998. Report of Observations and Conclusions Engineering Consultation Seawall Integrity Study for Mission Beach Boardwalk. San Diego California: DN. 8-0317R.
- Harris & Associates, 2012. Mission Beach Seawall and Boardwalk Integrity Study – Mission Beach Boardwalk, San Diego, CA. April 20, 2012.
- IPCC, 2013: *Climate Change 2013: The Physical Science Basis. Contribution of Working Group I to the Fifth Assessment Report of the Intergovernmental Panel on Climate Change* [Stocker, T.F., D. Qin, G.-K. Plattner, M. Tignor, S.K. Allen, J. Boschung, A. Nauels, Y. Xia, V. Bex and P.M. Midgley (eds.)]. Cambridge University Press, Cambridge, United Kingdom and New York, NY, USA, 1535 pp.
- IPCC, 2023: Annex I: Glossary [Reisinger, A., D. Cammarano, A. Fischlin, J.S. Fuglestedt, G. Hansen, Y. Jung, C. Ludden, V. Masson-Delmotte, R. Matthews, J.B.K Mintenbeck, D.J. Orendain, A. Pirani, E. Poloczanska, and J. Romero (eds.)]. In: *Climate Change 2023: Synthesis Report. Contribution of Working Groups I, II and III to the Sixth Assessment Report of the Intergovernmental Panel on Climate Change* [Core Writing Team, H. Lee and J. Romero (eds.)]. IPCC, Geneva, Switzerland, pp. 119-130, doi: 10.59327/IPCC/AR6-9789291691647.002.
- Kopp, R.E., Horton, R.M., Little, C.M., Mitrovica, J.X., Oppenheimer, M., Rasmussen, D.J., Strauss, B.H. and Tebaldi, C., 2014. Probabilistic 21st and 22nd century sea-level projections at a global network of tide-gauge sites. *Earth's future*, 2(8), pp.383-406.

- Merkel & Associates, Inc, 2013. Mission Bay Park, 2013 Bathymetry and Eelgrass Inventory. Prepared for City of San Diego, Public Works, E&CP, AEP Division. Prepared by Merkel & Associates, Inc.
- Moffatt and Nichol, 2019, Mission Bay PEIR Hydrology Study.
- NOAA, 2019. NOAA Tides & Currents. [www.tidesandcurrents.noaa.gov/](http://www.tidesandcurrents.noaa.gov/).
- Ocean Protection Council (OPC), 2017. Rising Seas in California – An Update on Sea Level Rise Science. April 2017.
- Ocean Protection Council (OPC), 2018. State of California Sea-Level Rise Guidance, 2018 Update.
- Simon Wong Engineering, 2012. Mission Beach Boardwalk. Mission Beach Seawall and Boardwalk Integrity Study.
- Southwest Geophysics, 2012. Geophysical Evaluation, Mission Beach Boardwalk. March 16, 2012.
- Subsurface Surveys, 1998. Search for Voids Beneath Mission Beach B'walk. April 11, 1998.
- Sweet, W. V., R. E. Kopp, C. P. Weaver, J. Obeysekera, R. Horton, E. R. Thieler, and C. Zervas, 2017. *Global and regional sea level rise scenarios for the United States*, Technical Report NOS CO-OPS 083, National Oceanic and Atmospheric Administration. USACE (U.S. Army Corps of Engineers). 1982. *Hydrologic Analysis of Ungauged Watersheds Using HEC-1*. Training Document No. 15. HEC TD-15. U.S. Army Corps of Engineers, Hydrologic Engineering Center, Davis, CA.
- TerraCosta Consulting Group, Inc., 2019. Third-Party Review, Mission Beach Seawall and Boardwalk, San Diego, California. Prepared for The Bodhi Group. April 8, 2019.
- TerraCosta Consulting Group, Inc., 2022. Mission Beach Seawall Extension and Existing Void Infilling Geotechnical Recommendations, San Diego, California. Prepared for The Bodhi Group. October 11, 2022.
- Testing Engineers – San Diego, 1998. Preliminary Test Information, Mission Beach Seawall. April 28, 1998.
- Tetra Tech, 1983. *Water Quality Control Studies – Mission Bay Park*. Prepared for City of San Diego. March 1983.
- USGS, 2018. Coastal Storm Modeling System (CoSMoS) for Southern California, v3.0, Phase 2.

## **A. FEMA Preliminary Flood Maps**



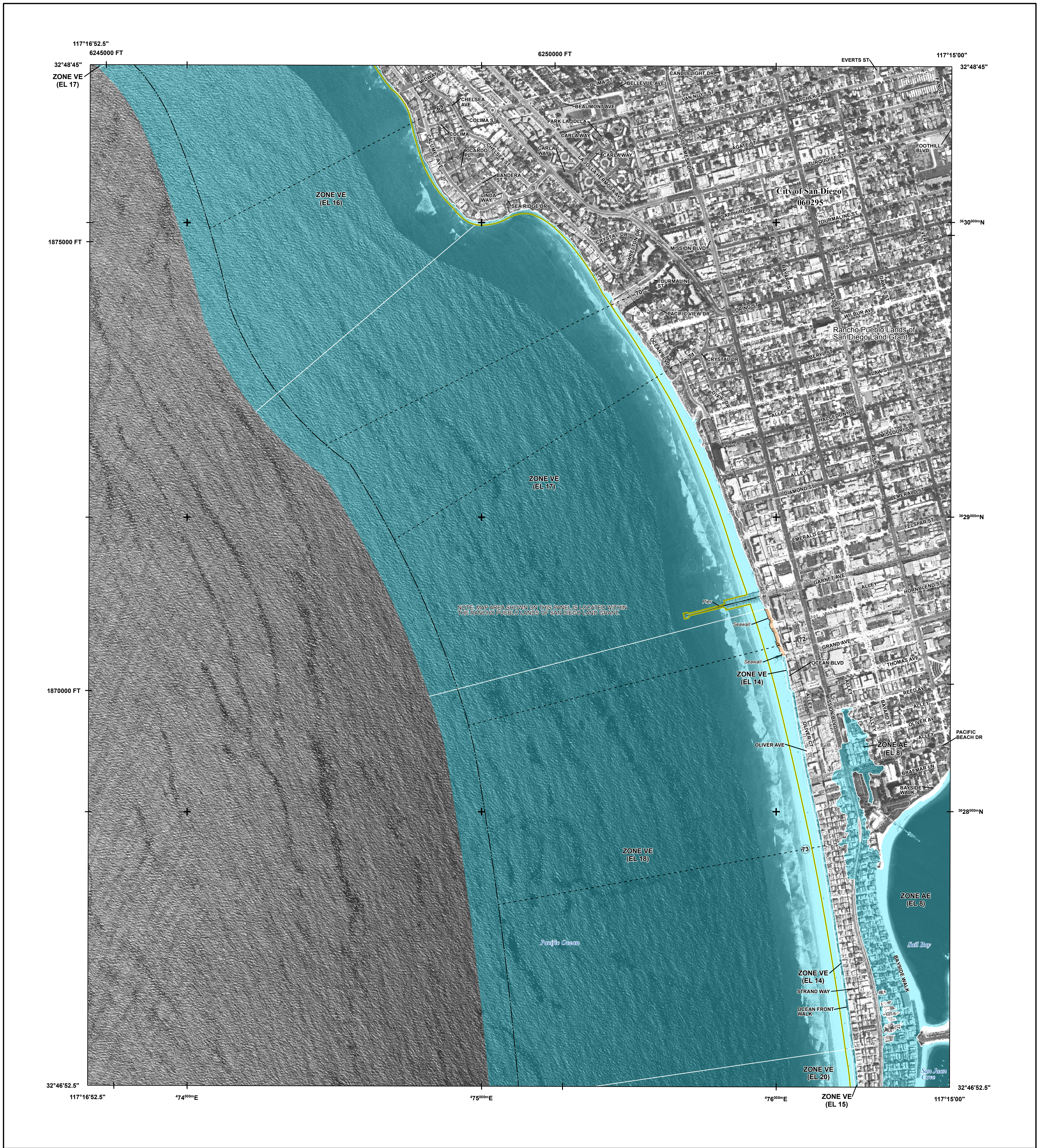

**FLOOD HAZARD INFORMATION**

SEE FIS REPORT FOR DETAILED LEGEND AND INDEX MAP FOR FIRM PANEL LAYOUT  
**THE INFORMATION DEPICTED ON THIS MAP AND SUPPORTING DOCUMENTATION ARE ALSO AVAILABLE IN DIGITAL FORMAT AT [HTTP://MSC.FEMA.GOV](http://MSC.FEMA.GOV)**

<b>SPECIAL FLOOD HAZARD AREAS</b>		Without Base Flood Elevation (BFE) Zone A, V, A99
		With BFE or Depth Zone AE, AO, AH, VE, AR Regulatory Floodway
<b>OTHER AREAS OF FLOOD HAZARD</b>		0.2% Annual Chance Flood Hazard, Areas of 1% annual chance flood with average depth less than one foot or with drainage areas of less than one square mile Zone X
		Future Conditions 1% Annual Chance Flood Hazard Zone X
		Area with Reduced Flood Risk due to Levee See Notes Zone X
<b>OTHER AREAS</b>		Areas of Minimal Flood Hazard Zone X
		Area of Undetermined Flood Hazard Zone D
<b>GENERAL STRUCTURES</b>		Channel, Culvert or Storm Sewer
		Levee, Dike or Floodwall
		Cross Sections with 1% Annual Chance Water Surface Elevation (BFE) 18.2 17.5
		Coastal Transect
		Coastal Transect Baseline
		Profile Baseline
		Hydrographic Feature
<b>OTHER FEATURES</b>		Base Flood Elevation Line (BFE) 513
		Limit of Study
		Jurisdiction Boundary

**NOTES TO USERS**

For information and questions about this Flood Insurance Rate Map (FIRM), available products associated with this FIRM, including historic versions, the current map date for each FIRM panel, how to order products, or the National Flood Insurance Program (NFIP) in general, please call the FEMA Map Information eXchange at 1-877-FEMA-MAP (1-877-336-2627) or visit the FEMA Flood Map Service Center website at <http://msc.fema.gov>. Available products may include previously issued Letters of Map Change, a Flood Insurance Study Report, and/or digital versions of this map. Many of these products can be ordered or obtained directly from the website.

Communities annexing land on adjacent FIRM panels must obtain a current copy of the adjacent panel as well as the current FIRM Index. These may be ordered directly from the Flood Map Service Center at the number listed above.

For community and countywide map dates refer to the Flood Insurance Study report for this jurisdiction.

To determine if flood insurance is available in this community, contact your Insurance agent or call the National Flood Insurance Program at 1-800-638-6620.

Base map information shown on this FIRM was derived from digital orthophotography collected by the Coastal Service Center and U.S. Department of Agriculture Farm Service Agency. Coastal Service Center imagery was flown in 2011 and was produced with a sub-meter ground sample distance. Department of Agriculture imagery was flown in 2016 and was produced with a 1-meter ground sample distance.

**SCALE**

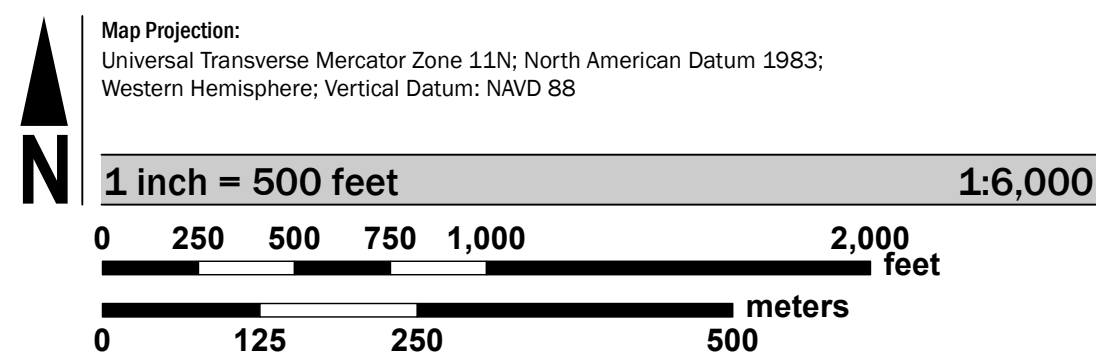

**PANEL LOCATOR**

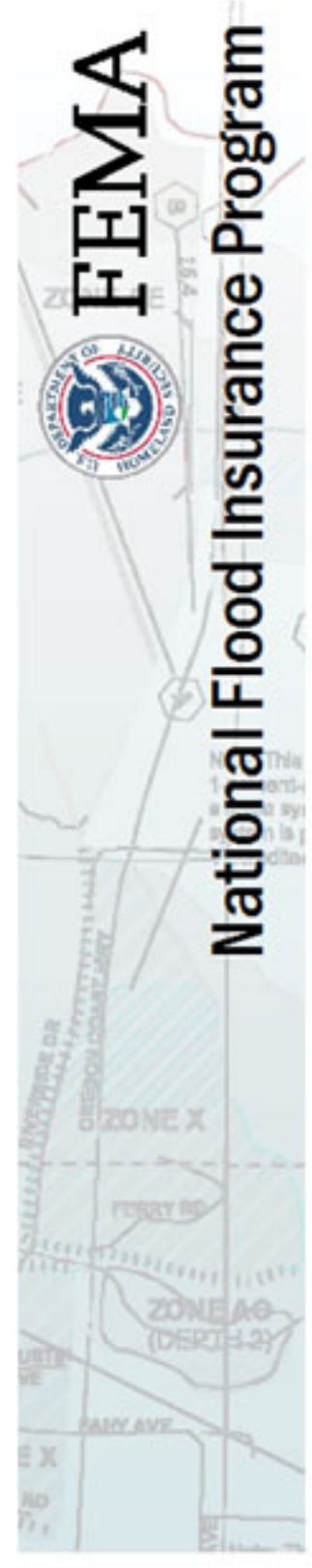
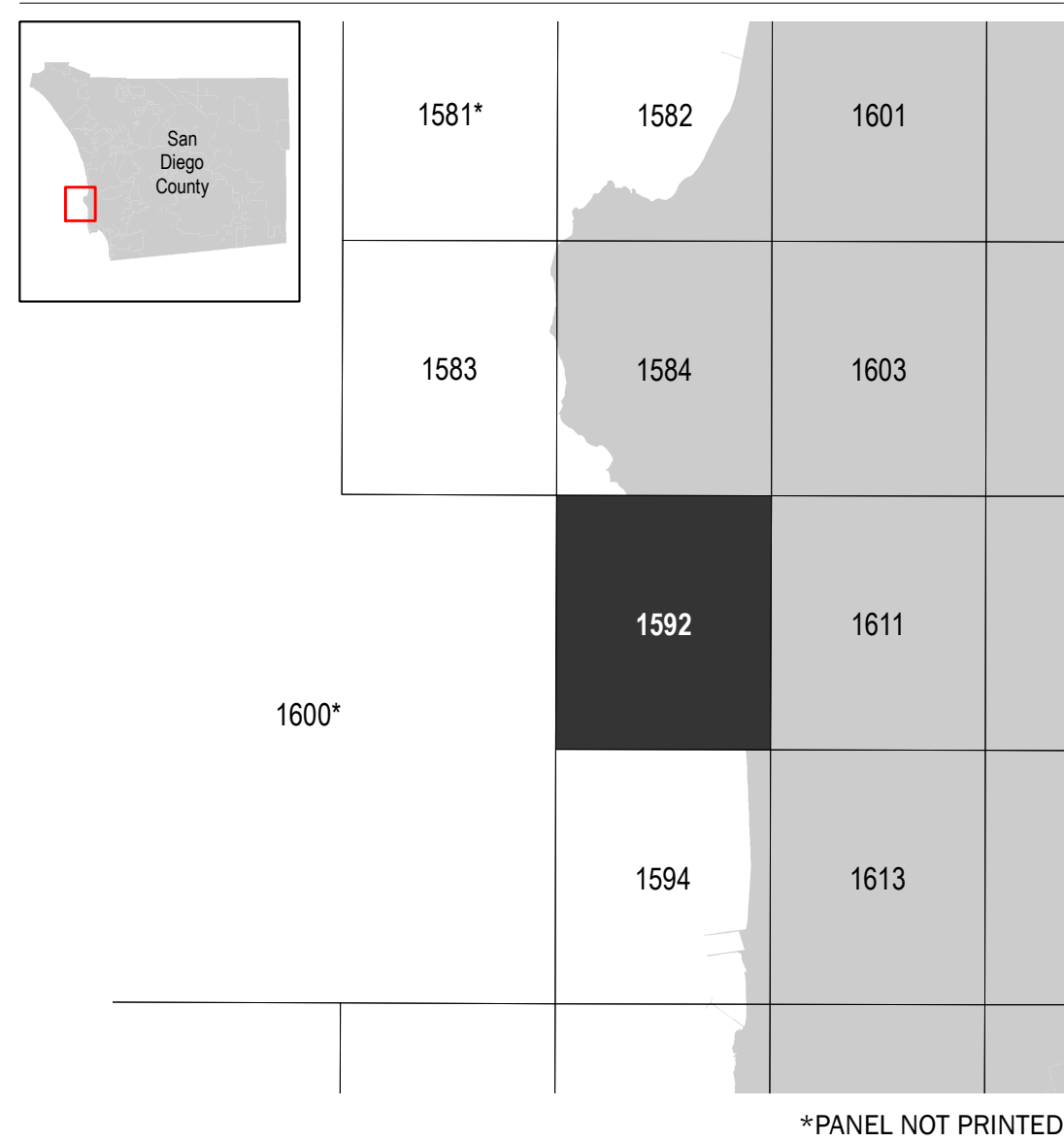

**NATIONAL FLOOD INSURANCE PROGRAM**  
 FLOOD INSURANCE RATE MAP  
 SAN DIEGO COUNTY, CALIFORNIA  
 and Incorporated Areas  
 PANEL 1592 OF 2375

Panel Contains:  
 COMMUNITY SAN DIEGO, CITY OF  
 NUMBER PANEL SUFFIX  
 060295 1592 H

**PRELIMINARY**  
 2/3/2017

VERSION NUMBER  
 2.3.3.3  
 MAP NUMBER  
 06073C1592H  
 MAP REVISED

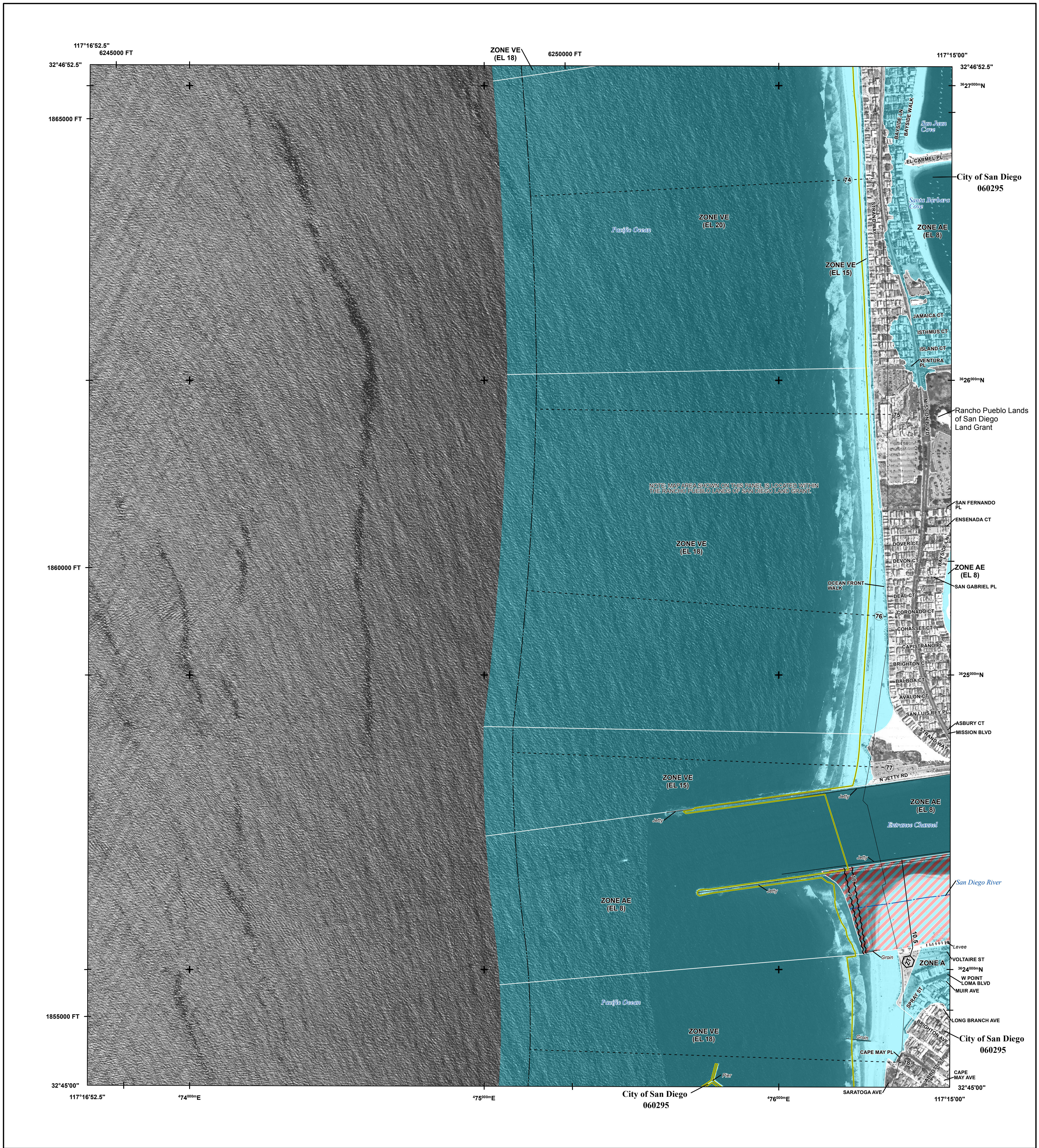

**FLOOD HAZARD INFORMATION**

SEE FIS REPORT FOR DETAILED LEGEND AND INDEX MAP FOR FIRM PANEL LAYOUT  
**THE INFORMATION DEPICTED ON THIS MAP AND SUPPORTING DOCUMENTATION ARE ALSO AVAILABLE IN DIGITAL FORMAT AT [HTTP://MSC.FEMA.GOV](http://MSC.FEMA.GOV)**

<b>SPECIAL FLOOD HAZARD AREAS</b>		Without Base Flood Elevation (BFE) Zone A, V, A99
		With BFE or Depth Zone AE, AO, AH, VE, AR Regulatory Floodway
<b>OTHER AREAS OF FLOOD HAZARD</b>		0.2% Annual Chance Flood Hazard, Areas of 1% annual chance flood with average depth less than one foot or with drainage areas of less than one square mile Zone X
		Future Conditions 1% Annual Chance Flood Hazard Zone X
		Area with Reduced Flood Risk due to Levee See Notes Zone X
<b>OTHER AREAS</b>		Areas of Minimal Flood Hazard Zone X
		Area of Undetermined Flood Hazard Zone D
<b>GENERAL STRUCTURES</b>		Channel, Culvert or Storm Sewer
		Levee, Dike or Floodwall
		Cross Sections with 1% Annual Chance Water Surface Elevation (BFE) 18.2 17.5
		Coastal Transect
		Coastal Transect Baseline
		Profile Baseline
		Hydrographic Feature
<b>OTHER FEATURES</b>		Base Flood Elevation Line (BFE)
		Limit of Study
		Jurisdiction Boundary

**NOTES TO USERS**

For information and questions about this Flood Insurance Rate Map (FIRM), available products associated with this FIRM, including historic versions, the current map date for each FIRM panel, how to order products, or the National Flood Insurance Program (NFIP) in general, please call the FEMA Map Information eXchange at 1-877-FEMA-MAP (1-877-336-2627) or visit the FEMA Flood Map Service Center website at <http://msc.fema.gov>. Available products may include previously issued Letters of Map Change, a Flood Insurance Study Report, and/or digital versions of this map. Many of these products can be ordered or obtained directly from the website.

Communities annexing land on adjacent FIRM panels must obtain a current copy of the adjacent panel as well as the current FIRM Index. These may be ordered directly from the Flood Map Service Center at the number listed above.

For community and countywide map dates refer to the Flood Insurance Study report for this jurisdiction.

To determine if flood insurance is available in this community, contact your Insurance agent or call the National Flood Insurance Program at 1-800-638-6620.

Base map information shown on this FIRM was derived from digital orthophotography collected by the Coastal Service Center and U.S. Department of Agriculture Farm Service Agency. Coastal Service Center imagery was flown in 2011 and was produced with a sub-meter ground sample distance. Department of Agriculture imagery was flown in 2014 and was produced with a 1-meter ground sample distance.

**PROVISIONALLY ACCREDITED LEVEE:** Check with your local community to obtain more information, such as the estimated level of protection provided (which may exceed the 1-percent-annual-chance level) and Emergency Action Plan, on the levee system(s) shown as providing protection for areas on this panel. To maintain accreditation, the levee owner or community is required to submit the data and documentation necessary to comply with Section 65.10 of the NFIP regulations by July 23, 2009. If the community or owner does not provide the necessary data and documentation or if the data and documentation provided indicate the levee system does not comply with Section 65.10 requirements, FEMA will revise the flood hazard and risk information for this area to reflect de-accreditation of the levee system. To mitigate flood risk in residual risk areas, property owners and residents are encouraged to consider flood insurance and floodproofing or other protective measures. For more information on flood insurance, interested parties should visit <http://www.fema.gov/national-flood-insurance-program>.

**SCALE**

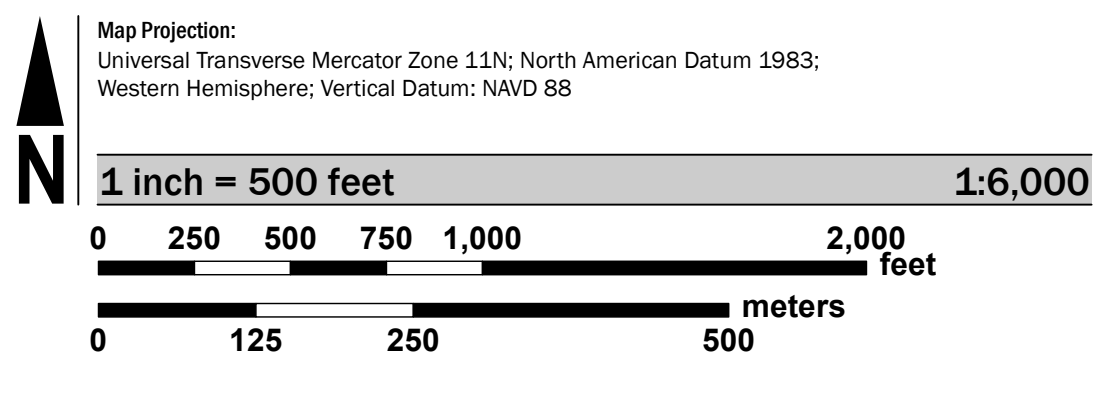

**PANEL LOCATOR**

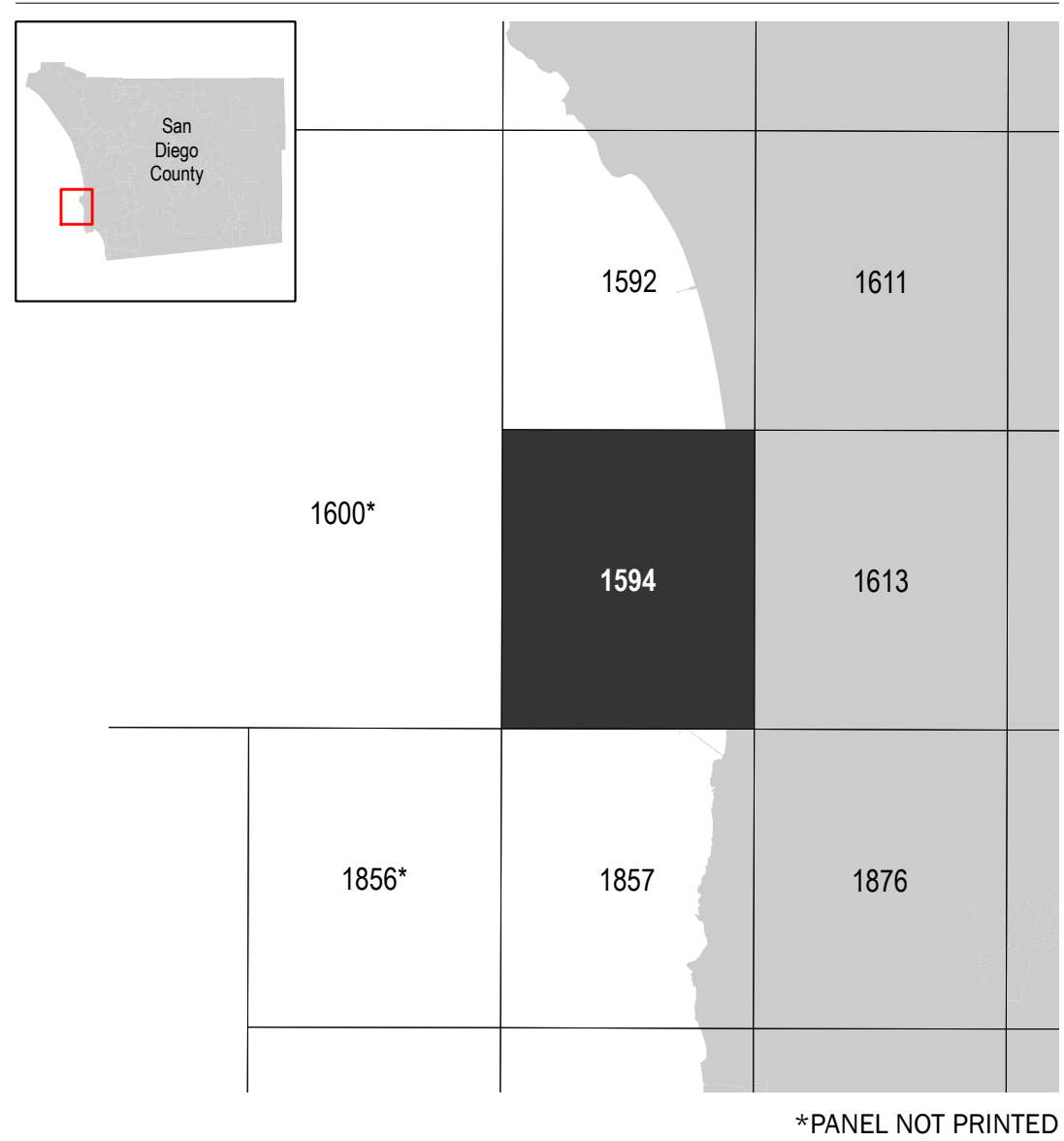

**FEMA**  
**National Flood Insurance Program**

**NATIONAL FLOOD INSURANCE PROGRAM**  
**FLOOD INSURANCE RATE MAP**  
**SAN DIEGO COUNTY, CALIFORNIA**  
 and Incorporated Areas  
**PANEL 1594 OF 2375**

Panel Contains:  
 COMMUNITY NUMBER PANEL SUFFIX  
 SAN DIEGO, CITY OF 060295 1594 H

**PRELIMINARY**  
**2/3/2017**

VERSION NUMBER 2.3.3.3  
 MAP NUMBER 06073C1594H  
 MAP REVISED

## **B. Preliminary Drawings**



# MISSION BEACH SEAWALL IMPROVEMENTS FEASIBILITY STUDY

SHEET INDEX		
INDEX #	SHEET #	SHEET TITLE
1	G-1	COVER SHEET
2	C-1	PARTIAL PLAN - 1
3	C-2	PARTIAL PLAN - 2
4	C-3	PARTIAL PLAN - 3
5	C-4	PARTIAL PLAN - 4
6	C-5	PARTIAL PLAN - 5
7	C-6	PARTIAL PLAN - 6
8	C-7	SEGMENT C WALL LAYOUT
9	S-1	SEGMENT A EXISTING SEAWALL
10	S-2	SEGMENT A OPTION 1: PARAPET REPLACEMENT
11	S-3	SEGMENT A OPTION 2: RAISED BOARDWALK
12	S-4	SEGMENT A TYPICAL VOID REPAIR
13	S-5	SEGMENT B PARAPET REPLACEMENT
14	S-6	SEGMENT C OPTION 1: SEAWALL
15	S-7	SEGMENT C OPTION 2: DECORATIVE WALL
16	S-8	DRIVEWAY
17	S-9	TYPICAL BEACH ACCESS STAIR
18	S-10	TYPICAL BEACH ACCESS RAMP - LAYOUT
19	S-11	TYPICAL BEACH ACCESS RAMP - DETAILS NO. 1
20	S-12	TYPICAL BEACH ACCESS RAMP - DETAILS NO. 2
21	R-1	REFERENCE: EXISTING BEACH ACCESS STAIR

**ABBREVIATIONS**

CY	CUBIC YARD
EL, ELEV	ELEVATION
EX, EXIST	EXISTING
FG	FINISH GRADE
FT	FEET
RCB	REINFORCED CONCRETE BOX
RCP	REINFORCED CONCRETE PIPE
SD	STORM DRAIN
TYP	TYPICAL
IE	INVERT ELEVATION
MIN	MINIMUM
PROP	PROPOSED
MIN	MINIMUM

**DISCIPLINE CODE**

G	GENERAL
C	CIVIL
S	STRUCTURAL
R	REFERENCE

**LEGEND**

	PROJECT BOUNDARY
	EXISTING CONTOUR
	INTERNATIONAL BORDER
	EXISTING ROADWAY
	EXISTING HIGHWAY
	BENCHMARK STRUCTURE
	SECTION A EXTENT
	SECTION B EXTENT
	SECTION C EXTENT

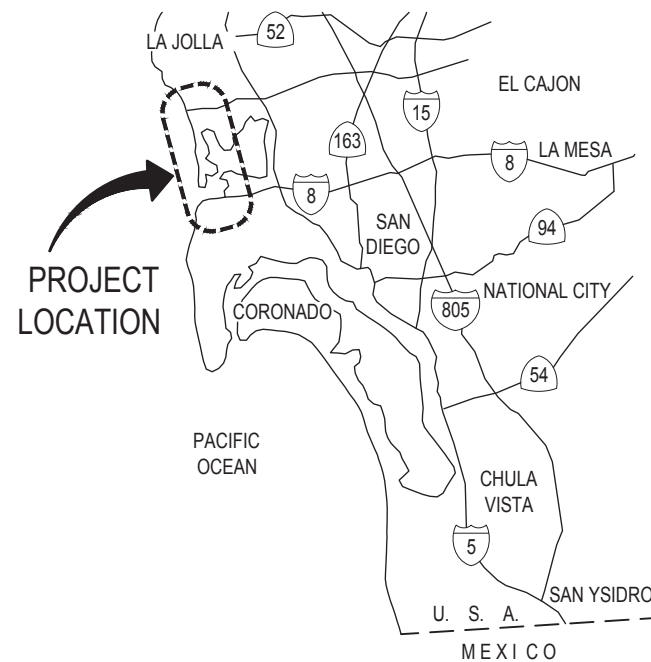

PROJECT AREA

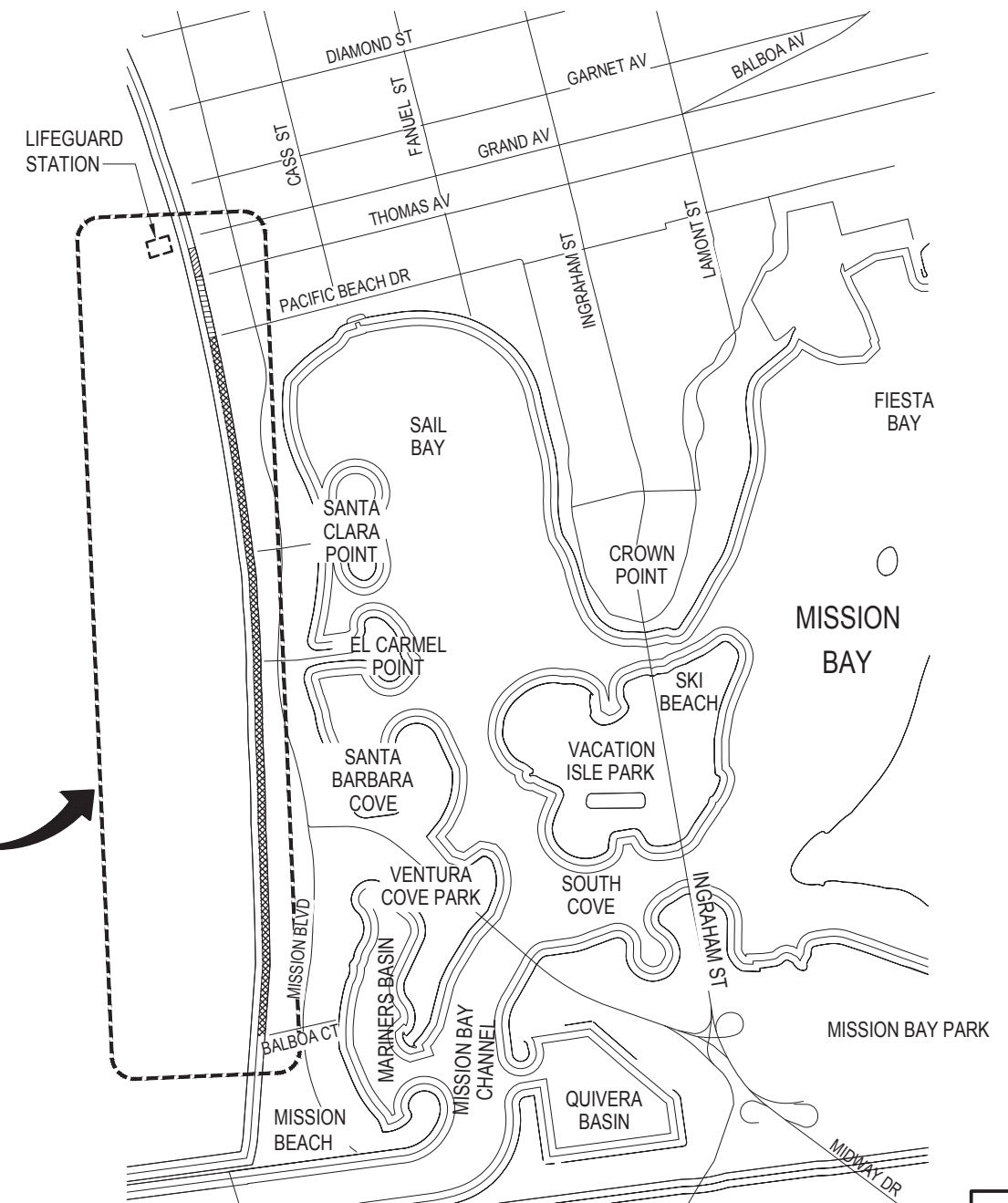

G-1

**PRELIMINARY  
NOT FOR CONSTRUCTION**

CONSTRUCTION CHANGE / ADDENDUM			
CHANGE	DATE	AFFECTED OR ADDED SHEET NUMBERS	APPROVAL NO.

**WARNING**  
0 1  
  
IF THIS BAR DOES NOT MEASURE 1" THEN DRAWING IS NOT TO SCALE.



**moffatt & nichol**

1660 HOTEL CIRCLE NORTH, SUITE 500  
SAN DIEGO, CALIFORNIA 92108  
PH (619) 220-6050 FAX (619) 220-6055

MISSION BEACH SEAWALL IMPROVEMENTS FEASIBILITY STUDY COVER SHEET			
SPEC. NO.		CITY OF SAN DIEGO, CALIFORNIA PUBLIC WORKS DEPARTMENT SHEET OF SHEETS	
APPROVED: FOR CITY ENGINEER _____ DATE _____ PRINT NAME _____ RCE# _____		SUBMITTED BY: PROJECT MANAGER _____ CHECKED BY: PROJECT ENGINEER _____	
DESCRIPTION	BY	APPROVED	DATE FILMED
ORIGINAL	REC		
CONTRACTOR INSPECTOR _____		DATE STARTED _____ DATE COMPLETED _____	
		CCS27 COORDINATE _____ CCS83 COORDINATE _____	

FILE NAME: C:\SDA\10278 - Mission Bay PER\10278 (M. Seawall)\\_Active\\_Design\01\_GENERAL\10278-FG-G1.dwg  
PLOTTER: Tuesday, October 11, 2022 - 5:34pm USER: aburra

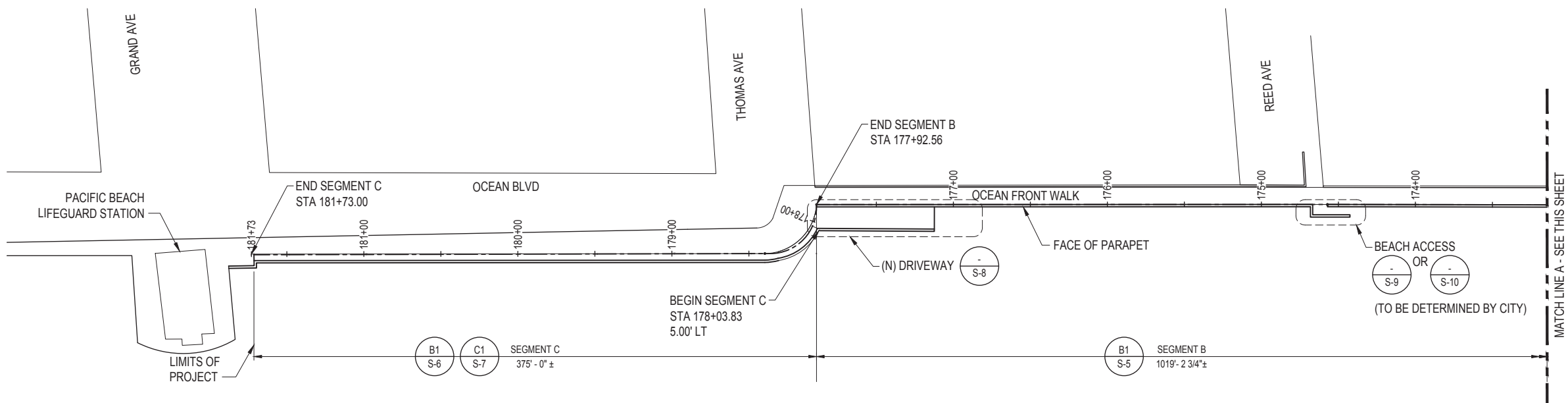

**C1 PLAN - MISSION BEACH BOARDWALK**  
SCALE: NTS

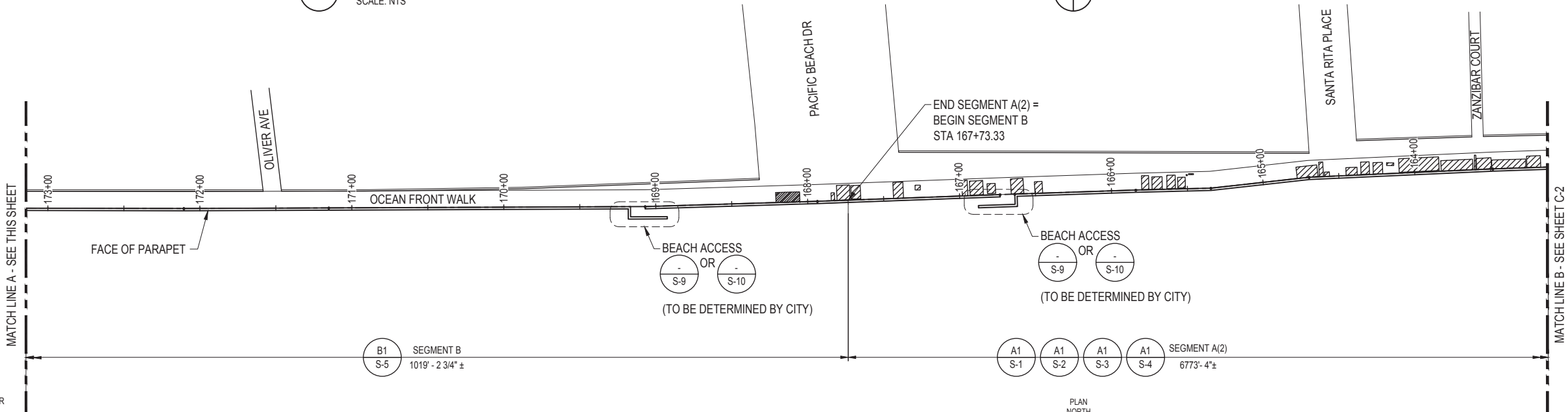

**A1 PLAN - MISSION BEACH BOARDWALK**  
SCALE: NTS

**LEGEND**  
 POTENTIAL VOIDS UNDER SIDEWALK. SEE VOID MAPPING DISCLAIMER.

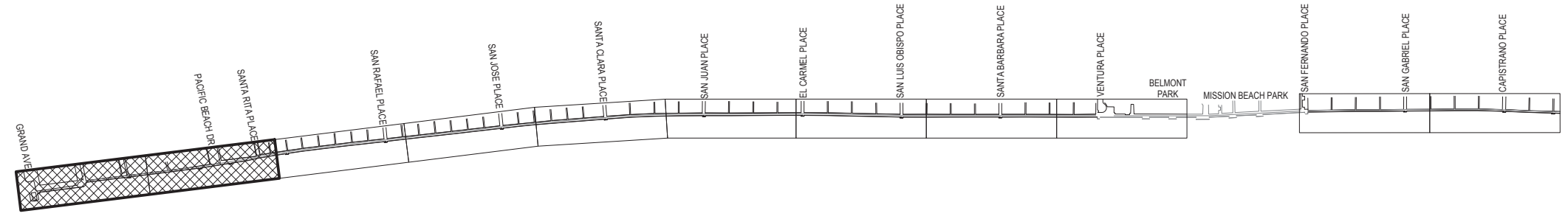

**OVERALL KEY PLAN**  
NOT TO SCALE

**PRELIMINARY**  
NOT FOR CONSTRUCTION

**C-1**

**MISSION BEACH SEAWALL IMPROVEMENTS FEASIBILITY STUDY**

**PARTIAL PLAN - 1**

CITY OF SAN DIEGO, CALIFORNIA  
PUBLIC WORKS DEPARTMENT  
SHEET OF SHEETS

APPROVED:	FOR CITY ENGINEER	DATE	PROJECT MANAGER	
PRINT NAME	RCE#	CHECKED BY:	PROJECT ENGINEER	
DESCRIPTION	BY	APPROVED	DATE	FILMED
ORIGINAL	REC			

CONTRACTOR INSPECTOR \_\_\_\_\_ DATE STARTED \_\_\_\_\_ DATE COMPLETED \_\_\_\_\_

FILE NAME: C:\SDA\10278 - Mission Bay FERR\1001\06 Seawall\1\_Active\Design\02 CIML\10278-F6-01.dwg  
PLOTTER: Monby, October 17, 2022 - 10:48am USER: abrown

**VOID MAPPING DISCLAIMER:** These drawings were prepared, in part, based upon information furnished by others. While this information is believed to be reliable, the engineer cannot assure its accuracy, and thus is not responsible for the accuracy of this map or any errors or omissions which may have been incorporated into it as a result. Those relying on void information provided in these drawings are advised to obtain independent verification of its accuracy before applying it to Final Engineering Design or any other purpose.

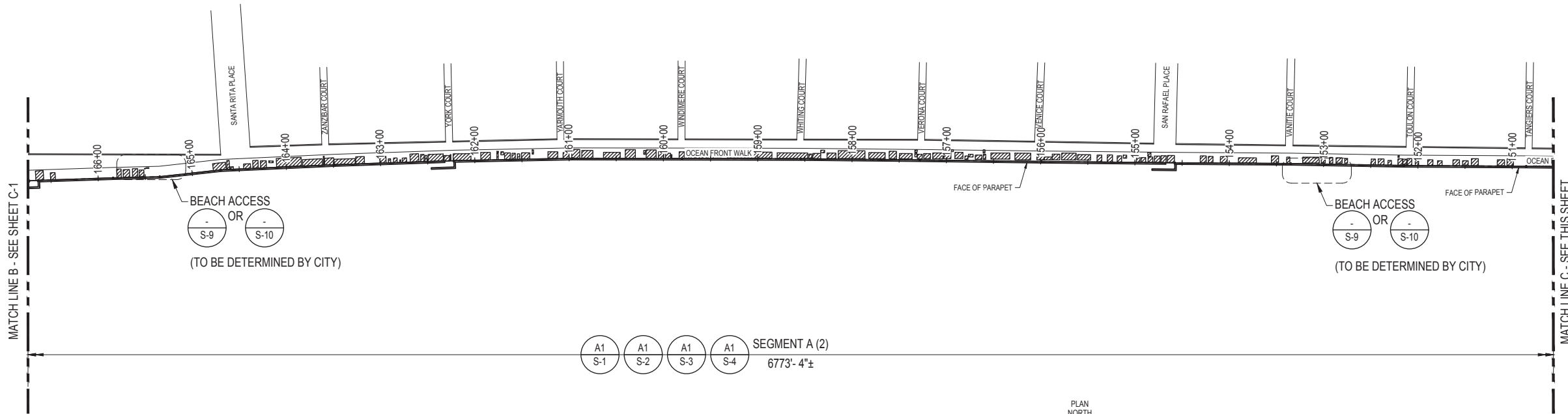

**C1** PLAN - MISSION BEACH BOARDWALK  
SCALE: NTS

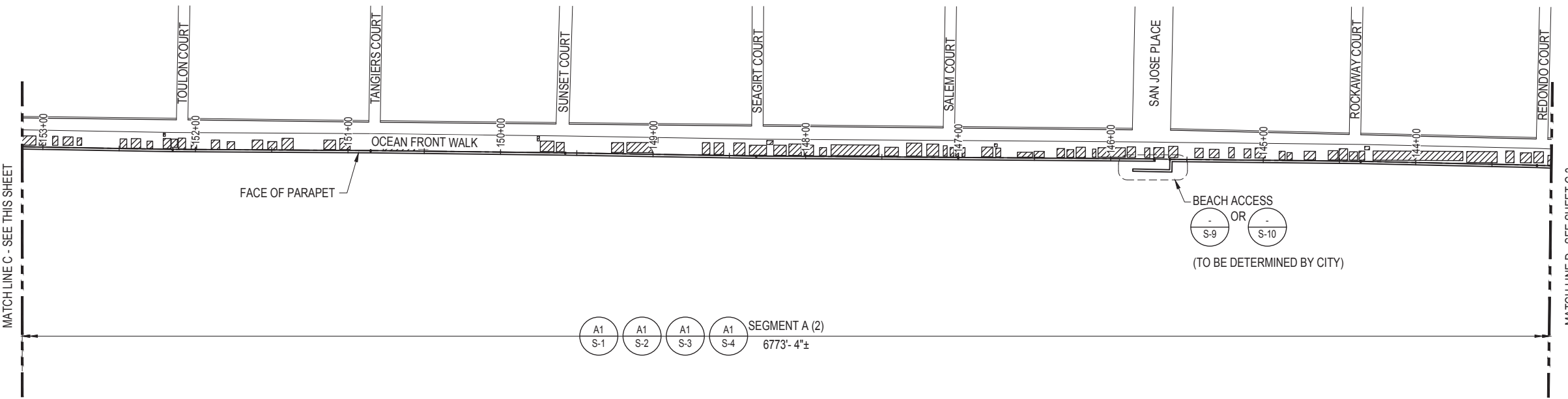

**A1** PLAN - MISSION BEACH BOARDWALK  
SCALE: NTS

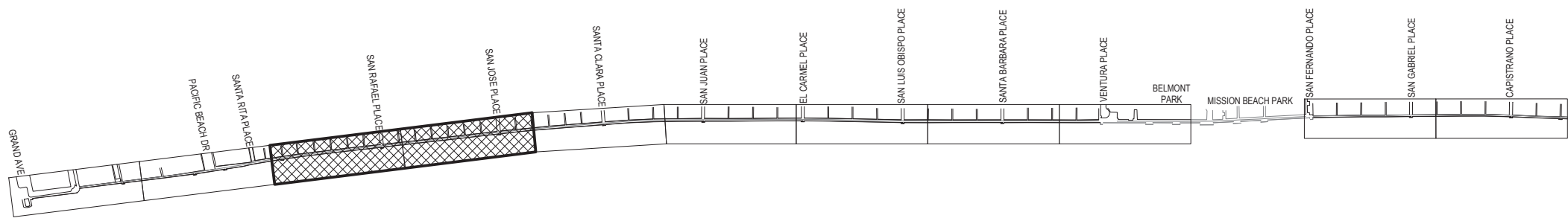

**OVERALL KEY PLAN**  
NOT TO SCALE

**PRELIMINARY**  
NOT FOR CONSTRUCTION

**LEGEND**  
 POTENTIAL VOIDS UNDER SIDEWALK. SEE VOID MAPPING DISCLAIMER.

**VOID MAPPING DISCLAIMER:** These drawings were prepared, in part, based upon information furnished by others. While this information is believed to be reliable, the engineer cannot assure its accuracy, and thus is not responsible for the accuracy of this map or any errors or omissions which may have been incorporated into it as a result. Those relying on void information provided in these drawings are advised to obtain independent verification of its accuracy before applying it to Final Engineering Design or any other purpose.

**MISSION BEACH SEAWALL IMPROVEMENTS FEASIBILITY STUDY**

**PARTIAL PLAN - 2**

CITY OF SAN DIEGO, CALIFORNIA  
PUBLIC WORKS DEPARTMENT  
SHEET OF SHEETS

WBS \_\_\_\_\_

APPROVED:	FOR CITY ENGINEER _____	DATE _____	PRINT NAME _____	RCE# _____	DESCRIPTION	BY	APPROVED	DATE	FILMED	PROJECT ENGINEER
					ORIGINAL	REC				CCS27 COORDINATE
										CCS83 COORDINATE

CONTRACTOR \_\_\_\_\_ DATE STARTED \_\_\_\_\_  
INSPECTOR \_\_\_\_\_ DATE COMPLETED \_\_\_\_\_

**C-2**

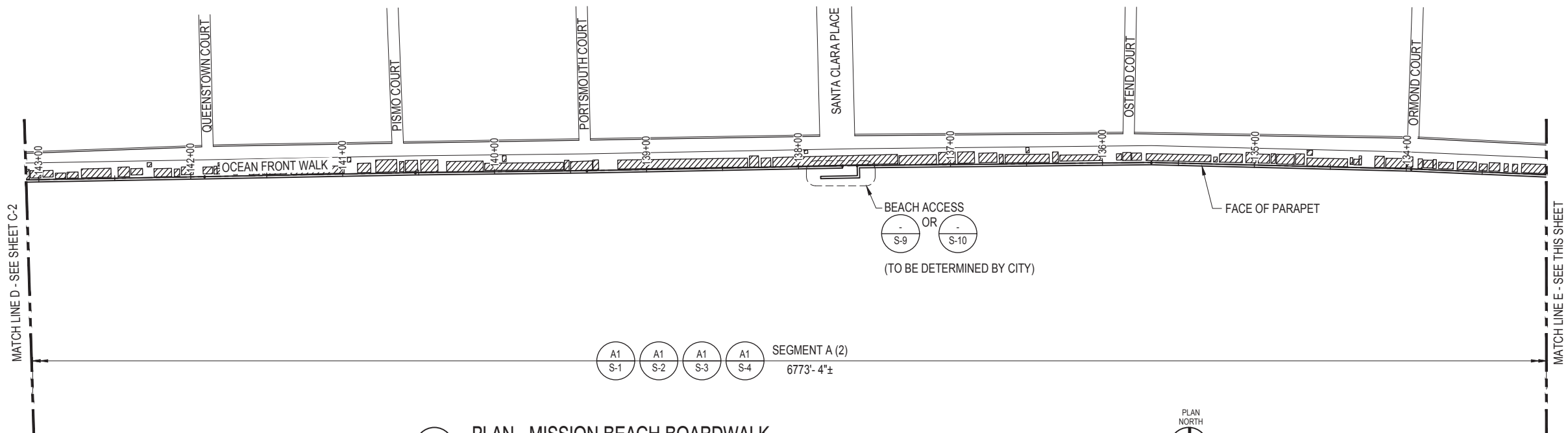

**C1 PLAN - MISSION BEACH BOARDWALK**  
SCALE: NTS

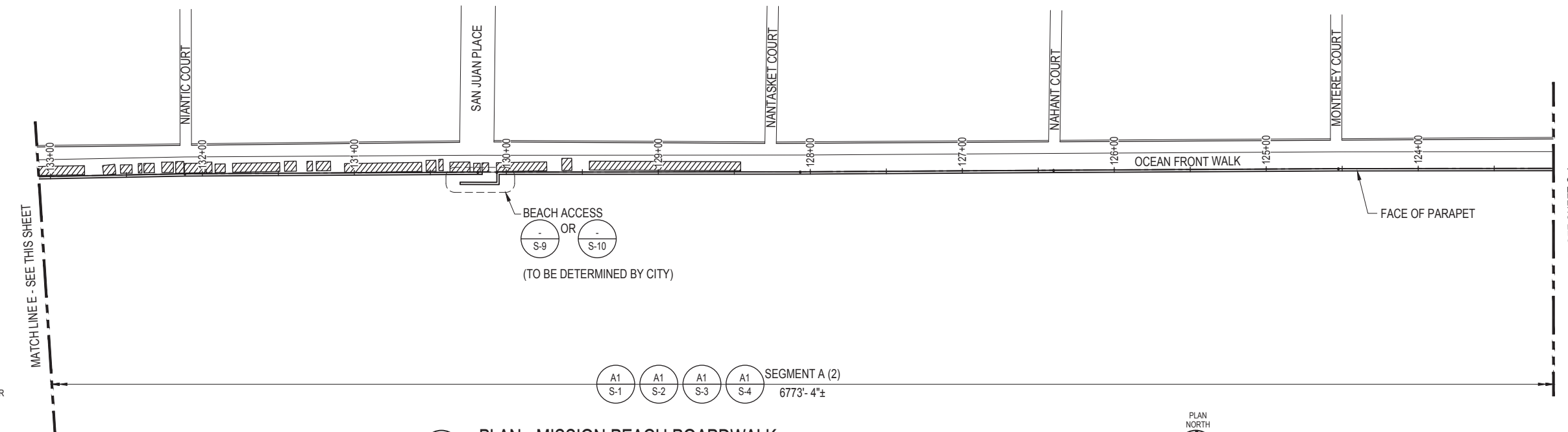

**A1 PLAN - MISSION BEACH BOARDWALK**  
SCALE: NTS

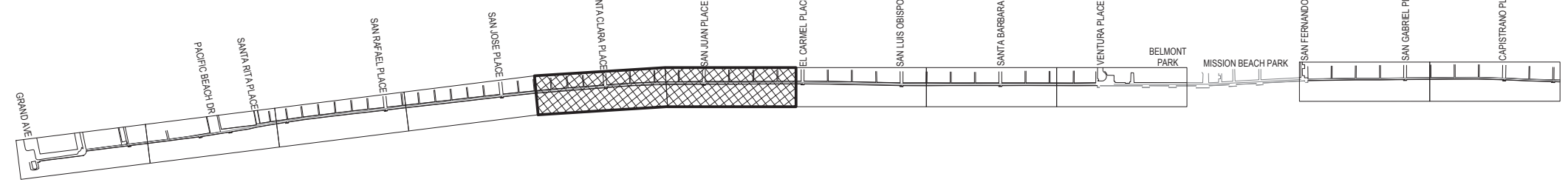

**OVERALL KEY PLAN**  
NOT TO SCALE

**LEGEND**  
 POTENTIAL VOIDS UNDER SIDEWALK. SEE VOID MAPPING DISCLAIMER.

**VOID MAPPING DISCLAIMER:** These drawings were prepared, in part, based upon information furnished by others. While this information is believed to be reliable, the engineer cannot assure its accuracy, and thus is not responsible for the accuracy of this map or any errors or omissions which may have been incorporated into it as a result. Those relying on void information provided in these drawings are advised to obtain independent verification of its accuracy before applying it to Final Engineering Design or any other purpose.

**PRELIMINARY**  
NOT FOR CONSTRUCTION

**C-3**

**MISSION BEACH SEAWALK IMPROVEMENTS FEASIBILITY STUDY**

**PARTIAL PLAN - 3**

CITY OF SAN DIEGO, CALIFORNIA  
PUBLIC WORKS DEPARTMENT  
SHEET OF SHEETS

APPROVED:		DATE		SUBMITTED BY:	
FOR CITY ENGINEER				PROJECT MANAGER	
PRINT NAME		RCE#		CHECKED BY:	
DESCRIPTION		BY	APPROVED	DATE	FILMED
ORIGINAL	REC				
				CCS27 COORDINATE	
				CCS83 COORDINATE	

CONTRACTOR \_\_\_\_\_ DATE STARTED \_\_\_\_\_  
INSPECTOR \_\_\_\_\_ DATE COMPLETED \_\_\_\_\_

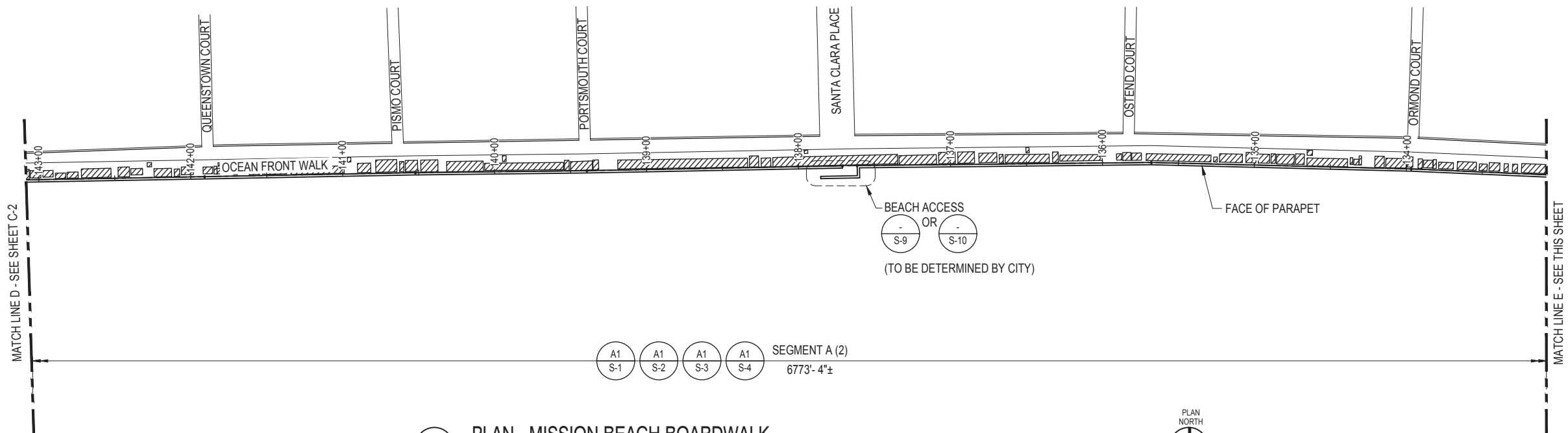

**C1 PLAN - MISSION BEACH BOARDWALK**  
SCALE: NTS

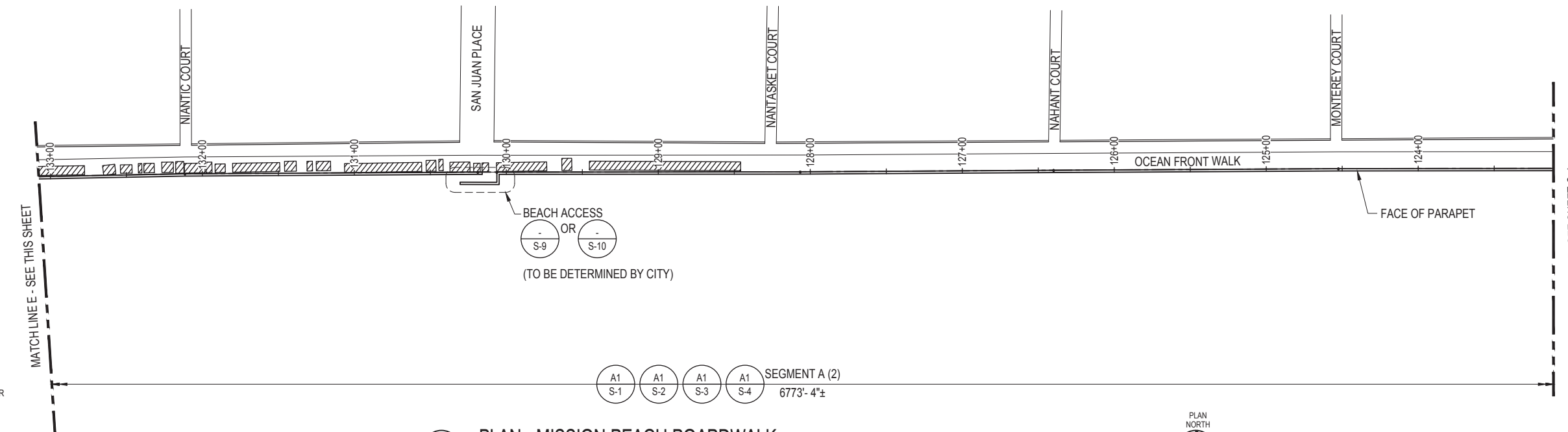

**A1 PLAN - MISSION BEACH BOARDWALK**  
SCALE: NTS

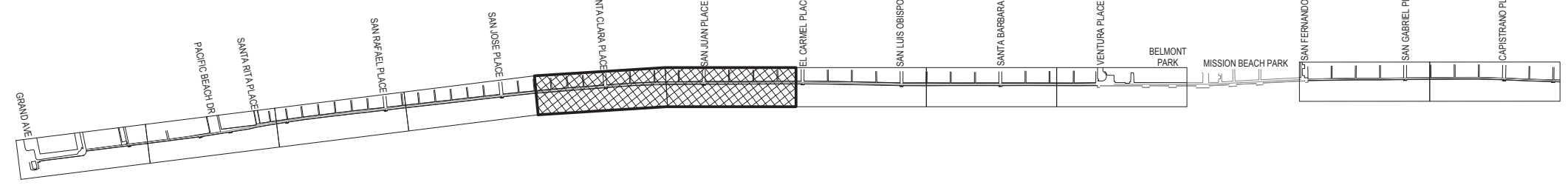

**OVERALL KEY PLAN**  
NOT TO SCALE

**LEGEND**  
 POTENTIAL VOIDS UNDER SIDEWALK. SEE VOID MAPPING DISCLAIMER.

**VOID MAPPING DISCLAIMER:** These drawings were prepared, in part, based upon information furnished by others. While this information is believed to be reliable, the engineer cannot assure its accuracy, and thus is not responsible for the accuracy of this map or any errors or omissions which may have been incorporated into it as a result. Those relying on void information provided in these drawings are advised to obtain independent verification of its accuracy before applying it to Final Engineering Design or any other purpose.

**PRELIMINARY**  
NOT FOR CONSTRUCTION

**C-3**

**MISSION BEACH SEAWALL IMPROVEMENTS FEASIBILITY STUDY**

**PARTIAL PLAN - 3**

CITY OF SAN DIEGO, CALIFORNIA  
PUBLIC WORKS DEPARTMENT  
SHEET OF SHEETS

APPROVED:		DATE		SUBMITTED BY:	
FOR CITY ENGINEER				PROJECT MANAGER	
PRINT NAME		RCE#		CHECKED BY:	
DESCRIPTION		BY	APPROVED	DATE	FILMED
ORIGINAL	REC				

CONTRACTOR \_\_\_\_\_ DATE STARTED \_\_\_\_\_  
INSPECTOR \_\_\_\_\_ DATE COMPLETED \_\_\_\_\_

FILE NAME: C:\SDA\10278 - Mission Bay FFR\CADD\B Seawall\Drawings\Design\02\_Civil\10278-FR-03.dwg  
PLOTTER: Tandy, October 11, 2022 - 5:17pm USER: aburra

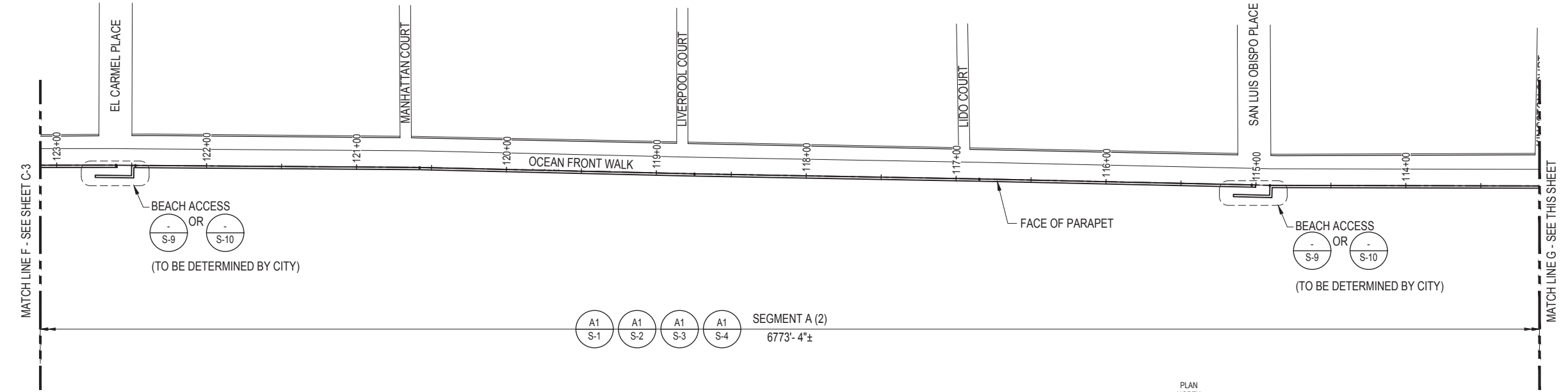

**C1 PLAN - MISSION BEACH BOARDWALK**  
SCALE: NTS

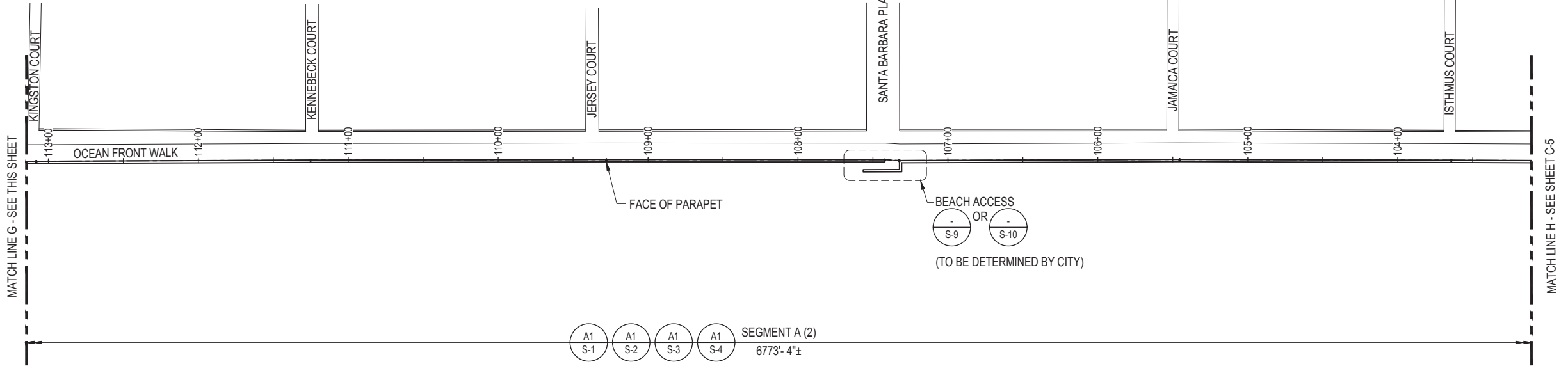

**A1 PLAN - MISSION BEACH BOARDWALK**  
SCALE: NTS

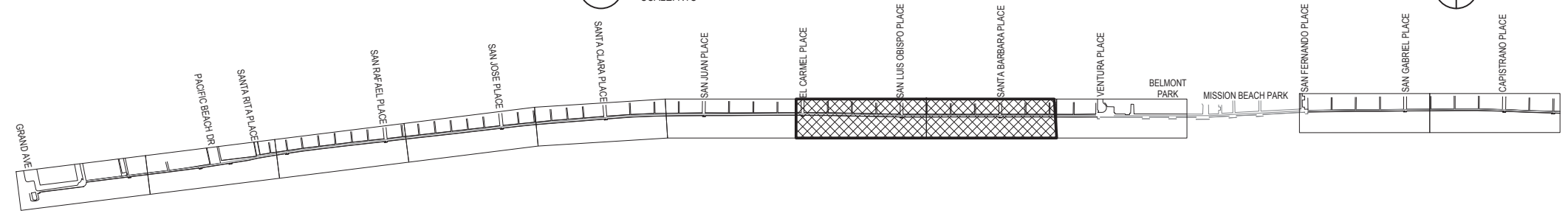

**OVERALL KEY PLAN**  
NOT TO SCALE

**PRELIMINARY**  
NOT FOR CONSTRUCTION

**C - 4**

**MISSION BEACH SEAWALL IMPROVEMENTS FEASIBILITY STUDY**

**PARTIAL PLAN - 4**

CITY OF SAN DIEGO, CALIFORNIA  
PUBLIC WORKS DEPARTMENT  
SHEET OF SHEETS

APPROVED:		DATE		SUBMITTED BY:	
FOR CITY ENGINEER				PROJECT MANAGER	
PRINT NAME		RCE#		CHECKED BY:	
DESCRIPTION		BY	APPROVED	DATE	FILMED
ORIGINAL		REC			

CONTRACTOR \_\_\_\_\_ DATE STARTED \_\_\_\_\_  
INSPECTOR \_\_\_\_\_ DATE COMPLETED \_\_\_\_\_

FILE NAME: C:\SA\10278 - Mission Bay PER\1001\01 - Sewall\1 - Active\Design\02 - CIVIL\10278-FE-04.dwg  
PRINTED: Tuesday, October 11, 2022 - 5:17pm USER: aburru

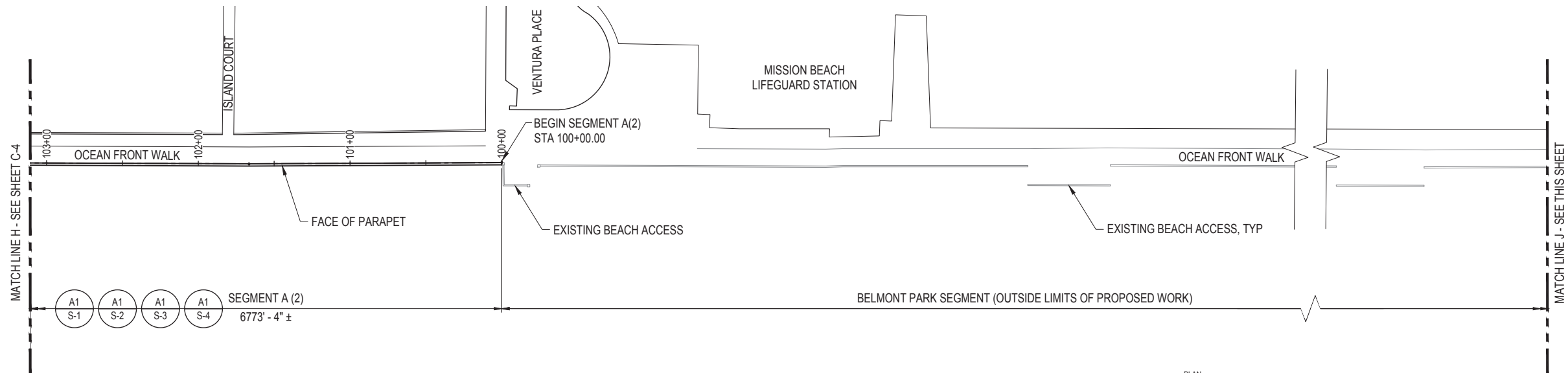

**C1** PLAN - MISSION BEACH BOARDWALK  
SCALE: NTS

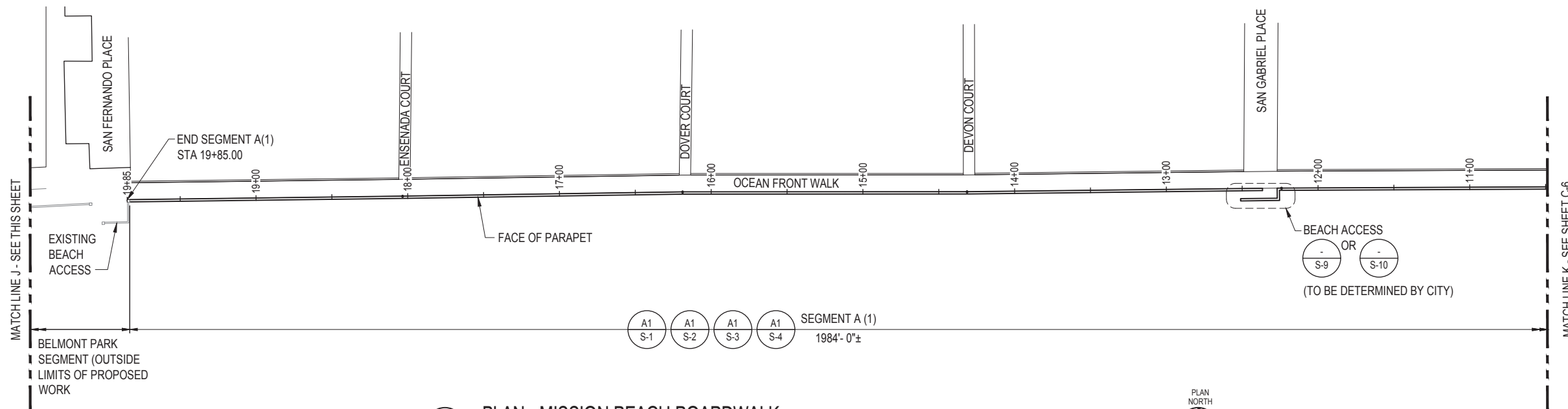

**A1** PLAN - MISSION BEACH BOARDWALK  
SCALE: NTS

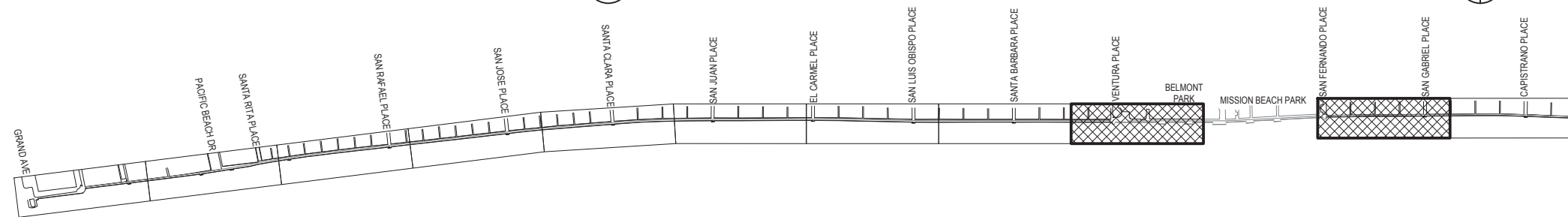

**OVERALL KEY PLAN**  
NOT TO SCALE

**PRELIMINARY**  
NOT FOR CONSTRUCTION

**C-5**

**MISSION BEACH SEAWALL IMPROVEMENTS FEASIBILITY STUDY**

**PARTIAL PLAN - 5**

CITY OF SAN DIEGO, CALIFORNIA  
PUBLIC WORKS DEPARTMENT  
SHEET OF SHEETS

APPROVED:	FOR CITY ENGINEER	DATE	PROJECT MANAGER	
PRINT NAME	RCE#	CHECKED BY:	PROJECT ENGINEER	
DESCRIPTION	BY	APPROVED	DATE	FILMED
ORIGINAL	REC			

CONTRACTOR \_\_\_\_\_ DATE STARTED \_\_\_\_\_  
INSPECTOR \_\_\_\_\_ DATE COMPLETED \_\_\_\_\_

FILE NAME: C:\SDA\10278 - Mission Bay FERR\000\MB Seawall\Drawings\Design\02 CHNL\10278-F5-C5.dwg  
PRINTED: Tuesday, October 11, 2022 - 5:17pm USER: aburru

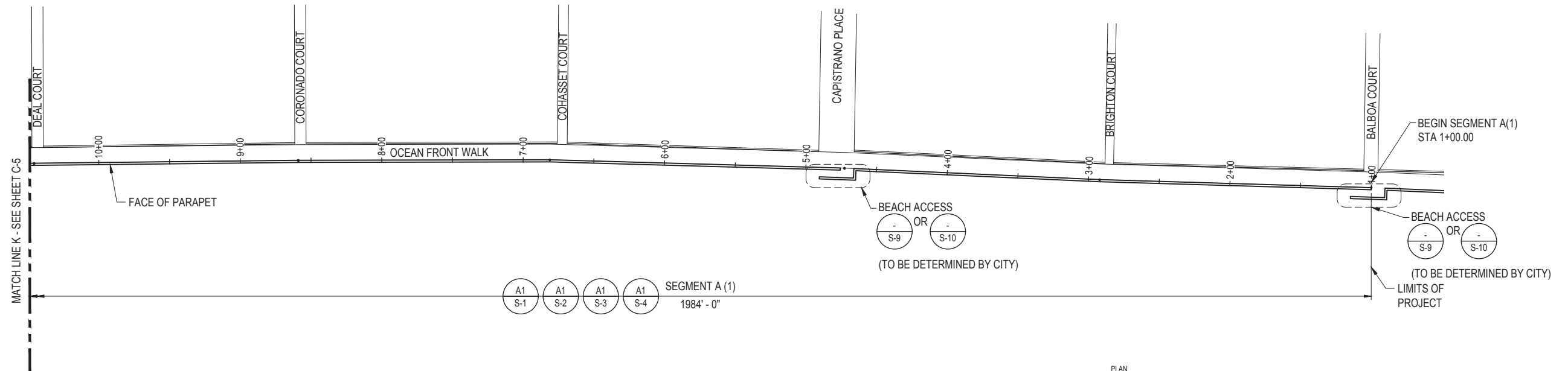

**C1** PLAN - MISSION BEACH BOARDWALK  
SCALE: NTS

PLAN NORTH

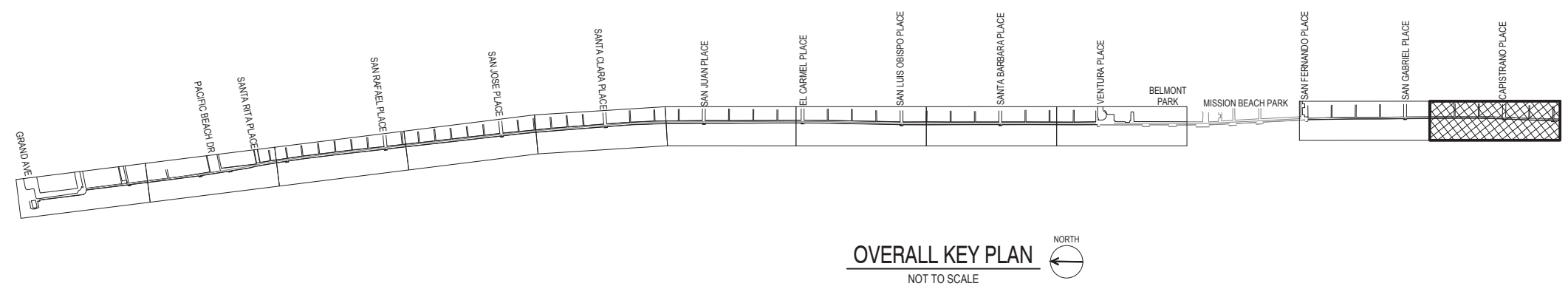

**OVERALL KEY PLAN**  
NOT TO SCALE

**PRELIMINARY**  
NOT FOR CONSTRUCTION

MISSION BEACH SEAWALL IMPROVEMENTS FEASIBILITY STUDY

PARTIAL PLAN - 6

CITY OF SAN DIEGO, CALIFORNIA  
PUBLIC WORKS DEPARTMENT  
SHEET OF SHEETS

APPROVED:		DATE		SUBMITTED BY:	
FOR CITY ENGINEER				PROJECT MANAGER	
PRINT NAME		RCE#		CHECKED BY:	
PROJECT ENGINEER				PROJECT ENGINEER	
DESCRIPTION		BY	APPROVED	DATE	FILMED
ORIGINAL	REC				
				CCS27 COORDINATE	
				CCS83 COORDINATE	

CONTRACTOR \_\_\_\_\_ DATE STARTED \_\_\_\_\_  
INSPECTOR \_\_\_\_\_ DATE COMPLETED \_\_\_\_\_

FILE NAME: C:\SDA\10278 - Mission Bay FERR\000\MB Seawall\Drawings\Design\02 CHL\10278-F6-06.dwg  
PLOTTER: Tuesday, October 11, 2022 - 5:17pm USER: aburrow



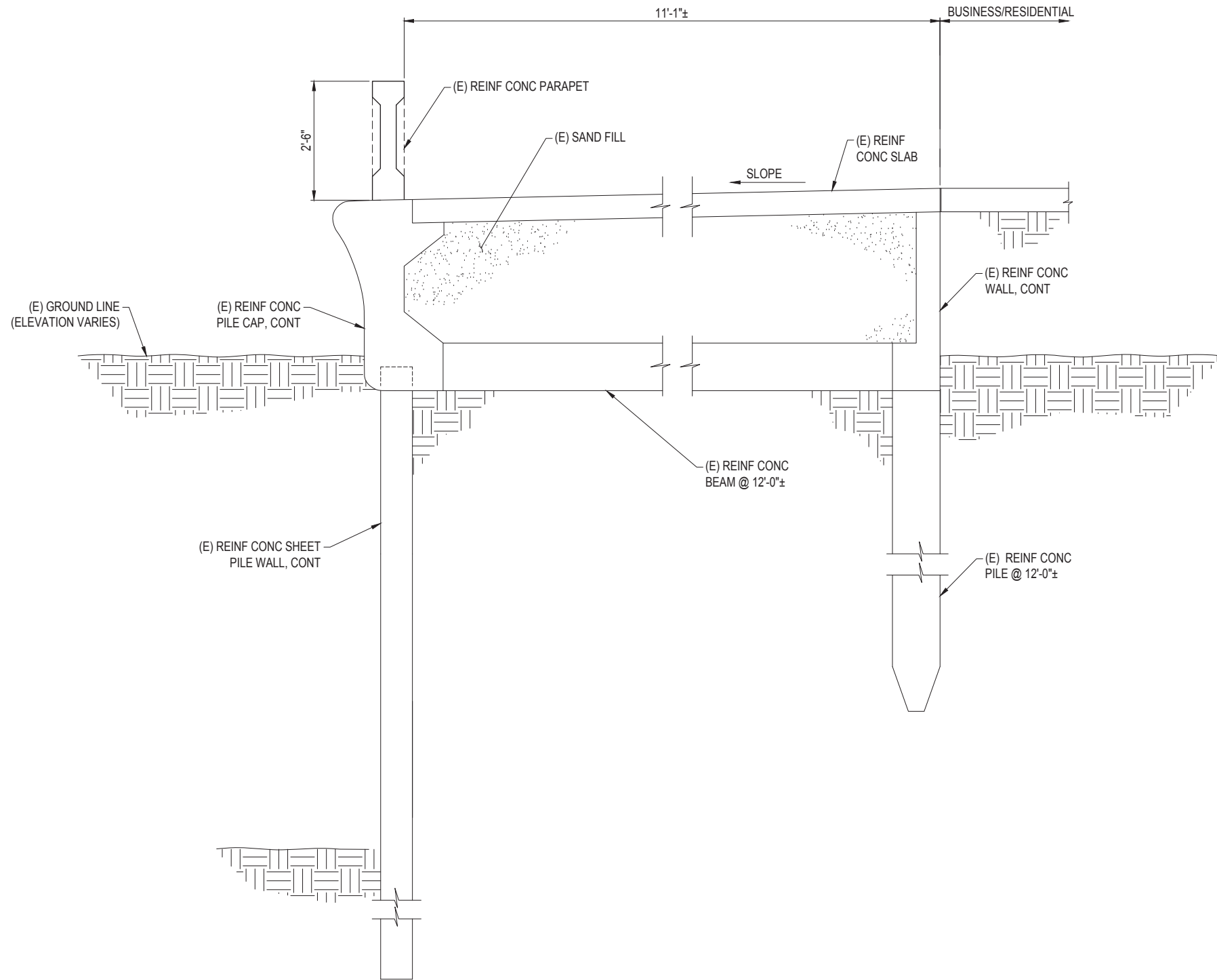

**SEGMENT A - EXISTING SEAWALL**

SCALE: 3/4" = 1'-0"

STA 1+00.00 TO STA 19+85.00  
STA 100+00.00 TO STA 167+73.33

C-1 TO C-6

**A1**



**EXISTING CONDITION - BOARDWALK VIEW**

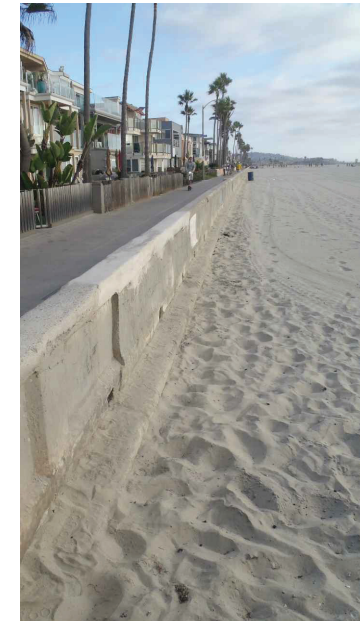

**EXISTING CONDITION - BEACH SIDE VIEW**

**S-1**

**MISSION BEACH SEAWALL IMPROVEMENTS FEASIBILITY STUDY  
SEGMENT A  
EXISTING SEAWALL**

CITY OF SAN DIEGO, CALIFORNIA  
PUBLIC WORKS DEPARTMENT  
SHEET OF SHEETS

WBS \_\_\_\_\_

APPROVED:		SUBMITTED BY:	
FOR CITY ENGINEER	DATE	PROJECT MANAGER	CHECKED BY:
PRINT NAME	RCE#	PROJECT ENGINEER	
DESCRIPTION	BY	APPROVED	DATE
ORIGINAL	REC		

CCS27 COORDINATE

CCS83 COORDINATE

CONTRACTOR \_\_\_\_\_ DATE STARTED \_\_\_\_\_  
INSPECTOR \_\_\_\_\_ DATE COMPLETED \_\_\_\_\_

**PRELIMINARY**  
NOT FOR CONSTRUCTION

FILE NAME: C:\SA\10278 - Mission Bay PER\CA00146 Seawall\1\_Active\Design\03 STRUCTURAL\10278-F0-S-1.dwg  
PLOTTER: Tuesday, October 11, 2022 - 5:17pm USER: aburro

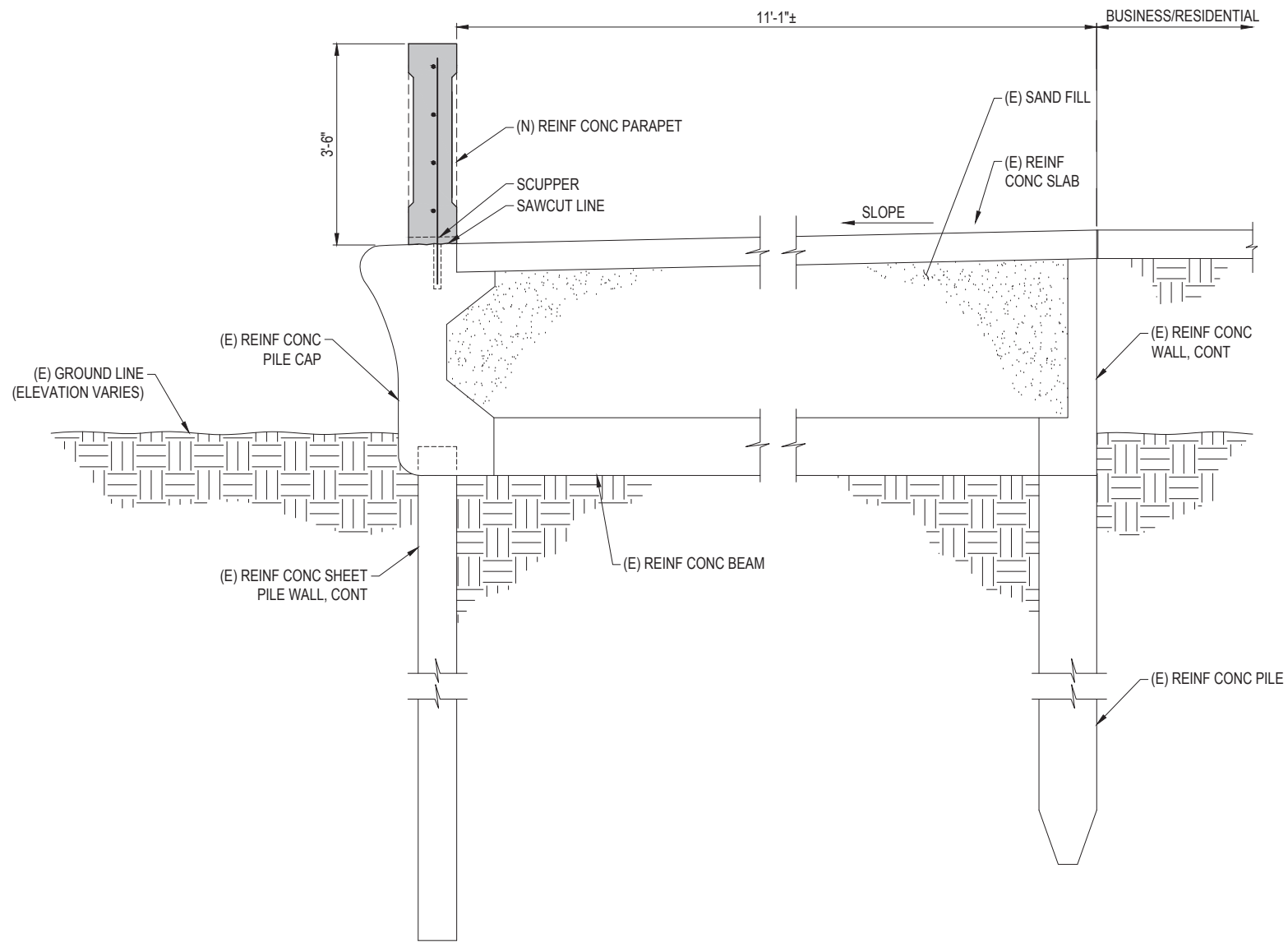

**SEGMENT A - OPTION 1: PARAPET REPLACEMENT**

SCALE: 3/4" = 1'-0"

STA 1+00.00 TO STA 19+85.00

STA 100+00.00 TO STA 167+73.33

C-1 TO C-6

A1

S-2

MISSION BEACH SEAWAL  
IMPROVEMENTS FEASIBILITY STUDY  
SEGMENT A  
OPTION 1: PARAPET REPLACEMENT

CITY OF SAN DIEGO, CALIFORNIA  
PUBLIC WORKS DEPARTMENT  
SHEET OF SHEETS

APPROVED:		DATE			SUBMITTED BY:	
FOR CITY ENGINEER					PROJECT MANAGER	
PRINT NAME		RCE#			CHECKED BY:	
DESCRIPTION		BY	APPROVED	DATE	FILMED	PROJECT ENGINEER
ORIGINAL		REC				CCS27 COORDINATE
						CCS83 COORDINATE

PRELIMINARY  
NOT FOR CONSTRUCTION

CONTRACTOR \_\_\_\_\_ DATE STARTED \_\_\_\_\_  
INSPECTOR \_\_\_\_\_ DATE COMPLETED \_\_\_\_\_

FILE NAME: C:\SA\10278 - Mission Bay PFR\CADD\MB Seawall\Design\03 STRUCTURAL\10278-FIG-S-2.dwg  
PLOTTER: Tandy, October 11, 2022 - 5:18pm USER: aburaw

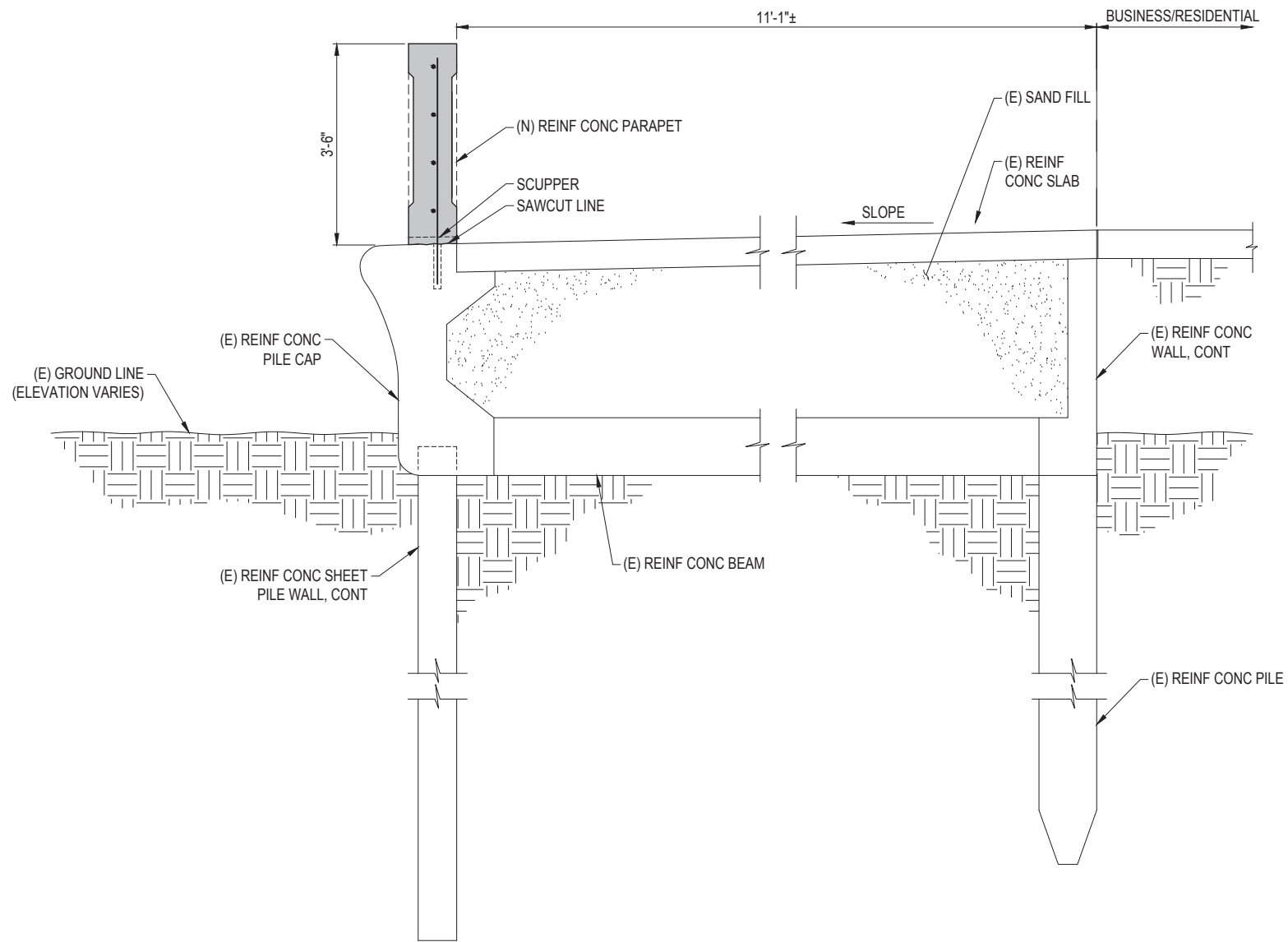

**SEGMENT A - OPTION 1: PARAPET REPLACEMENT**

SCALE: 3/4" = 1'-0"

STA 1+00.00 TO STA 19+85.00

STA 100+00.00 TO STA 167+73.33

C-1 TO C-6

A1

S-2

MISSION BEACH SEAWALL  
IMPROVEMENTS FEASIBILITY STUDY  
SEGMENT A  
OPTION 1: PARAPET REPLACEMENT

CITY OF SAN DIEGO, CALIFORNIA  
PUBLIC WORKS DEPARTMENT  
SHEET OF SHEETS

APPROVED:		DATE		SUBMITTED BY:	
FOR CITY ENGINEER				PROJECT MANAGER	
PRINT NAME		RCE#		CHECKED BY:	
DESCRIPTION	BY	APPROVED	DATE	FILMED	PROJECT ENGINEER
ORIGINAL	REC				CCS27 COORDINATE
					CCS83 COORDINATE

PRELIMINARY  
NOT FOR CONSTRUCTION

CONTRACTOR \_\_\_\_\_ DATE STARTED \_\_\_\_\_  
INSPECTOR \_\_\_\_\_ DATE COMPLETED \_\_\_\_\_

FILE NAME: C:\SA\10278 - Mission Bay PFR\CADD\MB Seawall\Design\03 STRUCTURAL\10278-FG-S-2.dwg  
PLOTTER: Tandy, October 11, 2022 - 5:18pm USER: aburaw

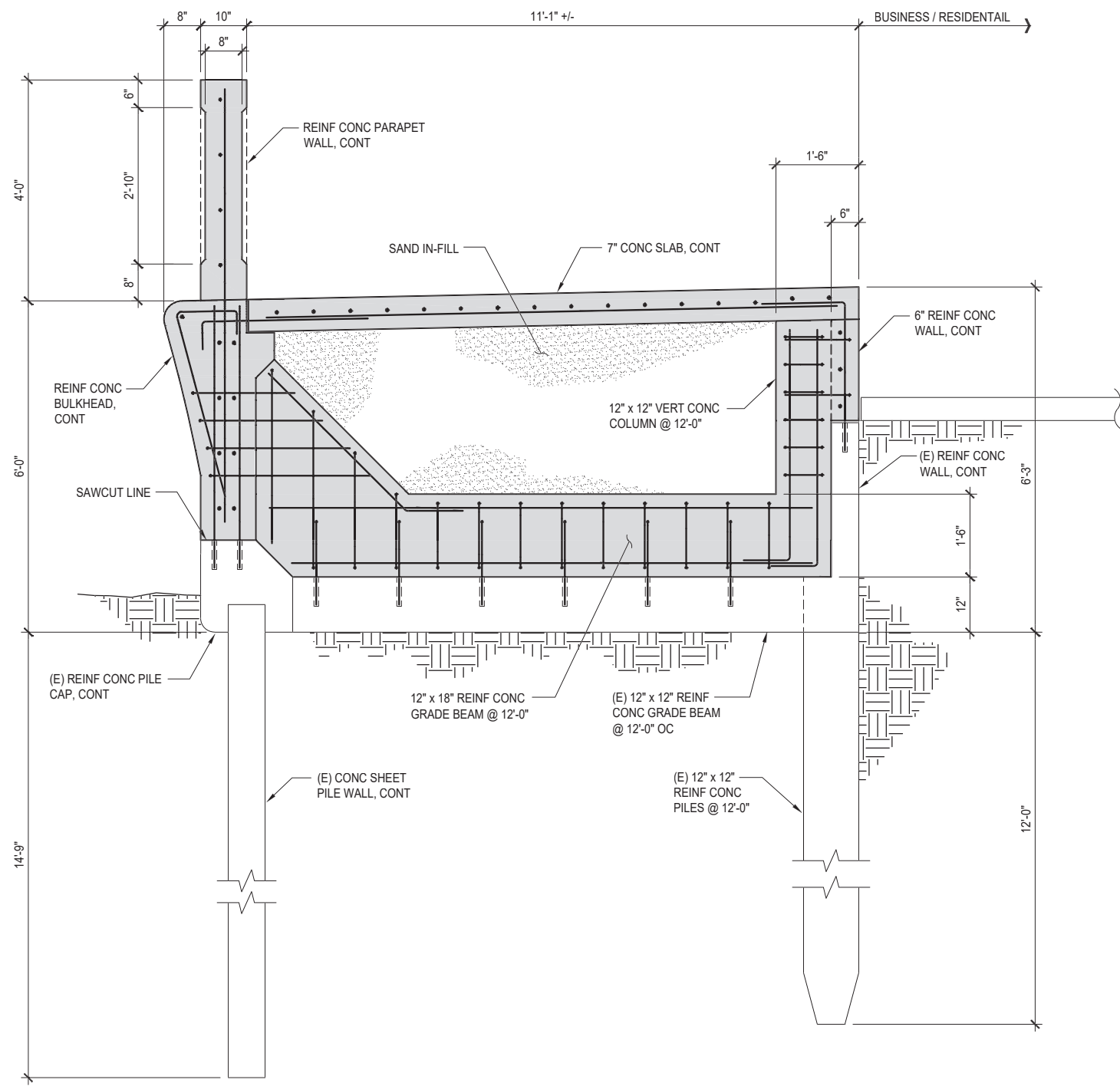

**SEGMENT A - OPTION 2: RAISED BOARDWALK**  
 3/4" = 1'-0"  
 STA 1+00.00 TO STA 19+85.00  
 STA 100+00.00 TO STA 167.73.33



PRELIMINARY  
 NOT FOR CONSTRUCTION

S-3

MISSION BEACH SEAWALL  
 IMPROVEMENTS FEASIBILITY STUDY  
 SEGMENT A  
 OPTION 2: RAISED BOARDWALK

CITY OF SAN DIEGO, CALIFORNIA  
 PUBLIC WORKS DEPARTMENT  
 SHEET OF SHEETS

APPROVED:	DATE	FOR CITY ENGINEER	DATE
PRINT NAME	RCE#	PROJECT MANAGER	CHECKED BY:
DESCRIPTION	BY	APPROVED	DATE
ORIGINAL	REC		

CONTRACTOR \_\_\_\_\_ DATE STARTED \_\_\_\_\_  
 INSPECTOR \_\_\_\_\_ DATE COMPLETED \_\_\_\_\_

FILE NAME: J:\yada\proj\10707600 MISSION BAY PARK EIR\dwg\3 - 3.dwg  
 PLOTTED: Monday, November 07, 2022 - 10:34am USER: roud

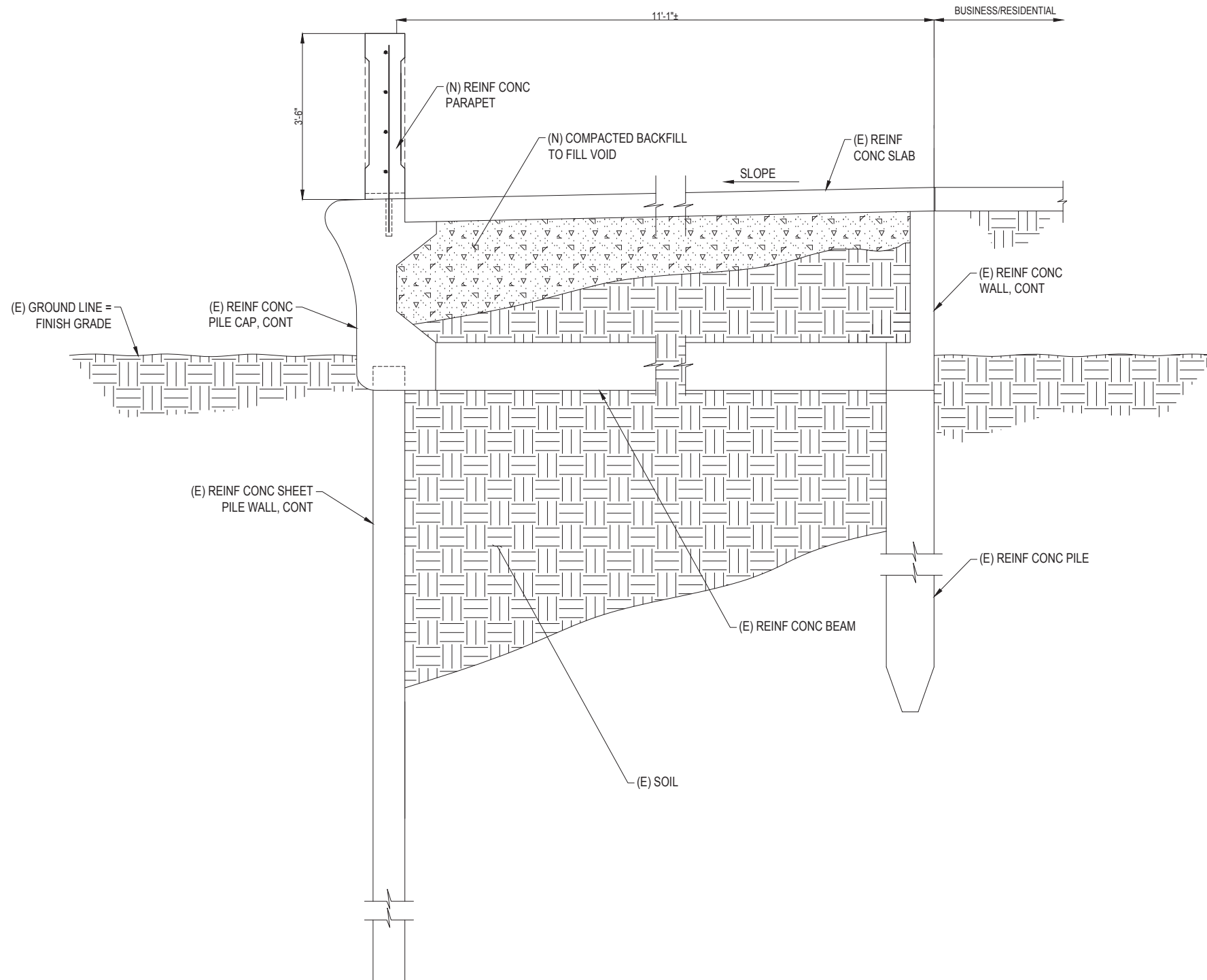

**SEGMENT A - TYPICAL VOID REPAIR**

SCALE: 3/4" = 1'-0"

STA 128+40.00 TO STA 168+30.00

C-1 TO C-6

**A1**

**PRELIMINARY**  
NOT FOR CONSTRUCTION

**S-4**

**MISSION BEACH SEAWALL  
IMPROVEMENTS FEASIBILITY STUDY  
SEGMENT A  
TYPICAL VOID REPAIR**

CITY OF SAN DIEGO, CALIFORNIA  
PUBLIC WORKS DEPARTMENT  
SHEET OF SHEETS

APPROVED:		DATE		SUBMITTED BY:	
FOR CITY ENGINEER				PROJECT MANAGER	
PRINT NAME		RCE#		CHECKED BY:	
DESCRIPTION	BY	APPROVED	DATE	FILMED	PROJECT ENGINEER
ORIGINAL	REC				CCS27 COORDINATE
					CCS83 COORDINATE

CONTRACTOR \_\_\_\_\_ DATE STARTED \_\_\_\_\_  
INSPECTOR \_\_\_\_\_ DATE COMPLETED \_\_\_\_\_

FILE NAME: C:\SDA\10278 - Mission Bay PWR\CADD\MB Seawall\1\_Active\Design\03\_STRUCTURAL\10278-Fig-S-4.dwg  
 PLOTTED: Tuesday, October 11, 2022 - 5:18pm USER: aburaw

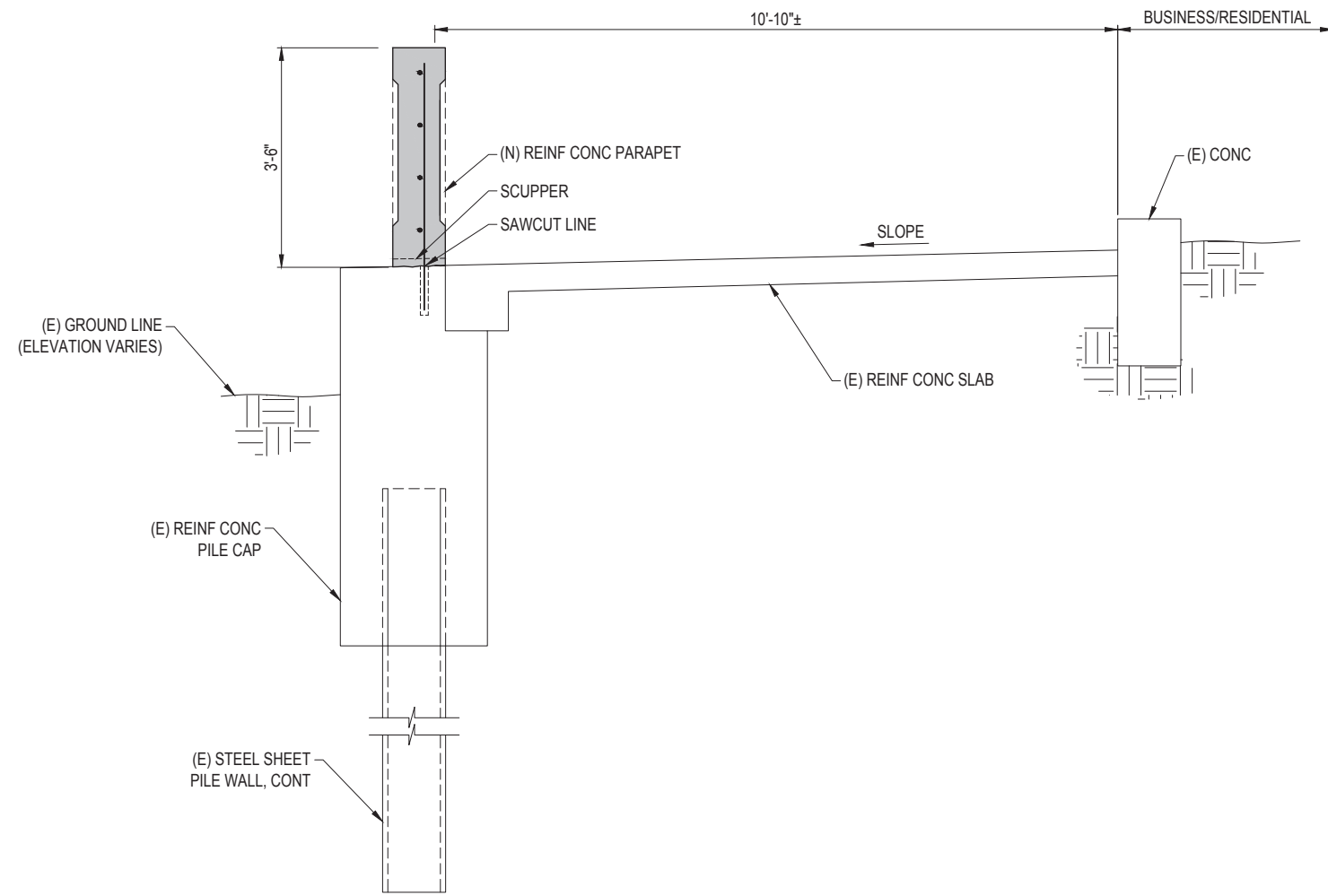

**SEGMENT B - PARAPET REPLACEMENT**

SCALE: 3/4" = 1'-0"

STA 167+73.33 TO STA 177+92.56

C-1 **B1**

**S-5**

**MISSION BEACH SEAWALL  
IMPROVEMENTS FEASIBILITY STUDY  
SEGMENT B  
PARAPET REPLACEMENT**

CITY OF SAN DIEGO, CALIFORNIA  
PUBLIC WORKS DEPARTMENT  
SHEET OF SHEETS

APPROVED:					SUBMITTED BY:	
FOR CITY ENGINEER _____ DATE _____					PROJECT MANAGER _____	
PRINT NAME _____ RCE# _____					CHECKED BY:	
DESCRIPTION	BY	APPROVED	DATE	FILMED	PROJECT ENGINEER _____	
ORIGINAL	REC				CCS27 COORDINATE _____	
					CCS83 COORDINATE _____	

**PRELIMINARY**  
NOT FOR CONSTRUCTION

CONTRACTOR \_\_\_\_\_ DATE STARTED \_\_\_\_\_  
INSPECTOR \_\_\_\_\_ DATE COMPLETED \_\_\_\_\_

FILE NAME: C:\SDA\10278 - Mission Bay FFR\CADD\MB Seawall\Drawings\Design\03 STRUCTURAL\10278-FIG-S-5.dwg  
PLOTTER: Tuesday, October 11, 2022 - 5:18pm USER: aburrow

FILE NAME: C:\SDA\10278 - Mission Bay PER\1001\MB Seawall\1\_Active\Design\03 STRUCTURAL\10278-Fig-S-6.dwg  
 PLOTTED: Tuesday, October 11, 2022 - 5:18pm USER: aburrow

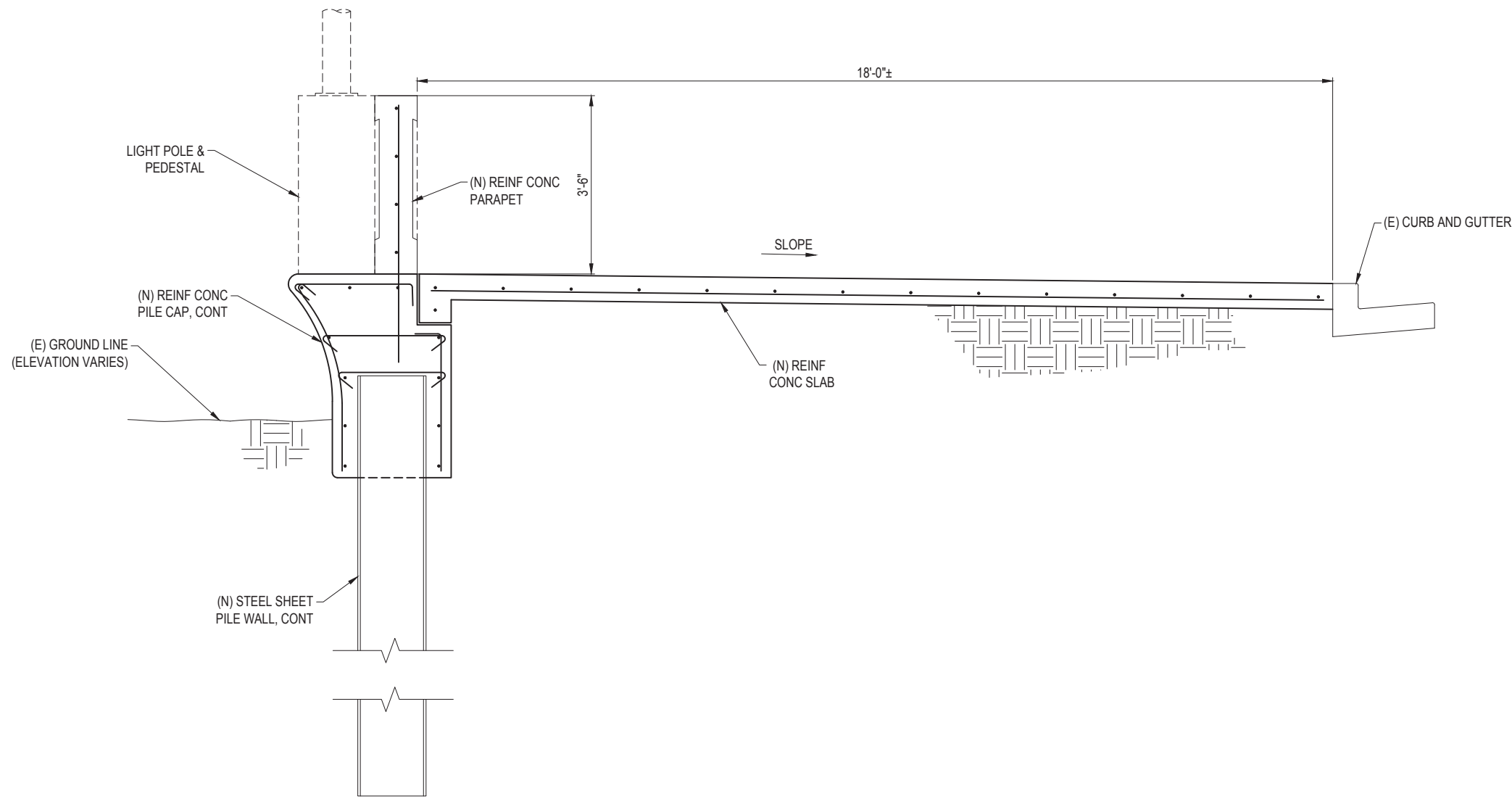

**SEGMENT C - OPTION 1: SEAWALL**

SCALE: 3/4" = 1'-0"

STA 178+03.83 TO STA 181+71.00

C-1

**B1**

**PRELIMINARY**  
NOT FOR CONSTRUCTION

**S - 6**

**MISSION BEACH SEAWALL  
 IMPROVEMENTS FEASIBILITY STUDY  
 SEGMENT C  
 OPTION 1: SEAWALL**

CITY OF SAN DIEGO, CALIFORNIA  
 PUBLIC WORKS DEPARTMENT  
 SHEET OF SHEETS

APPROVED:		DATE		SUBMITTED BY:	
FOR CITY ENGINEER				PROJECT MANAGER	
PRINT NAME		RCE#		CHECKED BY:	
DESCRIPTION	BY	APPROVED	DATE	FILMED	PROJECT ENGINEER
ORIGINAL	REC				CCS27 COORDINATE
					CCS83 COORDINATE

CONTRACTOR \_\_\_\_\_ DATE STARTED \_\_\_\_\_  
 INSPECTOR \_\_\_\_\_ DATE COMPLETED \_\_\_\_\_

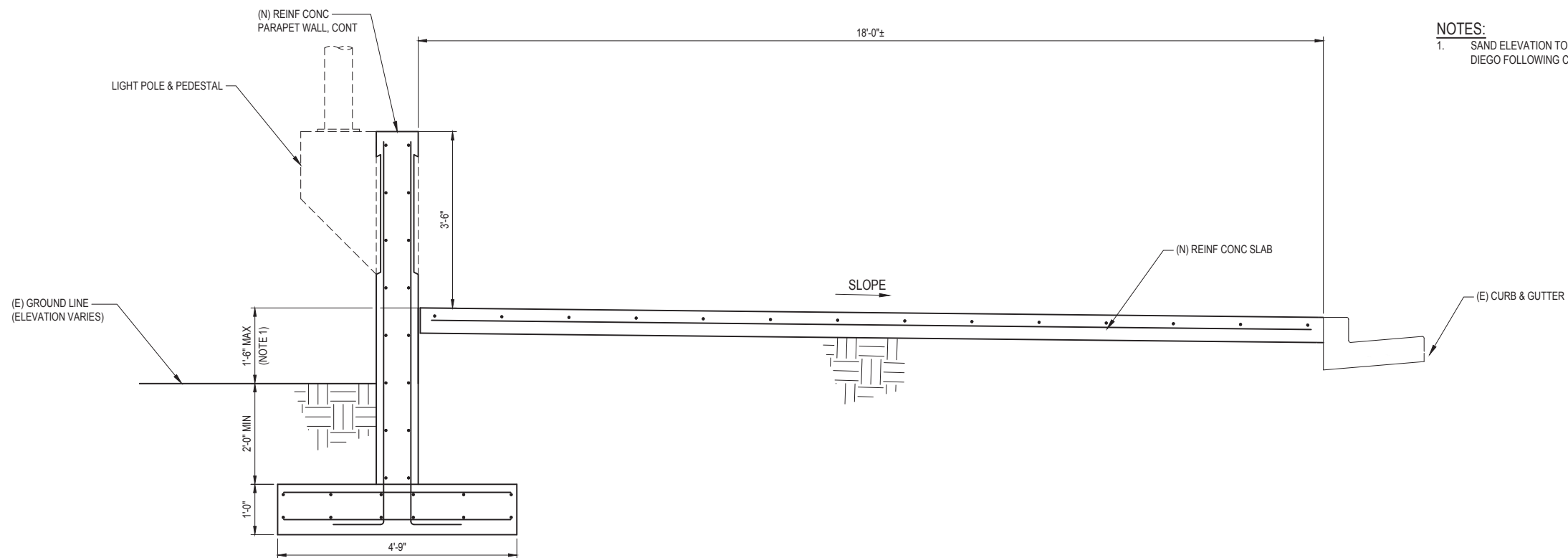

**NOTES:**  
 1. SAND ELEVATION TO BE MAINTAINED BY CITY OF SAN DIEGO FOLLOWING CLOSEOUT OF CONSTRUCTION

**SEGMENT C - OPTION 2: DECORATIVE WALL**  
 SCALE: 3/4" = 1'-0" STA 178+03.83 TO STA 181+71.00

C-1 **C1**

**S-7**

MISSION BEACH SEAWALL  
 IMPROVEMENTS FEASIBILITY STUDY  
 SEGMENT C  
 OPTION 2: DECORATIVE WALL

CITY OF SAN DIEGO, CALIFORNIA  
 PUBLIC WORKS DEPARTMENT  
 SHEET OF SHEETS

APPROVED:		DATE		SUBMITTED BY:	
FOR CITY ENGINEER				PROJECT MANAGER	
PRINT NAME		RCE#		CHECKED BY:	
DESCRIPTION	BY	APPROVED	DATE	FILMED	PROJECT ENGINEER
ORIGINAL	REC				CCS27 COORDINATE
					CCS83 COORDINATE

**PRELIMINARY**  
 NOT FOR CONSTRUCTION

CONTRACTOR \_\_\_\_\_ DATE STARTED \_\_\_\_\_  
 INSPECTOR \_\_\_\_\_ DATE COMPLETED \_\_\_\_\_

FILE NAME: C:\SDA\10278 - Mission Bay PWR\1001\MB Seawall\1\_Active\Design\03 STRUCTURAL\10278-FIG-S-7.dwg  
 PLOTTED: Tuesday, October 11, 2022 - 5:18pm USER: aburaw



FILE NAME: Q:\SA\10278 - Mission Bay FEIR\AD\MB Seawall\Design\03 STRUCTURAL\10278-FIG-S-9.dwg  
 PLOTTED: Wednesday, October 12, 2022 - 10:20am USER: dburrow

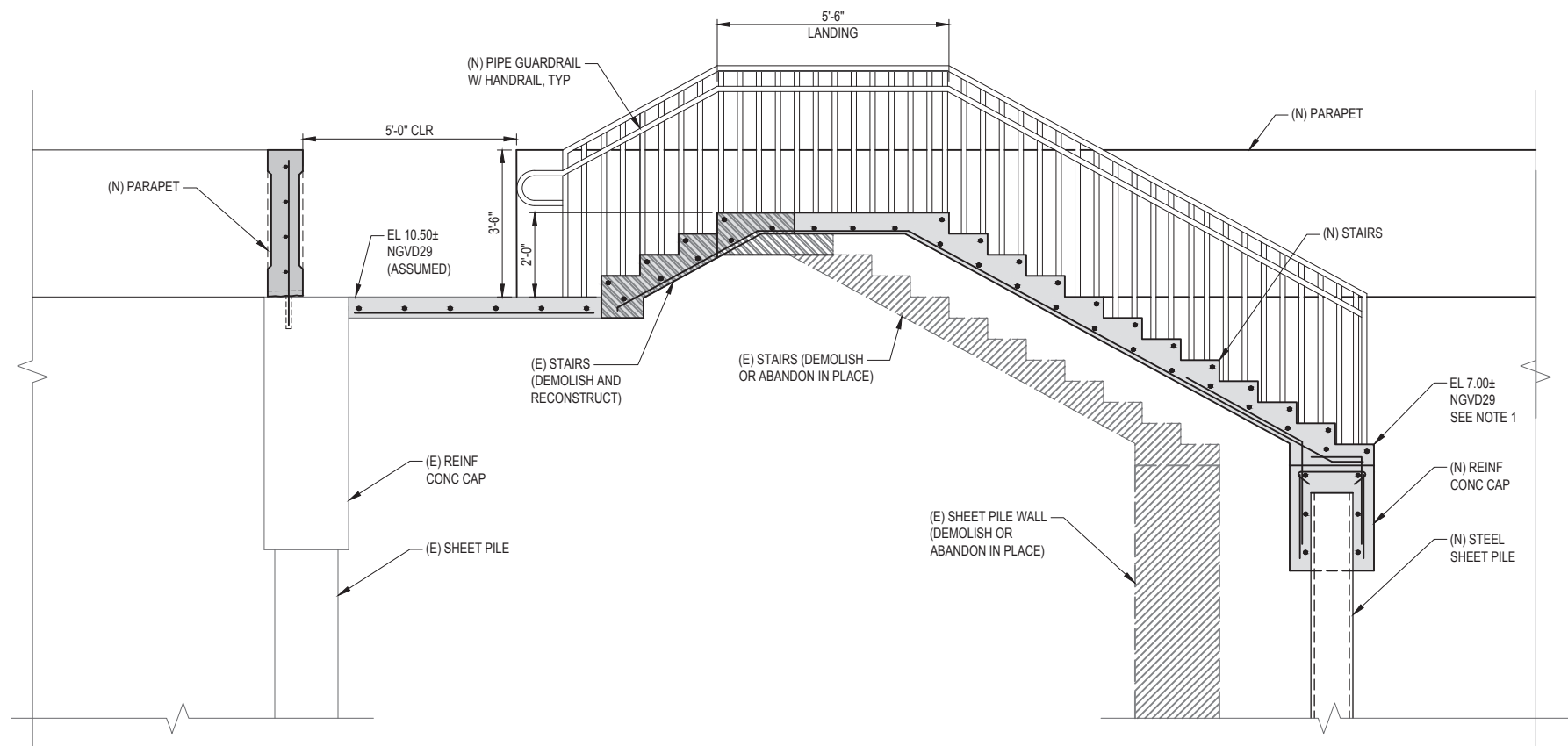

**SECTION - STAIRS**

SCALE: 1/2" = 1'-0"

C1

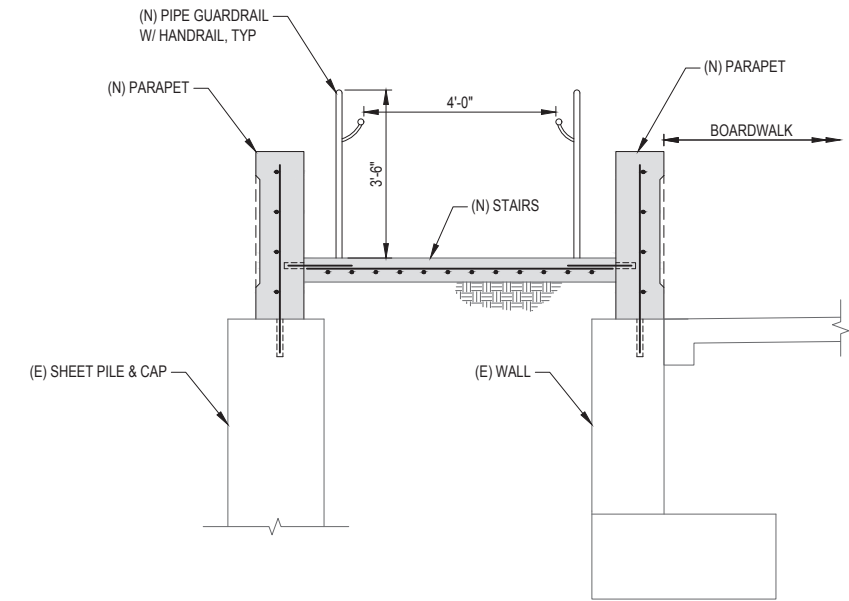

**SECTION**

SCALE: 1/2" = 1'-0"

C3

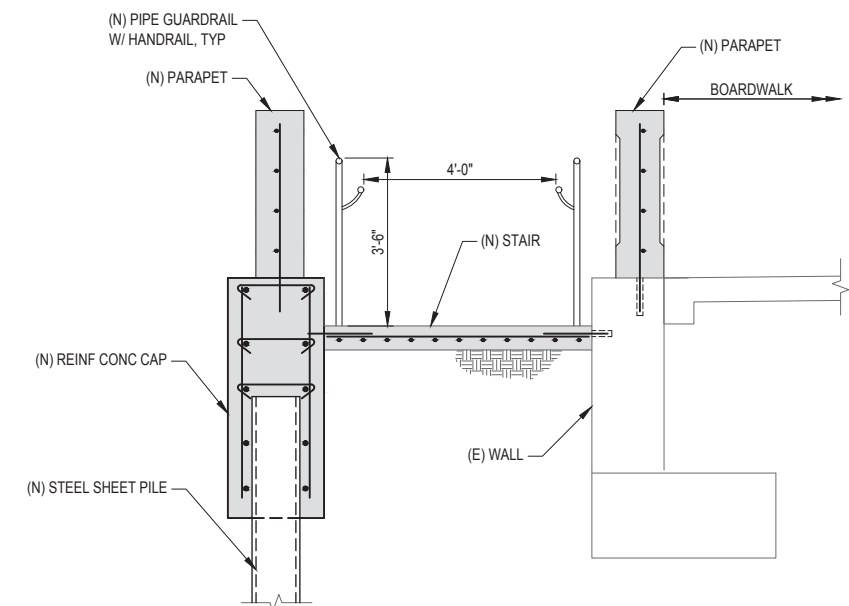

**SECTION**

SCALE: 1/2" = 1'-0"

A3

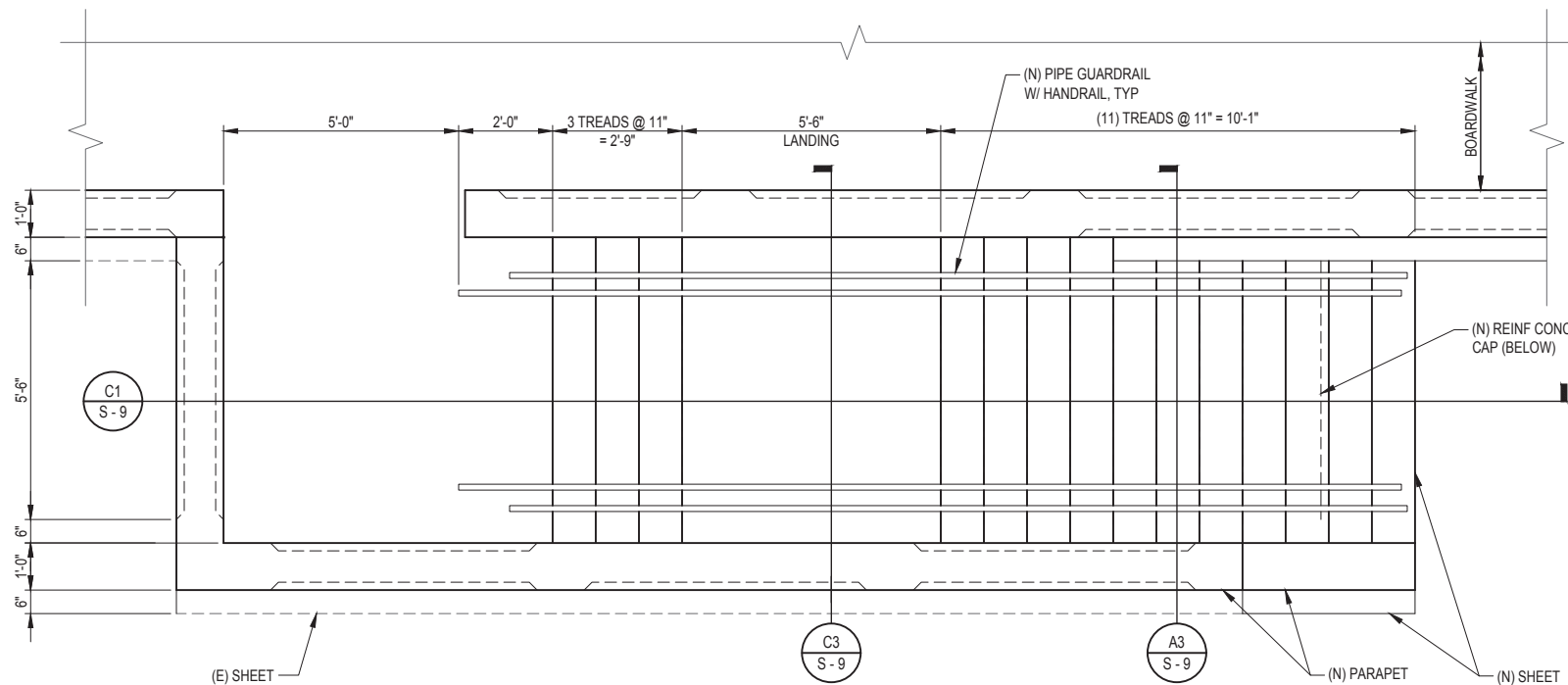

**BEACH ACCESS STAIR PLAN**

SCALE: 1/2" = 1'-0"

A1

**NOTES:**

- CITY OF SAN DIEGO TO MAINTAIN SAND ELEVATION AT OR ABOVE BOTTOM OF STAIRS FOLLOWING CLOSEOUT OF CONSTRUCTION.

**PRELIMINARY**  
NOT FOR CONSTRUCTION

S-9

**MISSION BEACH SEAWALL IMPROVEMENTS FEASIBILITY STUDY**

**TYPICAL BEACH ACCESS STAIR**

CITY OF SAN DIEGO, CALIFORNIA  
PUBLIC WORKS DEPARTMENT  
SHEET OF SHEETS

APPROVED:		DATE		SUBMITTED BY:	
FOR CITY ENGINEER		DATE		PROJECT MANAGER	
PRINT NAME		RCE#		CHECKED BY:	
DESCRIPTION	BY	APPROVED	DATE	FILMED	PROJECT ENGINEER
ORIGINAL	REC				CCS27 COORDINATE
					CCS83 COORDINATE
CONTRACTOR			DATE STARTED		
INSPECTOR			DATE COMPLETED		

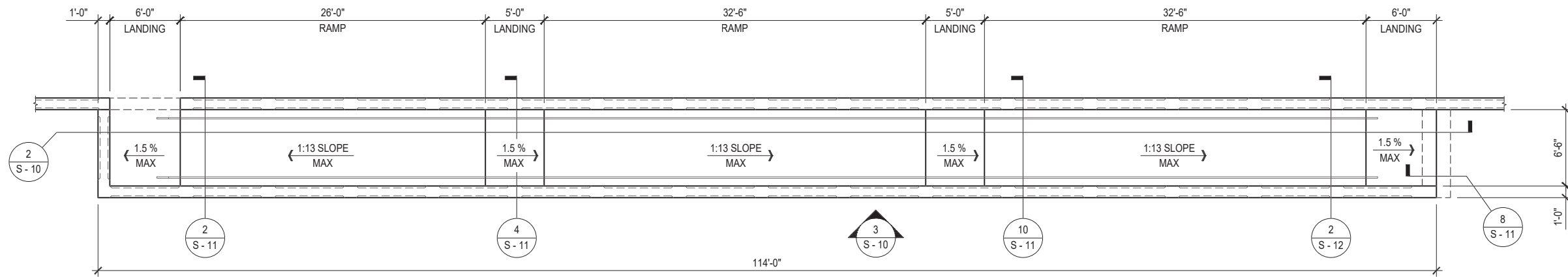

**BEACH ACCESS - RAMP PLAN**

3/16" = 1'-0"

1

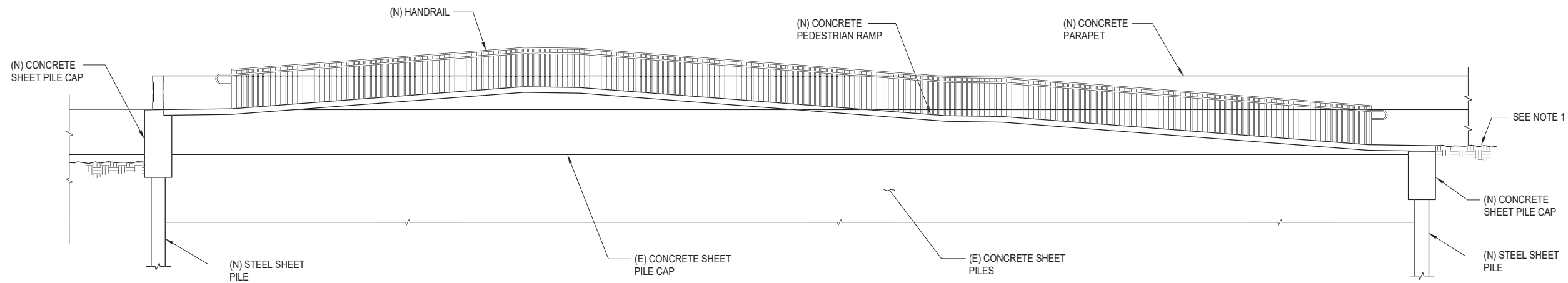

- NOTES:**
- CITY OF SAN DIEGO TO MAINTAIN SAND ELEVATION AT OR ABOVE BOTTOM OF RAMP FOLLOWING CLOSURE OF CONSTRUCTION

**BEACH ACCESS - SECTION RAMP**

3/16" = 1'-0"

2

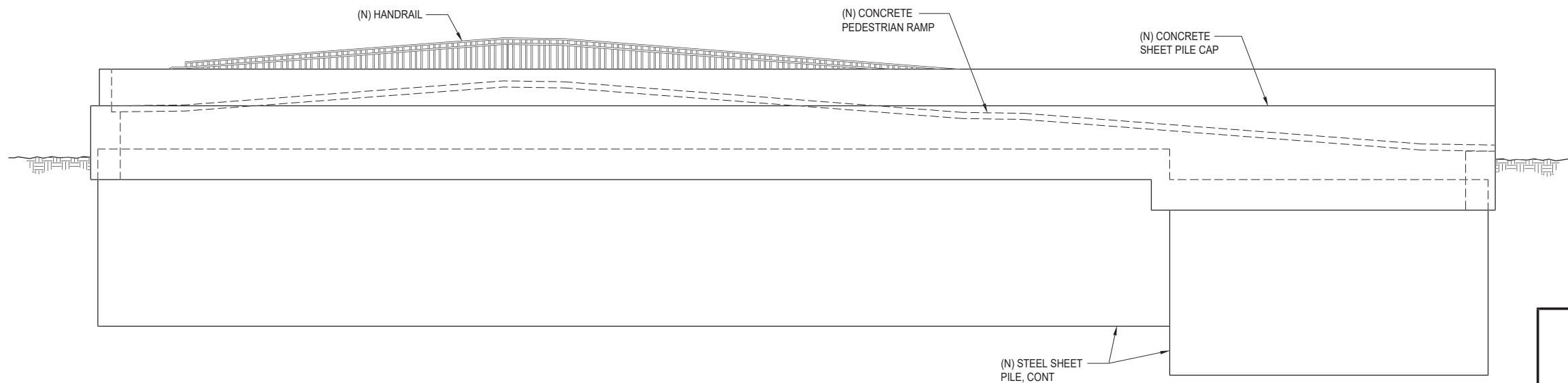

**BEACH ACCESS - WEST ELEVATION RAMP**

3/16" = 1'-0"

3



388 CAMINO DEL RIO NORTH STE. NO. 110  
SAN DIEGO, CA. 92108  
619.297.2223 • FAX 619.297.4913  
www.sdse.com

PRELIMINARY  
NOT FOR CONSTRUCTION

S - 10

**MISSION BEACH SEAWALL IMPROVEMENTS FEASIBILITY STUDY  
TYPICAL BEACH ACCESS RAMP LAYOUT**

CITY OF SAN DIEGO, CALIFORNIA  
PUBLIC WORKS DEPARTMENT  
SHEET OF SHEETS

APPROVED:	DATE	FOR CITY ENGINEER	DATE	PROJECT MANAGER
PRINT NAME	RCE#	CHECKED BY:	PROJECT ENGINEER	
DESCRIPTION	BY	APPROVED	DATE	FILMED
ORIGINAL	REC			
CONTRACTOR	INSPECTOR	DATE STARTED	DATE COMPLETED	

FILE NAME: J:\yada\proj\10707600\_MMISSION BEACH SEAWALL IMPROVEMENTS FEASIBILITY STUDY\10.dwg  
 PLOTTED: Monday, November 07, 2022 - 10:35am USER: roud

FOR ITEMS NOT NOTED, SEE  $\frac{2}{S-11}$

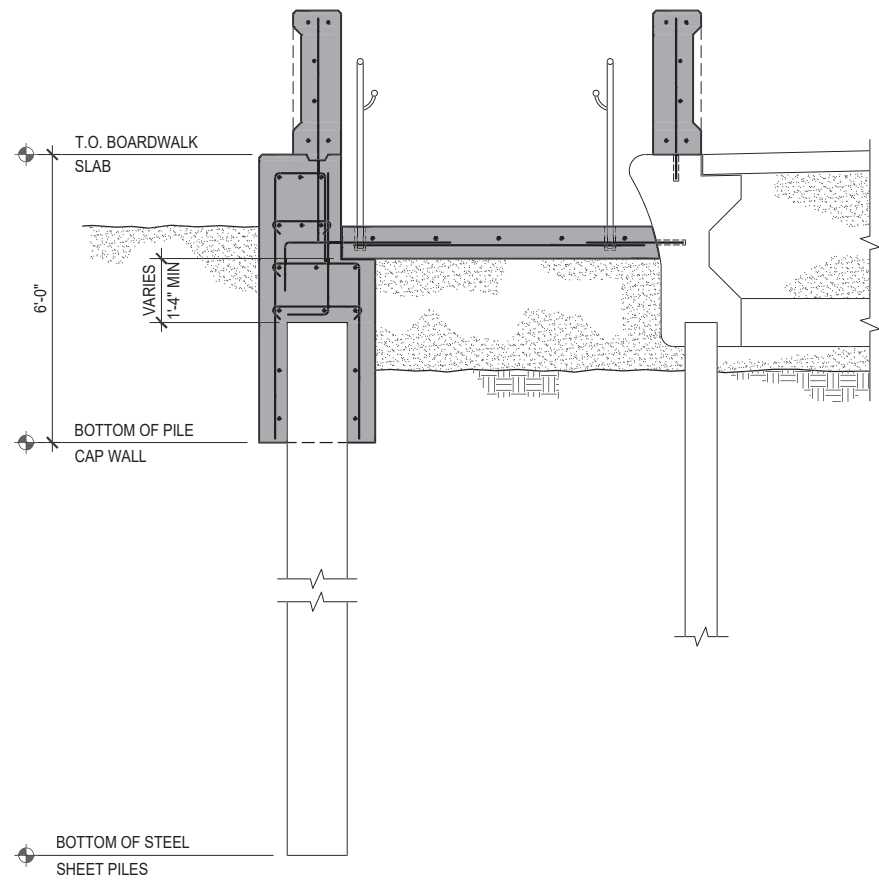

**RAMP SECTION**  
1/2" = 1'-0"

10

FOR ITEMS NOT NOTED, SEE  $\frac{2}{S-11}$

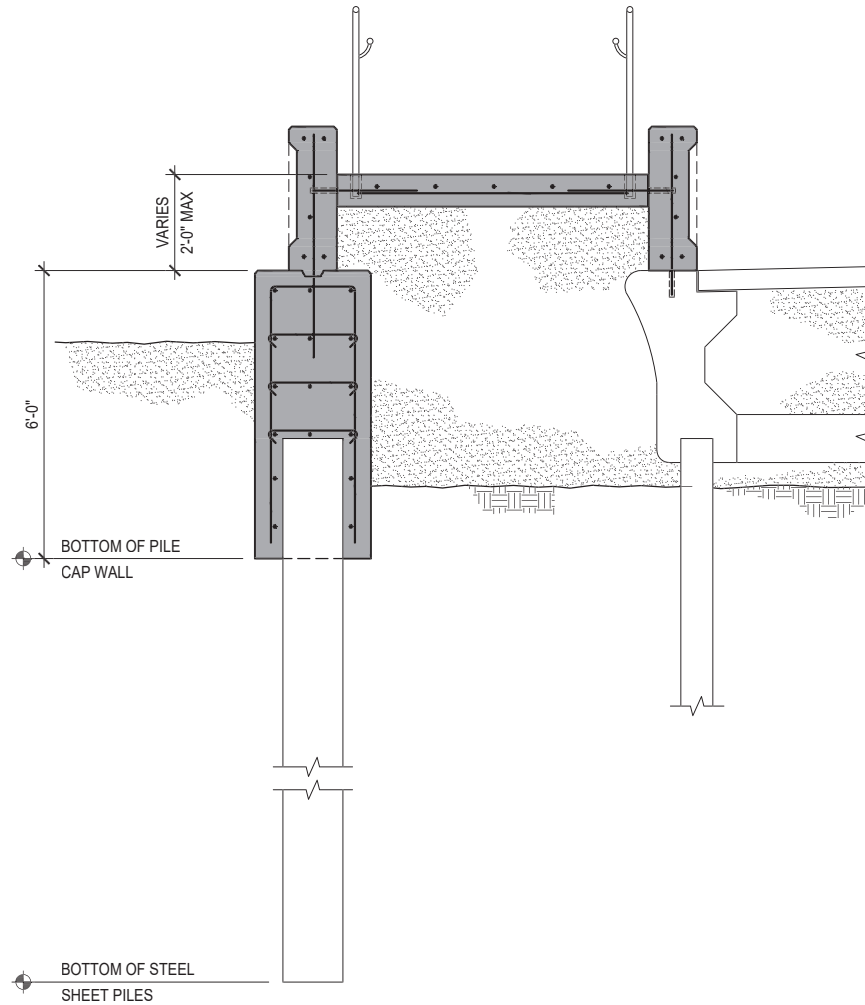

**RAMP SECTION**  
1/2" = 1'-0"

4

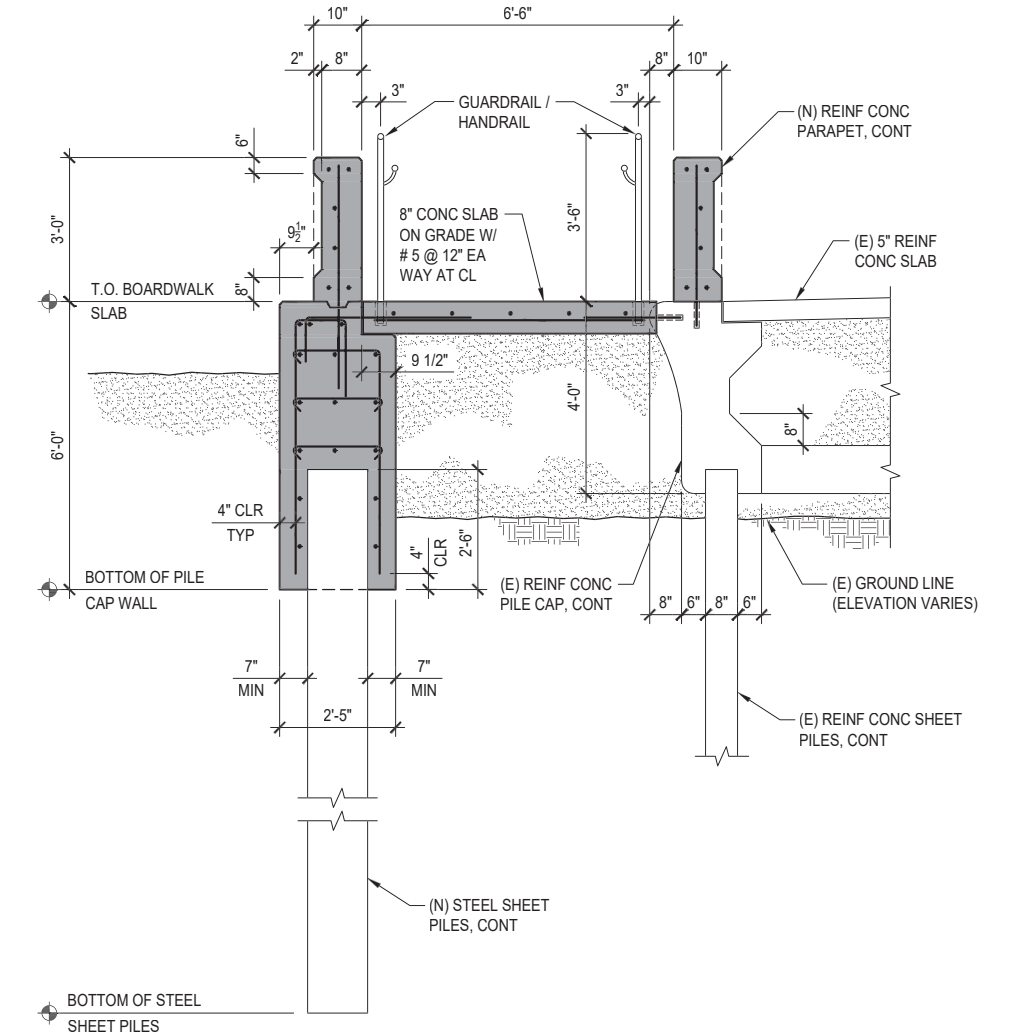

**RAMP SECTION**  
1/2" = 1'-0"

2

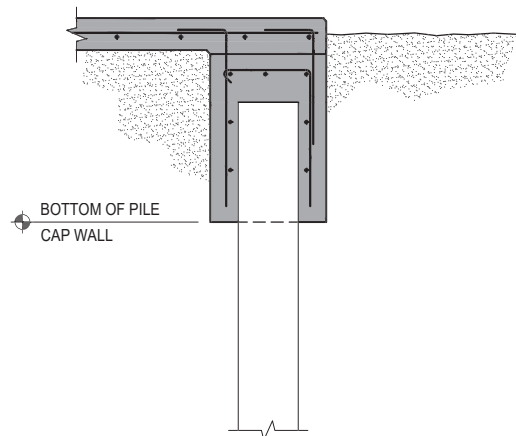

**DETAIL**  
1/2" = 1'-0"

8



PRELIMINARY  
NOT FOR CONSTRUCTION

S - 11

MISSION BEACH SEAWALL IMPROVEMENTS FEASIBILITY STUDY  
TYPICAL BEACH ACCESS RAMP  
DETAILS NO.1

CITY OF SAN DIEGO, CALIFORNIA  
PUBLIC WORKS DEPARTMENT  
SHEET OF SHEETS

APPROVED:	DATE	FOR CITY ENGINEER	PROJECT MANAGER	
PRINT NAME	RCE#	CHECKED BY:	PROJECT ENGINEER	
DESCRIPTION	BY	APPROVED	DATE	FILMED
ORIGINAL	REC			

CONTRACTOR \_\_\_\_\_ DATE STARTED \_\_\_\_\_  
INSPECTOR \_\_\_\_\_ DATE COMPLETED \_\_\_\_\_

FILE NAME: J:\yada\proj\17075000 MISSION BEACH PARK IMPROVEMENTS\11.dwg  
PLOTTER: Monby, November 07, 2022 - 10:56am USER: roud

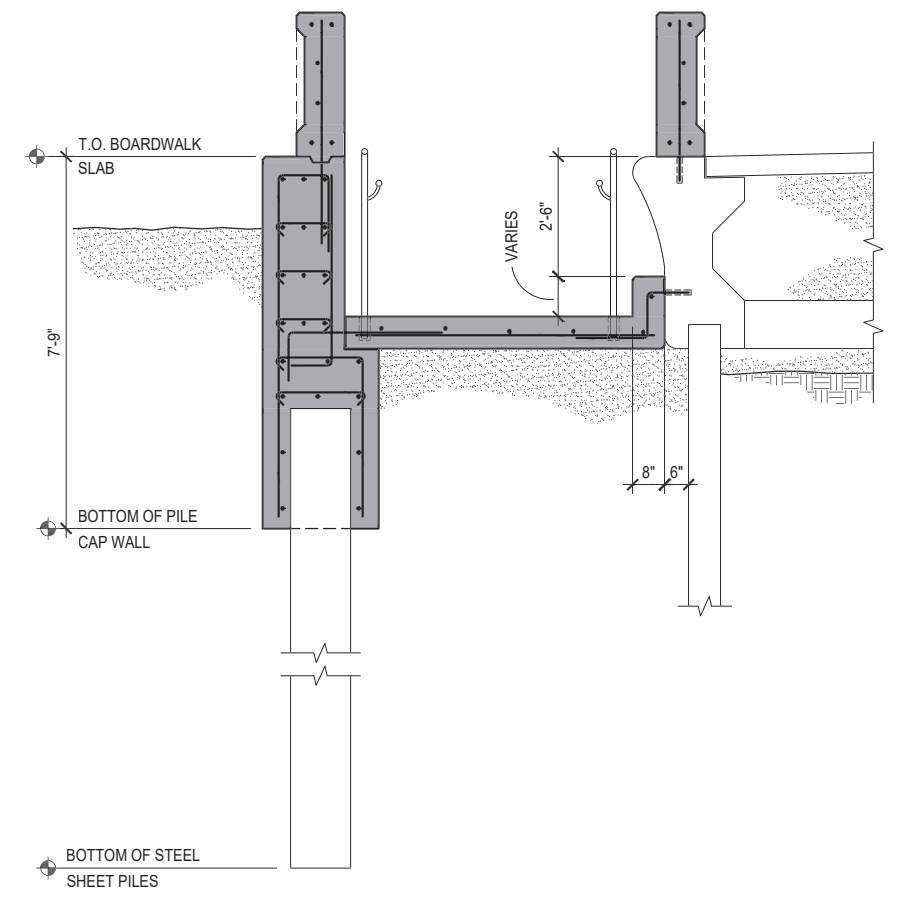

**RAMP SECTION**  
1/2" = 1'-0"



PRELIMINARY  
NOT FOR CONSTRUCTION

S - 12

MISSION BEACH SEAWALL IMPROVEMENTS FEASIBILITY STUDY  
TYPICAL BEACH ACCESS RAMP  
DETAILS NO.2

CITY OF SAN DIEGO, CALIFORNIA  
PUBLIC WORKS DEPARTMENT  
SHEET OF SHEETS

APPROVED:	DATE	FOR CITY ENGINEER	DATE
PRINT NAME	RCE#	PROJECT MANAGER	CHECKED BY:
DESCRIPTION	BY	APPROVED	DATE
ORIGINAL	REC		

CONTRACTOR \_\_\_\_\_ DATE STARTED \_\_\_\_\_  
INSPECTOR \_\_\_\_\_ DATE COMPLETED \_\_\_\_\_



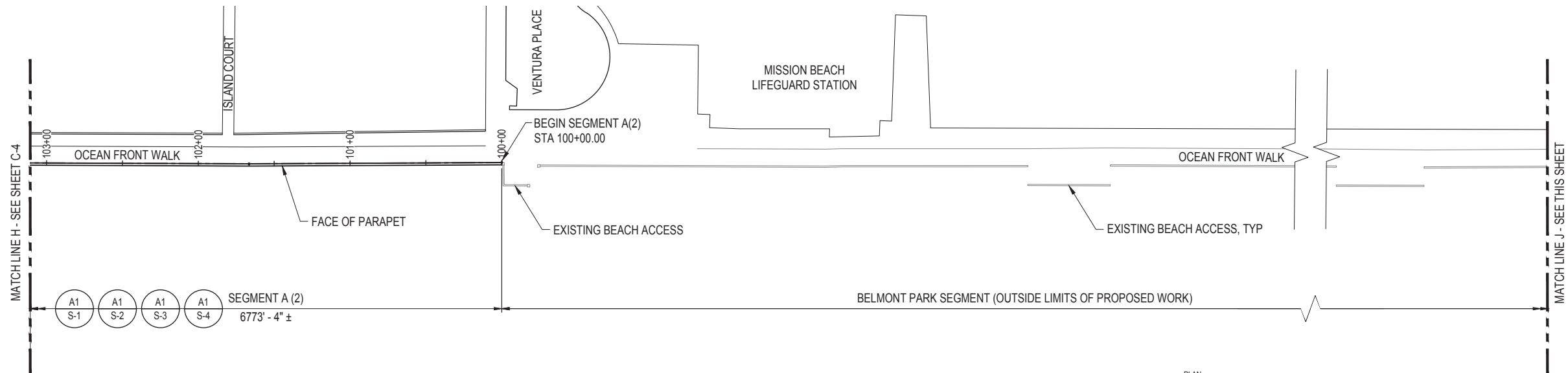

**C1** PLAN - MISSION BEACH BOARDWALK  
SCALE: NTS

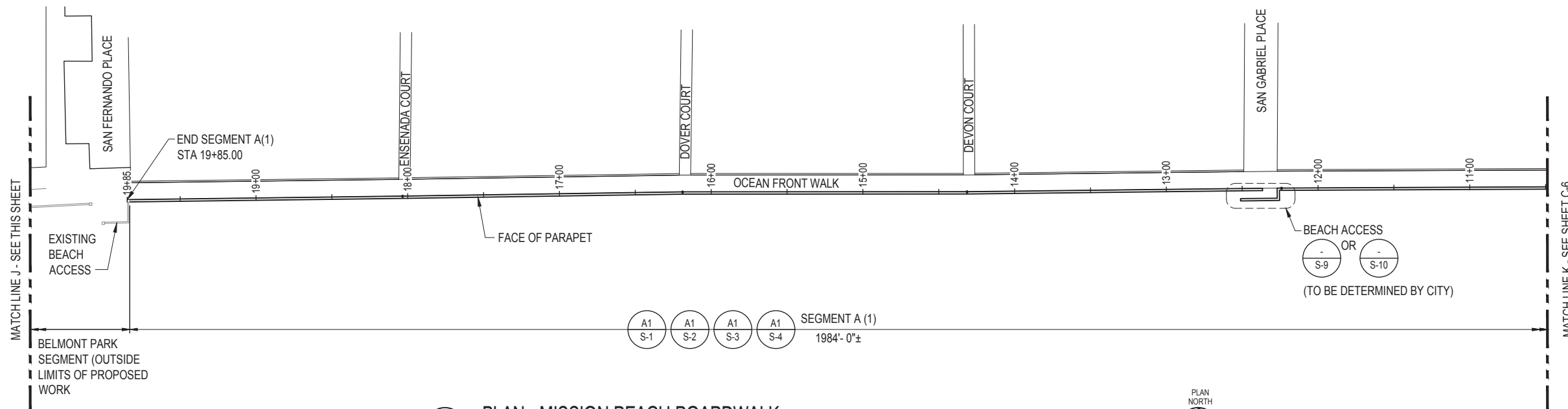

**A1** PLAN - MISSION BEACH BOARDWALK  
SCALE: NTS

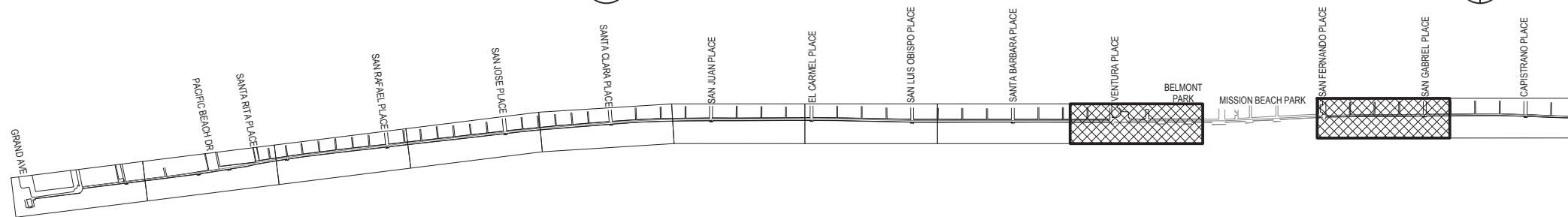

**OVERALL KEY PLAN**  
NOT TO SCALE

**PRELIMINARY**  
NOT FOR CONSTRUCTION

**C-5**

**MISSION BEACH SEAWALL IMPROVEMENTS FEASIBILITY STUDY**

**PARTIAL PLAN - 5**

CITY OF SAN DIEGO, CALIFORNIA  
PUBLIC WORKS DEPARTMENT  
SHEET OF SHEETS

APPROVED:	FOR CITY ENGINEER	DATE	PROJECT MANAGER	
PRINT NAME	RCE#	CHECKED BY:	PROJECT ENGINEER	
DESCRIPTION	BY	APPROVED	DATE	FILMED
ORIGINAL	REC			

CONTRACTOR INSPECTOR \_\_\_\_\_ DATE STARTED \_\_\_\_\_ DATE COMPLETED \_\_\_\_\_

FILE NAME: C:\SDA\10278 - Mission Bay FERR\000\MB Seawall\Drawings\Design\02 CHL\10278-F5-05.dwg  
 PRINTED: Tuesday, October 11, 2022 - 5:17pm USER: aburru

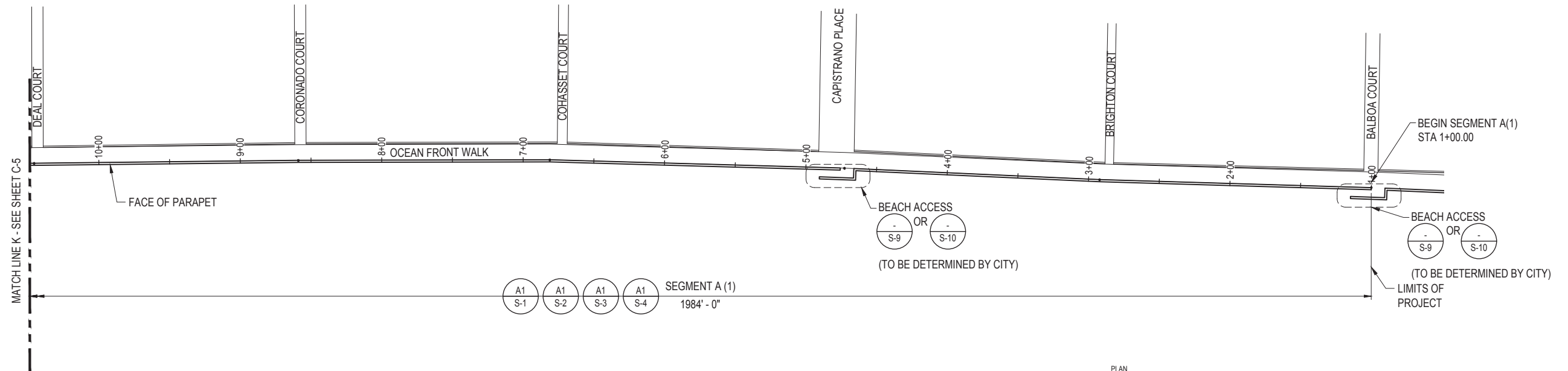

**C1** PLAN - MISSION BEACH BOARDWALK  
SCALE: NTS

PLAN NORTH

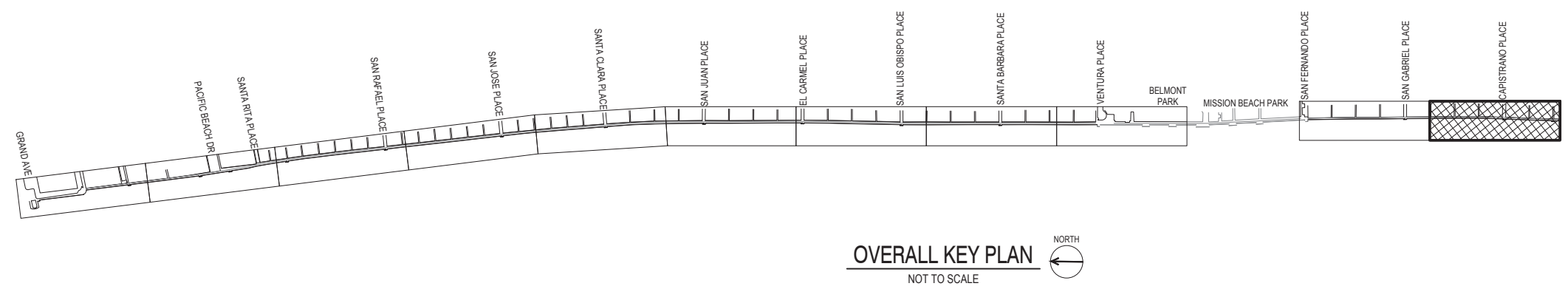

**PRELIMINARY**  
NOT FOR CONSTRUCTION

MISSION BEACH SEAWALL IMPROVEMENTS FEASIBILITY STUDY

PARTIAL PLAN - 6

CITY OF SAN DIEGO, CALIFORNIA  
PUBLIC WORKS DEPARTMENT  
SHEET OF SHEETS

APPROVED:	FOR CITY ENGINEER	DATE	WBS	
PRINT NAME	BY	APPROVED	DATE	FILMED
DESCRIPTION	REC	RCE#	DATE	FILMED
ORIGINAL				

CONTRACTOR INSPECTOR \_\_\_\_\_ DATE STARTED \_\_\_\_\_ DATE COMPLETED \_\_\_\_\_

FILE NAME: C:\SDA\10278 - Mission Bay FERR\000\MB Seawall\Drawings\Design\02 CHM\10278-F6-06.dwg  
 PLOTTED: Tuesday, October 11, 2022 - 5:17pm USER: aburrow

FILE NAME: G:\S\10278 - Mission Bay PER\100\MB Sewall\Design\02 Civil\10278-F6-C7.dwg  
 PRINTED: Monday, October 17, 2022 - 10:48am USER: aburrow

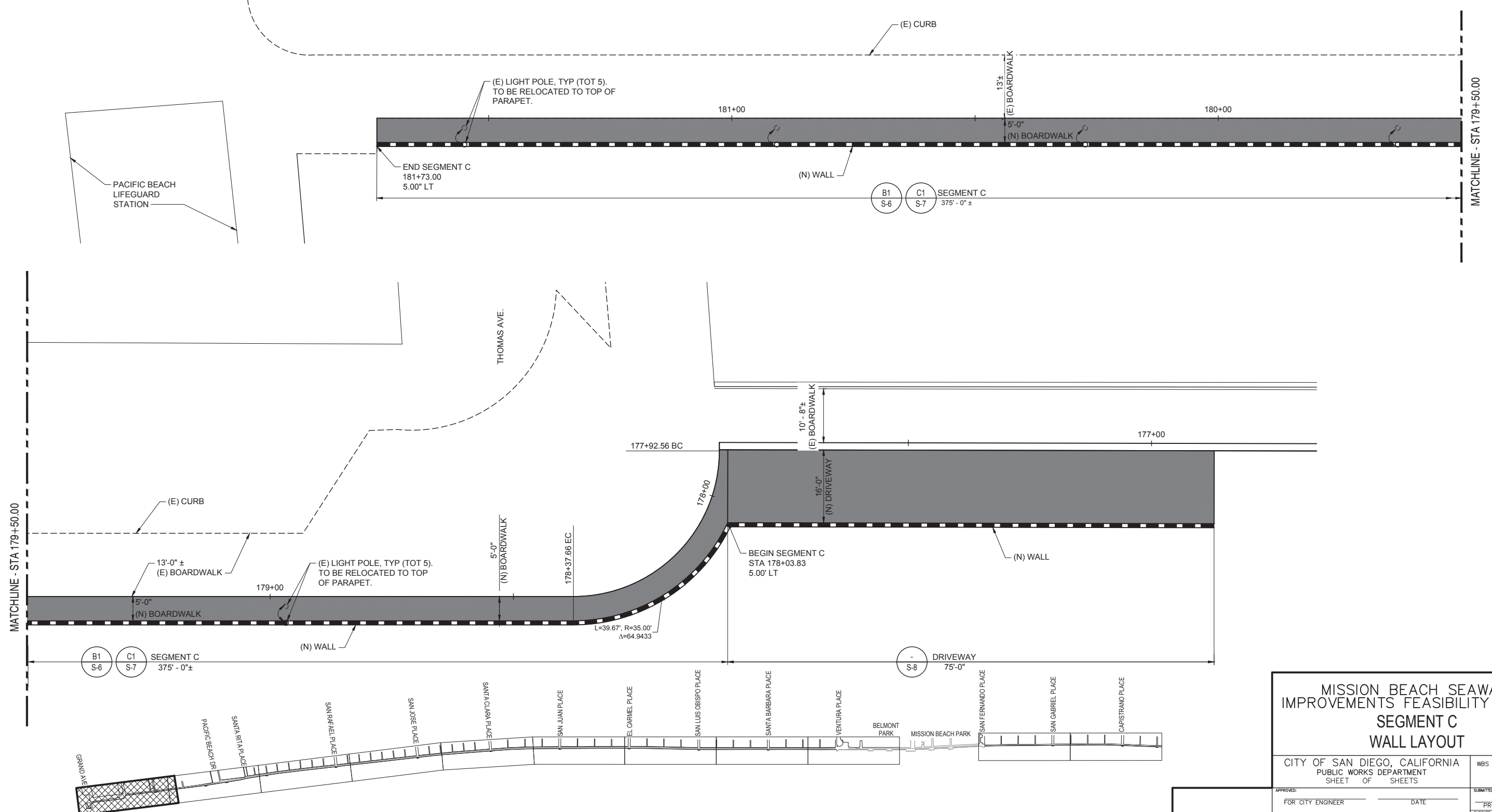

MATCHLINE - STA 179+50.00

MATCHLINE - STA 179+50.00

C-7

MISSION BEACH SEAWALL IMPROVEMENTS FEASIBILITY STUDY  
 SEGMENT C  
 WALL LAYOUT

CITY OF SAN DIEGO, CALIFORNIA  
 PUBLIC WORKS DEPARTMENT  
 SHEET OF SHEETS

APPROVED:		DATE		SUBMITTED BY:	
FOR CITY ENGINEER				PROJECT MANAGER	
PRINT NAME		RCE#		CHECKED BY:	
DESCRIPTION	BY	APPROVED	DATE	FILMED	PROJECT ENGINEER
ORIGINAL	REC				CCS27 COORDINATE
					CCS83 COORDINATE

CONTRACTOR \_\_\_\_\_ DATE STARTED \_\_\_\_\_  
 INSPECTOR \_\_\_\_\_ DATE COMPLETED \_\_\_\_\_

OVERALL KEY PLAN  
 NOT TO SCALE



PRELIMINARY  
 NOT FOR CONSTRUCTION

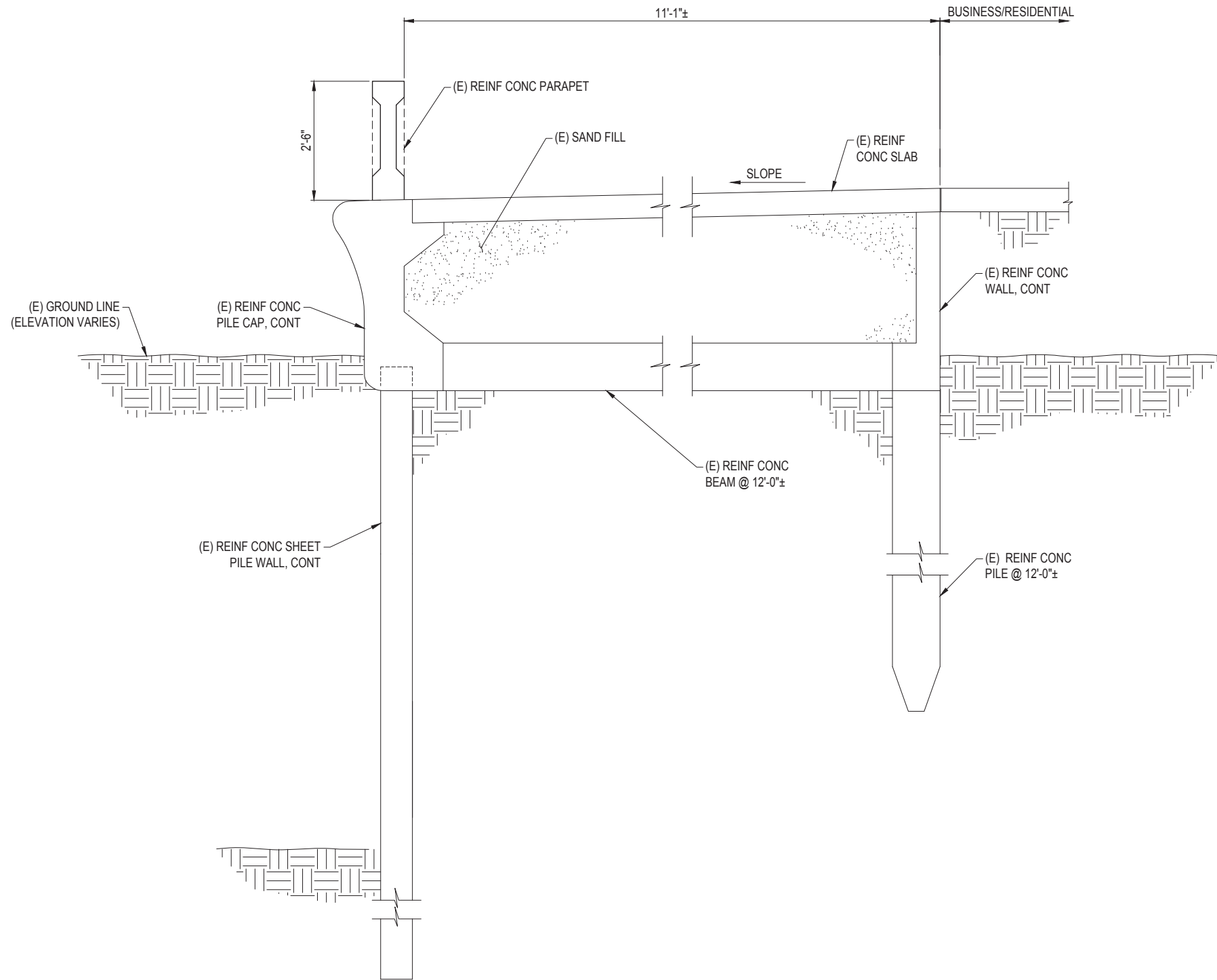

**SEGMENT A - EXISTING SEAWALL**

SCALE: 3/4" = 1'-0"

STA 1+00.00 TO STA 19+85.00  
STA 100+00.00 TO STA 167+73.33

C-1 TO C-6

**A1**



**EXISTING CONDITION - BOARDWALK VIEW**

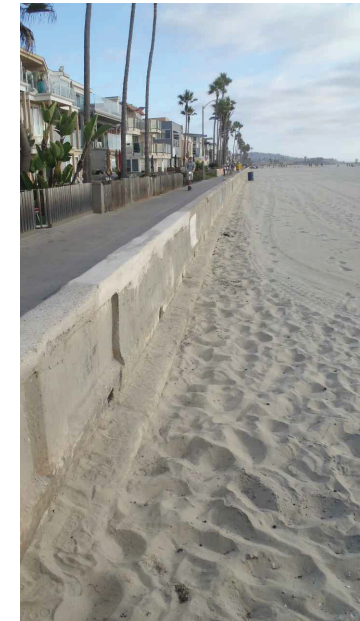

**EXISTING CONDITION - BEACH SIDE VIEW**

**S-1**

**MISSION BEACH SEAWALL IMPROVEMENTS FEASIBILITY STUDY  
SEGMENT A  
EXISTING SEAWALL**

CITY OF SAN DIEGO, CALIFORNIA  
PUBLIC WORKS DEPARTMENT  
SHEET OF SHEETS

APPROVED:					SUBMITTED BY:	
FOR CITY ENGINEER _____ DATE _____					PROJECT MANAGER _____	
PRINT NAME _____ RCE# _____					CHECKED BY: _____	
DESCRIPTION	BY	APPROVED	DATE	FILMED	PROJECT ENGINEER _____	
ORIGINAL	REC				CCS27 COORDINATE _____	
					CCS83 COORDINATE _____	

**PRELIMINARY**  
NOT FOR CONSTRUCTION

CONTRACTOR \_\_\_\_\_ DATE STARTED \_\_\_\_\_  
INSPECTOR \_\_\_\_\_ DATE COMPLETED \_\_\_\_\_

FILE NAME: C:\SA\10278 - Mission Bay PER\CA00146 Seawall\1\_Active\Design\03 STRUCTURAL\10278-F0-S-1.dwg  
PLOTTER: Tuesday, October 11, 2022 - 5:17pm USER: aburro

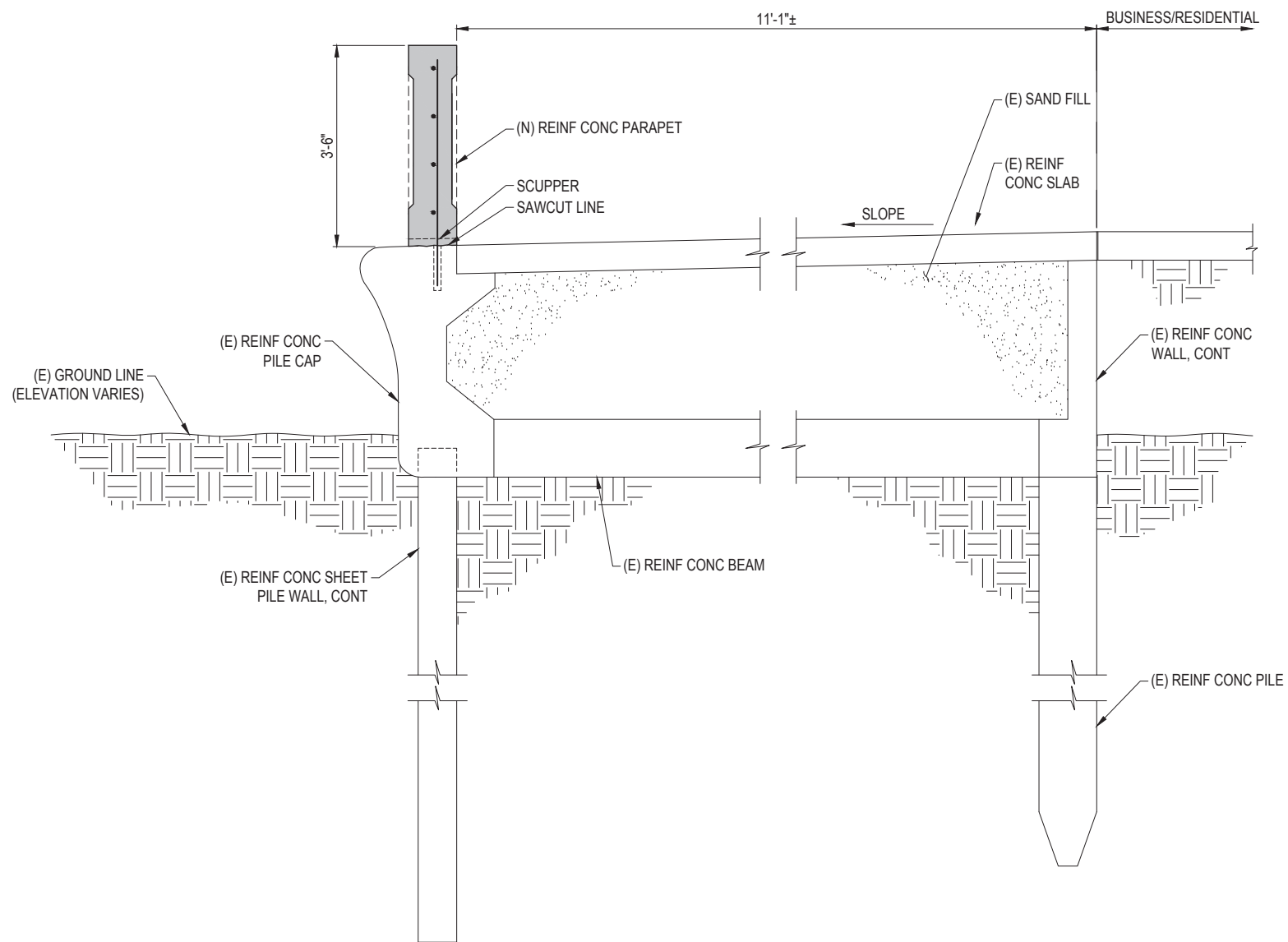

**SEGMENT A - OPTION 1: PARAPET REPLACEMENT**

SCALE: 3/4" = 1'-0"

STA 1+00.00 TO STA 19+85.00

STA 100+00.00 TO STA 167+73.33

C-1 TO C-6

**A1**

**PRELIMINARY**  
NOT FOR CONSTRUCTION

**S - 2**

**MISSION BEACH SEAWALL  
IMPROVEMENTS FEASIBILITY STUDY  
SEGMENT A  
OPTION 1: PARAPET REPLACEMENT**

CITY OF SAN DIEGO, CALIFORNIA  
PUBLIC WORKS DEPARTMENT  
SHEET OF SHEETS

APPROVED:		DATE		SUBMITTED BY:	
FOR CITY ENGINEER				PROJECT MANAGER	
PRINT NAME		RCE#		CHECKED BY:	
DESCRIPTION	BY	APPROVED	DATE	FILMED	PROJECT ENGINEER
ORIGINAL	REC				CCS27 COORDINATE
					CCS83 COORDINATE

CONTRACTOR \_\_\_\_\_ DATE STARTED \_\_\_\_\_  
INSPECTOR \_\_\_\_\_ DATE COMPLETED \_\_\_\_\_

FILE NAME: C:\SA\10278 - Mission Bay PFR\CADD\MB Seawall\Design\03 STRUCTURAL\10278-FG-S-2.dwg  
PLOTTER: Tandy, October 11, 2022 - 5:18pm USER: aburaw

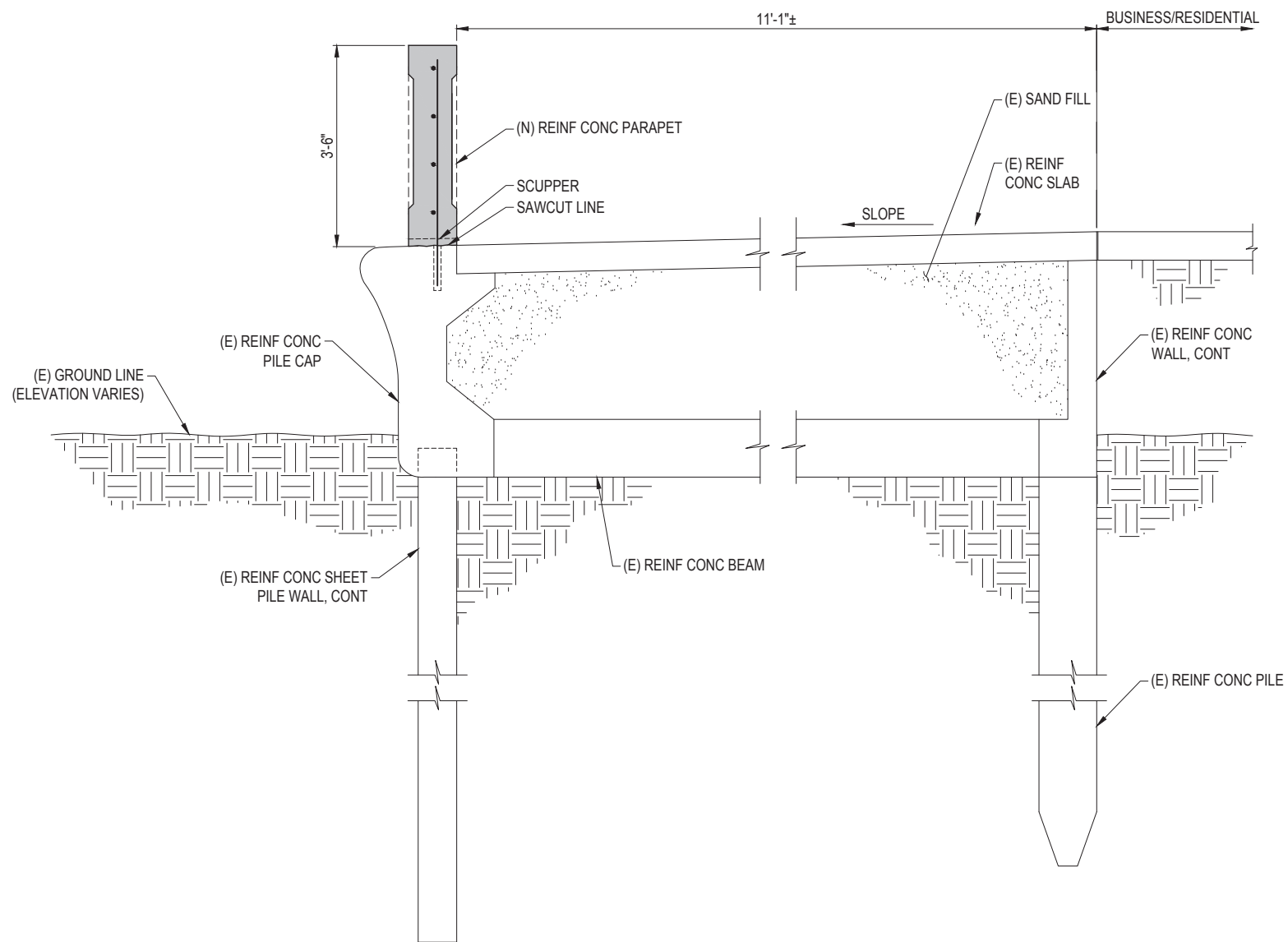

**SEGMENT A - OPTION 1: PARAPET REPLACEMENT**

SCALE: 3/4" = 1'-0"

STA 1+00.00 TO STA 19+85.00

STA 100+00.00 TO STA 167+73.33

C-1 TO C-6

A1

PRELIMINARY  
NOT FOR CONSTRUCTION

S-2

MISSION BEACH SEAWALL  
IMPROVEMENTS FEASIBILITY STUDY  
SEGMENT A  
OPTION 1: PARAPET REPLACEMENT

CITY OF SAN DIEGO, CALIFORNIA  
PUBLIC WORKS DEPARTMENT  
SHEET OF SHEETS

APPROVED:		DATE			SUBMITTED BY:	
FOR CITY ENGINEER					PROJECT MANAGER	
PRINT NAME		RCE#			CHECKED BY:	
DESCRIPTION	BY	APPROVED	DATE	FILMED	PROJECT ENGINEER	
ORIGINAL	REC				CCS27 COORDINATE	
					CCS83 COORDINATE	

CONTRACTOR \_\_\_\_\_ DATE STARTED \_\_\_\_\_  
INSPECTOR \_\_\_\_\_ DATE COMPLETED \_\_\_\_\_

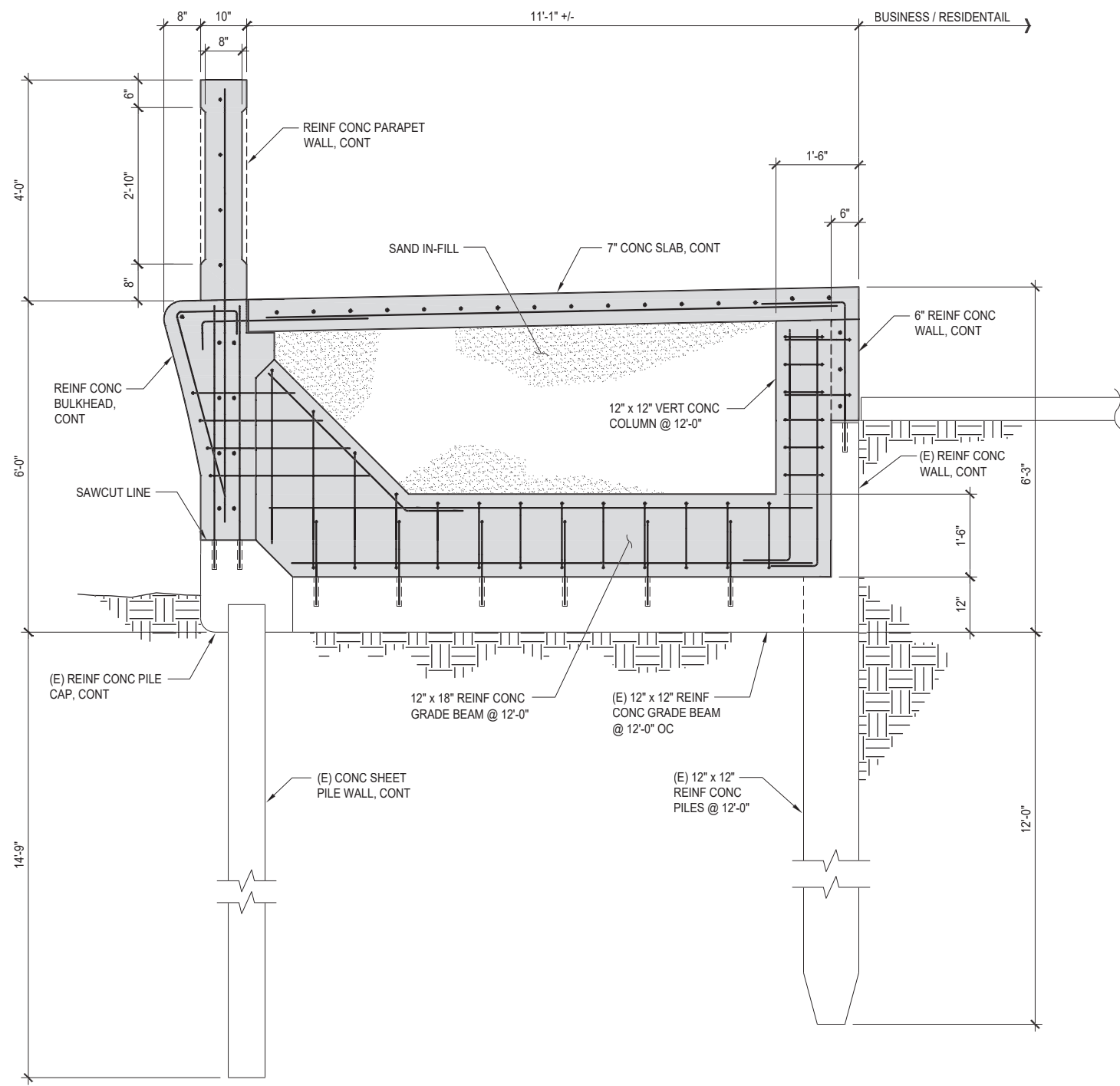

**SEGMENT A - OPTION 2: RAISED BOARDWALK**  
 3/4" = 1'-0"  
 STA 1+00.00 TO STA 19+85.00  
 STA 100+00.00 TO STA 167.73.33

A1



PRELIMINARY  
 NOT FOR CONSTRUCTION

S-3

MISSION BEACH SEAWALL  
 IMPROVEMENTS FEASIBILITY STUDY  
 SEGMENT A  
 OPTION 2: RAISED BOARDWALK

CITY OF SAN DIEGO, CALIFORNIA  
 PUBLIC WORKS DEPARTMENT  
 SHEET OF SHEETS

APPROVED:	DATE	FOR CITY ENGINEER	DATE
PRINT NAME	RCE#	PROJECT MANAGER	CHECKED BY:
DESCRIPTION	BY	APPROVED	DATE
ORIGINAL	REC		

CONTRACTOR \_\_\_\_\_ DATE STARTED \_\_\_\_\_  
 INSPECTOR \_\_\_\_\_ DATE COMPLETED \_\_\_\_\_

FILE NAME: J:\yada\proj\10707600 MISSION BAY PARK ERF\dwg\S - 3.dwg  
 PLOTTED: Monday, November 07, 2022 - 10:34am USER: roud

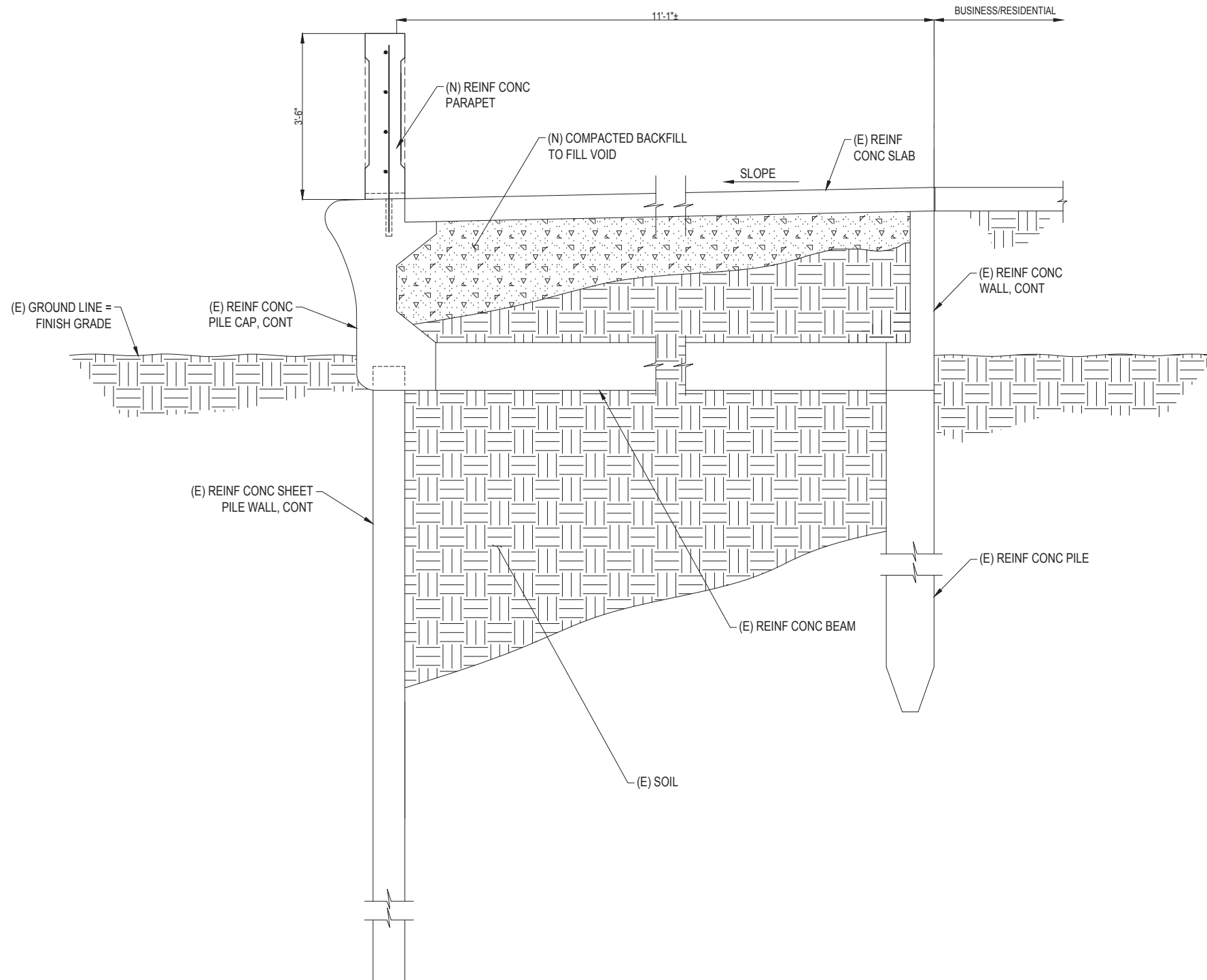

**SEGMENT A - TYPICAL VOID REPAIR**

SCALE: 3/4" = 1'-0"

STA 128+40.00 TO STA 168+30.00

C-1 TO C-6

A1

PRELIMINARY  
NOT FOR CONSTRUCTION

S-4

MISSION BEACH SEAWALL  
IMPROVEMENTS FEASIBILITY STUDY  
SEGMENT A  
TYPICAL VOID REPAIR

CITY OF SAN DIEGO, CALIFORNIA  
PUBLIC WORKS DEPARTMENT  
SHEET OF SHEETS

APPROVED:		DATE		SUBMITTED BY:	
FOR CITY ENGINEER				PROJECT MANAGER	
PRINT NAME		RCE#		CHECKED BY:	
DESCRIPTION	BY	APPROVED	DATE	FILMED	PROJECT ENGINEER
ORIGINAL	REC				CCS27 COORDINATE
					CCS83 COORDINATE

CONTRACTOR \_\_\_\_\_ DATE STARTED \_\_\_\_\_  
INSPECTOR \_\_\_\_\_ DATE COMPLETED \_\_\_\_\_

FILE NAME: C:\SDA\10278 - Mission Bay PWR\CADD\MB Seawall\Active\Design\03 STRUCTURAL\10278-Fig-S-4.dwg  
 PLOTTED: Tuesday, October 11, 2022 - 5:18pm USER: aburra

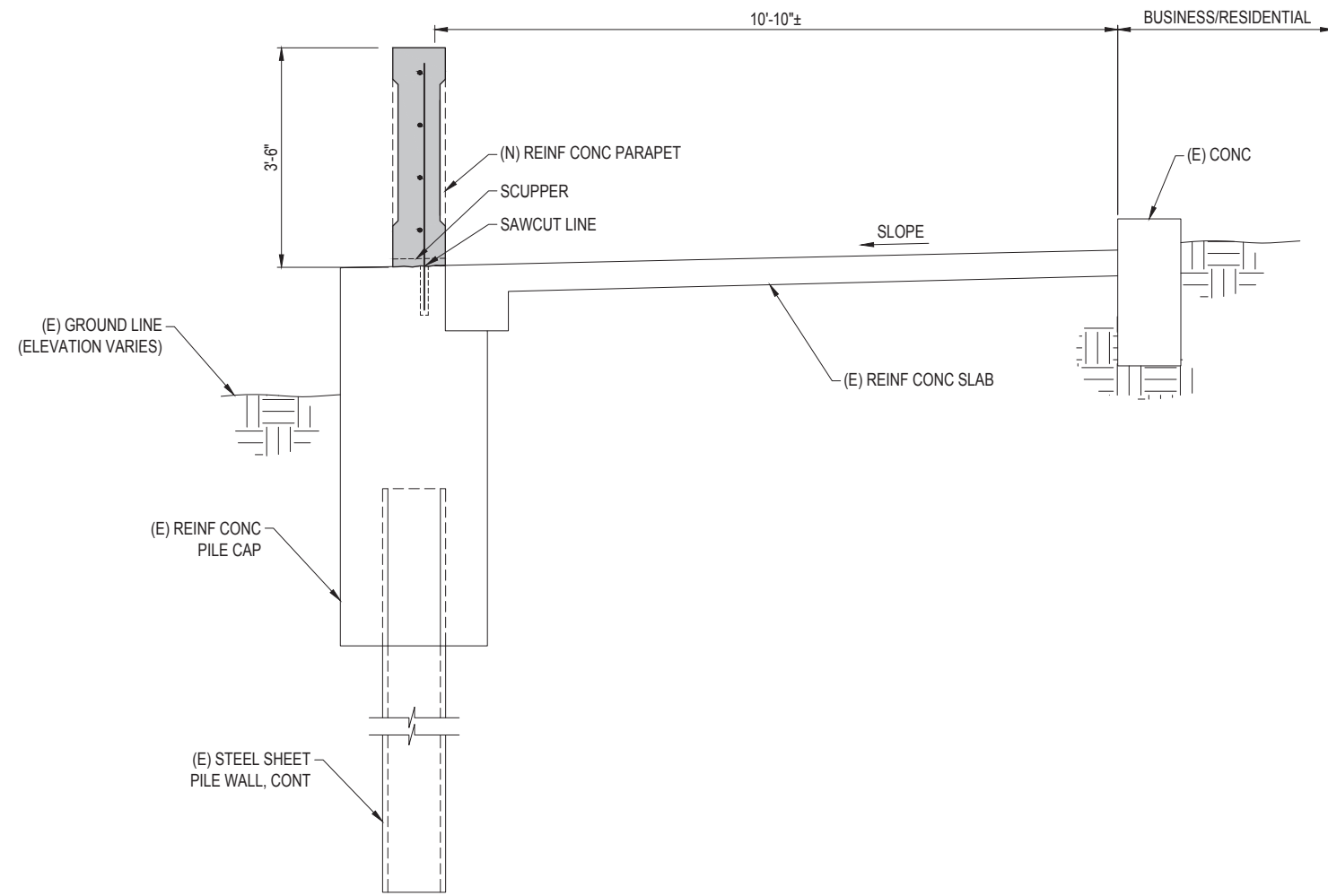

**SEGMENT B - PARAPET REPLACEMENT**

SCALE: 3/4" = 1'-0"

STA 167+73.33 TO STA 177+92.56

C-1

**B1**

**S-5**

**MISSION BEACH SEAWALL  
IMPROVEMENTS FEASIBILITY STUDY  
SEGMENT B  
PARAPET REPLACEMENT**

CITY OF SAN DIEGO, CALIFORNIA  
PUBLIC WORKS DEPARTMENT  
SHEET OF SHEETS

APPROVED:					SUBMITTED BY:	
FOR CITY ENGINEER			DATE		PROJECT MANAGER	
PRINT NAME			RCE#		CHECKED BY:	
DESCRIPTION	BY	APPROVED	DATE	FILMED	PROJECT ENGINEER	
ORIGINAL	REC				CCS27 COORDINATE	
					CCS83 COORDINATE	

**PRELIMINARY**  
NOT FOR CONSTRUCTION

CONTRACTOR \_\_\_\_\_ DATE STARTED \_\_\_\_\_  
INSPECTOR \_\_\_\_\_ DATE COMPLETED \_\_\_\_\_

FILE NAME: C:\SA\10278 - Mission Bay FFR\CADD\MB Seawall\Active\Design\03 STRUCTURAL\10278-FIG-S-5.dwg  
 PLOTTED: Tuesday, October 11, 2022 - 5:18pm USER: aburaw

FILE NAME: C:\S\10278 - Mission Bay PIER\10278 (MB Seawall)\\_Active\\_Design\\_03 STRUCTURAL\10278-Fig-S-6.dwg  
 PLOTTED: Tuesday, October 11, 2022 - 5:18pm USER: aburrow

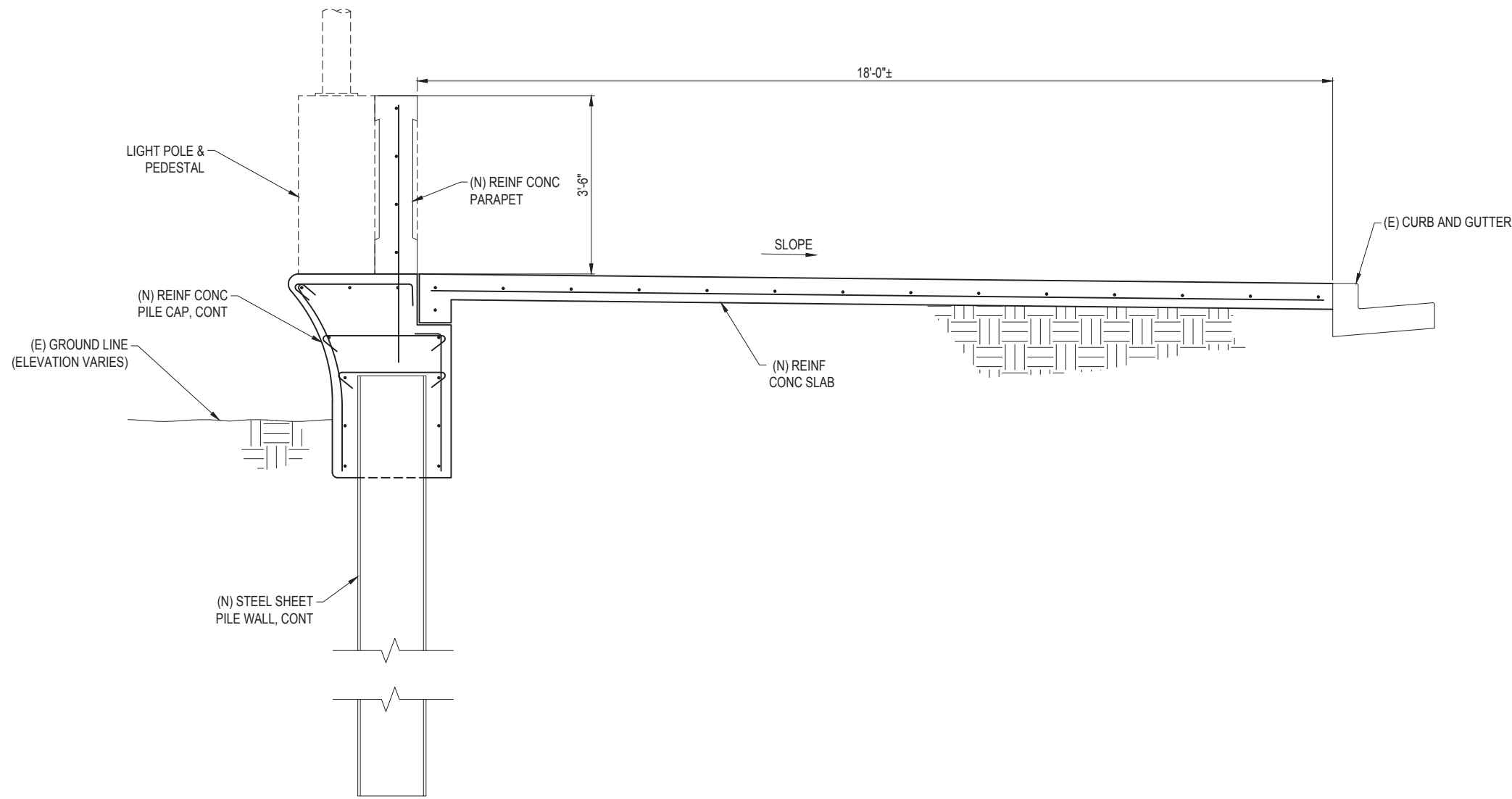

**SEGMENT C - OPTION 1: SEAWALL**

SCALE: 3/4" = 1'-0"

STA 178+03.83 TO STA 181+71.00

C-1

**B1**

**PRELIMINARY**  
NOT FOR CONSTRUCTION

**S - 6**

<b>MISSION BEACH SEAWALL                  IMPROVEMENTS FEASIBILITY STUDY                  SEGMENT C                  OPTION 1: SEAWALL</b>				
CITY OF SAN DIEGO, CALIFORNIA PUBLIC WORKS DEPARTMENT SHEET OF SHEETS				WBS _____
APPROVED: FOR CITY ENGINEER _____ DATE _____		SUBMITTED BY: PROJECT MANAGER _____		
PRINT NAME _____ RCE# _____		CHECKED BY: PROJECT ENGINEER _____		
DESCRIPTION ORIGINAL	BY REC	APPROVED _____	DATE _____	FILMED _____
				CCS27 COORDINATE _____
				CCS83 COORDINATE _____
CONTRACTOR _____		DATE STARTED _____		
INSPECTOR _____		DATE COMPLETED _____		

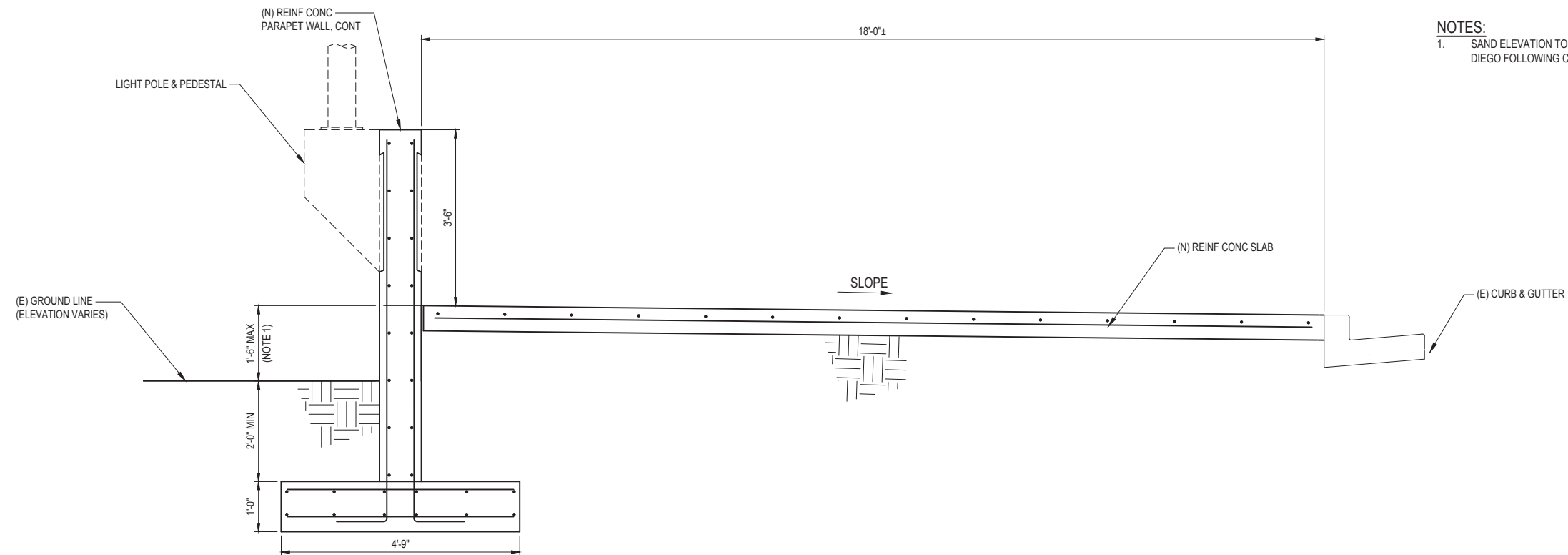

**NOTES:**  
 1. SAND ELEVATION TO BE MAINTAINED BY CITY OF SAN DIEGO FOLLOWING CLOSEOUT OF CONSTRUCTION

**SEGMENT C - OPTION 2: DECORATIVE WALL**

SCALE: 3/4" = 1'-0" STA 178+03.83 TO STA 181+71.00

C-1 **C1**

**S-7**

MISSION BEACH SEAWALL  
 IMPROVEMENTS FEASIBILITY STUDY  
 SEGMENT C  
 OPTION 2: DECORATIVE WALL

CITY OF SAN DIEGO, CALIFORNIA  
 PUBLIC WORKS DEPARTMENT  
 SHEET OF SHEETS

APPROVED:		DATE		SUBMITTED BY:	
FOR CITY ENGINEER				PROJECT MANAGER	
PRINT NAME		RCE#		CHECKED BY:	
DESCRIPTION	BY	APPROVED	DATE	FILMED	PROJECT ENGINEER
ORIGINAL	REC				CCS27 COORDINATE
					CCS83 COORDINATE

**PRELIMINARY**  
 NOT FOR CONSTRUCTION

CONTRACTOR \_\_\_\_\_ DATE STARTED \_\_\_\_\_  
 INSPECTOR \_\_\_\_\_ DATE COMPLETED \_\_\_\_\_

FILE NAME: C:\SDA\10278 - Mission Bay PWR\1001\MB Seawall\1\_Active\Design\03 STRUCTURAL\10278-FIG-S-7.dwg  
 PLOTTED: Tuesday, October 11, 2022 - 5:18pm USER: aburaw

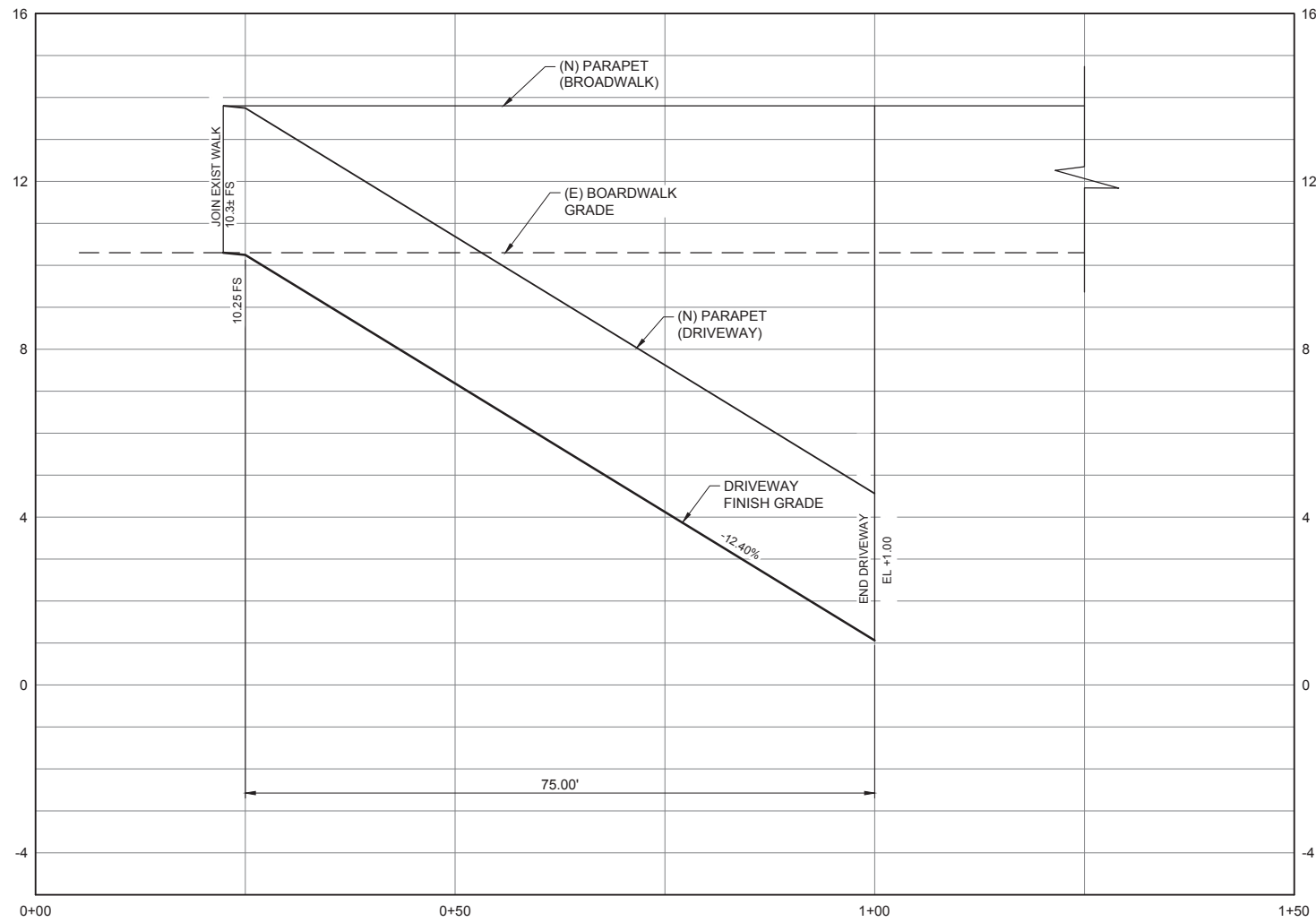

**ELEVATION - DRIVEWAY**

SCALE: HORIZ: 1" = 10'  
VERT: 1" = 2'

C-1 **C1**

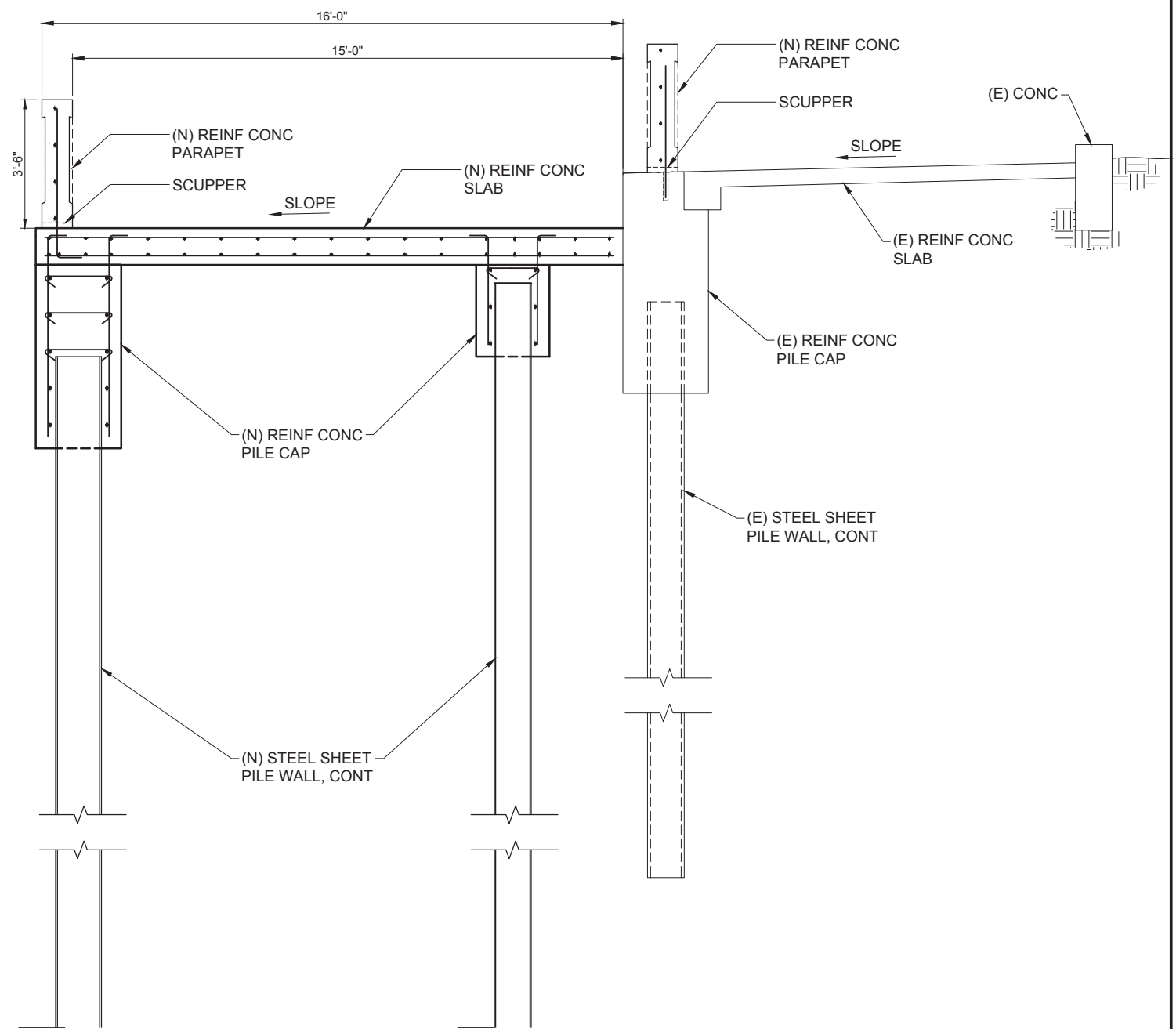

**SECTION - DRIVEWAY**

SCALE: 1/2" = 1'-0"

C-1 **B3**

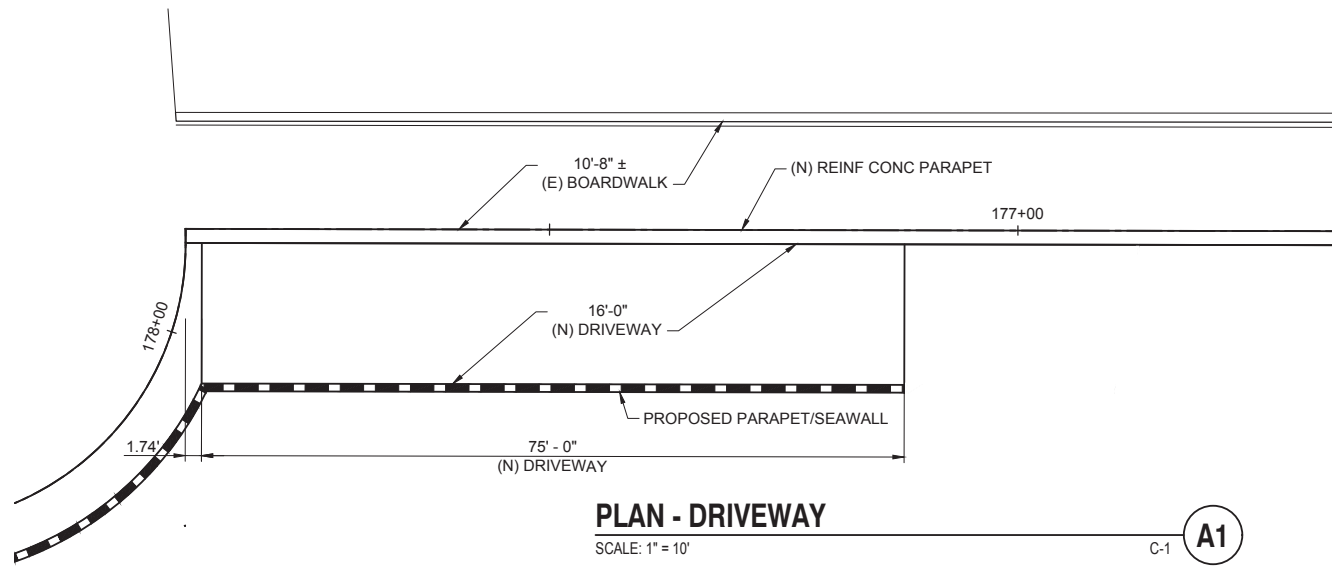

**PLAN - DRIVEWAY**

SCALE: 1" = 10'

C-1 **A1**

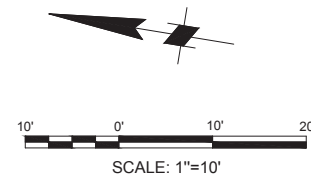

**PRELIMINARY**  
NOT FOR CONSTRUCTION

**S - 8**

**MISSION BEACH SEAWALL IMPROVEMENTS FEASIBILITY STUDY**

**DRIVEWAY**

CITY OF SAN DIEGO, CALIFORNIA  
PUBLIC WORKS DEPARTMENT  
SHEET OF SHEETS

APPROVED:					SUBMITTED BY:				
FOR CITY ENGINEER _____ DATE _____					PROJECT MANAGER _____				
PRINT NAME _____ RCE# _____					CHECKED BY:				
DESCRIPTION	BY	APPROVED	DATE	FILMED	PROJECT ENGINEER _____				
ORIGINAL	REC				CCS27 COORDINATE _____				
					CCS83 COORDINATE _____				
CONTRACTOR _____					DATE STARTED _____				
INSPECTOR _____					DATE COMPLETED _____				

FILE NAME: C:\S\10278 - Mission Bay PER(CAD)(MB Seawall)\\_Active\\_Design\\_03 STRUCTURAL\10278-FIG-5-8.dwg  
 PLOTTED: Tuesday, October 11, 2022 - 5:19pm USER: aburaw

FILE NAME: Q:\SA\10278 - Mission Bay FEIR\AD\MB Seawall\Design\03 STRUCTURAL\10278-FIG-S-9.dwg  
 PLOTTED: Wednesday, October 12, 2022 - 10:20am USER: dburrow

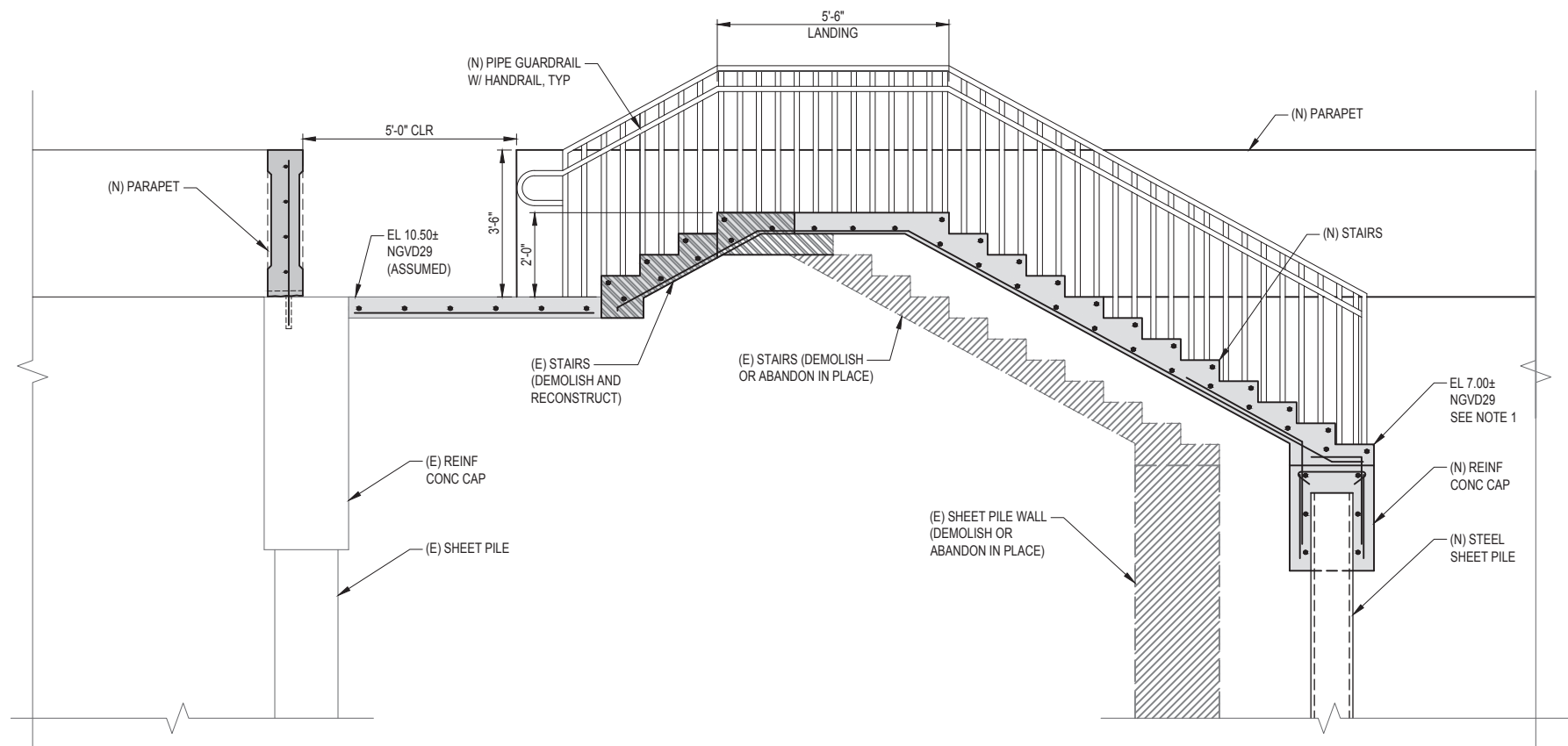

**SECTION - STAIRS**  
 SCALE: 1/2" = 1'-0"

C1

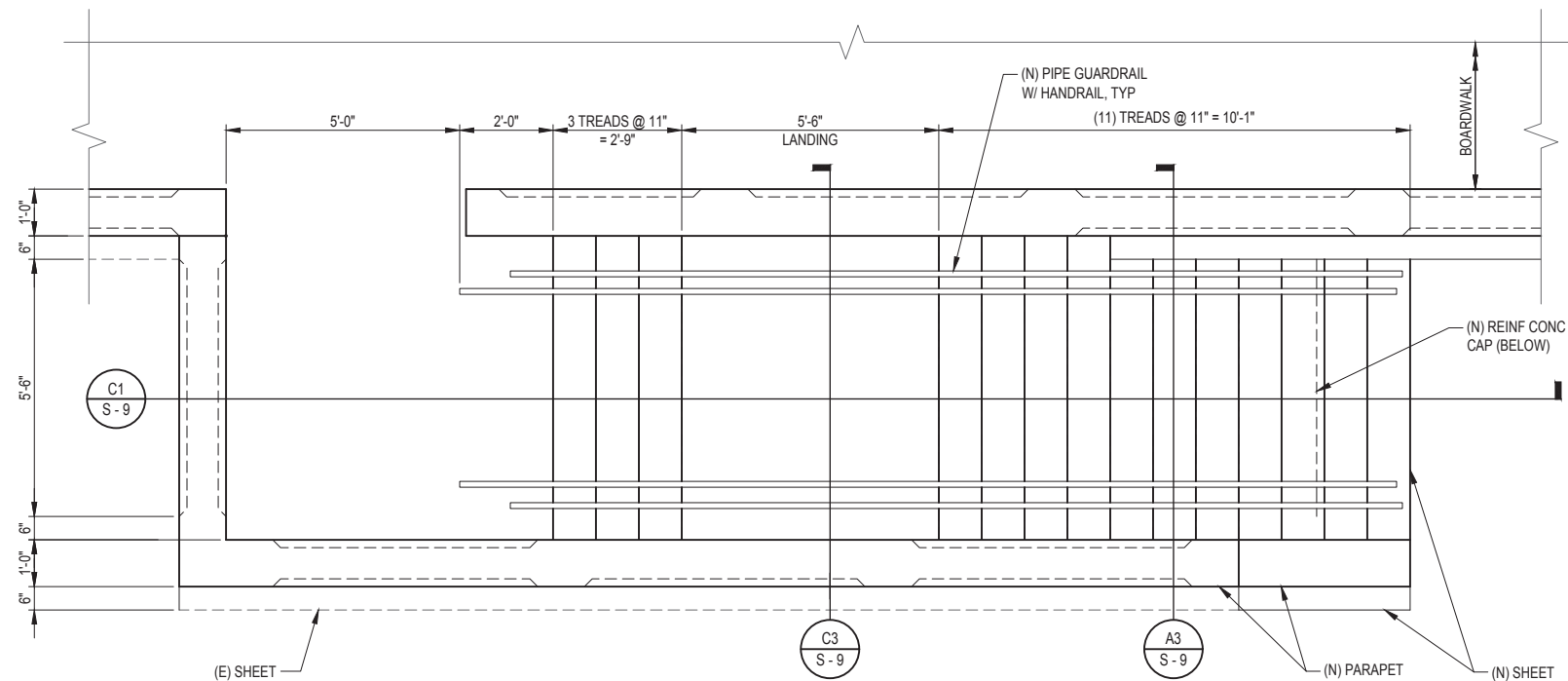

**BEACH ACCESS STAIR PLAN**  
 SCALE: 1/2" = 1'-0"

A1

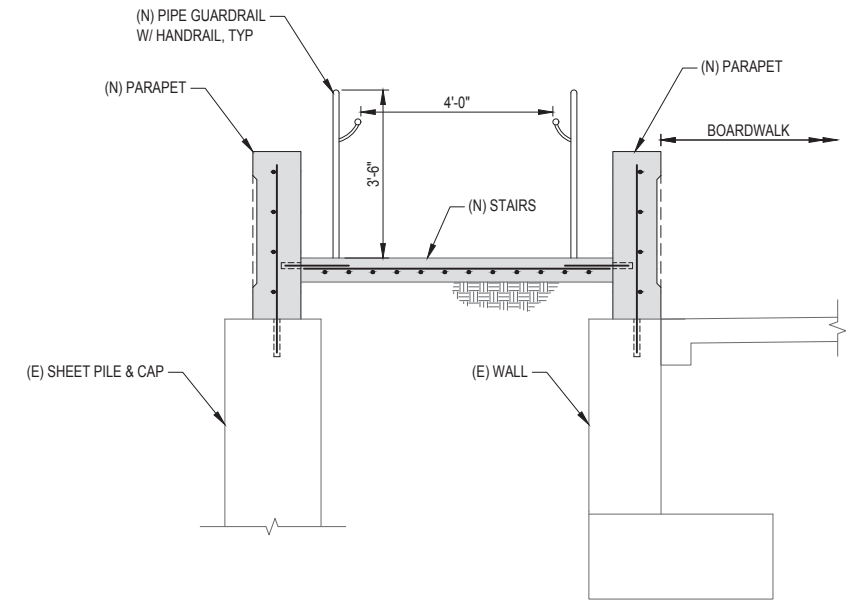

**SECTION**  
 SCALE: 1/2" = 1'-0"

C3

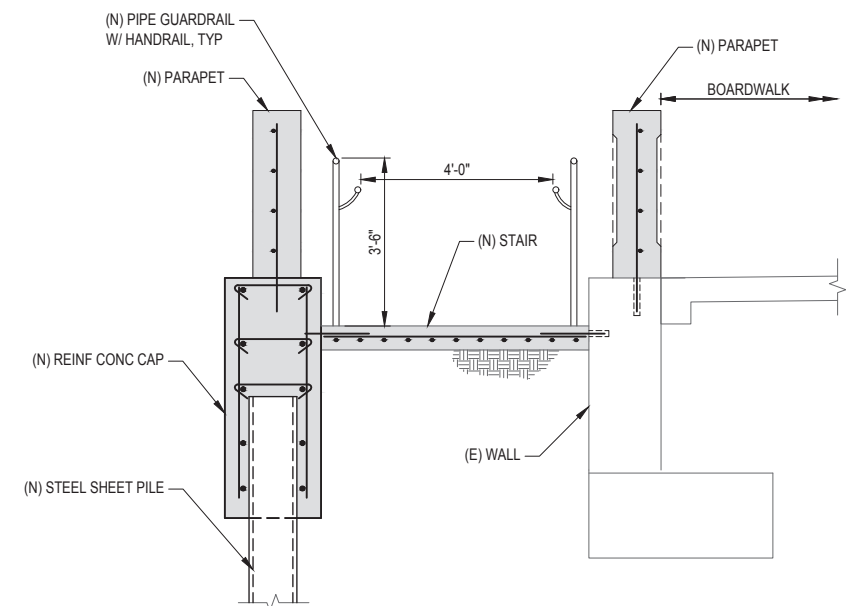

**SECTION**  
 SCALE: 1/2" = 1'-0"

A3

**NOTES:**

- CITY OF SAN DIEGO TO MAINTAIN SAND ELEVATION AT OR ABOVE BOTTOM OF STAIRS FOLLOWING CLOSEOUT OF CONSTRUCTION.

**PRELIMINARY**  
 NOT FOR CONSTRUCTION

S-9

**MISSION BEACH SEAWALL IMPROVEMENTS FEASIBILITY STUDY**

**TYPICAL BEACH ACCESS STAIR**

CITY OF SAN DIEGO, CALIFORNIA  
 PUBLIC WORKS DEPARTMENT  
 SHEET OF SHEETS

APPROVED:		DATE		SUBMITTED BY:	
FOR CITY ENGINEER		DATE		PROJECT MANAGER	
PRINT NAME		RCE#		CHECKED BY:	
DESCRIPTION	BY	APPROVED	DATE	FILMED	PROJECT ENGINEER
ORIGINAL	REC				CCS27 COORDINATE
					CCS83 COORDINATE
CONTRACTOR			DATE STARTED		
INSPECTOR			DATE COMPLETED		

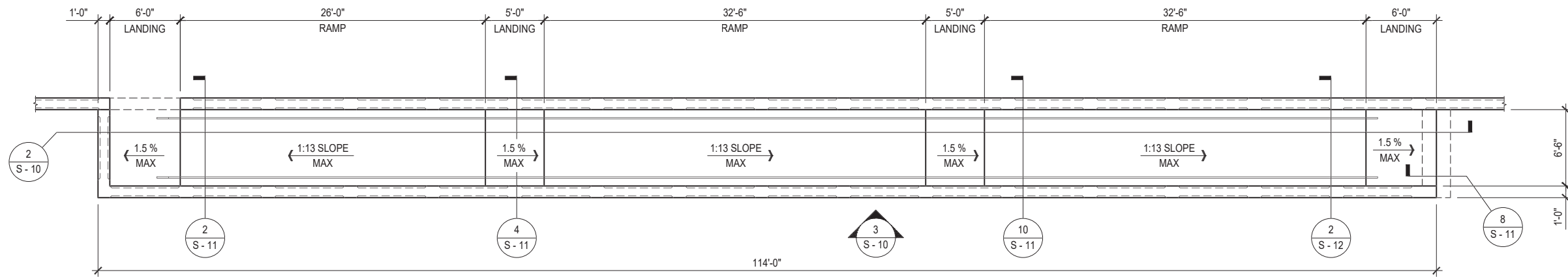

**BEACH ACCESS - RAMP PLAN**

3/16" = 1'-0"

1

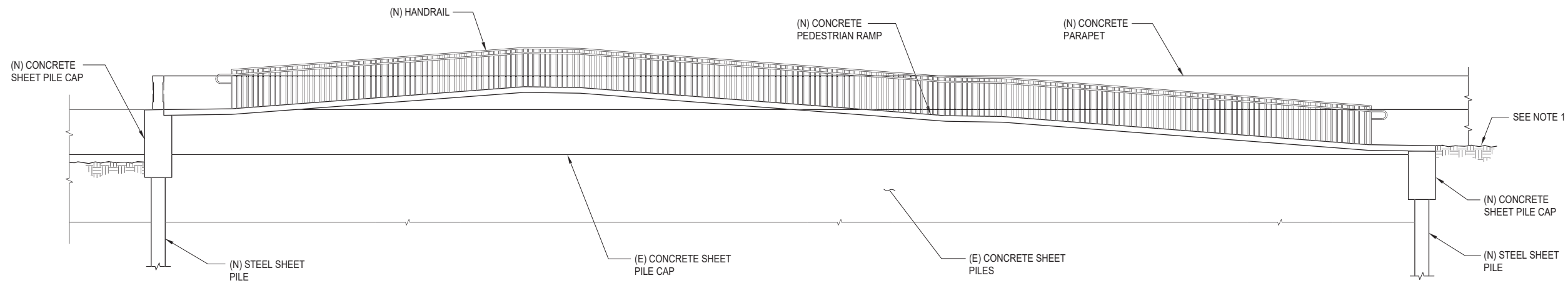

**NOTES:**

- CITY OF SAN DIEGO TO MAINTAIN SAND ELEVATION AT OR ABOVE BOTTOM OF RAMP FOLLOWING CLOSURE OF CONSTRUCTION

**BEACH ACCESS - SECTION RAMP**

3/16" = 1'-0"

2

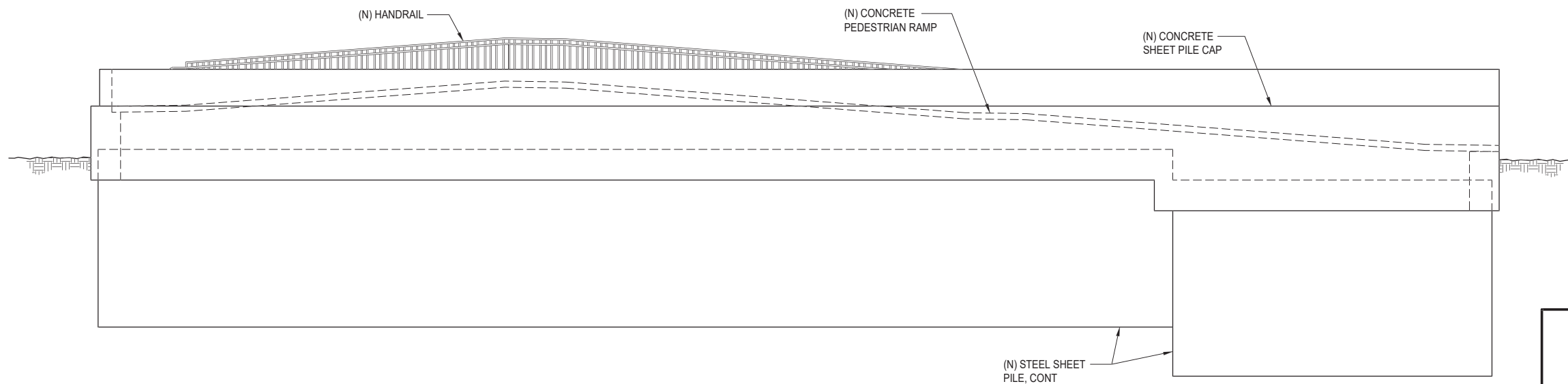

**BEACH ACCESS - WEST ELEVATION RAMP**

3/16" = 1'-0"

3



PRELIMINARY  
NOT FOR CONSTRUCTION

S - 10

**MISSION BEACH SEAWALL IMPROVEMENTS FEASIBILITY STUDY  
TYPICAL BEACH ACCESS RAMP LAYOUT**

CITY OF SAN DIEGO, CALIFORNIA  
PUBLIC WORKS DEPARTMENT  
SHEET OF SHEETS

APPROVED:	DATE	FOR CITY ENGINEER	PROJECT MANAGER
PRINT NAME	RCE#	CHECKED BY:	PROJECT ENGINEER
DESCRIPTION	BY	APPROVED	DATE
ORIGINAL	REC		

CONTRACTOR \_\_\_\_\_ DATE STARTED \_\_\_\_\_  
INSPECTOR \_\_\_\_\_ DATE COMPLETED \_\_\_\_\_

FILE NAME: J:\yada\proj\18076100 MISSION BAY PARK EIR\dwg\S - 10.dwg  
PLOTED: Monday, November 07, 2022 - 10:35am USER: roud

FOR ITEMS NOT NOTED, SEE  $\frac{2}{S-11}$

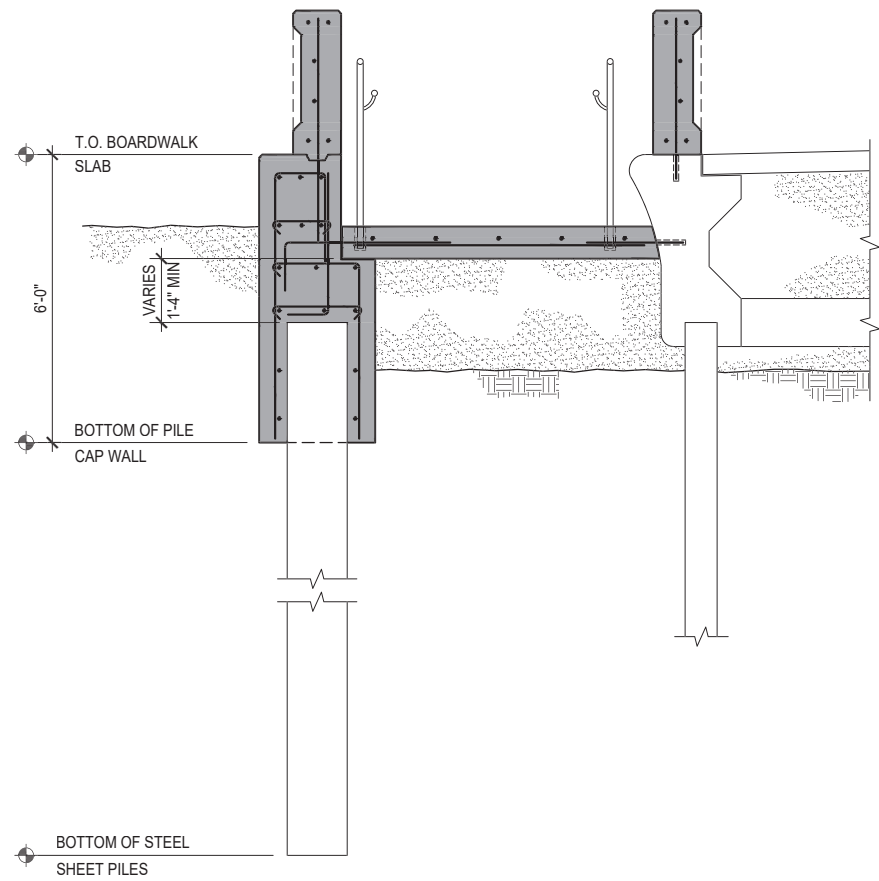

RAMP SECTION  
1/2" = 1'-0"

10

FOR ITEMS NOT NOTED, SEE  $\frac{2}{S-11}$

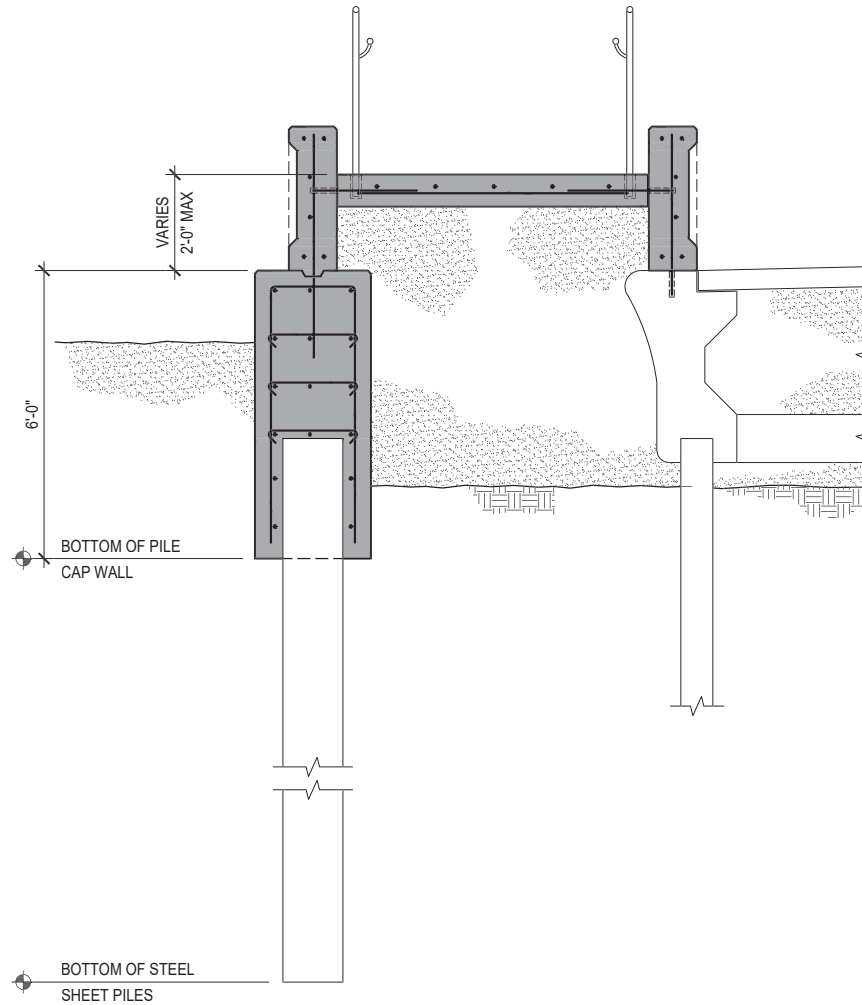

RAMP SECTION  
1/2" = 1'-0"

4

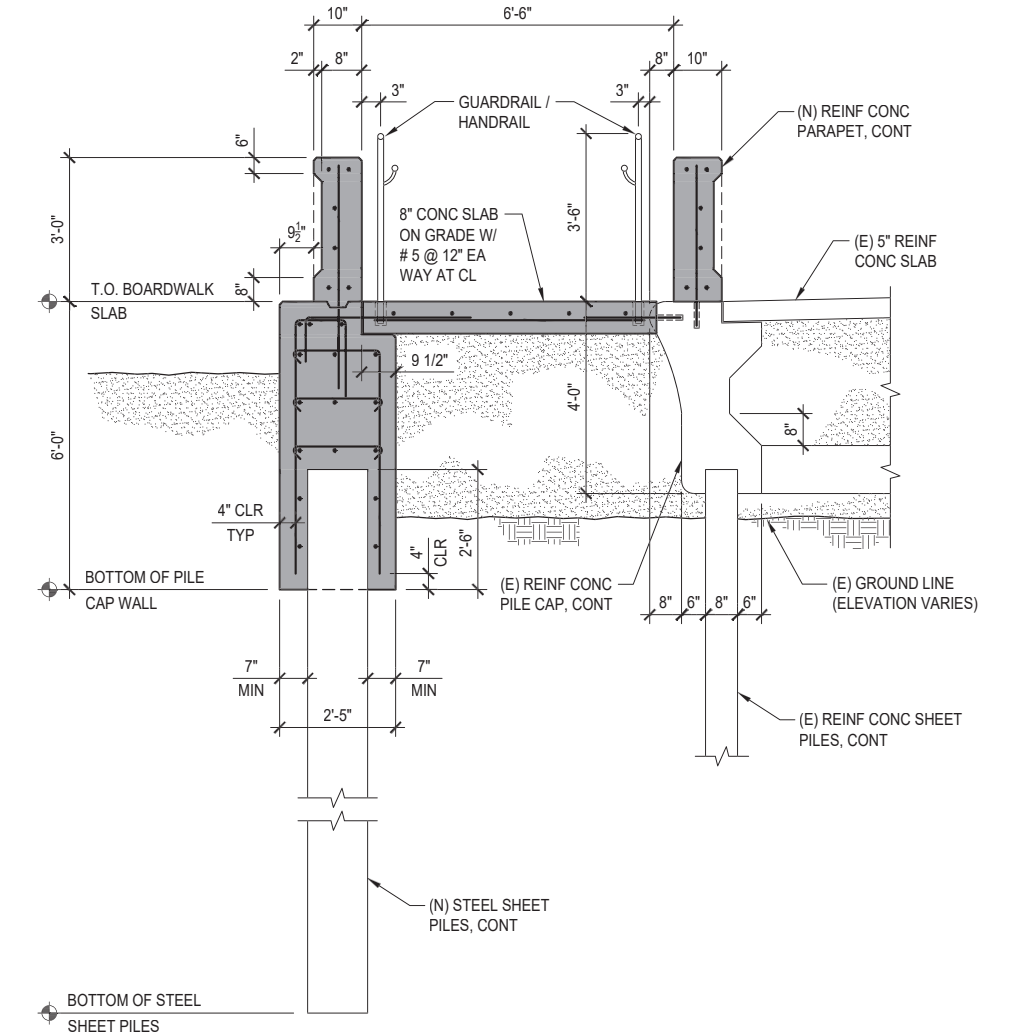

RAMP SECTION  
1/2" = 1'-0"

2

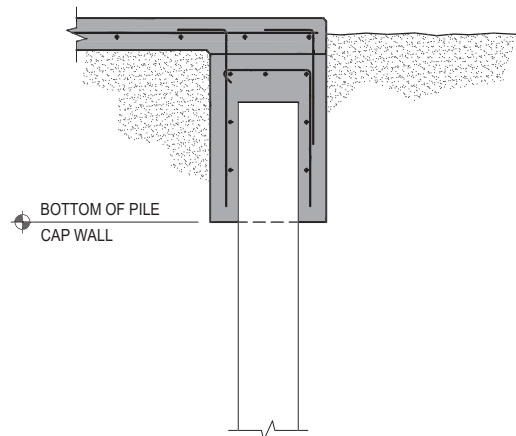

DETAIL  
1/2" = 1'-0"

8



PRELIMINARY  
NOT FOR CONSTRUCTION

S - 11

MISSION BEACH SEAWALL IMPROVEMENTS FEASIBILITY STUDY  
TYPICAL BEACH ACCESS RAMP  
DETAILS NO.1

CITY OF SAN DIEGO, CALIFORNIA  
PUBLIC WORKS DEPARTMENT  
SHEET OF SHEETS

APPROVED:	DATE	FOR CITY ENGINEER	PROJECT MANAGER	
PRINT NAME	RCE#	CHECKED BY:	PROJECT ENGINEER	
DESCRIPTION	BY	APPROVED	DATE	FILMED
ORIGINAL	REC			

CONTRACTOR \_\_\_\_\_ DATE STARTED \_\_\_\_\_  
INSPECTOR \_\_\_\_\_ DATE COMPLETED \_\_\_\_\_

FILE NAME: J:\yada\proj\1707500\_MISSON\_BCH\_PARK\_ER\dwg\S - 11.dwg  
PLOTTER: Monby, November 07, 2022 - 10:56am USER: roud

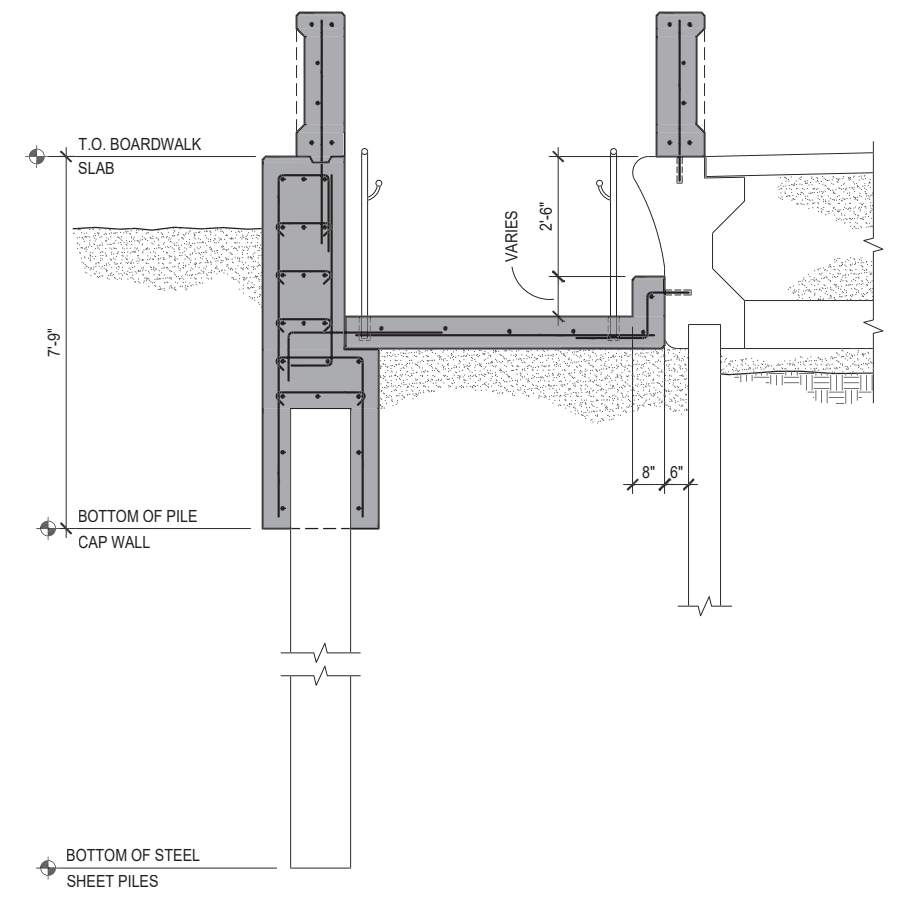

**RAMP SECTION**  
1/2" = 1'-0"



**PRELIMINARY**  
NOT FOR CONSTRUCTION

**S - 12**

**MISSION BEACH SEAWALL IMPROVEMENTS FEASIBILITY STUDY  
TYPICAL BEACH ACCESS RAMP  
DETAILS NO.2**

CITY OF SAN DIEGO, CALIFORNIA  
PUBLIC WORKS DEPARTMENT  
SHEET OF SHEETS

APPROVED:	DATE	FOR CITY ENGINEER	DATE
PRINT NAME	RCE#	PROJECT MANAGER	CHECKED BY:
DESCRIPTION	BY	APPROVED	DATE
ORIGINAL	REC		

CONTRACTOR \_\_\_\_\_ DATE STARTED \_\_\_\_\_  
INSPECTOR \_\_\_\_\_ DATE COMPLETED \_\_\_\_\_



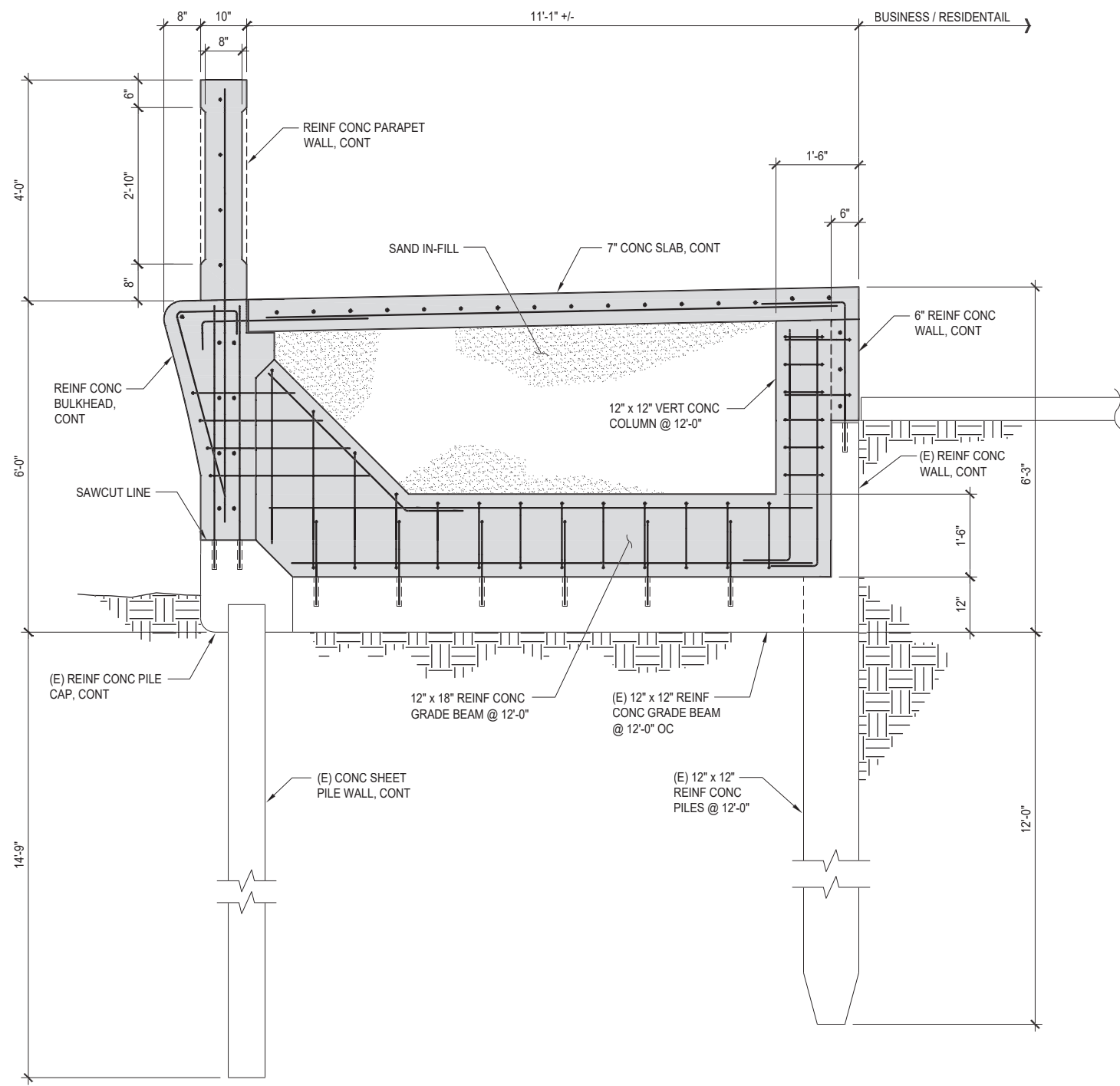

**SEGMENT A - OPTION 2: RAISED BOARDWALK**

3/4" = 1'-0"  
 STA 1+00.00 TO STA 19+85.00  
 STA 100+00.00 TO STA 167.73.33

A1



PRELIMINARY  
 NOT FOR CONSTRUCTION

S-3

**MISSION BEACH SEAWALL IMPROVEMENTS FEASIBILITY STUDY  
 SEGMENT A  
 OPTION 2: RAISED BOARDWALK**

CITY OF SAN DIEGO, CALIFORNIA  
 PUBLIC WORKS DEPARTMENT  
 SHEET OF SHEETS

APPROVED:	DATE	FOR CITY ENGINEER	DATE
PRINT NAME	RCE#	PROJECT MANAGER	CHECKED BY:
DESCRIPTION	BY	APPROVED	DATE
ORIGINAL	REC		

CONTRACTOR \_\_\_\_\_ DATE STARTED \_\_\_\_\_  
 INSPECTOR \_\_\_\_\_ DATE COMPLETED \_\_\_\_\_

FILE NAME: J:\yada\proj\10707600 MISSION BAY PARK ERF\dwg\S - 3.dwg  
 PLOTTED: Monday, November 07, 2022 - 10:34am USER: roud

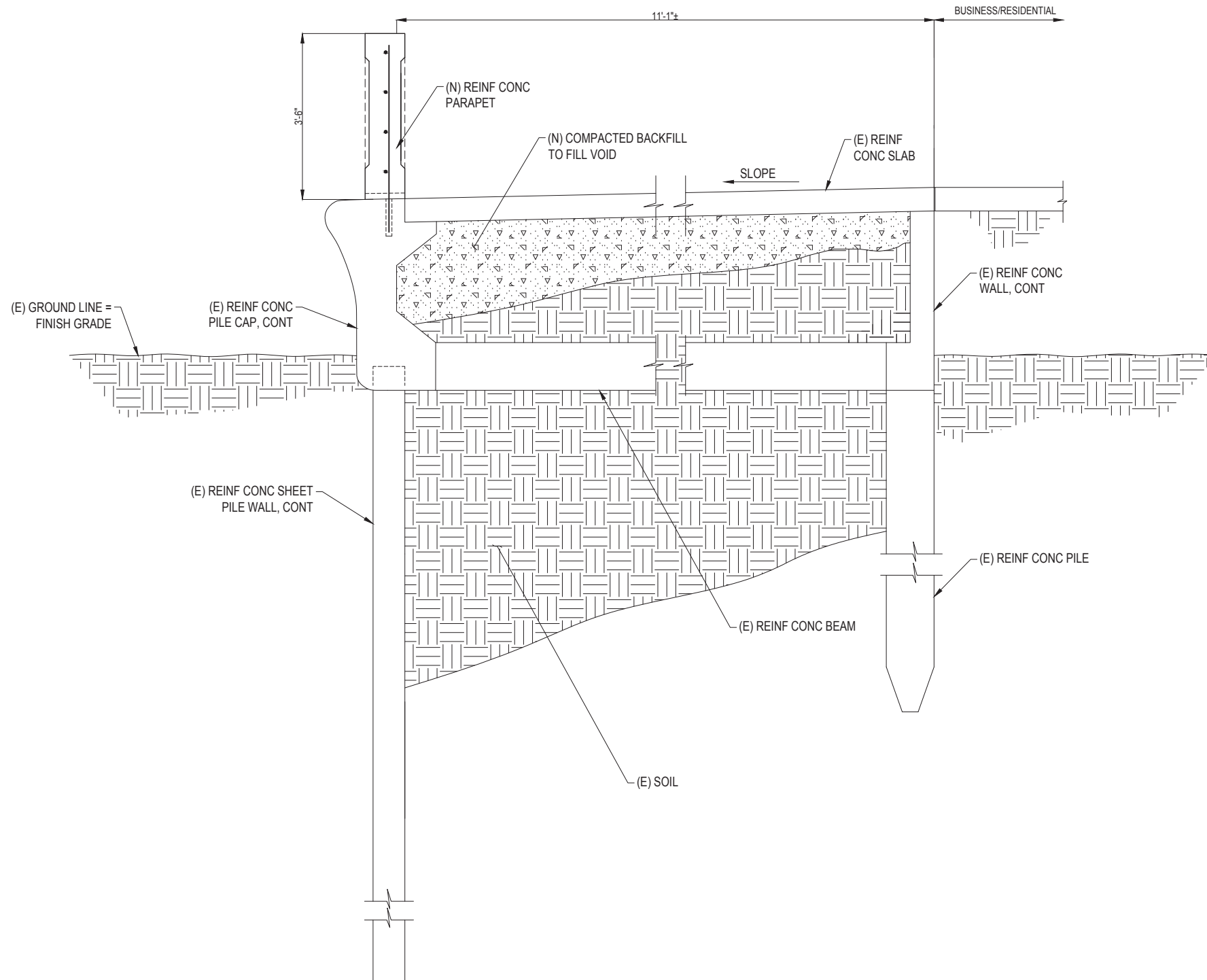

**SEGMENT A - TYPICAL VOID REPAIR**

SCALE: 3/4" = 1'-0"

STA 128+40.00 TO STA 168+30.00

C-1 TO C-6

A1

PRELIMINARY  
NOT FOR CONSTRUCTION

S-4

MISSION BEACH SEAWALL  
IMPROVEMENTS FEASIBILITY STUDY  
SEGMENT A  
TYPICAL VOID REPAIR

CITY OF SAN DIEGO, CALIFORNIA  
PUBLIC WORKS DEPARTMENT  
SHEET OF SHEETS

APPROVED:		DATE		SUBMITTED BY:	
FOR CITY ENGINEER				PROJECT MANAGER	
PRINT NAME		RCE#		CHECKED BY:	
DESCRIPTION	BY	APPROVED	DATE	FILMED	PROJECT ENGINEER
ORIGINAL	REC				CCS27 COORDINATE
					CCS83 COORDINATE

CONTRACTOR \_\_\_\_\_ DATE STARTED \_\_\_\_\_  
INSPECTOR \_\_\_\_\_ DATE COMPLETED \_\_\_\_\_

FILE NAME: C:\SDA\10278 - Mission Bay FFR\CADD\MB Seawall\1\_Active\Design\03 STRUCTURAL\10278-FR-5-4.dwg  
 PLOTTED: Tuesday, October 11, 2022 - 5:18pm USER: aburaw

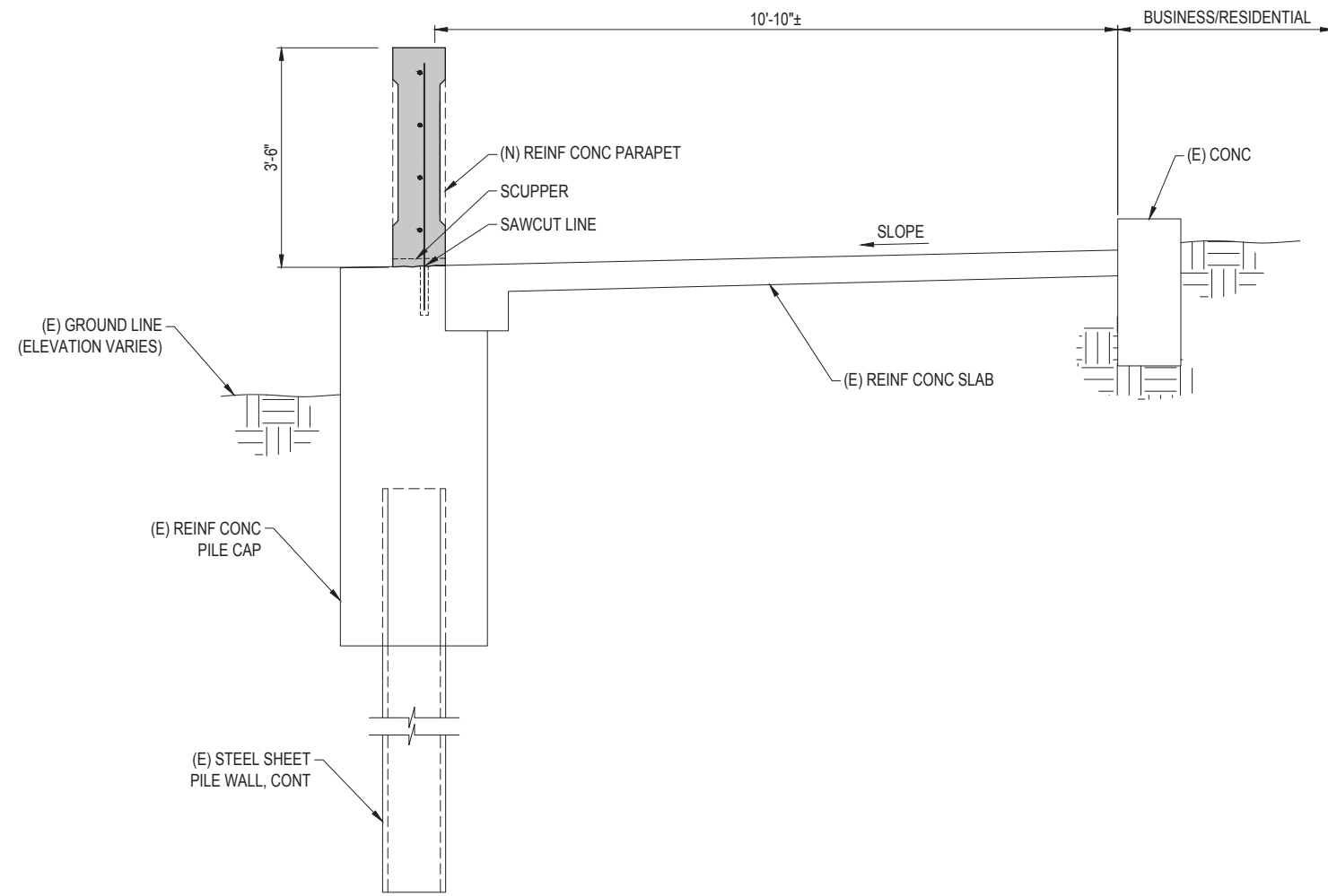

**SEGMENT B - PARAPET REPLACEMENT**

SCALE: 3/4" = 1'-0"

STA 167+73.33 TO STA 177+92.56

C-1 **B1**

**S-5**

**MISSION BEACH SEAWALL  
IMPROVEMENTS FEASIBILITY STUDY  
SEGMENT B  
PARAPET REPLACEMENT**

CITY OF SAN DIEGO, CALIFORNIA  
PUBLIC WORKS DEPARTMENT  
SHEET OF SHEETS

APPROVED:					SUBMITTED BY:	
FOR CITY ENGINEER _____ DATE _____					PROJECT MANAGER _____	
PRINT NAME _____ RCE# _____					CHECKED BY:	
DESCRIPTION	BY	APPROVED	DATE	FILMED	PROJECT ENGINEER _____	
ORIGINAL	REC				CCS27 COORDINATE _____	
					CCS83 COORDINATE _____	

**PRELIMINARY**  
NOT FOR CONSTRUCTION

CONTRACTOR \_\_\_\_\_ DATE STARTED \_\_\_\_\_  
INSPECTOR \_\_\_\_\_ DATE COMPLETED \_\_\_\_\_

FILE NAME: C:\SA\10278 - Mission Bay FFR\CADD\MB Seawall\Design\03 STRUCTURAL\10278-Fig-S-5.dwg  
PLOTTER: Tandy, October 11, 2022 - 5:08pm USER: aburaw

FILE NAME: C:\SDA\10278 - Mission Bay PER\1001\MB Seawall\1\_Active\Design\03 STRUCTURAL\10278-Fig-S-6.dwg  
 PLOTTED: Tuesday, October 11, 2022 - 5:18pm USER: aburrow

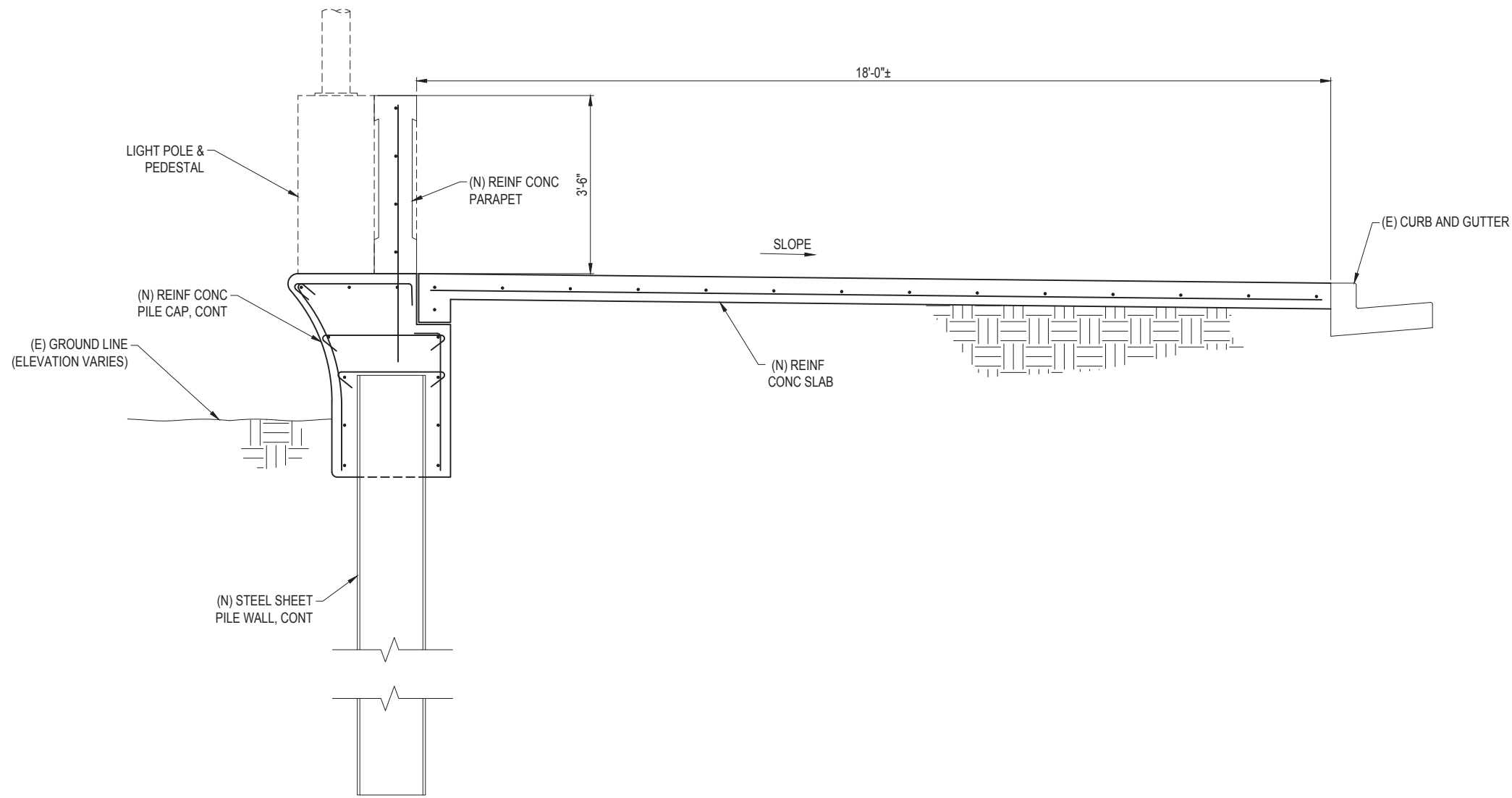

**SEGMENT C - OPTION 1: SEAWALL**

SCALE: 3/4" = 1'-0"

STA 178+03.83 TO STA 181+71.00

C-1

**B1**

**PRELIMINARY**  
NOT FOR CONSTRUCTION

**S - 6**

**MISSION BEACH SEAWALL  
IMPROVEMENTS FEASIBILITY STUDY  
SEGMENT C  
OPTION 1: SEAWALL**

CITY OF SAN DIEGO, CALIFORNIA  
PUBLIC WORKS DEPARTMENT  
SHEET OF SHEETS

APPROVED:		DATE		SUBMITTED BY:	
FOR CITY ENGINEER				PROJECT MANAGER	
PRINT NAME		RCE#		CHECKED BY:	
DESCRIPTION	BY	APPROVED	DATE	FILMED	PROJECT ENGINEER
ORIGINAL	REC				CCS27 COORDINATE
					CCS83 COORDINATE

CONTRACTOR \_\_\_\_\_ DATE STARTED \_\_\_\_\_  
 INSPECTOR \_\_\_\_\_ DATE COMPLETED \_\_\_\_\_

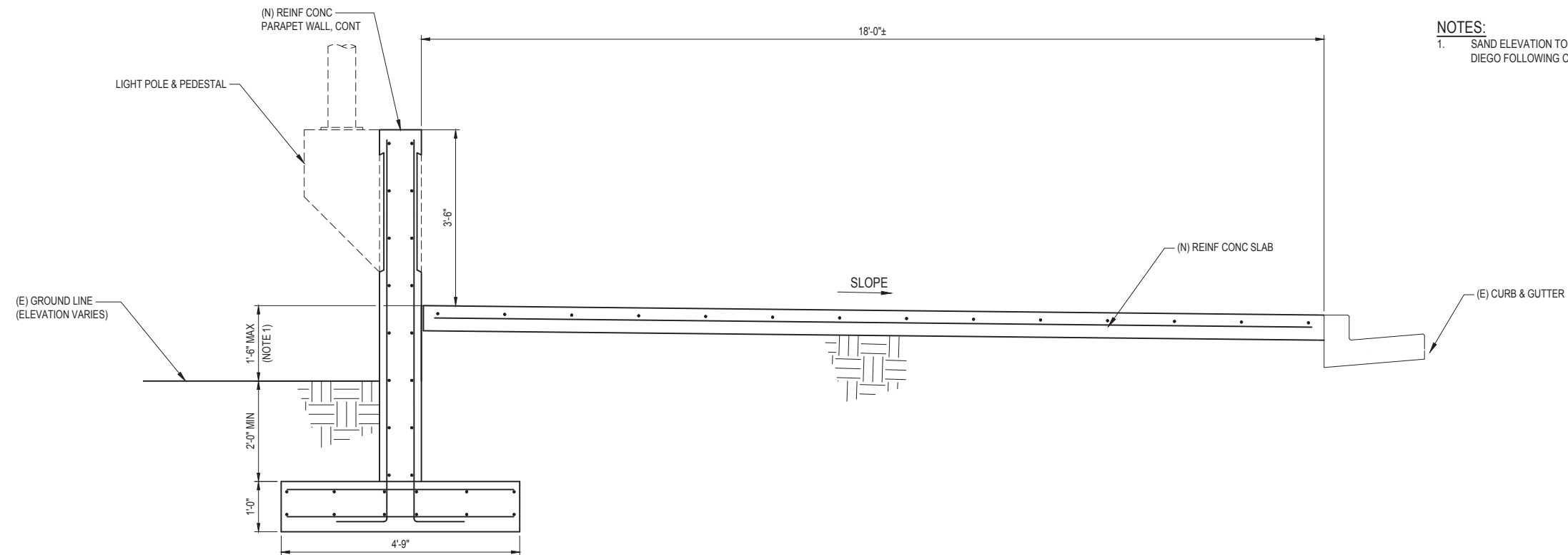

**NOTES:**  
 1. SAND ELEVATION TO BE MAINTAINED BY CITY OF SAN DIEGO FOLLOWING CLOSEOUT OF CONSTRUCTION

**SEGMENT C - OPTION 2: DECORATIVE WALL**  
 SCALE: 3/4" = 1'-0" STA 178+03.83 TO STA 181+71.00

C-1 **C1**

S-7

MISSION BEACH SEAWALL  
 IMPROVEMENTS FEASIBILITY STUDY  
 SEGMENT C  
 OPTION 2: DECORATIVE WALL

CITY OF SAN DIEGO, CALIFORNIA  
 PUBLIC WORKS DEPARTMENT  
 SHEET OF SHEETS

APPROVED:		DATE		SUBMITTED BY:	
FOR CITY ENGINEER				PROJECT MANAGER	
PRINT NAME		RCE#		CHECKED BY:	
DESCRIPTION	BY	APPROVED	DATE	FILMED	PROJECT ENGINEER
ORIGINAL	REC				CCS27 COORDINATE
					CCS83 COORDINATE

**PRELIMINARY**  
 NOT FOR CONSTRUCTION

CONTRACTOR \_\_\_\_\_ DATE STARTED \_\_\_\_\_  
 INSPECTOR \_\_\_\_\_ DATE COMPLETED \_\_\_\_\_



FILE NAME: Q:\SA\10278 - Mission Bay FEIR\AD\MB Seawall\Design\03 STRUCTURAL\10278-FIG-S-9.dwg  
 PLOTTED: Wednesday, October 12, 2022 - 10:20am USER: dburrow

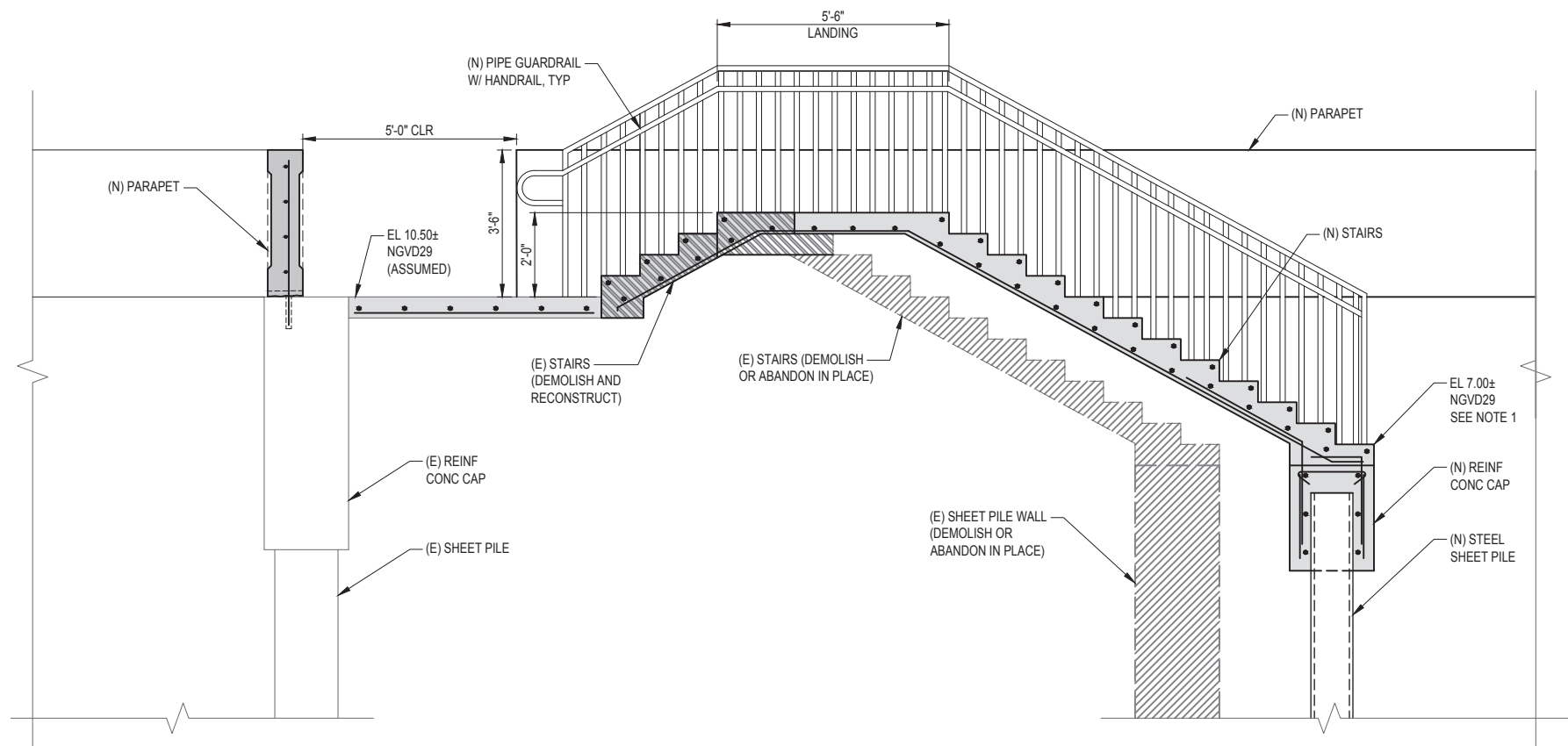

**SECTION - STAIRS**

SCALE: 1/2" = 1'-0"

C1

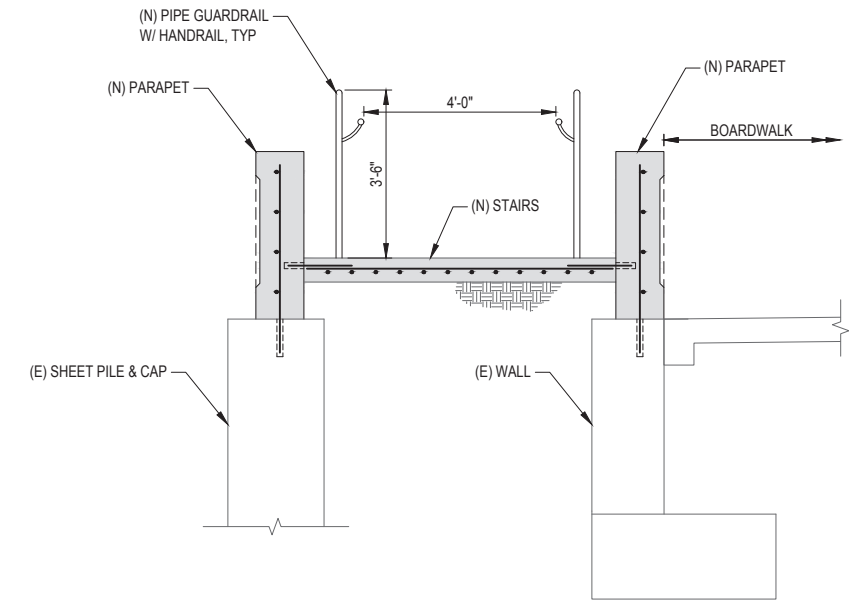

**SECTION**

SCALE: 1/2" = 1'-0"

C3

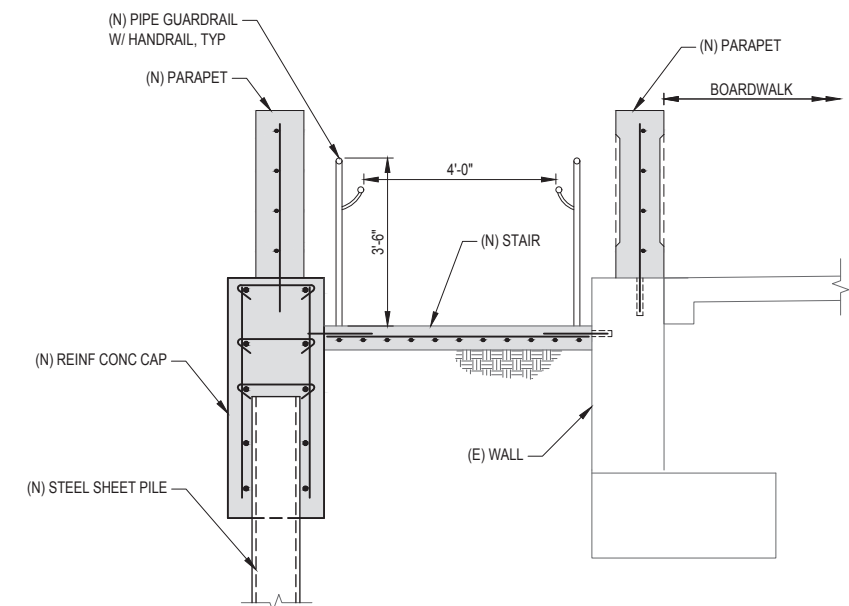

**SECTION**

SCALE: 1/2" = 1'-0"

A3

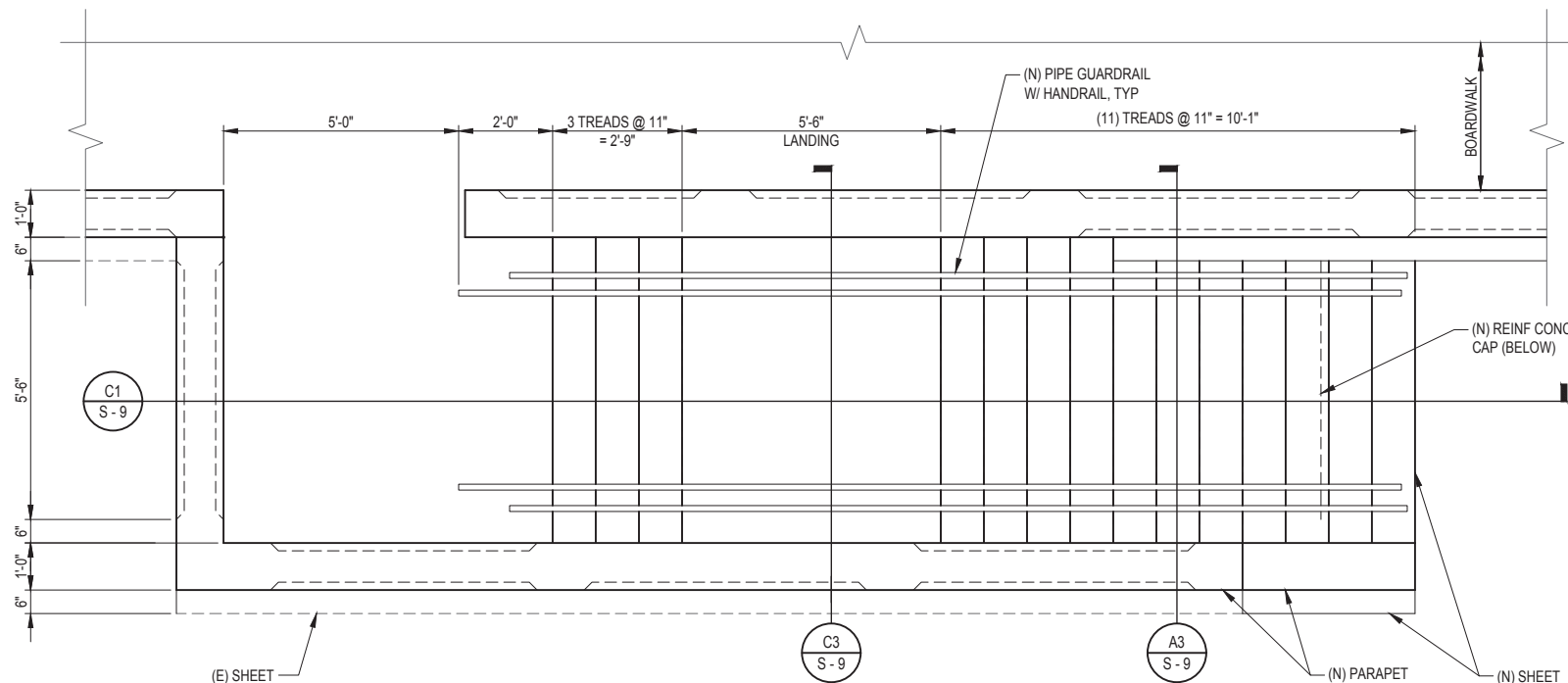

**BEACH ACCESS STAIR PLAN**

SCALE: 1/2" = 1'-0"

A1

**NOTES:**

- CITY OF SAN DIEGO TO MAINTAIN SAND ELEVATION AT OR ABOVE BOTTOM OF STAIRS FOLLOWING CLOSEOUT OF CONSTRUCTION.

**PRELIMINARY**  
NOT FOR CONSTRUCTION

S-9

**MISSION BEACH SEAWALL IMPROVEMENTS FEASIBILITY STUDY**

**TYPICAL BEACH ACCESS STAIR**

CITY OF SAN DIEGO, CALIFORNIA  
PUBLIC WORKS DEPARTMENT  
SHEET OF SHEETS

APPROVED:		DATE		SUBMITTED BY:	
FOR CITY ENGINEER		DATE		PROJECT MANAGER	
PRINT NAME		RCE#		CHECKED BY:	
DESCRIPTION	BY	APPROVED	DATE	FILMED	PROJECT ENGINEER
ORIGINAL	REC				CCS27 COORDINATE
					CCS83 COORDINATE

CONTRACTOR \_\_\_\_\_ DATE STARTED \_\_\_\_\_  
 INSPECTOR \_\_\_\_\_ DATE COMPLETED \_\_\_\_\_



FOR ITEMS NOT NOTED, SEE  $\frac{2}{S-11}$

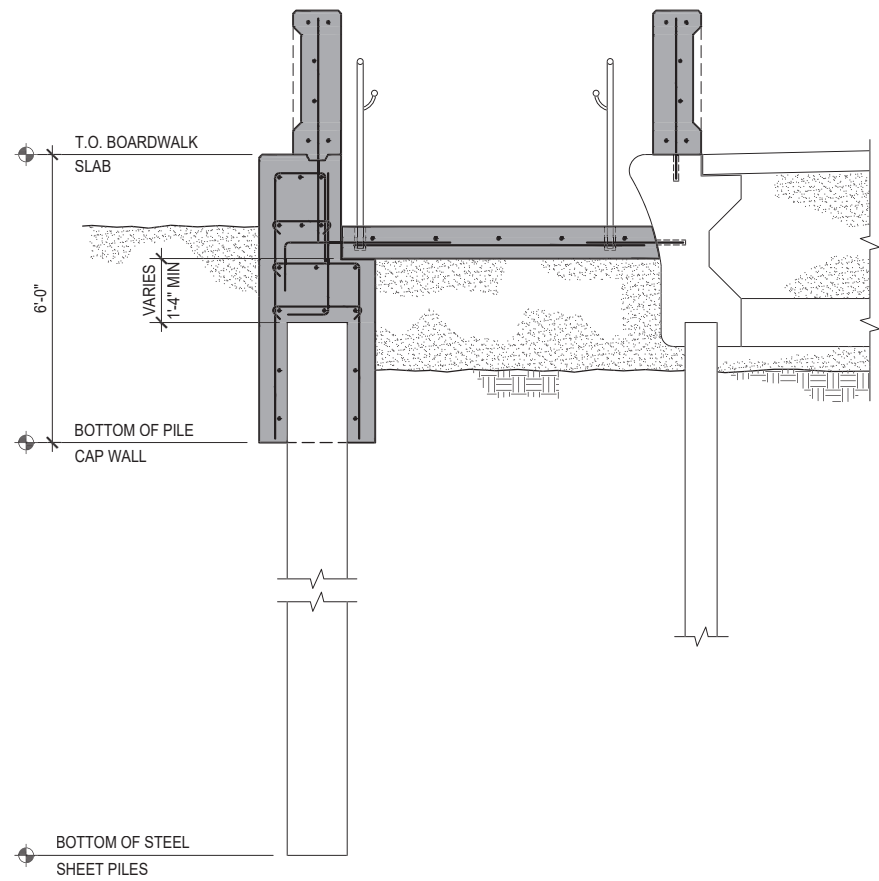

RAMP SECTION  
1/2" = 1'-0"

10

FOR ITEMS NOT NOTED, SEE  $\frac{2}{S-11}$

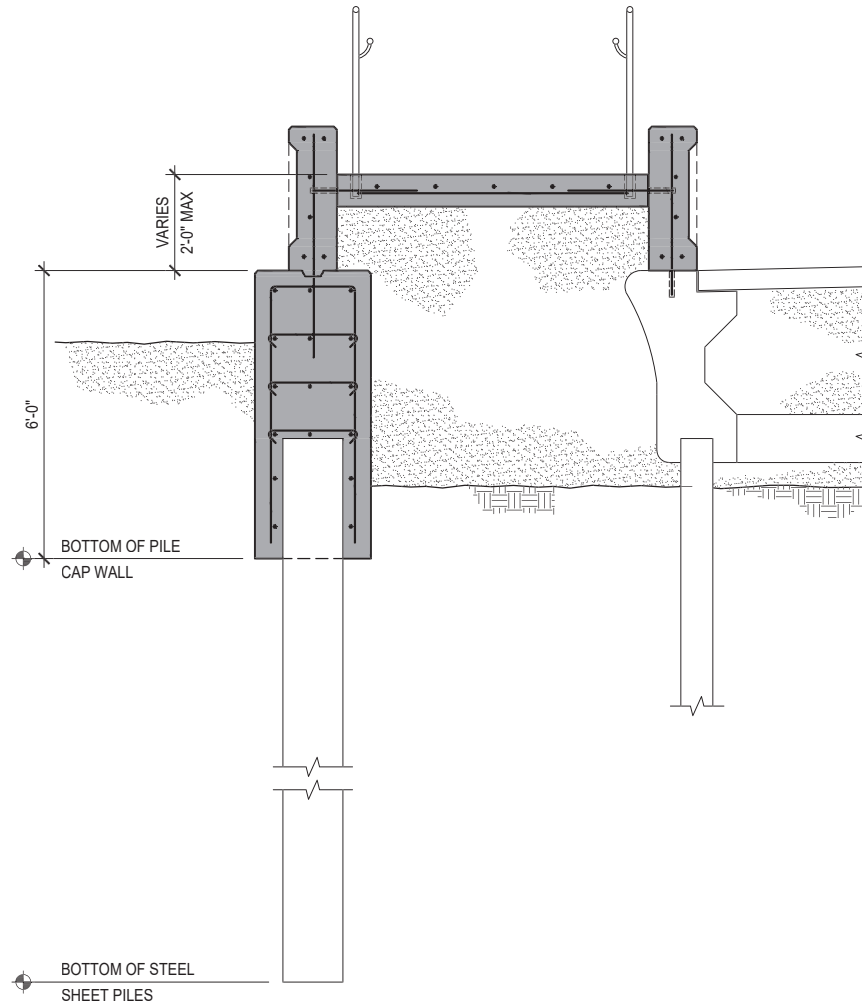

RAMP SECTION  
1/2" = 1'-0"

4

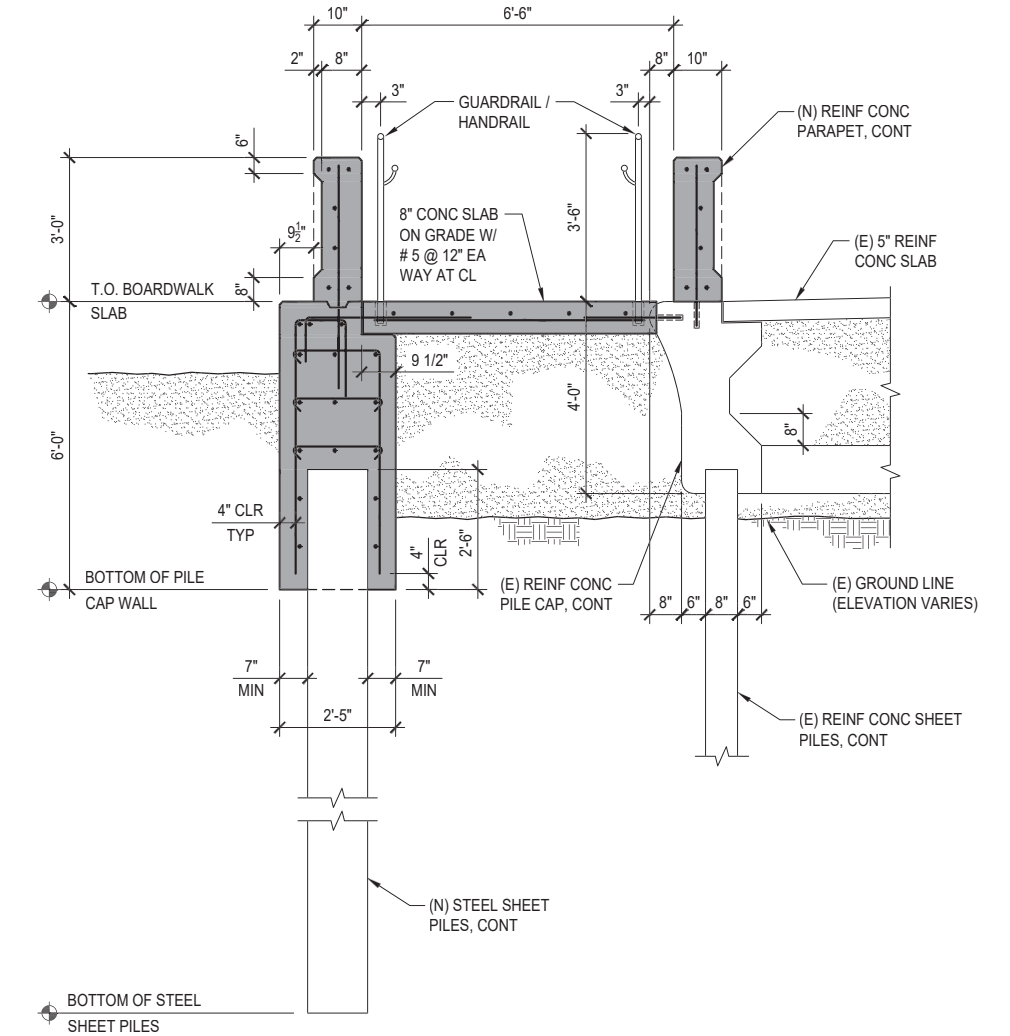

RAMP SECTION  
1/2" = 1'-0"

2

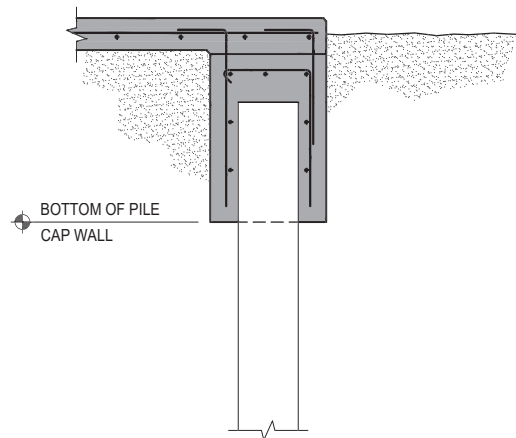

DETAIL  
1/2" = 1'-0"

8



PRELIMINARY  
NOT FOR CONSTRUCTION

S - 11

MISSION BEACH SEAWALL IMPROVEMENTS FEASIBILITY STUDY  
TYPICAL BEACH ACCESS RAMP  
DETAILS NO.1

CITY OF SAN DIEGO, CALIFORNIA  
PUBLIC WORKS DEPARTMENT  
SHEET OF SHEETS

APPROVED:	DATE	FOR CITY ENGINEER	PROJECT MANAGER
PRINT NAME	RCE#	CHECKED BY:	PROJECT ENGINEER
DESCRIPTION	BY	APPROVED	DATE
ORIGINAL	REC		

CONTRACTOR \_\_\_\_\_ DATE STARTED \_\_\_\_\_  
INSPECTOR \_\_\_\_\_ DATE COMPLETED \_\_\_\_\_

FILE NAME: J:\yada\proj\1707500 MISSION BEACH PARK IMPROVEMENTS\11.dwg  
PLOTTER: Monby, November 07, 2022 - 10:56am USER: roud

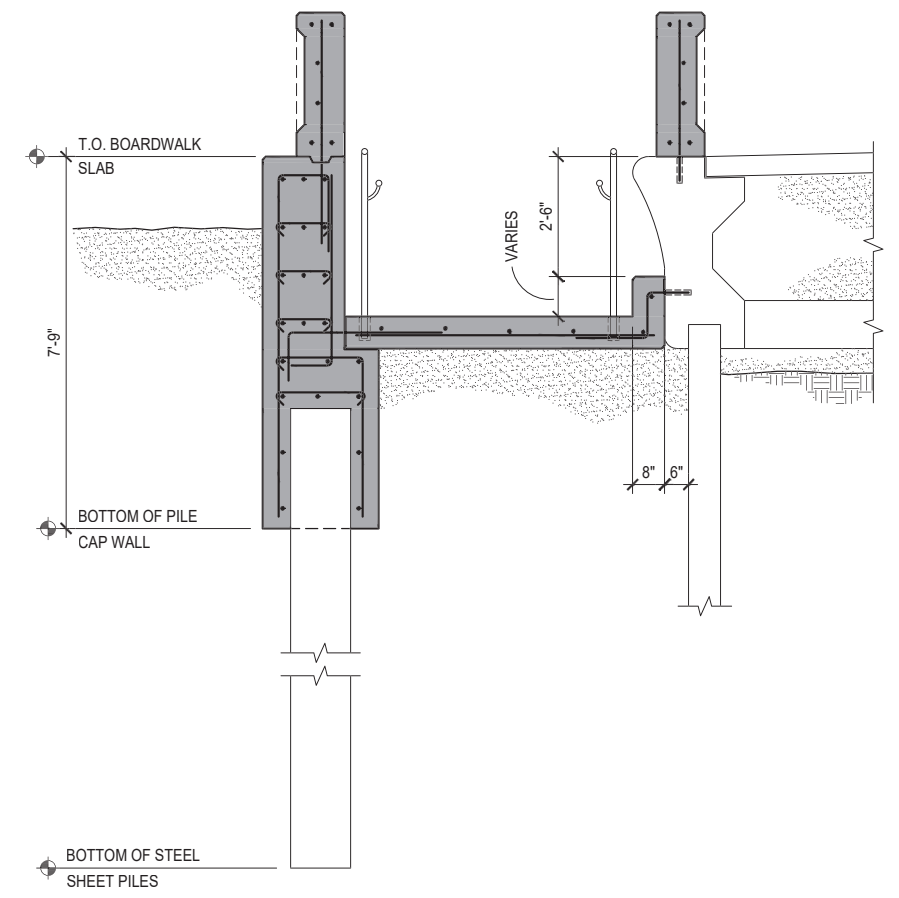

**RAMP SECTION**  
1/2" = 1'-0"



**PRELIMINARY**  
NOT FOR CONSTRUCTION

**S - 12**

**MISSION BEACH SEAWALL IMPROVEMENTS FEASIBILITY STUDY  
TYPICAL BEACH ACCESS RAMP  
DETAILS NO.2**

CITY OF SAN DIEGO, CALIFORNIA  
PUBLIC WORKS DEPARTMENT  
SHEET OF SHEETS

APPROVED:	DATE	FOR CITY ENGINEER	DATE
PRINT NAME	RCE#	PROJECT MANAGER	CHECKED BY:
DESCRIPTION	BY	APPROVED	DATE
ORIGINAL	REC		

CONTRACTOR \_\_\_\_\_ DATE STARTED \_\_\_\_\_  
INSPECTOR \_\_\_\_\_ DATE COMPLETED \_\_\_\_\_

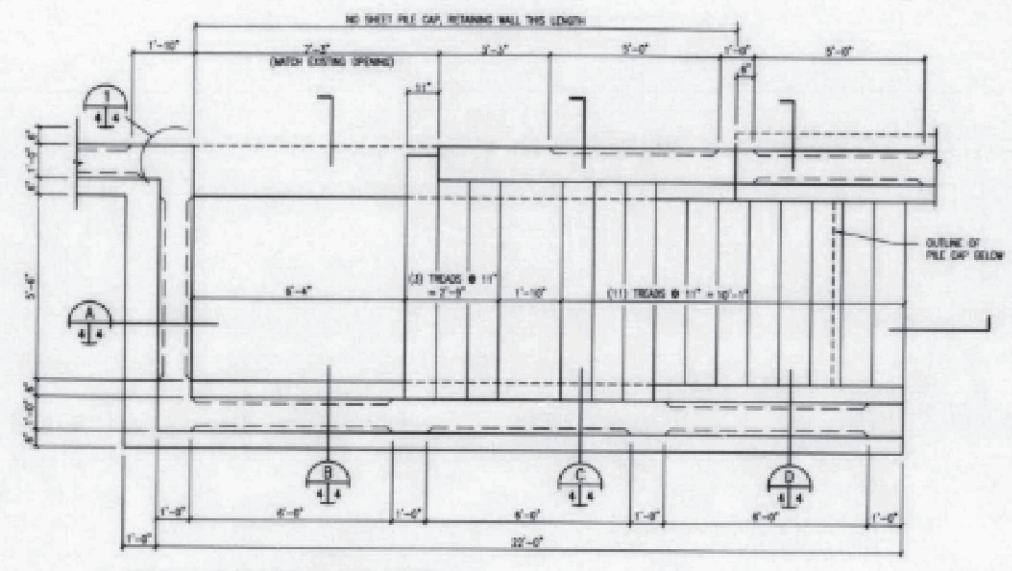

NOTE: VERIFY EXISTING STAIR LOCATION AND DIMENSION AND MATCH WITH NEW.

**STAIR PLAN (TYP. OF (2))**  
SCALE: 1/2" = 1'-0"

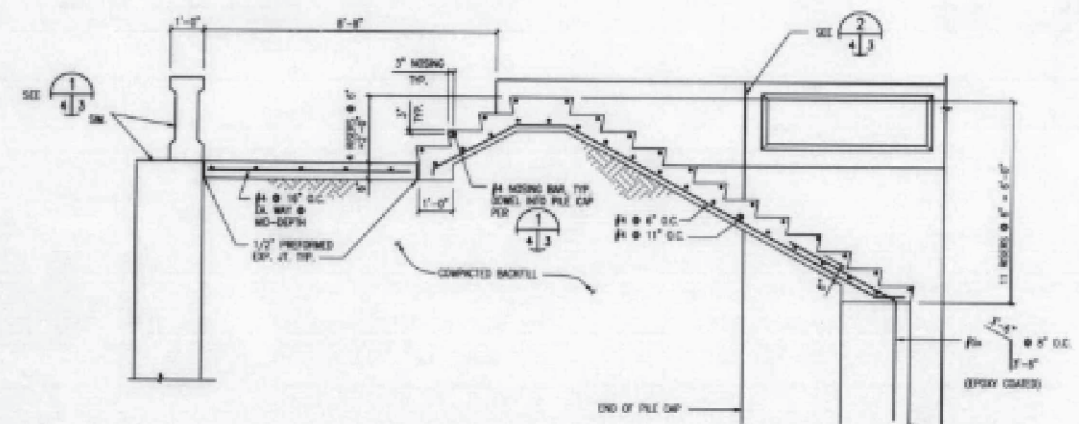

**SECTION**  
SCALE: 1/2" = 1'-0"

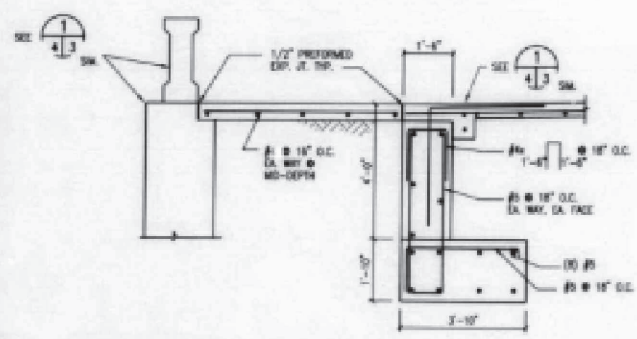

**SECTION**  
SCALE: 1/2" = 1'-0"

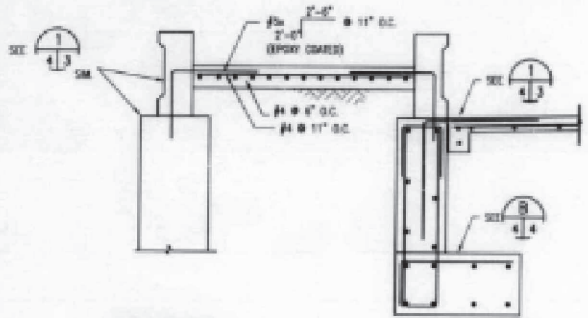

**SECTION**  
SCALE: 1/2" = 1'-0"

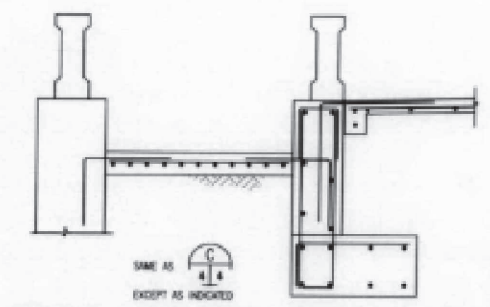

**SECTION**  
SCALE: 1/2" = 1'-0"

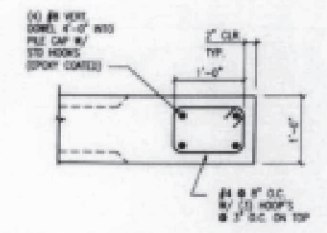

**DETAIL**  
SCALE: 1" = 1'-0"

CITY CONTRACT OF No. 52-328.5  
SPECIFICATION No. 7003

**OCEAN FRONT WALK REPLACEMENT  
BETWEEN THOMAS AVE. & PACIFIC BEACH DRIVE**

**STAIR PLAN AND SECTION**

CITY OF SAN DIEGO, CALIFORNIA ENGINEERING DEPARTMENT DESIGN & DRAWING	NO. 523385
DATE: 1-8-88	DATE: 1-8-88
BY: [Signature]	BY: [Signature]
CHECKED BY: [Signature]	CHECKED BY: [Signature]
APPROVED BY: [Signature]	APPROVED BY: [Signature]
DATE: 1-8-88	DATE: 1-8-88
PROJECT NO. 52-328.5	SHEET NO. 29213-4-D



**AS BUILT**

PRELIMINARY  
NOT FOR CONSTRUCTION

R-1

MISSION BEACH SEAWALL  
IMPROVEMENTS FEASIBILITY STUDY  
REFERENCE:  
EXISTING BEACH ACCESS STAIR

CITY OF SAN DIEGO, CALIFORNIA  
PUBLIC WORKS DEPARTMENT  
SHEET OF SHEETS

APPROVED:	DATE:	FOR CITY ENGINEER	DATE:
PRINT NAME:	RCE#:	PROJECT MANAGER	CHECKED BY:
DESCRIPTION:	BY:	APPROVED:	DATE:
ORIGINAL:	REC:	PROJECT ENGINEER	
		CCS27 COORDINATE	
		CCS83 COORDINATE	

CONTRACTOR: \_\_\_\_\_ DATE STARTED: \_\_\_\_\_  
INSPECTOR: \_\_\_\_\_ DATE COMPLETED: \_\_\_\_\_

## **C. Preliminary Opinion of Probable Construction Cost Estimate**

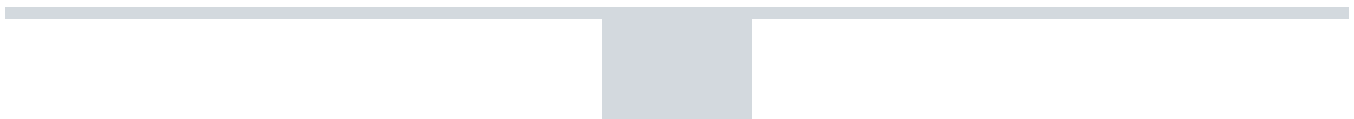

# City of San Diego

Mission Bay Seawall  
Segment A - Replace Parapet

## Opinion of Probable Construction Cost Summary

10/14/2022

### AACE Expected Accuracy Range

Bid Item	Description	Quantity	Unit	Unit Price	Construction Cost	Class 4 Estimate -20%	Class 4 Estimate +30%
1	Mobilization / Demobilization	1	LS	\$65,000	\$65,000		
2	Construction Fencing	18,400	LF	\$10.00	\$184,000		
3	Demolition	811	CY	\$930.00	\$754,230		
4	Concrete Wall	946	CY	\$3,105.00	\$2,937,330		
5	SWPP	1	LS	\$160,000	\$160,000		
Total					\$4,100,560		
Contingency @25%					\$1,025,140		
Total Preliminary Cost Estimate					\$5,125,700	\$4,100,560	\$6,663,410
For Budgeting					\$5,126,000		

#### Notes:

- 1 Costs are in 2022 USD
- 2 Costs assume work is performed from the beach side of the seawall and approximately 1,000 ft sections of beach will be fenced off approx 30 feet from the seawall
- 3 Approximately half of the boardwalk will be fenced off in addition to the approx. 30' width of beach adjacent to the seawall to keep the public out of the work area
- 4 Quantities are based off drawing set from 2022-10-10 progress set
- 5 Costs assume an 8 hour per day, five days per week work schedule
- 6 Costs assume existing concrete parapet wall will be hauled to a landfill
- 7 It is assumed that the concrete debris can be stockpiled onsite and hauled off once or twice weekly instead of daily
- 8 No allowance has been made for the contractor to move their equipment to an offsite staging area overnight
- 9 Costs assumed the contractor will construct access points where street access to the boardwalk is available
- 10 Construction duration is estimated at 11.0 months

# City of San Diego

Mission Bay Seawall  
Segment A - Void Repairs

## Opinion of Probable Construction Cost Summary

10/14/2022

### AACE Expected Accuracy Range

Bid Item	Description	Quantity	Unit	Unit Price	Construction Cost	Class 4 Estimate -20%	Class 4 Estimate +30%
1	Mobilization / Demobilization	1	LS	\$40,000	\$40,000		
2	Construction Fencing	1	LS	\$50,000	\$50,000		
3	Void Repairs	1,000	CY	\$325.00	\$325,000		
5	SWPP	1	LS	\$50,000	\$50,000		
Total					\$465,000		
Contingency @25%					\$116,250		
Total Preliminary Cost Estimate					\$581,250	\$465,000	\$755,625
For Budgeting					\$582,000		

Notes:

- 1 Costs are in 2022 USD
- 2 Quantities are based off drawing set from 2022-10-10 progress set
- 3 Costs assume an 8 hour per day, five days per week work schedule
- 4 No allowance has been made for the contractor to move their equipment to an offsite staging area overnight
- 5 Costs assumed the contractor will construct access points where street access to the boardwalk is available
- 6 Construction duration is estimated at 3.0 months

# City of San Diego

Mission Bay Seawall  
Segment A - Void Repairs

Opinion of Probable Construction Cost Summary

10/14/2022

## AACE Expected Accuracy Range

Bid Item	Description	Quantity	Unit	Unit Price	Construction Cost	Class 4 Estimate -20%	Class 4 Estimate +30%
1	Mobilization / Demobilization	1	LS	\$40,000	\$40,000		
2	Construction Fencing	1	LS	\$50,000	\$50,000		
3	Void Repairs	1,000	CY	\$325.00	\$325,000		
5	SWPP	1	LS	\$50,000	\$50,000		
Total					\$465,000		
Contingency @25%					\$116,250		
Total Preliminary Cost Estimate					\$581,250	\$465,000	\$755,625
For Budgeting					\$582,000		

Notes:

- 1 Costs are in 2022 USD
- 2 Quantities are based off drawing set from 2022-10-10 progress set
- 3 Costs assume an 8 hour per day, five days per week work schedule
- 4 No allowance has been made for the contractor to move their equipment to an offsite staging area overnight
- 5 Costs assumed the contractor will construct access points where street access to the boardwalk is available
- 6 Construction duration is estimated at 3.0 months

# City of San Diego

Mission Bay Seawall  
 Segment A - Option 2 - Raise Boardwalk  
 Opinion of Probable Construction Cost Summary

10/14/2022

## AACE Expected Accuracy Range

Bid Item	Description	Quantity	Unit	Unit Price	Construction Cost	Class 4 Estimate -20%	Class 4 Estimate +30%
1	Mobilization / Demobilization	1	LS	\$65,000	\$65,000		
2	Construction Fencing	18,400	LF	\$10.00	\$184,000		
3	Demolition	3,960	CY	\$540.00	\$2,138,400		
4	Concrete Wall	7,045	CY	\$1,715.00	\$12,082,175		
5	SWPP	1	LS	\$210,000	\$210,000		
Total					\$14,679,575		
Contingency @25%					\$3,669,894		
Total Preliminary Cost Estimate					\$18,349,469	\$14,679,575	\$23,854,309
For Budgeting					\$18,350,000		

Notes:

- 1 Costs are in 2022 USD
- 2 Costs assume work is performed from the beach side of the seawall and approximately 1,000 ft sections of beach will be fenced off approx 30 feet from the seawall
- 3 Approximately half of the boardwalk will be fenced off in addition to the approx. 30' width of beach adjacent to the seawall to keep the public out of the work area
- 4 Quantities are based off drawing set from 2022-10-10 progress set
- 5 Costs assume an 8 hour per day, five days per week work schedule
- 6 Costs assume existing concrete parapet wall, and existing sidewalk that is to be demo'd, will be hauled to a landfill
- 7 It is assumed that the concrete debris can be stockpiled onsite and hauled off once or twice weekly instead of daily
- 8 No allowance has been made for the contractor to move their equipment to an offsite staging area overnight
- 9 Costs assumed the contractor will construct access points where street access to the boardwalk is available
- 10 Construction duration is estimated at 25.0 months

# City of San Diego

Mission Bay Seawall  
Segment B - Replace Parapet

Opinion of Probable Construction Cost Summary

10/14/2022

## AACE Expected Accuracy Range

Bid Item	Description	Quantity	Unit	Unit Price	Construction Cost	Class 4 Estimate -20%	Class 4 Estimate +30%
1	Mobilization / Demobilization	1	LS	\$65,000	\$65,000		
2	Construction Fencing	2,120	LF	\$10.00	\$21,200		
3	Demolition	100	CY	\$930.00	\$93,000		
4	Concrete Wall	110	CY	\$3,105.00	\$341,550		
5	SWPP	1	LS	\$20,000	\$20,000		
Total					\$540,750		
Contingency @25%					\$135,188		
Total Preliminary Cost Estimate					\$675,938	\$540,750	\$878,719
For Budgeting					\$676,000		

Notes:

- 1 Costs are in 2022 USD
- 2 Costs assume work is performed from the beach side of the seawall and approximately 1,000 ft sections of beach will be fenced off approx 30 feet from the seawall
- 3 Approximately half of the boardwalk will be fenced off in addition to the approx. 30' width of beach adjacent to the seawall to keep the public out of the work area
- 4 Quantities are based off drawing set from 2022-10-10 progress set
- 5 Costs assume an 8 hour per day, five days per week work schedule
- 6 Costs assume existing concrete parapet wall will be hauled to a landfill
- 7 It is assumed that the concrete debris can be stockpiled onsite and hauled off once or twice weekly instead of daily
- 8 No allowance has been made for the contractor to move their equipment to an offsite staging area overnight
- 9 Costs assumed the contractor will construct access points where street access to the boardwalk is available
- 10 Construction duration is estimated at 2.5 months

# City of San Diego

Mission Bay Seawall  
 Segment C - Option 1 - New Seawall  
 Opinion of Probable Construction Cost Summary

10/14/2022

## AACE Expected Accuracy Range

Bid Item	Description	Quantity	Unit	Unit Price	Construction Cost	Class 4 Estimate -20%	Class 4 Estimate +30%
1	Mobilization / Demobilization	1	LS	\$65,000	\$65,000		
2	Construction Fencing	840	LF	\$10.00	\$8,400		
3	Demolition	91	CY	\$610.00	\$55,510		
4	Sheet pile Wall	375	LF	\$1,020.00	\$382,500		
5	Concrete Wall/Cap	173	CY	\$2,160.00	\$373,680		
6	Concrete Sidewalk/Slab	125	CY	\$1,610.00	\$201,250		
7	SWPP	1	LS	\$30,000	\$30,000		
Total					\$1,116,340		
Contingency @25%					\$279,085		
Total Preliminary Cost Estimate					\$1,395,425	\$1,116,340	\$1,814,053
For Budgeting					\$1,396,000		

Notes:

- 1 Costs are in 2022 USD
- 2 Costs assume work is performed from the beach side of the seawall and approximately 1,000 ft sections of beach will be fenced off approx 30 feet from the seawall
- 3 Approximately half of the boardwalk will be fenced off in addition to the approx. 30' width of beach adjacent to the seawall to keep the public out of the work area
- 4 Quantities are based off drawing set from 2022-10-10 progress set
- 5 Costs assume an 8 hour per day, five days per week work schedule
- 6 Costs assume existing sidewalk that is to be demo, will be hauled to a landfill
- 7 It is assumed that the concrete debris can be stockpiled onsite and hauled off once or twice weekly instead of daily
- 8 No allowance has been made for the contractor to move their equipment to an offsite staging area overnight
- 9 Costs assumed the contractor will construct access points where street access to the boardwalk is available
- 10 Construction duration is estimated at 3.5 months

# City of San Diego

Mission Bay Seawall  
 Segment C - Option 2 - Decorative Seawall  
 Opinion of Probable Construction Cost Summary

10/14/2022

## AACE Expected Accuracy Range

Bid Item	Description	Quantity	Unit	Unit Price	Construction Cost	Class 4 Estimate -20%	Class 4 Estimate +30%
1	Mobilization / Demobilization	1	LS	\$65,000	\$65,000		
2	Construction Fencing	840	LF	\$10.00	\$8,400		
3	Demolition	91	CY	\$610.00	\$55,510		
4	Concrete Decorative Wall	147	CY	\$2,580.00	\$379,260		
5	Concrete Sidewalk	125	CY	\$1,610.00	\$201,250		
6	SWPP	1	LS	\$30,000	\$30,000		
Total					\$739,420		
Contingency @25%					\$184,855		
Total Preliminary Cost Estimate					\$924,275	\$739,420	\$1,201,558
For Budgeting					\$925,000		

Notes:

- 1 Costs are in 2022 USD
- 2 Costs assume work is performed from the beach side of the seawall and approximately 1,000 ft sections of beach will be fenced off approx 30 feet from the seawall
- 3 Approximately half of the boardwalk will be fenced off in addition to the approx. 30' width of beach adjacent to the seawall to keep the public out of the work area
- 4 Quantities are based off drawing set from 2022-10-10 progress set
- 5 Costs assume an 8 hour per day, five days per week work schedule
- 6 Costs assume existing sidewalk that is to be demo, will be hauled to a landfill
- 7 It is assumed that the concrete debris can be stockpiled onsite and hauled off once or twice weekly instead of daily
- 8 No allowance has been made for the contractor to move their equipment to an offsite staging area overnight
- 9 Costs assumed the contractor will construct access points where street access to the boardwalk is available
- 10 Construction duration is estimated at 3.0 months

# City of San Diego

Mission Bay Seawall  
 Beach Access Stairs (cost per stairway)  
 Opinion of Probable Construction Cost Summary

10/14/2022

## AACE Expected Accuracy Range

Bid Item	Description	Quantity	Unit	Unit Price	Construction Cost	Class 4 Estimate -20%	Class 4 Estimate +30%
1	Mobilization / Demobilization	1	LS	\$25,000	\$25,000		
2	Construction Fencing	200	LF	\$10.00	\$2,000		
3	Beach Access Stairs	1	EACH	\$70,000.00	\$70,000		
4	SWPP	1	LS	\$10,000	\$10,000		
Total					\$107,000		
Contingency @25%					\$26,750		
Total Preliminary Cost Estimate					\$133,750	\$107,000	\$173,875
For Budgeting					\$134,000		

Notes:

- 1 Costs are in 2022 USD
- 2 Costs assume work is performed from the beach side of the seawall and section of beach will be fenced off approx 30 feet from the seawall
- 3 Approximately half of the boardwalk will be fenced off in addition to the approx. 30' width of beach adjacent to the seawall to keep the public out of the work area
- 4 Quantities are based off drawing set from 2022-10-10 progress set
- 5 Costs assume an 8 hour per day, five days per week work schedule
- 6 No allowance has been made for the contractor to move their equipment to an offsite staging area overnight
- 7 Costs assumed the contractor will construct access points where street access to the boardwalk is available
- 8 Construction duration is estimated at 2.0 weeks per stairway

# City of San Diego

Mission Bay Seawall  
 ADA Pedestrian Ramp (cost per ramp)  
 Opinion of Probable Construction Cost Summary

10/14/2022

## AACE Expected Accuracy Range

Bid Item	Description	Quantity	Unit	Unit Price	Construction Cost	Class 4 Estimate -20%	Class 4 Estimate +30%
1	Mobilization / Demobilization	1	LS	\$25,000	\$25,000		
2	Construction Fencing	400	LF	\$10.00	\$4,000		
4	Beach Access ADA Ramp	1	EACH	\$535,000.00	\$535,000		
5	SWPP	1	LS	\$10,000	\$10,000		
Total					\$574,000		
Contingency @25%					\$143,500		
Total Preliminary Cost Estimate					\$717,500	\$574,000	\$932,750
For Budgeting					\$718,000		

Notes:

- 1 Costs are in 2022 USD
- 2 Costs assume work is performed from the beach side of the seawall and section of beach will be fenced off approx 30 feet from the seawall
- 3 Approximately half of the boardwalk will be fenced off in addition to the approx. 30' width of beach adjacent to the seawall to keep the public out of the work area
- 4 Quantities are based off drawing set from 2022-10-10 progress set
- 5 Costs assume an 8 hour per day, five days per week work schedule
- 6 No allowance has been made for the contractor to move their equipment to an offsite staging area overnight
- 7 Costs assumed the contractor will construct access points where street access to the boardwalk is available
- 8 Construction duration is estimated at 1.0 months

# City of San Diego

Mission Bay Seawall  
Driveway Construction

## Opinion of Probable Construction Cost Summary

10/14/2022

### AACE Expected Accuracy Range

Bid Item	Description	Quantity	Unit	Unit Price	Construction Cost	Class 4 Estimate -20%	Class 4 Estimate +30%
1	Mobilization / Demobilization	1	LS	\$25,000	\$25,000		
2	Construction Fencing	300	LF	\$10.00	\$3,000		
4	Driveway	1	EACH	\$360,000.00	\$360,000		
5	SWPP	1	LS	\$10,000	\$10,000		
Total					\$398,000		
Contingency @25%					\$99,500		
Total Preliminary Cost Estimate					\$497,500	\$398,000	\$646,750
For Budgeting					\$498,000		

Notes:

- 1 Costs are in 2022 USD
- 2 Costs assume work is performed from the beach side of the seawall and section of beach will be fenced off approx 30 feet from the seawall
- 3 Approximately half of the boardwalk will be fenced off in addition to the approx. 30' width of beach adjacent to the seawall to keep the public out of the work area
- 4 Quantities are based off drawing set from 2022-10-10 progress set
- 5 Costs assume an 8 hour per day, five days per week work schedule
- 6 No allowance has been made for the contractor to move their equipment to an offsite staging area overnight
- 7 Costs assumed the contractor will construct access points where street access to the boardwalk is available
- 8 Construction duration is estimated at 1.0 months

# City of San Diego

Mission Bay Seawall  
Segment A - Option 2 - Raise Boardwalk  
Opinion of Probable Construction Cost Summary

10/14/2022

## AACE Expected Accuracy Range

Bid Item	Description	Quantity	Unit	Unit Price	Construction Cost	Class 4 Estimate -20%	Class 4 Estimate +30%
1	Mobilization / Demobilization	1	LS	\$65,000	\$65,000		
2	Construction Fencing	18,400	LF	\$10.00	\$184,000		
3	Demolition	3,960	CY	\$540.00	\$2,138,400		
4	Concrete Wall	7,045	CY	\$1,715.00	\$12,082,175		
5	SWPP	1	LS	\$210,000	\$210,000		
Total					\$14,679,575		
Contingency @25%					\$3,669,894		
Total Preliminary Cost Estimate					\$18,349,469	\$14,679,575	\$23,854,309
For Budgeting					\$18,350,000		

Notes:

- 1 Costs are in 2022 USD
- 2 Costs assume work is performed from the beach side of the seawall and approximately 1,000 ft sections of beach will be fenced off approx 30 feet from the seawall
- 3 Approximately half of the boardwalk will be fenced off in addition to the approx. 30' width of beach adjacent to the seawall to keep the public out of the work area
- 4 Quantities are based off drawing set from 2022-10-10 progress set
- 5 Costs assume an 8 hour per day, five days per week work schedule
- 6 Costs assume existing concrete parapet wall, and existing sidewalk that is to be demo'd, will be hauled to a landfill
- 7 It is assumed that the concrete debris can be stockpiled onsite and hauled off once or twice weekly instead of daily
- 8 No allowance has been made for the contractor to move their equipment to an offsite staging area overnight
- 9 Costs assumed the contractor will construct access points where street access to the boardwalk is available
- 10 Construction duration is estimated at 25.0 months

# City of San Diego

Mission Bay Seawall  
Segment B - Replace Parapet

Opinion of Probable Construction Cost Summary

10/14/2022

## AACE Expected Accuracy Range

Bid Item	Description	Quantity	Unit	Unit Price	Construction Cost	Class 4 Estimate -20%	Class 4 Estimate +30%
1	Mobilization / Demobilization	1	LS	\$65,000	\$65,000		
2	Construction Fencing	2,120	LF	\$10.00	\$21,200		
3	Demolition	100	CY	\$930.00	\$93,000		
4	Concrete Wall	110	CY	\$3,105.00	\$341,550		
5	SWPP	1	LS	\$20,000	\$20,000		
Total					\$540,750		
Contingency @25%					\$135,188		
Total Preliminary Cost Estimate					\$675,938	\$540,750	\$878,719
For Budgeting					\$676,000		

Notes:

- 1 Costs are in 2022 USD
- 2 Costs assume work is performed from the beach side of the seawall and approximately 1,000 ft sections of beach will be fenced off approx 30 feet from the seawall
- 3 Approximately half of the boardwalk will be fenced off in addition to the approx. 30' width of beach adjacent to the seawall to keep the public out of the work area
- 4 Quantities are based off drawing set from 2022-10-10 progress set
- 5 Costs assume an 8 hour per day, five days per week work schedule
- 6 Costs assume existing concrete parapet wall will be hauled to a landfill
- 7 It is assumed that the concrete debris can be stockpiled onsite and hauled off once or twice weekly instead of daily
- 8 No allowance has been made for the contractor to move their equipment to an offsite staging area overnight
- 9 Costs assumed the contractor will construct access points where street access to the boardwalk is available
- 10 Construction duration is estimated at 2.5 months

# City of San Diego

Mission Bay Seawall  
 Segment C - Option 1 - New Seawall  
 Opinion of Probable Construction Cost Summary

10/14/2022

## AACE Expected Accuracy Range

Bid Item	Description	Quantity	Unit	Unit Price	Construction Cost	Class 4 Estimate -20%	Class 4 Estimate +30%
1	Mobilization / Demobilization	1	LS	\$65,000	\$65,000		
2	Construction Fencing	840	LF	\$10.00	\$8,400		
3	Demolition	91	CY	\$610.00	\$55,510		
4	Sheet pile Wall	375	LF	\$1,020.00	\$382,500		
5	Concrete Wall/Cap	173	CY	\$2,160.00	\$373,680		
6	Concrete Sidewalk/Slab	125	CY	\$1,610.00	\$201,250		
7	SWPP	1	LS	\$30,000	\$30,000		
Total					\$1,116,340		
Contingency @25%					\$279,085		
Total Preliminary Cost Estimate					\$1,395,425	\$1,116,340	\$1,814,053
For Budgeting					\$1,396,000		

Notes:

- 1 Costs are in 2022 USD
- 2 Costs assume work is performed from the beach side of the seawall and approximately 1,000 ft sections of beach will be fenced off approx 30 feet from the seawall
- 3 Approximately half of the boardwalk will be fenced off in addition to the approx. 30' width of beach adjacent to the seawall to keep the public out of the work area
- 4 Quantities are based off drawing set from 2022-10-10 progress set
- 5 Costs assume an 8 hour per day, five days per week work schedule
- 6 Costs assume existing sidewalk that is to be demo, will be hauled to a landfill
- 7 It is assumed that the concrete debris can be stockpiled onsite and hauled off once or twice weekly instead of daily
- 8 No allowance has been made for the contractor to move their equipment to an offsite staging area overnight
- 9 Costs assumed the contractor will construct access points where street access to the boardwalk is available
- 10 Construction duration is estimated at 3.5 months

# City of San Diego

Mission Bay Seawall  
 Segment C - Option 2 - Decorative Seawall  
 Opinion of Probable Construction Cost Summary

10/14/2022

## AACE Expected Accuracy Range

Bid Item	Description	Quantity	Unit	Unit Price	Construction Cost	Class 4 Estimate -20%	Class 4 Estimate +30%
1	Mobilization / Demobilization	1	LS	\$65,000	\$65,000		
2	Construction Fencing	840	LF	\$10.00	\$8,400		
3	Demolition	91	CY	\$610.00	\$55,510		
4	Concrete Decorative Wall	147	CY	\$2,580.00	\$379,260		
5	Concrete Sidewalk	125	CY	\$1,610.00	\$201,250		
6	SWPP	1	LS	\$30,000	\$30,000		
Total					\$739,420		
Contingency @25%					\$184,855		
Total Preliminary Cost Estimate					\$924,275	\$739,420	\$1,201,558
For Budgeting					\$925,000		

Notes:

- 1 Costs are in 2022 USD
- 2 Costs assume work is performed from the beach side of the seawall and approximately 1,000 ft sections of beach will be fenced off approx 30 feet from the seawall
- 3 Approximately half of the boardwalk will be fenced off in addition to the approx. 30' width of beach adjacent to the seawall to keep the public out of the work area
- 4 Quantities are based off drawing set from 2022-10-10 progress set
- 5 Costs assume an 8 hour per day, five days per week work schedule
- 6 Costs assume existing sidewalk that is to be demo, will be hauled to a landfill
- 7 It is assumed that the concrete debris can be stockpiled onsite and hauled off once or twice weekly instead of daily
- 8 No allowance has been made for the contractor to move their equipment to an offsite staging area overnight
- 9 Costs assumed the contractor will construct access points where street access to the boardwalk is available
- 10 Construction duration is estimated at 3.0 months

# City of San Diego

Mission Bay Seawall  
 Beach Access Stairs (cost per stairway)  
 Opinion of Probable Construction Cost Summary

10/14/2022

## AACE Expected Accuracy Range

Bid Item	Description	Quantity	Unit	Unit Price	Construction Cost	Class 4 Estimate -20%	Class 4 Estimate +30%
1	Mobilization / Demobilization	1	LS	\$25,000	\$25,000		
2	Construction Fencing	200	LF	\$10.00	\$2,000		
3	Beach Access Stairs	1	EACH	\$70,000.00	\$70,000		
4	SWPP	1	LS	\$10,000	\$10,000		
Total					\$107,000		
Contingency @25%					\$26,750		
Total Preliminary Cost Estimate					\$133,750	\$107,000	\$173,875
For Budgeting					\$134,000		

Notes:

- 1 Costs are in 2022 USD
- 2 Costs assume work is performed from the beach side of the seawall and section of beach will be fenced off approx 30 feet from the seawall
- 3 Approximately half of the boardwalk will be fenced off in addition to the approx. 30' width of beach adjacent to the seawall to keep the public out of the work area
- 4 Quantities are based off drawing set from 2022-10-10 progress set
- 5 Costs assume an 8 hour per day, five days per week work schedule
- 6 No allowance has been made for the contractor to move their equipment to an offsite staging area overnight
- 7 Costs assumed the contractor will construct access points where street access to the boardwalk is available
- 8 Construction duration is estimated at 2.0 weeks per stairway

# City of San Diego

Mission Bay Seawall  
 ADA Pedestrian Ramp (cost per ramp)  
 Opinion of Probable Construction Cost Summary

10/14/2022

## AACE Expected Accuracy Range

Bid Item	Description	Quantity	Unit	Unit Price	Construction Cost	Class 4 Estimate -20%	Class 4 Estimate +30%
1	Mobilization / Demobilization	1	LS	\$25,000	\$25,000		
2	Construction Fencing	400	LF	\$10.00	\$4,000		
4	Beach Access ADA Ramp	1	EACH	\$535,000.00	\$535,000		
5	SWPP	1	LS	\$10,000	\$10,000		
Total					\$574,000		
Contingency @25%					\$143,500		
Total Preliminary Cost Estimate					\$717,500	\$574,000	\$932,750
For Budgeting					\$718,000		

Notes:

- 1 Costs are in 2022 USD
- 2 Costs assume work is performed from the beach side of the seawall and section of beach will be fenced off approx 30 feet from the seawall
- 3 Approximately half of the boardwalk will be fenced off in addition to the approx. 30' width of beach adjacent to the seawall to keep the public out of the work area
- 4 Quantities are based off drawing set from 2022-10-10 progress set
- 5 Costs assume an 8 hour per day, five days per week work schedule
- 6 No allowance has been made for the contractor to move their equipment to an offsite staging area overnight
- 7 Costs assumed the contractor will construct access points where street access to the boardwalk is available
- 8 Construction duration is estimated at 1.0 months

# City of San Diego

Mission Bay Seawall  
Driveway Construction

## Opinion of Probable Construction Cost Summary

10/14/2022

### AACE Expected Accuracy Range

Bid Item	Description	Quantity	Unit	Unit Price	Construction Cost	Class 4 Estimate -20%	Class 4 Estimate +30%
1	Mobilization / Demobilization	1	LS	\$25,000	\$25,000		
2	Construction Fencing	300	LF	\$10.00	\$3,000		
4	Driveway	1	EACH	\$360,000.00	\$360,000		
5	SWPP	1	LS	\$10,000	\$10,000		
Total					\$398,000		
Contingency @25%					\$99,500		
Total Preliminary Cost Estimate					\$497,500	\$398,000	\$646,750
For Budgeting					\$498,000		

Notes:

- 1 Costs are in 2022 USD
- 2 Costs assume work is performed from the beach side of the seawall and section of beach will be fenced off approx 30 feet from the seawall
- 3 Approximately half of the boardwalk will be fenced off in addition to the approx. 30' width of beach adjacent to the seawall to keep the public out of the work area
- 4 Quantities are based off drawing set from 2022-10-10 progress set
- 5 Costs assume an 8 hour per day, five days per week work schedule
- 6 No allowance has been made for the contractor to move their equipment to an offsite staging area overnight
- 7 Costs assumed the contractor will construct access points where street access to the boardwalk is available
- 8 Construction duration is estimated at 1.0 months

## **D. Risk Assessment Table**



RISK ASSESSMENT TABLE			Project Name: <b>Mission Beach Seawall Improvement Study</b>					
Risk Description			Risk Assessment			Risk Response		
ID #	Category	Title	Risk Statement	Probability	Cost Impact	Time Impact	Strategy	Response Actions
1	Land Ownership	Project potential to cross jurisdictional boundaries	The boardwalk and seawall sites are located within Mission Beach, in San Diego, CA, and are owned and maintained by the City of San Diego. As such, there are no known land ownership conflicts that may present risk to this project.	Very Low	Very Low	Very low	Permit	Permit project through necessary resource agencies, including California Coastal Commission, State Lands Commission, Regional Water Quality Control Board, and U.S. Army Corps of Engineers to ensure no conflict of land ownership.
2	Utilities	Existing electrical, gas, water, storm drain and telecommunication utilities	A preliminary review of utility data shows that utilities run through the Mission Beach neighborhood but there are no known conflicts with the project. A thorough field survey has not been performed to identify existing utilities. A more thorough utility survey should be done prior to final engineering.	Low	Moderate	Low	Mitigate	The contractor will be required to take due precautionary measures to protect any existing utilities or structures located at the work site. It is the contractor's responsibility to contact the owners of sewer, gas and electric, water, and storm drain outfall utilities or structures prior to any excavation for verification and location of utilities and notification of commencement of work.
3	Existing Soil Data	Soil physical composition, stratification, potential chemical contamination, and geotechnical characteristics.	Soil investigations were performed for the sites in 2018 and 2019. Most of the seawall is located along a geologic region described as having a low risk to geologic hazards. West of the seawall is described as "generally stable broad beach areas. The southern reach of the seawall from Coronado Court to Balboa Court, approximately 750 linear ft, is found to have a high potential for liquefaction. Liquefaction may be triggered by seismic activity and the resultant ground shaking (TerraCosta Consulting Group, 2019).	Low	Low	Low	Mitigate	<ul style="list-style-type: none"> <li>•There are no geologic hazards that cannot be avoided or addressed.</li> <li>•There are no policies or recommendations of the Mission Bay Park Master Plan Update which will have a direct or indirect significant environmental effect with regard to geologic hazards.</li> <li>•The proposed land uses are compatible with the known geologic hazards.</li> <li>•There are no potential impacts related to geologic hazards from the implementation of the Mission Bay Park Improvement Projects that can't be avoided, reduced to an acceptable level of risk, or reduced below a level of significance through mandatory conformance with applicable regulatory requirements and the recommendations of this technical report.</li> <li>• The impact of unstable soil can be reduced to less than significant levels by requiring geotechnical investigations on settlement sensitive projects (culverts, bridges, bulkheads and areas where substantial amounts of fill may be placed).</li> </ul>

RISK ASSESSMENT TABLE			Project Name: <b>Mission Beach Seawall Improvement Study</b>					
Risk Description			Risk Assessment			Risk Response		
ID #	Category	Title	Risk Statement	Probability	Cost Impact	Time Impact	Strategy	Response Actions
4	Proximity to Neighbors	Adjacent land uses which may be impacted by the project	The boardwalk and seawall improvement sites are located along most of Mission Beach. Moderate risks are present, including potential traffic and noise impacts during construction, especially to nearby residential neighbors and parks (e.g., Belmont Park). Improvements in front of Belmont Park are already completed however. Construction of the improvement sites will temporarily limit public access at all sites, with the exception of Belmont Park. However, long-term improvements to public access will result from project improvements.	Moderate	Low	High	Mitigate	Noise and traffic regulation may be necessary to restrict daily work hours and weekend work. Construction timing of the Project may be scheduled to reduce impacts to visitor use. Peak visitor use spans approximately from Memorial Day (May) through Labor Day (September). Project construction is anticipated to occur from post-Labor Day to February 15th. The risk associated with project controversy will be mitigated by involving the public in the development of the project, performing segments of the improvements in phases, and minimizing all negative project impacts.
5	Environmental Windows	Rare or endangered fish/wildlife present, and nesting or roosting migratory birds	There are no known presence of threatened or endangered birds to occur within the proposed improvements areas.	Low	Low	Low	Mitigate	Should impacts require mitigation, nesting restrictions are imposed from February 15th to September 1st (with some flexibility on the end date for certain bird species). No such restrictions are expected for this project however.
6	Water Quality Concerns	Temporary or permanent water quality impacts	Work for this project will not be done in the water. It will take place along the dry back beach and there are no drainage pathways to water bodies. Hence, no water quality concerns are anticipated for this project.	Low	Low	Low	Mitigate	Construction is expected to take place in dry conditions and should not produce water quality impacts. Nonetheless, the contractor will be required to provide a SWPPP for each improvement area of the project.
7	Competing Interests	City and public land use goals of the project area	The project is identified by the City in the Mission Bay Park Master Plan, prepared with significant public input, and complies with key aspects of City Charter Section 55.2. Public which were not involved in the Master Plan may oppose, or want more from these projects.	Low	Low	High	Mitigate	The risk associated with project controversy will be mitigated by involving the public in the development of the project and minimizing the negative project impacts.

RISK ASSESSMENT TABLE			Project Name: <b>Mission Beach Seawall Improvement Study</b>					
Risk Description			Risk Assessment			Risk Response		
ID #	Category	Title	Risk Statement	Probability	Cost Impact	Time Impact	Strategy	Response Actions
8	Sensitive Habitat	Existing sensitive habitat which may be impacted by construction	This study assumes the existing beach is recreational beach habitat and sensitive habitat will not be temporarily impacted during construction.	Low	Low	Low	Investigate	Confirmation of the on-site habitat should be made leading to final design. Should sensitive habitat be present, mitigation measures e.g. avoidance or other measures will be put in place. Therefore, further mitigation is unlikely to be necessary.
9	Sea Level Rise	The potential for projected rising water levels to affect the seawall function	Two sea level rise (SLR) projections (1.6 ft and 4.9 ft) were selected for Years 2050 and 2100 that represent major thresholds for the project. Designing the seawall for these sea level rise scenarios was deemed inappropriate at this point in time, as such a project would be too cost prohibitive under those SLR scenarios and the risk of community flooding will more likely come from the Mission Bay side of the boardwalk.	Moderate	High	Low	Adaptive	SLR is not anticipated to increase significantly until after 2050. Therefore, there is time to gather more data and monitor the rate at which SLR actually occurs in San Diego. Presently, climate models diverge on the rate of SLR after 2050. It is anticipated that the models will reach more of a consensus, however, as the timeline gets closer to Year 2050 and more SLR data is analyzed. Planning for a design change to the seawall will be dependent on new SLR data that is available and analyzed. Continue monitoring the SLR data in San Diego and adjust the planning timeline for seawall design changes in accordance with the data and policy guidelines.
10	Permitting	Potential constraining environmental regulation requirements and unanticipated changes	As a result of the need to receive approval from multiple resource permitting agencies, the possibility of project delays during approval could occur which would result in an increased project schedule or require new mitigations	Moderate	Low	High	Mitigate	Obtain the CEQA document and engage resource agencies early in the process to anticipate and negotiate constraining regulations. During the approval process, the team will work directly with the resource agencies to ensure timely response times and the efficient transfer of information. The project will be required to comply with the latest regulations.
11	Sand level	Potential loss of significant amount of beach elevation and volume due to a severe rare storm event e.g. El Nino	As a result of severe winter storm events e.g. strong El Niño's, the sand elevation along the boardwalk is subject to severe erosion and loss of beach elevation. This will also result in a great elevation difference between the boardwalk and public beach. The risk of beach erosion becomes higher if storm waves from these events coincide with peak tide conditions (high tides).	Moderate	Moderate	Moderate	Mitigate	Assess the public beach hazard and restrict beach access, if warranted. Signage could also be put in place to warn the public of the hazard.