



Project No. G2338-42-02

August 9, 2024

JPI

11988 El Camino Real, Suite 200

San Diego, CA 92130

Attention: Mr. Conner Kloeppe

Subject: UPDATE LETTER AND RESPONSE TO CITY OF SAN DIEGO REVIEW COMMENTS
THE COLLECTION AT CACTUS
NORTHEAST CORNER OF AIRWAY ROAD AND CACTUS COURT
SAN DIEGO, CALIFORNIA

- References:
1. *Collection at Cactus Entitlement Submittal*, e-mail message prepared by Conner Kloeppe, dated August 8, 2024, 7:01:11 PM.
 2. *Due Diligence Geotechnical Investigation, The Collection At Cactus, Northeast Corner of Airway Road And Cactus Court, San Diego, California*, prepared by Geocon Incorporated, dated May 18, 2023 (Project No. G2338-42-02).
 3. *Geotechnical Investigation, Otay Central Village, Planning Areas 10-13 And 7, Airway Road and Cactus Road, San Diego, California*, prepared by Geocon Incorporated, dated April 8, 2019 (Project No. G2338-42-01).
 4. *Geotechnical Investigation, Airway Road and Britannia Boulevard, San Diego, California*, prepared by Geocon Incorporated, dated April 16, 2021 (Project No. G2694-42-01).

Dear Mr. Kloeppe:

We prepared this letter to respond to the City of San Diego DSD-Geology review comments for the subject project that were conveyed to us via Reference 1. The review comment pertaining to geotechnical aspects and our response is presented below.

Comment 5: *Indicate if rocks or liquids containing deleterious chemicals are present which, if not corrected, could cause construction material such as concrete, steel, and ductile or cast iron to corrode or deteriorate.*

Response: It is our opinion that there are no naturally occurring rocks or liquids present at the locations tested (References 2, 3, and 4) that would cause “construction material such as concrete, steel, and ductile or cast iron to corrode or deteriorate”; however, we do

not practice in the field of corrosion engineering and further evaluation by a corrosion engineer will be needed if improvements susceptible to corrosion are planned.

Comment 6: *The project's geotechnical consultant should clarify if the property that is proposed of the tentative map is safe from geologic hazards.*

Response: Our evaluation of geologic hazards present at the site were presented in Reference 2 with the following results: there are no active faults, potentially active faults, inactive faults, or activity unknown faults at the site or trending toward the site, the risk associated with ground rupture hazard is low; the risk associated with strong seismic ground motion hazard is high, however, the risk is no greater than that for the site vicinity, the seismic design of structures should be done in accordance with the California Building Code currently adopted by the City of San Diego; the risk associated with flooding due to tsunami or seiche hazard is low; the risk associated with ground subsidence is low; and the risk associated with inundation hazard due to flooding is low.

Comment 7: *The project's geotechnical consultant should provide a conclusion regarding if the proposed development will destabilize or result in settlement of adjacent property the right of way.*

Response: It is our opinion that the currently proposed development will not "destabilize or result in settlement of adjacent property the right of way" provided that the proposed development is properly designed and constructed in accordance with the geotechnical recommendations presented in Reference 2 and 3.

If there are any questions regarding this correspondence, or if we may be of further service, please contact the undersigned at your convenience.

Very truly yours,

GEOCON INCORPORATED

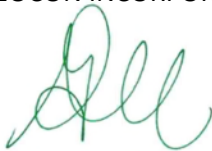

Garry W. Cannon
CEG 2201, RCE 56468

GWC:RSA:arm
(e-mail) Addressee



Rupert S. Adams
CEG 2561

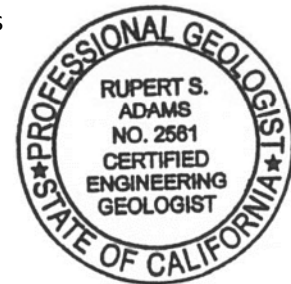

**DUE DILIGENCE GEOTECHNICAL
INVESTIGATION**

**THE COLLECTION AT CACTUS
NORTHEAST CORNER OF AIRWAY
ROAD AND CACTUS ROAD
SAN DIEGO, CALIFORNIA**



GEOCON
INCORPORATED

GEOTECHNICAL
ENVIRONMENTAL
MATERIALS

PREPARED FOR

JPI
SAN DIEGO, CALIFORNIA

MAY 18, 2023
PROJECT NO. G2338-42-02



Project No. G2338-42-02
May 18, 2023

JPI
11988 El Camino Real, Suite 200
San Diego, California 92130

Attention: Mr. Conner Kloeppel

Subject: DUE DILIGENCE GEOTECHNICAL INVESTIGATION
THE COLLECTION AT CACTUS
NORTHEAST CORNER OF AIRWAY ROAD AND CACTUS COURT
SAN DIEGO, CALIFORNIA

Dear Mr. Kloeppel:

In accordance with your request, we have performed a due diligence geotechnical investigation for the subject project. The accompanying report presents the findings of our study and our conclusions and recommendations pertaining to geotechnical aspects of developing the property as proposed.

It is our opinion that the site can be developed as currently proposed, provided the recommendations of this report are followed.

Should you have questions regarding this report, or if we may be of further service, please contact the undersigned at your convenience.

Very truly yours,

GEOCON INCORPORATED

Lilian E. Rodriguez
RCE 83227

LER:RCM:RSA:arm

(e-mail) Addressee



Rodney C. Mikesell
GE 2533



Rupert S. Adams
CEG 2561

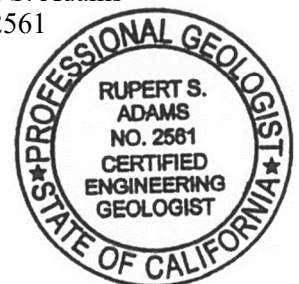

TABLE OF CONTENTS

1.	PURPOSE AND SCOPE	1
2.	SITE AND PROJECT DESCRIPTION	2
3.	SOIL AND GEOLOGIC CONDITIONS	2
3.1	Topsoil (Unmapped).....	3
3.2	Terrace Deposits-Clay Member (Qtc)	3
3.3	Terrace Deposits-Sand/Gravel Member (Qtg).....	3
3.4	Otay Formation (To).....	4
4.	GROUNDWATER	4
5.	GEOLOGIC HAZARDS	4
5.1	Geologic Hazard Category	4
5.2	Ground Rupture	4
5.3	Seismicity	5
5.4	Liquefaction Potential.....	5
5.5	Tsunamis and Seiches.....	5
5.6	Subsidence	5
5.7	Flooding.....	5
6.	CONCLUSIONS AND RECOMMENDATIONS.....	6
6.1	General.....	6
6.2	Excavation and Soil Characteristics	6
6.3	Temporary Excavations	7
6.4	Grading	8
6.5	Slopes.....	9
6.6	Seismic Design Criteria – 2022 California Building Code.....	10
6.7	Foundation and Concrete Slabs-On-Grade Recommendations	12
6.8	Retaining Walls	18
6.9	Lateral Loading.....	20
6.10	Storm Water Management.....	21
6.11	Site Drainage and Moisture Protection.....	23
6.12	Grading and Foundation Plan Review	23

LIMITATIONS AND UNIFORMITY OF CONDITIONS

MAPS AND ILLUSTRATIONS

Figure 1, Geologic Map

APPENDIX A

PREVIOUS FIELD INVESTIGATIONS

APPENDIX B

LABORATORY TESTING

APPENDIX C

RECOMMENDED GRADING SPECIFICATIONS

LIST OF REFERENCES

DUE DILIGENCE GEOTECHNICAL INVESTIGATION

1. PURPOSE AND SCOPE

This report contains the results of our due diligence geotechnical investigation for the proposed Collections at Cactus development located northeast of the Airway Road and Cactus Road intersection in San Diego, California (see Vicinity Map).



Vicinity Map

The purpose of this due diligence geotechnical investigation is to evaluate general site geology and soil conditions, identify geotechnical constraints that could impact development of the property, and provide geotechnical recommendations for remedial grading, shallow foundations, and retaining walls.

To aid in the preparation of this report, we reviewed the following plans and geotechnical report:

1. *Conceptual Site Plan*, prepared by Summa Architects, undated.
2. *Geotechnical Investigation, Otay Central Village, Planning Areas 10-13 and 17, Airway Road and Cactus Road, San Diego, California*, prepared by Geocon Incorporated, dated April 9, 2019 (Project No. G2338-42-01).

The scope of this investigation included: a review of readily available published and unpublished geologic literature, a review of the referenced geotechnical report, engineering analysis, and preparation of this report. We previously excavated 3 exploratory borings and 16 exploratory trenches to a maximum depth of 16 feet below ground surface, performed infiltration testing, and performed laboratory testing of soil samples. The locations of the previous exploratory borings, trenches, and infiltration tests are shown on the Geologic Map, Figure 1. We used a CAD file of the conceptual site plan to generate Figure 1. Logs of the exploratory trenches, borings, infiltration test-borings, and a detailed discussion of the field investigations are presented in Appendix A. Appendix B presents details of the laboratory tests and a summary of the test results, and Appendix C presents recommended grading specifications.

The conclusions and recommendations presented herein are based on our analysis of the data obtained from the exploratory field investigations, laboratory test results, and our experience with similar soil and geologic conditions on this and adjacent properties.

2. SITE AND PROJECT DESCRIPTION

The project site is approximately 40 acres in size, bounded by the 905 freeway on the north, Airway Road on the south, Cactus Road on the west, and a partially graded vacant lot to the east. An automobile/truck service yard and several single-story residential homes are located west of the site along Cactus Road.

The property is characterized by gently sloping topography (Figure 1), draining from the southeast to the northwest to a drainage channel running parallel to the east-bound lanes of the 905 freeway. Existing site elevations range from approximately 494 to 515 feet Mean Sea Level (MSL). Based on a review of historical aerial photographs, previous land uses include cultivation of small orchards and arable farming.

Based on the conceptual site plan (Reference 1), the proposed development consists of constructing multi-story residential buildings including townhomes, stacked flats, and apartments. The project will also have a 3.5-acre park, parking lots, and a biofiltration basins for storm water management. Based on preliminary grading information, planned grading will result in cuts and fills of approximately 5 feet or less from existing grades to construct planned sheet grade elevations across the site.

3. SOIL AND GEOLOGIC CONDITIONS

We encountered topsoil underlain by Pleistocene terrace deposits during our field investigation. Descriptions of these geologic units are described herein and shown on the exploratory trench and boring logs in Appendix A.

3.1 Topsoil (Unmapped)

Topsoil blankets the entire site and is generally composed of very soft to stiff, sandy clay and loose, silty to clayey sand. The topsoil thickness ranges from approximately one to four feet. Topsoil is compressible in its present condition and will require removal and decompaction.

3.2 Terrace Deposits-Clay Member (Qtc)

The Pleistocene-age upper Terrace Deposit clay member (Qtc) consists of a highly expansive clay, encountered in all exploratory trenches except TP-1 and TP-2, located in the northwest corner of the site (Figure 1). The clay member is approximately two to greater than 14 feet thick, consisting of firm to hard, damp to moist, grayish brown to olive brown, clay, silty clay, and sandy clay. The base of the clay member was not found along the south side of the site in trenches TP-12 through TP-14.

Expansion testing performed on this site and other adjacent sites indicates the upper Terrace Deposit clay member has highly expansive characteristics. The clay will require remedial grading in the form of removal and replacement with *low* expansive soils within the upper 5 feet of planned finish grade. Trenches excavated on adjacent properties found that the clay is occasionally interbedded with dense, cemented silty to clayey sandstone. Where cemented zones are encountered, excavations may generate oversize material requiring special handling and placement.

3.3 Terrace Deposits-Sand/Gravel Member (Qtg)

The Pleistocene-age lower terrace member (Qtg) underlies the upper clay member, and consists of medium dense to very dense, damp to moist, reddish- to yellowish-brown, medium dense to dense, Clayey and Silty Sand with varying amounts of cobble. This unit is massive to weakly stratified, with occasional discontinuous cobble and gravel lenses. The surrounded gravel and cobble clasts range from 3- to 18-inches in diameter, and are derived from volcanic, metasedimentary and granitic rocks. Cobble clast size generally increases with depth and may exceed 18-inches in deeper excavations.

Excavation of the Qtg member will require moderate to heavy effort with conventional heavy-duty earth-moving equipment. Larger than normal excavators may be required to excavate deeper utility trenches.

Typically, in the Otay area, the upper clay deposit (Qtc) is removed, and the underlying sandy/gravel unit (Qtg) is mined to provide select capping material. The clay soils are then replaced and compacted in the mined excavation at depths of at least five feet below planned finish grade. Deeper burial depths may be required if subterranean building levels are planned.

3.4 Otay Formation (To)

The Otay Formation underlies the terrace deposits and is generally composed of dense to hard, light olive to gray-brown, horizontally interbedded clayey siltstones and silty fine-grained sandstone. The Otay Formation was not encountered to the maximum explored depth of 16-feet below site grades; however, it may be encountered during site grading. The Otay Formation typically possess low to moderate expansion, good shear strength characteristics, and is generally suitable for support of structural loads and/or fills in its present condition.

4. GROUNDWATER

We did not encounter groundwater in the trenches or borings during our field investigations. Based on the proposed improvements, we do not expect groundwater to have an adverse impact on the project; however, it is not uncommon for groundwater or seepage conditions to develop where none previously existed. Groundwater elevations are dependent on seasonal precipitation, irrigation, land use, among other factors, and vary as a result. Proper surface drainage will be important to the future performance of the project.

5. GEOLOGIC HAZARDS

5.1 Geologic Hazard Category

Based on our review of geologic literature and experience with the soil and geologic conditions in the general area, it is our opinion that known active, potentially active, or inactive faults are not located at the site. The site is not within a State of California Earthquake Fault Zone.

The site is described in City of San Diego (2008) as having Geologic Hazard Category 53; *Level or sloping terrane, unfavorable geologic structure, Low to moderate risk.*

5.2 Ground Rupture

The USGS (2019) and Kennedy & Tan (2008) show that there are no mapped Quaternary faults crossing or trending toward the property. The site is not located within a currently established Alquist-Priolo Earthquake Fault Zone (CEG, 2021a).

There are no active faults, potentially active faults, inactive faults, or activity unknown faults at the site or trending toward the site. The nearest active fault is the Rose Canyon Fault, which lies approximately 9 miles west of the site. The risk associated with ground rupture hazard is low.

5.3 Seismicity

Considerations important in seismic design include frequency and duration of motion and soil conditions underlying the site. Seismic design of structures should be evaluated in accordance with the California Building Code currently adopted by the City of San Diego. The risk associated with strong seismic ground motion hazard is high; however, the risk is no greater than that for the site vicinity.

5.4 Liquefaction Potential

The potential for liquefaction occurring within the site soils is considered to be very low due to the lack of a near surface groundwater table, and the density of the terrace deposits.

5.5 Tsunamis and Seiches

The site is not mapped within a State of California tsunami hazard zone (CGS, 2021b). The site is not located near a large body of water. The risk associated with flooding due to tsunami or seiche hazard is low.

5.6 Subsidence

Based on the subsurface soil conditions observed, the risk associated with ground subsidence is low.

5.7 Flooding

The site is not mapped in a Special Flood Hazard Area as defined by FEMA (2020). The risk of inundation hazard due to flooding is low.

6. CONCLUSIONS AND RECOMMENDATIONS

6.1 General

- 6.1.1 From a geotechnical engineering standpoint, it is our opinion that the site is suitable for the proposed development provided the recommendations presented herein are implemented in design and construction of the project.
- 6.1.2 The site is underlain by Pleistocene-age terrace deposits mantled by topsoil. Laboratory tests indicate the topsoil and the upper terrace deposit member (Qtc) exhibit *very high* expansion characteristics (EI greater than 130). Remedial will be required for the onsite topsoil and clayey portions of the old terrace deposits. The lower sandy portions of the terrace deposits (Qtg) are suitable for the support of the proposed loads or additional engineered fill.
- 6.1.3 We did not encounter groundwater during the field investigation. We expect excavations for the proposed improvements will be relatively shallow; therefore, we do not expect groundwater to have an adverse impact on the project as currently proposed.
- 6.1.4 The site is located approximately nine miles east of the Newport-Inglewood/Rose Canyon fault zone. Based on our review of available literature, active, potentially active, or presumed inactive faults do not cross the site.
- 6.1.5 With the exception of possible strong seismic shaking, we did not observe or know of significant geologic hazards that would adversely affect the proposed development.
- 6.1.6 The risks associated with soil liquefaction and flooding hazards are low.
- 6.1.7 The proposed structures can be supported on a shallow foundation system founded entirely on properly compacted fill soil.
- 6.1.8 Subsurface conditions observed may be extrapolated to reflect general soil/geologic conditions; however, some variations in subsurface conditions between trench and boring locations should be anticipated.

6.2 Excavation and Soil Characteristics

- 6.2.1 Excavation of the onsite soils should be possible with moderate to heavy effort using conventional, heavy-duty equipment during grading and trenching operations.

6.2.2 The soil encountered in our field investigation is considered to be both “expansive” (Expansion Index [EI] greater than 20) and “non-expansive” (EI of 20 and less) as defined by 2022 California Building Code (CBC) Section 1803.5.3. Table 6.2 presents soil classifications based on the expansion index.

**TABLE 6.2
EXPANSION CLASSIFICATION BASED ON EXPANSION INDEX**

Expansion Index (EI)	ASTM D 4829 Expansion Classification	2022 CBC Expansion Classification
0 – 20	Very Low	Non-Expansive
21 – 50	Low	Expansive
51 – 90	Medium	
91 – 130	High	
Greater Than 130	Very High	

6.2.3 We performed laboratory tests on samples of the site materials to evaluate the percentage of water-soluble sulfate content. Appendix B presents the results from the laboratory water-soluble sulfate content tests. The test results indicate that on-site materials at the locations tested possess “S0” sulfate exposure to concrete structures, as defined by 2016 CBC Section 1904 and ACI 318-14 Chapter 19. The presence of water-soluble sulfates is not a visually discernible characteristic. Therefore, other soil samples from the site could yield different concentrations. Additionally, over time landscaping activities (i.e. addition of fertilizers and other soil nutrients) may affect the concentration.

6.2.4 Geocon Incorporated does not practice in the field of corrosion engineering. Therefore, if improvements that could be susceptible to corrosion are planned, further evaluation by a corrosion engineer may be needed.

6.3 Temporary Excavations

6.3.1 Temporary excavations should be constructed in conformance with OSHA requirements. The on-site Terrace Deposits and proposed compacted fill should be considered Type B soil in accordance with OSHA requirements. In general, special shoring requirements will not be necessary if temporary excavations are less than 4 feet high. Temporary excavation depths greater than 4 feet should be laid back at an appropriate inclination or shored. The soils exposed in these excavations should not become saturated or allowed to dry. Surcharge loads should not be permitted within a distance equal to the depth of the excavation from the top of the excavation. The top of the excavation should be a minimum of 15 feet from the edge of existing improvements. Excavations steeper than those recommended or closer than 15 feet

from an existing surface improvement should be shored in accordance with applicable OSHA codes and regulations.

6.4 Grading

- 6.4.1 All grading should be performed in accordance with the *Recommended Grading Specifications* contained in Appendix C. Where the recommendations of Appendix C conflict with this section of the report, the recommendations of this section take precedence.
- 6.4.2 Prior to commencing grading, a preconstruction conference should be held at the site with the owner or developer, grading contractor, civil engineer, and geotechnical engineer in attendance. Special soil handling and/or the grading plans can be discussed at that time.
- 6.4.3 Grading should be performed in conjunction with the observation and compaction testing services of Geocon Incorporated. Fill soil should be observed on a full-time basis during placement and tested to check in-place dry density and moisture content.
- 6.4.4 Site preparation should begin with removal of all deleterious material and vegetation. The depth of removal should be such that material exposed in cut areas or soil to be used for fill is relatively free of organic matter. Deleterious material generated during stripping and/or site demolition should be exported from the site.
- 6.4.5 Abandoned utilities should be removed and the subsequent depressions and/or trenches backfilled with properly compacted fill as part of the remedial grading.
- 6.4.6 Compressible surficial soils (topsoil and weathered portion of Terrace Deposits) should be removed to firm natural ground and properly recompacted prior to placing structural fill and/or loading.
- 6.4.7 After removal of compressible soils, the upper portion of the Terrace Deposits – Clay Member should be removed to a depth of at least 5 feet below finish pad grade or 3 feet below the bottom of building footings, whichever results in a deeper excavation. The resulting excavation should be replaced with “low” to “medium” expansive soils (EI less than 90). The expansive clays should be placed and compacted to a depth no closer than 5 feet below finish subgrade elevation and 3 feet below building footings. Typically, this requires removal of the upper Terrace Deposit Clay, mining of the underlying sand and gravel, placing the clay at the base of the mined excavation and then utilizing the mined sand and gravel soils to construct the 5-foot cap of low expansive soil. Geocon Incorporated should be contacted if alternate recommendations, such as lime treatment of the expansive clay soils, is desired.

- 6.4.8 If grading results in a cut to fill transition within the sand and gravel Terrace Deposits, the cut portion of the pad should be undercut to a depth of at least 3 feet below pad grade, or 1 foot below the bottom of building footings, whichever results in a deeper excavation, are the undercut area replaced with “low” to “medium” expansive soils. All building pad undercuts should extend to at least 5 feet horizontally beyond the building pad limits.
- 6.4.9 Prior to placing fill, the upper 12 inches at the base of removals and areas to receive fill should be scarified, moisture conditioned as necessary and recompacted. Soils derived from onsite excavations are suitable for reuse as fill if free from vegetation, debris and other deleterious material. Fill lifts should be no thicker than will allow for adequate bonding and compaction. Fill, backfill, and scarified ground surfaces, should be compacted to a dry density of at least 90 percent of maximum dry density at or slightly above optimum moisture content, as determined in accordance with ASTM D 1557.
- 6.4.10. Oversize rock greater than 12 inches should be placed at least 5 feet below finish pad grade or 3 feet below the deepest utility, whichever is greater. Rock greater than 6 inches should not be placed in the upper 3 feet below building pad grade. Oversize rock that cannot be placed as recommended should be exported off site.
- 6.4.11 Imported fill should consist of granular soil with a *low* to *medium* expansion potential (EI of 50 or less), be free of deleterious material or stones larger than 3 inches, and compacted as recommended above. Geocon Incorporated should be notified of the import soil source and should perform laboratory testing prior to its arrival at the site to evaluate its suitability as fill material.

6.5 Slopes

- 6.5.1 Fill slopes are proposed along the west side of Cactus Road to the northwest of the site. Fill slopes will have maximum heights on the order of 10 to 15 feet and inclined at 2:1 (horizontal to vertical) or flatter.
- 6.5.2 The outer 15 feet (or a distance equal to the height of the slope, whichever is less) of fill slopes should consist of properly compacted granular soil fill to reduce the potential for surface sloughing. All fill slopes should be track walked upon completion such that the fill soils are uniformly compacted to at least 90 percent relative compaction to the face of the finish slope.
- 6.5.3 All slopes should be planted, drained, and maintained to reduce erosion.

6.6 Seismic Design Criteria – 2022 California Building Code

6.6.1 Table 6.6.1 summarizes site-specific design criteria obtained from the 2022 California Building Code (CBC; Based on the 2021 International Building Code [IBC] and ASCE 7-16), Chapter 16 Structural Design, Section 1613 Earthquake Loads. We used SEAOC (2019) to calculate the seismic design parameters. The short spectral response uses a period of 0.2 second. We evaluated the Site Class based on the discussion in Section 1613.2.2 of the 2022 CBC and Table 20.3-1 of ASCE 7-16. The values presented herein are for the risk-targeted maximum considered earthquake (MCE_R). Sites designated as Site Class D, E and F may require additional analyses if requested by the project structural engineer and client.

**TABLE 6.6.1
2022 CBC SEISMIC DESIGN PARAMETERS**

Parameter	Value	2022 CBC Reference
Site Class	D	Section 1613.2.2
MCE_R Ground Motion Spectral Response Acceleration – Class B (short), S_S	0.752g	Figure 1613.2.1(1)
MCE_R Ground Motion Spectral Response Acceleration – Class B (1 sec), S_1	0.276g	Figure 1613.2.1(3)
Site Coefficient, F_A	1.199	Table 1613.2.3(1)
Site Coefficient, F_V	2.048	Table 1613.2.3(2)
Site Class Modified MCE_R Spectral Response Acceleration (short), S_{MS}	0.902g	Section 1613.2.3 (Eqn 16-20)
Site Class Modified MCE_R Spectral Response Acceleration – (1 sec), S_{M1}	0.565g	Section 1613.2.3 (Eqn 16-21)
5% Damped Design Spectral Response Acceleration (short), S_{DS}	0.601g	Section 1613.2.4 (Eqn 16-22)
5% Damped Design Spectral Response Acceleration (1 sec), S_{D1}	0.377g	Section 1613.2.4 (Eqn 16-23)

6.6.2 Using the code-based values presented in this Table 6.6.1, in lieu of a performing a ground motion hazard analysis, requires the exceptions outlined in ASCE 7-16 Section 11.4.8 be followed by the project structural engineer. Per Section 11.4.8 of ASCE/SEI 7-16, a ground motion hazard analysis should be performed for projects for Site Class “E” sites with S_S greater than or equal to 1.0g and for Site Class “D” and “E” sites with S_1 greater than 0.2g. Section 11.4.8 also provides exceptions which indicates that the ground motion hazard analysis may be waived provided the exceptions are followed.

6.6.3 Table 6.6.2 presents the mapped maximum considered geometric mean (MCE_G) seismic design parameters for projects located in Seismic Design Categories of D through F in accordance with ASCE 7-16.

**TABLE 6.6.2
ASCE 7-16 PEAK GROUND ACCELERATION**

Parameter	Value	ASCE 7-16 Reference
Mapped MCE_G Peak Ground Acceleration, PGA	0.328g	Figure 22-9
Site Coefficient, F_{PGA}	1.272	Table 11.8-1
Site Class Modified MCE_G Peak Ground Acceleration, PGA_M	0.417g	Section 11.8.3 (Eqn 11.8-1)

6.6.4 Conformance to the criteria in Tables 6.6.1 and 6.6.2 for seismic design does not constitute any kind of guarantee or assurance that significant structural damage or ground failure will not occur in the event of a large earthquake. The primary goal of seismic design is to protect life, not to avoid all damage, since such design may be economically prohibitive.

6.6.5 The project structural engineer and architect should evaluate the appropriate Risk Category and Seismic Design Category for the planned structures. The values presented herein assume a Risk Category II and a Seismic Design Category D. Table 6.6.3 presents a summary of the risk categories in accordance with ASCE 7-16.

**TABLE 6.6.3
ASCE 7-16 RISK CATEGORIES**

Risk Category	Building Use	Examples
I	Low risk to Human Life at Failure	Barn, Storage Shelter
II	Nominal Risk to Human Life at Failure (Buildings Not Designated as I, III or IV)	Residential, Commercial and Industrial Buildings
III	Substantial Risk to Human Life at Failure	Theaters, Lecture Halls, Dining Halls, Schools, Prisons, Small Healthcare Facilities, Infrastructure Plants, Storage for Explosives/Toxins
IV	Essential Facilities	Hazardous Material Facilities, Hospitals, Fire and Rescue, Emergency Shelters, Police Stations, Power Stations, Aviation Control Facilities, National Defense, Water Storage

6.7 Foundation and Concrete Slabs-On-Grade Recommendations

6.7.1 The foundation recommendations herein are for proposed one- to three-story residential structures. The foundation recommendations have been separated into three categories based on either the maximum and differential fill thickness or Expansion Index. The foundation category criteria are presented in Table 6.7.1. Final foundation categories for individual lots will be presented in our as-graded report once fill thickness, differential fill thickness, and expansion index of finish grade soils are known.

**TABLE 6.7.1
FOUNDATION CATEGORY CRITERIA**

Foundation Category	Maximum Fill Thickness, T (feet)	Differential Fill Thickness, D (feet)	Expansion Index (EI)
I	$T < 20$	--	$EI \leq 50$
II	$20 \leq T < 50$	$10 \leq D < 20$	$50 < EI \leq 90$
III	$T \geq 50$	$D \geq 20$	$90 < EI \leq 130$

6.7.2 Table 6.7.2 presents minimum foundation and interior concrete slab design criteria for conventional foundation systems.

**TABLE 6.7.2
CONVENTIONAL FOUNDATION RECOMMENDATIONS BY CATEGORY**

Foundation Category	Minimum Footing Embedment Depth, D (inches)	Minimum Continuous Footing Reinforcement	Minimum Footing Width (Inches)
I	12	Two No. 4 bars, one top and one bottom	12 – Continuous, W_C 24 – Isolated, W_I
II	18	Four No. 4 bars, two top and two bottom	
III	24	Four No. 5 bars, two top and two bottom	

6.7.3 The foundations should be embedded in accordance with the recommendations herein and the Wall/Column Footing Dimension Detail. The embedment depths should be measured from the lowest adjacent pad grade for both interior and exterior footings. Footings should be deepened such that the bottom outside edge of the footing is at least 7 feet horizontally from the face of the slope (unless designed with a post-tensioned foundation system as discussed herein).

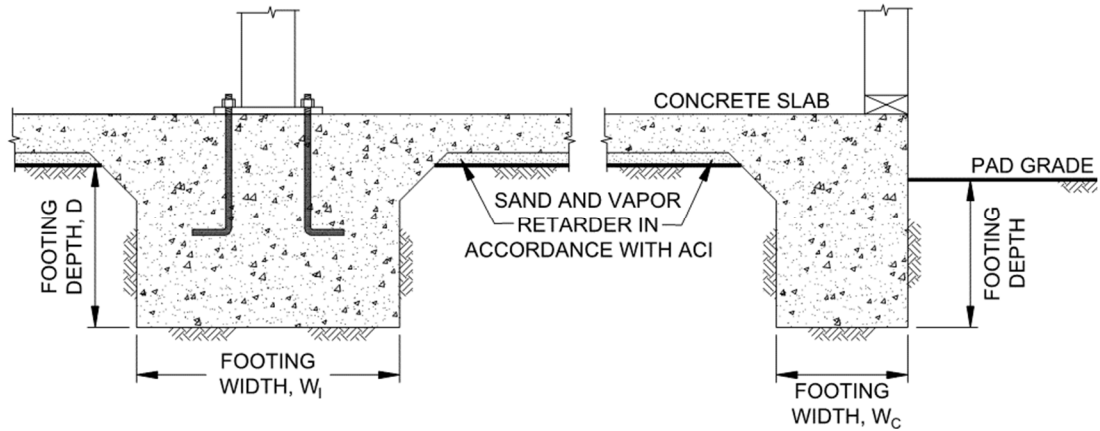

Wall/Column Footing Dimension Detail

6.7.4 The proposed structures can be supported on a shallow foundation system founded in compacted fill. Table 6.7.3 provides a summary of the foundation design recommendations.

**TABLE 6.7.3
SUMMARY OF FOUNDATION RECOMMENDATIONS**

Parameter	Value
Allowable Bearing Capacity	2,000 psf
Bearing Capacity Increase	500 psf per Foot of Depth
	300 psf per Foot of Width
Maximum Allowable Bearing Capacity	3,500 psf
Estimated Total Settlement	1 Inch
Estimated Differential Settlement	½ Inch in 40 Feet

6.7.5 The bearing capacity values presented herein are for dead plus live loads and may be increased by one-third when considering transient loads due to wind or seismic forces.

6.7.6 The concrete slab-on-grades should be designed in accordance with Table 6.7.4.

**TABLE 6.7.4
CONVENTIONAL SLAB-ON-GRADE RECOMMENDATIONS BY CATEGORY**

Foundation Category	Minimum Concrete Slab Thickness (inches)	Interior Slab Reinforcement	Typical Slab Underlayment
I	4	6 x 6 - 10/10 welded wire mesh at slab mid-point	3 to 4 Inches of Sand/Gravel/Base
II	4	No. 3 bars at 24 inches on center, both directions	
III	5	No. 3 bars at 18 inches on center, both directions	

- 6.7.7 Slabs that may receive moisture-sensitive floor coverings or may be used to store moisture-sensitive materials should be underlain by a vapor retarder. The vapor retarder design should be consistent with the guidelines presented in the American Concrete Institute’s (ACI) *Guide for Concrete Slabs that Receive Moisture-Sensitive Flooring Materials* (ACI 302.2R-06). The vapor retarder used should be specified by the project architect or developer based on the type of floor covering that will be installed and if the structure will possess a humidity controlled environment.
- 6.7.8 The bedding sand thickness should be determined by the project foundation engineer, architect, and/or developer. However, we should be contacted to provide recommendations if the bedding sand is thicker than 6 inches. It is common to see 3 inches and 4 inches of sand below the concrete slab-on-grade for 5-inch and 4-inch thick slabs, respectively, in the southern California area.
- 6.7.9 The foundation design engineer should provide appropriate concrete mix design criteria and curing measures to assure proper curing of the slab by reducing the potential for rapid moisture loss and subsequent cracking and/or slab curl. We suggest that the foundation design engineer present the concrete mix design and proper curing methods on the foundation plans. It is critical that the foundation contractor understands and follows the recommendations presented on the foundation plans.
- 6.7.10 As an alternative to the conventional foundation recommendations, consideration should be given to the use of post-tensioned concrete slab and foundation systems for the support of the proposed structures. The post-tensioned systems (foundation dimensions and embedment depths, slab thickness and steel placement) should be designed by a structural engineer experienced in post-tensioned slab design and design criteria of the Post-Tensioning Institute (PTI) DC 10.5-12 *Standard Requirements for Design and Analysis of Shallow Post-Tensioned*

Concrete Foundations on Expansive Soils or *WRI/CRSI Design of Slab-on-Ground Foundations*, as required by the 2022 California Building Code Section 1808.6.2. Although this procedure was developed for expansive soil conditions, it can also be used to reduce the potential for foundation distress due to differential fill settlement. The post-tensioned design should incorporate the geotechnical parameters presented in Table 6.7.5 for the particular Foundation Category designated. The parameters presented in Table 6.7.5 are based on the guidelines presented in the PTI DC 10.5 design manual.

**TABLE 6.7.5
POST-TENSIONED FOUNDATION SYSTEM DESIGN PARAMETERS**

Post-Tensioning Institute (PTI) DC 10.5 Design Parameters	Foundation Category		
	I	II	III
Thornthwaite Index	-20	-20	-20
Equilibrium Suction	3.9	3.9	3.9
Edge Lift Moisture Variation Distance, e_M (feet)	5.3	5.1	4.9
Edge Lift, y_M (inches)	0.61	1.10	1.58
Center Lift Moisture Variation Distance, e_M (feet)	9.0	9.0	9.0
Center Lift, y_M (inches)	0.30	0.47	0.66

- 6.7.11 The foundations for the post-tensioned slabs should be embedded in accordance with the recommendations of the structural engineer. If a post-tensioned mat foundation system is planned, the slab should possess a thickened edge with a minimum width of 12 inches and extend below the clean sand or crushed rock layer.
- 6.7.12 If the structural engineer proposes a post-tensioned foundation design method other than PTI DC 10.5:
- The deflection criteria presented in Table 6.7.5 are still applicable.
 - Interior stiffener beams should be used for Foundation Categories II and III.
 - The width of the perimeter foundations should be at least 12 inches.
 - The perimeter footing embedment depths should be at least 12 inches, 18 inches and 24 inches for foundation categories I, II, and III, respectively. The embedment depths should be measured from the lowest adjacent pad grade.
- 6.7.13 Our experience indicates post-tensioned slabs may be susceptible to excessive edge lift, regardless of the underlying soil conditions. Placing reinforcing steel at the bottom of the perimeter footings and the interior stiffener beams may mitigate this potential. The structural

engineer should design the foundation system to reduce the potential of edge lift occurring for the proposed structures.

- 6.7.14 During the construction of the post-tension foundation system, the concrete should be placed monolithically. Under no circumstances should cold joints form between the footings/grade beams and the slab during the construction of the post-tension foundation system unless designed by the structural engineer.
- 6.7.15 Category I, II, or III foundations may be designed for an allowable soil bearing pressure of 2,000 pounds per square foot (psf) (dead plus live load). This bearing pressure may be increased by one-third for transient loads due to wind or seismic forces. The estimated maximum total and differential settlement for the planned structures due to foundation loads is 1 inch and ½ inch, respectively.
- 6.7.16 Isolated footings outside of the slab area, if present, should have the minimum embedment depth and width recommended for conventional foundations for a particular Foundation Category. The use of isolated footings, which are located beyond the perimeter of the building and support structural elements connected to the building, are not recommended for Category III. Where this condition cannot be avoided, the isolated footings should be connected to the building foundation system with grade beams. In addition, consideration should be given to connecting patio slabs, which exceed 5 feet in width, to the building foundation to reduce the potential for future separation to occur.
- 6.7.17 Interior stiffening beams should be incorporated into the design of the foundation system in accordance with the PTI design procedures.
- 6.7.18 Special subgrade presaturation is not deemed necessary prior to placing concrete; however, the exposed foundation and slab subgrade soil should be moisture conditioned, as necessary, to maintain a moist condition as would be expected in any such concrete placement.
- 6.7.19 Where buildings or other improvements are planned near the top of a slope 3:1 (horizontal:vertical) or steeper, special foundation and/or design considerations are recommended due to the tendency for lateral soil movement to occur.
- For fill slopes less than 20 feet high or cut slopes regardless of height, footings should be deepened such that the bottom outside edge of the footing is at least 7 feet horizontally from the face of the slope.
 - When located next to a descending 3:1 (horizontal:vertical) fill slope or steeper, the foundations should be extended to a depth where the minimum horizontal distance is

equal to $H/3$ (where H equals the vertical distance from the top of the fill slope to the base of the fill soil) with a minimum of 7 feet but need not exceed 40 feet. The horizontal distance is measured from the outer, deepest edge of the footing to the face of the slope. A post-tensioned slab and foundation system or mat foundation system can be used to reduce the potential for distress in the structures associated with strain softening and lateral fill extension. Specific design parameters or recommendations for either of these alternatives can be provided once the building location and fill slope geometry have been determined.

- If swimming pools are planned, Geocon Incorporated should be contacted for a review of specific site conditions.
- Swimming pools located within 7 feet of the top of cut or fill slopes are not recommended. Where such a condition cannot be avoided, the portion of the swimming pool wall within 7 feet of the slope face be designed assuming that the adjacent soil provides no lateral support. This recommendation applies to fill slopes up to 30 feet in height, and cut slopes regardless of height. For swimming pools located near the top of fill slopes greater than 30 feet in height, additional recommendations may be required and Geocon Incorporated should be contacted for a review of specific site conditions.
- Although other improvements, which are relatively rigid or brittle, such as concrete flatwork or masonry walls, may experience some distress if located near the top of a slope, it is generally not economical to mitigate this potential. It may be possible, however, to incorporate design measures which would permit some lateral soil movement without causing extensive distress. Geocon Incorporated should be consulted for specific recommendations.

6.7.20 The recommendations of this report are intended to reduce the potential for cracking of slabs and foundations due to expansive soil (if present), differential settlement of fill soil with varying thicknesses. However, even with the incorporation of the recommendations presented herein, foundations, stucco walls, and slabs-on-grade placed on such conditions may still exhibit some cracking due to soil movement and/or shrinkage. The occurrence of concrete shrinkage cracks is independent of the supporting soil characteristics. Their occurrence may be reduced by limiting the slump of the concrete, proper concrete placement and curing, and by the placement of crack control joints at periodic intervals, in particular, where re-entrant slab corners occur.

6.7.21 Concrete slabs should be provided with adequate crack-control joints, construction joints and/or expansion joints to reduce unsightly shrinkage cracking. The design of joints should consider criteria of the American Concrete Institute (ACI) when establishing crack-control spacing. Additional steel reinforcing, concrete admixtures and/or closer crack control joint spacing should be considered where concrete-exposed finished floors are planned.

6.7.22 Geocon Incorporated should be consulted to provide additional design parameters as required by the structural engineer.

6.8 Retaining Walls

6.8.1 Retaining walls, if planned, should be designed using the values presented in Table 6.8.1. Soil with an expansion index (EI) of greater than 90 should not be used as backfill soil behind retaining walls.

**TABLE 6.8.1
RETAINING WALL DESIGN RECOMMENDATIONS**

Parameter	Value
Active Soil Pressure, A (Fluid Density, Level Backfill)	40 pcf
Active Soil Pressure, A (Fluid Density, 2:1 Sloping Backfill)	55 pcf
Seismic Pressure, S	15H psf
At-Rest/Restrained Walls Additional Uniform Pressure, R_U (0 to 8 Feet High)	7H psf
At-Rest/Restrained Walls Additional Uniform Pressure, R_L (8+ Feet High)	13H psf
Expected Expansion Index for the Subject Property	$EI \leq 90$

H equals the height of the retaining portion of the wall

6.8.2 The project retaining walls should be designed as shown in the Retaining Wall Loading Diagram.

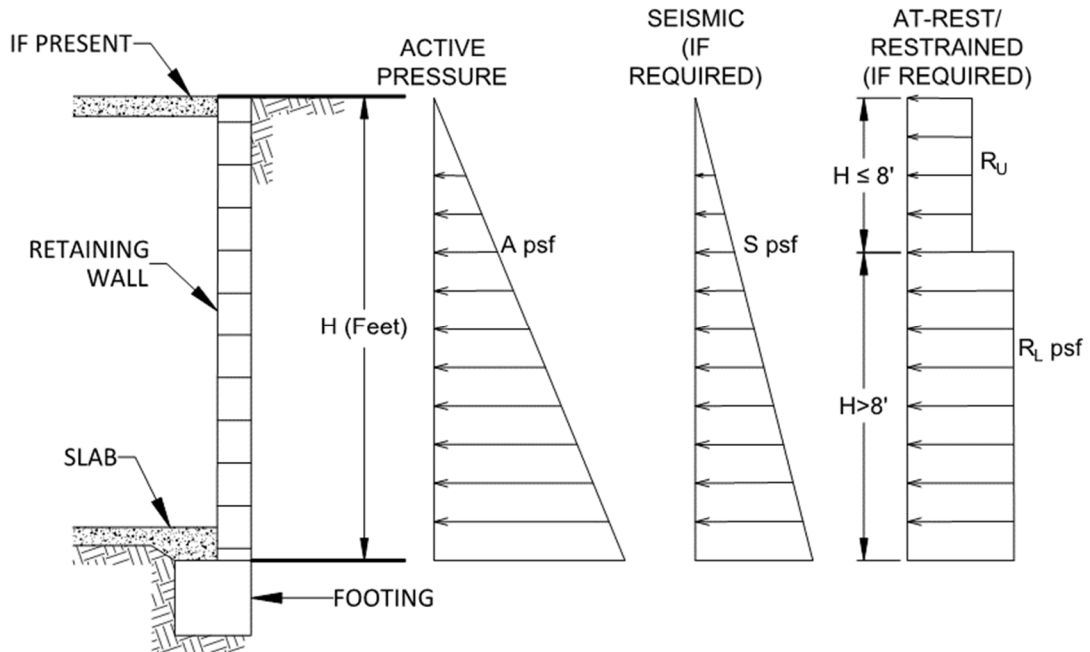

Retaining Wall Loading Diagram

6.8.3 Unrestrained walls are those that are allowed to rotate more than $0.001H$ (where H equals the height of the retaining portion of the wall) at the top of the wall.

- 6.8.4 Where walls are restrained from movement at the top (at-rest condition), an additional uniform pressure should be applied to the wall. For retaining walls subject to vehicular loads within a horizontal distance equal to two-thirds the wall height, a surcharge equivalent to 2 feet of fill soil should be added to the upper 10 feet of the retaining wall.
- 6.8.5 The structural engineer should determine the Seismic Design Category for the project in accordance with Section 1613 of the 2022 CBC or Section 11.6 of ASCE 7-16. For structures assigned to Seismic Design Category of D, E, or F, retaining walls that support more than 6 feet of backfill should be designed with seismic lateral pressure in accordance with Section 1803.5.12 of the 2022 CBC. The seismic load is dependent on the retained height where H is the height of the wall, in feet, and the calculated loads result in pounds per square foot (psf) exerted at the base of the wall and zero at the top of the wall.
- 6.8.6 It is not necessary to consider active pressure acting on foundation keyways.
- 6.8.7 Drainage openings through the base of the wall (weep holes) should not be used where the seepage could be a nuisance or otherwise adversely affect the property adjacent to the base of the wall. The recommendations herein assume a properly compacted granular (EI of 50 or less) free-draining backfill material with no hydrostatic forces or imposed surcharge load. The retaining wall should be properly drained as shown in the Typical Retaining Wall Drainage Detail. If conditions different than those described are expected, or if specific drainage details are desired, Geocon Incorporated should be contacted for additional recommendations.

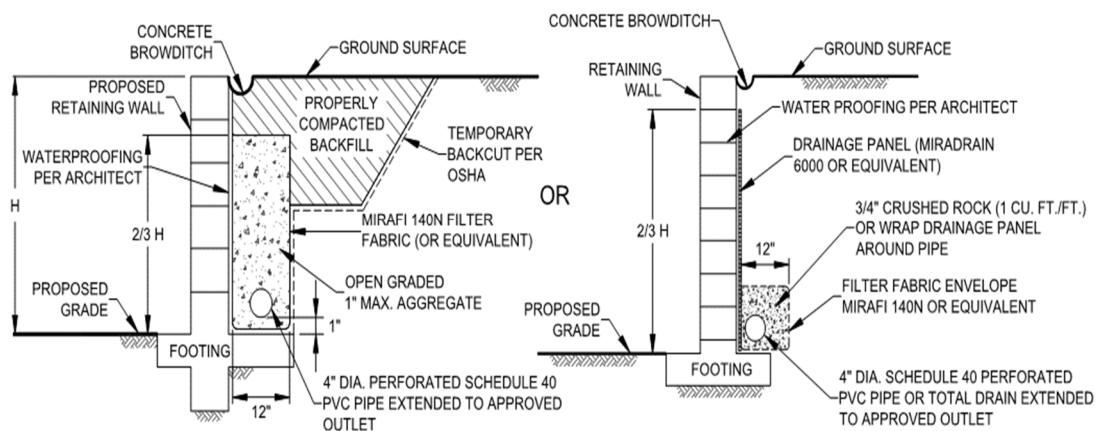

Typical Retaining Wall Drainage Detail

- 6.8.8 In general, wall foundations should be designed in accordance with Table 6.8.2. The proximity of the foundation to the top of a slope steeper than 3:1 could impact the allowable soil bearing pressure. Therefore, retaining wall foundations should be deepened such that the bottom outside edge of the footing is at least 7 feet horizontally from the face of the slope.

**TABLE 6.8.2
SUMMARY OF RETAINING WALL FOUNDATION RECOMMENDATIONS**

Parameter	Value
Minimum Retaining Wall Foundation Width	12 inches
Minimum Retaining Wall Foundation Depth	12 Inches
Minimum Concrete Reinforcement	Per Structural Engineer
Allowable Bearing Capacity	2,000 psf
Estimated Total Settlement	1 Inch
Estimated Differential Settlement	½ Inch in 40 Feet

- 6.8.9 The recommendations presented herein are generally applicable to the design of rigid concrete or masonry retaining walls. Geocon Incorporated should be consulted for additional recommendations for other types of walls (such as mechanically stabilized earth [MSE] walls, soil nail walls, or soldier pile walls).
- 6.8.10 Unrestrained walls will move laterally when backfilled and loading is applied. The amount of lateral deflection is dependent on the wall height, the type of soil used for backfill, and loads acting on the wall. The retaining walls and improvements above the retaining walls should be designed to incorporate an appropriate amount of lateral deflection as determined by the structural engineer.
- 6.8.11 Soil contemplated for use as retaining wall backfill, including imported soil, should be identified in the field prior to backfill. Geocon Incorporated should be provide with samples to evaluate its suitability. Modified lateral earth pressures may be necessary if the backfill soil does not meet the required expansion index or shear strength.
- 6.8.12 City or regional standard wall designs are based on a specific active lateral earth pressure and soil friction angle. The on-site soil may or may not meet the values for standard wall designs. Geocon Incorporated should be consulted to assess the suitability of the on-site soil for use as wall backfill if standard wall designs will be used.

6.9 Lateral Loading

- 6.9.1 Table 6.9 should be used to help design the proposed structures and improvements to resist lateral loads for the design of footings or shear keys. The allowable passive pressure assumes a horizontal surface extending at least 5 feet, or three times the surface generating the passive pressure, whichever is greater. The upper 12 inches of material in areas not protected by floor slabs or pavement should not be included in design for passive resistance.

**TABLE 6.9
SUMMARY OF LATERAL LOAD DESIGN RECOMMENDATIONS**

Parameter	Value
Passive Pressure Fluid Density	300 pcf
Coefficient of Friction (Concrete and Soil)	0.35
Coefficient of Friction (Along Vapor Barrier)	0.2 to 0.25*

*Per manufacturer's recommendations.

- 6.9.2 The passive and frictional resistant loads can be combined for design purposes. The lateral passive pressures may be increased by one-third when considering transient loads due to wind or seismic forces.

6.10 Storm Water Management

- 6.10.1 If storm water management devices are not properly designed and constructed, there is a risk for distress to improvements and properties located hydrologically down gradient or adjacent to these devices. Factors such as the amount of water being detained, its residence time, and soil permeability have an important effect on seepage transmission and the potential adverse impacts that may occur if the storm water management features are not properly designed and constructed. We have not performed a hydrogeological study at the site. If infiltration of storm water runoff into the subsurface occurs, downstream improvements may be subjected to seeps, springs, slope instability, raised groundwater, movement of foundations and slabs, or other undesirable impacts as a result of water infiltration.

- 6.10.2 We performed 4 borehole field-saturated, hydraulic conductivity tests at the site using a Soil Moisture Corp Aardvark Permeameter at the locations presented on the Geologic Map, Figure 1. Table 6.10.1 presents the results of the saturated hydraulic conductivity testing.

**TABLE 6.10.1
FIELD-SATURATED, INFILTRATION TEST RESULTS**

Test No.	Depth (inches)	Surficial Soil or Geologic Unit	Field Infiltration Rate, I (in/hr)	Factored* Field Infiltration Rate, I (in/hr)
A-1	65	Qt	0.322	0.161
A-2	60	Qt	0.027	0.0135
A-3	35.5	Topsoil/Qt	0.035	0.0175
A-4	66	Qt	0.063	0.0315

*Factor of Safety of 2.0 for feasibility determination.

- 6.10.3 We used the guidelines presented in the Riverside County Low Impact Development BMP Design Handbook which references the United States Bureau of Reclamation Well Permeameter Test Method (USBR 7300-89). Based on this widely accepted guideline, the saturated hydraulic conductivity (Ksat) is equal to the infiltration rate. Therefore, the Ksat value determined from the Aardvark Permeameter test is the unfactored infiltration rate. The Ksat (infiltration rate) equation provided in the Riverside County Handbook was used to compute the unfactored infiltration rate.
- 6.10.4 Soil permeability values from in-situ tests can vary significantly from one location to another due to the non-homogeneous characteristics inherent to most soil. However, if a sufficient amount of field and laboratory test data is obtained, a general trend of soil permeability can usually be evaluated. For this project and for storm water purposes, the test results presented herein should be considered approximate values.
- 6.10.5 Infiltration categories include full infiltration, partial infiltration and no infiltration. Table 6.10.2 presents the commonly accepted definitions of the potential infiltration categories based on the infiltration rates.

**TABLE 6.10.2
INFILTRATION CATEGORIES**

Infiltration Category	Field Infiltration Rate, I (inches/hour)	Factored Infiltration Rate*, I (inches/hour)
Full Infiltration	$I > 1.0$	$I > 0.5$
Partial Infiltration	$0.10 < I \leq 1.0$	$0.05 < I \leq 0.5$
No Infiltration (Infeasible)	$I < 0.10$	$I < 0.05$

*Using a Factor of Safety of 2.

- 6.10.6 We evaluated the site for areas of potential infiltration. The entire site is underlain by clayey Terrace Deposits. In the area of the proposed basin, the infiltration rates are sufficiently low that full or partial infiltration is not feasible. Additionally, the clayey Terrace Deposits are highly expansive. Infiltrating into the expansive soils could cause soil movement and associated distress to adjacent improvements. Based on our exploratory borings, we do not expect other areas on the site will have infiltration characteristics that are significantly higher and suitable for infiltration.
- 6.10.7 In our professional opinion and based on our site-specific investigation, there are no areas of the site where storm water infiltration is feasible. The infiltration rates are too low and/or there is an un-mitigatable risk of lateral flow to adjacent rights-of-way, utility trenches, and future buildings.

6.11 Site Drainage and Moisture Protection

- 6.11.1 Adequate site drainage is critical to reduce potential differential soil movement; erosion; and subsurface seepage. Under no circumstances should water be allowed to pond adjacent to footings. The site should be graded and maintained such that surface drainage is directed away from structures in accordance with 2022 CBC 1804.4. Surface drainage should be directed away from the top of slopes into swales or other controlled drainage devices. Roof and pavement drainage should be directed into conduits that carry runoff away from the proposed structure.
- 6.11.2 In the case of basement walls or building walls retaining landscaping areas, a water-proofing system should be used on the wall and joints, and a Miradrain drainage panel (or similar) should be placed over the waterproofing. The project architect or civil engineer should provide detailed specifications on the plans for all waterproofing and drainage.
- 6.11.3 Underground utilities must be leak free. Utility and irrigation lines should be checked at appropriate intervals for leaks. Detected leaks should be promptly repaired. Detrimental soil movement could occur if water is allowed to infiltrate the soil.
- 6.11.4 Landscaping planters adjacent to paved areas are not recommended due to the risk of surface or irrigation water infiltrating the pavement subgrade and base course. Area drains to collect and transmit excess irrigation water into drainage structures and impervious above-grade planter boxes can be used. A cutoff wall along the edge of the pavement extending at least 6 inches below the bottom of the base material should be considered.

6.12 Grading and Foundation Plan Review

- 6.12.1 Geocon Incorporated should review the grading and foundation plans for the project prior to final design submittal to determine if additional analysis and/or recommendations are required.

LIMITATIONS AND UNIFORMITY OF CONDITIONS

1. The firm that performed the geotechnical investigation for the project should be retained to provide testing and observation services during construction to provide continuity of geotechnical interpretation and to check that the recommendations presented for geotechnical aspects of site development are incorporated during site grading, construction of improvements, and excavation of foundations. If another geotechnical firm is selected to perform the testing and observation services during construction operations, that firm should prepare a letter indicating their intent to assume the responsibilities of project geotechnical engineer of record. A copy of the letter should be provided to the regulatory agency for their records. In addition, that firm should provide revised recommendations concerning the geotechnical aspects of the proposed development, or a written acknowledgement of their concurrence with the recommendations presented in our report. They should also perform additional analyses deemed necessary to assume the role of Geotechnical Engineer of Record.
2. The recommendations of this report pertain only to the site investigated and are based upon the assumption that the soil conditions do not deviate from those disclosed in the investigation. If any variations or undesirable conditions are encountered during construction, or if the proposed construction will differ from that anticipated herein, Geocon Incorporated should be notified so that supplemental recommendations can be given. The evaluation or identification of the potential presence of hazardous or corrosive materials was not part of the scope of services provided by Geocon Incorporated.
3. This report is issued with the understanding that it is the responsibility of the owner or his representative to ensure that the information and recommendations contained herein are brought to the attention of the architect and engineer for the project and incorporated into the plans, and the necessary steps are taken to see that the contractor and subcontractors carry out such recommendations in the field.
4. The findings of this report are valid as of the present date. However, changes in the conditions of a property can occur with the passage of time, whether they be due to natural processes or the works of man on this or adjacent properties. In addition, changes in applicable or appropriate standards may occur, whether they result from legislation or the broadening of knowledge. Accordingly, the findings of this report may be invalidated wholly or partially by changes outside our control. Therefore, this report is subject to review and should not be relied upon after a period of three years.

THE COLLECTION AT CACTUS
SAN DIEGO, CALIFORNIA

APPROX. LIMITS OF SITE



0' 75' 150' 225' 300'
SCALE 1"=150' (on 11x17)

GEOCON LEGEND

- Qtc** TERRACE DEPOSITS - CLAY MEMBER
- Qtg** TERRACE DEPOSITS - SAND/GRAVEL MEMBER
- APPROX. LOCATION OF GEOLOGIC CONTACT (Queried Where Uncertain)
- B-3** APPROX. LOCATION OF PRELIMINARY BORING
- A-4** APPROX. LOCATION OF INFILTRATION TESTING
- TP16** APPROX. LOCATION OF EXPLORATORY TEST PIT
- (5)** APPROX. DEPTH (in Feet) TO CONTACT BETWEEN Qtc AND Qtg

GEOCON
INCORPORATED
GEO TECHNICAL ■ ENVIRONMENTAL ■ MATERIALS
6960 FLANDERS DRIVE - SAN DIEGO, CALIFORNIA 92121 - 2974
PHONE 619 558-6900 - FAX 619 558-6159
PROJECT NO. G2338 - 42 - 02

FIGURE 1
GEOLOGIC MAP DATE 05 - 18 - 2023

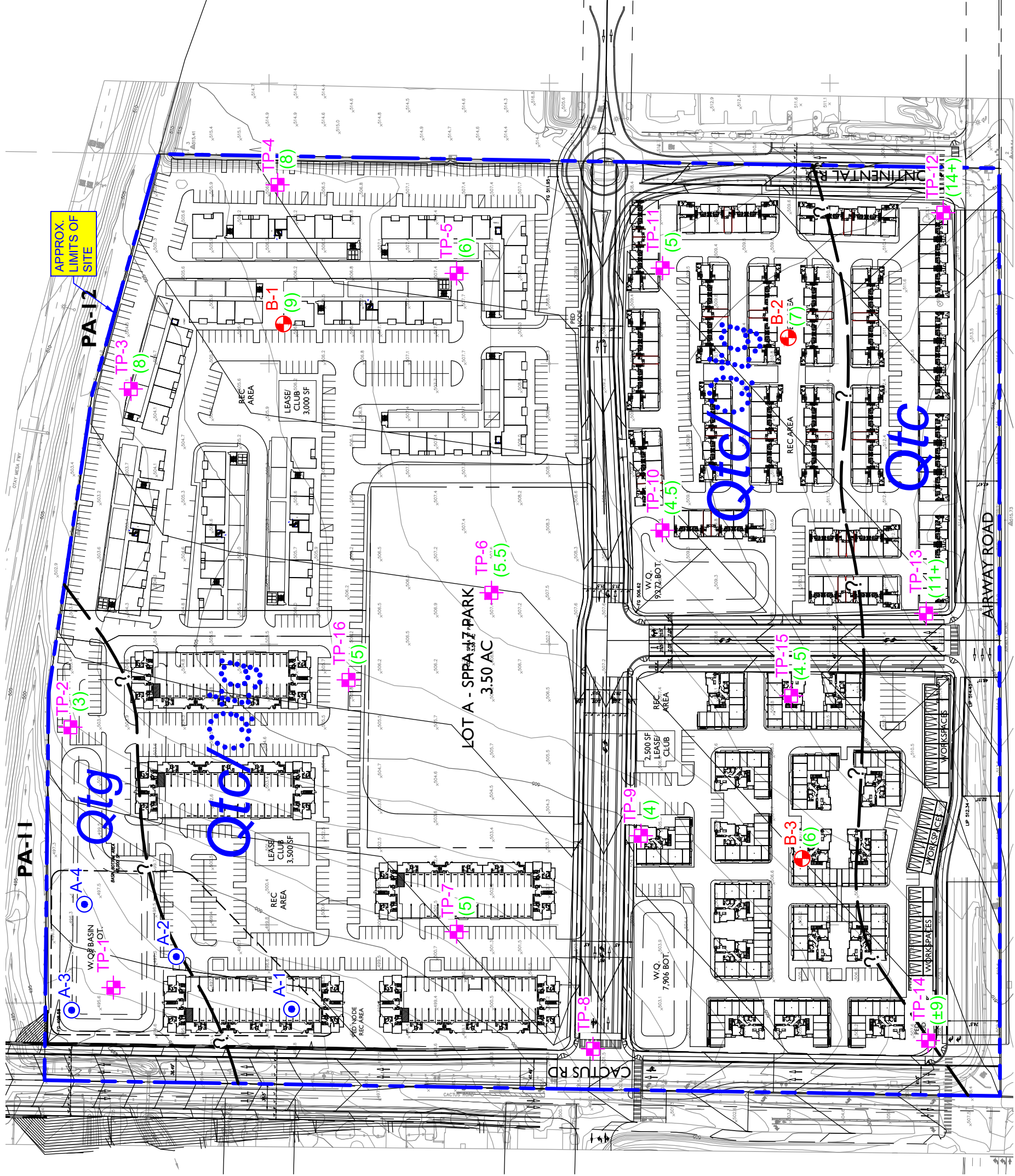

APPENDIX

A

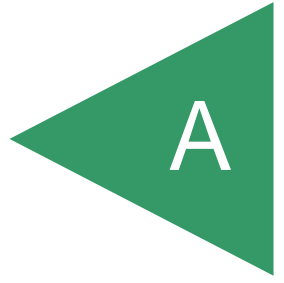

APPENDIX A

PREVIOUS FIELD INVESTIGATIONS

We performed field investigations on November 27, 2018, and March 8, 2019. The investigations consisted of drilling three, small-diameter borings, excavating four infiltration-test borings, and excavating 16 backhoe trenches. The approximate locations of the previous exploratory trenches, borings and infiltration tests are shown on the Geologic Map, Figure 1.

The geotechnical borings were drilled to depths of approximately 10 feet below existing grade using a CME 95 drill rig equipped with hollow-stem augers. The infiltration-test borings were drilled to depths of approximately 4.5 to 6 feet.

The exploratory trenches were excavated to a maximum depth of 16 feet below existing grades using a John Deere 555 backhoe equipped with a 24-inch-wide bucket. Bulk samples were obtained for laboratory testing.

The soil conditions encountered in the excavations were visually classified and logged in general accordance with American Society for Testing and Materials (ASTM) practice for Description and Identification of Soils (Visual Manual Procedure D 2488). The logs of the previous trenches are presented on Figures A-1 through A-16 and the logs of previous borings performed are presented on Figures A-17 through A-19.







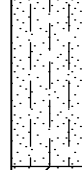
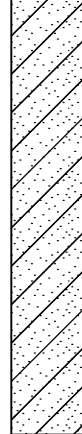

DEPTH IN FEET	SAMPLE NO.	LITHOLOGY	GROUNDWATER	SOIL CLASS (USCS)	BORING B 1		PENETRATION RESISTANCE (BLOWS/FT.)	DRY DENSITY (P.C.F.)	MOISTURE CONTENT (%)
					ELEV. (MSL.) <u>506'</u>	DATE COMPLETED <u>11-27-2018</u>			
					EQUIPMENT <u>CME 95</u>		BY: <u>N. BORJA</u>		
MATERIAL DESCRIPTION									
0				SM/SC	TOPSOIL Loose, dry to damp, dark brown, Silty to Clayey, fine to coarse SAND				
2				CL	TERRACE DEPOSITS-CLAY MEMBER (Qtc) Firm, moist, dark olive brown, Sandy CLAY				
4									
6									
8									
10				SM	TERRACE DEPOSITS-GRAVEL MEMBER (Qtg) Medium dense, damp, tan brown, Silty, fine to coarse SAND				
					BORING TERMINATED AT 10 FEET Groundwater not encountered				

Figure A-17,
Log of Boring B 1, Page 1 of 1

G2338-42-01 (BORING AND TEST PIT).GPJ

SAMPLE SYMBOLS		... SAMPLING UNSUCCESSFUL		... STANDARD PENETRATION TEST		... DRIVE SAMPLE (UNDISTURBED)
		... DISTURBED OR BAG SAMPLE		... CHUNK SAMPLE		... WATER TABLE OR SEEPAGE

NOTE: THE LOG OF SUBSURFACE CONDITIONS SHOWN HEREON APPLIES ONLY AT THE SPECIFIC BORING OR TRENCH LOCATION AND AT THE DATE INDICATED. IT IS NOT WARRANTED TO BE REPRESENTATIVE OF SUBSURFACE CONDITIONS AT OTHER LOCATIONS AND TIMES.







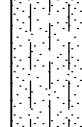
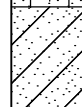

DEPTH IN FEET	SAMPLE NO.	LITHOLOGY	GROUNDWATER	SOIL CLASS (USCS)	BORING B 2		PENETRATION RESISTANCE (BLOWS/FT.)	DRY DENSITY (P.C.F.)	MOISTURE CONTENT (%)
					ELEV. (MSL.) <u>511'</u>	DATE COMPLETED <u>11-27-2018</u>			
					EQUIPMENT <u>CME 95</u> BY: <u>N. BORJA</u>				
					MATERIAL DESCRIPTION				
0				SM	TOPSOIL Loose, dry, dark grayish brown, Silty, fine to medium SAND				
2				CL	TERRACE DEPOSITS-CLAY MEMBER (Qtc) Firm, damp, dark olive brown, Sandy CLAY				
4				SC	Loose to medium dense, damp, very light gray, Clayey, fine to medium SAND				
6									
8				SM	TERRACE DEPOSITS-GRAVEL MEMBER (Qtg) Medium dense, dry, tan brown, Silty, fine to coarse SAND				
					-Excavates with gravel at 9 feet				
					BORING TERMINATED AT 9.5 FEET Groundwater not encountered				

Figure A-18,
Log of Boring B 2, Page 1 of 1

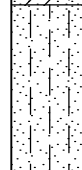
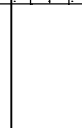
G2338-42-01 (BORING AND TEST PIT).GPJ

SAMPLE SYMBOLS	 ... SAMPLING UNSUCCESSFUL	 ... STANDARD PENETRATION TEST	 ... DRIVE SAMPLE (UNDISTURBED)
	 ... DISTURBED OR BAG SAMPLE	 ... CHUNK SAMPLE	 ... WATER TABLE OR SEEPAGE

NOTE: THE LOG OF SUBSURFACE CONDITIONS SHOWN HEREON APPLIES ONLY AT THE SPECIFIC BORING OR TRENCH LOCATION AND AT THE DATE INDICATED. IT IS NOT WARRANTED TO BE REPRESENTATIVE OF SUBSURFACE CONDITIONS AT OTHER LOCATIONS AND TIMES.

DEPTH IN FEET	SAMPLE NO.	LITHOLOGY	GROUNDWATER	SOIL CLASS (USCS)	BORING B 3		PENETRATION RESISTANCE (BLOWS/FT.)	DRY DENSITY (P.C.F.)	MOISTURE CONTENT (%)
					ELEV. (MSL.) <u>507.5'</u>	DATE COMPLETED <u>11-27-2018</u>			
					EQUIPMENT <u>CME 95</u> BY: <u>N. BORJA</u>				
MATERIAL DESCRIPTION									
0				SM	TOPSOIL Loose, dry, dark grayish brown, Silty, fine to coarse SAND				
2				CL	TERRACE DEPOSITS-CLAY MEMBER (Qtc) Firm, damp, olive brown, Sandy CLAY				
4				SM	Loose to medium dense, damp, grayish brown to brown, Silty, fine to medium SAND				
6				SM	TERRACE DEPOSITS-GRAVEL MEMBER (Qtg) Dense to very dense, dry, light brown to yellowish brown, Silty, fine to coarse SAND; little gravel				
					REFUSAL AT 7.5 FEET Groundwater not encountered				

Figure A-19,
Log of Boring B 3, Page 1 of 1

G2338-42-01 (BORING AND TEST PIT).GPJ

SAMPLE SYMBOLS	... SAMPLING UNSUCCESSFUL	... STANDARD PENETRATION TEST	... DRIVE SAMPLE (UNDISTURBED)
	... DISTURBED OR BAG SAMPLE	... CHUNK SAMPLE	... WATER TABLE OR SEEPAGE

NOTE: THE LOG OF SUBSURFACE CONDITIONS SHOWN HEREON APPLIES ONLY AT THE SPECIFIC BORING OR TRENCH LOCATION AND AT THE DATE INDICATED. IT IS NOT WARRANTED TO BE REPRESENTATIVE OF SUBSURFACE CONDITIONS AT OTHER LOCATIONS AND TIMES.

DEPTH IN FEET	SAMPLE NO.	LITHOLOGY	GROUNDWATER	SOIL CLASS (USCS)	TEST PIT TP 1		PENETRATION RESISTANCE (BLOWS/FT.)	DRY DENSITY (P.C.F.)	MOISTURE CONTENT (%)
					ELEV. (MSL.) <u>497'</u>	DATE COMPLETED <u>03-08-2019</u>			
					EQUIPMENT <u>Backhoe</u> BY: <u>R. ADAMS</u>				
					MATERIAL DESCRIPTION				
0	TP1-1			CL	TOPSOIL (Ts) Soft, moist, dark brown, Sandy CLAY; trace silt				
2				SC	TERRACE DEPOSITS-Sand/Gravel Member (Qtg) Medium dense, damp to moist, pale yellowish brown, Clayey, fine grained SAND				
4	TP1-2				-Becomes medium- to coarse-grained, trace cobble, trace silt				
6				SC	Dense, damp, yellowish brown, medium- to coarse-grained SAND; trace clay, trace subrounded cobble				
8					TRENCH TERMINATED AT 9 FEET Groundwater not encountered Backfilled 03-08-2019				

Figure A-1,
Log of Test Pit TP 1, Page 1 of 1

G2338-42-01 (BORING AND TEST PIT).GPJ

SAMPLE SYMBOLS		... SAMPLING UNSUCCESSFUL		... STANDARD PENETRATION TEST		... DRIVE SAMPLE (UNDISTURBED)
		... DISTURBED OR BAG SAMPLE		... CHUNK SAMPLE		... WATER TABLE OR SEEPAGE

NOTE: THE LOG OF SUBSURFACE CONDITIONS SHOWN HEREON APPLIES ONLY AT THE SPECIFIC BORING OR TRENCH LOCATION AND AT THE DATE INDICATED. IT IS NOT WARRANTED TO BE REPRESENTATIVE OF SUBSURFACE CONDITIONS AT OTHER LOCATIONS AND TIMES.

DEPTH IN FEET	SAMPLE NO.	LITHOLOGY	GROUNDWATER	SOIL CLASS (USCS)	TEST PIT TP 2		PENETRATION RESISTANCE (BLOWS/FT.)	DRY DENSITY (P.C.F.)	MOISTURE CONTENT (%)
					ELEV. (MSL.) <u>503'</u>	DATE COMPLETED <u>03-08-2019</u>			
					EQUIPMENT <u>Backhoe</u>		BY: <u>R. ADAMS</u>		
MATERIAL DESCRIPTION									
0	TP1-1			CL	TOPSOIL (Ts) Soft to moist, wet, dark brown to black, Sandy CLAY				
2				SC	TERRACE DEPOSITS-Sand/Gravel Member (Qtg) Medium dense to dense, damp, yellowish brown, Clayey, medium coarse SAND; trace cobble, pockets of dark brown, Sandy CLAY throughout				
4				SM	Dense, damp, pale brown to yellowish brown, Silty, fine to coarse SAND; trace clay, trace sub-rounded cobble up to 10-inch diameter				
6					-Becomes weakly cemented; excavating to a clayey sand with gravel and cobble				
8									
10									
12					TRENCH TERMINATED AT 12 FEET Groundwater not encountered Backfilled 03-08-2019				

Figure A-2,
Log of Test Pit TP 2, Page 1 of 1

G2338-42-01 (BORING AND TEST PIT).GPJ

SAMPLE SYMBOLS	... SAMPLING UNSUCCESSFUL	... STANDARD PENETRATION TEST	... DRIVE SAMPLE (UNDISTURBED)
	... DISTURBED OR BAG SAMPLE	... CHUNK SAMPLE	... WATER TABLE OR SEEPAGE

NOTE: THE LOG OF SUBSURFACE CONDITIONS SHOWN HEREON APPLIES ONLY AT THE SPECIFIC BORING OR TRENCH LOCATION AND AT THE DATE INDICATED. IT IS NOT WARRANTED TO BE REPRESENTATIVE OF SUBSURFACE CONDITIONS AT OTHER LOCATIONS AND TIMES.













DEPTH IN FEET	SAMPLE NO.	LITHOLOGY	GROUNDWATER	SOIL CLASS (USCS)	TEST PIT TP 3		PENETRATION RESISTANCE (BLOWS/FT.)	DRY DENSITY (P.C.F.)	MOISTURE CONTENT (%)
					ELEV. (MSL.) <u>504'</u>	DATE COMPLETED <u>03-08-2019</u>			
					EQUIPMENT <u>Backhoe</u> BY: <u>R. ADAMS</u>				
MATERIAL DESCRIPTION									
0				CH	TOPSOIL (Ts) Soft to firm, moist, grayish brown to black, Silty CLAY; trace sand				
2				CH	TERRACE DEPOSITS-Clay Member (Qtc) Firm to stiff, moist, grayish brown, Sandy CLAY; trace rock fragments, trace sand				
4	TP3-1								
6				CH	Very stiff, moist, grayish brown to reddish brown, Sandy CLAY				
8	TP3-2								
10				SM	TERRACE DEPOSITS-Sand/Gravel Member (Qtg) Dense, damp, reddish brown to grayish brown (mottled), Silty, fine to medium SAND; trace clay, trace cobble up to 6-inch diameter				
12					TRENCH TERMINATED AT 12 FEET Groundwater not encountered Backfilled 03-08-2019				

Figure A-3,
Log of Test Pit TP 3, Page 1 of 1

G2338-42-01 (BORING AND TEST PIT).GPJ







SAMPLE SYMBOLS		... SAMPLING UNSUCCESSFUL		... STANDARD PENETRATION TEST		... DRIVE SAMPLE (UNDISTURBED)
		... DISTURBED OR BAG SAMPLE		... CHUNK SAMPLE		... WATER TABLE OR SEEPAGE

NOTE: THE LOG OF SUBSURFACE CONDITIONS SHOWN HEREON APPLIES ONLY AT THE SPECIFIC BORING OR TRENCH LOCATION AND AT THE DATE INDICATED. IT IS NOT WARRANTED TO BE REPRESENTATIVE OF SUBSURFACE CONDITIONS AT OTHER LOCATIONS AND TIMES.

DEPTH IN FEET	SAMPLE NO.	LITHOLOGY	GROUNDWATER	SOIL CLASS (USCS)	TEST PIT TP 4		PENETRATION RESISTANCE (BLOWS/FT.)	DRY DENSITY (P.C.F.)	MOISTURE CONTENT (%)
					ELEV. (MSL.) <u>506'</u>	DATE COMPLETED <u>03-08-2019</u>			
					EQUIPMENT <u>Backhoe</u>		BY: <u>R. ADAMS</u>		
MATERIAL DESCRIPTION									
0				CH	TOPSOIL (Ts) Soft, wet, brown to grayish brown, CLAY; trace silt; trace sand				
2									
4				CH	TERRACE DEPOSITS-Clay Member (Qtc) Firm to stiff, damp to moist, brownish gray, CLAY -Becomes stiff to very stiff, on blocky texture, manganese films noted on parking surfaces				
6									
8				SC	TERRACE DEPOSITS-Sand/Gravel (Qtg) Medium dense to dense, damp, reddish brown to grayish brown (mottled), Clayey, fine- to medium-grained SAND; trace silt				
10				SM	Dense, damp, grayish brown, Silty, medium to coarse SAND; trace clay; some gravel/cobble up to 10-inch diameter				
					TRENCH TERMINATED AT 11 FEET Groundwater not encountered Backfilled 03-08-2019				

Figure A-4,
Log of Test Pit TP 4, Page 1 of 1

G2338-42-01 (BORING AND TEST PIT).GPJ

SAMPLE SYMBOLS	 ... SAMPLING UNSUCCESSFUL	 ... STANDARD PENETRATION TEST	 ... DRIVE SAMPLE (UNDISTURBED)
	 ... DISTURBED OR BAG SAMPLE	 ... CHUNK SAMPLE	 ... WATER TABLE OR SEEPAGE

NOTE: THE LOG OF SUBSURFACE CONDITIONS SHOWN HEREON APPLIES ONLY AT THE SPECIFIC BORING OR TRENCH LOCATION AND AT THE DATE INDICATED. IT IS NOT WARRANTED TO BE REPRESENTATIVE OF SUBSURFACE CONDITIONS AT OTHER LOCATIONS AND TIMES.







DEPTH IN FEET	SAMPLE NO.	LITHOLOGY	GROUNDWATER	SOIL CLASS (USCS)	TEST PIT TP 5		PENETRATION RESISTANCE (BLOWS/FT.)	DRY DENSITY (P.C.F.)	MOISTURE CONTENT (%)
					ELEV. (MSL.) <u>507'</u>	DATE COMPLETED <u>03-08-2019</u>			
					EQUIPMENT <u>Backhoe</u> BY: <u>R. ADAMS</u>				
					MATERIAL DESCRIPTION				
0	TP5-1			CH	TOPSOIL (Ts) Soft, damp to wet, brown, CLAY; trace sand; few rootlets				
2	TP5-2			CH	TERRACE DEPOSITS-Clay Member (Qtc) Firm to stiff, damp to moist, whitish gray, CLAY				
4									
6									
6	TP5-3			SM	TERRACE DEPOSITS-Sand/Gravel Member (Qtg) Dense, damp, pale yellowish gray, Silty, coarse SAND; trace small cobble				
8									
					TRENCH TERMINATED AT 9 FEET Groundwater not encountered Backfilled 03-08-2019				

Figure A-5,
Log of Test Pit TP 5, Page 1 of 1

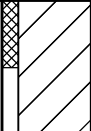
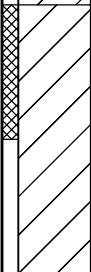
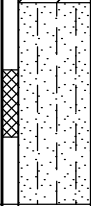
G2338-42-01 (BORING AND TEST PIT).GPJ

SAMPLE SYMBOLS		... SAMPLING UNSUCCESSFUL		... STANDARD PENETRATION TEST		... DRIVE SAMPLE (UNDISTURBED)
		... DISTURBED OR BAG SAMPLE		... CHUNK SAMPLE		... WATER TABLE OR SEEPAGE

NOTE: THE LOG OF SUBSURFACE CONDITIONS SHOWN HEREON APPLIES ONLY AT THE SPECIFIC BORING OR TRENCH LOCATION AND AT THE DATE INDICATED. IT IS NOT WARRANTED TO BE REPRESENTATIVE OF SUBSURFACE CONDITIONS AT OTHER LOCATIONS AND TIMES.









DEPTH IN FEET	SAMPLE NO.	LITHOLOGY	GROUNDWATER	SOIL CLASS (USCS)	TEST PIT TP 6		PENETRATION RESISTANCE (BLOWS/FT.)	DRY DENSITY (P.C.F.)	MOISTURE CONTENT (%)
					ELEV. (MSL.) <u>507'</u>	DATE COMPLETED <u>03-08-2019</u>			
					EQUIPMENT <u>Backhoe</u> BY: <u>R. ADAMS</u>				
MATERIAL DESCRIPTION									
0	TP6-1			CH	TOPSOIL (Ts) Very soft to soft, wet, grayish brown to brown, CLAY				
2				SC	TERRACE DEPOSITS-Clay Member (Qtc) Firm to stiff, damp to moist, grayish brown, Sandy CLAY; trace rounded gravel -Becomes hard and blocky, trace carbonate and manganese				
4				CH	Hard, dry to damp, yellowish brown, Sandy CLAY				
6				SM	TERRACE DEPOSITS-Sand/Gravel Member (Qtg) Dense, dry to damp, yellowish brown, Silty, fine to coarse SAND; trace small cobble, angular to sub-rounded -Becomes reddish brown				
8									
10					TRENCH TERMINATED AT 10 FEET Groundwater not encountered Backfilled 03-08-2019				

Figure A-6,
Log of Test Pit TP 6, Page 1 of 1

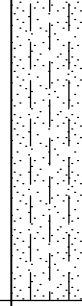
G2338-42-01 (BORING AND TEST PIT).GPJ







SAMPLE SYMBOLS		... SAMPLING UNSUCCESSFUL		... STANDARD PENETRATION TEST		... DRIVE SAMPLE (UNDISTURBED)
		... DISTURBED OR BAG SAMPLE		... CHUNK SAMPLE		... WATER TABLE OR SEEPAGE

NOTE: THE LOG OF SUBSURFACE CONDITIONS SHOWN HEREON APPLIES ONLY AT THE SPECIFIC BORING OR TRENCH LOCATION AND AT THE DATE INDICATED. IT IS NOT WARRANTED TO BE REPRESENTATIVE OF SUBSURFACE CONDITIONS AT OTHER LOCATIONS AND TIMES.

DEPTH IN FEET	SAMPLE NO.	LITHOLOGY	GROUNDWATER	SOIL CLASS (USCS)	TEST PIT TP 7		PENETRATION RESISTANCE (BLOWS/FT.)	DRY DENSITY (P.C.F.)	MOISTURE CONTENT (%)
					ELEV. (MSL.) <u>501'</u>	DATE COMPLETED <u>03-08-2019</u>			
					EQUIPMENT <u>Backhoe</u>		BY: <u>R. ADAMS</u>		
MATERIAL DESCRIPTION									
0				CH	TOPSOIL (Ts) Stiff, firm, damp to moist, dark brown, Silty CLAY; trace plastic debris				
2									
4				CH	TERRACE DEPOSITS-Clay Member (Qtc) Stiff to hard, dry to damp, whitish gray to grayish brown, Sandy CLAY				
6				SC	TERRACE DEPOSITS-Sand/Gravel Member (Qtg) Dense, damp, yellowish gray to yellowish brown, Clayey, medium coarse SAND; trace cobble up to 8-inch diameter				
8					-Becomes reddish brown				
10					-Becomes very dense, little cobble and rock fragments up to 12-inch diameter				
12					-Becomes reddish brown to greenish brown (mottled); Cobble up to 20-inch diameter				
14	TP7-1			SC/CL	Dense, damp, yellowish brown, greenish gray (mottled), Clayey SAND and Sandy CLAY (Interbedded); some cobble up to 10-inch diameter				
16					TRENCH TERMINATED AT 16 FEET Groundwater not encountered Backfilled 03-08-2019				

Figure A-7,
Log of Test Pit TP 7, Page 1 of 1

G2338-42-01 (BORING AND TEST PIT).GPJ

SAMPLE SYMBOLS	 ... SAMPLING UNSUCCESSFUL	 ... STANDARD PENETRATION TEST	 ... DRIVE SAMPLE (UNDISTURBED)
	 ... DISTURBED OR BAG SAMPLE	 ... CHUNK SAMPLE	 ... WATER TABLE OR SEEPAGE

NOTE: THE LOG OF SUBSURFACE CONDITIONS SHOWN HEREON APPLIES ONLY AT THE SPECIFIC BORING OR TRENCH LOCATION AND AT THE DATE INDICATED. IT IS NOT WARRANTED TO BE REPRESENTATIVE OF SUBSURFACE CONDITIONS AT OTHER LOCATIONS AND TIMES.







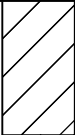

DEPTH IN FEET	SAMPLE NO.	LITHOLOGY	GROUNDWATER	SOIL CLASS (USCS)	TEST PIT TP 8		PENETRATION RESISTANCE (BLOWS/FT.)	DRY DENSITY (P.C.F.)	MOISTURE CONTENT (%)
					ELEV. (MSL.) <u>501'</u>	DATE COMPLETED <u>03-08-2019</u>			
					EQUIPMENT <u>Backhoe</u>		BY: <u>R. ADAMS</u>		
MATERIAL DESCRIPTION									
0				CH	TOPSOIL (Ts) Firm, damp, brownish black, CLAY; trace sand				
2				CH	TERRACE DEPOSITS-Clay (Qtc) Stiff to hard, damp grayish yellow (mottled), Sandy CLAY; trace cobble				
4				SC	TERRACE DEPOSITS-Sand/Gravel Member (Qtg) Dense, damp, reddish brown to grayish brown, Clayey SAND; trace cobble up to 8-inch diameter -Becomes dense to very dense, reddish brown; some cobble up to 6-inch diameter				
6					TRENCH TERMINATED AT 6 FEET Groundwater not encountered Backfilled 03-08-2019				

Figure A-8,
Log of Test Pit TP 8, Page 1 of 1

G2338-42-01 (BORING AND TEST PIT).GPJ

SAMPLE SYMBOLS	 ... SAMPLING UNSUCCESSFUL	 ... STANDARD PENETRATION TEST	 ... DRIVE SAMPLE (UNDISTURBED)
	 ... DISTURBED OR BAG SAMPLE	 ... CHUNK SAMPLE	 ... WATER TABLE OR SEEPAGE

NOTE: THE LOG OF SUBSURFACE CONDITIONS SHOWN HEREON APPLIES ONLY AT THE SPECIFIC BORING OR TRENCH LOCATION AND AT THE DATE INDICATED. IT IS NOT WARRANTED TO BE REPRESENTATIVE OF SUBSURFACE CONDITIONS AT OTHER LOCATIONS AND TIMES.









DEPTH IN FEET	SAMPLE NO.	LITHOLOGY	GROUNDWATER	SOIL CLASS (USCS)	TEST PIT TP 9		PENETRATION RESISTANCE (BLOWS/FT.)	DRY DENSITY (P.C.F.)	MOISTURE CONTENT (%)
					ELEV. (MSL.) <u>505'</u>	DATE COMPLETED <u>03-08-2019</u>			
					EQUIPMENT <u>Backhoe</u> BY: <u>R. ADAMS</u>				
MATERIAL DESCRIPTION									
0	TP9-1			CH	TOPSOIL (Ts) Firm to stiff, moist, dark brown, CLAY; trace sand				
2				CH	TERRACE DEPOSITS-Clay Member (Qtc) Stiff, damp, grayish brown, CLAY; trace sand, trace carbonate				
4				SC	TERRACE DEPOSITS-Sand/Gravel Member (Qtg) Dense, damp, yellowish brown, Clayey, medium to coarse SAND; trace cobble and gravel up to 6-inch diameter -Little cobble up to 8-inch diameter				
6					TRENCH TERMINATED AT 7 FEET Groundwater not encountered Backfilled 03-08-2019				

Figure A-9,
Log of Test Pit TP 9, Page 1 of 1

G2338-42-01 (BORING AND TEST PIT).GPJ

SAMPLE SYMBOLS	 ... SAMPLING UNSUCCESSFUL	 ... STANDARD PENETRATION TEST	 ... DRIVE SAMPLE (UNDISTURBED)
	 ... DISTURBED OR BAG SAMPLE	 ... CHUNK SAMPLE	 ... WATER TABLE OR SEEPAGE

NOTE: THE LOG OF SUBSURFACE CONDITIONS SHOWN HEREON APPLIES ONLY AT THE SPECIFIC BORING OR TRENCH LOCATION AND AT THE DATE INDICATED. IT IS NOT WARRANTED TO BE REPRESENTATIVE OF SUBSURFACE CONDITIONS AT OTHER LOCATIONS AND TIMES.









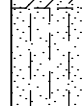

DEPTH IN FEET	SAMPLE NO.	LITHOLOGY	GROUNDWATER	SOIL CLASS (USCS)	TEST PIT TP 10		PENETRATION RESISTANCE (BLOWS/FT.)	DRY DENSITY (P.C.F.)	MOISTURE CONTENT (%)
					ELEV. (MSL.) <u>509'</u>	DATE COMPLETED <u>03-08-2019</u>			
					EQUIPMENT <u>Backhoe</u> BY: <u>R. ADAMS</u>				
MATERIAL DESCRIPTION									
0				CH	TOPSOIL (Ts) Soft, moist to wet, brownish black, CLAY; trace carbonate				
2				CH	TERRACE DEPOSITS-Clay Member (Qtc) Firm to stiff, damp, brown to grayish brown, Sandy CLAY; trace cobble				
4				SC	TERRACE DEPOSITS-Sand/Gravel Member (Qtg) Medium dense to dense, grayish brown to pale yellowish brown, Clayey SAND; trace cobble				
6	TP10-1								
8				SM-SW	Medium dense to dense, grayish brown to dark brown, Silty, medium to coarse SAND; trace cobble, friable with low cohesion				
10					TRENCH TERMINATED AT 10 FEET Groundwater not encountered Backfilled 03-08-2019				

Figure A-10,
Log of Test Pit TP 10, Page 1 of 1

G2338-42-01 (BORING AND TEST PIT).GPJ

SAMPLE SYMBOLS		... SAMPLING UNSUCCESSFUL		... STANDARD PENETRATION TEST		... DRIVE SAMPLE (UNDISTURBED)
		... DISTURBED OR BAG SAMPLE		... CHUNK SAMPLE		... WATER TABLE OR SEEPAGE

NOTE: THE LOG OF SUBSURFACE CONDITIONS SHOWN HEREON APPLIES ONLY AT THE SPECIFIC BORING OR TRENCH LOCATION AND AT THE DATE INDICATED. IT IS NOT WARRANTED TO BE REPRESENTATIVE OF SUBSURFACE CONDITIONS AT OTHER LOCATIONS AND TIMES.







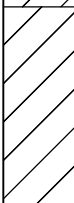

DEPTH IN FEET	SAMPLE NO.	LITHOLOGY	GROUNDWATER	SOIL CLASS (USCS)	TEST PIT TP 11		PENETRATION RESISTANCE (BLOWS/FT.)	DRY DENSITY (P.C.F.)	MOISTURE CONTENT (%)
					ELEV. (MSL.) <u>509'</u>	DATE COMPLETED <u>03-08-2019</u>			
					EQUIPMENT <u>Backhoe</u>		BY: <u>R. ADAMS</u>		
MATERIAL DESCRIPTION									
0				CH	TOPSOIL (Ts) Soft to firm, moist, dark brown to black, CLAY				
2				CH	TERRACE DEPOSITS-Clay Member (Qtc) Firm, damp, brownish gray, CLAY; trace sand; trace carbonate				
4				SC	TERRACE DEPOSITS-Sand/Gravel Member (Qtg) Medium dense to dense, damp, pale yellowish brown, Clayey, fine to medium SAND; trace cobble				
6				SM	Dense, damp, dark brown, Silty, medium to coarse SAND				
8					TRENCH TERMINATED AT 8 FEET Groundwater not encountered Backfilled 03-08-2019				

Figure A-11,
Log of Test Pit TP 11, Page 1 of 1

G2338-42-01 (BORING AND TEST PIT).GPJ

SAMPLE SYMBOLS		... SAMPLING UNSUCCESSFUL		... STANDARD PENETRATION TEST		... DRIVE SAMPLE (UNDISTURBED)
		... DISTURBED OR BAG SAMPLE		... CHUNK SAMPLE		... WATER TABLE OR SEEPAGE

NOTE: THE LOG OF SUBSURFACE CONDITIONS SHOWN HEREON APPLIES ONLY AT THE SPECIFIC BORING OR TRENCH LOCATION AND AT THE DATE INDICATED. IT IS NOT WARRANTED TO BE REPRESENTATIVE OF SUBSURFACE CONDITIONS AT OTHER LOCATIONS AND TIMES.

DEPTH IN FEET	SAMPLE NO.	LITHOLOGY	GROUNDWATER	SOIL CLASS (USCS)	TEST PIT TP 12			PENETRATION RESISTANCE (BLOWS/FT.)	DRY DENSITY (P.C.F.)	MOISTURE CONTENT (%)
					ELEV. (MSL.) <u>511'</u>	DATE COMPLETED <u>03-08-2019</u>	EQUIPMENT <u>Backhoe</u> BY: <u>R. ADAMS</u>			
					MATERIAL DESCRIPTION					
0				CH	TOPSOIL (Ts) Soft, wet, brown, CLAY					
2	TP12-1			SC	Medium dense, dry to damp, whitish brown, Clayey, fine to coarse SAND; abundant caliche; trace gravel					
4	TP12-2			CH	TERRACE DEPOSITS-Clay Member (Qtc) Firm to stiff, damp, reddish gray, Sandy CLAY; blocky texture; manganese films along fractures					
6										
8					-Mottled (red gray)					
10				CL	Stiff to very hard, dry to damp, reddish gray and greenish gray (mottled) Silty CLAY					
12	TP12-3									
14					TRENCH TERMINATED AT 14 FEET Groundwater not encountered Backfilled 03-08-2019					

Figure A-12,
Log of Test Pit TP 12, Page 1 of 1

G2338-42-01 (BORING AND TEST PIT).GPJ







SAMPLE SYMBOLS	... SAMPLING UNSUCCESSFUL	... STANDARD PENETRATION TEST	... DRIVE SAMPLE (UNDISTURBED)
	... DISTURBED OR BAG SAMPLE	... CHUNK SAMPLE	... WATER TABLE OR SEEPAGE

NOTE: THE LOG OF SUBSURFACE CONDITIONS SHOWN HEREON APPLIES ONLY AT THE SPECIFIC BORING OR TRENCH LOCATION AND AT THE DATE INDICATED. IT IS NOT WARRANTED TO BE REPRESENTATIVE OF SUBSURFACE CONDITIONS AT OTHER LOCATIONS AND TIMES.

DEPTH IN FEET	SAMPLE NO.	LITHOLOGY	GROUNDWATER	SOIL CLASS (USCS)	TEST PIT TP 13		PENETRATION RESISTANCE (BLOWS/FT.)	DRY DENSITY (P.C.F.)	MOISTURE CONTENT (%)
					ELEV. (MSL.) <u>513'</u>	DATE COMPLETED <u>03-08-2019</u>			
					EQUIPMENT <u>Backhoe</u> BY: <u>R. ADAMS</u>				
MATERIAL DESCRIPTION									
0		[Hatched Pattern]		CH	TOPSOIL (Ts) Soft, moist to wet, brownish black, CLAY; trace rounded gravel				
2			CH	TERRACE DEPOSITS-Clay Member (Qtc) Firm to stiff, damp, grayish brown CLAY; trace sand; trace carbonate					
4			CL	Stiff to hard, dry to damp, yellowish brown to reddish brown, CLAY; blocky texture (peds) with manganese films along fractures					
6					-Crumbly block texture with abundant carbonate				
8					-Becomes hard with blocky texture				
10					-Very hard excavation				
					PRACTICAL REFUSAL AT 11 FEET Groundwater not encountered Backfilled 03-08-2019				

Figure A-13,
Log of Test Pit TP 13, Page 1 of 1

G2338-42-01 (BORING AND TEST PIT).GPJ

SAMPLE SYMBOLS	 ... SAMPLING UNSUCCESSFUL	 ... STANDARD PENETRATION TEST	 ... DRIVE SAMPLE (UNDISTURBED)
	 ... DISTURBED OR BAG SAMPLE	 ... CHUNK SAMPLE	 ... WATER TABLE OR SEEPAGE

NOTE: THE LOG OF SUBSURFACE CONDITIONS SHOWN HEREON APPLIES ONLY AT THE SPECIFIC BORING OR TRENCH LOCATION AND AT THE DATE INDICATED. IT IS NOT WARRANTED TO BE REPRESENTATIVE OF SUBSURFACE CONDITIONS AT OTHER LOCATIONS AND TIMES.









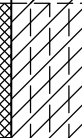
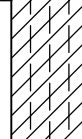

DEPTH IN FEET	SAMPLE NO.	LITHOLOGY	GROUNDWATER	SOIL CLASS (USCS)	TEST PIT TP 14		PENETRATION RESISTANCE (BLOWS/FT.)	DRY DENSITY (P.C.F.)	MOISTURE CONTENT (%)
					ELEV. (MSL.) <u>508'</u>	DATE COMPLETED <u>03-08-2019</u>			
					EQUIPMENT <u>Backhoe</u> BY: <u>R. ADAMS</u>				
MATERIAL DESCRIPTION									
0				CH	TOPSOIL (Ts) Soft, moist, dark brown, CLAY; trace carbonate				
2				CH	TERRACE DEPOSITS-Clay Member (Qtc) Firm to stiff, damp, brownish gray to black, CLAY; trace sand				
4	TP14-1			CL/SC	Stiff, damp, yellowish brown to orange brown, Silty CLAY and Clayey SAND mixture				
6									
8									
10				SC	TERRACE DEPOSITS-Sand/Gravel Member (Qtg) Dense, damp, yellowish brown, Clayey SAND; trace cobble				
					TRENCH TERMINATED AT 11 FEET Groundwater not encountered Backfilled 03-08-2019				

Figure A-14,
Log of Test Pit TP 14, Page 1 of 1

G2338-42-01 (BORING AND TEST PIT).GPJ

SAMPLE SYMBOLS		... SAMPLING UNSUCCESSFUL		... STANDARD PENETRATION TEST		... DRIVE SAMPLE (UNDISTURBED)
		... DISTURBED OR BAG SAMPLE		... CHUNK SAMPLE		... WATER TABLE OR SEEPAGE

NOTE: THE LOG OF SUBSURFACE CONDITIONS SHOWN HEREON APPLIES ONLY AT THE SPECIFIC BORING OR TRENCH LOCATION AND AT THE DATE INDICATED. IT IS NOT WARRANTED TO BE REPRESENTATIVE OF SUBSURFACE CONDITIONS AT OTHER LOCATIONS AND TIMES.









DEPTH IN FEET	SAMPLE NO.	LITHOLOGY	GROUNDWATER	SOIL CLASS (USCS)	TEST PIT TP 15		PENETRATION RESISTANCE (BLOWS/FT.)	DRY DENSITY (P.C.F.)	MOISTURE CONTENT (%)
					ELEV. (MSL.) <u>509'</u>	DATE COMPLETED <u>03-08-2019</u>			
					EQUIPMENT <u>Backhoe</u> BY: <u>R. ADAMS</u>				
MATERIAL DESCRIPTION									
0				CH	TOPSOIL (Ts) Soft, moist, dark brownish black CLAY				
2				CH	TERRACE DEPOSITS-Clay Member (Qtc) Stiff, damp, grayish brown, Sandy CLAY; trace gravel; trace carbonate				
4				SC	TERRACE DEPOSITS-Sand/Gravel Member (Qtg) Dense, damp, pale yellowish brown to grayish brown, Clayey, fine to coarse SAND; trace gravel				
6					TRENCH TERMINATED AT 6 FEET Groundwater not encountered Backfilled 03-08-2019				
8									
10									
12									
14									
16									

Figure A-15,
Log of Test Pit TP 15, Page 1 of 1

G2338-42-01 (BORING AND TEST PIT).GPJ

SAMPLE SYMBOLS		... SAMPLING UNSUCCESSFUL		... STANDARD PENETRATION TEST		... DRIVE SAMPLE (UNDISTURBED)
		... DISTURBED OR BAG SAMPLE		... CHUNK SAMPLE		... WATER TABLE OR SEEPAGE

NOTE: THE LOG OF SUBSURFACE CONDITIONS SHOWN HEREON APPLIES ONLY AT THE SPECIFIC BORING OR TRENCH LOCATION AND AT THE DATE INDICATED. IT IS NOT WARRANTED TO BE REPRESENTATIVE OF SUBSURFACE CONDITIONS AT OTHER LOCATIONS AND TIMES.









DEPTH IN FEET	SAMPLE NO.	LITHOLOGY	GROUNDWATER	SOIL CLASS (USCS)	TEST PIT TP 16		PENETRATION RESISTANCE (BLOWS/FT.)	DRY DENSITY (P.C.F.)	MOISTURE CONTENT (%)
					ELEV. (MSL.) <u>507'</u>	DATE COMPLETED <u>03-08-2019</u>			
					EQUIPMENT <u>Backhoe</u> BY: <u>R. ADAMS</u>				
MATERIAL DESCRIPTION									
0	TP16-1			CH	TOPSOIL (Ts) Soft, moist to wet, brownish black, CLAY				
2				CH	TERRACE DEPOSITS-Clay Member (Qtc) Stiff, damp to moist, whitish gray, Sandy CLAY; trace silt				
4				SM	TERRACE DEPOSITS-Sand/Gravel Member (Qtg) Dense, damp, Silty, medium to coarse SAND; trace clay; trace cobble up to 6-inch diameter				
6					TRENCH TERMINATED AT 7 FEET Groundwater not encountered Backfilled 03-08-2019				

Figure A-16,
Log of Test Pit TP 16, Page 1 of 1

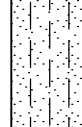
G2338-42-01 (BORING AND TEST PIT).GPJ

SAMPLE SYMBOLS		... SAMPLING UNSUCCESSFUL		... STANDARD PENETRATION TEST		... DRIVE SAMPLE (UNDISTURBED)
		... DISTURBED OR BAG SAMPLE		... CHUNK SAMPLE		... WATER TABLE OR SEEPAGE

NOTE: THE LOG OF SUBSURFACE CONDITIONS SHOWN HEREON APPLIES ONLY AT THE SPECIFIC BORING OR TRENCH LOCATION AND AT THE DATE INDICATED. IT IS NOT WARRANTED TO BE REPRESENTATIVE OF SUBSURFACE CONDITIONS AT OTHER LOCATIONS AND TIMES.

APPENDIX

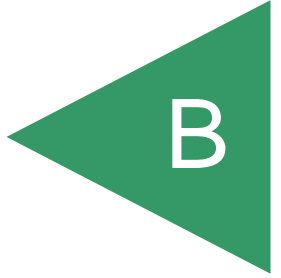

APPENDIX B

LABORATORY TESTING

We performed laboratory tests in accordance with generally accepted test methods of the American Society for Testing and Materials (ASTM) or other suggested procedures. We tested selected samples for maximum dry density and optimum moisture content, direct shear, expansion, plasticity, water-soluble sulfate, chloride ion content, and gradation characteristics. The results of our laboratory tests are presented in the following tables and figure.

SUMMARY OF LABORATORY MAXIMUM DRY DENSITY AND OPTIMUM MOISTURE CONTENT TEST RESULTS ASTM D 1557

Sample No.	Description	Maximum Dry Density (pcf)	Optimum Moisture Content (%)
TP 1-1	Dark brown, Sandy CLAY; trace gravel (CL)	127.6	9.7
TP 1-2	Brown, Clayey, fine to coarse SAND; trace gravel (SC)	126.7	10.6
TP 5-3	Brown, Silty, fine to coarse SAND; trace gravel (SM)	126.7	10.4
TP 10-1	Brown, Silty, fine to coarse SAND; trace gravel (SM)	130.4	8.4

SUMMARY OF LABORATORY DIRECT SHEAR TEST RESULTS ASTM D 3080

Sample No.	Dry Density (pcf)	Moisture Content (%)		Cohesion (psf)	Angle of Shear Resistance (degrees)
		Initial	Final		
TP 1-2*	115.0	10.2	15.3	330	36
TP 10-1*	117.4	8.6	13.2	0	40

*Sample remolded to approximately 90 percent of the maximum dry density near optimum moisture content.

SUMMARY OF LABORATORY EXPANSION INDEX TEST RESULTS ASTM D 4829

Sample No.	Moisture Content (%)		Dry Density (pcf)	Expansion Index	2022 CBC Expansion Classification	ASTM Soil Expansion Classification
	Before Test	After Test				
TP 1-1	9.7	18.1	111.2	29	Expansive	Low
TP 1-2	8.8	15.8	113.1	11	Non-Expansive	Very Low
TP 3-1	14.3	38.9	93.9	147	Expansive	Very High
TP 10-1	7.8	15.3	118.5	0	Non-Expansive	Very Low

**SUMMARY OF LABORATORY PLASTICITY INDEX TEST RESULTS
ASTM D 4318**

Sample No.	Depth (feet)	Geologic Unit	Liquid Limit	Plastic Limit	Plasticity Index
TP 1-1	1	Topsoil	42	16	26
TP 5-2	2 to 4	Qtc	66	18	48

**SUMMARY OF LABORATORY WATER-SOLUBLE SULFATE TEST RESULTS
CALIFORNIA TEST NO. 417**

Sample No.	Water-Soluble Sulfate (%)	Sulfate Class
TP 5-3	0.014	S0

**SUMMARY OF LABORATORY CHLORIDE ION CONTENT TEST RESULTS
CALIFORNIA TEST NO. 422**

Sample No.	Chloride Ion Content (%)	Chloride Ion Content (ppm)
TP 5-3	0.011	111

GRAVEL		SAND			SILT OR CLAY
COARSE	FINE	COARSE	MEDIUM	FINE	

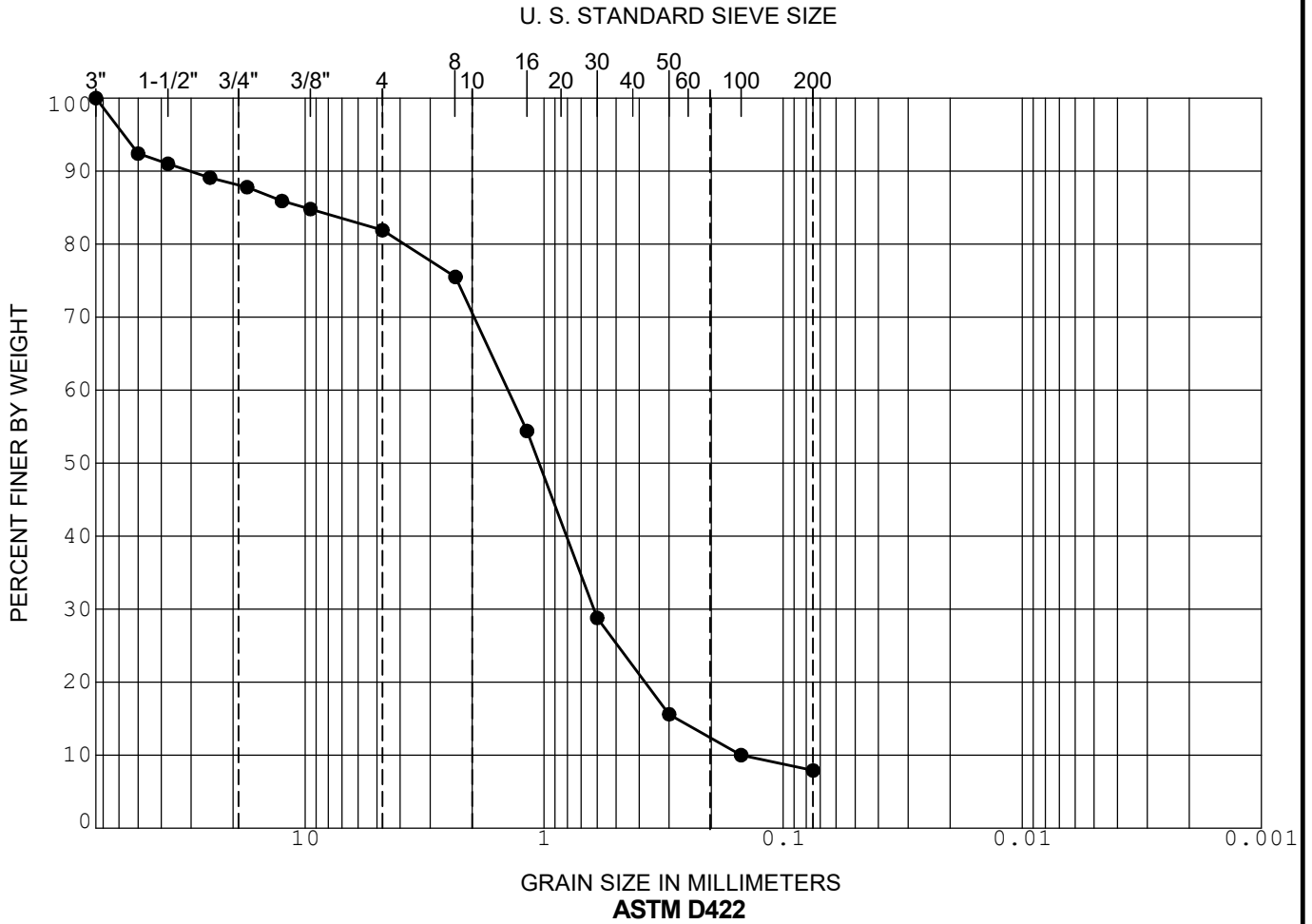

	SAMPLE	DEPTH (ft)	CLASSIFICATION	NAT WC	LL	PL	PI
●	TP10-1	1.0	(SW-SM) Well graded SAND with silt and gravel				
☒							
▲							

GRADATION CURVE

OTAY CENTRAL VILLAGE
 PLANNING AREAS 10-13 AND 17, AIRWAY ROAD AND CACTUS ROAD
 SAN DIEGO, CALIFORNIA

APPENDIX

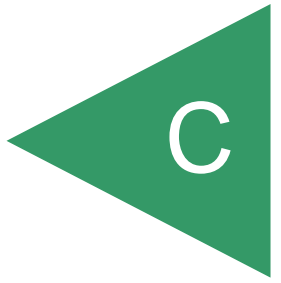

APPENDIX C

RECOMMENDED GRADING SPECIFICATIONS

FOR

**THE COLLECTION AT CACTUS
NORTHEAST CORNER OF
AIRWAY ROAD AND CACTUS ROAD
SAN DIEGO, CALIFORNIA**

PROJECT NO. G2338-42-02

RECOMMENDED GRADING SPECIFICATIONS

1. GENERAL

- 1.1 These Recommended Grading Specifications shall be used in conjunction with the Geotechnical Report for the project prepared by Geocon. The recommendations contained in the text of the Geotechnical Report are a part of the earthwork and grading specifications and shall supersede the provisions contained hereinafter in the case of conflict.
- 1.2 Prior to the commencement of grading, a geotechnical consultant (Consultant) shall be employed for the purpose of observing earthwork procedures and testing the fills for substantial conformance with the recommendations of the Geotechnical Report and these specifications. The Consultant should provide adequate testing and observation services so that they may assess whether, in their opinion, the work was performed in substantial conformance with these specifications. It shall be the responsibility of the Contractor to assist the Consultant and keep them apprised of work schedules and changes so that personnel may be scheduled accordingly.
- 1.3 It shall be the sole responsibility of the Contractor to provide adequate equipment and methods to accomplish the work in accordance with applicable grading codes or agency ordinances, these specifications and the approved grading plans. If, in the opinion of the Consultant, unsatisfactory conditions such as questionable soil materials, poor moisture condition, inadequate compaction, and/or adverse weather result in a quality of work not in conformance with these specifications, the Consultant will be empowered to reject the work and recommend to the Owner that grading be stopped until the unacceptable conditions are corrected.

2. DEFINITIONS

- 2.1 **Owner** shall refer to the owner of the property or the entity on whose behalf the grading work is being performed and who has contracted with the Contractor to have grading performed.
- 2.2 **Contractor** shall refer to the Contractor performing the site grading work.
- 2.3 **Civil Engineer** or **Engineer of Work** shall refer to the California licensed Civil Engineer or consulting firm responsible for preparation of the grading plans, surveying and verifying as-graded topography.
- 2.4 **Consultant** shall refer to the soil engineering and engineering geology consulting firm retained to provide geotechnical services for the project.

- 2.5 **Soil Engineer** shall refer to a California licensed Civil Engineer retained by the Owner, who is experienced in the practice of geotechnical engineering. The Soil Engineer shall be responsible for having qualified representatives on-site to observe and test the Contractor's work for conformance with these specifications.
- 2.6 **Engineering Geologist** shall refer to a California licensed Engineering Geologist retained by the Owner to provide geologic observations and recommendations during the site grading.
- 2.7 **Geotechnical Report** shall refer to a soil report (including all addenda) which may include a geologic reconnaissance or geologic investigation that was prepared specifically for the development of the project for which these Recommended Grading Specifications are intended to apply.

3. MATERIALS

- 3.1 Materials for compacted fill shall consist of any soil excavated from the cut areas or imported to the site that, in the opinion of the Consultant, is suitable for use in construction of fills. In general, fill materials can be classified as *soil* fills, *soil-rock* fills or *rock* fills, as defined below.
- 3.1.1 **Soil fills** are defined as fills containing no rocks or hard lumps greater than 12 inches in maximum dimension and containing at least 40 percent by weight of material smaller than $\frac{3}{4}$ inch in size.
- 3.1.2 **Soil-rock fills** are defined as fills containing no rocks or hard lumps larger than 4 feet in maximum dimension and containing a sufficient matrix of soil fill to allow for proper compaction of soil fill around the rock fragments or hard lumps as specified in Paragraph 6.2. **Oversize rock** is defined as material greater than 12 inches.
- 3.1.3 **Rock fills** are defined as fills containing no rocks or hard lumps larger than 3 feet in maximum dimension and containing little or no fines. Fines are defined as material smaller than $\frac{3}{4}$ inch in maximum dimension. The quantity of fines shall be less than approximately 20 percent of the rock fill quantity.
- 3.2 Material of a perishable, spongy, or otherwise unsuitable nature as determined by the Consultant shall not be used in fills.
- 3.3 Materials used for fill, either imported or on-site, shall not contain hazardous materials as defined by the California Code of Regulations, Title 22, Division 4, Chapter 30, Articles 9

and 10; 40CFR; and any other applicable local, state or federal laws. The Consultant shall not be responsible for the identification or analysis of the potential presence of hazardous materials. However, if observations, odors or soil discoloration cause Consultant to suspect the presence of hazardous materials, the Consultant may request from the Owner the termination of grading operations within the affected area. Prior to resuming grading operations, the Owner shall provide a written report to the Consultant indicating that the suspected materials are not hazardous as defined by applicable laws and regulations.

- 3.4 The outer 15 feet of *soil-rock* fill slopes, measured horizontally, should be composed of properly compacted *soil* fill materials approved by the Consultant. *Rock* fill may extend to the slope face, provided that the slope is not steeper than 2:1 (horizontal:vertical) and a soil layer no thicker than 12 inches is track-walked onto the face for landscaping purposes. This procedure may be utilized provided it is acceptable to the governing agency, Owner and Consultant.
- 3.5 Samples of soil materials to be used for fill should be tested in the laboratory by the Consultant to determine the maximum density, optimum moisture content, and, where appropriate, shear strength, expansion, and gradation characteristics of the soil.
- 3.6 During grading, soil or groundwater conditions other than those identified in the Geotechnical Report may be encountered by the Contractor. The Consultant shall be notified immediately to evaluate the significance of the unanticipated condition.

4. CLEARING AND PREPARING AREAS TO BE FILLED

- 4.1 Areas to be excavated and filled shall be cleared and grubbed. Clearing shall consist of complete removal above the ground surface of trees, stumps, brush, vegetation, man-made structures, and similar debris. Grubbing shall consist of removal of stumps, roots, buried logs and other unsuitable material and shall be performed in areas to be graded. Roots and other projections exceeding 1½ inches in diameter shall be removed to a depth of 3 feet below the surface of the ground. Borrow areas shall be grubbed to the extent necessary to provide suitable fill materials.
- 4.2 Asphalt pavement material removed during clearing operations should be properly disposed at an approved off-site facility or in an acceptable area of the project evaluated by Geocon and the property owner. Concrete fragments that are free of reinforcing steel may be placed in fills, provided they are placed in accordance with Section 6.2 or 6.3 of this document.

- 4.3 After clearing and grubbing of organic matter and other unsuitable material, loose or porous soils shall be removed to the depth recommended in the Geotechnical Report. The depth of removal and compaction should be observed and approved by a representative of the Consultant. The exposed surface shall then be plowed or scarified to a minimum depth of 6 inches and until the surface is free from uneven features that would tend to prevent uniform compaction by the equipment to be used.
- 4.4 Where the slope ratio of the original ground is steeper than 5:1 (horizontal:vertical), or where recommended by the Consultant, the original ground should be benched in accordance with the following illustration.

TYPICAL BENCHING DETAIL

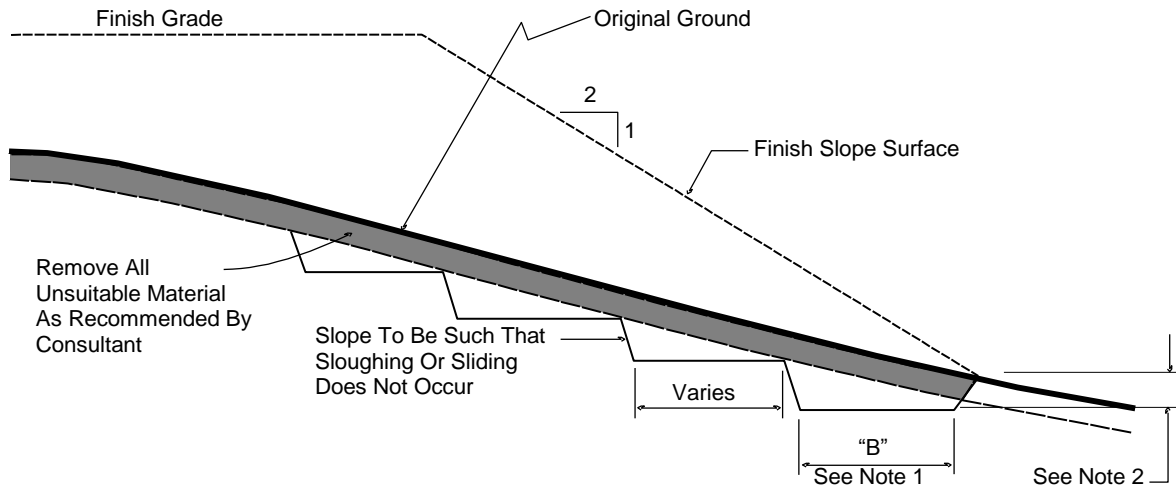

No Scale

- DETAIL NOTES:
- (1) Key width "B" should be a minimum of 10 feet, or sufficiently wide to permit complete coverage with the compaction equipment used. The base of the key should be graded horizontal, or inclined slightly into the natural slope.
 - (2) The outside of the key should be below the topsoil or unsuitable surficial material and at least 2 feet into dense formational material. Where hard rock is exposed in the bottom of the key, the depth and configuration of the key may be modified as approved by the Consultant.

- 4.5 After areas to receive fill have been cleared and scarified, the surface should be moisture conditioned to achieve the proper moisture content, and compacted as recommended in Section 6 of these specifications.

5. COMPACTION EQUIPMENT

- 5.1 Compaction of *soil* or *soil-rock* fill shall be accomplished by sheepsfoot or segmented-steel wheeled rollers, vibratory rollers, multiple-wheel pneumatic-tired rollers, or other types of acceptable compaction equipment. Equipment shall be of such a design that it will be capable of compacting the *soil* or *soil-rock* fill to the specified relative compaction at the specified moisture content.
- 5.2 Compaction of *rock* fills shall be performed in accordance with Section 6.3.

6. PLACING, SPREADING AND COMPACTION OF FILL MATERIAL

- 6.1 *Soil* fill, as defined in Paragraph 3.1.1, shall be placed by the Contractor in accordance with the following recommendations:
- 6.1.1 *Soil* fill shall be placed by the Contractor in layers that, when compacted, should generally not exceed 8 inches. Each layer shall be spread evenly and shall be thoroughly mixed during spreading to obtain uniformity of material and moisture in each layer. The entire fill shall be constructed as a unit in nearly level lifts. Rock materials greater than 12 inches in maximum dimension shall be placed in accordance with Section 6.2 or 6.3 of these specifications.
- 6.1.2 In general, the *soil* fill shall be compacted at a moisture content at or above the optimum moisture content as determined by ASTM D 1557.
- 6.1.3 When the moisture content of *soil* fill is below that specified by the Consultant, water shall be added by the Contractor until the moisture content is in the range specified.
- 6.1.4 When the moisture content of the *soil* fill is above the range specified by the Consultant or too wet to achieve proper compaction, the *soil* fill shall be aerated by the Contractor by blading/mixing, or other satisfactory methods until the moisture content is within the range specified.
- 6.1.5 After each layer has been placed, mixed, and spread evenly, it shall be thoroughly compacted by the Contractor to a relative compaction of at least 90 percent. Relative compaction is defined as the ratio (expressed in percent) of the in-place dry density of the compacted fill to the maximum laboratory dry density as determined in accordance with ASTM D 1557. Compaction shall be continuous over the entire area, and compaction equipment shall make sufficient passes so that the specified minimum relative compaction has been achieved throughout the entire fill.

- 6.1.6 Where practical, soils having an Expansion Index greater than 50 should be placed at least 3 feet below finish pad grade and should be compacted at a moisture content generally 2 to 4 percent greater than the optimum moisture content for the material.
 - 6.1.7 Properly compacted *soil* fill shall extend to the design surface of fill slopes. To achieve proper compaction, it is recommended that fill slopes be over-built by at least 3 feet and then cut to the design grade. This procedure is considered preferable to track-walking of slopes, as described in the following paragraph.
 - 6.1.8 As an alternative to over-building of slopes, slope faces may be back-rolled with a heavy-duty loaded sheepsfoot or vibratory roller at maximum 4-foot fill height intervals. Upon completion, slopes should then be track-walked with a D-8 dozer or similar equipment, such that a dozer track covers all slope surfaces at least twice.
- 6.2 *Soil-rock* fill, as defined in Paragraph 3.1.2, shall be placed by the Contractor in accordance with the following recommendations:
- 6.2.1 Rocks larger than 12 inches but less than 4 feet in maximum dimension may be incorporated into the compacted *soil* fill, but shall be limited to the area measured 15 feet minimum horizontally from the slope face and 5 feet below finish grade or 3 feet below the deepest utility, whichever is deeper.
 - 6.2.2 Rocks or rock fragments up to 4 feet in maximum dimension may either be individually placed or placed in windrows. Under certain conditions, rocks or rock fragments up to 10 feet in maximum dimension may be placed using similar methods. The acceptability of placing rock materials greater than 4 feet in maximum dimension shall be evaluated during grading as specific cases arise and shall be approved by the Consultant prior to placement.
 - 6.2.3 For individual placement, sufficient space shall be provided between rocks to allow for passage of compaction equipment.
 - 6.2.4 For windrow placement, the rocks should be placed in trenches excavated in properly compacted *soil* fill. Trenches should be approximately 5 feet wide and 4 feet deep in maximum dimension. The voids around and beneath rocks should be filled with approved granular soil having a Sand Equivalent of 30 or greater and should be compacted by flooding. Windrows may also be placed utilizing an "open-face" method in lieu of the trench procedure, however, this method should first be approved by the Consultant.

- 6.2.5 Windrows should generally be parallel to each other and may be placed either parallel to or perpendicular to the face of the slope depending on the site geometry. The minimum horizontal spacing for windrows shall be 12 feet center-to-center with a 5-foot stagger or offset from lower courses to next overlying course. The minimum vertical spacing between windrow courses shall be 2 feet from the top of a lower windrow to the bottom of the next higher windrow.
- 6.2.6 Rock placement, fill placement and flooding of approved granular soil in the windrows should be continuously observed by the Consultant.
- 6.3 *Rock* fills, as defined in Section 3.1.3, shall be placed by the Contractor in accordance with the following recommendations:
- 6.3.1 The base of the *rock* fill shall be placed on a sloping surface (minimum slope of 2 percent). The surface shall slope toward suitable subdrainage outlet facilities. The *rock* fills shall be provided with subdrains during construction so that a hydrostatic pressure buildup does not develop. The subdrains shall be permanently connected to controlled drainage facilities to control post-construction infiltration of water.
- 6.3.2 *Rock* fills shall be placed in lifts not exceeding 3 feet. Placement shall be by rock trucks traversing previously placed lifts and dumping at the edge of the currently placed lift. Spreading of the *rock* fill shall be by dozer to facilitate *seating* of the rock. The *rock* fill shall be watered heavily during placement. Watering shall consist of water trucks traversing in front of the current rock lift face and spraying water continuously during rock placement. Compaction equipment with compactive energy comparable to or greater than that of a 20-ton steel vibratory roller or other compaction equipment providing suitable energy to achieve the required compaction or deflection as recommended in Paragraph 6.3.3 shall be utilized. The number of passes to be made should be determined as described in Paragraph 6.3.3. Once a *rock* fill lift has been covered with *soil* fill, no additional *rock* fill lifts will be permitted over the *soil* fill.
- 6.3.3 Plate bearing tests, in accordance with ASTM D 1196, may be performed in both the compacted *soil* fill and in the *rock* fill to aid in determining the required minimum number of passes of the compaction equipment. If performed, a minimum of three plate bearing tests should be performed in the properly compacted *soil* fill (minimum relative compaction of 90 percent). Plate bearing tests shall then be performed on areas of *rock* fill having two passes, four passes and six passes of the compaction equipment, respectively. The number of passes required for the *rock* fill shall be determined by comparing the results of the plate bearing tests for the *soil* fill and the *rock* fill and by evaluating the deflection

variation with number of passes. The required number of passes of the compaction equipment will be performed as necessary until the plate bearing deflections are equal to or less than that determined for the properly compacted *soil* fill. In no case will the required number of passes be less than two.

- 6.3.4 A representative of the Consultant should be present during *rock* fill operations to observe that the minimum number of “passes” have been obtained, that water is being properly applied and that specified procedures are being followed. The actual number of plate bearing tests will be determined by the Consultant during grading.
- 6.3.5 Test pits shall be excavated by the Contractor so that the Consultant can state that, in their opinion, sufficient water is present and that voids between large rocks are properly filled with smaller rock material. In-place density testing will not be required in the *rock* fills.
- 6.3.6 To reduce the potential for “piping” of fines into the *rock* fill from overlying *soil* fill material, a 2-foot layer of graded filter material shall be placed above the uppermost lift of *rock* fill. The need to place graded filter material below the *rock* should be determined by the Consultant prior to commencing grading. The gradation of the graded filter material will be determined at the time the *rock* fill is being excavated. Materials typical of the *rock* fill should be submitted to the Consultant in a timely manner, to allow design of the graded filter prior to the commencement of *rock* fill placement.
- 6.3.7 *Rock* fill placement should be continuously observed during placement by the Consultant.

7. SUBDRAINS

- 7.1 The geologic units on the site may have permeability characteristics and/or fracture systems that could be susceptible under certain conditions to seepage. The use of canyon subdrains may be necessary to mitigate the potential for adverse impacts associated with seepage conditions. Canyon subdrains with lengths in excess of 500 feet or extensions of existing offsite subdrains should use 8-inch-diameter pipes. Canyon subdrains less than 500 feet in length should use 6-inch-diameter pipes.

TYPICAL CANYON DRAIN DETAIL

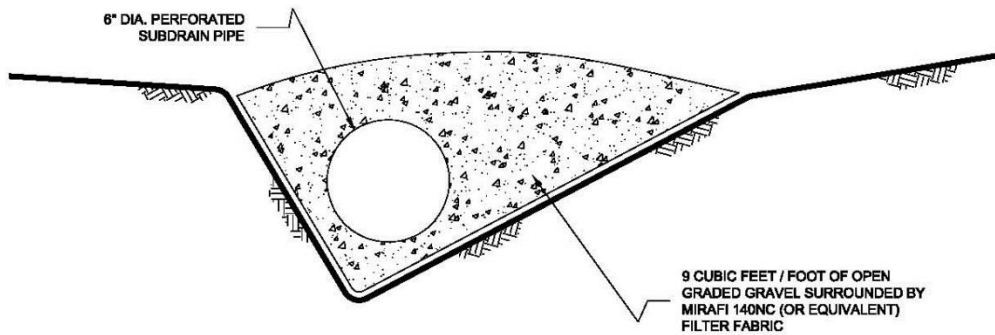
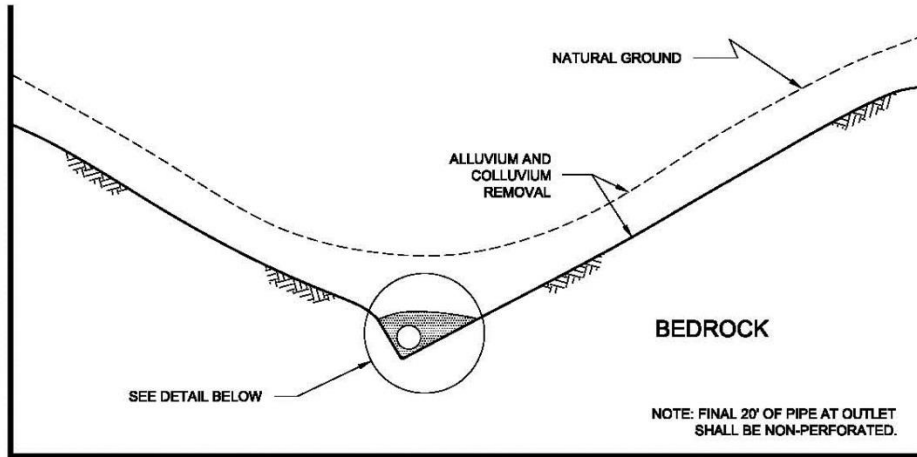

NOTES:

- 1.....8-INCH DIAMETER, SCHEDULE 80 PVC PERFORATED PIPE FOR FILLS IN EXCESS OF 100-FEET IN DEPTH OR A PIPE LENGTH OF LONGER THAN 500 FEET.
- 2.....6-INCH DIAMETER, SCHEDULE 40 PVC PERFORATED PIPE FOR FILLS LESS THAN 100-FEET IN DEPTH OR A PIPE LENGTH SHORTER THAN 500 FEET.

NO SCALE

7.2 Slope drains within stability fill keyways should use 4-inch-diameter (or larger) pipes.

TYPICAL STABILITY FILL DETAIL

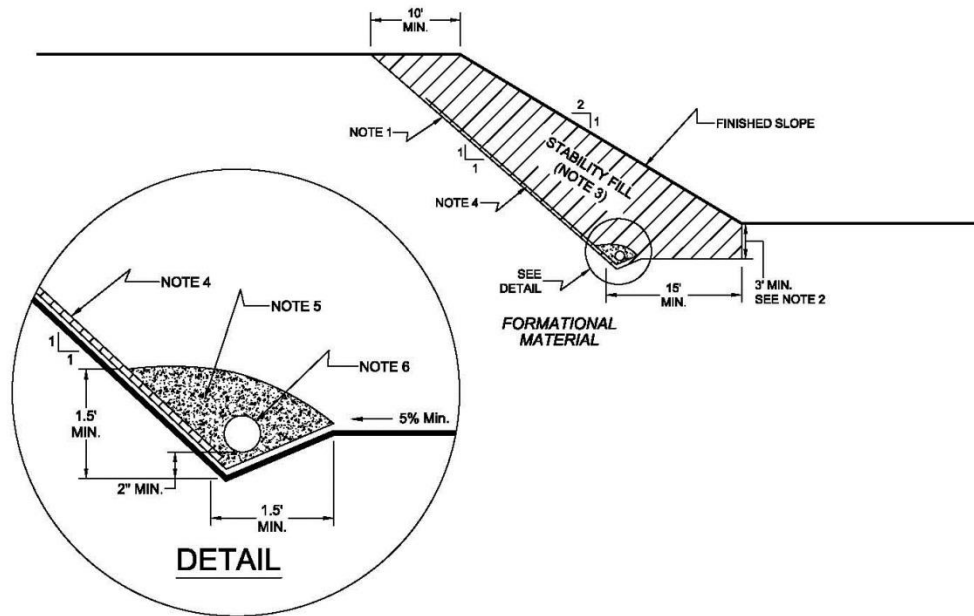

NOTES:

- 1.....EXCAVATE BACKCUT AT 1:1 INCLINATION (UNLESS OTHERWISE NOTED).
- 2.....BASE OF STABILITY FILL TO BE 3 FEET INTO FORMATIONAL MATERIAL, SLOPING A MINIMUM 5% INTO SLOPE.
- 3.....STABILITY FILL TO BE COMPOSED OF PROPERLY COMPACTED GRANULAR SOIL.
- 4.....CHIMNEY DRAINS TO BE APPROVED PREFABRICATED CHIMNEY DRAIN PANELS (MIRADRAIN G200N OR EQUIVALENT) SPACED APPROXIMATELY 20 FEET CENTER TO CENTER AND 4 FEET WIDE. CLOSER SPACING MAY BE REQUIRED IF SEEPAGE IS ENCOUNTERED.
- 5.....FILTER MATERIAL TO BE 3/4-INCH, OPEN-GRADED CRUSHED ROCK ENCLOSED IN APPROVED FILTER FABRIC (MIRAFI 140NC).
- 6.....COLLECTOR PIPE TO BE 4-INCH MINIMUM DIAMETER, PERFORATED, THICK-WALLED PVC SCHEDULE 40 OR EQUIVALENT, AND SLOPED TO DRAIN AT 1 PERCENT MINIMUM TO APPROVED OUTLET.

NO SCALE

7.3 The actual subdrain locations will be evaluated in the field during the remedial grading operations. Additional drains may be necessary depending on the conditions observed and the requirements of the local regulatory agencies. Appropriate subdrain outlets should be evaluated prior to finalizing 40-scale grading plans.

7.4 *Rock fill or soil-rock fill* areas may require subdrains along their down-slope perimeters to mitigate the potential for buildup of water from construction or landscape irrigation. The subdrains should be at least 6-inch-diameter pipes encapsulated in gravel and filter fabric. *Rock fill* drains should be constructed using the same requirements as canyon subdrains.

7.5 Prior to outletting, the final 20-foot segment of a subdrain that will not be extended during future development should consist of non-perforated drainpipe. At the non-perforated/perforated interface, a seepage cutoff wall should be constructed on the downslope side of the pipe.

TYPICAL CUT OFF WALL DETAIL

FRONT VIEW

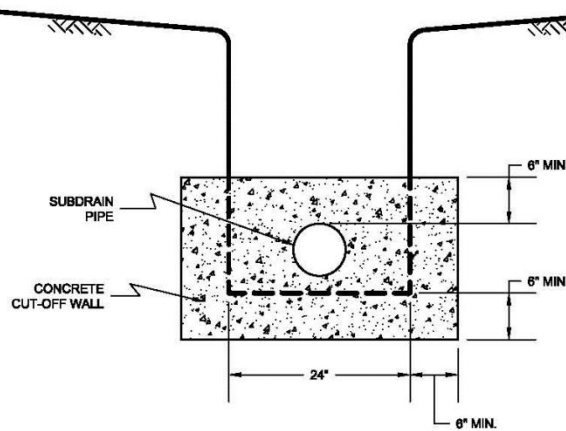

NO SCALE

SIDE VIEW

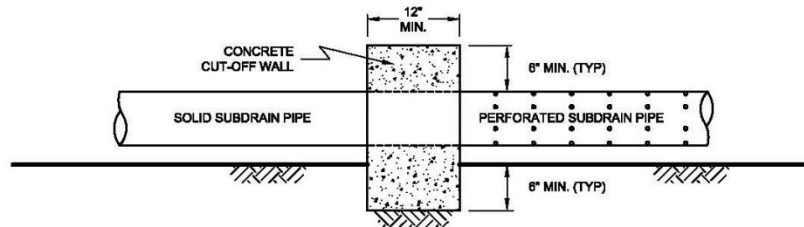

NO SCALE

7.6 Subdrains that discharge into a natural drainage course or open space area should be provided with a permanent headwall structure.

TYPICAL HEADWALL DETAIL

FRONT VIEW

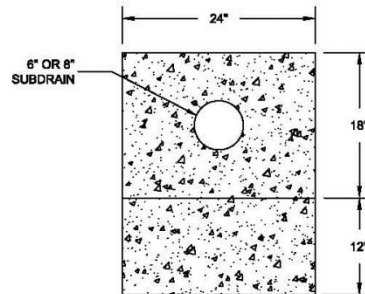

NO SCALE

SIDE VIEW

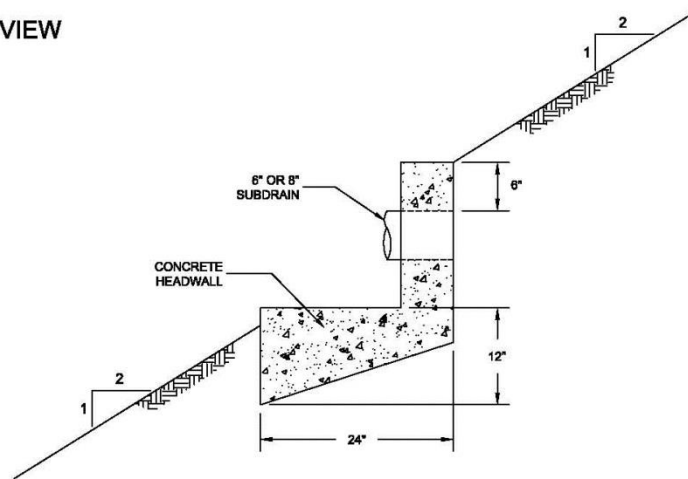

NOTE: HEADWALL SHOULD OUTLET AT TOE OF FILL SLOPE
OR INTO CONTROLLED SURFACE DRAINAGE

NO SCALE

- 7.7 The final grading plans should show the location of the proposed subdrains. After completion of remedial excavations and subdrain installation, the project civil engineer should survey the drain locations and prepare an “as-built” map showing the drain locations. The final outlet and connection locations should be determined during grading operations. Subdrains that will be extended on adjacent projects after grading can be placed on formational material and a vertical riser should be placed at the end of the subdrain. The grading contractor should consider videoing the subdrains shortly after burial to check proper installation and functionality. The contractor is responsible for the performance of the drains.

8. OBSERVATION AND TESTING

- 8.1 The Consultant shall be the Owner's representative to observe and perform tests during clearing, grubbing, filling, and compaction operations. In general, no more than 2 feet in vertical elevation of *soil* or *soil-rock* fill should be placed without at least one field density test being performed within that interval. In addition, a minimum of one field density test should be performed for every 2,000 cubic yards of *soil* or *soil-rock* fill placed and compacted.
- 8.2 The Consultant should perform a sufficient distribution of field density tests of the compacted *soil* or *soil-rock* fill to provide a basis for expressing an opinion whether the fill material is compacted as specified. Density tests shall be performed in the compacted materials below any disturbed surface. When these tests indicate that the density of any layer of fill or portion thereof is below that specified, the particular layer or areas represented by the test shall be reworked until the specified density has been achieved.
- 8.3 During placement of *rock* fill, the Consultant should observe that the minimum number of passes have been obtained per the criteria discussed in Section 6.3.3. The Consultant should request the excavation of observation pits and may perform plate bearing tests on the placed *rock* fills. The observation pits will be excavated to provide a basis for expressing an opinion as to whether the *rock* fill is properly seated and sufficient moisture has been applied to the material. When observations indicate that a layer of *rock* fill or any portion thereof is below that specified, the affected layer or area shall be reworked until the *rock* fill has been adequately seated and sufficient moisture applied.
- 8.4 A settlement monitoring program designed by the Consultant may be conducted in areas of *rock* fill placement. The specific design of the monitoring program shall be as recommended in the Conclusions and Recommendations section of the project Geotechnical Report or in the final report of testing and observation services performed during grading.
- 8.5 We should observe the placement of subdrains, to check that the drainage devices have been placed and constructed in substantial conformance with project specifications.
- 8.6 Testing procedures shall conform to the following Standards as appropriate:

8.6.1 Soil and Soil-Rock Fills:

- 8.6.1.1 Field Density Test, ASTM D 1556, *Density of Soil In-Place By the Sand-Cone Method.*

- 8.6.1.2 Field Density Test, Nuclear Method, ASTM D 6938, *Density of Soil and Soil-Aggregate In-Place by Nuclear Methods (Shallow Depth)*.
- 8.6.1.3 Laboratory Compaction Test, ASTM D 1557, *Moisture-Density Relations of Soils and Soil-Aggregate Mixtures Using 10-Pound Hammer and 18-Inch Drop*.
- 8.6.1.4 Expansion Index Test, ASTM D 4829, *Expansion Index Test*.

9. PROTECTION OF WORK

- 9.1 During construction, the Contractor shall properly grade all excavated surfaces to provide positive drainage and prevent ponding of water. Drainage of surface water shall be controlled to avoid damage to adjoining properties or to finished work on the site. The Contractor shall take remedial measures to prevent erosion of freshly graded areas until such time as permanent drainage and erosion control features have been installed. Areas subjected to erosion or sedimentation shall be properly prepared in accordance with the Specifications prior to placing additional fill or structures.
- 9.2 After completion of grading as observed and tested by the Consultant, no further excavation or filling shall be conducted except in conjunction with the services of the Consultant.

10. CERTIFICATIONS AND FINAL REPORTS

- 10.1 Upon completion of the work, Contractor shall furnish Owner a certification by the Civil Engineer stating that the lots and/or building pads are graded to within 0.1 foot vertically of elevations shown on the grading plan and that all tops and toes of slopes are within 0.5 foot horizontally of the positions shown on the grading plans. After installation of a section of subdrain, the project Civil Engineer should survey its location and prepare an *as-built* plan of the subdrain location. The project Civil Engineer should verify the proper outlet for the subdrains and the Contractor should ensure that the drain system is free of obstructions.
- 10.2 The Owner is responsible for furnishing a final as-graded soil and geologic report satisfactory to the appropriate governing or accepting agencies. The as-graded report should be prepared and signed by a California licensed Civil Engineer experienced in geotechnical engineering and by a California Certified Engineering Geologist, indicating that the geotechnical aspects of the grading were performed in substantial conformance with the Specifications or approved changes to the Specifications.

LIST OF REFERENCES

- CGS (2021a), *EQ Zapp: California Earthquake Hazards Zone Application*, web application that queries California Geological Survey mapped earthquake hazard zones, <https://www.conservation.ca.gov/cgs/geohazards/eq-zapp>, accessed April, 2023.
- CGS (2021b), *California Tsunami Maps and Data*, web application for accessing tsunami inundation hazard, <https://www.conservation.ca.gov/cgs/tsunami/maps>, accessed April, 2023.
- City of San Diego (2008), *Seismic Safety Study, Geologic Hazards and Faults, Map Sheet 7*.
- FEMA (2020), *Flood Insurance Rate Map (FIRM), Map Numbers 06073C2178G and 06073C2200G, Effective May 16, 2012*, <http://www.fema.gov/portal/home>, accessed April, 2023.
- Geocon Incorporated, *Geotechnical Investigation, Otay Central Village, Planning Areas 10 – 13 and 17, Airway Road and Cactus Road, San Diego California*, dated April 8, 2019 (Project No. G2338-42-01).
- Kennedy, M. P., and Tan, S. S., (2008), *Geologic Map of the San Diego 30' x 60' Quadrangle, California*, USGS Regional Geologic Map Series, 1:100,000 Scale, Map No. 3.
- Kennedy, M. P., and Tan, S. S., (2002), *Geologic Map of Otay Mesa 7.5' Quadrangle, San Diego County, California: A Digital Database*, USGS Regional Geologic Map Series, 1:24,000 Scale.
- SEAOC (2020), *OSHPD Seismic Design Maps*: Structural Engineers Association of California website, <http://seismicmaps.org/>, accessed March, 2023.
- USGS (2019), *Quaternary Fault and Fold Database of the United States*: U.S. Geological Survey website, <https://www.usgs.gov/programs/earthquake-hazards/faults>, accessed March, 2023.