

# City of San Diego

**CONTRACTOR'S NAME:** Palm Engineering Construction Co., Inc.  
**ADDRESS:** 7330 Opportunity Rd., Suite A&B, San Diego CA 92111  
**TELEPHONE NO.:** 619-291-1495 **FAX NO.:**  
**CITY CONTACT:** Rosa Riego, Senior Contract Specialist, Email: [RRiego@sandiego.gov](mailto:RRiego@sandiego.gov)  
Phone No. (619) 533-3426  
N. Mansury / A. Jaro / Y. Kawai

## BIDDING DOCUMENTS



**FOR**

## TORREY PINES PROSPECT-COAST WALK GUARDRAIL

BID NO.: **K-26-2448-DBB-3**  
SAP NO. (WBS/IO/CC): **B-19056**  
CLIENT DEPARTMENT: **2116**  
COUNCIL DISTRICT: **1**  
PROJECT TYPE: **IE**  
STATE AID PROJECT NO.: **HSIPSL-5004(213)**

**THIS CONTRACT WILL BE SUBJECT TO THE FOLLOWING:**

- PREVAILING WAGE RATES: STATE  FEDERAL
- APPRENTICESHIP
- THIS PROJECT IS FUNDED IN PART BY THE STATE OF CALIFORNIA, DEPARTMENT OF TRANSPORTATION-CALTRANS, STATE AID ID: HSIPSL-5004(213)

**BID DUE DATE:**

**2:00 PM  
MARCH 5, 2026**

**CITY OF SAN DIEGO'S ELECTRONIC BIDDING SITE, PLANETBIDS**

<http://www.sandiego.gov/cip/bidopps/>

**ENGINEER OF WORK**

The engineering Specifications and Special Provisions contained herein have been prepared by or under the direction of the following Registered Engineer:



1) Registered Engineer

12/16/25

Date

Seal:



2) City Engineer

12/15/2025

Date

Seal:



## TABLE OF CONTENTS

SECTION	PAGE
1. REQUIRED DOCUMENTS SCHEDULE.....	4
2. NOTICE INVITING BIDS.....	5
3. INSTRUCTIONS TO BIDDERS .....	8
4. PERFORMANCE AND PAYMENT BONDS .....	18
5. ATTACHMENTS:	
A. SCOPE OF WORK.....	21
B. RESERVED.....	23
C. EQUAL OPPORTUNITY CONTRACTING PROGRAM .....	24
D. PREVAILING WAGE.....	35
E. SUPPLEMENTARY SPECIAL PROVISIONS.....	40
1. Appendix A - Notice of Exemption .....	76
2. Appendix B - Fire Hydrant Meter Program .....	79
3. Appendix C - Materials Typically Accepted by Certificate of Compliance.....	93
4. Appendix D - Sample City Invoice.....	95
5. Appendix E - Location Map .....	97
6. Appendix F - Pavement Coring .....	99
7. Appendix G - Sample of Public Notice .....	101
8. Appendix H - Advanced Metering Infrastructure (AMI) Device Protection .....	103
9. Appendix I - Sample Contractor Performance Evaluation (CPE) Form .....	110
F. IN-USE OFF-ROAD DIESEL FUELED FLEET REGULATION (OFF-ROAD REGULATION) COMPLIANCE (CARB).....	120
G. CONTRACT AGREEMENT .....	124
6. CERTIFICATIONS AND FORMS.....	127

## REQUIRED DOCUMENTS SCHEDULE DURING BIDDING AND AWARDING

The Bidder's attention is directed to the City's Municipal Code §22.0807(d)(2) for important information regarding grounds for debarment for failure to submit required documentation.

The specified Equal Opportunity Contracting Program (EOCP) forms are available for download from the City's web site at:

<http://www.sandiego.gov/eoc/forms/>

ITEM	DOCUMENT TO BE SUBMITTED	WHEN DUE	FROM
1.	Bid Bond (PDF via PlanetBids)	At Time of Bid	ALL BIDDERS
2.	Contractor's Certification of Pending Actions	At Time of Bid	ALL BIDDERS
3.	Mandatory Disclosure of Business Interests	At Time of Bid	ALL BIDDERS
4.	Debarment and Suspension Certification for Prime Contractors	At Time of Bid	ALL BIDDERS
5.	Debarment and Suspension Certification for Subcontractors, Suppliers & Mfgs	At Time of Bid	ALL BIDDERS
6.	Bid Bond (Original)	By 5PM 1 working day after bid opening	ALL BIDDERS
7.	If the Contractor is a Joint Venture: <ul style="list-style-type: none"> <li>• Joint Venture Agreement</li> <li>• Joint Venture License</li> </ul>	Within 10 working days of receipt by bidder of contract forms	AWARDED BIDDER
8.	Payment & Performance Bond; Certificates of Insurance & Endorsements; and Signed Contract Agreement Page	Within 10 working days of receipt by bidder of contract forms and NOI	AWARDED BIDDER
9.	In-Use Off-Road Diesel Fueled Fleet Regulation (OFF-ROAD REGULATION) Compliance	Within 10 working days of receipt by bidder of contract forms and NOI	AWARDED BIDDER
10.	Listing of "Other Than First Tier" Subcontractors	Within 10 working days of receipt by bidder of contract forms	AWARDED BIDDER

## NOTICE INVITING BIDS

1. **SUMMARY OF WORK:** This is the City of San Diego's (City) solicitation process to acquire Construction services for **TORREY PINES PROSPECT-COAST WALK GUARDRAIL**. For additional information refer to Attachment A.
2. **FULL AND OPEN COMPETITION:** This solicitation is subject to full and open competition and may be bid by Contractors on the City's approved Prequalified Contractors List. For information regarding the Contractors Prequalified list visit the City's web site: <http://www.sandiego.gov>.
3. **ESTIMATED CONSTRUCTION COST:** The City's estimated construction cost for this project is **\$1,440,000.00**.
4. **BID DUE DATE AND TIME ARE: MARCH 5, 2026 at 2:00 PM.**
5. **PREVAILING WAGE RATES APPLY TO THIS CONTRACT:** Refer to Attachment D.
6. **LICENSE REQUIREMENT:** To be eligible for award of this contract, Prime contractor must possess the following licensing classification: **A**
7. **PRE-BID MEETING:**

**7.1. ONLINE PRE-BID MEETING:**

Prospective Bidders are **Required** to attend the Pre-Bid Meeting.

**Failure to attend the Pre-Bid Meeting will result in the Bidder's Bid being deemed non-responsive.**

**Bidders will not be admitted after the specified start time of the Meeting.**

The Pre-Bid Meeting will be held on **Wednesday, February 11, 2025 at 10:00 AM (PST)** at:

### **Microsoft Teams meeting**

**Join:** <https://teams.microsoft.com/meet/24442129613638?p=rBVtw30aCXWvi5C8QX>

**Meeting ID: 244 421 296 136 38**

**Passcode: xB2LH6Mx**

---

[Need help?](#) | [System reference](#)

Dial in by phone

[+1 945-468-5511,488452469#](tel:+19454685511488452469) United States, Dallas

[Find a local number](#)

Phone conference ID: 488 452 469#

For organizers: [Meeting options](#) | [Reset dial-in PIN](#)

**Please Note:** You will need to join the meeting with a computer, tablet or smartphone with the **Microsoft Teams** in order to sign in via the Chat feature as attendance at the

meeting will be evidenced by the Chat sign-in. The Chat feature will also be used for attendees to ask any questions.

The purpose of the meeting is to discuss the scope of the Project, submittal requirements, and any Equal Opportunity Contracting Program requirements and reporting procedures.

Upon entering the meeting, all attendees must use the chat feature to sign in with the following information: Name of firm, Attendee's name, Phone number and Email address.

**7.2. PRE-BID SITE VISIT:** All those wishing to submit a bid are encouraged to visit the Work Site with the Engineer. The purpose of the Site Visit is to acquaint Bidders with the Site conditions. To request a sign language or oral interpreter for this visit, call the Purchasing & Contracting Department, Public Works Division at (619) 533-3450 at least 5 Working Days prior to the meeting to ensure availability. The Pre-Bid Site Visit is scheduled as follows:

**Time: 10:30 AM**  
**Date: Tuesday, February 17, 2026**  
**Location: Torrey Pines Road and Prospect Place, San Diego, CA 92037**

**8. AWARD PROCESS:**

- 8.1.** The Award of this contract is contingent upon the Contractor's compliance with all conditions of Award as stated within these documents and within the Notice of Intent to Award.
- 8.2.** Upon acceptance of bids and determination of the apparent low bidder, the City will prepare the contract documents for execution within approximately 21 days of the date of the bid opening. The City will then award the contract upon receipt of properly signed Contract, bonds, and insurance documents.
- 8.3.** This contract will be deemed executed and effective only upon the signing of the Contract by the Mayor or his designee and approval as to form by the City Attorney's Office.
- 8.4.** The low Bid will be determined by the Base Bid.
- 8.5.** Once the low Bid has been determined, the City may, at its sole discretion, award the contract for the Base Bid alone.

**9. SUBMISSION OF QUESTIONS:**

- 9.1.** The Director (or Designee) of the Purchasing & Contracting Department is the officer responsible for opening, examining, and evaluating the competitive Bids submitted to the City for the acquisition, construction and completion of any public improvement except when otherwise set forth in these documents. Any questions related to this solicitation shall be submitted to:

Rosa Riego, Senior Contract Specialist at [RRiego@sandiego.gov](mailto:RRiego@sandiego.gov)

- 9.2.** Questions received less than 14 days prior to the date for opening of Bids may not be considered.
- 9.3.** Questions or clarifications deemed by the City to be material shall be answered via issuance of an addendum and posted to the City's online bidding service.
- 9.4.** Only questions answered by formal written addenda shall be binding. Oral and other interpretations or clarifications shall be without legal effect. It is the Bidder's responsibility to be informed of any addenda that have been issued and to include all such information in its Bid.

## INSTRUCTIONS TO BIDDERS

### 1. PREQUALIFICATION OF CONTRACTORS:

- 1.1. Contractors submitting a Bid must be pre-qualified for the total amount proposed, including all alternate items, prior to the date of submittal. Bids from contractors who have not been pre-qualified as applicable and Bids that exceed the maximum dollar amount at which contractors are pre-qualified may be deemed **non-responsive** and ineligible for award.
- 1.2. If the applicant is a subsidiary of a parent company, the applicant may provide the consolidated audited financial statement of the parent company; provided, however, that the applicant submits a statement signed by a duly authorized representative of the parent company confirming that the parent company will guarantee the performance of any contract awarded to the applicant. The City may also require the parent company to execute a separate agreement with the City to guarantee the subsidiary's performance prior to executing any contract with the subsidiary.
- 1.3. The completed application must be submitted online no later than 2 weeks prior to the bid opening.
- 1.4. **Joint Venture Bidders Cumulative Maximum Bidding Capacity:** For projects with an engineer's estimate of \$30,000,000 or greater, Joint Ventures submitting bids may be deemed responsive and eligible for award if the cumulative maximum bidding capacity of the individual Joint Venture entities is equal to or greater than the total amount proposed.
  - 1.4.1. Each of the entities of the Joint Venture must have been previously prequalified at a minimum of \$15,000,000.
  - 1.4.2. Bids submitted with a total amount proposed of less than \$30,000,000 are not eligible for Cumulative Maximum Bidding Capacity prequalification. To be eligible for award in this scenario, the Joint Venture itself or at least one of the Joint Venture entities must have been prequalified for the total amount proposed.
  - 1.4.3. Bids submitted by Joint Ventures with a total amount proposed of \$30,000,000 or greater on a project with an engineer's estimate of less than \$30,000,000 are not eligible for Cumulative Maximum Bidding Capacity prequalification.
  - 1.4.4. The Joint Venture designated as the Apparent Low Bidder shall provide evidence of its corporate existence and furnish good and approved bonds in the name of the Joint Venture within 14 Calendar Days of receipt by the Bidder of a form of contract for execution.
- 1.5. Complete information and links to the on-line prequalification application are available at:  
<http://www.sandiego.gov/cip/bidopps/prequalification>

1.6. Due to the City's responsibility to protect the confidentiality of the contractors' information, City staff will not be able to provide information regarding contractors' prequalification status over the telephone. Contractors may access real-time information about their prequalification status via their vendor profile on [PlanetBids.™](#)

2. **ELECTRONIC FORMAT RECEIPT AND OPENING OF BIDS:** Bids will be received in electronic format (eBids) EXCLUSIVELY at the City of San Diego's electronic bidding (eBidding) site, at: <http://www.sandiego.gov/cip/bidopps/> and are due by the date, and time shown on the cover of this solicitation.

2.1. **BIDDERS MUST BE PRE-REGISTERED** with the City's bidding system and possess a system-assigned Digital ID in order to submit an electronic bid.

2.2. The City's bidding system will automatically track information submitted to the site including IP addresses, browsers being used and the URLs from which information was submitted. In addition, the City's bidding system will keep a history of every login instance including the time of login, and other information about the user's computer configuration such as the operating system, browser type, version, and more. Because of these security features, Contractors who disable their browsers' cookies will not be able to log in and use the City's bidding system.

2.3. The City's electronic bidding system is responsible for bid tabulations. Upon the bidder's or proposer's entry of their bid, the system will ensure that all required fields are entered. **The system will not accept a bid for which any required information is missing.** This includes all necessary pricing, subcontractor listing(s) and any other essential documentation and supporting materials and forms requested or contained in these solicitation documents.

2.4. **BIDS REMAIN SEALED UNTIL BID DEADLINE.** eBids are transmitted into the City's bidding system via hypertext transfer protocol secure (https) mechanism using SSL 128-256 bit security certificates issued from Verisign/Thawte which encrypts data being transferred from client to server. Bids submitted prior to the "Bid Due Date and Time" are not available for review by anyone other than the submitter who has until the "Bid Due Date and Time" to change, rescind or retrieve its proposal should it desire to do so.

2.5. **BIDS MUST BE SUBMITTED BY BID DUE DATE AND TIME.** Once the bid deadline is reached, no further submissions are accepted into the system. Once the Bid Due Date and Time has lapsed, bidders, proposers, the general public, and City staff are able to immediately see the results on line. City staff may then begin reviewing the submissions for responsiveness, EOCB compliance and other issues. The City may require any Bidder to furnish statement of experience, financial responsibility, technical ability, equipment, and references.

**2.6. RECAPITULATION OF THE WORK.** Bids shall not contain any recapitulation of the Work. Conditional Bids may be rejected as being non-responsive. Alternative proposals will not be considered unless called for.

**2.7. BIDS MAY BE WITHDRAWN** by the Bidder only up to the bid due date and time.

**2.7.1. Important Note:** Submission of the electronic bid into the system may not be instantaneous. Due to the speed and capabilities of the user's internet service provider (ISP), bandwidth, computer hardware and other variables, it may take time for the bidder's submission to upload and be received by the City's eBidding system. It is the bidder's sole responsibility to ensure their bids are received on time by the City's eBidding system. The City of San Diego is not responsible for bids that do not arrive by the required date and time.

**2.8. ACCESSIBILITY AND AMERICANS WITH DISABILITIES ACT (ADA) COMPLIANCE:** To request a copy of this solicitation in an alternative format, contact the Purchasing & Contracting Department, Public Works Division Contract Specialist listed on the cover of this solicitation at least five (5) working days prior to the Bid/Proposal due date to ensure availability.

**3. ELECTRONIC BID SUBMISSIONS CARRY FULL FORCE AND EFFECT:**

**3.1.** The bidder, by submitting its electronic bid, acknowledges that doing so carries the same force and full legal effect as a paper submission with a longhand (wet) signature.

**3.2.** By submitting an electronic bid, the bidder certifies that the bidder has thoroughly examined and understands the entire Contract Documents (which consist of the plans and specifications, drawings, forms, affidavits and the solicitation documents), and that by submitting the eBid as its bid proposal, the bidder acknowledges, agrees to and is bound by the entire Contract Documents, including any addenda issued thereto, and incorporated by reference in the Contract Documents.

**3.3.** The Bidder, by submitting its electronic bid, agrees to and certifies under penalty of perjury under the laws of the State of California, that the certification, forms and affidavits submitted as part of this bid are true and correct.

**3.4.** The Bidder agrees to the construction of the project as described in "Attachment A – Scope of Work" for the City of San Diego, in accordance with the requirements set forth herein for the electronically submitted prices. The Bidder guarantees the Contract Price for a period of 120 days from the date of Bid opening. The duration of the Contract Price guarantee shall be extended by the number of days required for the City to obtain all items necessary to fulfill all conditions precedent.

**4. BIDS ARE PUBLIC RECORDS:** Upon receipt by the City, Bids shall become public records subject to public disclosure. It is the responsibility of the respondent to clearly identify any

confidential, proprietary, trade secret or otherwise legally privileged information contained within the Bid. General references to sections of the California Public Records Act (PRA) will not suffice. If the Contractor does not provide applicable case law that clearly establishes that the requested information is exempt from the disclosure requirements of the PRA, the City shall be free to release the information when required in accordance with the PRA, pursuant to any other applicable law, or by order of any court or government agency, and the Contractor will hold the City harmless for release of this information.

**5. CONTRACTOR REGISTRATION AND ELECTRONIC REPORTING SYSTEM:**

**5.1.** **Prior** to the Award of the Contract or Task Order, you and your Subcontractors and Suppliers must register with the City’s web-based vendor registration and bid management system. For additional information go to:

<http://www.sandiego.gov/purchasing/bids-contracts/vendorreg>

**5.2.** The City may not award the contract until registration of all subcontractors and suppliers is complete. In the event this requirement is not met within the time frame specified in the Notice of Intent to Award letter, the City reserves the right to rescind the Notice of Award / Intent to Award and to make the award to the next responsive and responsible bidder / proposer.

**6. JOINT VENTURE CONTRACTORS:** Provide a copy of the Joint Venture agreement and the Joint Venture license to the City within 14 Calendar Days after receiving the Contract forms.

**7. INSURANCE REQUIREMENTS:**

**7.1.** All certificates of insurance and endorsements required by the contract are to be provided upon issuance of the City’s Notice of Intent to Award letter.

**7.2.** Refer to sections 5-4, “INSURANCE” of the Supplementary Special Provisions (SSP) for the insurance requirements which must be met.

**8. REFERENCE STANDARDS:** Except as otherwise noted or specified, the Work shall be completed in accordance with the following standards:

Title	Edition	Document Number
Standard Specifications for Public Works Construction (“The GREENBOOK”) <a href="http://www.greenbookspecs.org/">http://www.greenbookspecs.org/</a>	2021	ECPI010122-01
City of San Diego Standard Specifications for Public Works Construction (“The WHITEBOOK”)* <a href="https://www.sandiego.gov/ecp/edocref/greenbook">https://www.sandiego.gov/ecp/edocref/greenbook</a>	2021	ECPI010122-02
City of San Diego Standard Drawings* <a href="https://www.sandiego.gov/ecp/edocref/standarddraw">https://www.sandiego.gov/ecp/edocref/standarddraw</a>	2021	ECPI010122-03

Title	Edition	Document Number
Citywide Computer Aided Design and Drafting (CADD) Standards <a href="https://www.sandiego.gov/ecp/edocref/drawings">https://www.sandiego.gov/ecp/edocref/drawings</a>	2018	PWPI010119-04
California Department of Transportation (CALTRANS) Standard Specifications <a href="https://dot.ca.gov/programs/design/july-2023-ccs-standard-plans-and-standard-specifications">https://dot.ca.gov/programs/design/july-2023-ccs-standard-plans-and-standard-specifications</a>	2023	ECPD092023-05
CALTRANS Standard Plans <a href="https://dot.ca.gov/programs/design/july-2023-ccs-standard-plans-and-standard-specifications">https://dot.ca.gov/programs/design/july-2023-ccs-standard-plans-and-standard-specifications</a>	2023	ECPD092023-06
California Manual on Uniform Traffic Control Devices Revision 9 (CA MUTCD Rev 9) <a href="https://dot.ca.gov/programs/safety-programs/camutcd">https://dot.ca.gov/programs/safety-programs/camutcd</a>	2014	ECPD080725-07
<p><b>NOTE:</b> *Available online under Engineering Documents and References at: <a href="https://www.sandiego.gov/ecp/edocref/">https://www.sandiego.gov/ecp/edocref/</a></p> <p>*Electronic updates to the Standard Drawings may also be found in the link above</p>		

9. **CITY'S RESPONSES AND ADDENDA:** The City, at its discretion, may respond to any or all questions submitted in writing via the City's eBidding web site in the **form of an addendum**. No other responses to questions, oral or written shall be of any force or effect with respect to this solicitation. The changes to the Contract Documents through addenda are made effective as though originally issued with the Bid. The Bidders shall acknowledge the receipt of Addenda at the time of bid submission.
10. **CITY'S RIGHTS RESERVED:** The City reserves the right to cancel the Notice Inviting Bids at any time, and further reserves the right to reject submitted Bids, without giving any reason for such action, at its sole discretion and without liability. Costs incurred by the Bidder(s) as a result of preparing Bids under the Notice Inviting Bids shall be the sole responsibility of each bidder. The Notice Inviting Bids creates or imposes no obligation upon the City to enter a contract.
11. **CONTRACT PRICING:** This solicitation is for a Lump Sum contract with Unit Price provisions as set forth herein. The Bidder agrees to perform construction services for the City of San Diego in accordance with these contract documents for the prices listed below. The Bidder further agrees to guarantee the Contract Price for a period of 120 days from the date of Bid opening. The duration of the Contract Price guarantee may be extended, by mutual consent of the parties, by the number of days required for the City to obtain all items necessary to fulfill all contractual conditions.
12. **SUBCONTRACTOR INFORMATION:**
  - 12.1. **LISTING OF SUBCONTRACTORS.** In accordance with the requirements provided in the "Subletting and Subcontracting Fair Practices Act" of the California Public Contract Code, the Bidder shall provide the **NAME** and **ADDRESS** of each Subcontractor who will perform work, labor, render services or who specially fabricates and installs a portion [type] of the work or improvement, in an amount in excess of 0.5% of the Contractor's total Bid. The Bidder shall also state within the description, whether the

subcontractor is a **CONSTRUCTOR, CONSULTANT** or **SUPPLIER**. The Bidder shall state the **DIR REGISTRATION NUMBER** for all subcontractors and shall further state within the description, the **PORTION** of the work which will be performed by each subcontractor under this Contract. The Contractor shall list only one Subcontractor for each portion of the Work. The **DOLLAR VALUE** of the total Bid to be performed shall be stated for all subcontractors listed. Failure to comply with this requirement may result in the Bid being rejected as **non-responsive** and ineligible for award. The Bidder's attention is directed to the Special Provisions – Section 3-2, “Self-Performance”, which stipulates the percent of the Work to be performed with the Bidders' own forces. The Bidder shall list all SLBE, ELBE, DBE, DVBE, MBE, WBE, OBE, SDB, WoSB, HUBZone, and SDVOSB Subcontractors for which Bidders are seeking recognition towards achieving any mandatory, voluntary (or both) subcontracting participation goals.

Additionally, pursuant to California Senate Bill 96 and in accordance with the requirements of Labor Code sections 1771.1 and 1725.5, by submitting a bid or proposal to the City, Contractor is certifying that he or she has verified that all subcontractors used on this public work project are registered with the California Department of Industrial Relations (DIR). **The Bidder shall provide the name, address, license number, DIR registration number of any Subcontractor – regardless of tier** - who will perform work, labor, render services or specially fabricate and install a portion [type] of the work or improvement pursuant to the contract.

**12.2. LISTING OF SUPPLIERS.** Any Bidder seeking the recognition of Suppliers of equipment, materials, or supplies obtained from third party Suppliers towards achieving any mandatory or voluntary (or both) subcontracting participation goals shall provide, at a minimum, the **NAME, LOCATION (CITY), DIR REGISTRATION NUMBER** and the **DOLLAR VALUE** of each supplier. The Bidder will be credited up to 60% of the amount to be paid to the Suppliers for materials and supplies unless vendor manufactures or substantially alters materials and supplies, in which case, 100% will be credited. The Bidder is to indicate within the description whether the listed firm is a supplier or manufacturer. If no indication is provided, the listed firm will be credited at 60% of the listed dollar value for purposes of calculating the Subcontractor Participation Percentage.

**12.3. LISTING OF SUBCONTRACTORS OR SUPPLIERS FOR ALTERNATES.** For subcontractors or suppliers to be used on alternate items, bidder shall use the provided **“Subcontractors For Alternates”** form and shall indicate for each alternate subcontract whether it is an additive or deductive alternate; the subcontractor's name, location, phone number, email address, CA license number, and DIR registration number; whether the subcontractor is a designer, constructor or supplier; the type of work the subcontractor will be performing; and the dollar value of the subcontract for that alternate item. Failure to comply with this requirement may result in the bid being rejected as nonresponsive and ineligible for award.

**13. SUBMITTAL OF “OR EQUAL” ITEMS:** See Section 4-6, “Trade Names” in The WHITEBOOK and as amended in the SSP.

- 14. AWARD:**
- 14.1.** The Award of this contract is contingent upon the Contractor's compliance with all conditions precedent to Award.
- 14.2.** Upon acceptance of a Bid, the City will prepare contract documents for execution within approximately 21 days of the date of the Bid opening and award the Contract approximately within 7 days of receipt of properly executed Contract, bonds, and insurance documents.
- 14.3.** This contract will be deemed executed and effective only upon the signing of the Contract by the Mayor or his designee and approval as to form the City Attorney's Office.
- 15. SUBCONTRACT LIMITATIONS:** The Bidder's attention is directed to Standard Specifications for Public Works Construction, Section 3-2, "SELF-PERFORMANCE" in The GREENBOOK and as amended in the SSP which requires the Contractor to self-perform not less than the specified amount. Failure to comply with this requirement shall render the bid **non-responsive** and ineligible for award.
- 16. AVAILABILITY OF PLANS AND SPECIFICATIONS:** Contract Documents may be obtained by visiting the City's website: <http://www.sandiego.gov/cip/>. Plans and Specifications for this contract are also available for review in the office of the City Clerk or Purchasing & Contracting Department, Public Works Division.
- 17. ONLY ONE BID PER CONTRACTOR SHALL BE ACCEPTED:** No person, firm, or corporation shall be allowed to make, file, or be interested in more than one (1) Bid for the same work unless alternate Bids are called for. A person, firm or corporation who has submitted a sub-proposal to a Bidder, or who has quoted prices on materials to a Bidder, is not hereby disqualified from submitting a sub-proposal or quoting prices to other Bidders or from submitting a Bid in its own behalf. Any Bidder who submits more than one bid will result in the rejection of all bids submitted.
- 18. SAN DIEGO BUSINESS TAX CERTIFICATE:** The Contractor and Subcontractors, not already having a City of San Diego Business Tax Certificate for the work contemplated shall secure the appropriate certificate from the City Treasurer, Civic Center Plaza, First floor and submit to the Contract Specialist upon request or as specified in the Contract Documents. Tax Identification numbers for both the Bidder and the listed Subcontractors must be submitted on the City provided forms within these documents.
- 19. BIDDER'S GUARANTEE OF GOOD FAITH (BID SECURITY) FOR DESIGN-BID-BUILD CONTRACTS:**
- 19.1.** For bids \$250,000 and above, bidders shall submit Bid Security at bid time. Bid Security shall be in one of the following forms: a cashier's check, or a properly certified check upon some responsible bank; or an approved corporate surety bond payable to the City of San Diego for an amount of not less than 10% of the total bid amount.
- 19.2.** This check or bond, and the monies represented thereby, will be held by the City as a guarantee that the Bidder, if awarded the contract, will in good faith enter into the contract and furnish the required final performance and payment bonds.

- 19.3. The Bidder agrees that in the event of the Bidder's failure to execute this contract and provide the required final bonds, the money represented by the cashier's or certified check will remain the property of the City; and the Surety agrees that it will pay to the City the damages, not exceeding the sum of 10% of the amount of the Bid, that the City may suffer as a result of such failure.
- 19.4. At the time of bid submission, bidders must upload and submit an electronic PDF copy of the aforementioned bid security. Whether in the form of a cashier's check, a properly certified check or an approved corporate surety bond payable to the City of San Diego, the bid security must be uploaded to the City's eBidding system. By 5PM, 1 working day after the bid opening date, all bidders must provide the City with the original bid security.
- 19.5. Failure to submit the electronic version of the bid security at the time of bid submission AND failure to provide the original by 5PM, 1 working day after the bid opening date shall cause the bid to be rejected and deemed **non-responsive**.

Original Bid Bond shall be submitted to:  
Purchasing & Contracting Department, Public Works Division  
1200 3rd Ave., Suite 200, MS 56P  
San Diego, California, 92101  
To the Attention of the Contract Specialist on the Front Page of this solicitation.

## **20. AWARD OF CONTRACT OR REJECTION OF BIDS:**

- 20.1. This contract may be awarded to the lowest responsible and reliable Bidder.
- 20.2. Bidders shall complete ALL eBid forms as required by this solicitation. Incomplete eBids will not be accepted.
- 20.3. The City reserves the right to reject any or all Bids, to waive any informality or technicality in Bids received, and to waive any requirements of these specifications as to bidding procedure.
- 20.4. Bidders will not be released on account of their errors of judgment. Bidders may be released only upon receipt by the City within 3 Working Days of the bid opening, written notice from the Bidder which shows proof of honest, credible, clerical error of a material nature, free from fraud or fraudulent intent; and of evidence that reasonable care was observed in the preparation of the Bid.
- 20.5. A bidder who is not selected for contract award may protest the award of a contract to another bidder by submitting a written protest in accordance with the San Diego Municipal Code.
- 20.6. The City of San Diego will not discriminate in the award of contracts with regard to race, religion creed, color, national origin, ancestry, physical handicap, marital status, sex or age.
- 20.7. Each Bid package properly signed as required by these specifications shall constitute a firm offer which may be accepted by the City within the time specified herein.
- 20.8. The City reserves the right to evaluate all Bids and determine the lowest Bidder on the basis of the base bid and any proposed alternates or options as detailed herein.

**21. BID RESULTS:**

- 21.1.** The availability of the bids on the City's eBidding system shall constitute the public announcement of the apparent low bidder. In the event that the apparent low bidder is subsequently deemed non-responsive or non-responsible, a notation of such will be made on the eBidding system. The new ranking and apparent low bidder will be adjusted accordingly.
- 21.2.** To obtain the bid results, view the results on the City's web site, or request the results by U.S. mail and provide a self-addressed, stamped envelope. If requesting by mail, be sure to reference the bid name and number. The bid tabulations will be mailed to you upon their completion. The results will not be given over the telephone.

**22. THE CONTRACT:**

- 22.1.** The Bidder to whom award is made shall execute a written contract with the City of San Diego and furnish good and approved bonds and insurance certificates specified by the City within 14 days after receipt by Bidder of a form of contract for execution unless an extension of time is granted to the Bidder in writing.
- 22.2.** If the Bidder takes longer than 14 days to fulfill these requirements, then the additional time taken shall be added to the Bid guarantee. The Contract shall be made in the form adopted by the City, which includes the provision that no claim or suit whatsoever shall be made or brought by Contractor against any officer, agent, or employee of the City for or on account of anything done or omitted to be done in connection with this contract, nor shall any such officer, agent, or employee be liable hereunder.
- 22.3.** If the Bidder to whom the award is made fails to enter into the contract as herein provided, the award may be annulled and the Bidder's Guarantee of Good Faith will be subject to forfeiture. An award may be made to the next lowest responsible and reliable Bidder who shall fulfill every stipulation embraced herein as if it were the party to whom the first award was made.
- 22.4.** Pursuant to the San Diego City Charter section 94, the City may only award a public works contract to the lowest responsible and reliable Bidder. The City will require the Apparent Low Bidder to (i) submit information to determine the Bidder's responsibility and reliability, (ii) execute the Contract in form provided by the City, and (iii) furnish good and approved bonds and insurance certificates specified by the City within 14 Days, unless otherwise approved by the City, in writing after the Bidder receives notification from the City, designating the Bidder as the Apparent Low Bidder and formally requesting the above mentioned items.
- 22.5.** The award of the Contract is contingent upon the satisfactory completion of the above-mentioned items and becomes effective upon the signing of the Contract by the Mayor or designee and approval as to form by the City Attorney's Office. If the Apparent Low Bidder does not execute the Contract or submit required documents and information, the City may award the Contract to the next lowest responsible and reliable Bidder

who shall fulfill every condition precedent to award. A corporation designated as the Apparent Low Bidder shall furnish evidence of its corporate existence and evidence that the officer signing the Contract and bond for the corporation is duly authorized to do so.

- 23. EXAMINATION OF PLANS, SPECIFICATIONS, AND SITE OF WORK:** The Bidder shall examine carefully the Project Site, the Plans and Specifications, other materials as described in the Special Provisions, Section 3-9, "TECHNICAL STUDIES AND SUBSURFACE DATA", and the proposal forms (e.g., Bidding Documents). The submission of a Bid shall be conclusive evidence that the Bidder has investigated and is satisfied as to the conditions to be encountered, as to the character, quality, and scope of work, the quantities of materials to be furnished, and as to the requirements of the Bidding Documents Proposal, Plans, and Specifications.
- 24. CITY STANDARD PROVISIONS:** This contract is subject to the following standard provisions. See The WHITEBOOK for details.
- 24.1.** The City of San Diego Resolution No. R-277952 adopted on May 20, 1991 for a Drug-Free Workplace.
- 24.2.** The City of San Diego Resolution No. R-282153 adopted on June 14, 1993 related to the Americans with Disabilities Act.
- 24.3.** The City of San Diego Municipal Code §22.3004 for Contractor Standards.
- 24.4.** The City of San Diego's Labor Compliance Program and the State of California Labor Code §§1771.5(b) and 1776.
- 24.5.** Sections 1777.5, 1777.6, and 1777.7 of the State of California Labor Code concerning the employment of apprentices by contractors and subcontractors performing public works contracts.
- 24.6.** The City's Equal Benefits Ordinance (EBO), Chapter 2, Article 2, Division 43 of The San Diego Municipal Code (SDMC).
- 24.7.** The City's Information Security Policy (ISP) as defined in the City's Administrative Regulation 90.63.
- 25. PRE-AWARD ACTIVITIES:**
- 25.1.** The contractor selected by the City to execute a contract for this Work shall submit the required documentation as specified herein and in the Notice of Intent to Award. Failure to provide the information as specified may result in the Bid being rejected as **non-responsive**.
- 25.2.** The decision that bid is non-responsive for failure to provide the information required within the time specified shall be at the sole discretion of the City.

BOND NO. 7901307192  
PREMIUM: \$12,848.00

PROJECT: TORREY PINES PROSPECT-COAST  
WALK GUARDRAIL; Bid No. K-26-2448-DBB-3;

PREMIUM IS FOR CONTRACT TERM  
AND IS SUBJECT TO ADJUSTMENT  
BASED ON FINAL CONTRACT PRICE

**PERFORMANCE BOND, LABOR AND MATERIALMEN'S BOND**

**FAITHFUL PERFORMANCE BOND AND LABOR AND MATERIALMEN'S BOND:**

Palm Engineering Construction Co., Inc., a corporation, as principal, and Nationwide Mutual Insurance Company, a corporation authorized to do business in the State of California, as Surety, hereby obligate themselves, their successors and assigns, jointly and severally, to The City of San Diego a municipal corporation in the sum of One Million Three Hundred Thirteen Thousand Two Hundred Twenty Six Dollars and Zero Cents (\$1,313,226.00) for the faithful performance of the annexed contract, and in the sum of One Million Three Hundred Thirteen Thousand Two Hundred Twenty Six Dollars and Zero Cents (\$1,313,226.00) for the benefit of laborers and materialmen designated below.

**Conditions:**

If the Principal shall faithfully perform the annexed contract with the City of San Diego, California, then the obligation herein with respect to a faithful performance shall be void; otherwise it shall remain in full force.

If the Principal shall promptly pay all persons, firms and corporations furnishing materials for or performing labor in the execution of this contract, and shall pay all amounts due under the California Unemployment Insurance Act then the obligation herein with respect to laborers and materialmen shall be void; otherwise it shall remain in full force.

The obligation herein with respect to laborers and materialmen shall inure to the benefit of all persons, firms and corporations entitled to file claims under the provisions of Article 2. Claimants, (iii) public works of improvement commencing with Civil Code Section 9100 of the Civil Code of the State of California.

Changes in the terms of the annexed contract or specifications accompanying same or referred to therein shall not affect the Surety's obligation on this bond, and the Surety hereby waives notice of same.

The Surety shall pay reasonable attorney's fees should suit be brought to enforce the provisions of this bond.

The Surety expressly agrees that the City of San Diego may reject any contractor or subcontractor which may be proposed by Surety in fulfillment of its obligations in the event of default by the Principal.

The Surety shall not utilize the Principal in completing the improvements and work specified in the Agreement in the event the City terminates the Principal for default.

PERFORMANCE BOND, LABOR AND MATERIALMEN'S BOND (continued)

Palm Engineering  
Construction Company, Inc.  
CONTRACTOR

By: R. N.

Print Name: Rasoul Shahbazi, President

Date: 04/03/2026

THE CITY OF SAN DIEGO

By: Stephen Samara

Print Name: Stephen Samara  
Principal Contract Specialist  
Purchasing & Contracting Department

Date: 5/7/2026

Nationwide Mutual Insurance Company  
SURETY

By: J.

Print Name: Lawrence F. McMahon, Attorney-In-Fact  
Attorney-In-Fact

Date: April 2, 2026

500 North Brand Drive, Suite 2000  
Glendale, CA 91203

Local Address of Surety

(949) 606-3819

Local Phone Number of Surety

\$12,848.00 PREMIUM IS FOR CONTRACT TERM  
AND IS SUBJECT TO ADJUSTMENT  
BASED ON FINAL CONTRACT PRICE

Premium

7901307192

Bond Number

APPROVED AS TO FORM  
Heather Ferbert, City Attorney

By: Ryan P. Gerrito

Print Name: RYAN P. GERRITO  
Deputy City Attorney

Date: 5/13/2026

**CALIFORNIA ALL-PURPOSE ACKNOWLEDGMENT** Civil Code § 1189

A notary public or other officer completing this certificate verifies only the identity of the individual who signed the document, to which this certificate is attached, and not the truthfulness, accuracy or validity of that document.

STATE OF CALIFORNIA

County of San Diego

On 4/2/2026 before me, Sandra Figueroa, Notary Public,  
Date Insert Name of Notary exactly as it appears on the official seal

personally appeared Lawrence F. McMahon  
Name(s) of Signer(s)

who proved to me on the basis of satisfactory evidence to be the person(##) whose name(##) is/##/## subscribed to the within instrument and acknowledged to me that he/she/they executed the same in his/her/their authorized capacity(##/##), and that by his/her/their signature(##) on the instrument the person(##), or the entity upon behalf of which the person(##) acted, executed the instrument.

I certify under PENALTY OF PERJURY under the laws of the State of California that the foregoing paragraph is true and correct.

Witness my hand and official seal.

Signature [Signature]  
Signature of Notary Public

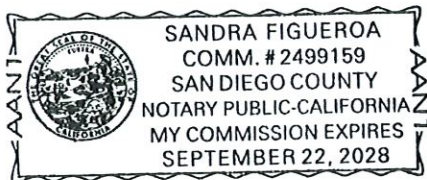

Place Notary Seal Above

**OPTIONAL**

Though the information below is not required by law, it may prove valuable to persons relying on the document and could prevent fraudulent removal and reattachment of the form to another document.

**Description of Attached Document**

Title or Type of Document: \_\_\_\_\_

Document Date: \_\_\_\_\_ Number of Pages: \_\_\_\_\_

Signer(s) Other Than Named Above: \_\_\_\_\_

**Capacity(ies) Claimed by Signer(s)**

Signer's Name: Lawrence F. McMahon

- Individual
- Corporate Officer — Title(s): \_\_\_\_\_
- Partner  Limited  General
- Attorney in Fact
- Trustee
- Guardian or Conservator
- Other: \_\_\_\_\_

**RIGHT THUMBPRINT OF SIGNER**  
Top of thumb here

Signer is Representing:  
\_\_\_\_\_  
\_\_\_\_\_  
\_\_\_\_\_

Signer's Name: \_\_\_\_\_

- Individual
- Corporate Officer — Title(s): \_\_\_\_\_
- Partner  Limited  General
- Attorney in Fact
- Trustee
- Guardian or Conservator
- Other: \_\_\_\_\_

**RIGHT THUMBPRINT OF SIGNER**  
Top of thumb here

Signer is Representing:  
\_\_\_\_\_  
\_\_\_\_\_  
\_\_\_\_\_

Power of Attorney

KNOW ALL MEN BY THESE PRESENTS THAT:

Nationwide Mutual Insurance Company, an Ohio corporation

hereinafter referred to severally as the "Company" and collectively as "the Companies" does hereby make, constitute and appoint:

CHRISTOPHER CONTE; DALE G HARSHAW; GEOFFREY SHELTON; JANICE MARTIN; JOHN R QUALIN; LAWRENCE F MCMAHON; MARIA GUISE; MINNA HUOVILA; RYAN WARNOCK; SARAH MYERS; TARA BACON

each in their individual capacity, its true and lawful attorney-in-fact, with full power and authority to sign, seal, and execute on its behalf on the date thereof any and all: (i) bonds and undertakings; (ii) Proposal Bonds; (ii) Letters of Surety; (iv) Consent of Surety; and (v) other obligatory instruments of similar nature, in penalties not exceeding the sum of

UNLIMITED

and to bind the Company thereby, as fully and to the same extent as if such instruments were signed by the duly authorized officers of the Company; and all acts of said Attorney pursuant to the authority given are hereby ratified and confirmed.

This power of attorney is made and executed pursuant to and by authority of the following resolution duly adopted by the board of directors of the Company:

"RESOLVED, that the president, or any vice president be, and each hereby is, authorized and empowered to appoint attorneys-in-fact of the Company, and to authorize them to execute and deliver on behalf of the Company any and all bonds, forms, applications, memorandums, undertakings, recognizances, transfers, contracts of indemnity, policies, contracts guaranteeing the fidelity of persons holding positions of public or private trust, and other writings obligatory in nature that the business of the Company may require; and to modify or revoke, with or without cause, any such appointment or authority; provided, however, that the authority granted hereby shall in no way limit the authority of other duly authorized agents to sign and countersign any of said documents on behalf of the Company."

"RESOLVED FURTHER, that such attorneys-in-fact shall have full power and authority to execute and deliver any and all such documents and to bind the Company subject to the terms and limitations of the power of attorney issued to them, and to affix the seal of the Company thereto; provided, however, that said seal shall not be necessary for the validity of any such documents."

This power of attorney is signed and sealed under and by the following bylaws duly adopted by the board of directors of the Company.

Execution of Instruments. Any vice president, any assistant secretary or any assistant treasurer shall have the power and authority to sign or attest all approved documents, instruments, contracts, or other papers in connection with the operation of the business of the company in addition to the chairman of the board, the chief executive officer, president, treasurer or secretary; provided, however, the signature of any of them may be printed, engraved, or stamped on any approved document, contract, instrument, or other papers of the Company.

IN WITNESS WHEREOF, the Company has caused this instrument to be sealed and duly attested by the signature of its officer the 23rd day of October, 2025.

*[Handwritten Signature]*

Antonio C. Albanese, Vice President of Nationwide Mutual Insurance Company

ACKNOWLEDGMENT

STATE OF OHIO COUNTY OF FRANKLIN: ss

On this 23rd day of October, 2025, before me came the above-named officer for the Company aforesaid, to me personally known to be the officer described in and who executed the preceding instrument, and he acknowledged the execution of the same, and being by me duly sworn, deposes and says, that he is the officer of the Company aforesaid, that the seal affixed hereto is the corporate seal of said Company, and the said corporate seal and his signature were duly affixed and subscribed to said instrument by the authority and direction of said Company.



Karen L. Karn  
Notary Public, State of Ohio  
No. 2018-RE-719796  
Commission Expires July 7, 2028

*[Handwritten Signature]*

Notary Public  
My Commission Expires  
July 7, 2028

CERTIFICATE

I, Lezlie F. Chimienti, Assistant Secretary of the Company, do hereby certify that the foregoing is a full, true and correct copy of the original power of attorney issued by the Company; that the resolution included therein is a true and correct transcript from the minutes of the meetings of the boards of directors and the same has not been revoked or amended in any manner; that said Antonio C. Albanese was on the date of the execution of the foregoing power of attorney the duly elected officer of the Company, and the corporate seal and his signature as officer were duly affixed and subscribed to the said instrument by the authority of said board of directors; and the foregoing power of attorney is still in full force and effect.

IN WITNESS WHEREOF, I have hereunto subscribed my name as Assistant Secretary, and affixed the corporate seal of said Company this 2ND day of

APRIL, 2026.

*[Handwritten Signature]*

Assistant Secretary

## ATTACHMENTS

**ATTACHMENT A**  
**SCOPE OF WORK**

## SCOPE OF WORK

1. **SCOPE OF WORK:** Installation of approximately 420 feet of California ST-75 bridge rail, end blocks, and crash cushions on the north side of Torrey Pines Road between Prospect Place and Coast Walk. Project includes the replacement of sidewalk, and curb and gutter, utility relocations, roadway paving, and traffic striping and signage.
  - 1.1. The Work shall be performed in accordance with:
    - 1.1.1. The Notice Inviting Bids and Plans numbered **0101250-01-D** through **0101250-10-D**, and **0101250-T1-D** through **0101250-T3-D**, inclusive.
2. **LOCATION OF WORK:** The location of the Work is as follows:

See **Appendix E – Location Map**.
3. **CONTRACT TIME:** The Contract Time for completion of the Work shall be **190 Working Days**.

**ATTACHMENT B**

**RESERVED**

**ATTACHMENT C**  
**EQUAL OPPORTUNITY CONTRACTING PROGRAM**

## EQUAL OPPORTUNITY CONTRACTING PROGRAM (EOCP)

### SECTION A - GENERAL REQUIREMENTS

#### A. INTRODUCTION.

1. This document sets forth the following specifications:
  - a) The City's general EOCP requirements for all Construction Contracts.
  - b) Special Provisions for Contracts subject to SLBE and ELBE requirements only.
2. Additional requirements may apply for state or federally funded projects.
3. These requirements shall be included as Contract provisions for all Subcontracts.
4. The City specified forms, instructions, and guides are available for download from the EOCP's web site at: <http://www.sandiego.gov/eoc/forms/>

#### B. GENERAL.

1. The City of San Diego promotes equal employment and subcontracting opportunities.
2. The City is committed to ensuring that taxpayer dollars spent on public Contracts are not paid to businesses that practice discrimination in employment or subcontracting.
3. The City encourages all companies seeking to do business with the City to share this commitment.

#### C. DEFINITIONS.

1. For the purpose of these requirements: Terms "Bid" and "Proposal", "Bidder" and "Proposer", "Subcontractor" and "Subconsultant", "Contractor" and "Consultant", "Contractor" and "Prime Contractor", "Consultant" and "Professional Service Provider", "Suppliers" and "Vendors", "Suppliers" and "Dealers", and "Suppliers" and "Manufacturers" may have been used interchangeably.
2. The following definitions apply:
  - a) **Emerging Business Enterprise (EBE)** - A for-profit business that is independently owned and operated; that is not a subsidiary or franchise of another business and whose gross annual receipts do not exceed the amount set by the City Manager and that meets all other criteria set forth in regulations implementing Municipal Code Chapter 2, Article 2, Division 36. The City Manager shall review the threshold amount for EBEs on an annual basis and adjust as necessary to reflect changes in the marketplace.
  - b) **Emerging Local Business Enterprise (ELBE)** - A Local Business Enterprise that is also an Emerging Business Enterprise.

- c) **Minority Business Enterprise (MBE)** - A certified business that is at least fifty-one percent (51%) owned by one or more minority individuals, or, in the case of a publicly owned business at least fifty-one percent (51%) of the stock is owned by one or more minority individuals; and (2) whose daily business operations are managed and directed by one or more minorities owners. Minorities include the groups with the following ethnic origins: African, Asian Pacific, Asian Subcontinent, Hispanic, Native Alaskan, Native American, and Native Hawaiian.
- d) **Women Business Enterprise (WBE)** - A certified business that is at least fifty-one percent (51%) owned by a woman or women, or, in the case of a publicly owned business at least fifty-one percent (51%) of the stock is owned by one or more women; and (2) whose daily business operations are managed and directed by one or more women owners.
- e) **Disadvantaged Business Enterprise (DBE)** - a certified business that is at least fifty-one percent (51%) owned by socially and economically disadvantaged individuals, or, in the case of a publicly owned business at least fifty-one percent (51%) of the stock is owned by one or more socially and economically disadvantaged individuals; and (2) whose daily business operations are managed and directed by one or more socially and economically disadvantaged owners.
- f) **Disabled Veteran Business Enterprise (DVBE)** - A certified business that is at least fifty-one percent (51%) owned by one or more disabled veterans; and (2) business operations must be managed and controlled by one or more disabled veterans. Disabled Veteran is a veteran of the U.S. military, naval, or air service; the veteran must have a service-connected disability of at least 10% or more; and the veteran must reside in California.
- g) **Other Business Enterprise (OBE)** - Any business which does not otherwise qualify as a Minority, Woman, Disadvantaged, or Disabled Veteran Business Enterprise.
- h) **Small Business Enterprise (SBE)** - A for-profit business that is independently owned and operated; that is not a subsidiary or franchise of another business and whose gross annual receipts do not exceed the amount set by the City Manager and that meets all other criteria set forth in regulations implementing Municipal Code Chapter 2, Article 2, Division 36. The City Manager shall review the threshold amount for SBEs on an annual basis and adjust as necessary to reflect changes in the marketplace. A business certified as a Micro Business (MB) or a Disabled Veteran Business Enterprise (DVBE) by the State of California and that has provided proof of such certification to the City Manager shall be deemed to be an SBE.

- i) **Small Local Business Enterprise (SLBE)** - A Local Business Enterprise that is also a Small Business Enterprise.

**D. CITY'S EQUAL OPPORTUNITY COMMITMENT.**

**1. Nondiscrimination in Contracting Ordinance.**

- a) You, your Subcontractors, and Suppliers shall comply with the requirements of the City's Nondiscrimination in Contracting Ordinance, San Diego Municipal Code §§22.3501 through 22.3517.

You shall not discriminate on the basis of race, gender, gender expression, gender identity, religion, national origin, ethnicity, sexual orientation, age, or disability in the solicitation, selection, hiring, or treatment of subcontractors, vendors, or suppliers. You shall provide equal opportunity for Subcontractors to participate in subcontracting opportunities. You understand and agree that the violation of this clause shall be considered a material breach of the Contract and may result in Contract termination, debarment, or other sanctions.

You shall include the foregoing clause in all Contracts between you and your Subcontractors and Suppliers.

- b) **Disclosure of Discrimination Complaints.** As part of its Bid or Proposal, you shall provide to the City a list of all instances within the past 10 years where a complaint was filed or pending against you in a legal or administrative proceeding alleging that you discriminated against your employees, Subcontractors, vendors, or suppliers, and a description of the status or resolution of that complaint, including any remedial action taken.
- c) Upon the City's request, You agree to provide to the City, within 60 Calendar Days, a truthful and complete list of the names of all Subcontractors and Suppliers that you have used in the past 5 years on any of your Contracts that were undertaken within the San Diego County, including the total dollar amount paid by you for each Subcontract or supply Contract.
- d) You further agree to fully cooperate in any investigation conducted by the City pursuant to the City's Nondiscrimination in Contracting Ordinance, Municipal Code §§22.3501 through 22.3517. You understand and agree that violation of this clause shall be considered a material breach of the Contract and may result in remedies being ordered against you up to and including contract termination, debarment, and other sanctions for the violation of the provisions of the Nondiscrimination in Contracting Ordinance. You further understand and agree that the procedures, remedies, and sanctions provided for in the Nondiscrimination in Contracting Ordinance apply only to violations of the Ordinance.

**E. EQUAL EMPLOYMENT OPPORTUNITY OUTREACH PROGRAM.**

1. You, your Subcontractors, and Suppliers shall comply with the City's Equal Employment Opportunity Outreach Program, San Diego Municipal Code §§22.2701 through 22.2707.

You shall not discriminate against any employee or applicant for employment on any basis prohibited by law. You shall provide equal opportunity in all employment practices. You shall ensure that your Subcontractors comply with this program. Nothing in this section shall be interpreted to hold you liable for any discriminatory practices of your Subcontractors.

You shall include the foregoing clause in all Contracts between you and your Subcontractors and Suppliers.

2. If the Contract is competitively solicited, the selected Bidder shall submit a Work Force Report (Form BB05) within 10 Working Days after receipt by the Bidder to the City for approval as specified in the Notice of Intent to Award letter.
3. The selected Bidder shall submit an Equal Employment Opportunity Plan if a Work Force Report is submitted and if the City determines that there are under-representations when compared to County Labor Force Availability data.
4. If the selected Bidder submits an Equal Employment Opportunity Plan, it shall include the following assurances:
  - a) You shall maintain a working environment free of discrimination, harassment, intimidation, and coercion at all Sites and in all facilities at which your employees are assigned to Work.
  - b) You shall review your EEO Policy annually with all on-Site supervisors involved in employment decisions.
  - c) You shall disseminate and review your EEO Policy with all employees at least once a year, post the policy statement and EEO posters on all company bulletin boards and job sites, and document every dissemination, review, and posting with a written record to identify the time, place, employees present, subject matter, and disposition of meetings.
  - d) You shall review, at least annually, all supervisors' adherence to and performance under the EEO Policy and maintain written documentation of these reviews.
  - e) You shall discuss your EEO Policy Statement with Subcontractors with whom you anticipate doing business, including the EEO Policy Statement in your Subcontracts, and provide such documentation to the City upon request.

- f) You shall document and maintain a record of all Bid solicitations and outreach efforts to and from Subcontractors, contractor associations, and other business associations.
- g) You shall disseminate your EEO Policy externally through various media, including the media of people of color and women, in advertisements to recruit. Maintain files documenting these efforts and provide copies of these advertisements to the City upon request.
- h) You shall disseminate your EEO Policy to union and community organizations.
- i) You shall provide immediate written notification to the City when any union referral process has impeded your efforts to maintain your EEO Policy.
- j) You shall maintain a current list of recruitment sources, including those outreaching to people of color and women, and provide written notification of employment opportunities to these recruitment sources with a record of the organizations' responses.
- k) You shall maintain a current file of names, addresses and phone numbers of each walk-in applicant, including people of color and women, and referrals from unions, recruitment sources, or community organizations with a description of the employment action taken.
- l) You shall encourage all present employees, including people of color and women employees, to recruit others.
- m) You shall maintain all employment selection process information with records of all tests and other selection criteria.
- n) You shall develop and maintain documentation for on-the-job training opportunities, participate in training programs, or both for all of your employees, including people of color and women, and establish apprenticeship, trainee, and upgrade programs relevant to your employment needs.
- o) You shall conduct, at least annually, an inventory and evaluation of all employees for promotional opportunities and encourage all employees to seek and prepare appropriately for such opportunities.
- p) You shall ensure that the company's working environment and activities are non-segregated except for providing separate or single-user toilets and necessary changing facilities to assure privacy between the sexes.

**F. SUBCONTRACTING.**

1. The City encourages all eligible business enterprises to participate in City contracts as a Contractor, Subcontractor, and joint venture partner with you, your Subcontractors, or your Suppliers. You are encouraged to take positive steps to diversify and expand your Subcontractor solicitation base and to offer

subcontracting opportunities to all eligible business firms including SLBEs, ELBEs, MBEs, WBEs, DBEs, DVBES, and OBEs.

2. For Subcontractor participation level requirements, see the Contract Documents where applicable.
3. For the purposes of achieving the mandatory Subcontractor participation percentages, City percentage calculations will not account for the following:
  - a) "Field Orders" and "City Contingency" Bid items.
  - b) Alternate Bid items.
  - c) Allowance Bid items designated as "EOC Type II".
4. Allowance Bid items designated as "EOC Type I" will be considered as part of the Base Bid and will be included in the percentage calculation.
5. Each joint venture partner shall be responsible for a clearly defined Scope of Work. In addition, an agreement shall be submitted and signed by all parties identifying the extent to which each joint venture partner shares in ownership, control, management, risk, and profits of the joint venture.

**G. LISTS OF SUBCONTRACTORS AND SUPPLIERS.**

1. You shall comply with the Subletting and Subcontracting Fair Practices Act, Public Contract Code §§4100 through 4113, inclusive.
2. You shall list all Subcontractors who will receive more than 0.5% of the total Bid amount or \$10,000, whichever is greater on the form provided in the Contract Documents (Subcontractors list).
3. The Subcontractors list shall include the Subcontractor's name, telephone number including area code, physical address, Scope of Work, the dollar amount of the proposed Subcontract, the California contractor license number, the Public Works contractor registration number issued pursuant to Section 1725.5 of the Labor Code, and the Subcontractor's certification status with the name of the certifying agency.
4. The listed Subcontractor shall be appropriately licensed pursuant to Contractor License Laws.
5. For Design-Build Contracts, refer to the RFQ and RFP for each Project or Task Order.

**H. SUBCONTRACTOR AND SUPPLIER SUBSTITUTIONS.**

1. Listed Subcontractors and Suppliers shall not be substituted without the Express authorization of the City or its duly authorized agent.
2. Request for Subcontractor or Supplier substitution shall be made in writing to Purchasing & Contracting Department, Public Works Division, Attention Contract Specialist, 1200 3rd Ave., Suite 200, MS 56P, San Diego, CA 92101 with a copy to the Engineer.

3. The request shall include a thorough explanation of the reason(s) for the substitution, including dollar amounts and a letter from each substituted Subcontractor or Supplier stating that they (the Subcontractors or Suppliers) release all interest in working on the Project and written confirmation from the new Subcontractor or Supplier stating that they agree to work on the Project along with the dollar value of the Work to be performed.
4. Written approval of the substitution request shall be received by you or from the City or its authorized officer prior to any unlisted Subcontractor or Supplier performing Work on the Project.
5. Substitution of Subcontractors and Suppliers without authorization shall subject you to those penalties set forth in Public Contract Code §4110.
6. Requests for Supplier substitution shall be made in writing at least 10 Days prior to the provision of materials, supplies, or services by the proposed Supplier and shall include proof of written notice to the originally listed Supplier of the proposed substitution.
7. A Contractor whose Bid is accepted shall not:
  - a) Substitute a person as Subcontractor or Supplier in place of the Subcontractor or Supplier listed in the original bid, except that the City, or its duly authorized officer, may consent to the substitution of another person as a Subcontractor or Supplier in any of the following situations:
    - i. When the Subcontractor or Supplier listed in the Bid, after having a reasonable opportunity to do so, fails or refuses to execute a written Contract for the scope of work specified in the subcontractor's bid and at the price specified in the subcontractor's bid, when that written contract, based upon the general terms, conditions, plans, and specifications for the project involved or the terms of the subcontractor's written bid, is presented to the subcontractor by the prime contractor.
    - ii. When the listed Subcontractor or Supplier becomes insolvent or the subject of an order for relief in bankruptcy.
    - iii. When the listed Subcontractor or Supplier fails or refuses to perform his or her subcontract.
    - iv. When the listed Subcontractor fails or refuses to meet bond requirements as set forth in Public Contract Code §4108.
    - v. When you demonstrate to the City or its duly authorized officer, subject to the provisions set forth in Public Contract Code §4107.5, that the name of the Subcontractor was listed as the result of an inadvertent clerical error.
    - vi. When the listed Subcontractor is not licensed pursuant to Contractor License Law.

- vii. When the City, or its duly authorized officer, determines that the Work performed by the listed Subcontractor or that the materials or supplies provided by the listed Supplier are substantially unsatisfactory and not in substantial accordance with the Plans and specifications or that the Subcontractor or Supplier is substantially delaying or disrupting the progress of the Work.
  - viii. When the listed Subcontractor is ineligible to work on a public works project pursuant to §§1777.1 or 1777.7 of the Labor Code.
  - ix. When the City or its duly authorized agent determines that the listed Subcontractor is not a responsible contractor.
- b) Permit a Contract to be voluntarily assigned or transferred or allow it to be performed by anyone other than the original Subcontractor, Supplier listed in the original Bid without the consent of the City, or its duly authorized officer.
  - c) Other than in the performance of "Change Orders" causing changes or deviations from the Contract, sublet or subcontract any portion of the Work, or contract for materials or supplies in excess of 0.5% of your total bid or \$10,000, whichever is greater, as to which his or her original Bid did not designate a Subcontractor or Supplier.
8. Following receipt of notice from you of the proposed substitution of a Subcontractor or Supplier, the listed Subcontractor or Supplier who has been so notified shall have 5 Working Days within which to submit written objections to the substitution to the Contract Specialist with a copy to the Engineer. Failure to file these written objections shall constitute the listed Subcontractor or Supplier's consent to the substitution. If written objections are filed, the City shall give notice in writing of at least 5 Working Days to the listed Subcontractor or Supplier of a hearing by the City on your request for substitution.

**I. PROMPT PAYMENT.**

- 1. You or your Subcontractors shall pay to any subcontractor, not later than 7 Calendar Days of receipt of each progress payment, unless otherwise agreed to in writing, the respective amounts allowed you on account of the Work performed by the Subcontractors, to the extent of each Subcontractor's interest therein. In cases of Subcontractor performance deficiencies, you shall make written notice of any withholding to the Subcontractor with a copy to the Contracts Specialist. Upon correction of the deficiency, you shall pay the Subcontractor the amount previously withheld within 14 Calendar Days after payment by the City.
- 2. Any violation of California Business and Professions Code, §7108.5 concerning prompt payment to Subcontractors shall subject the violating Contractor or

Subcontractor to the penalties, sanctions, and other remedies of that section. This requirement shall not be construed to limit or impair any contractual, administrative, or judicial remedies otherwise available to you or your Subcontractor in the event of a dispute involving late payment or nonpayment by the Prime Contractor, deficient subcontract performance, or noncompliance by a Subcontractor.

**J. PROMPT PAYMENT OF FUNDS WITHHELD TO SUBCONTRACTORS.**

1. The City will hold retention from you and will make prompt and regular incremental acceptances of portions, as determined by the Engineer, of the Work and pay retention to you based on these acceptances.
2. You or your Subcontractors shall return all monies withheld in retention from a Subcontractor within 30 Calendar Days after receiving payment for Work satisfactorily completed and accepted including incremental acceptances of portions of the Work by the City.
3. Federal law (49CFR26.29) requires that any delay or postponement of payment over 30 Calendar Days may take place only for good cause and with the City's prior written approval. Any violation of this provision by you or your Subcontractor shall subject you or your Subcontractor to the penalties, sanctions, and other remedies specified in §7108.5 of the Business and Professions Code.
4. These requirements shall not be construed to limit or impair any contractual, administrative, or judicial remedies otherwise available to you or your Subcontractor in the event of a dispute involving late payment or nonpayment by you, deficient subcontract performance, or noncompliance by a Subcontractor.

**K. CERTIFICATION.**

1. The City accepts certifications of DBE, DVBE, MBE, SMBE, SWBE, or WBE by any of the following certifying agencies:
  - a) Current certification by the State of California Department of Transportation (CALTRANS) as DBE, SMBE, or SWBE.
  - b) Current MBE, WBE, or DVBE certification from the California Public Utilities Commission.
  - c) DVBE certification is received from the State of California's Department of General Services, Office of Small and Minority Business.
  - d) Current certification by the City of Los Angeles as DBE, WBE, or MBE.
  - e) Subcontractors' valid proof of certification status (copies of MBE, WBE, DBE, or DVBE certifications) shall be submitted as required.

**L. CONTRACT RECORDS AND REPORTS.**

1. You shall maintain records of all subcontracts and invoices from your Subcontractors and Suppliers for work on this project. Records shall show

name, telephone number including area code, and business address of each Subcontractor, Supplier, and joint venture partner, and the total amount actually paid to each firm. Project relevant records, regardless of tier, may be periodically reviewed by the City.

2. You shall retain all records, books, papers, and documents pertinent to the Contract for a period of not less than 5 years after Notice of Completion and allow access to said records by the City's authorized representatives.
3. You shall submit the following reports using the City's web-based contract compliance (Prism® portal):
  - a. **Monthly Payment.** You shall submit Monthly Payment Reporting by the 10<sup>th</sup> day of the subsequent month. Incomplete and/or delinquent reporting may cause payment delays, non-payment of invoices, or both.
4. The records maintained under item 1, described above, shall be consolidated into a Final Summary Report, certified as correct by an authorized representative of the Contractor. The Final Summary Report shall include all subcontracting activities and be sent to the EOCP Program Manager prior to Acceptance. Failure to comply may result in assessment of liquidated damages or withholding of retention. The City will review and verify 100% of subcontract participation reported in the Final Summary Report prior to approval and release of final retention to you. In the event your Subcontractors are owed money for completed Work, the City may authorize payment to subcontractor via a joint check from the withheld retention.

**ATTACHMENT D**  
**PREVAILING WAGE**

## PREVAILING WAGE

1. **PREVAILING WAGE RATES:** Pursuant to San Diego Municipal Code section 22.3019, construction, alteration, demolition, repair and maintenance work performed under this Contract is subject to State prevailing wage laws. For construction work performed under this Contract cumulatively exceeding \$25,000 and for alteration, demolition, repair and maintenance work performed under this Contract cumulatively exceeding \$15,000, the Contractor and its subcontractors shall comply with State prevailing wage laws including, but not limited to, the requirements listed below.
  - 1.1. **Compliance with Prevailing Wage Requirements.** Pursuant to sections 1720 through 1861 of the California Labor Code, the Contractor and its subcontractors shall ensure that all workers who perform work under this Contract are paid not less than the prevailing rate of per diem wages as determined by the Director of the California Department of Industrial Relations (DIR). This includes work performed during the design and preconstruction phases of construction including, but not limited to, inspection and land surveying work.
    - 1.1.1. Copies of such prevailing rate of per diem wages are on file at the City and are available for inspection to any interested party on request. Copies of the prevailing rate of per diem wages also may be found at <http://www.dir.ca.gov/OPRL/DPreWageDetermination.htm>. Contractor and its subcontractors shall post a copy of the prevailing rate of per diem wages determination at each job site and shall make them available to any interested party upon request.
    - 1.1.2. The wage rates determined by the DIR refer to expiration dates. If the published wage rate does not refer to a predetermined wage rate to be paid after the expiration date, then the published rate of wage shall be in effect for the life of this Contract. If the published wage rate refers to a predetermined wage rate to become effective upon expiration of the published wage rate and the predetermined wage rate is on file with the DIR, such predetermined wage rate shall become effective on the date following the expiration date and shall apply to this Contract in the same manner as if it had been published in said publication. If the predetermined wage rate refers to one or more additional expiration dates with additional predetermined wage rates, which expiration dates occur during the life of this Contract, each successive predetermined wage rate shall apply to this Contract on the date following the expiration date of the previous wage rate. If the last of such predetermined wage rates expires during the life of this Contract, such wage rate shall apply to the balance of the Contract.
  - 1.2. **Penalties for Violations.** Contractor and its subcontractors shall comply with California Labor Code section 1775 in the event a worker is paid less than the prevailing wage rate for the work or craft in which the worker is employed. This shall be in addition to any other applicable penalties allowed under Labor Code sections 1720 – 1861.

- 1.3. Payroll Records.** Contractor and its subcontractors shall comply with California Labor Code section 1776, which generally requires keeping accurate payroll records, verifying and certifying payroll records, and making them available for inspection. Contractor shall require its subcontractors to also comply with section 1776. Contractor and its subcontractors shall submit weekly certified payroll records online via the City's web-based Labor Compliance Program. Contractor is responsible for ensuring its subcontractors submit certified payroll records to the City.
- 1.3.1.** Contractor and their subcontractors shall also furnish records specified in Labor Code section 1776 directly to the Labor Commissioner in the manner required by Labor Code section 1771.4.
- 1.4. Apprentices.** Contractor and its subcontractors shall comply with California Labor Code sections 1777.5, 1777.6 and 1777.7 concerning the employment and wages of apprentices. Contractor is held responsible for the compliance of their subcontractors with sections 1777.5, 1777.6 and 1777.7.
- 1.5. Working Hours.** Contractor and their subcontractors shall comply with California Labor Code sections 1810 through 1815, including but not limited to: (i) restrict working hours on public works contracts to eight hours a day and forty hours a week, unless all hours worked in excess of 8 hours per day are compensated at not less than 1½ times the basic rate of pay; and (ii) specify penalties to be imposed on contractors and subcontractors of \$25 per worker per day for each day the worker works more than 8 hours per day and 40 hours per week in violation of California Labor Code sections 1810 through 1815.
- 1.6. Required Provisions for Subcontracts.** Contractor shall include at a minimum a copy of the following provisions in any contract they enter into with a subcontractor: California Labor Code sections 1771, 1771.1, 1775, 1776, 1777.5, 1810, 1813, 1815, 1860 and 1861.
- 1.7. Labor Code Section 1861 Certification.** Contractor in accordance with California Labor Code section 3700 is required to secure the payment of compensation of its employees and by signing this Contract, Contractor certifies that "I am aware of the provisions of Section 3700 of the California Labor Code which require every employer to be insured against liability for workers' compensation or to undertake self-insurance in accordance with the provisions of that code, and I will comply with such provisions before commencing the performance of the work of this Contract."
- 1.8. Labor Compliance Program.** The City has its own Labor Compliance Program authorized in August 2011 by the DIR. The City will withhold contract payments when payroll records are delinquent or deemed inadequate by the City or other governmental entity, or it has been established after an investigation by the City or other governmental entity that underpayment(s) have occurred. For questions or assistance, please contact the City of San Diego's Prevailing Wage Unit at [PWDPprevailingWage@sandiego.gov](mailto:PWDPprevailingWage@sandiego.gov).

- 1.9. Contractor and Subcontractor Registration Requirements.** This project is subject to compliance monitoring and enforcement by the DIR. A contractor or subcontractor shall not be qualified to bid on, be listed in a bid or proposal, subject to the requirements of section 4104 of the Public Contract Code, or engage in the performance of any contract for public work, unless currently registered and qualified to perform public work pursuant to Labor Code section 1725.5. It is not a violation of this section for an unregistered contractor to submit a bid that is authorized by Section 7029.1 of the Business and Professions code or by Section 10164 or 20103.5 of the Public Contract Code, provided the contractor is registered to perform public work pursuant to Section 1725.5 at the time the contract is awarded.
- 1.9.1.** A Contractor's inadvertent error in listing a subcontractor who is not registered pursuant to Labor Code section 1725.5 in response to a solicitation shall not be grounds for filing a bid protest or grounds for considering the bid non-responsive provided that any of the following apply: (1) the subcontractor is registered prior to bid opening; (2) within twenty-four hours after the bid opening, the subcontractor is registered and has paid the penalty registration fee specified in Labor Code section 1725.5; or (3) the subcontractor is replaced by another registered subcontractor pursuant to Public Contract Code section 4107.
- 1.9.2.** By submitting a bid or proposal to the City, Contractor is certifying that he or she has verified that all subcontractors used on this public work project are registered with the DIR in compliance with Labor Code sections 1771.1 and 1725.5, and Contractor shall provide proof of registration for themselves and all listed subcontractors to the City at the time of bid or proposal due date or upon request.
- 1.10. Stop Order.** For Contractor or its subcontractors engaging in the performance of any public work contract without having been registered in violation of Labor Code sections 1725.5 or 1771.1, the Labor Commissioner shall issue and serve a stop order prohibiting the use of the unregistered contractors or unregistered subcontractor(s) on ALL public works until the unregistered contractor or unregistered subcontractor(s) is registered. Failure to observe a stop order is a misdemeanor.
- 1.11. List of all Subcontractors.** The Contractor shall provide the list of subcontractors (regardless of tier), along with their DIR registration numbers, utilized on this Contract prior to any work being performed; and the Contractor shall provide a complete list of all subcontractors with each invoice. Additionally, Contractor shall provide the City with a complete list of all subcontractors (regardless of tier) utilized on this contract within ten working days of the completion of the contract, along with their DIR registration numbers. The City shall withhold final payment to Construction Management Professional until at least thirty (30) days after this information is provided to the City.

**1.12. Exemptions for Small Projects.** There are limited exemptions for installation, alteration, demolition, or repair work done on projects of \$25,000 or less. The Contractor shall still comply with Labor Code sections 1720 et. seq. The only recognized exemptions are listed below:

**1.12.1.** Registration. The Contractor will not be required to register with the DIR for small projects. (Labor Code section 1771.1).

**1.12.2.** Certified Payroll Records. The records required in Labor Code section 1776 shall be required to be kept and submitted to the City of San Diego, but will not be required to be submitted online with the DIR directly. The Contractor will need to keep those records for at least three years following the completion of the Contract. (Labor Code section 1771.4).

**1.12.3.** List of all Subcontractors. The Contractor shall not be required to hire only registered subcontractors and is exempt from submitting the list of all subcontractors that is required in section 1.11. above. (Labor code section 1773.3).

**ATTACHMENT E**  
**SUPPLEMENTARY SPECIAL PROVISIONS**

## SUPPLEMENTARY SPECIAL PROVISIONS

The following Supplementary Special Provisions (SSP) modifies the following documents:

1. The **2021 Edition** of the Standard Specifications for Public Works Construction (The "GREENBOOK").
2. The **2021 Edition** of the City of San Diego Standard Specifications for Public Works Construction (The "WHITEBOOK"), including the following:
  - a) General Provisions (A) for all Construction Contracts.

---

### SECTION 1 – GENERAL, TERMS, DEFINITIONS, ABBREVIATIONS, UNITS OF MEASURE, AND SYMBOLS

**1-2 TERMS AND DEFINITIONS.** To the "WHITEBOOK":

To item 47, "Holiday", ADD the following:

<b>Holiday</b>	<b>Observed On</b>
Juneteenth	June 19

To item 55, "Normal Working Hours", DELETE in its entirety and SUBSTITUTE with the following:

**Normal Working Hours:** Normal Working Hours shall be **9:00 AM to 5:00 PM, Monday through Friday**, inclusive. Saturdays, Sundays, and City Holidays are excluded. Unless otherwise specified on the Traffic Control Permits. No work shall be allowed on the day of the La Jolla Half Marathon, May 16, 2026, Law Enforcement Torch Run for Special Olympics, Date TBD, CAF (Challenged Athletes Foundation) Community Challenge Weekend, Date TBD and Bike Multiple Sclerosis (MS), Bay to Bay, Date TBD.

### SECTION 3 – CONTROL OF THE WORK

**3-2 SELF-PERFORMANCE.** To the "GREENBOOK", DELETE in its entirety and SUBSTITUTE with the following:

1. You shall perform, with your own organization, Contract Work amounting to at least **30%** of the Base Bid.

**3-4 AUTHORITY OF THE BOARD AND THE ENGINEER.** To the "WHITEBOOK", ADD the following:

4. See **Appendix I, Sample Contractor Performance Evaluation (CPE) Form.**

**3-7.6.1 Use of Computer Aided Drafting and Design.** To the "WHITEBOOK", Item 1, DELETE in its entirety and SUBSTITUTE the following:

1. Use AUTOCAD for the preparation of Plans and As-Built drawings in accordance with the City's CADD Standards.

**3-9 TECHNICAL STUDIES AND SUBSURFACE DATA.** To the "WHITEBOOK", ADD the following:

5. In preparation of the Contract Documents, the designer has relied upon the following reports of explorations and tests at the Work Site:
  - a) Torrey Pines Rd. Coastal Walk Subsurface Utility Report dated August 21, 2025 prepared by Underground Solutions Inc. The report is available for review at the following link:  
[https://ecpfiles.sandiego.gov/CIP\\_Contracts/K-26-2448-DBB-3/K-26-2448-DBB-3%20Original%20Solicitation%20Documents.zip](https://ecpfiles.sandiego.gov/CIP_Contracts/K-26-2448-DBB-3/K-26-2448-DBB-3%20Original%20Solicitation%20Documents.zip)
  - b) Pavement Coring for Torrey Pines Road Guardrail Memorandum, dated September 4, 2025, prepared by City of San Diego, Construction Engineering Support. See **Appendix F**.

#### **SECTION 4 - CONTROL OF MATERIALS**

**4-6 TRADE NAMES.** To the "WHITEBOOK", ADD the following:

11. You shall submit your list of proposed substitutions for an "equal" item **no later than 5 Working Days after the issuance of the Notice of Intent to Award** and on the City's Product Submittal Form available at:

<https://www.sandiego.gov/ecp/edocref/>

**5-4 INSURANCE.** To the "GREENBOOK", DELETE in its entirety and SUBSTITUTE with the following:

**5-4 INSURANCE.**

1. The insurance provisions herein shall not be construed to limit your indemnity and defense duties set forth in the Contract.

**5-4.1 Policies and Procedures.**

1. You shall procure the insurance described below, at your sole cost and expense, to provide coverage against claims for loss including injuries to persons or damage to property, which may arise out of or in connection with the performance of the Work by you, your agents, representatives, officers, employees or Subcontractors.

2. Insurance coverage for property damage resulting from your operations is on a replacement cost valuation. The market value will not be accepted.
3. You shall maintain this insurance as required by this Contract and at all times thereafter when you are correcting, removing, or replacing Work in accordance with this Contract. Your duties under the Contract, including your indemnity obligations, are not limited to the insurance coverage required by this Contract.
4. If you maintain broader coverage or higher limits than the minimums shown below, City requires and shall be entitled to the broader coverage or the higher limits maintained by you. Any available insurance proceeds in excess of the specified minimum limits of insurance and coverage shall be available to City.
5. Your payment for insurance shall be included in the Contract Price you bid. You are not entitled to any additional payment from the City to cover your insurance, unless the City specifically agrees to payment in writing. Do not begin any Work under this Contract or allow any Subcontractors to begin work, until you have provided, and the City has approved, all required insurance.
6. Policies of insurance shall provide that the City is entitled to 30 days advance written notice of cancellation or non-renewal of the policy or 10 days advance written notice for cancellation due to non-payment of premium. Maintenance of specified insurance coverage is a material element of the Contract. Your failure to maintain or renew coverage and to provide evidence of renewal during the term of the Contract may be treated by the City as a material breach of the Contract.

## **5-4.2 Types of Insurance.**

### **5-4.2.1 General Liability Insurance.**

1. Commercial General Liability Insurance shall be written on the current version of the ISO Occurrence form CG 00 01 07 98 or an equivalent form providing coverage at least as broad.
2. The policy shall cover liability arising from premises and operations, XCU (explosions, underground, and collapse), independent contractors, products/completed operations, personal injury and advertising injury, bodily injury, property damage, and liability assumed under an insured's contract (including the tort liability of another assumed in a business contract).
3. There shall be no endorsement or modification limiting the scope of coverage for either "insured vs. insured" claims or contractual liability. You shall maintain the same or equivalent insurance for at least 10 years following completion of the Work.
4. All costs of defense shall be outside the policy limits. Policy coverage shall be in liability limits of not less than the following:

<u>General Annual Aggregate Limit</u>	<u>Limits of Liability</u>
Other than Products/Completed Operations	\$10,000,000
Products/Completed Operations Aggregate Limit	\$10,000,000
Personal Injury Limit	\$5,000,000
Each Occurrence	\$5,000,000

**5-4.2.2 Commercial Automobile Liability Insurance.**

1. You shall provide a policy or policies of Commercial Automobile Liability Insurance written on the current version of the ISO form CA 00 01 12 90 or later version or equivalent form providing coverage at least as broad in the amount of \$1,000,000 combined single limit per accident, covering bodily injury and property damage for owned, non-owned, and hired automobiles (“Any Auto”).
2. All costs of defense shall be outside the limits of the policy.

**5-4.2.3 Workers’ Compensation Insurance and Employers Liability Insurance.**

1. In accordance with the provisions of California Labor Code section 3700, you shall provide, at your expense, Workers’ Compensation Insurance and Employers Liability Insurance to protect you against all claims under applicable state workers’ compensation laws. The City, its elected officials, and employees will not be responsible for any claims in law or equity occasioned by your failure to comply with this requirement.
2. Statutory Limits shall be provided for Workers’ Compensation Insurance as required by the state of California, and Employer’s Liability Insurance with limits of no less than \$1,000,000 per accident for bodily injury or disease.
3. By signing and returning the Contract, you certify that you are aware of the provisions of California’s Workers’ Compensation laws, including Labor Code section 3700, which requires every employer to be insured against liability for workers’ compensation or to undertake self-insurance, and that you will comply with these provisions before commencing the Work.

**5-4.2.4 Contractors Pollution Liability Insurance.**

1. You shall procure and maintain at your expense or require your Subcontractor, as described below, to procure and maintain Contractors Pollution Liability Insurance applicable to the Work being performed, with a limit no less than \$2,000,000 per claim or occurrence and \$4,000,000 aggregate per policy period of one year.
2. All costs of defense shall be outside the limits of the policy.
3. You shall obtain written approval from the City for any insurance provided by your Subcontractor instead of you.

4. For approval of a substitution of your Subcontractor's insurance, you shall certify that all activities for which the Contractors Pollution Liability Insurance will provide coverage will be performed exclusively by the Subcontractor providing the insurance. The deductible shall not exceed \$25,000 per claim unless the City has provided prior, written approval.
5. Occurrence based policies shall be procured before the Work commences. Claims Made policies shall be procured before the Work commences, shall be maintained for the Contract Time, and shall include a 12-month extended Claims Discovery Period applicable to this contract or the existing policy or policies that shall continue to be maintained for 12 months after the completion of the Work without advancing the retroactive date.

**5-4.3 Rating Requirements.** Except for the State Compensation Insurance Fund, all insurance required by this Contract shall be carried only by responsible insurance companies with a rating of, or equivalent to, at least "A-, VI" by A.M. Best Company, that are authorized by the California Insurance Commissioner to do business in the state of California, and that have been approved by the City.

**5-4.3.1 Non-Admitted Carriers.** The City will accept insurance provided by non-admitted, "surplus lines" carriers only if the carrier is authorized to do business in the state of California and is included on the List of Approved Surplus Lines Insurers (LASLI list).

All policies of insurance carried by non-admitted carriers shall be subject to all of the requirements for policies of insurance provided by admitted carriers described in this Contract.

**5-4.4 Evidence of Insurance.** You shall furnish the City with original Certificates of Insurance, including all required amendatory endorsements (or copies of the applicable policy language effecting coverage required by this clause), prior to your commencement of Work under this Contract. In addition, The City reserves the right to require complete, certified copies of all required insurance policies, including endorsements, required by these specifications, at any time.

**5-4.5 Policy Endorsements.**

**5-4.5.1 Commercial General Liability Insurance.**

**5-4.5.1.1 Additional Insured.** To the fullest extent permitted by law and consistent with the limiting provisions set forth at California Civil Code section 2782, California Insurance Code section 11580.04, and any applicable successor statutes limiting indemnification of public agencies that bind the City, the policy or policies shall be endorsed to include as an Additional Insured the City and its respective elected officials, officers, employees, agents, and representatives, with respect to liability arising out of:

1. Ongoing operations performed by you or on your behalf,
2. your products,

3. your work, e.g., your completed operations performed by you on your behalf, or
4. premises owned, leased, controlled, or used by you.

**5-4.5.1.2 Primary and Non-Contributory Coverage.** The policy shall be endorsed to provide that the coverage with respect to operations, including the completed operations, if appropriate, of the Named Insured is primary to any insurance or self-insurance of the City and its elected officials, officers, employees, agents and representatives. Further, it shall provide that any insurance maintained by the City and its elected officials, officers, employees, agents and representatives shall be in excess of your insurance and shall not contribute to it.

**5-4.5.1.3 Project General Aggregate Limit.** The policy or policies shall be endorsed to provide a Designated Construction Project General Aggregate Limit that will apply only to the Work. Only claims payments which arise from the Work shall reduce the Designated Construction Project General Aggregate Limit. The Designated Construction Project General Aggregate Limit shall be in addition to the aggregate limit provided for the products-completed operations hazard.

**5-4.5.2 Workers' Compensation Insurance and Employers Liability Insurance.**

**5-4.5.2.1 Waiver of Subrogation.** The policy or policies shall be endorsed to provide that the insurer will waive all rights of subrogation against the City and its respective elected officials, officers, employees, agents, and representatives for losses paid under the terms of the policy or policies and which arise from Work performed by the Named Insured for the City.

**5-4.5.3 Contractors Pollution Liability Insurance Endorsements.**

**5-4.5.3.1 Additional Insured.** To the fullest extent permitted by law and consistent with the limiting provisions set forth at California Civil Code section 2782, California Insurance Code section 11580.04, and any applicable successor statutes limiting indemnification of public agencies that bind the City, the policy or policies shall be endorsed to include as an Additional Insured the City and its respective elected officials, officers, employees, agents, and representatives, with respect to liability arising out of:

1. Ongoing operations performed by you or on your behalf,
2. your products,
3. your work, e.g., your completed operations performed by you on your behalf, or
4. premises owned, leased, controlled, or used by you.

**5-4.5.3.2 Primary and Non-Contributory Coverage.** The policy or policies shall be endorsed to provide that the insurance afforded by the Contractors Pollution Liability Insurance policy or policies is primary to any insurance or self-insurance of the City and its

elected officials, officers, employees, agents and representatives with respect to operations including the completed operations of the Named Insured. Any insurance maintained by the City and its elected officials, officers, employees, agents and representatives shall be in excess of your insurance and shall not contribute to it.

**5-4.5.3.3 Severability of Interest.** For Contractors Pollution Liability Insurance, the policy or policies shall provide that your insurance shall apply separately to each insured against whom claim is made or suit is brought, except with respect to the limits of the insurer's liability and shall provide cross-liability coverage.

**5-4.6 Deductibles and Self-Insured Retentions.** You shall disclose deductibles and self-insured retentions to the City at the time the evidence of insurance is provided. The City may require you to purchase coverage with a lower retention or provide proof of ability to pay losses and related investigations, claim administration, and defense expenses within the retention. The policy language shall provide, or be endorsed to provide, that the self-insured retention may be satisfied by either the named insured or City.

**5-4.7 Reservation of Rights.** The City reserves the right, from time to time, to review your insurance coverage, limits, deductibles, and self-insured retentions to determine if they are acceptable to the City. The City will reimburse you, without overhead, profit, or any other markup, for the cost of additional premium for any coverage requested by the Engineer, but not required by this Contract.

**5-4.8 Notice of Changes to Insurance.** You shall notify the City, in writing, 30 days prior to any material change to the policies of insurance provided under this Contract. This written notice is in addition to the requirements of paragraph 6 of Section 5-4.1.

**5-4.9 Excess Insurance.** Policies providing excess coverage shall follow the form of the primary policy or policies, including, all endorsements.

**5-10.2.1 Public Notice by Contractor.** To the "WHITEBOOK", DELETE in its entirety and SUBSTITUTE with the following:

**5-10.2.1 Public Notice by Contractor.**

1. Post Project Identification Signs in accordance with 3-11.2, "Project Identification Signs".
2. No less than 5 and no more than 10 Working Days in advance of Project construction activities and utility service interruptions, you shall notify all critical facilities, businesses, institutions, property owners, residents, or any other impacted stakeholders within a minimum 300-foot (90 m) radius of the Project i.e., work area and any other affected areas as shown on the "Notification of Planned Water Shutdown" when you perform the Work.

3. The notification process must be repeated for delays and long pauses in construction activities. Verbal and written notifications, such as door hangers, shall be sent to critical facilities (including but not limited to police stations, fire stations, hospitals, and schools). A copy of written notifications sent to any critical facility shall also be sent to the Engineer.
4. You shall keep records of the people contacted, along with the dates of notification, and shall provide the record e.g., time-stamped pictures of the notices, to the Engineer upon request. You shall identify all other critical facilities that need to be notified.
5. Verbal and written notifications shall also include specific impacts from the construction of the City facilities, e.g., fire hydrants, air vacuum and blow-off devices, pedestrian ramps, and sidewalks, e.g., the loss of parking, access, and impact to private property, e.g., landscaping.
6. Furnish and distribute public notices in the form of door hangers using the City's format to all occupants and/or property owners along streets and all critical facilities such as police stations, fire stations, hospitals, and schools.
7. Where Work is to be performed at least 5 and at most 10 Working Days before starting construction, survey activities, or impacting the community as approved by the Engineer.
8. Within 5 Working Days of the completion or pausing of your construction activities where Work was performed, you shall distribute public notices in the form of door hangers, which outline the anticipated dates of Asphalt Resurfacing, Slurry Seal, Sidewalk, or Curb Ramp Work. Upon resuming construction activities, you shall redistribute door hangers.
9. "No Parking" signs shall be placed 72 hours before the scheduled construction activities and must include the name and phone number of the Contractor. The Contractor shall document the placement of the signs with time-stamped pictures.
10. Leave the door hanger notices on or at the front door of each dwelling and apartment unit and at each commercial building tenant abutting each street block segment.
11. Where the front doors of apartment units are inaccessible or occupants are unavailable, distribute the door hanger notices to the apartment manager or security officer and leave your contact information, such as business cards.
12. Provide time-stamped pictures of the notices to the Engineer.
13. Door Hanger Material: You shall use Blanks/USA brand, Item Number DHJ5B6WH, 1¼ inch (31.8 mm) Holes (removed), 2-up Jumbo Door Hanger in Bristol White, or approved equal.
14. Door hangers shall include the funding source if project is funded in part by State Gas Tax Revenue (SB1).

15. Mailed Notice Material: You shall use Cougar by Domtar, Item Number 2834, or approved equal.
16. For all Work on private property, contact each owner and occupant individually a minimum of 15 Working Days before the Work. If the Work has been delayed, re-notify owners and occupants of the new Work schedule, as directed by the Engineer.
17. A sample of public notices will be included in the Contract.
  - a) See **Appendix G – Sample of Public Notice.**

**SECTION 6 – PROSECUTION AND PROGRESS OF THE WORK**

**6-1.1 Construction Schedule.** To the “WHITEBOOK”, ADD the following:

3. Refer to the Sample City Invoice in **Appendix D – Sample City Invoice** and use the format shown.

**ADD:  
6-6.1.1**

**Environmental Document.**

1. The City of San Diego has prepared a **Notice of Exemption for Torrey Pines Road, Prospect-Coast Walk Guardrail**, Project No. **B-19056.02.06**, as referenced in the Contract Appendix. You shall comply with all requirements of the **Notice of Exemption** as set forth in **Appendix A.**
2. Compliance with the City’s environmental document shall be included in the Contract Price, unless separate bid items have been provided.

**6-9 LIQUIDATED DAMAGES.** To the “WHITEBOOK”, item 2, DELETE in its entirety and SUBSTITUTE with the following:

2. The execution of the Contract shall constitute agreement between you and the City that the liquidated damage amount described in the table below is the value of the damage caused by your failure to complete the Work within the allotted time. Such sum shall not be construed as a penalty and may be deducted from your payments if such delay occurs.

<b>Contract Value</b>	<b>Liquidated Damages Daily Amount</b>
Less than \$200,001	\$1,000
\$200,001 to \$500,000	\$1,500
\$500,001 to \$1,000,000	\$2,000
\$1,000,001 to \$2,000,000	\$2,500

<b>Contract Value</b>	<b>Liquidated Damages Daily Amount</b>
\$2,000,001 to \$5,000,000	\$3,000
\$5,000,001 to \$10,000,000	\$5,500
\$10,000,001 to \$20,000,000	\$6,500
Greater Than \$20,000,000	\$7,000

**SECTION 7 - MEASUREMENT AND PAYMENT**

**7-3.2.2.1 Progress Payment for Pipelines.** To the "WHITEBOOK", item 4, DELETE in its entirety and SUBSTITUTE with the following:

- In asphalt-surfaced streets, the City shall pay 15% for hydrostatic and bacterial testing, Wayneball and Mandrelling (where necessary), for water and sewer utility constructions respectively, and operational testing for storm drains, including the trench cap and cleanup. The City shall pay the remaining 5% after completing the asphalt wearing surface, Trench Capping per SDG-107 "Pavement Restoration for Asphalt Concrete Surfaced Streets - Major Excavation", and final cleanup.

**7-3.9 Field Orders.** To the "WHITEBOOK", DELETE in its entirety and SUBSTITUTE with the following:

- If the cumulative total of Field Order items of Work does not exceed the "**Field Orders**" Bid Item, the City shall pay those Field Orders as shown below:

**TABLE 7-3.9  
FIELD ORDER LIMITS**

<b>Contract Price</b>	<b>Maximum Each Field Order Work Amount</b>
Less than \$1,000,001	\$10,000
\$1,000,001 to \$5,000,000	\$20,000
\$5,000,001 to \$10,000,000	\$25,000
\$10,000,001 to \$30,000,000	\$40,000
Greater than \$30,000,000	\$70,000

**7-3.11 Compensation Adjustments for Price Index Fluctuations.** To the "WHITEBOOK", ADD the following:

5. This Contract **is not** subject to the provisions of The "WHITEBOOK" for Compensation Adjustments for Price Index Fluctuations for paving asphalt.

### **SECTION 203 - BITUMINOUS MATERIALS**

**203-6.1 General.** To the "WHITEBOOK" and "GREENBOOK", DELETE in its entirety and SUBSTITUTE with the following:

**203-6.1 General.** Asphalt concrete shall be the product of mixing mineral aggregate and reclaimed asphalt pavement (RAP) with asphalt binder at a central mixing plant.

When specified in the Special Provisions, asphalt concrete may be produced using a warm mix asphalt (WMA) technology.

Unless otherwise specified in the Special Provisions or shown on the Plans, asphalt concrete mixtures shall conform to 203-6.4.

If the asphalt concrete mixture contains more than 15% RAP, refer to Caltrans Standard Specifications Section 39, "Asphalt Concrete" for "Materials" and "Construction" requirements only unless specified otherwise in these (1) Supplementary Special Provisions, (2) The WHITEBOOK, and (3) The GREENBOOK in that order of precedence. Replace all references to actions by the "Department" with actions by the "City."

**203-6.2.1 Asphalt Binder.** To the "GREENBOOK", ADD the following:

Unless otherwise specified, for mixtures containing 15 percent or less RAP, the performance grade of the virgin asphalt binder shall be the grade specified in the Special Provisions with the upper and lower temperature classification of Performance Grade (PG) 64-10.

For mixtures containing greater than 15 percent and not exceeding 25 percent RAP, the performance grade of the virgin binder shall be the grade specified in the Special Provisions with the upper and lower temperature classification of PG 58-16.

For mixtures containing greater than 25 percent RAP, the performance grade of the asphalt binder shall be determined based on viscosity and blending charts developed in accordance with AASHTO M323.

**203-6.2.2 Rock Products for Asphalt Concrete Mixtures.** To the "GREENBOOK", ADD the following:

Aggregates must be clean and free from deleterious substances. The aggregates for a leveling course must comply with the gradation specifications for Type A HMA in Caltrans Standard Specification Section 39-2.02B.

**203-6.2.3 Rock Products for Type III Asphalt Concrete Mixtures.** To the "GREENBOOK", ADD the following:

Aggregate gradation must be determined before the addition of asphalt binder and must include supplemental fine aggregates. Test for aggregate gradation under AASHTO T 27. Do not wash the coarse aggregate. Wash the fine aggregate only. Use a mechanical sieve shaker. Aggregate shaking time must not exceed 10 minutes for each coarse and fine aggregate portion. Choose a TV within the TV limits shown in the tables titled "Aggregate Gradations." Gradations are based on nominal maximum aggregate size.

**203-6.2.5.1 General.** To the "GREENBOOK", ADD the following:

RAP shall be defined as asphalt concrete pavement that has been processed to a maximum of 1 inch (25 mm) in size and is free of contaminants. RAP may be substituted for part of the virgin aggregate in a quantity up to the lowest level allowed in the Caltrans Standard Specifications by dry weight of the combined aggregates.

Unless otherwise specified, RAP may be substituted for part of the virgin aggregate at or above the level allowed in the Caltrans Standard Specifications; currently, 25 percent by dry weight of the combined aggregates.

**203-6.2.5.2 RAP Stockpiles.** To the "GREENBOOK", ADD the following:

Fractionated RAP stockpiles shall be isolated from other materials. Fractionated RAP shall be stored in conical or longitudinal stockpiles. Fractionated RAP shall not be agglomerated or be allowed to congeal.

**203-6.2.5.3 Fractionation.** To the "GREENBOOK". DELETE in its entirety and SUBSTITUTE with the following:

**203-6.2.5.3 Fractionation.** Fractionation is the processing of RAP into 2 or more sizes. For RAP substitution of 15 percent or less, fractionation is not required. For RAP substitution greater than 15 percent, RAP shall be fractionated into 2 sizes conforming to the requirements shown in Table 203-6.2.5.3. The RAP stockpile fractionation gradation shall conform to the requirements shown in Table 203-6.2.5.3.

**Table 203-6.2.5.3**

<b>Size</b>	<b>Test Method</b>	<b>Requirement</b>
Coarse (% passing the 1-inch sieve)	California Test 202 <sup>a</sup>	100
Fine (% passing the 3/8-inch sieve)	California Test 202 <sup>a</sup>	98-100

<sup>a</sup> Maximum mechanical shaking time is 10 minutes.

If RAP is from multiple sources, the RAP shall be thoroughly and completely blended before fractionating.

The coarse fractionated stockpile, the fine fractionated stockpile, or a combination of the coarse and fine fractionated stockpile may be used.

**203-6.2.5.4 Testing.** To the "GREENBOOK", ADD the following:

The mix design RAP stockpile shall be sampled and tested in accordance with California Test 384. The average shall be reported on the mix design submittal. When the mix design RAP stockpile is augmented, RAP used to augment the stockpile shall be sampled at a minimum frequency of 1 sample per 500 tons in accordance with California Test 384 before augmenting. Each sample shall be tested to determine the uncorrected binder content in accordance with AASHTO T 308. The same ignition oven shall determine the uncorrected asphalt binder content reported on the mix design submittal.

The augmented RAP sample, when tested under AASHTO T 209, shall be within  $\pm 0.06$  of the average maximum specific gravity reported on the mix design submittal.

For startup of a project:

1. Less than 5,000 tons of a QC test from another City approved submittal from the same plant within the last 90 days may be submitted for review.
2. For greater than 5,000 tons the following QC test must be completed and submitted to the Engineer:

<b>Quality Characteristic</b>	<b>Test Method</b>
Asphalt binder content	AASHTO T 308, Method A
HMA moisture content	AASHTO T 329
Combined Aggregate Gradation	California Test 384
Combined Aggregate Sand equivalent	California Test 217 or ASTM D2419
Combined Aggregate Moisture content	AASHTO T 255
Air voids content	AASHTO T 269
Voids in mineral aggregate	MS-2 Asphalt mixture volumetrics
Dust proportion	MS-2 Asphalt mixture volumetrics
Hveem Stability	MS-2 and OBC CT 367

Quality Characteristic	Test Method
Hamburg wheel track	AASHTO T 324 (modified)
Gyrations Compaction	AASHTO T 312

During production, RAP QC testing shall be sampled twice daily and the following additional tests shall be performed with the minimum frequency:

Quality Characteristic	Test Method	Minimum Frequency
Asphalt binder content	AASHTO T 308, Method A	1 per day with a minimum of 500 tons
Aggregate Gradation - combined with RAP	California Test 384	1 per day with a minimum of 100 tons
Aggregate Sand equivalency	California Test 217 or ASTM D2419	1 per day with a minimum of 100 tons
Aggregate Moisture content	AASHTO T 255	1 per day with a minimum of 100 tons
Hveem Stability	MS-2 and OBC CT 367	1 per day with a minimum of 100 tons
Hamburg wheel track	AASHTO T 324 (modified)	1 per 5,000 tons or 1 per project, whichever is greater
Nuclear gauge density	California Test 375	1 per 50 tons

**203-6.2.5.5 Quality.** To the "GREENBOOK", ADD the following:

For RAP content higher than 15% in HMA, refer to Sections 39-2.01, "General"; 39-2.02, "Type A Hot Mix Asphalt," and 39-2.03, "Rubberized Hot Mix Asphalt--Gap Graded," of the Caltrans Standard Specifications in effect at the time of Bid for the quality assurance requirements. Under this process, the contractor performs quality control testing, and the City performs acceptance testing and inspection. The acceptance decision is based on the City's test results only.

RAP shall conform to the requirements shown in Table 203-6.2.5.5:

**Table 203-6.2.5.5**

Quality Characteristic	Test method	Requirement
Uncorrected Binder Content (% within the average value reported) <sup>a</sup>	AASHTO T 308	±2.00
Specific gravity (within the average value reported) <sup>b</sup>	AASHTO T 209	±0.06

Quality Characteristic	Test method	Requirement
Combined Aggregates Sand Equivalent (min)	California Test 217 or ASTM D2419	50

<sup>a</sup> Average uncorrected binder content of 3 ignition oven tests performed.

<sup>b</sup> Average maximum specific gravity reported on the JMF.

**203-6.3.1 General.** To the "GREENBOOK" and "WHITEBOOK", DELETE in its entirety and SUBSTITUTE with the following:

**203-6.3.1 General.**

1. The Contractor shall submit in accordance with 3-8.4 a JMF that summarizes each asphalt concrete mix design for each class and grade of asphalt concrete required to construct the Work. Supporting information for the warm mix asphalt (WMA) technology and/or recycling agent, if included in a mixture, shall also be submitted e.g., C2 PG 58-16 (½ inch) (12.5 mm) and B3 PG 58-16 (¾ inch) (19 mm) asphalt concrete.
2. Asphalt concrete for JMF and Mix Designs shall be Type III and shall not exceed the allowable RAP level.
3. The JMF shall identify the source and the individual grading of each material used to produce the mix design (including the percentage and individual gradation of any manufactured or natural sands), the combined gradation, the optimum binder content (OBC), void content, reclaimed asphalt pavement (RAP) percentage, RAP gradation, RAP binder content, stability value, plant identification, mix number, WMA technology, and the source and performance grade of the paving asphalt. Upon request, the mix design test data represented by the JMF shall be immediately made available to the Engineer.
4. When greater than 25 percent RAP is to be included in a mixture, a mix design shall be submitted on Caltrans Forms CEM-3511 and CEM-3512 or another format as approved by the Engineer. The submittal shall include supporting information showing the viscosity of the individual binders (both the virgin paving asphalt grade and that of the binder recovered from the RAP); and the amount of recycling agent, if any, and the blended final viscosity in accordance with AASHTO M323.
5. For all mixtures, the asphalt binder content shall be defined as the total bituminous material present in the mix consisting of the blend of virgin paving asphalt, residual paving asphalt from RAP, and recycling agent.
6. Refer to Caltrans Standard Specifications, 39-2.01A(3)(b), "Job Mix Formula" for additional requirements for modifications, renewal, authorization, and quality control plan.

7. A new mix design shall be prepared and a new JMF submitted if:
  - a) the combined aggregate gradation is not within  $\pm 3$  percentage points of the gradation shown on the referenced mix design on any sieve,
  - b) the source of any aggregate is changed,
  - c) the performance grade of paving asphalt is changed,
  - d) the average binder content in a new fractionated RAP stockpile varies by more than  $\pm 2.00$  percent from the average RAP binder content reported on the JMF,
  - e) the average maximum specific gravity in a new fractionated RAP stockpile varies by more than  $\pm 0.060$  from the average maximum specific gravity value reported on the JMF.
  
8. AASHTO T 324 (Modified) is AASHTO T 324 (Standard Method of Test for Hamburg Wheel-Track Testing of Compacted Asphalt Mixtures) with the following parameters:
  - a) Target air voids must equal  $7.0 \pm 1.0$  percent.
  - b) Specimen height must be  $60 \pm 1$  mm.
  - c) Number of test specimens must be 4 to run 2 tests.
  - d) Do not average the 2 test results.
  - e) Test specimen must be a 150 mm gyratory compacted specimen.
  - f) Test temperature must be set at:
    1.  $113 \pm 2$  degrees F for PG 58 for use of 25% RAP
    2.  $122 \pm 2$  degrees F for PG 64 for use of 15% RAP
    3. Measurements for impression must be taken at every 100 passes along the total length of the sample.
  - g) Inflection point is the number of wheel passes at the intersection of the creep slope and the stripping slope at maximum rut depth.
  - h) Testing shut off must be set at 25,000 passes.
  - i) Submersion time for samples must not exceed 4 hours.
  
9. Take samples under California Test 125.

**ADD:**

**203-6.3.3**

**Asphalt Binder Replacement.** Asphalt binder replacement shall be defined as the asphalt binder from RAP expressed as a percent of the total asphalt binder in the mixture. The asphalt binder replacement shall be calculated as a percentage of the

approved JMF target asphalt binder content. The maximum asphalt binder replacement for mixtures containing RAP shall be 25 percent of the optimum binder content (OBC) for surface courses and 40 percent for leveling and base courses.

For Type A HMA with a binder replacement percent less than or equal to 25 percent of your specified OBC, you may request that the performance-graded asphalt binder grade with upper and lower temperature classifications be reduced by 6 degrees C from the specified grade.

Once the City has approved a mix design, the asphalt binder content shall be within 0.5% of the identified target binder contents for each mix design submitted.

Each approved asphalt plant and location shall perform an annual verification process with the City.

**ADD:**

**203-6.4.5**

**Miscellaneous Areas and Dikes.** For miscellaneous areas and dikes:

1. Choose the aggregate gradation from:
  - a) 1/2-inch Type A HMA aggregate gradation.
  - b) Dike mix aggregate gradation.
2. Choose asphalt binder Grade PG 58-16 or 64-10.
3. Minimum asphalt binder content must be:
  - a) 5.70 percent for 1/2-inch Type A HMA aggregate gradation.
  - b) 6.00 percent for dike mix aggregate gradation.

If you request and the Engineer authorizes, you may reduce the minimum asphalt binder content. Aggregate gradation for dike mix must be within the TV limits for the specified sieve size as shown below:

Sieve size	Target value limit	Allowable tolerance
1/2"	100	--
3/8"	---	95 - 100
No. 4	73-77	TV ± 10
No. 8	58-63	TV ± 10
No. 30	29-34	TV ± 10
No. 200		0 - 14

For HMA used in miscellaneous areas and dikes, sections 203-6.3.1 do not apply.

**203-6.7**      **Production.** To the "GREENBOOK", ADD the following:

1.      Before production, the HMA plant must have a current qualification under the City's Material Plant Quality Program for each mix design.

**203-6.7.1**      **General.** To the "GREENBOOK", ADD the following:

During production, the hot- or cold-feed proportion controls for virgin aggregate and RAP may be adjusted. For RAP substitution of 15 percent or less, RAP must be within  $\pm 5$  of the RAP percentage shown in the approved JMF form without exceeding 15 percent. For RAP substitution of greater than 15 percent, RAP must be within  $\pm 5$  of the RAP percentage shown in the approved JMF form without exceeding 25 percent.

Do not start HMA production before verification and authorization of JMF. The HMA plant must have a current qualification under the City's Material Plant Quality Program. Weighing and metering devices used to produce HMA modified with additives must comply with the City's MPQP. If a loss-in-weight meter is used for dry HMA additive, the meter must have an automatic and integral material delivery control system for the refill cycle.

Calibrate the loss-in-weight meter by:

1.      Including at least 1 complete system refill cycle during each calibration test run
2.      Operating the device in a normal run mode for 10 minutes immediately before starting the calibration process
3.      Isolating the scale system within the loss-in-weight feeder from surrounding vibration
4.      Checking the scale system within the loss-in-weight feeder for accuracy before and after the calibration process and daily during mix production
5.      Using a minimum 15 minute or minimum 250 lb. test run size for a dry ingredient delivery rate of less than 1 ton per hour
6.      Complying with the limits of City's Conveyor Scale Testing

Proportion aggregate by hot or cold-feed control. The aggregate temperature must not be more than 375 degrees F when mixed with the asphalt binder. Asphalt binder temperature must be from 275 to 375 degrees F when mixed with aggregate. Mix HMA ingredients into a homogeneous mixture of coated aggregates.

HMA must be produced at the temperatures shown in the following table:

HMA compaction	Temperature (°F)
Density based Method	Not to exceed 325

If you stop production for longer than 30 days, a production start-up evaluation is required.

**SECTION 209 – PRESSURE PIPE**

**209-1.1.1 General.** To the “GREENBOOK”, ADD the following:

1. PVC products, specifically type C900 and C905, as manufactured or distributed by J-M Manufacturing Company or JM Eagle shall not be used on the Contract for pressurized pipe.
2. Refer to AWWA C900-16 for all references to AWWA C905.

**209-7.2 Requirements.** To the "GREENBOOK", Table 209-7.2, DELETE in its entirety and SUBSTITUTE with the following:

**TABLE 209-7.2**

Function	Type	Materials/Method	
Pipe Contents Identification	Pipe Color (Plastic Pipe or Polywrap <sup>1</sup> )	Blue for Potable Water. Purple for Recycled Water. Green for Sewage.	
	AND		
	Stenciling	Stenciling marked on pipe in contrasting color to background color of pipe stating: "POTABLE WATER", "CAUTION RECYCLED WATER - DO NOT DRINK" or "CAUTION SEWER" as appropriate.	
		5/8" (16 mm) high letters.	
		Repeated at 1 foot (300 mm) intervals.	
	OR		
Identification Tape	Polyethylene tape 6" (150 mm) wide and 4 mils (100 µm) minimum thickness with 2" (50 mm) high letters stating: "POTABLE WATER", "CAUTION RECYCLED WATER - DO NOT DRINK" or "CAUTION SEWER" as appropriate. For pipe > 12" (300 mm) diameter, use 12" (300 mm) wide tape.		
	Color - Blue With white letters for potable water, Purple With white letters for recycled water, Green with white letters for sewage.		
	Attached to top of pipe with adhesive tape.		
Pipe Warning and Locating	Warning and Locating Tape	Polyethylene tape 6" (150 mm) Wide and 4 mils (100 µm) minimum thickness with 2"(50 mm) high letters stating: "CAUTION: WATERLINE BURIED BELOW", "CAUTION RECLAIMED WATERLINE BURIED BELOW - DO NOT DRINK", or "CAUTION: SEWER BURIED BELOW" as appropriate. For pipe > 12" (300 mm) diameter, use 12" (300 mm) wide tape.	

Function	Type	Materials/Method
		Color - blue with black or white letters for potable water, Purple With black or white letters for recycled water, Green with black or white letters for sewage.
		Place in pipe trench 18" (450 mm) above pipe.
		Tape shall contain metallic strip that can be registered by magnetic field locating device.
		OR
	Locating Wire	In lieu of installing metallic warning tape; non-metallic warning tape 18" (450 mm) above pipe and 10-gauge copper wire attached to top of pipe and accessibly terminated may be used.

<sup>1</sup>Polywrap shall not be used as pipe color identification for plastic pipe.

## SECTION 300 – EARTHWORK

**300-1.1 General** To the “WHITEBOOK”, ADD following:

10. Prior to any demolition and removal, Contractor shall sawcut existing improvements to neat, clean lines as shown on the Contract Documents and shall include, but not limited to, the following items as shown on the Plans or specified in these Special Provisions:
  - a. Removal of existing asphaltic concrete pavement sections, including asphaltic concrete and aggregate base materials (excluding milling for asphalt concrete overlay), and berms. Removal of asphalt paving shall include removal of base and subgrade material to the depth required for new pavement sections.
  - b. Removal of PCC pavement, PCC curb, PCC curb and gutter, PCC sidewalks, PCC curb ramps, including aggregate base material conflicting with the proposed improvements
  - c. Removal of trees, shrubs, stumps, trash, debris barricade, vegetation in the pavement cracks or curb lines, whether or not specifically indicated on the Plans or otherwise shown to be protected or relocated, not included in any other bid item.
  - d. Deleterious materials resulting from Clearing and Grubbing operations shall be hauled away and legally disposed of at a site obtained by the Contractor.
  - e. Removal and disposal of fences, drainage structures, walls, street lights, abandoned utilities, signs/posts, flumes, and any additional items not specifically mentioned which may be found within the work limits.
  - f. Maintenance of project appearance.
  - g. Clean-up of project upon completion of work.
  - h. Clearing tree roots 6” below sidewalk (root pruning), where tree roots are the cause of damage to existing sidewalks or may damage new improvements
  - i. Tree trimming.

- j. Tree protection.
  - k. Removal of existing Concrete K-Rail on-site and delivery to City of San Diego Chollas Operations Yard at 2781 Caminito Chollas San Diego, CA 92105, contact Martin Martinez at (619) 782-4227.
  - l. The demolition, removal, and disposal of all other items in conflict with the improvements not covered under any other bid item.
11. All materials to be removed and disposed of by the Contractor shall become the property of the Contractor. The Contractor has sole discretion on the means of hauling away the removal items and is obligated to dispose of such materials in accordance with all applicable laws, regulations, and ordinances

**SECTION 301 – SUBGRADE PREPARATION, TREATED MATERIALS, AND PLACEMENT OF BASE MATERIALS**

**301-1.2 Preparation of Subgrade** To the “WHITEBOOK”, ADD following:

- 7. Prior to installation of Bridge Rail footing on subgrade, contractor shall confirm subgrade is compacted in accordance with the Standard Specifications, verified by the Resident Engineer, and that subgrade excavation is acceptable to the Engineer.

**301-1.6 Preparatory Repair Work.** To the “WHITEBOOK”, DELETE in its entirety and SUBSTITUTE with the following:

- 1. Prior to the placement of any asphalt concrete or application of slurry, you shall complete all necessary preparation and repair Work and shall obtain approval by the Resident Engineer.
- 2. No preparatory asphalt Work shall be done when the atmospheric temperature is below 50° F (10° C) or during unsuitable weather.
- 3. Preparatory Work shall include tree trimming, weed spray, weed abatement, crack sealing, asphalt repair, cold milling, hump removal, lump removal, subgrade preparation and subgrade or base repair, removal of raised pavement markers, removal of pavement markings, location of public and private utilities and appurtenances, all Concrete works, and all other necessary works as specified in the Special Provisions and Contract Documents or as directed by the Engineer.
- 4. After the completion of the preparatory work, you shall install compacted asphalt concrete pavement according to the thickness specified in the Special Provisions and Contract Documents or a minimum of 2 inches (50.8 mm) for residential streets and a minimum of 3 inches (76.2 mm) for all other streets or as directed by the Engineer.
- 5. You shall identify the location of all utilities vaults, valves, and other appurtenances not included in the project scope requiring relocation or

adjustment to grade by other agencies/companies by marking the face of the curb closest to the utility appurtenance as follows:

1. Offset distance of the appurtenance from the curb face
2. The limits of the appurtenance or corners of the vault/box
6. The quantities shown in the Contract Documents are based on a street assessment survey and may vary. The Engineer will designate the limits to be removed and prepared and these designated areas shall be considered to take precedence over the areas shown in the Contract Documents.
7. You shall repair areas of distressed asphalt concrete pavement by milling or removing damaged areas of pavement to a minimum depth of 2 inches (50.8 mm) for residential streets and a minimum depth of 3 inches (76.2 mm) for all others except where specified otherwise in the Special Provisions and Contract Documents or as directed by the Engineer to expose firm and unyielding pavement as specified.
8. If, in order to achieve the minimum specified depth, the base material or native subgrade is exposed, you shall notify the Engineer the material shall be compacted to 95% relative compaction.
9. Compaction tests shall be made to ensure compliance with the specifications.
10. The QCP shall establish location and timing of compaction testing and shall be subject to approval by the Engineer. You shall reimburse the City for the cost of retesting failing compaction tests conducted as part of the City of San Diego Quality Assurance testing.
11. If additional base material is required, you shall use Class 2 aggregate base in accordance with 200-2.9.1, "Class 2 Aggregate Base (Scheduled, 5 Inch)" and "Class 2 Aggregate Base (Unscheduled, 5 Inch)" or as directed by the Engineer.
12. Prior to placement of compacted asphalt concrete pavement, you shall prepare the subgrade as needed and install a minimum of 2 or 3 inches as specified in the contract documents and special provisions, of compacted asphalt concrete pavement over native material as directed by the Engineer.
13. Areas of damaged asphalt requiring base repair work including excavation, placement of asphalt concrete, asphalt concrete base, and Class 2 aggregate base, have been identified in the Contract Documents as "DO", Dig Out, also called Base Repairs.
14. When applicable, the areas and quantities shown in the Contract Documents are given only for the Contractor's aid in planning the Work and preparing Bids. You shall identify any new areas that require repair prior to paving in order to construct a smooth and stable pavement surface. Upon approval by the engineer, the repair locations shall be incorporated into scope of work and shall not be considered extra work. You shall mark the pavement area as "DO" or as directed by the Engineer.

15. Prior to replacing asphalt, the area shall be cleaned by removing all loose and damaged material, moisture, dirt, and other foreign matter and shall be tack coated in accordance with 302-5.4, "Tack Coat".
16. When milling and/or grinding asphalt pavement for base repair and the contractor encounters level and unyielding PCC trench caps or appurtenance collars before reaching the minimum depth of 2 inches, then the You shall place enough asphalt concrete pavement to bring the surface to be level with the adjacent roadway. Asphalt Concrete Base shall be Type III-B3-PG 64-10 and Asphalt Concrete Pavement shall be Type III-C2-PG 64-10 as directed by the Engineer.
17. You shall install new asphalt within the repair area or for patches in accordance with 302-5, "ASPHALT CONCRETE PAVEMENT". Asphalt concrete shall be Type III-C2-PG 64-10 in compliance with 203-6.3.1, "General".
18. Recycled base material shall conform to Class 2 aggregate Base material in accordance with 200-2.4, "Class 2 Aggregate Base (Scheduled, 5 Inch)" and "Class 2 Aggregate Base (Unscheduled, 5 Inch)".
19. Following the asphalt placement, you shall roll the entire area of new asphalt in both directions at least twice. The finished patch shall be level and smooth in compliance with 302-5.6.2, "Density and Smoothness". After placement and compaction of the asphalt patch, you shall seal all finished edges with a 4 inch (101.6 mm) wide continuous band of SS-1H.
20. Materials removed, regardless of removal method, shall be disposed of at a legal site.
21. The minimum dimensions for each individual repair shall be 4 feet by 4 feet (1.2 m by 1.2 m) and shall be subject to the following conditions:
  - a. If the base material is exposed, to achieve the required minimum removal thickness, the base material shall be prepared conforming to 301-1, "SUBGRADE PREPARATION".
  - b. Base repairs shall have a minimum depth of 10".
  - c. You shall repair the areas shown in the Contract Documents of distressed asphalt concrete to remove damaged areas of pavement in accordance with 404-1, to expose firm and unyielding pavement, base, or native soils, regardless of materials encountered. Unyielding pavement will have no visible cracks and unyielding base, or native soils will be properly compacted, as determined by the Engineer. If cracks are visible, then pavement is not unyielding and shall require additional depth be removed as directed by the Engineer. The Contractor shall prepare subgrade as needed and install a maximum of 5" compacted asphalt concrete pavement over the compacted base material to be level with the adjacent roadway surface.
  - d. When additional base material is required, then you shall use Class 2 aggregate base in accordance with 200-2.4, "Class 2 Aggregate Base

(Scheduled, 5 Inch)" and "Class 2 Aggregate Base (Unscheduled, 5 Inch)" or as directed by the Engineer.

- e. Recycled base material shall conform to Class 2 aggregate base material in accordance with 200-2.4, "Class 2 Aggregate Base (Scheduled, 5 Inch)" and "Class 2 Aggregate Base (Unscheduled, 5 Inch)".
- f. You may use grinding as a method for removal of deteriorated pavement when the areas indicated for removal are large enough (a minimum of the machine drum width) and when approved by the Engineer.
- g. For both scheduled and unscheduled base repairs, failed areas may be removed by milling or by excavation provided that the edges are cut cleanly with a saw. The areas shall be cleaned, and tack coated in accordance with 302-5.4, "Tack Coat" before replacing the asphalt pavement. Please refer to the Contract Documents.
- h. Base repair areas where failed pavement is removed either by cold milling or by excavation shall be restored to existing pavement grade with "Class 2 Aggregate Base (Scheduled, 5 Inch)" and "Class 2 Aggregate Base (Unscheduled, 5 Inch)" at 5 inches, and 5 inches of "Asphalt Concrete Base" shall be placed atop the layer of "Class 2 Aggregate Base (Scheduled, 5 Inch)" and "Class 2 Aggregate Base (Unscheduled, 5 Inch)" unless otherwise directed by the Engineer. These areas have been identified in the Contract Documents as "DO". The Crushed Miscellaneous Base shall be in accordance with 200-2.9, "Class 2 Aggregate Base (Scheduled, 5 Inch)" and "Class 2 Aggregate Base (Unscheduled, 5 Inch)" The "asphalt concrete base" shall be Type III-B3-PG 64-10 as specified in 203-6, "ASPHALT CONCRETE". "General" Preliminary quantities are identified in the Contract Documents but may need to be increased and approved by the Engineer at the time of construction. Base Repairs shall not exceed 25% RAP in content.
- i. Base repair with asphalt concrete base areas where failed pavement is removed either by cold milling or by excavation shall be restored to existing pavement grade with Asphalt Concrete Base at 8 inch (203.2mm) and a minimum of 2 or 3 inches of asphalt concrete shall be placed atop the layer of Asphalt Concrete Base unless otherwise directed by the Engineer. The asphalt concrete base shall be Type III-B3-PG 64-10 as specified in 203-6, "ASPHALT CONCRETE." The asphalt concrete shall be Type III-C2-PG 64-10 as specified in 203-6, "General". Base Repairs shall not exceed 25% RAP in content. Base Repairs with Asphalt Concrete Base shall not be performed except where directed by the Engineer.
- j. A Base repair identified prior to initiation of the preparatory work shall be considered scheduled.
- k. A base repair is considered unscheduled when it is not identified in the Contract Documents as "DO" prior to initiation of preparatory work or

when you are directed by the Engineer to perform an unscheduled base repair for the proper placement of an asphalt overlay.

- I. At the end of each day the Contractor shall submit to the Engineer an itemized list of the asphalt pavement and base repair work completed. The list shall include but not be limited to the location of the work, the exact square footage of the repair, cubic yards of excavation, tons of asphalt concrete base placed, and tons of Class 2 aggregate base material placed or as directed by the Engineer.

**301-1.7 Payment.** To the "WHITEBOOK", DELETE in its entirety and SUBSTITUTE with the following:

1. The demolition, removal, and disposal of various types of existing hardscape in parkway areas, such as colored concrete, bricks, flagstone in the parkway or right-of-way, shall be included under the lump sum Bid items or for the Contract Unit Prices for which hardscape removal is required. When required, hardscape in parkways shall be replaced with Class A Top Soil or as directed by the Engineer.
2. The payment for the preparatory works shall be included in the lump sum Bid Items and Contract Unit Prices for which preparation works are performed, unless it is specified as a separate Bid Item.
3. The areas and quantities shown in the Contract Documents are given only for the Contractor's aid in planning the Work and preparing Bids. The Engineer will designate the limits to be removed and prepared and these designated areas shall be considered to take precedence over the areas shown in the Contract Documents. The quantities shown in the Contract Documents are based on a street assessment survey and may vary. No payment shall be made for areas of over excavation as determined by the Engineer.
4. Asphalt pavement subgrade repair, and base repair dig-outs, shall be paid at the Contract unit price for "Excavate and Export (Scheduled, 10 Inch)" and "Excavate and Export (Unscheduled, 10 Inch)", "Asphalt Concrete Base (Scheduled, 5 Inch)" and "Asphalt Concrete Base (Unscheduled, 5 Inch)", "Class 2 Aggregate Base (Scheduled, 5 Inch)" and "Class 2 Aggregate Base (Unscheduled, 5 Inch)". No Payment shall be made for areas of over excavation as determined by the Engineer.
5. When Cold Milling is used as a method for excavation for subgrade or base repair for pavement, Cold Milling shall be included in the Contract Unit Price for "Excavate and Export (Scheduled, 10 Inch)" or "Excavate and Export (Unscheduled, 10 Inch)".
6. The payment for Excavation shall be paid at the Contract Unit Price for "Excavate and Export (Scheduled, 10 Inch)" or "Excavate and Export (Unscheduled, 10 Inch)" for each bank cubic yard of material removed. Proof

of proper disposal and/or recycling at a legal site for quantities excavated shall be required in advance of payment as directed by the Engineer and shall be subject to approval by the Engineer for payment. No additional payment shall be made for milling, grinding, saw cutting, hauling, disposal of concrete, pavement fabric, rubberized material, steel reinforcement, or any other material.

7. No additional payment shall be made for milling, grinding, saw cutting, stockpiling, hauling, disposal of concrete, pavement fabric, rubberized material, steel reinforcement, or any other material.

**301-2.4 Measurement and Payment.** To the "GREENBOOK", ADD the following:

The contract unit price paid for **Class 2 Aggregate Base** shall include full compensation for furnishing all labor, materials, tools, equipment for the excavation and export of subgrade material under concrete structures, curb, or sidewalks and the placement of compacted Class 2 Aggregate Base at a thickness as directed by the Engineer in areas where compaction of the existing subbase is not sufficient.

**SECTION 302 – ROADWAY SURFACING**

**302-5.2 Pavement Restoration Adjacent to Trench.** To the "WHITEBOOK", DELETE in its entirety and SUBSTITUTE with the following:

**302-5.2 Pavement Restoration Adjacent to Trench Influence Zone.**

1. The Work for pavement restoration shall include the replacement of existing pavement outside of the trench influence zone in accordance with SECTION 302 – ROADWAY SURFACING, and as shown on the Plans.
2. Prior to the commencement of the Work, you shall meet with the Engineer and determine the limits of the pavement to be replaced.
3. Existing pavement shall be removed in accordance with SECTION 404 – COLD MILLING, and as shown on the Plans.
4. Areas of damaged pavement requiring base repair Work shall be restored in accordance with Section 301-1.6, "Preparatory Repair Work", and as shown on the Plans.

**302-5.2.1 Measurement and Payment.** To the "WHITEBOOK", DELETE in its entirety and SUBSTITUTE with the following:

1. The payment for asphalt concrete pavement restoration outside of the trench influence zone shall be made on a tonnage basis in accordance with Section 302-5.9, "Measurement and Payment", and paid for under Bid Item "Asphalt Concrete Overlay (2 Inch)", unless separate Bid items have been provided. The following shall be included in the payment for "Asphalt Concrete Overlay (2 Inch)":
  - a) Saw-cutting existing edges.
  - b) Applying tack coat.

- c) Placement, curing, and protection of new pavement.
- 2. The payment for removal of existing asphalt concrete pavement shall be made on square foot basis in accordance with Section 404-12, "Payment", and paid for under Bid Item "Cold Milling (2 Inch)".
- 3. The payment for base repair Work shall be made in accordance with Section 301-1.7, "Payment".

**302-5.4 Tack Coat.** To the "WHITEBOOK", ADD the following:

- 3. Prior to applying the tack coat, submit calculations for the minimum spray rate required to achieve the minimum residual rate.

**302-6.1 General.** To the "WHITEBOOK", item 3, DELETE in its entirety and SUBSTITUTE with the following:

- 3. The thickness of the new concrete pavement shall be in accordance with Standard Drawing SDG-108, "Pavement Restoration for Concrete Surfaced Streets and Alleys - Major Excavation".

### **SECTION 303 – CONCRETE AND MASONRY CONSTRUCTION**

**303-5.10.1 Installation.** To the "WHITEBOOK", ADD the following:

- 8. Where it is infeasible for a curb ramp run to intersect the street grade at the maximum allowable slope, a slope steeper than 8.33% may be used to limit the ramp run length to 15 ft. The 15-foot measurement excludes landings and shall measure the inside back edge of a sidewalk radius.

**303-5.10.2 Payment.** To the "WHITEBOOK", item 1 and item 2, DELETE in their entirety and SUBSTITUTE with the following:

- 1. The payment for each curb ramp shall include:
  - a. Ramp runs & transition areas (up to 15 ft),
  - b. Landings,
  - c. DWTs,
  - d. Demolition and disposal,
  - e. Forming,
  - f. Relocating or raising items in conflict to grade,
  - g. Protecting and preserving existing survey monuments and improvements,
  - h. Restoring pavement.
- 2. Additional concrete sidewalk and curb quantities beyond 15 feet (4.6 m), measured from the inside back edge of the sidewalk radius where it intersects

with the landing, shall be included in the Bid items for "Additional Sidewalk" and "Additional Curb".

### **SECTION 304 METAL FABRICATION AND CONSTRUCTION**

**304-1.12.4 Payment.** To the "GREENBOOK", ADD the following:

1. The contract Unit Price paid for "**Bridge Railing (ST-75B)**" shall include full compensation for furnishing all labor, materials, tools, equipment, and incidentals including, but not limited to all excavations, material export and import, shop drawings, verification of existing conditions, fabrication, concrete, epoxy coated rebar, steel, footings, curb and gutter in front of the Bridge Railing, and for doing all the work involved in furnishing and installing the Bridge Railing (ST-75B) complete in place as shown on the plans as specified in the Standard Specifications, Caltrans Standard Specifications, these Special Provisions, and as directed by the Engineer. Hollow Structural Sections (HSS) steel shall be galvanized dull grey (coated with copper sulfate solution) per Caltrans Standard Specification 75-10.2. The Unit Price includes temporary measures for vehicle impacts including the installation of temporary water filled barrels prior to installation of crash cushions.
2. The contract Unit Price paid for each "**End Block**" shall include full compensation for furnishing all labor, materials, tools, equipment, and incidentals including, but not limited to all excavations, material export and import, shop drawings, verification of existing conditions, fabrication, concrete and epoxy coated rebar, footings, curb and gutter in front of the Departure End Block, and for doing all the work involved in furnishing and installing the Departure End Block complete in place as shown on the plans as specified in the Standard Specifications, Caltrans Standard Specifications, these Special Provisions, and as directed by the Engineer. The Unit Price includes temporary measurement for vehicle impacts including the installation of temporary water filled barrels prior to installation of crash cushions.
3. The contract Unit Price paid for each "**Crash Cushion**" shall include full compensation for furnishing all labor, materials, tools, equipment, and incidentals including, but not limited to all excavations, material export and import, shop drawings, verification of existing conditions, fabrication, steel, concrete and epoxy coated rebar foundation, modified curb and gutter fronting the Crash Cushion and for doing all the work involved in furnishing and installing the Crash Cushion complete in place as shown on the plans as specified in the Standard Specifications, Caltrans Standard Specifications, these Special Provisions, and as directed by the Engineer.

## SECTION 306 – OPEN TRENCH CONDUIT CONSTRUCTION

**306-1 GENERAL.** To the "GREENBOOK", ADD the following:

1. All Work under this section shall be subject to the applicable permanent resurfacing restoration requirements in accordance with the following City of San Diego Standard Drawings.
  - a) SDG-105, "Pavement Restoration General Notes"
  - b) SDG-107, "Pavement Restoration for Asphalt Concrete Surfaced Streets - Major Excavation"
  - c) SDG-108, "Pavement Restoration for Concrete Surfaced Streets and Alleys - Major Excavation"
  - d) SDG-117, "Pavement Restoration for Asphalt Concrete Surface Streets - Minor Excavation"
  - e) SDG-118, "Pavement Restoration for Concrete Surface Streets and Alleys - Minor Excavation"

**306-3.3.4 Payment.** To the "WHITEBOOK", ADD the following:

12. The payment for pavement restoration including influence area shall be included in the Bid items for the associated abandonment Work.

**306-15 PAYMENT.** To the "GREENBOOK", ADD the following:

1. Payment for pavement restoration, including influence area, shall be included in the associated Bid items pertinent to the Work.

**306-15.1 General.** To the "WHITEBOOK", item 1, subitem n, DELETE **in** its entirety and SUBSTITUTE with the following:

- n) Permanent resurfacing. See **306-1 GENERAL** for permanent pavement restoration requirements.

**306-15.6 Hydrants.** To the "WHITEBOOK", ADD the following:

5. Payment for pavement restoration, including influence area, shall be included in the associated Bid items pertinent to the Work.
6. See **306-1 GENERAL** for permanent resurfacing requirements.

**306-15.7 Buried Structures.** To the "WHITEBOOK", DELETE in its entirety and SUBSTITUTE with the following:

**306-15.7 Buried Structures.** To the "GREENBOOK", sentence (3), DELETE in its entirety and SUBSTITUTE with the following:

The Contract Unit Price shall include excavation, backfill, disposal of all excess excavation, constructing inverts, furnishing and installing castings, restoration of the street surface (See **306-1 GENERAL** for permanent resurfacing requirements) and improvements including but not limited to sidewalk panel, and all other Work,

excluding temporary resurfacing, necessary to construct the buried structure, complete in-place.

**306-15.8 Pipeline Appurtenances.** To the "WHITEBOOK", ADD the following:

10. Payment for pipeline appurtenances will be made at the contract unit price for each appurtenance of the size including permanent resurfacing requirements. See **306-1 GENERAL** for permanent resurfacing requirements.
11. The Payment for furnishing and installation of new water meter box shall be included in the Bid item for "**Meter Box**".
12. Payment for excavating and relocating water services including all shutdowns, coordination, and all labor and materials to relocate the water service with new piping (size and material per plan), connection to existing pipe, and removal of conflicting piping complete as shown on the plans as specified in the Standard Specifications, City of San Diego Whitebook, these Special Provisions, and as directed by the Engineer shall be included in the Bid Item for "**Relocate Water Service**".

**306-16.6 Payment.** To the "WHITEBOOK", ADD the following:

6. All Work under this section shall be subject to the applicable permanent resurfacing restoration requirements in accordance with the following City of San Diego Standard Drawings. Payment for pavement restoration, including influence area, shall be included in the associated Bid items pertinent to the Work.
  - a) See **306-1 GENERAL** for permanent resurfacing requirements.

**306-17.2 Payment.** To the "WHITEBOOK", ADD the following:

12. All Work under this section shall be subject to the applicable permanent resurfacing restoration requirements in accordance with the following City of San Diego Standard Drawings. Payment for pavement restoration, including influence area, shall be included in the associated Bid items pertinent to the Work.
13. See **306-1 GENERAL** for permanent resurfacing requirements.

**SECTION 400 – PROTECTION AND RESTORATION**

**400-1 GENERAL.** To the "WHITEBOOK", ADD the following:

6. All Work under this section shall be subject to the applicable permanent resurfacing restoration requirements in accordance with the following City of San Diego Standard Drawings. Payment for pavement restoration, including influence area, shall be included in the associated Bid Items pertinent to the Work.
  - a) SDG-105, "Pavement Restoration General Notes"

- b) SDG-107, "Pavement Restoration for Asphalt Concrete Surfaced Streets - Major Excavation"
- c) SDG-108, "Pavement Restoration for Concrete Surfaced Streets and Alleys - Major Excavation"
- d) SDG-117, "Pavement Restoration for Asphalt Concrete Surface Streets - Minor Excavation"
- e) SDG-118, "Pavement Restoration for Concrete Surface Streets and Alleys - Minor Excavation"

#### **SECTION 401 – REMOVAL**

**401-3.1 Concrete Pavement.** To the "WHITEBOOK", ADD the following:

- 4. See Section **400-1 GENERAL** for permanent resurfacing requirements.

**401-3.2 Concrete Curb, Walk, Gutters, Cross Gutters, Curb Ramps, Driveway, and Alley Intersections.** To the "WHITEBOOK", ADD the following:

- 6. See Section **400-1 GENERAL** for permanent resurfacing requirements.

#### **SECTION 402 – UTILITIES**

**402-1.1 General.** To the "GREENBOOK", paragraph 5, DELETE in its entirety and SUBSTITUTE with the following:

The Contractor shall complete excavation, backfill, and placement of temporary resurfacing on the same Day. Backfill shall conform to 306-12 Temporary resurfacing shall conform to 306-13.1. Permanent resurfacing shall be placed within 10 Working Days unless otherwise specified in the Special Provisions or directed by the Engineer. See Section **400-1 GENERAL** for permanent resurfacing requirements.

To the "WHITEBOOK", item 2, DELETE in its entirety and SUBSTUTUTE with the following:

- 1. You shall fill all potholes on the same day of potholing if no trenching is to be performed within 10 Working Days of the excavation. Fully restore all potholes and any damaged surrounding areas to their original condition unless otherwise specified by the Engineer. Permanent resurfacing shall conform to SDG-123, "36-Inch and Smaller Pothole and Exploratory Excavation".

**402-2 PROTECTION.** To the “WHITEBOOK”, item 2, ADD the following:

- g) Refer to **Appendix H - Advanced Metering Infrastructure (AMI) Device Protection** for more information on the protection of AMI devices.

**402-4 Relocation.** To the “GREENBOOK”, ADD the following:

Notify Utility prior to excavating within 10 feet of utility facilities.

The construction schedule will need to account for utility relocation activities. You must coordinate with the utility companies for the relocations. Details regarding the utilities and type of work are described in detail in the table below for work shown on plan sheets 0101250-01-D through 0101250-10-D.

Utility	Contact	Lead Time	Work Window	Stage of construction prior to utility work	Type of work to be conducted by utilities
SDG&E Electrical	Project Planner - TBD  SDG&E Contact Alex Velez <a href="mailto:avelez@sdge.com">avelez@sdge.com</a> 619-540-3962	8-12 weeks	Adjusting a single lid requires about 1 to 2 days of work	Sidewalk installation	Adjust pull box and lid to grade
AT&T	Jeffrey Espiritu <a href="mailto:je4541@att.com">je4541@att.com</a> 858.531.6386	2 weeks	1-3 days; depending box needs to be raised in phases	If new curb is set ideally or if new elevation is staked	Adjust pull box and lid to grade

**402-6 COOPERATION.** To the “WHITEBOOK”, DELETE in its entirety and SUBSTITUTE with the following:

- 1. Notify SDG&E at least 30 Working Days prior to excavating within 10 feet of SDG&E Underground High Voltage Transmission Power Lines (69 KV and higher).

**402-8 PAYMENT.** To the “WHITEBOOK”, ADD the following:

- 6. Payment for pavement restoration, including influence area, shall be included in the associated Bid items pertinent to the Work.

## SECTION 404 - COLD MILLING

**404-1 GENERAL.** To the "WHITEBOOK", item 1, DELETE in its entirety and SUBSTITUTE with the following:

1. Excessive asphalt concrete pavement adjacent to Type "G" and "H" curb and gutter lines and concrete cross gutters shall be milled in accordance with the City of San Diego Standard Drawing SDG-107, "Pavement Restoration for Asphalt Concrete Surfaced Streets - Major Excavation", or as shown on the Plans.

## SECTION 700 - MATERIALS

**700-1.3 (86-1.02B) Conduit.** To the "WHITEBOOK", item 1, DELETE in its entirety and SUBSTITUTE with the following:

1. When approved by the Engineer, conduit runs shown on the plans to be located behind curbs may be installed in the street, within 4 feet of and parallel to the curb, by narrow trenching. All pull boxes shall be located behind the curb or at locations shown on the plans. Narrow trenching shall be performed in accordance with the latest City Standards. Any changes in conduit location shall be approved in advance by the Engineer. All narrow trenching shall conform to the City of San Diego Standard Drawings SDG-117, "Pavement Restoration for Asphalt Concrete Surface Streets - Minor Excavation", SDG-118, "Pavement Restoration for Concrete Surface Streets and Alleys - Minor Excavation" and be inspected prior to backfill. Trenches behind sidewalks shall be compacted using compaction tools to ensure no sinking of trench will occur. Trenches wider than 6 inch (15.2 cm) shall conform to the City of San Diego Standard Drawings SDG-107, "Pavement Restoration for Asphalt Concrete Surfaced Streets - Major Excavation", SDG-108, "Pavement Restoration for Concrete Surfaced Streets and Alleys - Major Excavation", and SDG-119, "Trench Types G, H & I Backfill for Dry Utility". A 3-inch (7.6 mm) bed of fine soil or sand shall be placed in the trench.

## SECTION 701 - CONSTRUCTION

**701-2 PAYMENT.** To the "WHITEBOOK", item 3, DELETE in its entirety and SUBSTITUTE with the following:

3. The payment for the trenching and pavement restoration, including influence areas, is included in the payment for the associated Work.

To the "WHITEBOOK", Item 5, ADD following:

- u) Payment for furnishing and installation of new pull box shall be included in the Bid item for "**Pull Box**".
- v) Payment for furnishing and installing new traffic signs and posts, salvaging signs and placing them on new posts and the installation of all signage as

depicted in the Contract Documents shall be included in the Bid item for  
**"Traffic Roadway Signage"**.

**SECTION 1001 – CONSTRUCTION BEST MANAGEMENT PRACTICES (BMPs)**

**1001-1**      **GENERAL.** To the "WHITEBOOK", ADD the following:

8.      Based on a preliminary assessment by the City, this Contract is subject to  
**WPCP.**
-

**SUPPLEMENTARY SPECIAL PROVISIONS**  
**APPENDICES**

**APPENDIX A**  
**NOTICE OF EXEMPTION**

**NOTICE OF EXEMPTION**

TO: \_\_\_\_\_ Recorder/County Clerk  
P.O. Box 1750, MS A-33  
1600 Pacific Hwy, Room 260  
San Diego, CA 92101-2400

FROM: City of San Diego  
Engineering & Capital Projects Department  
525 B Street, Suite 750, MS 908A  
San Diego, CA 92101

\_\_\_\_\_ Office of Planning and Research  
1400 Tenth Street, Room 121  
Sacramento, CA 95814

**Project Name:** Torrey Pines Road, Prospect-Coast Walk Guardrail

**WBS No.:** B-19056.02.06

**Project Location-Specific:** The project is located along the north side of Torrey Pines Road, between Prospect Avenue and Coast Walk, within the La Jolla Community Planning Area (Council District 1).

**Project Location-City/County:** San Diego/San Diego

**Description of nature and purpose of the Project:** The project will replace approximately 591 linear feet (LF) of existing sidewalks, curbs, and gutters along the north side of Torrey Pines Road, between Prospect Street and Coast Walk, with new sidewalks, curbs, and gutters. It will also remove the existing, temporary K-rail barrier and install approximately 350 LF of permanent, California ST-75-type guardrail that will be anchored along the new sidewalk and curb.

**Name of Public Agency Approving Project:** City of San Diego

**Name of Person or Agency Carrying Out Project:** City of San Diego  
Engineering and Capital Projects Department  
Contact: Eriberto J. Valdez Jr.  
Email/Phone No.: EJValdez@sandiego.gov / (619) 533-5191  
525 B Street, Suite 750 (MS 908A), San Diego, CA 92101

Exempt Status:

- Ministerial (Sec. 21080(b)(1); 15268);
- Declared Emergency (Sec. 21080(b)(3); 15269(a));
- Emergency Project (Sec. 21080(b)(4); 15269 (b)(c))
- Categorical Exemption: Section 15301 – Existing Facilities; Section 15302 – Replacement or Reconstruction; 15303 – New Construction or Conversion of Small Structures
- Statutory Exemptions:

**Reasons why project is exempt:** The City of San Diego conducted an environmental review which determined that the project meets the categorical exemption criteria as set forth in CEQA State Guidelines, Section 15301 (Existing Facilities), which allows for the repair, maintenance, and minor alteration of existing public facilities, such as sidewalk and curb and gutter; Section 15302 (Replacement or Reconstruction), which allows for the replacement or reconstruction of existing structures and facilities where the new structures will be located on the same site as the structure replaced and will have substantially the same purpose and capacity as the structure replaced, such as sidewalks, curb, and gutter and k-rails; Section 15303 (New Construction or Conversion of Small Structures), which allows for the construction and location of limited numbers of new, small structures, such as new guardrails.; and where the exceptions listed in Section 15300.2 would not apply.

Lead Agency Contact Person: Eriberto J. Valdez Jr.

Telephone: (619) 533-5191

If filed by applicant:

1. Attach certified document of exemption finding.
2. Has a notice of exemption been filed by the public agency approving the project? ( ) Yes ( ) No

It is hereby certified that the City of San Diego has determined the above activity to be exempt from CEQA.



Carrie Purcell, Deputy Director

2/19/25

Date

Check One:

(X) Signed By Lead Agency

( ) Signed by Applicant

Date Received for Filing with County Clerk or OPR:

**APPENDIX B**  
**FIRE HYDRANT METER PROGRAM**

<b>CITY OF SAN DIEGO CALIFORNIA DEPARTMENT INSTRUCTIONS</b>	<b>NUMBER DI 55.27</b>	<b>DEPARTMENT Water Department</b>
<b>SUBJECT  FIRE HYDRANT METER PROGRAM (FORMERLY: CONSTRUCTION METER PROGRAM)</b>	<b>PAGE 1 OF 10</b>	<b>EFFECTIVE DATE  October 15, 2002</b>
	<b>SUPERSEDES DI 55.27</b>	<b>DATED April 21, 2000</b>

1. **PURPOSE**

- 1.1 To establish a Departmental policy and procedure for issuance, proper usage and charges for fire hydrant meters.

2. **AUTHORITY**

- 2.1 All authorities and references shall be current versions and revisions.
- 2.2 San Diego Municipal Code (NC) Chapter VI, Article 7, Sections 67.14 and 67.15
- 2.3 Code of Federal Regulations, Safe Drinking Water Act of 1986
- 2.4 California Code of Regulations, Titles 17 and 22
- 2.5 California State Penal Code, Section 498B.0
- 2.6 State of California Water Code, Section 110, 500-6, and 520-23
- 2.7 Water Department Director

**Reference**

- 2.8 State of California Guidance Manual for Cross Connection Programs
- 2.9 American Water Works Association Manual M-14, Recommended Practice for Backflow Prevention
- 2.10 American Water Works Association Standards for Water Meters
- 2.11 U.S.C. Foundation for Cross Connection Control and Hydraulic Research Manual

3. **DEFINITIONS**

- 3.1 **Fire Hydrant Meter:** A portable water meter which is connected to a fire hydrant for the purpose of temporary use. (These meters are sometimes referred to as Construction Meters.)

<b>CITY OF SAN DIEGO CALIFORNIA DEPARTMENT INSTRUCTIONS</b>	<b>NUMBER DI 55.27</b>	<b>DEPARTMENT Water Department</b>
<b>SUBJECT  FIRE HYDRANT METER PROGRAM (FORMERLY: CONSTRUCTION METER PROGRAM)</b>	<b>PAGE 2 OF 10</b>	<b>EFFECTIVE DATE  October 15, 2002</b>
	<b>SUPERSEDES DI 55.27</b>	<b>DATED April 21, 2000</b>

- 3.2 **Temporary Water Use:** Water provided to the customer for no longer than twelve (12) months.
- 3.3 **Backflow Preventor:** A Reduced Pressure Principal Assembly connected to the outlet side of a Fire Hydrant Meter.

4. **POLICY**

- 4.1 The Water Department shall collect a deposit from every customer requiring a fire hydrant meter and appurtenances prior to providing the meter and appurtenances (see Section 7.1 regarding the Fees and Deposit Schedule). The deposit is refundable upon the termination of use and return of equipment and appurtenances in good working condition.
- 4.2 Fire hydrant meters will have a 2 ½" swivel connection between the meter and fire hydrant. The meter shall not be connected to the 4" port on the hydrant. All Fire Hydrant Meters issued shall have a Reduced Pressure Principle Assembly (RP) as part of the installation. Spanner wrenches are the only tool allowed to turn on water at the fire hydrant.
- 4.3 The use of private hydrant meters on City hydrants is prohibited, with exceptions as noted below. All private fire hydrant meters are to be phased out of the City of San Diego. All customers who wish to continue to use their own fire hydrant meters must adhere to the following conditions:
  - a. Meters shall meet all City specifications and American Water Works Association (AWWA) standards.
  - b. Customers currently using private fire hydrant meters in the City of San Diego water system will be allowed to continue using the meter under the following conditions:
    - 1. The customer must submit a current certificate of accuracy and calibration results for private meters and private backflows annually to the City of San Diego, Water Department, Meter Shop.

<b>CITY OF SAN DIEGO CALIFORNIA DEPARTMENT INSTRUCTIONS</b>	<b>NUMBER DI 55.27</b>	<b>DEPARTMENT Water Department</b>
<b>SUBJECT  FIRE HYDRANT METER PROGRAM (FORMERLY: CONSTRUCTION METER PROGRAM)</b>	<b>PAGE 3 OF 10</b>	<b>EFFECTIVE DATE  October 15, 2002</b>
	<b>SUPERSEDES DI 55.27</b>	<b>DATED April 21, 2000</b>

2. The meter must be properly identifiable with a clearly labeled serial number on the body of the fire hydrant meter. The serial number shall be plainly stamped on the register lid and the main casing. Serial numbers shall be visible from the top of the meter casing and the numbers shall be stamped on the top of the inlet casing flange.
3. All meters shall be locked to the fire hydrant by the Water Department, Meter Section (see Section 4.7).
4. All meters shall be read by the Water Department, Meter Section (see Section 4.7).
5. All meters shall be relocated by the Water Department, Meter Section (see Section 4.7).
6. These meters shall be tested on the anniversary of the original test date and proof of testing will be submitted to the Water Department, Meter Shop, on a yearly basis. If not tested, the meter will not be allowed for use in the City of San Diego.
7. All private fire hydrant meters shall have backflow devices attached when installed.
8. The customer must maintain and repair their own private meters and private backflows.
9. The customer must provide current test and calibration results to the Water Department, Meter Shop after any repairs.
10. When private meters are damaged beyond repair, these private meters will be replaced by City owned fire hydrant meters.

<b>CITY OF SAN DIEGO CALIFORNIA DEPARTMENT INSTRUCTIONS</b>	<b>NUMBER DI 55.27</b>	<b>DEPARTMENT Water Department</b>
<b>SUBJECT  FIRE HYDRANT METER PROGRAM (FORMERLY: CONSTRUCTION METER PROGRAM)</b>	<b>PAGE 4 OF 10</b>	<b>EFFECTIVE DATE  October 15, 2002</b>
	<b>SUPERSEDES DI 55.27</b>	<b>DATED April 21, 2000</b>

11. When a private meter malfunctions, the customer will be notified and the meter will be removed by the City and returned to the customer for repairs. Testing and calibration results shall be given to the City prior to any re-installation.
  12. The register shall be hermetically sealed straight reading and shall be readable from the inlet side. Registration shall be in hundred cubic feet.
  13. The outlet shall have a 2 ½ “National Standards Tested (NST) fire hydrant male coupling.
  14. Private fire hydrant meters shall not be transferable from one contracting company to another (i.e. if a company goes out of business or is bought out by another company).
- 4.4 All fire hydrant meters and appurtenances shall be installed, relocated and removed by the City of San Diego, Water Department. All City owned fire hydrant meters and appurtenances shall be maintained by the City of San Diego, Water Department, Meter Services.
- 4.5 If any fire hydrant meter is used in violation of this Department Instruction, the violation will be reported to the Code Compliance Section for investigation and appropriate action. Any customer using a fire hydrant meter in violation of the requirements set forth above is subject to fines or penalties pursuant to the Municipal Code, Section 67.15 and Section 67.37.

**4.6 Conditions and Processes for Issuance of a Fire Hydrant Meter**

Process for Issuance

- a. Fire hydrant meters shall only be used for the following purposes:
  1. Temporary irrigation purposes not to exceed one year.

<b>CITY OF SAN DIEGO CALIFORNIA DEPARTMENT INSTRUCTIONS</b>	<b>NUMBER DI 55.27</b>	<b>DEPARTMENT Water Department</b>
<b>SUBJECT  FIRE HYDRANT METER PROGRAM (FORMERLY: CONSTRUCTION METER PROGRAM)</b>	<b>PAGE 5 OF 10</b>	<b>EFFECTIVE DATE  October 15, 2002</b>
	<b>SUPERSEDES DI 55.27</b>	<b>DATED April 21, 2000</b>

2. Construction and maintenance related activities (see Tab 2).
  - b. No customer inside or outside the boundaries of the City of San Diego Water Department shall resell any portion of the water delivered through a fire hydrant by the City of San Diego Water Department.
  - c. The City of San Diego allows for the issuance of a temporary fire hydrant meter for a period not to exceed 12 months (365 days). An extension can only be granted in writing from the Water Department Director for up to 90 additional days. A written request for an extension by the consumer must be submitted at least 30 days prior to the 12 month period ending. No extension shall be granted to any customer with a delinquent account with the Water Department. No further extensions shall be granted.
  - d. Any customer requesting the issuance of a fire hydrant meter shall file an application with the Meter Section. The customer must complete a "Fire Hydrant Meter Application" (Tab 1) which includes the name of the company, the party responsible for payment, Social Security number and/or California ID, requested location of the meter (a detailed map signifying an exact location), local contact person, local phone number, a contractor's license (or a business license), description of specific water use, duration of use at the site and full name and address of the person responsible for payment.
  - e. At the time of the application the customer will pay their fees according to the schedule set forth in the Rate Book of Fees and Charges, located in the City Clerk's Office. All fees must be paid by check, money order or cashiers check, made payable to the City Treasurer. Cash will not be accepted.
  - f. No fire hydrant meters shall be furnished or relocated for any customer with a delinquent account with the Water Department.
  - g. After the fees have been paid and an account has been created, the

<b>CITY OF SAN DIEGO CALIFORNIA DEPARTMENT INSTRUCTIONS</b>	<b>NUMBER DI 55.27</b>	<b>DEPARTMENT Water Department</b>
<b>SUBJECT  FIRE HYDRANT METER PROGRAM (FORMERLY: CONSTRUCTION METER PROGRAM)</b>	<b>PAGE 6 OF 10</b>	<b>EFFECTIVE DATE  October 15, 2002</b>
	<b>SUPERSEDES DI 55.27</b>	<b>DATED April 21, 2000</b>

meter shall be installed within 48 hours (by the second business day). For an additional fee, at overtime rates, meters can be installed within 24 hours (within one business day).

#### 4.7 Relocation of Existing Fire Hydrant Meters

- a. The customer shall call the Fire Hydrant Meter Hotline (herein referred to as “Hotline”), a minimum of 24 hours in advance, to request the relocation of a meter. A fee will be charged to the existing account, which must be current before a work order is generated for the meter’s relocation.
- b. The customer will supply in writing the address where the meter is to be relocated (map page, cross street, etc). The customer must update the original Fire Hydrant Meter Application with any changes as it applies to the new location.
- c. Fire hydrant meters shall be read on a monthly basis. While fire hydrant meters and backflow devices are in service, commodity, base fee and damage charges, if applicable, will be billed to the customer on a monthly basis. If the account becomes delinquent, the meter will be removed.

#### 4.8 Disconnection of Fire Hydrant Meter

- a. After ten (10) months a “Notice of Discontinuation of Service” (Tab 3) will be issued to the site and the address of record to notify the customer of the date of discontinuance of service. An extension can only be granted in writing from the Water Department Director for up to 90 additional days (as stated in Section 4.6C) and a copy of the extension shall be forwarded to the Meter Shop Supervisor. If an extension has not been approved, the meter will be removed after twelve (12) months of use.
- b. Upon completion of the project the customer will notify the Meter Services office via the Hotline to request the removal of the fire hydrant meter and appurtenances. A work order will be generated

<b>CITY OF SAN DIEGO CALIFORNIA DEPARTMENT INSTRUCTIONS</b>	<b>NUMBER DI 55.27</b>	<b>DEPARTMENT Water Department</b>
<b>SUBJECT  FIRE HYDRANT METER PROGRAM (FORMERLY: CONSTRUCTION METER PROGRAM)</b>	<b>PAGE 7 OF 10</b>	<b>EFFECTIVE DATE  October 15, 2002</b>
	<b>SUPERSEDES DI 55.27</b>	<b>DATED April 21, 2000</b>

for removal of the meter.

- c. Meter Section staff will remove the meter and backflow prevention assembly and return it to the Meter Shop. Once returned to the Meter Shop the meter and backflow will be tested for accuracy and functionality.
- d. Meter Section Staff will contact and notify Customer Services of the final read and any charges resulting from damages to the meter and backflow or its appurtenance. These charges will be added on the customer's final bill and will be sent to the address of record. Any customer who has an outstanding balance will not receive additional meters.
- e. Outstanding balances due may be deducted from deposits and any balances refunded to the customer. Any outstanding balances will be turned over to the City Treasurer for collection. Outstanding balances may also be transferred to any other existing accounts.

5. **EXCEPTIONS**

- 5.1 Any request for exceptions to this policy shall be presented, in writing, to the Customer Support Deputy Director, or his/her designee for consideration.

6. **MOBILE METER**

- 6.1 Mobile meters will be allowed on a case by case basis. All mobile meters will be protected by an approved backflow assembly and the minimum requirement will be a Reduced Pressure Principal Assembly. The two types of Mobile Meters are vehicle mounted and floating meters. Each style of meters has separate guidelines that shall be followed for the customer to retain service and are described below:

- a) **Vehicle Mounted Meters:** Customer applies for and receives a City owned Fire Hydrant Meter from the Meter Shop. The customer mounts the meter on the vehicle and brings it to the Meter Shop for

<b>CITY OF SAN DIEGO CALIFORNIA DEPARTMENT INSTRUCTIONS</b>	<b>NUMBER DI 55.27</b>	<b>DEPARTMENT Water Department</b>
<b>SUBJECT  FIRE HYDRANT METER PROGRAM (FORMERLY: CONSTRUCTION METER PROGRAM)</b>	<b>PAGE 8 OF 10</b>	<b>EFFECTIVE DATE  October 15, 2002</b>
	<b>SUPERSEDES DI 55.27</b>	<b>DATED April 21, 2000</b>

inspection. After installation is approved by the Meter Shop the vehicle and meter shall be brought to the Meter Shop on a monthly basis for meter reading and on a quarterly basis for testing of the backflow assembly. Meters mounted at the owner's expense shall have the one year contract expiration waived and shall have meter or backflow changed if either fails.

b) **Floating Meters:** Floating Meters are meters that are not mounted to a vehicle. **(Note: All floating meters shall have an approved backflow assembly attached.)** The customer shall submit an application and a letter explaining the need for a floating meter to the Meter Shop. The Fire Hydrant Meter Administrator, after a thorough review of the needs of the customer, (i.e. number of jobsites per day, City contract work, lack of mounting area on work vehicle, etc.), may issue a floating meter. At the time of issue, it will be necessary for the customer to complete and sign the "Floating Fire Hydrant Meter Agreement" which states the following:

- 1) The meter will be brought to the Meter Shop at 2797 Caminito Chollas, San Diego on the third week of each month for the monthly read by Meter Shop personnel.
- 2) Every other month the meter will be read and the backflow will be tested. This date will be determined by the start date of the agreement.

If any of the conditions stated above are not met the Meter Shop has the right to cancel the contract for floating meter use and close the account associated with the meter. The Meter Shop will also exercise the right to refuse the issuance of another floating meter to the company in question.

Any Fire Hydrant Meter using reclaimed water shall not be allowed use again with any potable water supply. The customer shall incur the cost of replacing the meter and backflow device in this instance.

<b>CITY OF SAN DIEGO CALIFORNIA DEPARTMENT INSTRUCTIONS</b>	<b>NUMBER DI 55.27</b>	<b>DEPARTMENT Water Department</b>
<b>SUBJECT  FIRE HYDRANT METER PROGRAM (FORMERLY: CONSTRUCTION METER PROGRAM)</b>	<b>PAGE 9 OF 10</b>	<b>EFFECTIVE DATE  October 15, 2002</b>
	<b>SUPERSEDES DI 55.27</b>	<b>DATED April 21, 2000</b>

7. **FEE AND DEPOSIT SCHEDULES**

7.1 **Fees and Deposit Schedules:** The fees and deposits, as listed in the Rate Book of Fees and Charges, on file with the Office of the City Clerk, are based on actual reimbursement of costs of services performed, equipment and materials. These deposits and fees will be amended, as needed, based on actual costs. Deposits, will be refunded at the end of the use of the fire hydrant meter, upon return of equipment in good working condition and all outstanding balances on account are paid. Deposits can also be used to cover outstanding balances.

All fees for equipment, installation, testing, relocation and other costs related to this program are subject to change without prior notification. The Mayor and Council will be notified of any future changes.

8. **UNAUTHORIZED USE OF WATER FROM A HYDRANT**

8.1 Use of water from any fire hydrant without a properly issued and installed fire hydrant meter is theft of City property. Customers who use water for unauthorized purposes or without a City of San Diego issued meter will be prosecuted.

8.2 If any unauthorized connection, disconnection or relocation of a fire hydrant meter, or other connection device is made by anyone other than authorized Water Department personnel, the person making the connection will be prosecuted for a violation of San Diego Municipal Code, Section 67.15. In the case of a second offense, the customer's fire hydrant meter shall be confiscated and/or the deposit will be forfeited.

8.3 Unauthorized water use shall be billed to the responsible party. Water use charges shall be based on meter readings, or estimates when meter readings are not available.

8.4 In case of unauthorized water use, the customer shall be billed for all applicable charges as if proper authorization for the water use had been obtained, including but not limited to bi-monthly service charges, installation charges and removal charges.

<b>CITY OF SAN DIEGO CALIFORNIA DEPARTMENT INSTRUCTIONS</b>	<b>NUMBER DI 55.27</b>	<b>DEPARTMENT Water Department</b>
<b>SUBJECT  FIRE HYDRANT METER PROGRAM (FORMERLY: CONSTRUCTION METER PROGRAM)</b>	<b>PAGE 10 OF 10</b>	<b>EFFECTIVE DATE  October 15, 2002</b>
	<b>SUPERSEDES DI 55.27</b>	<b>DATED April 21, 2000</b>

- 8.5 If damage occurs to Water Department property (i.e. fire hydrant meter, backflow, various appurtenances), the cost of repairs or replacements will be charged to the customer of record (applicant).

**Water Department Director**

- Tabs: 1. Fire Hydrant Meter Application  
2. Construction & Maintenance Related Activities With No Return To Sewer  
3. Notice of Discontinuation of Service

#### APPENDIX

**Administering Division:** Customer Support Division

**Subject Index:** Construction Meters  
Fire Hydrant  
Fire Hydrant Meter Program  
Meters, Floating or Vehicle Mounted  
Mobile Meter  
Program, Fire Hydrant Meter

**Distribution:** DI Manual Holders



# Application for Fire Hydrant Meter (EXHIBIT A)

(For Office Use Only)

NS REQ	FAC#
DATE	BY

METER SHOP (619) 527-7449

## Meter Information

Application Date	Requested Install Date:
------------------	-------------------------

Fire Hydrant Location: (Attach Detailed Map//Thomas Bros. Map Location or Construction drawing.) <b>Zip:</b>	T.B.	G.B. (CITY USE)
Specific Use of Water:		
Any Return to Sewer or Storm Drain, if so, explain:		
Estimated Duration of Meter Use:		Check Box if Reclaimed Water

## Company Information

Company Name:			
Mailing Address:			
City:	State:	Zip:	Phone: ( )
*Business license#		*Contractor license#	
A Copy of the Contractor's license OR Business License is required at the time of meter issuance.			
Name and Title of Billing Agent: <small>(PERSON IN ACCOUNTS PAYABLE)</small>			Phone: ( )
Site Contact Name and Title:			Phone: ( )
Responsible Party Name:			Title:
Cal ID#			Phone: ( )
Signature:		Date:	
Guarantees Payment of all Charges Resulting from the use of this Meter. Insures that employees of this Organization understand the proper use of Fire Hydrant Meter			

<b>Fire Hydrant Meter Removal Request</b>	Requested Removal Date:
Provide Current Meter Location if Different from Above:	
Signature:	Title: Date:
Phone: ( )	Pager: ( )

<input type="checkbox"/> City Meter	<input type="checkbox"/> Private Meter
Contract Acct #:	Deposit Amount: <b>\$ 936.00</b> Fees Amount: <b>\$ 62.00</b>
Meter Serial #	Meter Size: <b>05</b> Meter Make and Style: <b>6-7</b>
Backflow #	Backflow Size: Backflow Make and Style:
Name:	Signature: Date:

**WATER USES WITHOUT ANTICIPATED CHARGES FOR RETURN TO SEWER**

Auto Detailing  
Backfilling  
Combination Cleaners (Vactors)  
Compaction  
Concrete Cutters  
Construction Trailers  
Cross Connection Testing  
Dust Control  
Flushing Water Mains  
Hydro Blasting  
Hydro Seeing  
Irrigation (for establishing irrigation only; not continuing irrigation)  
Mixing Concrete  
Mobile Car Washing  
Special Events  
Street Sweeping  
Water Tanks  
Water Trucks  
Window Washing

**Note:**

1. If there is any return to sewer or storm drain, then sewer and/or storm drain fees will be charges.

Date

Name of Responsible Party  
Company Name and Address  
Account Number: \_\_\_\_\_

Subject:           Discontinuation of Fire Hydrant Meter Service

Dear Water Department Customer:

The authorization for use of Fire Hydrant Meter # \_\_\_\_\_, located at *(Meter Location Address)* ends in 60 days and will be removed on or after *(Date Authorization Expires)*. Extension requests for an additional 90 days must be submitted in writing for consideration 30 days prior to the discontinuation date. If you require an extension, please contact the Water Department, or mail your request for an extension to:

City of San Diego  
Water Department  
Attention: Meter Services  
2797 Caminito Chollas  
San Diego, CA 92105-5097

Should you have any questions regarding this matter, please call the Fire Hydrant Hotline at (619) \_\_\_\_\_ - \_\_\_\_\_.

Sincerely,

Water Department

**APPENDIX C**

**MATERIALS TYPICALLY ACCEPTED BY CERTIFICATE OF COMPLIANCE**

## MATERIALS TYPICALLY ACCEPTED BY CERTIFICATE OF COMPLIANCE

1. Soil amendment
2. Fiber mulch
3. PVC or PE pipe up to 16 inch diameter
4. Stabilizing emulsion
5. Lime
6. Preformed elastomeric joint seal
7. Plain and fabric reinforced elastomeric bearing pads
8. Steel reinforced elastomeric bearing pads
9. Waterstops (Special Condition)
10. Epoxy coated bar reinforcement
11. Plain and reinforcing steel
12. Structural steel
13. Structural timber and lumber
14. Treated timber and lumber
15. Lumber and timber
16. Aluminum pipe and aluminum pipe arch
17. Corrugated steel pipe and corrugated steel pipe arch
18. Structural metal plate pipe arches and pipe arches
19. Perforated steel pipe
20. Aluminum underdrain pipe
21. Aluminum or steel entrance tapers, pipe downdrains, reducers, coupling bands and slip joints
22. Metal target plates
23. Paint (traffic striping)
24. Conductors
25. Painting of electrical equipment
26. Electrical components
27. Engineering fabric
28. Portland Cement
29. PCC admixtures
30. Minor concrete, asphalt
31. Asphalt (oil)
32. Liquid asphalt emulsion
33. Epoxy

**APPENDIX D**

**SAMPLE CITY INVOICE**



**APPENDIX E**  
**LOCATION MAP**

**Torrey Pines Rd, Prospect - Coast Walk Guardrail**

FOR QUESTIONS ABOUT THIS PROJECT  
 Call: (619) 533-4207  
 Email: [engineering@sandiego.gov](mailto:engineering@sandiego.gov)

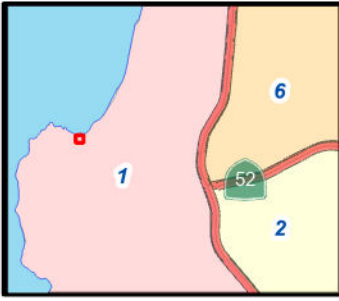

**Legend**

 Proposed Guardrail



THIS MAP/DATA IS PROVIDED WITHOUT WARRANTY OF ANY KIND, EITHER EXPRESS OR IMPLIED, INCLUDING, BUT NOT LIMITED TO, THE IMPLIED WARRANTIES OR MERCHANTABILITY AND FITNESS FOR A PARTICULAR PURPOSE. Note: This product may contain information reproduced with permission from the SANDAG Regional Information System which cannot be reproduced without the written permission of SANDAG. This product may contain information reproduced with permission granted by RAND MCNALLY & COMPANY® to SanGIS. This map is copyrighted by RAND MCNALLY & COMPANY®. It is unlawful to copy or reproduce all or any part thereof, whether for personal use or resale, without the prior, written permission of RAND MCNALLY & COMPANY.

**APPENDIX F**  
**PAVEMENT CORING**

**CITY OF SAN DIEGO  
MEMORANDUM**

**DATE:** September 4, 2025

**TO:** Rhea Vida, Assistant Engineer-Civil, Engineering & Capital Projects

**FROM:** Randy Encinas, Associate Engineer–Civil, Construction Engineering Support

**SUBJECT:** Request for Pavement Coring, Torrey Pines Road Guardrail (B-19056)

---

Per your email requesting coring of the existing street pavement to determine the type and thickness of the pavement for the subject project dated August 8, 2025. Our results are as follow:

Core #	LOCATION	AC	PCC	PAVEMENT FABRIC DEPTH	Base Depth/Type	SE	R-Value
1	Torrey Pines Rd 25' SW of Coast Walk	3 ¾"	7 ½"	N	6" Class II	4	Less than 5
2	Torrey Pines Rd Approx 110' NE of Prospect Pl	4"	8 ½"	N	3' Class II Did not reach native soil		

Should you have any further questions or need additional assistance, please feel free to contact me at (858) 627-3289.

Randy Encinas

Cc: File  
Rimon Zaky

**APPENDIX G**  
**SAMPLE OF PUBLIC NOTICE**



CONSTRUCTION NOTICE

PROJECT TITLE

Work on your street will begin within one week to replace the existing water mains servicing your community.

The work will consist of:

- Saw-cutting and trench work on Ingulf Street from Morena Boulevard to Galveston Street to install new water mains, water laterals and fire hydrants.
• Streets where trenching takes place will be resurfaced and curb ramps will be upgraded to facilitate access for persons with disabilities where required.
• This work is anticipated to be complete in your community by December 2016.

How your neighborhood may be impacted:

- Water service to some properties during construction will be provided by a two-inch highline pipe that will run along the curb. To report a highline leak call 619-515-3525.
• Temporary water service disruptions are planned. If planned disruptions impact your property, you will receive advance notice.
• Parking restrictions will exist because of the presence of construction equipment and materials.
• "No Parking" signs will be displayed 72 hours in advance of the work.
• Cars parked in violation of signs will be TOWED.

Hours and Days of Operation:

Monday through Friday X:XX AM to X:XX PM.

City of San Diego Contractor:

Company Name, XXX-XXX-XXXX



CONSTRUCTION NOTICE

PROJECT TITLE

Work on your street will begin within one week to replace the existing water mains servicing your community.

The work will consist of:

- Saw-cutting and trench work on Ingulf Street from Morena Boulevard to Galveston Street to install new water mains, water laterals and fire hydrants.
• Streets where trenching takes place will be resurfaced and curb ramps will be upgraded to facilitate access for persons with disabilities where required.
• This work is anticipated to be complete in your community by December 2016.

How your neighborhood may be impacted:

- Water service to some properties during construction will be provided by a two-inch highline pipe that will run along the curb. To report a highline leak call 619-515-3525.
• Temporary water service disruptions are planned. If planned disruptions impact your property, you will receive advance notice.
• Parking restrictions will exist because of the presence of construction equipment and materials.
• "No Parking" signs will be displayed 72 hours in advance of the work.
• Cars parked in violation of signs will be TOWED.

Hours and Days of Operation:

Monday through Friday X:XX AM to X:XX PM.

City of San Diego Contractor:

Company Name, XXX-XXX-XXXX

## **APPENDIX H**

### **ADVANCED METERING INFRASTRUCTURE (AMI) DEVICE PROTECTION**

## Protecting AMI Devices in Meter Boxes and on Street Lights

The Public Utilities Department (PUD) has begun the installation of the Advanced Metering Infrastructure (AMI) technology as a new tool to enhance water meter reading accuracy and efficiency, customer service and billing, and to be used by individual accounts to better manage the efficient use of water. **All AMI devices shall be protected per Section 402-2, "Protection", of the 2021 Whitebook.**

AMI technology allows water meters to be read electronically rather than through direct visual inspection by PUD field staff. This will assist PUD staff and customers in managing unusual consumption patterns which could indicate leaks or meter tampering on a customer's property.

Three of the main components of an AMI system are the:

- A. Endpoints, see Photo 1:

**Photo 1**



B. AMI Antenna attached to Endpoint (antenna not always required), see Photo 2:



---

Network Devices, see Photo 3:

**Photo 3**



AMI endpoints transmit meter information to the AMI system and will soon be on the vast majority of meters in San Diego. These AMI devices provide interval consumption data to the PUD's Customer Support Division. If these devices are damaged or communication is interrupted, this Division will be alerted of the situation. The endpoints are installed in water meter boxes, coffins, and vaults adjacent to the meter. A separate flat round antenna may also be installed through the meter box lid. This antenna is connected to the endpoint via cable. The following proper installation shall be implemented when removing the lid to avoid damaging the antenna, cable, and/or endpoint. Photo 4 below demonstrates a diagram of the connection:

**Photo 4**



The AMI device ERT/Endpoint/Transmitter shall be positioned and installed as discussed in this Appendix. If the ERT/Endpoint/Transmitter is disturbed, it shall be re-installed and returned to its original installation with the end points pointed upwards as shown below in Photo 5.

**The PUD's code compliance staff will issue citations and invoices to you for any damaged AMI devices that are not re-installed as discussed in the Contract Document**

Photo 5 below shows a typical installation of an AMI endpoint on a water meter.

**Photo 5**

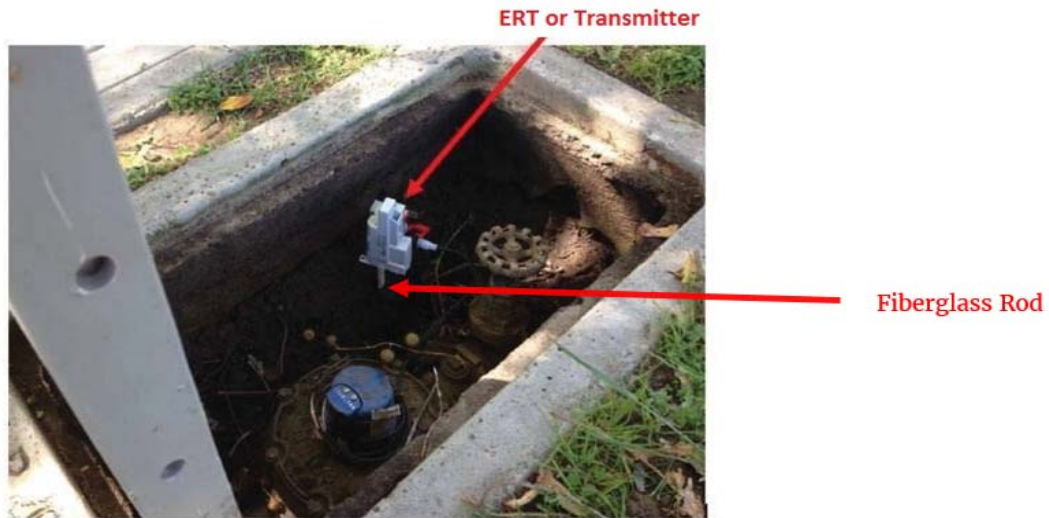

Photo 6 below is an example of disturbance that shall be avoided:

**Photo 6**



**You are responsible when working in and around meter boxes.** If you encounter these endpoints, use proper care and do not disconnect them from the registers on top of the water meter. If the lid has an antenna drilled through, do not change or tamper with the lid and inform the Resident Engineer immediately about the location of that lid. Refer to Photo 7 below:

**Photo 7**



Another component of the AMI system are the Network Devices. The Network Devices are strategically placed units (mainly on street light poles) that collect interval meter reading data from multiple meters for transmission to the Department Control Computer. **If you come across any of these devices on street lights that will be removed or replaced (refer to Photos 8 and 9 below), notify Elvira Santiesteban, Compliance & Metering Manager 619-380-3804 and Kevin Wilson, Senior Water Utility Supervisor 619-857-8257 immediately.**

Photo 8 shows an installed network device on a street light. On the back of each Network Device is a sticker with contact information. See Photo 9. **Call PUD Water Emergency Repairs at 619-515-3525 if your work will impact these street lights.** These are assets that belong to the City of San Diego and you shall be responsible for any costs of disruption of this network.

**Photo 8**



**Network Device**

**Photo 9**



**If you encounter any bad installations, disconnected/broken/buried endpoints, or inadvertently damage any AMI devices or cables, notify the Resident Engineer immediately. The Resident Engineer will then immediately contact Elvira Santiesteban, Compliance & Metering Manager 619-380-3804 and Kevin Wilson, Senior Water Utility Supervisor 619-857-8257.**

Rev. 9.11.2023

**APPENDIX I**

**SAMPLE CONTRACTOR PERFORMANCE EVALUATION (CPE) FORM**



**CITY OF SAN DIEGO  
CONTRACTOR PERFORMANCE EVALUATION (CPE) FORM**

Date: \_\_\_\_\_

**INTERIM EVALUATION:** at \_\_\_\_\_% of a \_\_\_\_\_  Working Day  Calendar Day  
 **FINAL EVALUATION:** Submitted at completion of a \_\_\_\_\_  Working Day  Calendar Day

**TITLE OF CONTRACT:** Title of Contract \_\_\_\_\_

**CONTRACT AMOUNT (ORIGINAL/FINAL)** \_\_\_\_\_ / \_\_\_\_\_

**FIRM NAME:** Contractor Firm Name \_\_\_\_\_

**FIRM ADDRESS:** \_\_\_\_\_

**CONTRACTOR REPRESENTATIVE'S NAME:** \_\_\_\_\_

**CONTRACTOR SUPERINTENDENT'S NAME:** \_\_\_\_\_

**CONTRACTOR FOREMAN'S NAME:** \_\_\_\_\_

**WBS #:** \_\_\_\_\_

**BID #:** \_\_\_\_\_

**TYPE OF WORK** (CHECK ALL THAT APPLY):

TREATMENT PLANT	<input type="checkbox"/>	PUMP STATION	<input checked="" type="checkbox"/>	SEWER MAIN	<input type="checkbox"/>	STORM DRAIN	<input type="checkbox"/>
WATER MAIN	<input type="checkbox"/>	FLOOD CONTROL	<input type="checkbox"/>	ENVTL. MITIGATION	<input type="checkbox"/>	BRIDGE	<input type="checkbox"/>
STREETS/HIGHWAYS	<input type="checkbox"/>	TRAFFIC SIGNAL	<input type="checkbox"/>	STREET LIGHTS	<input type="checkbox"/>	PARK	<input type="checkbox"/>
BUILDING [specify]	<input type="checkbox"/>	PIPING SYSTEM	<input type="checkbox"/>	OTHER (SPECIFY)	<input type="checkbox"/>	_____	

CPE are one of the tools the City uses to determine if a contractor has the quality, fitness, and capacity to perform proposed work satisfactorily and is, therefore, a responsible contractor. See San Diego Municipal Code sections 22.3003 and 22.3004. This evaluation represents the observations and conclusions of the City of San Diego, prepared by City staff in the course of their official duties. The Contractor may agree with or dispute the contents and conclusions of this evaluation. Anyone not affiliated with the City of San Diego should conduct his/her investigation to confirm or dispel the conclusions expressed herein.

**Notes:**

- **The Contractor will be allowed (60) calendar days after notice of the final performance evaluation pursuant to SDMC 22.0806 to protest this evaluation in writing; otherwise, the City will deem the evaluation accepted by the Contractor.**
- **Refer to the end of the form for definitions used in this evaluation.**

### 1. Contract Administration

**The Contractor's overall rating for Section 1 is (check one):**

- Outstanding     Above Satisfactory     Satisfactory     Needs Improvement     Unsatisfactory

### 2. Compliance with Contract Documents

SAMPLE

**The Contractor's overall rating for Section 2 is (check one):**

- Outstanding     Above Satisfactory     Satisfactory     Needs Improvement     Unsatisfactory

### 3. Construction Workmanship

**The Contractor's overall rating for Section 3 is (check one):**

- Outstanding    Above Satisfactory    Satisfactory    Needs Improvement    Unsatisfactory

### 4. Safety

**The Contractor's overall rating for Section 4 is (check one):**

- Outstanding    Above Satisfactory    Satisfactory    Needs Improvement    Unsatisfactory

### 5. Storm Water / BMP Compliance

**The Contractor's overall rating for Section 5 is (check one):**

- Outstanding     Above Satisfactory     Satisfactory     Needs Improvement     Unsatisfactory

### 6. Cooperation, Professionalism, Communication & Public Outreach

**The Contractor's overall rating for Section 6 is (check one):**

- Outstanding     Above Satisfactory     Satisfactory     Needs Improvement     Unsatisfactory

### 7. Subcontracting Performance and Management

**The Contractor's overall rating for Section 7 is (check one):**

- Outstanding     Above Satisfactory     Satisfactory     Needs Improvement     Unsatisfactory

#### OVERALL EVALUATION

THE OVERALL EVALUATION IS DERIVED FROM THE HOLISTIC REVIEW OF THE SEVEN FACTORS ABOVE.

**The Contractor's overall rating (check one):**

- Outstanding     Above Satisfactory     Satisfactory     Needs Improvement     Unsatisfactory

#### OVERALL SUMMARY:

Title of Contract: Title of Contract  
Evaluation of: Contractor Firm Name

Date:  
Page 6 of 9

RESIDENT ENGINEER

SUPERVISOR

By:

\_\_\_\_\_  
(signature / date)

\_\_\_\_\_  
(signature / date)

\_\_\_\_\_  
(print name)

\_\_\_\_\_  
(print name)

Section Head's Initial \_\_\_\_\_

Asst. Deputy Director's Initials \_\_\_\_\_

ADD:

Date: \_\_\_\_\_

CC:

- Contractor
- Program Coordinator, Engineering & Capital Projects/Contracting Group, Pre-qualification Program
- Director, Purchasing & Contracting
- Deputy Director, Purchasing & Contracting
- eFile CityHub/SDShare

SAMPLE

**Definitions:**

- 1. Performance Areas** - These include the Contractor's record of conforming to the requirements and standards of Contract Administration, Compliance with Contract Documents, Construction Workmanship, Safety, Stormwater Best Management Practices, Cooperation, Professionalism, Communication and Public Outreach, and Subcontracting Performance and Management.

Here are definitions for the specified terms within the context of contractor performance areas:

- Contract Administration: Managing all aspects of a construction contract to ensure compliance with its terms and conditions. This includes handling project documentation, managing changes or modifications, e.g., requests for changes, processing payments, monitoring timelines, requests for information, submittals, resolving disputes, and ensuring all parties fulfill their contractual obligations.
- Compliance with Contract Documents: Adherence to the plans, specifications, and other legally binding documents that outline the scope of work, quality standards, and technical requirements. This involves ensuring all construction activities align with approved designs, materials, and regulations specified in the contract.
- Construction Workmanship: The quality and standard of the physical work performed on the project. It reflects the Contractor's ability to deliver durable, precise, and code-compliant construction through skilled labor and proper techniques specified in the contract.
- Safety: Implementing and maintaining measures to protect workers, site visitors, and the public from hazards. This includes compliance with Occupational Safety and Health Administration standards, site-specific safety plans, and accident prevention strategies throughout the project lifecycle.
- Stormwater Best Management Practices (BMPs): Techniques and measures used to control and reduce the impact of stormwater runoff during and after construction. This includes erosion control, sediment barriers, proper waste management, and other strategies to minimize pollution and protect water quality in compliance with environmental regulations.
- Cooperation: The Contractor's ability to work collaboratively and effectively with the City, subcontractors, government agencies, and other stakeholders. This involves being responsive and adaptable and maintaining a solution-oriented approach to project challenges.
- Professionalism: Demonstrating ethical conduct, integrity, and respect in all aspects of the Contractor's work. It includes maintaining a positive work environment, adhering to industry standards, and fostering trust through reliable and responsible business practices.
- Communication and Public Outreach: Providing clear, timely, and accurate information to stakeholders and the public as specified in the Contract Documents. This involves regular project updates, responding to concerns, and maintaining transparency to build positive community relations and ensure all parties remain informed.
- Subcontracting Performance and Management: The contractor's ability to select, oversee, and coordinate Subcontractors to ensure their work meets quality standards, deadlines, and compliance requirements. Effective management includes monitoring performance, enforcing contractual terms, and resolving issues to maintain project continuity.

The above criteria are not equally weighted. For example, though the Contractor may receive an outstanding rating for Contract Administration, Cooperation, Professionalism and/or Communication, the frequent lapses in safety on the job site or disregard for stormwater compliance resulting in serious injury or damages on site justify the Contractor receiving an overall unsatisfactory rating. Therefore, in the context of the Contractor performance ratings, the definitions can be adjusted to focus more on the quality of the Work, timeliness, and adherence to safety standards than other areas.

- 2. Performance Rating** - See below for a breakdown of the Contractor's performance rating definitions. These definitions provide a set of expectations across multiple areas of the Contractor's performance, ensuring the Contractor is evaluated holistically on various critical aspects of contract execution.

**a) Outstanding:**

- Contract Administration: Consistently submits all required documentation on time and maintains proper documentation. Fully adheres to the contract's terms and proactively resolves any issues.
- Compliance with Contract Documents: Demonstrates full understanding of and strict adherence to Contract Documents. Any changes or deviations are well-communicated and documented.
- Construction Workmanship: The quality of the Work consistently exceeds expectations, with few to no defects, attention to detail, and thorough craftsmanship.

- Safety: Safety is a top priority, with zero safety incidents, proactive safety training, and implementing additional safety measures beyond required.
- Storm Water Best Management Practices: Consistently implements and exceeds all environmental guidelines for stormwater management and addresses issues before they arise.
- Cooperation: Fully cooperative with all stakeholders, including the client, Subcontractors, and suppliers, with a strong emphasis on team collaboration and problem-solving.
- Professionalism: Maintains the highest standards of conduct, integrity, and respect in all dealings with stakeholders and regulatory agencies.
- Communication and Public Outreach: Regularly updates stakeholders, responds promptly to concerns, and engages with the public in a respectful and transparent manner. Issues are resolved proactively.
- Subcontracting Performance and Management: Subcontractors are managed effectively, adhering to contract terms and producing high-quality work. Coordination between Subcontractors is seamless.

**b) Above Satisfactory:**

- Contract Administration: Completes necessary documentation with minimal errors and on time. Any issues or changes are addressed promptly.
- Compliance with Contract Documents: Follows Contract Documents well, with only minor discrepancies or deviations that are communicated and resolved.
- Construction Workmanship: Work quality is generally excellent, with a few minor issues or areas for improvement that are promptly corrected.
- Safety: Strong safety record, with minor issues addressed quickly. Safety practices generally meet or exceed expectations.
- Stormwater Best Management Practices: Stormwater management practices are followed effectively, with few issues. Implements best practices and corrects problems when they arise.
- Cooperation: Works well with all parties, addressing issues with minimal conflict. Collaboration is generally smooth.
- Professionalism: Maintains a professional demeanor, resolving conflicts appropriately, and adhering to industry standards.
- Communication and Public Outreach: Communication is proactive and responsive, with timely updates to stakeholders and the public. Public outreach is effective but could be more frequent.
- Subcontracting Performance and Management: Subcontractors are effectively managed, but minor coordination issues may arise. Work is generally on time and meets the standards.

**c) Satisfactory:**

- Contract Administration: Documentation is completed as required, with occasional delays or missing information. Issues are resolved, but reminders may be required.
- Compliance with Contract Documents: Generally, complies with contract documents, with occasional deviations addressed upon discovery but may result in delays or minor issues.
- Construction Workmanship: Meets the minimum expected quality, with some defects or areas that could be improved. Issues are typically addressed once raised.
- Safety: Safety protocols are followed, though there may be occasional minor incidents or near-misses. The overall safety record is acceptable but not exemplary.
- Stormwater Best Management Practices: Meets basic requirements for stormwater management but may not always go above and beyond to exceed environmental standards.
- Cooperation: Cooperation with others is generally acceptable but may not be proactive. Occasionally requires intervention to resolve conflicts or issues.

- Professionalism: Conducts business professionally, though there may be occasional lapses in communication or judgment.
- Communication and Public Outreach: Provides regular updates but may not always engage proactively with stakeholders or the public. Responses are typically timely but occasionally delayed.
- Subcontracting Performance and Management: Subcontractors are managed adequately, though there may be some delays or quality issues. Coordination could be improved.

**d) Needs Improvement:**

- Contract Administration: Frequently submits documentation late or incomplete. Requires frequent reminders to stay on track with contract requirements.
- Compliance with Contract Documents: Regularly deviates from contract documents or fails to follow specifications. Changes or deviations are not always communicated effectively.
- Construction Workmanship: Work quality does not consistently meet the minimum standards. There are frequent defects or the need for rework.
- Safety: Safety violations occur, or safety protocols are inconsistently followed. There are notable safety incidents or risks that need to be addressed.
- Stormwater Best Management Practices: Fails to comply consistently with stormwater management practices, leading to potential environmental concerns or violations.
- Cooperation: Struggles to cooperate with others, leading to frequent conflicts, delays, or miscommunications.
- Professionalism: Displays unprofessional behavior, including poor communication, lack of respect for other stakeholders, or failure to resolve conflicts properly.
- Communication and Public Outreach: Communication is often reactive rather than proactive, failing to inform stakeholders or the public promptly or transparently.
- Subcontracting Performance and Management: Subcontractors are not properly managed, leading to frequent delays, quality issues, or resource mismanagement.

**e) Unsatisfactory:**

- Contract Administration: Consistently fails to submit required documentation, and there are significant discrepancies or ongoing issues with contract compliance.
- Compliance with Contract Documents: Major deviations from contract documents are frequent and unaddressed. The Contractor fails to follow essential specifications or standards.
- Construction Workmanship: The quality of the Work is consistently poor, with widespread defects and the need for significant rework. It is below industry standards.
- Safety: Serious safety violations or significant incidents affecting worker safety or project progress. Safety regulations are often ignored or not implemented.
- Stormwater Best Management Practices: Failure to implement or adhere to environmental best practices leads to violations or significant environmental impacts.
- Cooperation: Exhibits a lack of cooperation, leading to frequent conflicts with stakeholders, delays, and disruptions in project progress.
- Professionalism: Consistently unprofessional behavior, lack of integrity, failure to meet basic expectations for respect and conduct.
- Communication and Public Outreach: Poor or nonexistent communication, leaving stakeholders or the public uninformed. Issues are ignored or not addressed on time.
- Subcontracting Performance and Management: Subcontractors are poorly managed, leading to significant delays, quality issues, or violations of contract terms. Coordination and oversight are lacking.

*Contractor's Performance Evaluation Form  
Revised 01/01/2025*

**ATTACHMENT F**

**IN-USE OFF-ROAD DIESEL FUELED FLEET REGULATION (OFF-ROAD REGULATION)  
COMPLIANCE (CARB)**

## ATTACHMENT F

### IN-USE OFF-ROAD DIESEL FUELED FLEET REGULATION (OFF-ROAD REGULATION) COMPLIANCE

The California Air Resources Board (CARB) approved amendments to the Off-Road Regulations which can be found at 13 California Code of Regulations (CCR) sections 2449, 2449.1, and 2449.2. These amendments apply to any person, business, or government agency who owns or operates within California any vehicles with a diesel-fueled or alternative diesel fueled off-road compression-ignition engine with maximum power (max hp) of 25 horsepower (hp) or greater provided that the vehicle cannot be registered and driven safely on-road or was not designed to be driven on-road, even if it has been modified so that it can be driven safely on-road. See 13 CCR section 2449 (b) for the full list of vehicles covered by these Off-Road Regulations.

Beginning **January 1, 2024**, Contractor shall be subject to the requirements below. No Contractor or public works awarding body, as applicable, shall enter into a contract with a fleet for which it does not have a valid Certificate of Reported Compliance for the fleet and its listed subcontractors, if applicable, prior to entering into a new or renewed contract with that fleet. Contractor shall comply with the following requirements:

- (1) For a project involving the use of vehicles subject to the Off-Road Regulation, Contractor must obtain copies of the valid Certificates of Reported Compliance, as described in 13 CCR section 2449(n), for the fleet selected for this Contract and their listed subcontractors, if applicable, prior to entering into a new or renewed contract with that fleet and provide copies of such Certificates of Reported Compliance to the City within 10 days of issuance of the Notice of Intent to Award letter. Contractor shall enter into a contract with a fleet for which it does not have a valid Certificates of Reported Compliance for the fleet and its listed subcontractors. City shall not enter into a contract with Contractor until all current Certificates of Reported Compliance for the fleet to be used on this Project are provided by Contractor.
- (2) The Certificates of Reported Compliance received by Contractor for this Project must be retained by Contractor for three years after the Project's completion. Upon request by CARB, these records must be provided to CARB within five business days of the request. Additionally, upon request by City, these records must be produced to City within five business days of the request.
- (3) For emergency contracts that meet the definition of "emergency operations" as defined in 13 CCR section 2449(c)(18), they are exempt from the requirements in 13 CCR section 2449(i)(1)-(3) and sections (1) and (2) above, but must still retain records verifying vehicles subject to the regulation that are operating on the "emergency operations" project are actually being operated on the project for "emergency operations" only. These records, as described in more detail below in section (B) must be retained by Contractor for three years after completion of the Project and upon request from either CARB or the City, Contractor shall provide those records to the requesting party within five business days. All other emergency contracts that do not meet the definition of "emergency operations" must comply with the requirements above and 13 CCR section 2449(i)(1) – (3).

- A. "Emergency Operations" is defined as:
1. Any activity for a project conducted during emergency, life threatening situations, where a sudden, unexpected occurrence that poses a clear and imminent danger, requiring immediate action to prevent or mitigate the loss or impairment of life, health, property, or an essential public service; or in conjunction with any officially declared disaster or state of emergency, as declared by an authorized health officer, agricultural commissioner, fire protection officer, or other authorized health officer;
  2. Any activity for a project conducted by essential service utilities to provide electricity, natural gas, telephone, water, or sewer during periods of service outages and emergency; or
  3. Operations including repairing or preventing damage to roads, buildings, terrain, and infrastructure as a result of an earthquake, flood, storm, fire, other infrequent act of nature, or terrorism. Routine maintenance or construction to prevent public health risks does not constitute emergency operations under the Off-Road Regulations.
- B. The records retained by Contractor for "emergency operations" projects must include:
1. A description of the emergency;
  2. The address or a description of the specific location of the emergency;
  3. The dates on which the emergency operations were performed; and
  4. An attestation by the fleet that the vehicles are operated on the Project for "emergency operations" only.

Beginning **January 1, 2024**, Contractor is also subject to the requirements described in 13 CCR section 2449(j).

- (1) Between March 1 and June 1 of each year, Contractor must collect new valid Certificates of Reported Compliance for the current compliance year, as defined in 13 CCR section 2449(n), from all fleets that have an ongoing contract with Contractor as of March 1 of that year. Contractors shall not write contracts to evade this requirement.
- (2) Contractor shall only allow fleets with valid Certificates of Reported Compliance on the Contractor's job sites.
- (3) If Contractor discovers that any fleet intending to operate vehicles subject to this regulation for Contractor does not have a valid Certificate of Reported Compliance, as defined in 13 CCR section 2449(n), or if Contractor observes any noncompliant vehicles subject to the regulation on Contractor's job site, then Contractor must report the that to CARB at <https://calepacomplaints.secure.force.com/complaints/Complaint>, or email [dieselcomplaints@arb.ca.gov](mailto:dieselcomplaints@arb.ca.gov), for each fleet without a valid Certificate of Reported Compliance or each noncompliant vehicle, as applicable, within five business days of such discovery. See 13 CCR 2449(n) for the information required to be disclosed to CARB when reporting non-compliance.

(4) Upon request by CARB, Contractor must immediately disclose to CARB the name and contact information of each responsible party for all vehicles subject to this regulation operating at the job site or for Contractor.

(5) Contractor shall prominently display signage for any project where vehicles subject to this Off-Road Regulation will operate for 8 calendar days or more. The signage must be posted by the eighth calendar day from which the first vehicle operates. The signage will be in lettering larger than size 14-point type and displayed in a conspicuous place where notices to employees are customarily posted at the job site or where there is employee foot traffic. If one of the above locations is also viewable by the public, it should be posted at that location. An exemption to this posting requirement is permitted if the operational time of a project is 7 calendar days or less. The signage must include the following language, verbatim:

(A) Who does the In-Use Off-Road Regulation Apply to?

The In-Use Off-Road Diesel-Fueled Fleets Regulation (Off-Road Regulation) applies to all self-propelled off-road diesel vehicles 25 horsepower or greater and most two-engine vehicles (except on-road two-engine sweepers) owned or operated in California. This includes vehicles that are rented or leased (rental or leased fleets)."

(B) "In-Use Off-Road Regulation Requirements

Idling Limit: Vehicles cannot idle longer than five minutes. There are exceptions for vehicles that need to idle to perform work.

Labeling: Vehicles must be labeled with a CARB assigned equipment identification number (EIN). The EIN shall be white on a red background, unless the vehicle is part of a captive attainment area fleet, in which case the EIN shall be white on a green background.

The EIN shall be located in clear view on both sides of the outside of the vehicle."

**ATTACHMENT G**  
**CONTRACT AGREEMENT**

## ATTACHMENT G

### CONTRACT AGREEMENT

---

#### CONSTRUCTION CONTRACT

This contract is made and entered into between THE CITY OF SAN DIEGO, a municipal corporation, herein called "City", and Palm Engineering Construction Co., Inc., herein called "Contractor" for construction of **TORREY PINES PROSPECT-COAST WALK GUARDRAIL**; Bid No. **K-26-2448-DBB-3**; in the total amount of One Million Three Hundred Thirteen Thousand Two Hundred Twenty Six Dollars and Zero Cents (\$1,313,226.00), which is comprised of the Base Bid.

IN CONSIDERATION of the payments to be made hereunder and the mutual undertakings of the parties hereto, City and Contractor agree as follows:

1. The following are incorporated into this contract as though fully set forth herein:
  - (a) The attached Faithful Performance and Payment Bonds.
  - (b) The attached Proposal included in the Bid documents by the Contractor.
  - (c) Reference Standards listed in the Instruction to Bidders and the Supplementary Special Provisions (SSP).
  - (d) That certain documents entitled **TORREY PINES PROSPECT-COAST WALK GUARDRAIL**, on file in the Purchasing & Contracting Department as Document No. **B-19056** as well as all matters referenced therein.
2. The Contractor shall perform and be bound by all the terms and conditions of this contract and in strict conformity therewith shall perform and complete in a good and workmanlike manner **TORREY PINE PROSPECT-COAST WALK GUARDRAIL**, Bid Number **K-26-2448-DBB-3**, San Diego, California.
3. For such performances, the City shall pay to Contractor the amounts set forth at the times and in the manner and with such additions or deductions as are provided for in this contract, and the Contractor shall accept such payment in full satisfaction of all claims incident to such performances.
4. No claim or suit whatsoever shall be made or brought by Contractor against any officer, agent, or employee of the City for or on account of anything done or omitted to be done in connection with this contract, nor shall any such officer, agent, or employee be liable hereunder.
5. This contract is effective as of the date that the Mayor or designee signs the agreement and is approved by the City Attorney in accordance with San Diego Charter Section 40.

**CONTRACT AGREEMENT (continued)**

**IN WITNESS WHEREOF**, this Agreement is signed by the City of San Diego, acting by and through its Mayor or designee, pursuant to Municipal Code §22.3102 authorizing such execution.

**CONTRACTOR**

By: 

Print Name: Rasoul Shahbazi

Title: President

Date: 04/02/2026

City of San Diego License No.: B2004010181

State Contractor's License No.: 853930

DEPARTMENT OF INDUSTRIAL RELATIONS (DIR) REGISTRATION NUMBER: 2000000411

**THE CITY OF SAN DIEGO**

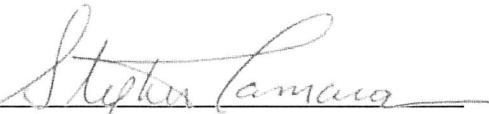
By: 

Print Name: Stephen Samara  
Principal Contract Specialist  
Purchasing & Contracting Department

Date: 5/7/2026

**APPROVED AS TO FORM**

**Heather Ferbert, City Attorney**

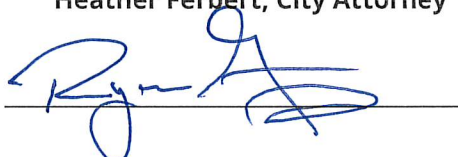
By: 

Print Name: RYAN P. GERRITY  
Deputy City Attorney

Date: 5/13/2026

## **CERTIFICATIONS AND FORMS**

The Bidder, by submitting its electronic bid, agrees to and certifies under penalty of perjury under the laws of the State of California, that the certifications, forms and affidavits submitted as part of this bid are true and correct.

## **BIDDER'S GENERAL INFORMATION**

To the City of San Diego:

Pursuant to "Notice Inviting Bids", specifications, and requirements on file with the City Clerk, and subject to all provisions of the Charter and Ordinances of the City of San Diego and applicable laws and regulations of the United States and the State of California, the undersigned hereby proposes to furnish to the City of San Diego, complete at the prices stated herein, the items or services hereinafter mentioned. The undersigned further warrants that this bid is not made in the interest of, or on behalf of, any undisclosed person, partnership, company, association, organization, or corporation; that the bid is genuine and not collusive or sham; that the bidder has not directly or indirectly induced or solicited any other bidder to put in a false or sham bid, and has not directly or indirectly colluded, conspired, connived, or agreed with any bidder or anyone else to put in a sham bid, or that anyone shall refrain from bidding; that the bidder has not in any manner, directly or indirectly, sought by agreement, communication, or conference with anyone to fix the bid price of the bidder or any other bidder, or to fix any overhead, profit, or cost element of the bid price, or of that of any other bidder, or to secure any advantage against the public body awarding the contract of anyone interested in the proposed contract; that all statements contained in the bid are true; and, further, that the bidder has not, directly or indirectly, submitted his or her bid price or any breakdown thereof, or the contents thereof, or divulged information or data relative thereto, or paid, and will not pay, any fee to any corporation, partnership, company, association, organization, bid depository, or to any member or agent thereof to effectuate a collusive or sham bid.

The undersigned bidder(s) further warrants that bidder(s) has thoroughly examined and understands the entire Contract Documents (plans and specifications) and the Bidding Documents therefore, and that by submitting said Bidding Documents as its bid proposal, bidder(s) acknowledges and is bound by the entire Contract Documents, including any addenda issued thereto, as such Contract Documents incorporated by reference in the Bidding Documents.

**NON-COLLUSION AFFIDAVIT TO BE EXECUTED BY BIDDER AND SUBMITTED WITH BID UNDER 23  
UNITED STATES CODE 112 AND PUBLIC CONTRACT CODE 7106**

State of California

County of San Diego

The bidder, being first duly sworn, deposes and says that he or she is authorized by the party making the foregoing bid that the bid is not made in the interest of, or on behalf of, any undisclosed person, partnership, company, association, organization, or corporation; that the bid is genuine and not collusive or sham; that the bidder has not directly or indirectly induced or solicited any other bidder to put in a false or sham bid, and has not directly or indirectly colluded, conspired, connived, or agreed with any bidder or anyone else to put in a sham bid, or that anyone shall refrain from bidding; that the bidder has not in any manner, directly or indirectly, sought by agreement, communication, or conference with anyone to fix the bid price of the bidder or any other bidder, or to fix any overhead, profit, or cost element of the bid price, or of that of any other bidder, or to secure any advantage against the public body awarding the contract of anyone interested in the proposed contract; that all statements contained in the bid are true; and further, that the bidder has not, directly or indirectly, submitted his or her bid price or any breakdown thereof, or the contents thereof, or divulged information or data relative thereto, or paid, and will not pay, any fee to any corporation, partnership, company association, organization, bid depository, or to any member or agent thereof to effectuate a collusive or sham bid.

## CONTRACTOR CERTIFICATION

---

### DRUG-FREE WORKPLACE

I hereby certify that I am familiar with the requirements of San Diego City Council Policy No. 100-17 regarding Drug-Free Workplace as outlined in the WHITEBOOK, Section 5-1.3, "Drug-Free Workplace", of the project specifications, and that;

This company has in place a drug-free workplace program that complies with said policy. I further certify that each subcontract agreement for this project contains language which indicates the subcontractor's agreement to abide by the provisions of subdivisions a) through c) of the policy as outlined.

## CONTRACTOR CERTIFICATION

---

### AMERICANS WITH DISABILITIES ACT (ADA) COMPLIANCE CERTIFICATION

I hereby certify that I am familiar with the requirements of San Diego City Council Policy No. 100-4 regarding the Americans With Disabilities Act (ADA) outlined in the WHITEBOOK, Section 5-1.2, "California Building Code, California Code of Regulations Title 24 and Americans with Disabilities Act". of the project specifications, and that:

This company has in place workplace program that complies with said policy. I further certify that each subcontract agreement for this project contains language which indicates the subcontractor's agreement to abide by the provisions of the policy as outlined.

## CONTRACTOR CERTIFICATION

---

### CONTRACTOR STANDARDS – PLEDGE OF COMPLIANCE

I declare under penalty of perjury that I am authorized to make this certification on behalf of the company submitting this bid/proposal, that as Contractor, I am familiar with the requirements of City of San Diego Municipal Code § 22.3004 regarding Contractor Standards as outlined in the WHITEBOOK, Section 5-1.4, ("Contractor Standards and Pledge of Compliance"), of the project specifications, and that Contractor has complied with those requirements.

I further certify that each of the Contractor's subcontractors has completed a Pledge of Compliance attesting under penalty of perjury of having complied with City of San Diego Municipal Code § 22.3004.

## **CONTRACTOR CERTIFICATION**

---

### **EQUAL BENEFITS ORDINANCE CERTIFICATION**

I declare under penalty of perjury that I am familiar with the requirements of and in compliance with the City of San Diego Municipal Code § 22.4300 regarding Equal Benefits Ordinance.

## **CONTRACTOR CERTIFICATION**

---

### **EQUAL PAY ORDINANCE CERTIFICATION**

Contractor shall comply with the Equal Pay Ordinance (EPO) codified in the San Diego Municipal Code (SDMC) at section 22.4801 through 22.4809, unless compliance is not required based on an exception listed in SDMC section 22.4804.

Contractor shall require all of its subcontractors to certify compliance with the EPO in their written subcontracts.

Contractor must post a notice informing its employees of their rights under the EPO in the workplace or job site.

By signing this Contract with the City of San Diego, Contractor acknowledges the EPO requirements and pledges ongoing compliance with the requirements of SDMC Division 48, section 22.4801 et seq., throughout the duration of this Contract.

## CONTRACTOR CERTIFICATION

---

### **IN-USE OFF-ROAD DIESEL FUELED FLEET REGULATION (OFF-ROAD REGULATION) COMPLIANCE**

I hereby certify that Contractor is familiar with the requirements 13 CCR 2449, 2449.1, and 2449.2, as well as Attachment F, In-Use Off-Road Diesel Fueled Fleet Regulation (Off-Road Regulation) Compliance (CARB), and that Contractor shall comply with these requirements.

I further certify that each of the Contractor's listed subcontractors is familiar with these requirements and shall also comply.

## **CONTRACTOR CERTIFICATION**

---

### **PRODUCT ENDORSEMENT**

I declare under penalty of perjury that I acknowledge and agree to comply with the provisions of City of San Diego Administrative Regulation 95.65, concerning product endorsement. Any advertisement identifying or referring to the City as the user of a product or service requires the prior written approval of the City.

**AFFIDAVIT OF DISPOSAL**

(To be submitted upon completion of Construction pursuant to the contracts Certificate of Completion)

**WHEREAS**, on the \_\_\_\_\_ DAY OF \_\_\_\_\_, 2\_\_\_\_\_ the undersigned entered into and executed a contract with the City of San Diego, a municipal corporation, for:

**TORREY PINES PROSPECT-COAST WALK GUARDRAIL**

(Project Title)

as particularly described in said contract and identified as Bid No. **K-26-2448-DBB-3**; SAP No. (WBS) **B-19056**; and **WHEREAS**, the specification of said contract requires the Contractor to affirm that "all brush, trash, debris, and surplus materials resulting from this project have been disposed of in a legal manner"; and **WHEREAS**, said contract has been completed and all surplus materials disposed of:

\_\_\_\_\_  
\_\_\_\_\_

**NOW, THEREFORE**, in consideration of the final payment by the City of San Diego to said Contractor under the terms of said contract, the undersigned Contractor, does hereby affirm that all surplus materials as described in said contract have been disposed of at the following location(s)

\_\_\_\_\_  
\_\_\_\_\_

and that they have been disposed of according to all applicable laws and regulations.

Dated this \_\_\_\_\_ DAY OF \_\_\_\_\_, \_\_\_\_\_.

By: \_\_\_\_\_  
Contractor

**ATTEST:**

State of \_\_\_\_\_ County of \_\_\_\_\_

On this \_\_\_\_\_ DAY OF \_\_\_\_\_, 2\_\_\_\_\_, before the undersigned, a Notary Public in and for said County and State, duly commissioned and sworn, personally appeared \_\_\_\_\_ known to me to be the \_\_\_\_\_ Contractor named in the foregoing Release, and whose name is subscribed thereto, and acknowledged to me that said Contractor executed the said Release.

Notary Public in and for said County and State

COMPANY LETTERHEAD

**CERTIFICATE OF COMPLIANCE**

**Materials and Workmanship Compliance**

For Contract or Task \_\_\_\_\_

I certify that the material listed below complies with the materials and workmanship requirements of the Caltrans Contract Plans, Special Provisions, Standard Specifications, and Standard Plans for the contract listed above.

I also certify that I am an official representative for \_\_\_\_\_ the manufacturer of the material listed above. Furthermore, I certify that where California test methods, physical or chemical test requirements are part of the specifications, that the manufacturer has performed the necessary quality control to substantiate this certification.

**Material Description:**

Manufacturer: _____
Model: _____
Serial Number (if applicable) _____
Quantity to be supplied: _____
Remarks: _____

Signed by: \_\_\_\_\_

Printed Name: \_\_\_\_\_

Title: \_\_\_\_\_

Company: \_\_\_\_\_

Date: \_\_\_\_\_

**City of San Diego**

**Engineering & Capital Projects Department, CMFE Division**

**NOTICE OF MATERIALS TO BE USED**

To: \_\_\_\_\_  
Resident Engineer

Date: \_\_\_\_\_, 20\_\_\_\_

You are hereby notified that the materials required for use under Contract No. \_\_\_\_\_  
for construction of \_\_\_\_\_  
\_\_\_\_\_

in the City of San Diego, will be obtained from sources herein designated.

<b>CONTRACT ITEM NO. (Bid Item)</b>	<b>KIND OF MATERIAL (Category)</b>	<b>NAME AND ADDRESS WHERE MATERIAL CAN BE INSPECTED (At Source)</b>

It is requested that you arrange for a sampling, testing, and inspection of the materials prior to delivery, in accordance with Section 4 - CONTROL OF MATERIALS of the WHITEBOOK, where it is practicable, and in accordance with your policy. It is understood that source inspection does not relieve the Contractor of full responsibility for incorporating in the work, materials that comply in all respects with the contract plans and specifications, nor does it preclude subsequent rejection of materials found to be undesirable or unsuitable.

Distribution:

Supplier

\_\_\_\_\_  
Signature of Supplier

\_\_\_\_\_  
Address

## **ELECTRONICALLY SUBMITTED FORMS**

**FAILURE TO FULLY COMPLETE AND SUBMIT ANY OF THE FOLLOWING FORMS WILL DEEM YOUR BID NON-RESPONSIVE.**

**PLANETBIDS WILL NOT ALLOW FOR BID SUBMISSIONS WITHOUT THE ATTACHMENT OF THESE FORMS**

The following forms are to be completed by the bidder and submitted (uploaded) electronically with the bid in PlanetBids.

- A. BID BOND – See Instructions to Bidders, Bidders Guarantee of Good Faith (Bid Security) for further instructions**
- B. CONTRACTOR’S CERTIFICATION OF PENDING ACTIONS**
- C. MANDATORY DISCLOSURE OF BUSINESS INTERESTS FORM**
- D. DEBARMENT AND SUSPENSION CERTIFICATION FOR PRIME CONTRACTOR**
- E. DEBARMENT AND SUSPENSION CERTIFICATION FOR SUBCONTRACTORS, SUPPLIERS AND MANUFACTURERS**

**BID BOND**

**See Instructions to Bidders, Bidder Guarantee of Good Faith  
(Bid Security)**

KNOW ALL MEN BY THESE PRESENTS,

That Palm Engineering Construction Company, Inc. as Principal, and Nationwide Mutual Insurance Company as Surety, are held and firmly bound unto The City of San Diego hereinafter called "OWNER," in the sum of **10% OF THE TOTAL BID AMOUNT** for the payment of which sum, well and truly to be made, we bind ourselves, our heirs, executors, administrators, successors, and assigns, jointly and severally, firmly by these presents.

WHEREAS, said Principal has submitted a Bid to said OWNER to perform the WORK required under the bidding schedule(s) of the OWNER's Contract Documents entitled

Torrey Pines Prospect-Coast Walk Guardrail

NOW THEREFORE, if said Principal is awarded a contract by said OWNER and, within the time and in the manner required in the "Notice Inviting Bids" enters into a written Agreement on the form of agreement bound with said Contract Documents, furnishes the required certificates of insurance, and furnishes the required Performance Bond and Payment Bond, then this obligation shall be null and void, otherwise it shall remain in full force and effect. In the event suit is brought upon this bond by said OWNER and OWNER prevails, said Surety shall pay all costs incurred by said OWNER in such suit, including a reasonable attorney's fee to be fixed by the court.

SIGNED AND SEALED, this 13th day of March, 2026

Palm Engineering Construction Company, Inc.

Nationwide Mutual Insurance Company

\_\_\_\_\_  
(Principal) (SEAL)

\_\_\_\_\_  
(Surety) (SEAL)

By:   
(Signature)

By:   
(Signature)

**Rasoul Shahbazi, President**  
(SEAL AND NOTARIAL ACKNOWLEDGEMENT OF SURETY)

**Lawrence F. McMahon, Attorney-in-Fact**



**CALIFORNIA ALL-PURPOSE ACKNOWLEDGMENT** Civil Code § 1189

A notary public or other officer completing this certificate verifies only the identity of the individual who signed the document, to which this certificate is attached, and not the truthfulness, accuracy or validity of that document.

STATE OF CALIFORNIA

County of San Diego



On 3/13/2026 before me, Sandra Figueroa, Notary Public,  
Date Insert Name of Notary exactly as it appears on the official seal

personally appeared Lawrence F. McMahon  
Name(s) of Signer(s)

who proved to me on the basis of satisfactory evidence to be the person(##) whose name(##) is/## subscribed to the within instrument and acknowledged to me that he/she/they executed the same in his/her/their authorized capacity(##), and that by his/her/their signature(##) on the instrument the person(##), or the entity upon behalf of which the person(##) acted, executed the instrument.

I certify under PENALTY OF PERJURY under the laws of the State of California that the foregoing paragraph is true and correct.

Witness my hand and official seal.

Signature [Handwritten Signature]  
Signature of Notary Public

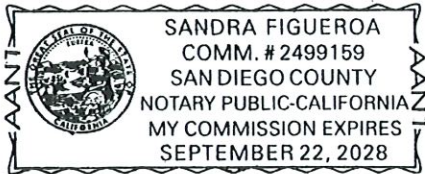

Place Notary Seal Above

**OPTIONAL**

Though the information below is not required by law, it may prove valuable to persons relying on the document and could prevent fraudulent removal and reattachment of the form to another document.

**Description of Attached Document**

Title or Type of Document: \_\_\_\_\_

Document Date: \_\_\_\_\_ Number of Pages: \_\_\_\_\_

Signer(s) Other Than Named Above: \_\_\_\_\_

**Capacity(ies) Claimed by Signer(s)**

Signer's Name: Lawrence F. McMahon

- Individual
- Corporate Officer — Title(s): \_\_\_\_\_
- Partner  Limited  General
- Attorney in Fact
- Trustee
- Guardian or Conservator
- Other: \_\_\_\_\_

**RIGHT THUMBPRINT OF SIGNER**

Top of thumb here

Signer is Representing: \_\_\_\_\_

Signer's Name: \_\_\_\_\_

- Individual
- Corporate Officer — Title(s): \_\_\_\_\_
- Partner  Limited  General
- Attorney in Fact
- Trustee
- Guardian or Conservator
- Other: \_\_\_\_\_

**RIGHT THUMBPRINT OF SIGNER**

Top of thumb here

Signer is Representing: \_\_\_\_\_

Power of Attorney

KNOW ALL MEN BY THESE PRESENTS THAT:

Nationwide Mutual Insurance Company, an Ohio corporation

hereinafter referred to severally as the "Company" and collectively as "the Companies" does hereby make, constitute and appoint:

CHRISTOPHER CONTE; DALE G HARSHAW; GEOFFREY SHELTON; JANICE MARTIN; JOHN R QUALIN; LAWRENCE F MCMAHON; MARIA GUISE; MINNA HUOVILA; RYAN WARNOCK; SARAH MYERS; TARA BACON

each in their individual capacity, its true and lawful attorney-in-fact, with full power and authority to sign, seal, and execute on its behalf on the date thereof any and all: (i) bonds and undertakings; (ii) Proposal Bonds; (ii) Letters of Surety; (iv) Consent of Surety; and (v) other obligatory instruments of similar nature, in penalties not exceeding the sum of

UNLIMITED

and to bind the Company thereby, as fully and to the same extent as if such instruments were signed by the duly authorized officers of the Company; and all acts of said Attorney pursuant to the authority given are hereby ratified and confirmed.

This power of attorney is made and executed pursuant to and by authority of the following resolution duly adopted by the board of directors of the Company:

"RESOLVED, that the president, or any vice president be, and each hereby is, authorized and empowered to appoint attorneys-in-fact of the Company, and to authorize them to execute and deliver on behalf of the Company any and all bonds, forms, applications, memorandums, undertakings, recognizances, transfers, contracts of indemnity, policies, contracts guaranteeing the fidelity of persons holding positions of public or private trust, and other writings obligatory in nature that the business of the Company may require; and to modify or revoke, with or without cause, any such appointment or authority; provided, however, that the authority granted hereby shall in no way limit the authority of other duly authorized agents to sign and countersign any of said documents on behalf of the Company."

"RESOLVED FURTHER, that such attorneys-in-fact shall have full power and authority to execute and deliver any and all such documents and to bind the Company subject to the terms and limitations of the power of attorney issued to them, and to affix the seal of the Company thereto; provided, however, that said seal shall not be necessary for the validity of any such documents."

This power of attorney is signed and sealed under and by the following bylaws duly adopted by the board of directors of the Company.

Execution of Instruments. Any vice president, any assistant secretary or any assistant treasurer shall have the power and authority to sign or attest all approved documents, instruments, contracts, or other papers in connection with the operation of the business of the company in addition to the chairman of the board, the chief executive officer, president, treasurer or secretary; provided, however, the signature of any of them may be printed, engraved, or stamped on any approved document, contract, instrument, or other papers of the Company.

IN WITNESS WHEREOF, the Company has caused this instrument to be sealed and duly attested by the signature of its officer the 23rd day of October, 2025.

[Handwritten signature of Antonio C. Albanese]

Antonio C. Albanese, Vice President of Nationwide Mutual Insurance Company

ACKNOWLEDGMENT

STATE OF OHIO COUNTY OF FRANKLIN: ss

On this 23rd day of October, 2025, before me came the above-named officer for the Company aforesaid, to me personally known to be the officer described in and who executed the preceding instrument, and he acknowledged the execution of the same, and being by me duly sworn, deposes and says, that he is the officer of the Company aforesaid, that the seal affixed hereto is the corporate seal of said Company, and the said corporate seal and his signature were duly affixed and subscribed to said instrument by the authority and direction of said Company.



Karen L. Karn  
Notary Public, State of Ohio  
No. 2018-RE-719796  
Commission Expires July 7, 2028

[Handwritten signature of Karen L. Karn]  
Notary Public  
My Commission Expires  
July 7, 2028

CERTIFICATE

I, Lezlie F. Chimienti, Assistant Secretary of the Company, do hereby certify that the foregoing is a full, true and correct copy of the original power of attorney issued by the Company; that the resolution included therein is a true and correct transcript from the minutes of the meetings of the boards of directors and the same has not been revoked or amended in any manner; that said Antonio C. Albanese was on the date of the execution of the foregoing power of attorney the duly elected officer of the Company, and the corporate seal and his signature as officer were duly affixed and subscribed to the said instrument by the authority of said board of directors; and the foregoing power of attorney is still in full force and effect.

IN WITNESS WHEREOF, I have hereunto subscribed my name as Assistant Secretary, and affixed the corporate seal of said Company this 13th day of March, 2026.

[Handwritten signature of Lezlie F. Chimienti]

Assistant Secretary

### CONTRACTOR'S CERTIFICATION OF PENDING ACTIONS

As part of its bid or proposal (Non-Price Proposal in the case of Design-Build contracts), the Bidder shall provide to the City a list of all instances within the past 10 years where a complaint was filed or pending against the Bidder in a legal or administrative proceeding alleging that Bidder discriminated against its employees, subcontractors, vendors or suppliers, and a description of the status or resolution of that complaint, including any remedial action taken.

CHECK ONE BOX ONLY.

- The undersigned certifies that within the past 10 years the Bidder has NOT been the subject of a complaint or pending action in a legal administrative proceeding alleging that Bidder discriminated against its employees, subcontractors, vendors or suppliers.
- The undersigned certifies that within the past 10 years the Bidder has been the subject of a complaint or pending action in a legal administrative proceeding alleging that Bidder discriminated against its employees, subcontractors, vendors or suppliers. A description of the status or resolution of that complaint, including any remedial action taken and the applicable dates is as follows:

DATE OF CLAIM	LOCATION	DESCRIPTION OF CLAIM	LITIGATION (Y/N)	STATUS	RESOLUTION/REMEDIAL ACTION TAKEN
N/A					

Contractor Name: Palm Engineering Construction Company, Inc.

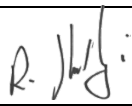
Certified By Rasoul Shahbazi Title President  
Name  
  
Signature Date 03/17/2026

**USE ADDITIONAL FORMS AS NECESSARY**

## Mandatory Disclosure of Business Interests Form

### BIDDER/PROPOSER INFORMATION

Legal Name		DBA	
Palm Engineering Construction Company, Inc.		Palm Engineering	
Street Address	City	State	Zip
7330 Opportunity Rd ste A	San Diego	CA	92111
Contact Person, Title		Phone	Fax
Rasoul Shahbazi		(619) 291-1495	None

Provide the name, identity, and precise nature of the interest\* of all persons who are directly or indirectly involved\*\* in this proposed transaction (SDMC § 21.0103).

\* The precise nature of the interest includes:

- the percentage ownership interest in a party to the transaction,
- the percentage ownership interest in any firm, corporation, or partnership that will receive funds from the transaction, the value of any financial interest in the transaction,
- any contingent interest in the transaction and the value of such interest should the contingency be satisfied, and any philanthropic, scientific, artistic, or property interest in the transaction.

\*\* Directly or indirectly involved means pursuing the transaction by:

- communicating or negotiating with City officers or employees,
- submitting or preparing applications, bids, proposals or other documents for purposes of contracting with the City,
- or directing or supervising the actions of persons engaged in the above activity.

Name	Title/Position
Rasoul Shahbazi	President
City and State of Residence	Employer (if different than Bidder/Proposer)
Chula Vista, CA 91914	Palm Engineering Construction Company, Inc.
Interest in the transaction	
100%	

Name	Title/Position
City and State of Residence	Employer (if different than Bidder/Proposer)
Interest in the transaction	

### \* Use Additional Pages if Necessary \*

Under penalty of perjury under the laws of the State of California, I certify that I am responsible for the completeness and accuracy of the responses contained herein, and that all information provided is true, full and complete to the best of my knowledge and belief. I agree to provide written notice to the Mayor or Designee within five (5) business days if, at any time, I learn that any portion of this Mandatory Disclosure of Business Interests Form requires an updated response. Failure to timely provide the Mayor or Designee with written notice is grounds for Contract termination.

Rasoul Shahbazi, President

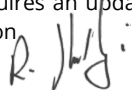

03/17/2026

Print Name, Title

Signature

Date

**Failure to sign and submit this form with the bid/proposal shall make the bid/proposal non-responsive. In the case of an informal solicitation, the contract will not be awarded unless a signed and completed Mandatory Disclosure of Business Interests Form is submitted.**

**DEBARMENT AND SUSPENSION CERTIFICATION**  
**PRIME CONTRACTOR**  
**FAILURE TO COMPLETE AND SUBMIT AT TIME OF BID SHALL RENDER BID NON-RESPONSIVE**

EFFECT OF DEBARMENT OR SUSPENSION
To promote integrity in the City's contracting processes and to protect the public interest, the City shall only enter into contracts with responsible- bidders and contractors. In accordance with San Diego Municipal Code §22.0814 (a): <i>Bidders</i> and <i>contractors</i> who have been <i>debarred</i> or <i>suspended</i> are excluded from submitting bids, submitting responses to requests for proposal or qualifications, receiving <i>contract</i> awards, executing <i>contracts</i> , participating as a <i>subcontractor</i> , employee, agent or representative of another <i>person</i> contracting with the City.

As part of its bid or proposal (Non-Price Proposal in the case of Design-Build contracts), the Bidder shall provide to the City a list of Names of the Principal Individual owner(s).

The names of all persons interested in the foregoing proposal as Principals are as follows:

NAME	TITLE
Rasoul Shahbazi	President

**IMPORTANT NOTICE:** If Bidder or other interested person is a corporation, state secretary, treasurer, and manager thereof; if a co-partnership, state true name of firm, also names of all individual co-partners composing firm; if Bidder or other interested person is an individual, state first and last names in full.

The Bidder, under penalty of perjury, certifies that, except as noted below, he/she or any person associated therewith in the capacity of owner, partner, director, officer, manager:

- Is not currently under suspension, debarment, voluntary exclusion, or determination of ineligibility by any Federal, State or local agency;
- has not been suspended, debarred, voluntarily excluded or determined ineligible by any Federal, State or local agency within the past 3 years;
- does not have a proposed debarment pending; and
- has not been indicted, convicted, or had a civil judgment rendered against it by a court of competent jurisdiction in any matter involving fraud or official misconduct within the past 3 years.

If there are any exceptions to this certification, insert the exceptions in the following space.

None.
-------

Exceptions will be considered in determining bidder responsibility. For any exception noted above, indicate below to whom it applies, initiating agency, and dates of action.

Contractor Name: Palm Engineering Construction Company, Inc.

Certified By Rasoul Shahbazi Title President

Name



Date 03/17/2026

Signature

**NOTE:** Providing false information may result in criminal prosecution or administrative sanctions.

**DEBARMENT AND SUSPENSION CERTIFICATION**  
**SUBCONTRACTORS, SUPPLIERS AND MANUFACTURERS**  
**\*TO BE COMPLETED BY BIDDER\***  
**FAILURE TO COMPLETE AND SUBMIT AT TIME OF BID SHALL RENDER BID NON-RESPONSIVE**

Names of the Principal individual owner(s)

As part of its bid or proposal (Non-Price Proposal in the case of Design-Build contracts), the Bidder shall provide to the City a list of Names of the Principal Individual owner(s) for their subcontractor/supplier/manufacturers.

Please indicate if principal owner is serving in the capacity of **subcontractor**, **supplier**, and/or **manufacturer**:

SUBCONTRACTOR                       SUPPLIER                       MANUFACTURER

NAME	TITLE
TIMOTHY MICHAEL MARTIN (PRECISION STRIPING INC)	CEO / PRESIDENT

SUBCONTRACTOR                       SUPPLIER                       MANUFACTURER

NAME	TITLE
TODD MARTIN PERRY (PERRY ELECTRIC)	RMO / CEO / PRES

SUBCONTRACTOR                       SUPPLIER                       MANUFACTURER

NAME	TITLE

SUBCONTRACTOR                       SUPPLIER                       MANUFACTURER

NAME	TITLE

Contractor Name: Palm Engineering Construction Company, Inc.

Certified By Rasoul Shahbazi Title President

Name 

Date 03/17/2026

Signature

**\*USE ADDITIONAL FORMS AS NECESSARY\*\***

# City of San Diego

CITY CONTACT: Rosa Riego, Senior Contract Specialist, Email: [RRiego@sandiego.gov](mailto:RRiego@sandiego.gov)  
Phone No. (619) 533-3426

---

## ADDENDUM A



## FOR

## TORREY PINES PROSPECT-COAST WALK GUARDRAIL

BID NO.:	<u>K-26-2448-DBB-3</u>
SAP NO. (WBS/IO/CC):	<u>B-19056</u>
CLIENT DEPARTMENT:	<u>2116</u>
COUNCIL DISTRICT:	<u>1</u>
PROJECT TYPE:	<u>IE</u>
STATE AID PROJECT NO.:	<u>HSIPSL-5004(213)</u>

---

### **BID DUE DATE:**

**2:00 PM  
MARCH 17, 2026**

**CITY OF SAN DIEGO'S ELECTRONIC BIDDING SITE, PLANETBIDS**

<http://www.sandiego.gov/cip/bidopps/>

**A. CHANGES TO CONTRACT DOCUMENTS**

The following changes to the Contract Documents are hereby made effective as though originally issued with the bid package. Bidders are reminded that all previous requirements to this solicitation remain in full force and effect.

THE SUBMITTAL DATE FOR THIS PROJECT HAS BEEN **EXTENDED AS STATED ON THE COVER PAGE.**

Elif E. Cetin, Director  
Engineering & Capital Projects Department

Dated: *February 20, 2026*  
San Diego, California

EEC/AJ/ker

# City of San Diego

**CITY CONTACT:** Rosa Riego, Senior Contract Specialist, Email: [RRiego@sandiego.gov](mailto:RRiego@sandiego.gov)  
Phone No. (619) 533-3426

---

## ADDENDUM B



## FOR

## TORREY PINES PROSPECT-COAST WALK GUARDRAIL

BID NO.: K-26-2448-DBB-3  
SAP NO. (WBS/IO/CC): B-19056  
CLIENT DEPARTMENT: 2116  
COUNCIL DISTRICT: 1  
PROJECT TYPE: IE  
STATE AID PROJECT NO.: HSIPSL-5004(213)

---

### **BID DUE DATE:**

**2:00 PM  
MARCH 17, 2026**

**CITY OF SAN DIEGO'S ELECTRONIC BIDDING SITE, PLANETBIDS**

<http://www.sandiego.gov/cip/bidopps/>

## ENGINEER OF WORK

The Engineering Specifications and Special Provisions contained herein have been prepared by or under the direction of the following Registered Engineer:



3/6/26

Seal:



1) Registered Engineer

Date



03/06/2026

Seal:

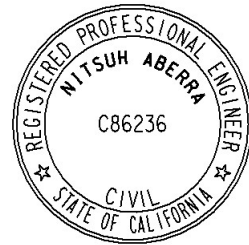

2) For City Engineer

Date

## **A. CHANGES TO CONTRACT DOCUMENTS**

The following changes to the Contract Documents are hereby made effective as though originally issued with the bid package. Bidders are reminded that all previous requirements to this solicitation remain in full force and effect.

## **B. NOTICE INVITING BIDS**

1. To Item **3., ESTIMATED CONSTRUCTION COST**, page 5, **DELETE** in its entirety and **SUBSTITUTE** with the following:
  3. **ESTIMATED CONSTRUCTION COST:** The City's estimated construction cost for this project is **\$1,480,000.00**.

## **C. SUPPLEMENTARY SPECIAL PROVISIONS**

1. To **SECTION 1 - GENERAL, TERMS, DEFINITIONS, ABBREVIATIONS, UNITS OF MEASURE, AND SYMBOLS, 1-2, TERMS AND DEFINITIONS**, page 41, **Normal Working Hours: DELETE** in its entirety and **SUBSTITUTE** with the following:

**Normal Working Hours:** Normal Working Hours shall be **7:00 PM to 3:00 AM, Monday through Friday**, inclusive. Saturdays, Sundays, and City Holidays are excluded. Unless otherwise specified on the Traffic Control Permits. No work shall be allowed on the day of the La Jolla Half Marathon, May 16, 2026, Law Enforcement Torch Run for Special Olympics, Date TBD, CAF (Challenged Athletes Foundation) Community Challenge Weekend, Date TBD and Bike Multiple Sclerosis (MS), Bay to Bay, Date TBD.

2. To **SECTION 3 - CONTROL OF WORK, ADD** the following:

**3-12-3 NOISE CONTROL.** To the "GREENBOOK", **ADD** the following:

Noise levels from project-related construction activities shall be controlled to limit excessive noise beyond the project footprint and the following measures shall be required of the contractor to reduce construction noise generated by construction and construction equipment. All cost associated with noise

reduction measures shall be included in the various items of work.

- a. Construction equipment to be properly outfitted and maintained with manufacturer-recommended noise-reduction devices.
- b. All internal combustion engines to be equipped with mufflers in good repair and are subject to the City Noise Control Ordinance.
- c. Diesel equipment to be operated with closed engine doors and equipped with factory-recommended mufflers.
- d. Mobile or fixed "package" equipment (e.g., arc-welders and air compressors) to be equipped with shrouds and noise control features that are readily available for that type of equipment.
- e. Electrically powered equipment to be used instead of pneumatic or internal-combustion powered equipment, where feasible.
- f. Unnecessary idling of internal combustion engines (e.g., in excess of 5 minutes) to be prohibited.
- g. Material stockpiles and mobile equipment staging, parking, and maintenance areas to be located as far as practicable from noise sensitive receptors.
- h. The use of noise-producing signals, including horns, whistles, alarms, and bells, shall be for safety warning purposes only.
- i. Temporary noise attenuation barriers shall be included as directed by the Resident Engineer and City Project Biologist per Section 7-3.1

3. To **SECTION 7 - MEASUREMENT AND PAYMENT, ADD** the following:

**7-3.1 General.** To the "WHITEBOOK", ADD the following:

4. Temporary Noise Attenuation Barrier – Temporary Noise Attenuation Barrier shall be made of plywood, 6 feet in height and shall be placed along project site

at locations determined by the Resident Engineer and City Project Biologist. Full compensation for furnishing all labor, materials, including, but not limited to, plywood, anchoring, securing, bracing and reinforcement and all other work necessary to complete in place, and as directed by the Resident Engineer and City Project Biologist, and shall be included in the Contract unit price paid per Temporary Noise Attenuation Barrier and no additional compensation shall be allowed therefore.

4. To **SECTION 300 – EARTHWORK, 300-1.1, General.**, page 60, item 10, Subitem “c.”, **DELETE** in its entirety and **SUBSTITUTE** with the following:
  - c. Removal of trees, shrubs, stumps, trash, debris barricade, vegetation in the pavement cracks, curb lines, gutter, or behind the existing k-rail whether or not specifically indicated on the Plans or otherwise shown to be protected or relocated, which is not included in any other bid item.
  
5. To **SECTION 300 – EARTHWORK, 300-1.1, General.**, page 61, item 10, **ADD** the following:
  - m. Sawcutting, removal, and disposal of portions of existing concrete pads or fence posts, and light footings conflicting with the proposed improvements.
  
6. To **SECTION 303 – CONCRETE AND MASONRY CONSTRUCTION**, page 67, **ADD** the following:

**303-1.12 Payment.** To the “GREENBOOK”, ADD the following:

  1. Gravity Wall Type A - Full compensation for furnishing all labor, materials, including, but not limited to, concrete, reinforcement, joints, finishing, curing, structural excavation, backfill, subgrade preparation, anti-graffiti coating and all other work necessary to complete in place, as shown on plans and Specifications and as directed by the Engineer, and shall be included in the Contract unit price paid per Cubic Foot for Gravity Wall, Type A (standard

plan specified) and no additional compensation shall be allowed therefore.

7. To **SECTION 402 – UTILITIES, 402-4, Relocation**, page 72, **DELETE** in its entirety and **SUBSTITUTE** with the following:

**402-4 Relocation.** To the “GREENBOOK”, ADD the following:

Notify Utility prior to excavating within 10 feet of utility facilities.

The construction schedule will need to account for utility relocation activities. You must coordinate with the utility companies for the relocations. Details regarding the utilities and type of work are described in detail in the table below for work shown on plan sheets 0101250-01-D and 0101250-11-D through 0101250-15-D.

Utility	Contact	Lead Time	Work Window	Stage of construction prior to utility work	Type of work to be conducted by utilities
SDG&E Electrical	SDG&E Project Manager Chuck Haas <a href="mailto:Chaas@sdge.com">Chaas@sdge.com</a> 619-540-4010	8-12 weeks	Adjusting a single lid requires about 1 to 2 days of work	Sidewalk installation	Adjust pull box and lid to grade
AT&T	Jeffrey Espiritu <a href="mailto:je4541@att.com">je4541@att.com</a> 858.531.6386	2 weeks	1-3 days; depending on whether box needs to be raised in phases	If new curb is set ideally or if new elevation is staked	Adjust pull box and lid to grade

8. To page 74, **ADD** the following.

**SECTION 801 -INSTALLATION**

**801-9 Payment** To the "WHITEBOOK", ADD following:

4. Payment for relocation all existing private irrigation PVC lines and irrigation heads conflicting the proposed work shall be included in the Bid item for "Irrigation System Relocation". Relocation of irrigation heads shall be 4" away from the back of sidewalk or as directed by the Engineer. Prior to relocation of irrigation system, contractor shall coordinate with the property owner to confirm relocation location.

**D. ADDITIONAL CHANGES**

1. The following are additional changes to the Line Items in the PlanetBids Tab:

For clarity where applicable, **ADDITIONS**, if any, have been **Underlined** and **DELETIONS**, if any, have been **Stricken out**.

Section	Item Code	Description	UoM	Quantity	Payment Reference
Main Bid	237110	Meter Box	EA	<del>7</del> <u>10</u>	306-15.8
Main Bid	237310	Pedestrian Barricade	EA	<del>4</del> <u>2</u>	701-2
<u>Main Bid</u>	<u>238110</u>	<del>Concrete Gravity Wall</del>	<u>CF</u>	<u>60</u>	<u>303-1.12</u>
<u>Main Bid</u>	<u>561730</u>	<del>Irrigation System Relocation</del>	<u>LS</u>	1	<u>801-9</u>
<u>Main bid</u>	<u>237310</u>	<del>Temporary Noise Attenuation Barrier</del>	<u>LF</u>	<u>300</u>	<u>7-3.1</u>

## E. PLANS

1. To Drawing Numbers 010250-01-D and 010250-T1-D through 010250-T2-D, **DELETE** in their entirety and **REPLACE** with **ADDENDUM B** Drawing Numbers 010250-01-D and 010250-T1-D through 010250-T2-D.
2. To Drawing Numbers 010250-02-D through 010250-06-D, **DELETE** in their entirety.
3. **ADD ADDENDUM B** Drawing Numbers 010250-11-D through 010250-15-D.
4. For the above changes, see pages 9 through 21 of this Addendum.

Elif E. Cetin, Director  
Engineering & Capital Projects Department

Dated: *March 6, 2026*  
San Diego, California

EEC/AJ/yk

**CONTRACTOR'S RESPONSIBILITIES**

1. PURSUANT TO SECTION 4216 OF THE GOVERNMENT CODE, AT LEAST 2 WORKING DAYS PRIOR TO EXCAVATION, YOU MUST CONTACT THE REGIONAL NOTIFICATION CENTER (E.G. UNDERGROUND SERVICE ALERT OF SOUTHERN CALIFORNIA) AND OBTAIN AN INQUIRY IDENTIFICATION NUMBER.
2. NOTIFY SDG&E AT LEAST 30 WORKING DAYS PRIOR TO EXCAVATING WITHIN 10' OF SDG&E UNDERGROUND HIGH VOLTAGE TRANSMISSION POWER LINES. (I.E., 69 KV & HIGHER)
3. THE LOCATIONS OF EXISTING BUILDINGS AS SHOWN ON THE PLAN ARE APPROXIMATE.
4. STORM DRAIN INLETS SHALL REMAIN FUNCTIONAL AT ALL TIMES DURING CONSTRUCTION.
5. UNLESS OTHERWISE NOTED AS PREVIOUSLY POTHOLED (PH), ELEVATIONS SHOWN ON THE PROFILE FOR EXISTING UTILITIES ARE BASED ON A SEARCH OF THE AVAILABLE RECORD INFORMATION ONLY AND ARE SOLELY FOR THE CONTRACTOR'S CONVENIENCE. THE CITY DOES NOT GUARANTEE THAT IT HAS REVIEWED ALL AVAILABLE DATA. THE CONTRACTOR SHALL POTHOLE ALL EXISTING UTILITIES EITHER SHOWN ON THE PLANS OR MARKED IN THE FIELD IN ACCORDANCE WITH THE SPECIFICATIONS SECTION 402-UTILITIES.
6. EXISTING UTILITY CROSSING AS SHOWN ON THE PLANS ARE APPROXIMATE AND ARE NOT REPRESENTATIVE OF ACTUAL LENGTH AND LOCATION OF CONFLICT AREAS. SEE PLAN VIEW.
7. CONTRACTOR TO COORDINATE WITH PUD AND FIRE DEPARTMENT FOR SHUT DOWN OF WATER MAIN AND FOR RELOCATION OF WATER SERVICES AND FIRE SERVICE.

**CONSTRUCTION STORM WATER PROTECTION NOTES**

1. TOTAL SITE DISTURBANCE AREA (ACRES) 0.11 ACRES  
HYDROLOGIC UNIT & WATERSHED PENASQUITOS HU/ ASBS - MISSION BAY WATERSHED  
HYDROLOGIC SUBAREA NAME & NO. SCRIPPS HSA -906.30
2. THE CONTRACTOR SHALL COMPLY WITH THE REQUIREMENTS OF THE
  - MINOR WPCP  
THE PROJECT IS SUBJECT TO MUNICIPAL SEPARATE STORM SEWER SYSTEM (MS4) PERMIT NO. R9-2013-0001 AS AMENDED BY R9-2015-0001 AND R9-2015-0100
  - WPCP  
THE PROJECT IS SUBJECT TO MUNICIPAL SEPARATE STORM SEWER SYSTEM (MS4) PERMIT NO. R9-2013-0001 AS AMENDED BY R9-2015-0001 AND R9-2015-0100
  - SWPPP  
THE PROJECT IS SUBJECT TO MUNICIPAL SEPARATE STORM SEWER SYSTEM (MS4) PERMIT NO. R9-2013-0001 AS AMENDED BY R9-2015-0001 AND R9-2015-0100 AND CONSTRUCTION GENERAL PERMIT (CGP) ORDER 2022-0057-DWQ

TRADITIONAL: RISK LEVEL  1  2  3   
LUP: RISK TYPE  1  2  3

**PERMANENT STORM WATER BMP CATEGORY:**

- PRIORITY DEVELOPMENT PROJECT
- STANDARD DEVELOPMENT PROJECT
- PDP EXEMPT
- NOT SUBJECT TO PERMANENT STORM WATER REQUIREMENTS

**ABBREVIATIONS**

ABAND	ABANDON	DWG	DRAWING	KV	KILOVOLTS	POR	PORTION
ABAND'D	ABANDONED	DB	DIRECT BURIED	LA	LATERAL	PRVT	PRIVATE
AB	AGGREGATE BASE	DI	DUCTILE IRON	LT	LEFT	RDCR	REDUCER
AC	ASBESTOS CEMENT PIPE/ ASPHALT CONCRETE	EB	ENCASED BURIED	MJ	MECHANICAL JOINT	RCR	REINFORCED CONCRETE PIPE
AHD	AHEAD	EG	EXISTING GROUND	MTS	SAN DIEGO METROPOLITAN TRANSIT SYSTEM	RT	RIGHT
ASSY	ASSEMBLY	EL	ELEVATION	MTD	MULTIPLE TELEPHONE DUCT	R/W	RIGHT OF WAY
BC	BEGIN CURVE	ELEC	ELECTRIC	N/O	NORTH OF	S	SURVEY LINE
BFV	BUTTERFLY VALVE	EUG	ELECTRIC UNDERGROUND	NOC	NOTICE OF COMPLETION	SD&AE	SAN DIEGO & ARIZONA EASTERN RAILROAD
BK	BACK	EP	END POINT	NTP	NOTICE TO PROCEED	SDTI	SAN DIEGO TROLLEY INC.
BLK	BLOCK	EX, EXIST	EXISTING	OVHD	OVER HEAD	S/O	SOUTH OF
BP	BEGIN POINT	E/O	EAST OF	PVC	POLYVINYL CHLORIDE	SO	STUB OUT
BTWN	BETWEEN	F	FLANGE	POB	POINT OF BEGINNING	S/O	SOUTH OF
CATV	CABLE TV	FH	FIRE HYDRANT	PCC	POINT OF COMPOUND CURVE/ PORTLAND CEMENT CONCRETE	SWR	SEWER SERVICE
CI	CAST IRON PIPE	FS	FINISHED SURFACE	PC	POINT OF CURVE	SVC	SERVICE
CL	CENTER LINE	GV	GATE VALVE	POE	POINT OF END	TEL	TELEPHONE
COND	CONCRETE LINED CONDUIT	HDPE	HIGH-DENSITY POLYETHYLENE	PRC	POINT OF REVERSE CURVATURE	TOP/TP	TOP OF PIPE
CONT	CONTINUED	HP	HIGH PRESSURE	PT	POINT OF TANGENT	UNK	UNKNOWN
CONTR	CONTRACTOR	IE	INVERT ELEVATION	PRQP	PROPOSED PROPERTY LINE	VC	VITRIFIED CLAY PIPE
COM	COMMUNICATIONS			PL	PROPERTY LINE	WM	WATER METER
						WTR	WATER
						W/O	WEST OF

**EXISTING STRUCTURES**

EX WATER MAIN & VALVES	---	EX GROUND LINE (PROFILE)	=====
EX WATER METER	---[M]---	EX TRAFFIC SIGNAL	OK TS
EX FIRE HYDRANT	---[H]---	EX CONCRETE K-RAIL BARRIER	====
EX SEWER MAIN & MANHOLES	---[S]---	EX CHAINLINK FENCE	---X---
EX DRAINS	====	EX ROAD CENTERLINE	-----
EX AC PAVEMENT (PROFILE)	=====	EX SIDEWALK	=====
EX CONCRETE PAVEMENT (PROFILE)	=====	EX CURB & GUTTER	=====
EX STREET LIGHT	---[L]---	EX PAVEMENT SECTION PER CORING REPORT	=====
GAS MAIN	---G---		
ELEC. COND., TEL. COND., CATV, ATT, OH	E---T---COM---ATT---OH		
EX ELECTRICAL PULL BOX	[EB]		
EX TRAFFIC PULL BOX	[TB]		
EX COMMUNICATION PEDESTAL	[P]		
EX SIGN	[S]		
EX CONTOUR	---(100)---		
EX ELEVATION	---(100FS)---		

CHANGE	DATE	AFFECTED OR ADDED SHEET NUMBERS	APPROVAL NO.
<sup>B</sup>	3/4/26	SHEETS 2,3,4,5,6,T1,T2,T11,12,13,14, AND 15	

**WARNING**

IF THIS BAR DOES NOT MEASURE 1" THEN DRAWING IS NOT TO SCALE.

# TORREY PINES ROAD PROSPECT-COAST WALK GUARDRAIL

## STATE-AID ID: HSIPSL-5004(213)

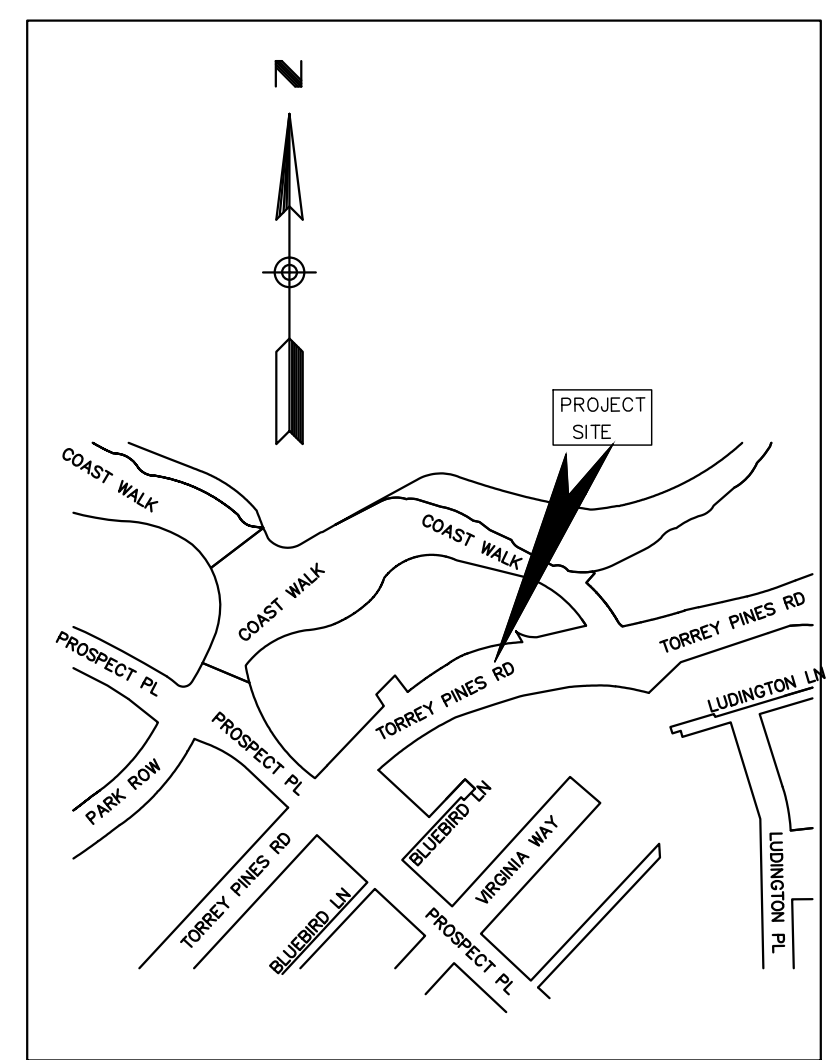

**KEY MAP**  
NO SCALE

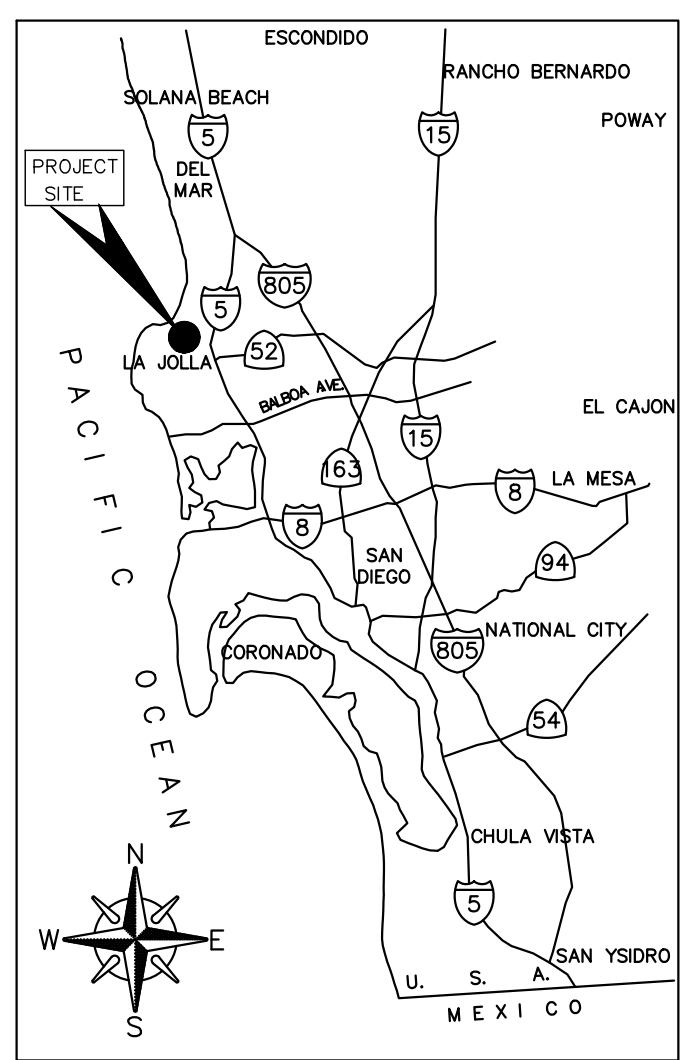

**VICINITY MAP**  
NOT TO SCALE

**SHEET INDEX**

SHEET NO.	DISCIPLINE CODE	TITLE	LIMITS
1	G-1	COVER SHEET	N TORREY PINES RD FROM COAST WALK TO PROSPECT PL
2	D-1	EXISTING CONDITIONS AND DEMOLITION PLAN	N TORREY PINES RD FROM COAST WALK TO PROSPECT PL
3	C-1	DETAILS AND CROSS SECTIONS	N TORREY PINES RD FROM COAST WALK TO PROSPECT PL
4	C-2	WATER SERVICE RELOCATION DETAILS	N TORREY PINES RD FROM COAST WALK TO PROSPECT PL
5	G-3	IMPROVEMENT PLAN	N TORREY PINES RD FROM COAST WALK TO PROSPECT PL
6	C-4	UTILITY PLAN	N TORREY PINES RD FROM COAST WALK TO PROSPECT PL
7	C-5	MONUMENT PRESERVATION PLAN	N TORREY PINES RD FROM COAST WALK TO PROSPECT PL
8	C-6	BMP PLAN	N TORREY PINES RD FROM COAST WALK TO PROSPECT PL
9	T-1	TITLE SHEET	N TORREY PINES RD FROM COAST WALK TO PROSPECT PL
10	T-2	SIGNING AND STRIPING PLAN	N TORREY PINES RD FROM PROSPECT PL TO COAST WALK
T1	TC-1	TRAFFIC CONTROL PLAN WORKING HOURS	N TORREY PINES RD FROM PROSPECT PL TO AMALFI ST
T2	TC-2	TRAFFIC CONTROL PLAN WORKING HOURS W/ SIDEWALK CLOSURE	N TORREY PINES RD FROM PROSPECT PL TO AMALFI ST
T3	TC-3	TRAFFIC CONTROL PLAN NON-WORKING HOURS	N TORREY PINES RD FROM PROSPECT PL TO AMALFI ST
11	D-1	EXISTING CONDITIONS AND DEMOLITION PLAN	N TORREY PINES RD FROM COAST WALK TO PROSPECT PL
12	C-1	DETAILS AND CROSS SECTIONS	N TORREY PINES RD FROM COAST WALK TO PROSPECT PL
13	C-2	WATER SERVICE RELOCATION DETAILS	N TORREY PINES RD FROM COAST WALK TO PROSPECT PL
14	C-3	IMPROVEMENT PLAN	N TORREY PINES RD FROM COAST WALK TO PROSPECT PL
15	C-4	UTILITY PLAN	N TORREY PINES RD FROM COAST WALK TO PROSPECT PL

**DECLARATION OF RESPONSIBLE CHARGE**

I HEREBY DECLARE THAT I AM THE ENGINEER OF WORK FOR THIS PROJECT AND THAT I HAVE EXERCISED RESPONSIBLE CHARGE OVER THE DESIGN OF THE PROJECT AS DEFINED IN SECTION 6703 OF THE BUSINESS AND PROFESSIONS CODE AND THAT THE DESIGN IS CONSISTENT WITH CURRENT STANDARDS. I UNDERSTAND THAT THE CHECK OF PROJECT DRAWINGS AND SPECIFICATIONS BY THE CITY OF SAN DIEGO IS CONFINED TO A REVIEW ONLY AND DOES NOT RELIEVE ME, AS ENGINEER OF WORK, OF MY RESPONSIBILITIES FOR PROJECT DESIGN.

*Lawrence P. Thornburgh*  
LAWRENCE P. THORNBURGH R.C.E. NO. 49795 DATE OF SIGNING 12/11/25

**DISCIPLINE CODE**

- G GENERAL
- D DEMOLITION
- C CIVIL
- TC TRAFFIC CONTROL
- T TRAFFIC

**FIELD DATA**

**BENCHMARK:**  
NWPB TORREY PINES RD & PRINCESS ST (PT#50)  
ELEV. 92.029 MSL, BASED ON NGVD 29 FEET AS SHOWN IN THE CITY OF SAN DIEGO BENCH BOOK

**FIELD NOTES:**  
BASIS OF BEARINGS / COORDINATES:  
THE BASIS OF BEARINGS FOR THIS PROJECT WAS DERIVED FROM A PREVIOUS STATIC GPS SURVEY USING R.O.F. S. 14492 NAD 83 FEET, ZONE 6 (EPOCH 1991.35), UTILIZING RTK/GPS FIELD PROCEDURES WITH A CALVRS BASE STATION BROADCAST OF 2015 AND CONSTRAINING TO GPS 17 (PT#20017) AND GPS 135, I.E. N 75°05'45" W.

**REFERENCES:**  
SUBDIVISION MAP 352, 976  
CORNER RECORD 2005, 6124, 8367, 8676, 9632, 11684, 13966, 22644, 30165, 33298, 35810, 37011, 38207, 39005, 42025, 43092, 43165  
PARCEL MAP 11844, 16353, 17819, 18446  
RECORD OF SURVEY 3063, 11773, 14019, 14560, 14675, 14794, 17822, 22848  
PRIVATE SURVEY 236, 1062, 1065, 1066  
CITY DRAWING 5099-B, 10111-B, 6684-D, 13369-D, 22552-D, 8993-A-L  
ADJOINING JOB B-17064, PIPELINE REHAB AP-1, O'DAY, 04/10/2018, 246-1689  
TOPOGRAPHY SOURCE: WBS: B19056 DATED: 06/23/20 CHIEF: C. PILKINTON

**WORK TO BE DONE**

INSTALLATION OF APPROXIMATELY 420 FEET OF CALIFORNIA ST-75B BRIDGE RAIL, END BLOCKS, AND CRASH CUSHIONS ON THE NORTH SIDE OF TORREY PINES ROAD BETWEEN PROSPECT PLACE AND COAST WALK. PROJECT INCLUDES REPLACEMENT OF SIDEWALK AND CURB AND GUTTER, UTILITY RELOCATIONS, ROADWAY PAVING, AND TRAFFIC STRIPING AND SIGNAGE.

**STANDARD SPECIFICATIONS:**

DOCUMENT NO.	DESCRIPTION
ECPI010122-01	STANDARD SPECIFICATIONS FOR PUBLIC WORKS CONSTRUCTION (GREENBOOK), 2021 EDITION
ECPI010122-02	CITY OF SAN DIEGO STANDARD SPECIFICATIONS FOR PUBLIC WORKS CONSTRUCTION (WHITEBOOK), 2021 EDITION
PWPI010119-04	CITYWIDE COMPUTER AIDED DESIGN AND DRAFTING (CADD) STANDARDS, 2018 EDITION
EPCD032324-07	CALIFORNIA DEPARTMENT OF TRANSPORTATION MANUAL OF UNIFORM TRAFFIC CONTROL DEVICES REVISION 9 (CA MUTCD REV 9), 2014 EDITION
EPCD092023-05	CALIFORNIA DEPARTMENT OF TRANSPORTATION (CALTRANS) STANDARD SPECIFICATIONS, 2023 EDITION

**STANDARD DRAWINGS:**

DOCUMENT NO.	DESCRIPTION
ECPI010122-03	CITY OF SAN DIEGO STANDARD DRAWINGS, 2021 EDITION
EPCD092023-06	CALTRANS STANDARD PLANS, 2023 EDITION

**STREET CLASSIFICATION**

STREET NAME: TORREY PINES RD  
MAJOR, ADT=54,360

**REFERENCE:**

- MAP NO. DRAWING NO. SUBDIVISION MAP 352, 976
- 5099-B, 10111-B, 6684-D, 13369-D, 22552-D, 28592-D, 30862-D
- 8993-A-L

**LEGEND**

IMPROVEMENTS	STANDARD DRAWINGS	SYMBOL
SIDEWALK	SDG-109, SDG-155, SDG-156, G-10	[Symbol]
6" CURB & GUTTER TYPE 'G'	SDG-151, SDG-156	[Symbol]
ST-75B BRIDGE RAIL	ST-75B CALTRANS STD B11-201, B11-202	[Symbol]
CRASH CUSHION	TAU-M OR APPROVED EQUAL	[Symbol]
SAWCUT LINE		[Symbol]
GRADE BREAK		[Symbol]
GRIND AND VARIABLE OVERLAY	SDG-106 TYPE B	[Symbol]
AC PAVEMENT SECTION	SDG-113 SCHEDULE J	[Symbol]
PROPOSED SLOPE	X.XX%	[Symbol]
PROPOSED FENCE	X	[Symbol]
PROPOSED DAYLIGHT LINE		[Symbol]

\*FOR ADDITIONAL SYMBOLS SEE TRAFFIC CONTROL SHEETS

G-1

**PLANS FOR THE CONSTRUCTION OF TORREY PINES ROAD PROSPECT-COAST WALK GUARDRAIL STATE-AID ID: HSIPSL-5004(213) COVER SHEET**

CITY OF SAN DIEGO, CALIFORNIA ENGINEERING & CAPITAL PROJECTS DEPARTMENT (SHEET 1 OF 15 SHEETS)		WBS <u>B-19056</u>	
APPROVED FOR CITY ENGINEER NITSUH ABERRA PRINT DCE NAME	DATE 12/15/2025 C86236 RCE#	SUBMITTED BY NAZIE MANSURY PROJECT MANAGER	CHECKED BY RHEA VIDA PROJECT ENGINEER
DESCRIPTION	BY	APPROVED	DATE FILMED
ORIGINAL	LT/VC	[Signature]	12/15/25
<sup>B</sup> ADDENDUM B	LT/VC	[Signature]	03/08/26
CONTRACTOR INSPECTOR		NTP DATE	0101250-01-D
		NOC DATE	

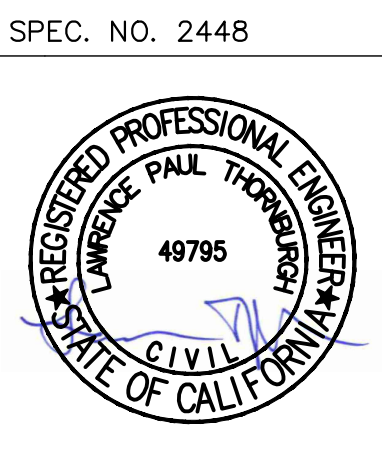

**CONSULTANT**

**Nasland** Civil Engineering  
Surveying  
Land Planning

T (658) 292-7770  
4740 Ruffner Street  
San Diego, CA 92111  
nasland.com

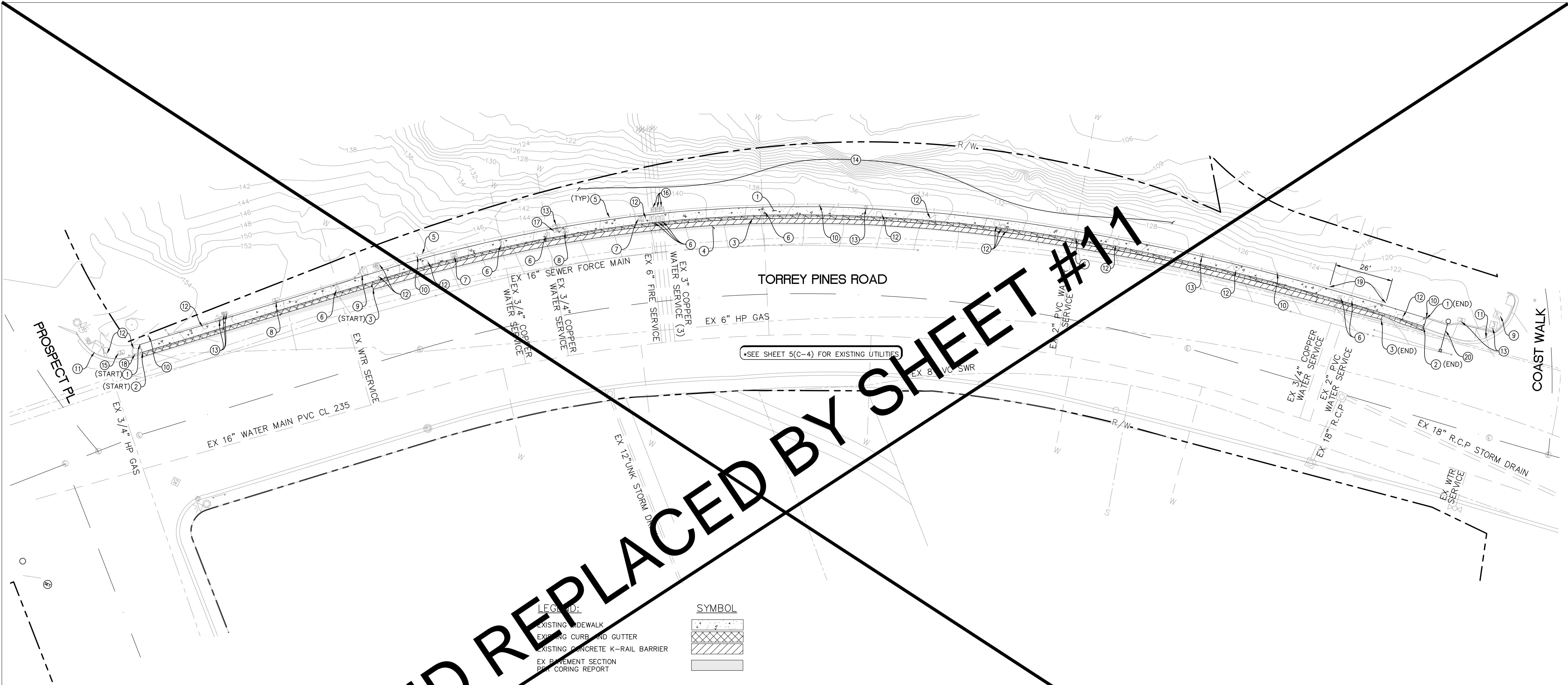

VOID REPLACED BY SHEET #11

EXISTING CONDITIONS AND DEMOLITION NOTES

- ① REMOVE EXISTING SIDEWALK.
- ② REMOVE EXISTING CURB AND GUTTER.
- ③ REMOVE EXISTING TEMPORARY CONCRETE K-RAIL BARRIER.
- ④ REMOVE EXISTING AC/PCC. WIDTH VARIES.
- ⑤ EXISTING CHAIN LINK FENCE TO REMAIN AND BE PROTECTED IN PLACE.
- ⑥ EXISTING WATER METER BOX AND LID TO BE PROTECTED IN PLACE.
- ⑦ EXISTING TRAFFIC SIGNAL PULLBOX TO REMAIN AND BE ADJUSTED TO GRADE.
- ⑧ EXISTING ELECTRICAL PULLBOX TO BE ADJUSTED TO GRADE BY SDGE.
- ⑨ EXISTING ELECTRICAL VAULT TO REMAIN AND BE PROTECTED IN PLACE.
- ⑩ EXISTING SIGN TO REMAIN AND BE PROTECTED IN PLACE. REFER TO SHEET T-2.
- ⑪ EXISTING CURB RAMP TO REMAIN AND BE PROTECTED IN PLACE.
- ⑫ EXISTING SURVEY MONUMENT TO REMAIN AND BE PROTECTED IN PLACE.
- ⑬ EXISTING COMMUNICATION VAULT TO REMAIN AND BE PROTECTED IN PLACE.
- ⑭ EXISTING LANDSCAPING AND IRRIGATION TO REMAIN AND BE PROTECTED IN PLACE.
- ⑮ EXISTING ELECTRICAL PULLBOX TO REMAIN AND BE PROTECTED IN PLACE.
- ⑯ EXISTING BACKFLOW PREVENTER TO REMAIN AND BE PROTECTED IN PLACE.
- ⑰ REMOVE TELEPHONE PULLBOX BOX AND LID AND REPLACE IN KIND AS NEEDED BY ATT.
- ⑱ EXISTING PEDESTRIAN BARRICADE TO BE PROTECTED IN PLACE.
- ⑲ REMOVE PORTION OF EXISTING 4' HIGH BLACK VINYL COATED CHAINLINK FENCE.
- ⑳ EXISTING STREET LIGHT TO REMAIN AND BE PROTECTED IN PLACE.

NOTES: CONTRACTOR TO POTHOLE AND VERIFY LOCATION AND DEPTH OF ALL FACILITIES PRIOR TO EXCAVATION

LEGEND:

SYMBOL	DESCRIPTION
[Pattern]	EXISTING SIDEWALK
[Pattern]	EXISTING CURB AND GUTTER
[Pattern]	EXISTING CONCRETE K-RAIL BARRIER
[Pattern]	EX PAVEMENT SECTION PER CORING REPORT

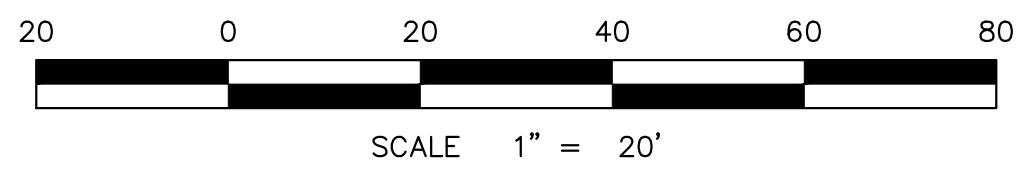

PLANS FOR THE CONSTRUCTION OF TORREY PINES ROAD PROSPECT-COAST WALK GUARDRAIL STATE-AID ID: HSIPL-5004(213) EXISTING CONDITIONS AND DEMOLITION PLAN

CITY OF SAN DIEGO, CALIFORNIA ENGINEERING & CAPITAL PROJECTS DEPARTMENT SHEET 2 OF 10 SHEETS WBS B-19056

APPROVED FOR CITY ENGINEER NITSUH ABERRA PRINT DCE NAME	DATE 12/15/2025 C86236 RCE#	SUBMITTED BY NAZIE MANSURY PROJECT MANAGER		
DESCRIPTION	BY	APPROVED	DATE	FILMED
ORIGINAL	LT/VC		12/15/25	
ADDENDUM B	NE		03/06/26	
		CHECKED BY RHEA VIDA PROJECT ENGINEER	SEE EACH SHEET CCS27 COORDINATE	
		SEE EACH SHEET CCS83 COORDINATE		

SPEC. NO. 2448

CONSULTANT

**Nasland** Civil Engineering  
Surveying  
Land Planning

T (858) 292-7770  
4740 Ruffner Street  
San Diego, CA 92111  
nasland.com

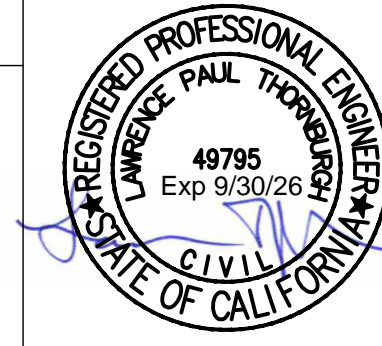

CONTRACTOR INSPECTOR: \_\_\_\_\_ NTP DATE: \_\_\_\_\_ NOC DATE: \_\_\_\_\_

0101250-02-D

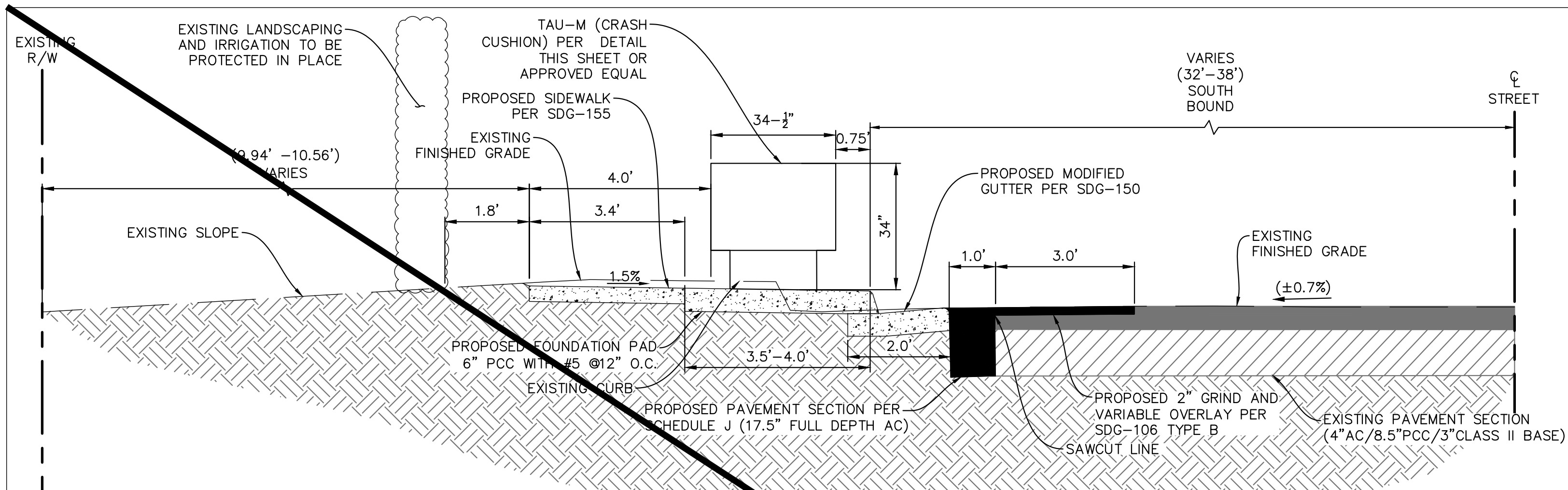

**TORREY PINES ROAD  
TAU-M DETAIL  
SECTION A-A**  
(STA: 11+09.30-11+24.60)  
NOT TO SCALE

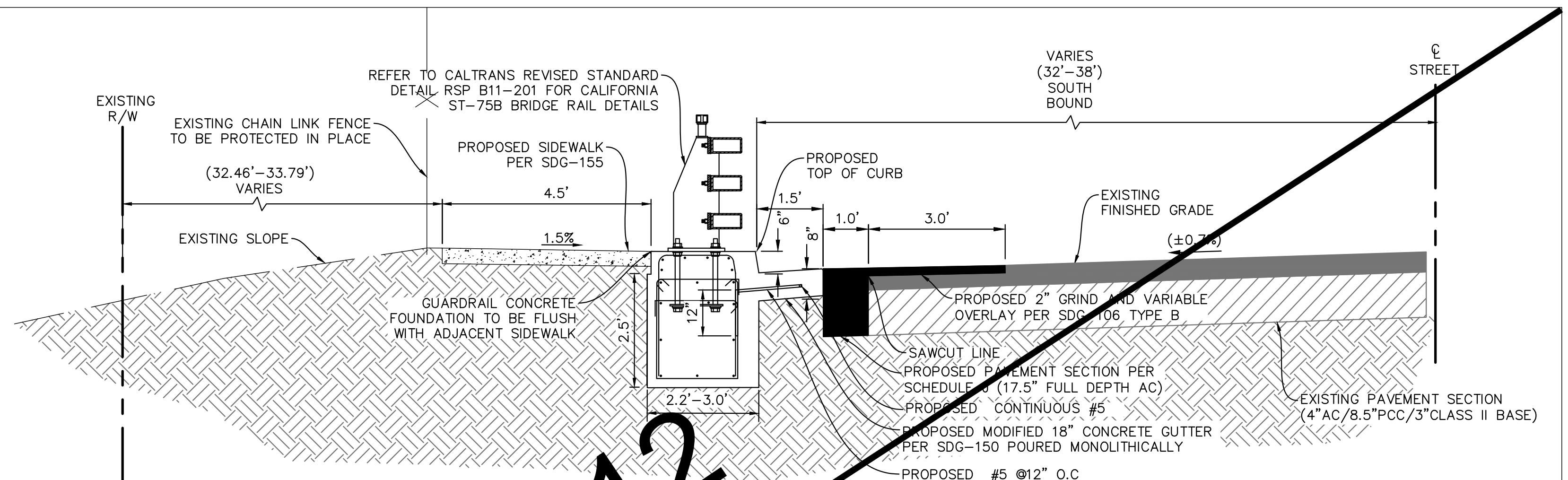

**TORREY PINES ROAD  
MODIFIED ST-75B BRIDGE RAIL FOOTING TRANSITION  
SECTION B-B**  
(STATIONS 11+28.60-11+51.57 AND 15+28.12-15+48.10)  
NOT TO SCALE

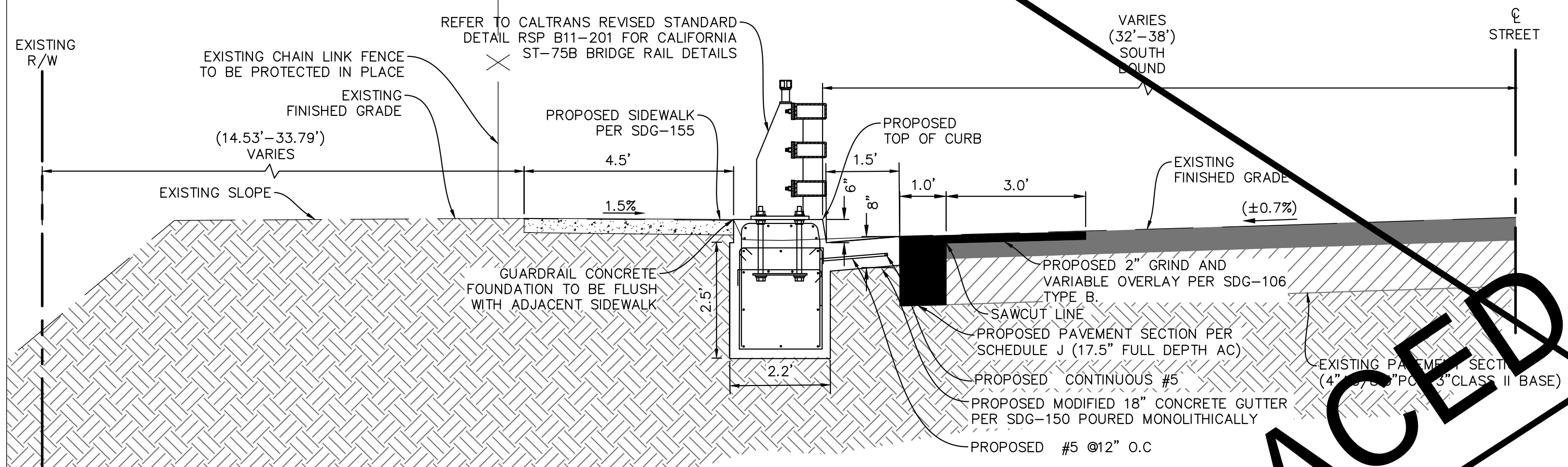

**TORREY PINES ROAD  
MODIFIED ST-75B BRIDGE RAIL WITH GUTTER DETAIL  
SECTION C-C**  
(STA: 11+51.57-15+28.12)  
NOT TO SCALE

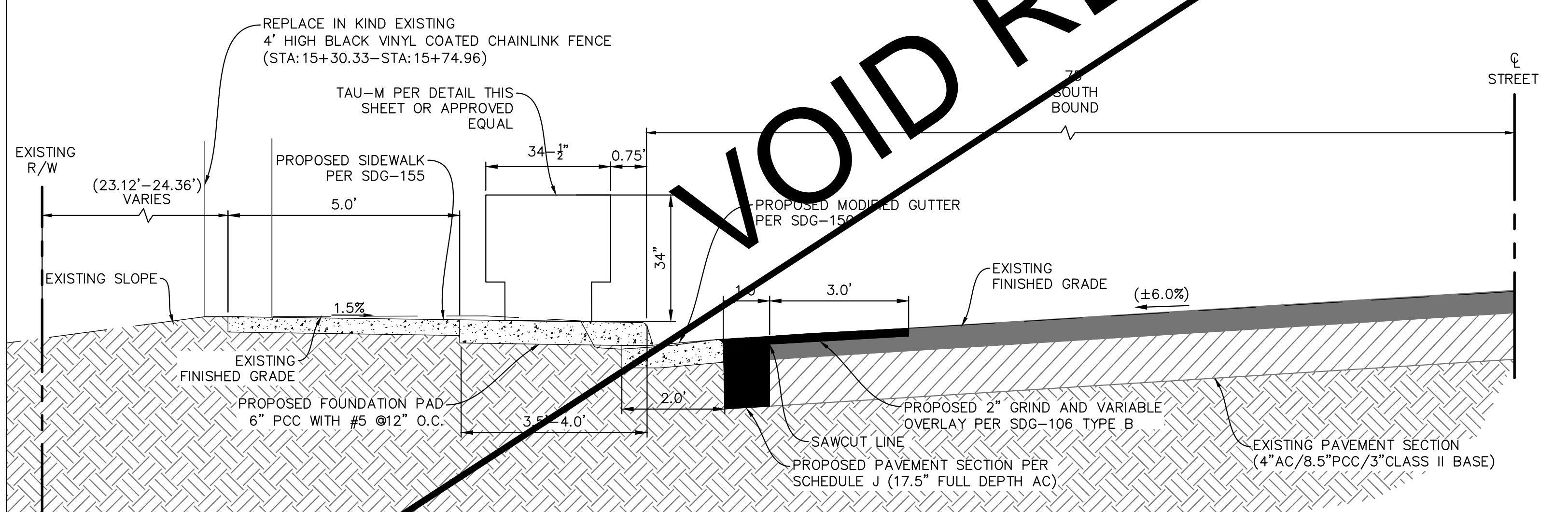

**TORREY PINES ROAD  
TAU-M DETAIL  
SECTION D-D**  
(STA: 15+52.10-15+67.41)  
NOT TO SCALE

- NOTES: UNLESS OTHERWISE SPECIFIED:
1. TAU-M SYSTEM SHALL BE INSTALLED PER MANUFACTURER'S INSTRUCTIONS.
  2. SEE ASSEMBLY AND INSTALLATION MANUAL FOR ADDITIONAL DETAILS.
  3. FOUNDATION MATERIAL SPECIFICATIONS, AND ANCHORAGE MUST BE IN ACCORDANCE WITH LTS FOUNDATION SPECIFICATIONS FOR CONCRETE FOUNDATIONS REFERENCE LTS DRAWING A04013.
  4. PEDESTRIAN SIDE INSTALL TERMINAL CONNECTOR ANCHORED TO CONCRETE BARRIER. END PANEL MUST OVERLAP TERMINAL CONNECTOR.
- CONSTRUCTION OF A BLOCK END THAT TRANSITIONS TO THE ST-75 BARRIER WILL BE NECESSARY TO ACCOMMODATE THE SYSTEM SPECIFICATIONS, CONSTRUCTION PER CALTRANS STANDARDS AND APPROVAL.

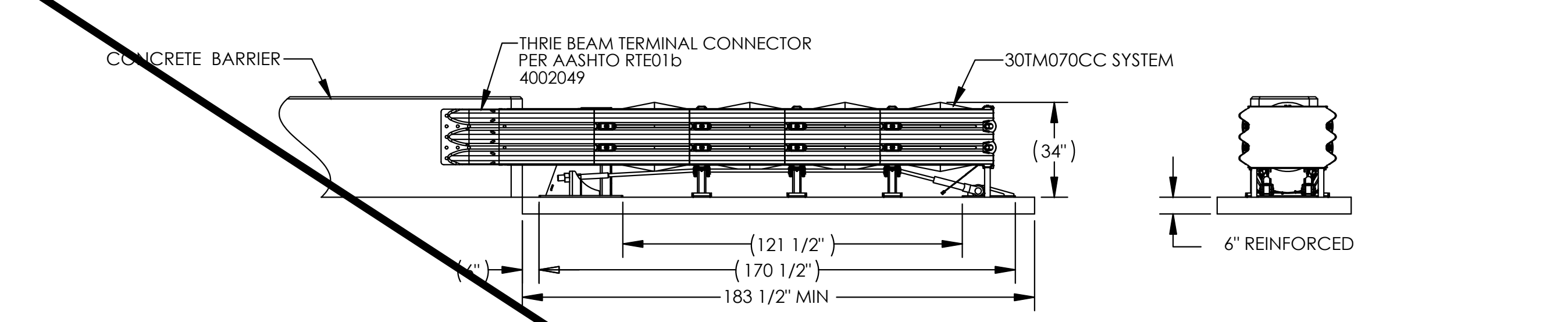
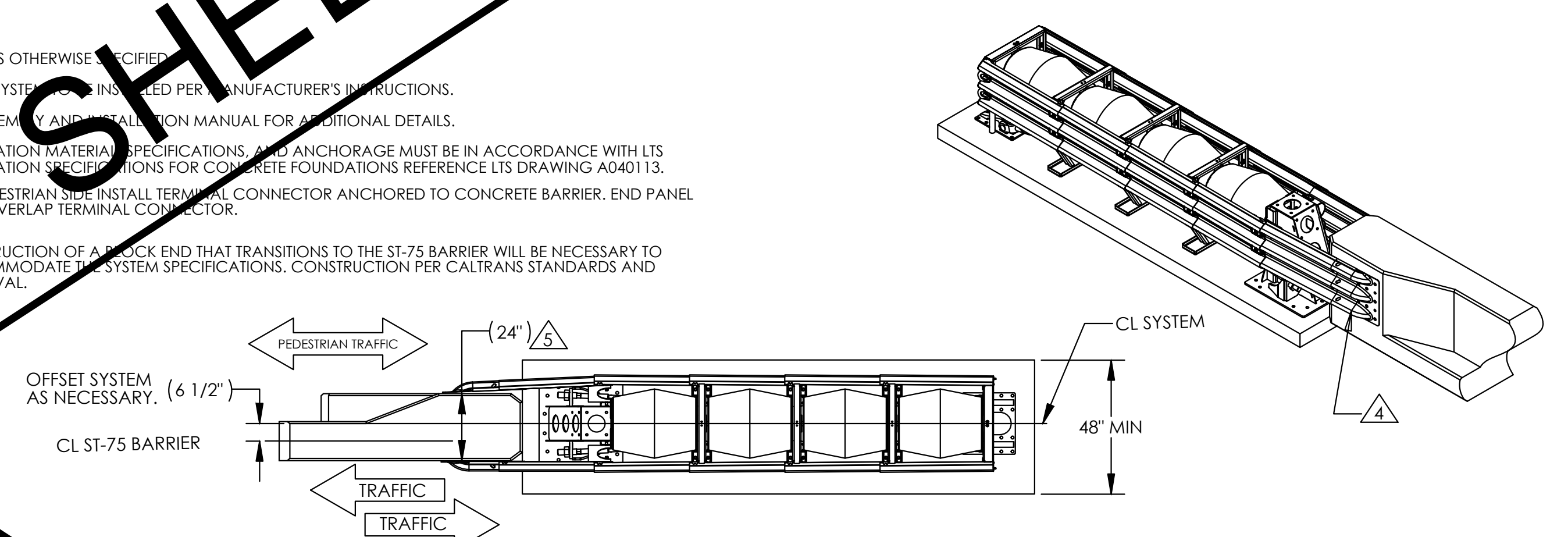

**TAU-M TO ST-75B BLOCK END (CRASH CUSHION) OR APPROVED EQUAL**  
(PART NUMBER 1835862)  
NOT TO SCALE

VOID REPLACED BY SHEET #12

DETAILS AND CROSS SECTIONS

PLANS FOR THE CONSTRUCTION OF  
TORREY PINES ROAD  
PROSPECT-COAST WALK GUARDRAIL  
STATE-AID ID: HSPSL-5004(213)  
DETAILS AND CROSS SECTIONS

CITY OF SAN DIEGO, CALIFORNIA ENGINEERING & CAPITAL PROJECTS DEPARTMENT SHEET 3 OF 10 SHEETS		WBS <u>B-19056</u>	
APPROVED BY <i>Nitsuh Aberra</i> FOR CITY ENGINEER NITSUH ABERRA PRINT DCE NAME	DATE 12/15/2025 C86236 RCE#	SUBMITTED BY NAZIE MANSURY PROJECT MANAGER	CHECKED BY RHEA VIDA PROJECT ENGINEER
DESCRIPTION	BY	APPROVED	DATE FILMED
ORIGINAL	LT/VC	<i>Nitsuh Aberra</i>	12/15/25
ADDENDUM B	NE	<i>Nitsuh Aberra</i>	03/06/26
SEE EACH SHEET CCS27 COORDINATE		SEE EACH SHEET CCS83 COORDINATE	
CONTRACTOR INSPECTOR		NTP DATE NOC DATE	
		0101250-03-D	

CONSULTANT

**Nasland** Civil Engineering  
Surveying  
Land Planning

T (858) 292-7770  
4740 Rufner Street  
San Diego, CA 92111  
nasland.com

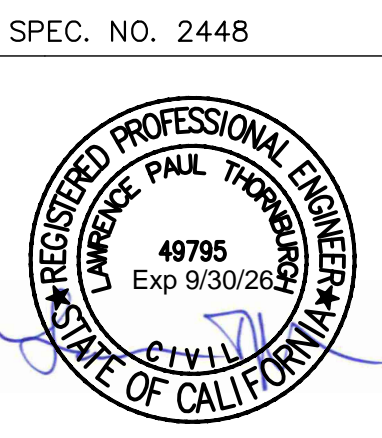

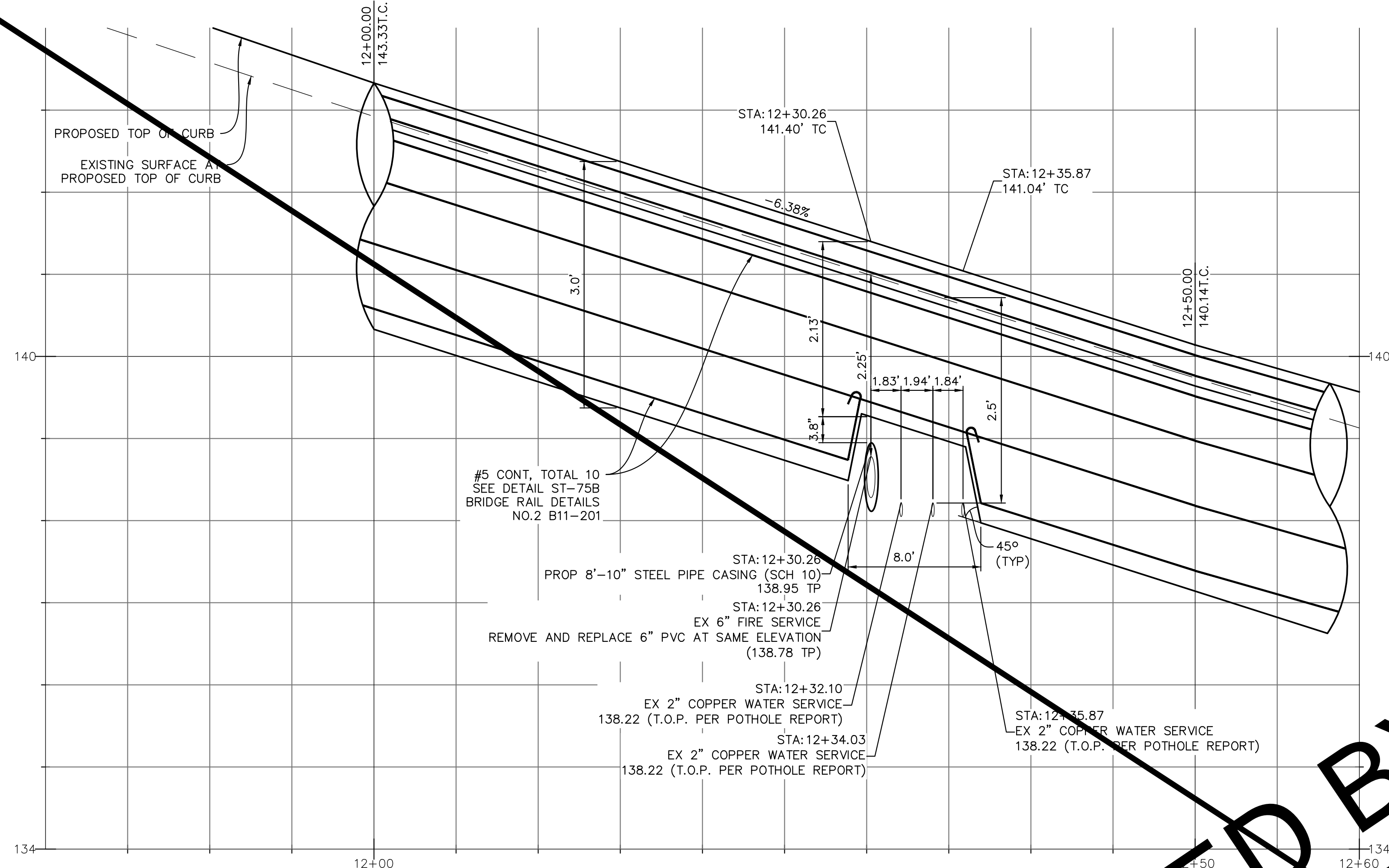

**ST-75B BRIDGE RAIL FOOTING TRANSITION**  
**PROFILE VIEW**  
 SCALE HORIZ: 1"=5'  
 VERT: 1"=1'

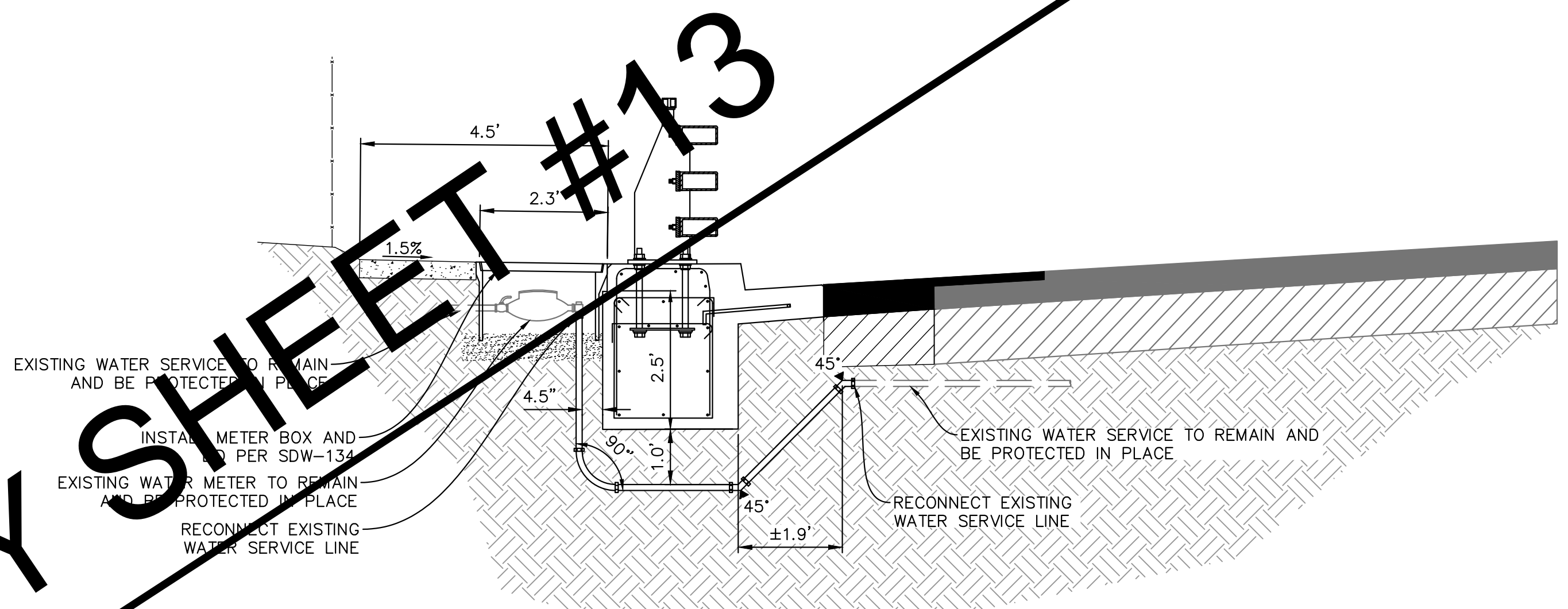

**DETAIL: WATER SERVICE RELOCATION DETAIL**

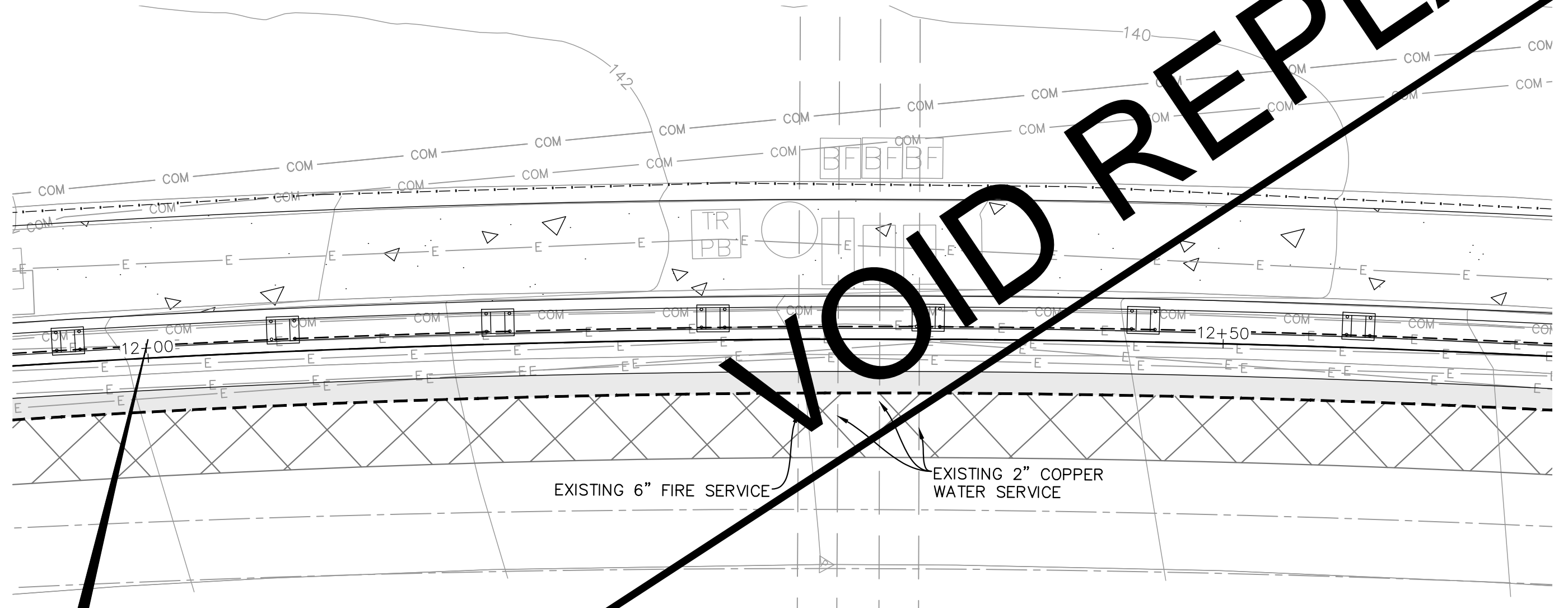

**PLAN VIEW: MODIFIED ST-75B AT EXISTING 6" FIRE**

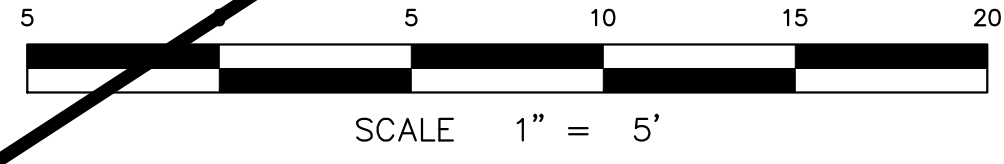

VOID REPLACED BY SHEET #13

C-2

PLANS FOR THE CONSTRUCTION OF  
 TORREY PINES ROAD  
 PROSPECT-COAST WALK GUARDRAIL  
 STATE-AID ID: HSIPSL-5004(213)  
 WATER SERVICE RELOCATION DETAILS

CITY OF SAN DIEGO, CALIFORNIA  
 ENGINEERING & CAPITAL PROJECTS DEPARTMENT  
 SHEET 4 OF 10 SHEETS

SPEC. NO. 2448		WBS <u>B-19056</u>	
APPROVED FOR CITY ENGINEER NITSUH ABERRA PRINT DCE NAME	DATE 12/15/2025 C86236 RCE#	SUBMITTED BY NAZIE MANSURY PROJECT MANAGER	CHECKED BY RHEA VIDA PROJECT ENGINEER
DESCRIPTION	BY	APPROVED	DATE FILMED
ORIGINAL	LT/VC	<i>[Signature]</i>	12/15/25
ADDENDUM B	NE	<i>[Signature]</i>	03/06/26
		SEE EACH SHEET CCS27 COORDINATE	SEE EACH SHEET CCS83 COORDINATE

CONSULTANT



**Nasland** Civil Engineering  
 Surveying  
 Land Planning

T (858) 292-7770  
 4740 Ruffner Street  
 San Diego, CA 92111  
 nasland.com



CONTRACTOR INSPECTOR \_\_\_\_\_

NTP DATE \_\_\_\_\_  
 NOC DATE \_\_\_\_\_

0101250-04-D

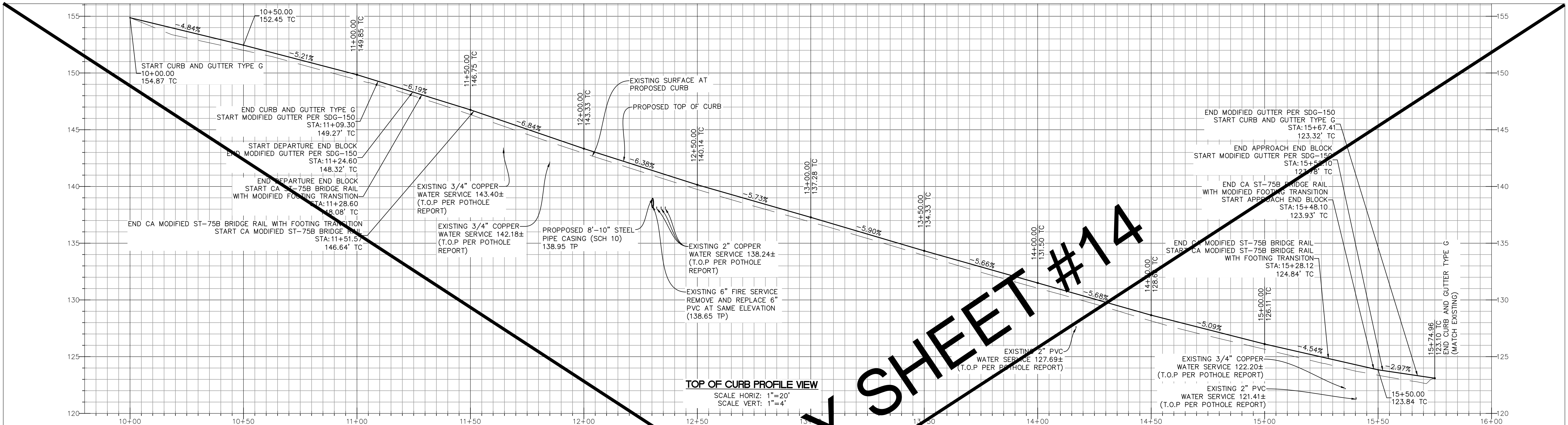

**CONSTRUCTION NOTES**

1. INSTALL CONCRETE SIDEWALK PER SDG-155.
2. INSTALL 6" CONCRETE CURB AND GUTTER TYPE G PER SDG-151.
3. REMOVE EXISTING ACC/PCC SECTION. CONSTRUCT PAVEMENT SECTION PER SDG-103 SCHEDULE J. (17.5" FULL DEPTH AC).
4. 2" GRIND AND VARIABLE OVERLAY TORREY PINES ROAD PER SDG-106 TYPE B. (WIDTH=3.0').
5. FURNISH AND INSTALL CALIFORNIA MODIFIED ST-75B BRIDGE RAIL PER CALTRANS REVISED STANDARD PLAN RSP B11-201, AND DETAIL ON SHEET C-1. LENGTH PER PLAN.
6. FURNISH AND INSTALL END BLOCK PER CALTRANS REVISED STANDARD PLAN RSP B11-201 AND B11-202.
7. FURNISH AND INSTALL TAU-M TO ST-75B BLOCK END (CRASH CUSHION) PER DETAIL ON SHEET 3 OR APPROVED EQUAL.
8. INSTALL MODIFIED CONCRETE GUTTER. SEE SECTIONS A AND D FOR DETAILS.
9. INSTALL MODIFIED FOOTING TRANSITION PER SECTION B-B ON SHEET 3.
10. CONTRACTOR TO RELOCATE EXISTING WATER SERVICE PER WATER SERVICE RELOCATION DETAIL ON SHEET 4.
12. REPLACE AND ADJUST TO GRADE WATER METER BOX AND LID PER SDW-134 AND SDW-136.

13. ADJUST TELEPHONE PULLBOX BOX AND LID TO GRADE. COORDINATE WITH AT&T FOR NEW BOX AND LID.
15. INSTALL PEDESTRIAN BARRICADE PER SDG-141.
16. INSTALL VINYL COATED CHAINLINK FENCE IN KIND.
17. REMOVE AND ADJUST PULLBOX BOX AND LID. MATCH EXISTING OR APPROVED EQUAL.
18. REMOVE AND ADJUST ELECTRICAL PULLBOX BOX AND LID. MATCH EXISTING OR APPROVED EQUAL. CONTRACTOR TO COORDINATE WITH SDGE.
19. INSTALL FOOTING TRANSITION OVER FIRE SERVICE AND WATER SERVICES. SEE DETAIL ON SHEET 4.

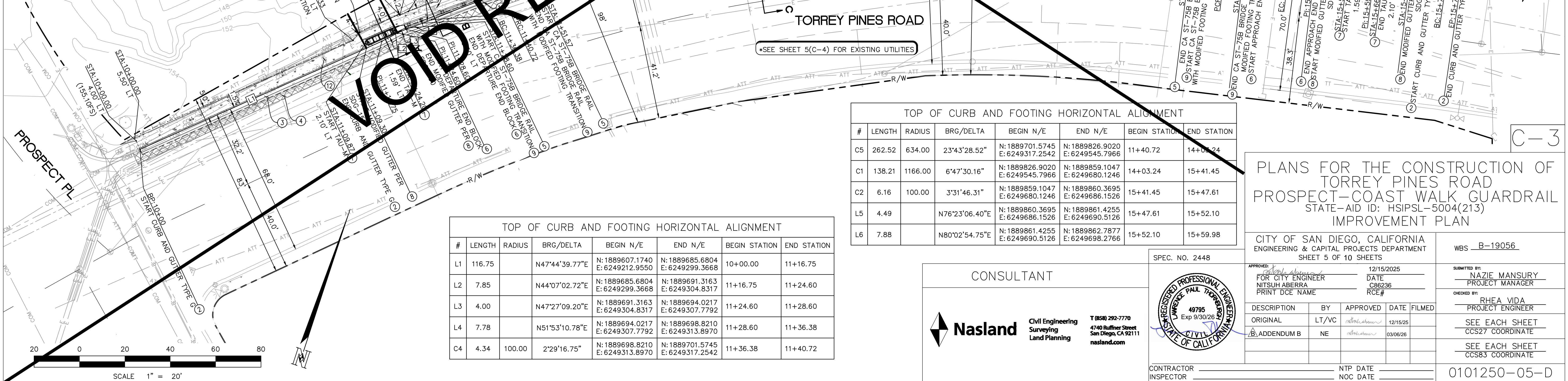

**TOP OF CURB AND FOOTING HORIZONTAL ALIGNMENT**

#	LENGTH	RADIUS	BRG/DELTA	BEGIN N/E	END N/E	BEGIN STATION	END STATION
L1	116.75		N47°44'39.77"E	N: 1889607.1740 E: 6249212.9550	N: 1889685.6804 E: 6249299.3668	10+00.00	11+16.75
L2	7.85		N44°07'02.72"E	N: 1889685.6804 E: 6249299.3668	N: 1889691.3163 E: 6249304.8317	11+16.75	11+24.60
L3	4.00		N47°27'09.20"E	N: 1889691.3163 E: 6249304.8317	N: 1889694.0217 E: 6249307.7792	11+24.60	11+28.60
L4	7.78		N51°53'10.78"E	N: 1889694.0217 E: 6249307.7792	N: 1889698.8210 E: 6249313.8970	11+28.60	11+36.38
C4	4.34	100.00	2°29'16.75"	N: 1889698.8210 E: 6249313.8970	N: 1889701.5745 E: 6249317.2542	11+36.38	11+40.72

**TOP OF CURB AND FOOTING HORIZONTAL ALIGNMENT**

#	LENGTH	RADIUS	BRG/DELTA	BEGIN N/E	END N/E	BEGIN STATION	END STATION
C5	262.52	634.00	23°43'28.52"	N: 1889701.5745 E: 6249317.2542	N: 1889826.9020 E: 6249545.7966	11+40.72	14+00.24
C1	138.21	1166.00	6°47'30.16"	N: 1889826.9020 E: 6249545.7966	N: 1889859.1047 E: 6249680.1246	14+03.24	15+41.45
C2	6.16	100.00	3°31'46.31"	N: 1889859.1047 E: 6249680.1246	N: 1889860.3695 E: 6249686.1526	15+41.45	15+47.61
L5	4.49		N76°23'06.40"E	N: 1889860.3695 E: 6249686.1526	N: 1889861.4255 E: 6249690.5126	15+47.61	15+52.10
L6	7.88		N80°02'54.75"E	N: 1889861.4255 E: 6249690.5126	N: 1889862.7877 E: 6249698.2766	15+52.10	15+59.98

**CONSULTANT**

**Nasland** Civil Engineering  
Surveying  
Land Planning

T (858) 292-7770  
4740 Rufner Street  
San Diego, CA 92111  
nasland.com

SPEC. NO. 2448

**PLANS FOR THE CONSTRUCTION OF  
TORREY PINES ROAD  
PROSPECT-COAST WALK GUARDRAIL  
STATE-AID ID: HSPSL-5004(213)  
IMPROVEMENT PLAN**

CITY OF SAN DIEGO, CALIFORNIA  
ENGINEERING & CAPITAL PROJECTS DEPARTMENT  
SHEET 5 OF 10 SHEETS

wbs B-19056

APPROVED FOR CITY ENGINEER NITSU ABERRA PRINT DCE NAME	DATE 12/15/2025 C86236 RCE#	SUBMITTED BY <u>NAZIE MANSURY</u> PROJECT MANAGER
DESCRIPTION ORIGINAL ADDENDUM B	BY LT/VC NE	APPROVED DATE FILMED 12/15/25 03/06/26

CHECKED BY  
RHEA VIDA  
PROJECT ENGINEER

SEE EACH SHEET  
CCS27 COORDINATE

SEE EACH SHEET  
CCS83 COORDINATE

CONTRACTOR INSPECTOR \_\_\_\_\_ NTP DATE \_\_\_\_\_  
INSPECTOR \_\_\_\_\_ NOC DATE \_\_\_\_\_

0101250-05-D

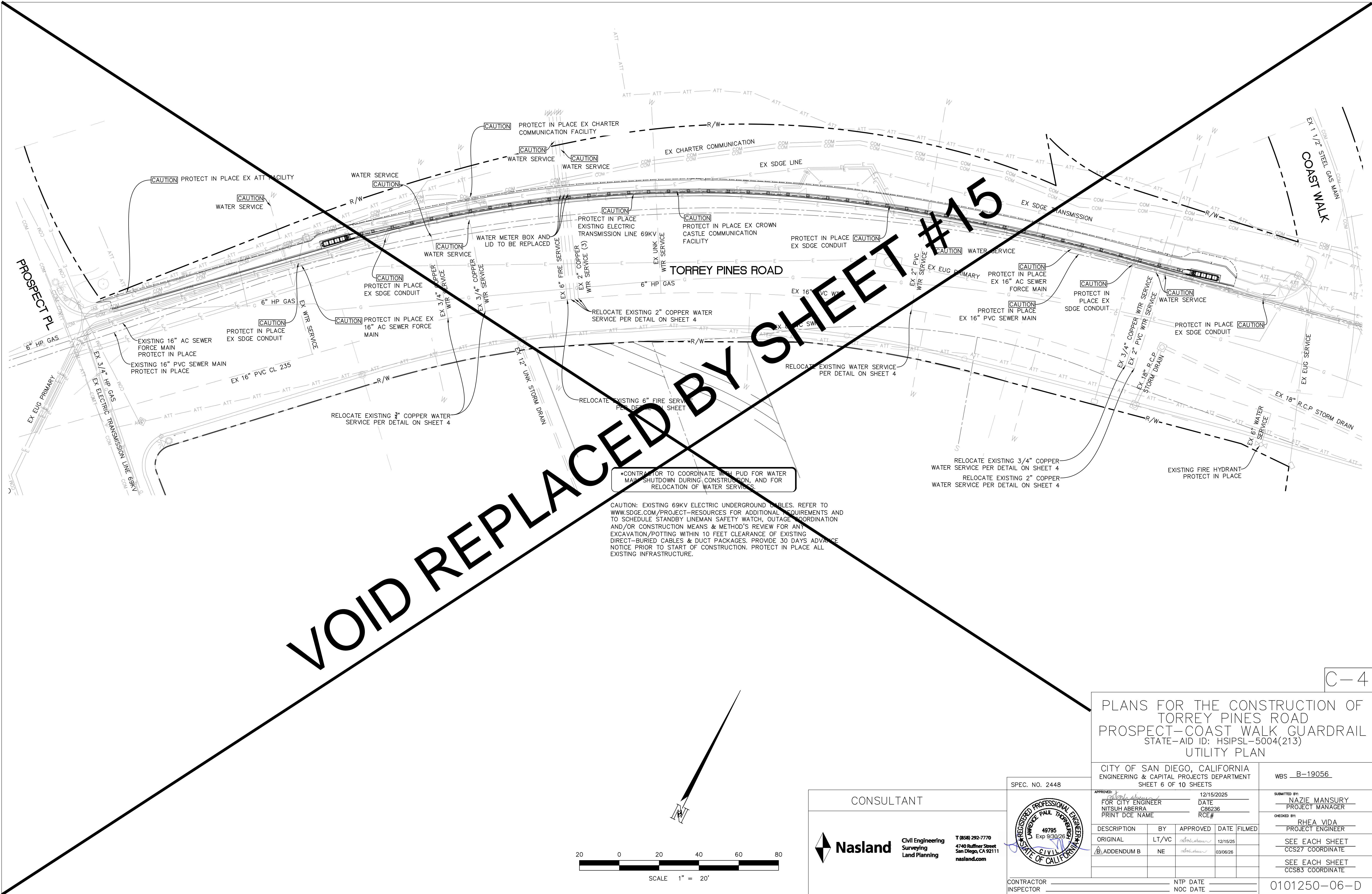

VOID REPLACED BY SHEET #15

\*CONTRACTOR TO COORDINATE WITH PUD FOR WATER MAIN SHUTDOWN DURING CONSTRUCTION, AND FOR RELOCATION OF WATER SERVICES

CAUTION: EXISTING 69KV ELECTRIC UNDERGROUND CABLES. REFER TO WWW.SDGE.COM/PROJECT-RESOURCES FOR ADDITIONAL REQUIREMENTS AND TO SCHEDULE STANDBY LINEMAN SAFETY WATCH, OUTAGE COORDINATION AND/OR CONSTRUCTION MEANS & METHOD'S REVIEW FOR ANY EXCAVATION/POTTING WITHIN 10 FEET CLEARANCE OF EXISTING DIRECT-BURIED CABLES & DUCT PACKAGES. PROVIDE 30 DAYS ADVANCE NOTICE PRIOR TO START OF CONSTRUCTION. PROTECT IN PLACE ALL EXISTING INFRASTRUCTURE.

UTILITY PLAN

C-4

PLANS FOR THE CONSTRUCTION OF  
TORREY PINES ROAD  
PROSPECT-COAST WALK GUARDRAIL  
STATE-AID ID: HSIPSL-5004(213)  
UTILITY PLAN

CITY OF SAN DIEGO, CALIFORNIA  
ENGINEERING & CAPITAL PROJECTS DEPARTMENT  
SHEET 6 OF 10 SHEETS

APPROVED BY: <i>[Signature]</i>		DATE: 12/15/2025		SUBMITTED BY: NAZIE MANSURY	
FOR CITY ENGINEER: NITSUH ABERRA		DATE: C86236		PROJECT MANAGER	
PRINT DCE NAME:		RCE#:		CHECKED BY: RHEA VIDA	
DESCRIPTION		BY	APPROVED	DATE	FILMED
ORIGINAL	LT/VC	<i>[Signature]</i>		12/15/25	
ADDENDUM B	NE	<i>[Signature]</i>		03/06/26	
					SEE EACH SHEET CCS27 COORDINATE
					SEE EACH SHEET CCS83 COORDINATE

CONTRACTOR INSPECTOR: \_\_\_\_\_ NTP DATE: \_\_\_\_\_ NOC DATE: \_\_\_\_\_

0101250-06-D

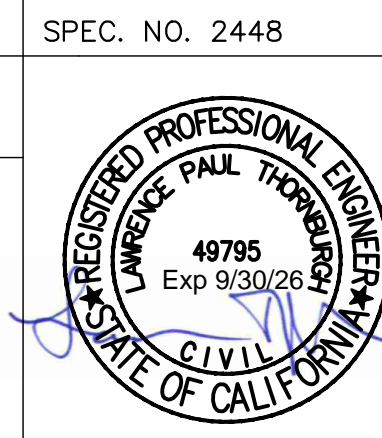

CONSULTANT

**Nasland** Civil Engineering  
Surveying  
Land Planning

T (858) 292-7770  
4740 Ruffner Street  
San Diego, CA 92111  
nasland.com

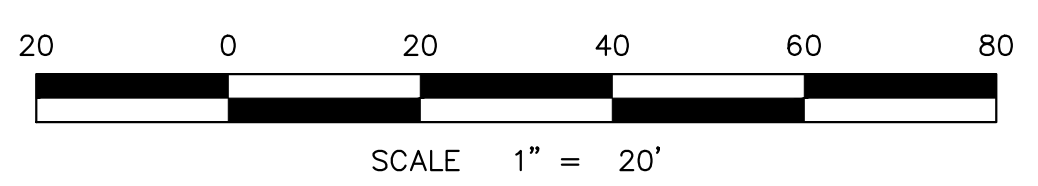

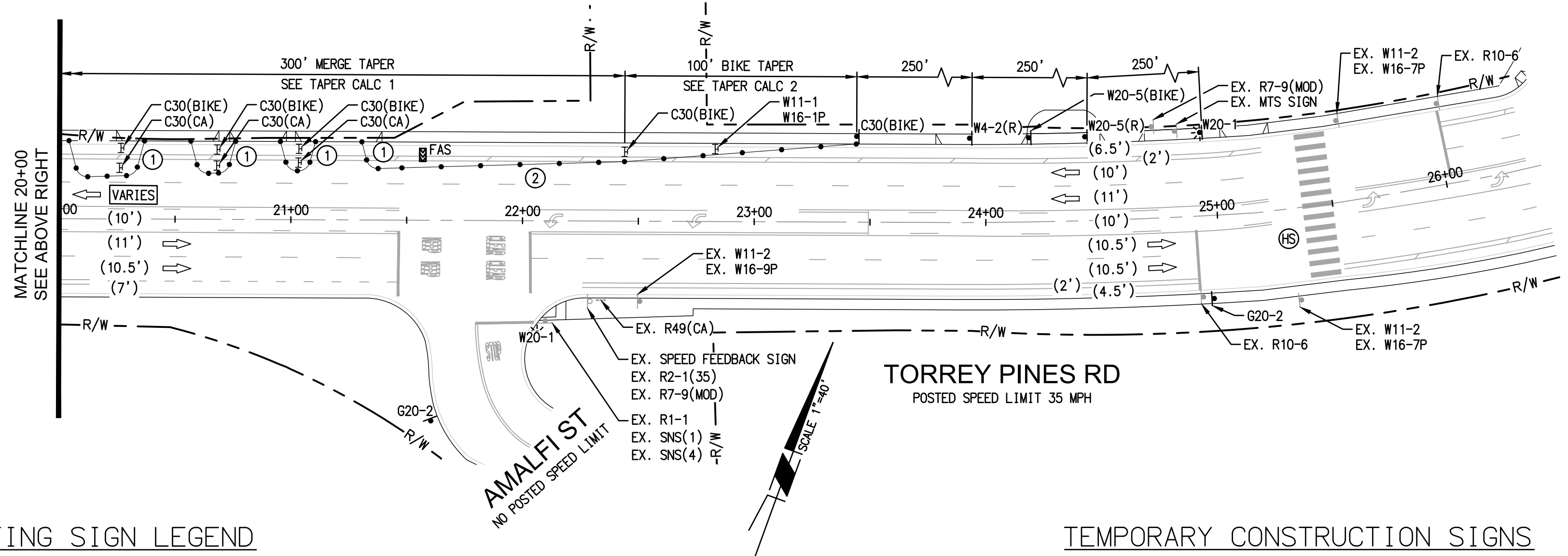
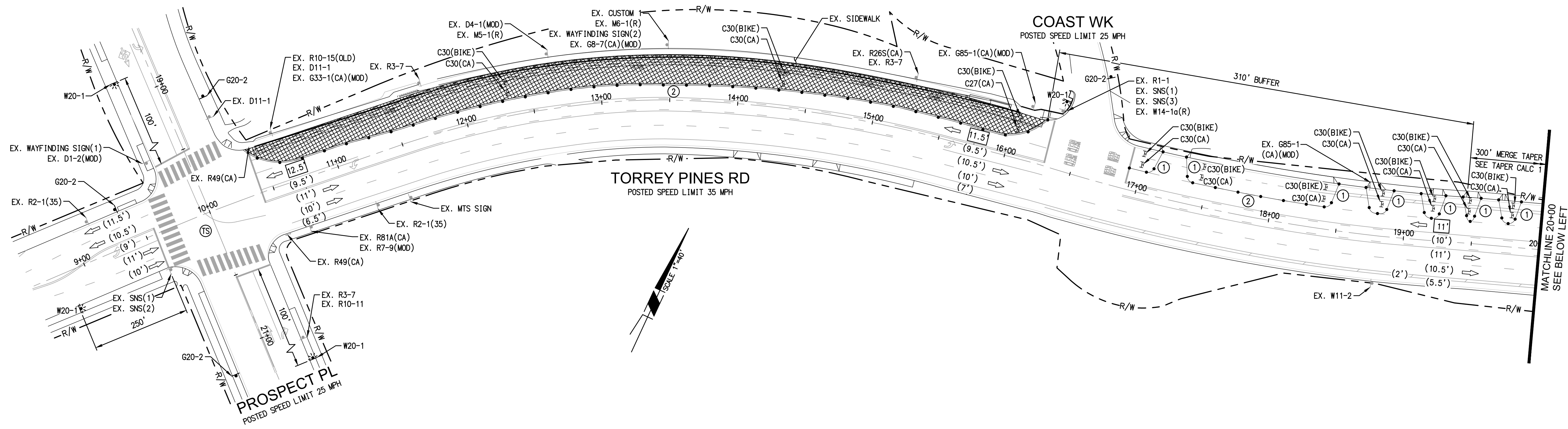

**TAPER LENGTH CALCULATIONS**

1. MIN. MERGE TAPER =  $L = [(10.5') \times (35^2) / 60] = 215' \rightarrow 300'$   
 2. MIN. BIKE TAPER =  $L / 3 = [(8') \times (25^2) / 60] / 3 = 28' \rightarrow 100'$

$L$  = LENGTH OF TRANSITION FOR SPEEDS OF 40 MPH OR LESS  
 $= W \times (S^2) / 60$

$W$  = OFFSET  
 $S$  = APPROACH SPEED

**CONSTRUCTION NOTES**

① CONES/DELINEATORS SHALL BE LOCATED AS SHOWN ON PLAN.  
 ② CONES/DELINEATORS SHALL BE SPACED AT 17' INTERVALS.

- TRAFFIC CONTROL LEGEND**
- ▲ EXISTING SIGN ON POST
  - ◀ EXISTING SIGN ON POLE
  - ⊥ EXISTING TYPE II PEDESTRIAN BARRICADE
  - EXISTING SIDEWALK
  - ▲ TEMPORARY CONSTRUCTION SIGN
  - ⚡ TEMPORARY CONSTRUCTION SIGN WITH FLASHING BEACON
  - PORTABLE CONES OR DELINEATORS
  - DIRECTION OF TRAFFIC
  - ⚡ FLASHING ARROW SIGN (FAS)
  - ⊥ TYPE II BARRICADE WITH CONSTRUCTION SIGN
  - ▭ WATER FILLED BARRIER
  - Ⓢ EXISTING TRAFFIC SIGNAL
  - Ⓜ EXISTING HAWK SIGNAL
  - (XX') EXISTING LANE WIDTH
  - ⊠ MINIMUM PROPOSED CONSTRUCTION LANE WIDTH

**EXISTING SIGN LEGEND**

CUSTOM 1	D1-2(MOD)	D4-1(MOD)	D11-1	G8-7(CA)(MOD)	G33-1(CA)(MOD)	G85-1(CA)(MOD)	M5-1(R)
M6-1(R)	MTS SIGN	R1-1	R2-1(35)	R3-7	R7-9(MOD)	R10-6	R10-11
R10-15(OLD)	R26S(CA)	R49(CA)	R81A(CA)	SNS(1)	SNS(2)	SNS(3)	SNS(4)
SPEED FEEDBACK SIGN	W11-2	W14-1a(R)	W16-7P	W16-9P	WAYFINDING SIGN(1)	WAYFINDING SIGN(2)	MUSEUM OF CONTEMPORARY ART SAN DIEGO

**TEMPORARY CONSTRUCTION SIGNS**

C27(CA)	C30(BIKE)	C30(CA)	G20-2
W4-2(R)	W11-1	W16-1P	W20-1
W20-5(BIKE)	W20-5(R)		

**HOURS OF WORK**

7:00PM - 3:00AM  
 MONDAY THROUGH FRIDAY

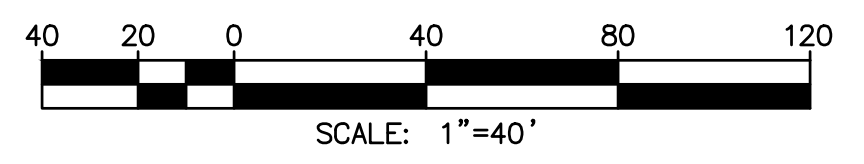

TC-1

**PLANS FOR THE CONSTRUCTION OF TORREY PINES ROAD PROSPECT-COAST WALK GUARDRAIL STATE-AID ID: HSIPSL-5004(213) TRAFFIC CONTROL PLAN WORKING HOURS**

CITY OF SAN DIEGO, CALIFORNIA  
 ENGINEERING & CAPITAL PROJECTS DEPARTMENT  
 SHEET T1 OF T3 SHEETS

APPROVED:  FOR CITY ENGINEER NITSUH ABERRA PRINT DCE NAME		DATE: 12/15/2025 C86236 RCE#	WBS: B-19056
SUBMITTED BY: NAZIE MANSURY PROJECT MANAGER		CHECKED BY: RHEA VIDA PROJECT ENGINEER	
DESCRIPTION	BY	APPROVED	DATE
ORIGINAL	RB/GP		12/15/25
ADDENDUM B	NE		03/06/26
246-1683 CCS27 COORDINATE		6244407-1886444 CCS83 COORDINATE	

12/8/2025

CONTRACTOR \_\_\_\_\_  
 INSPECTOR \_\_\_\_\_

NTP DATE \_\_\_\_\_  
 NOC DATE \_\_\_\_\_

STC TRAFFIC, INC.  
 5973 AVENIDA ENCINAS, #218  
 CARLSBAD, CA 92008  
 PH: 760-602-4290  
 INFO@STCTRAFFIC.COM  
 WWW.STCTRAFFIC.COM

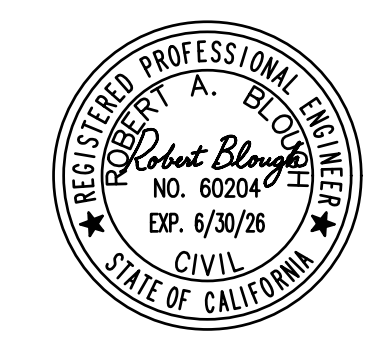



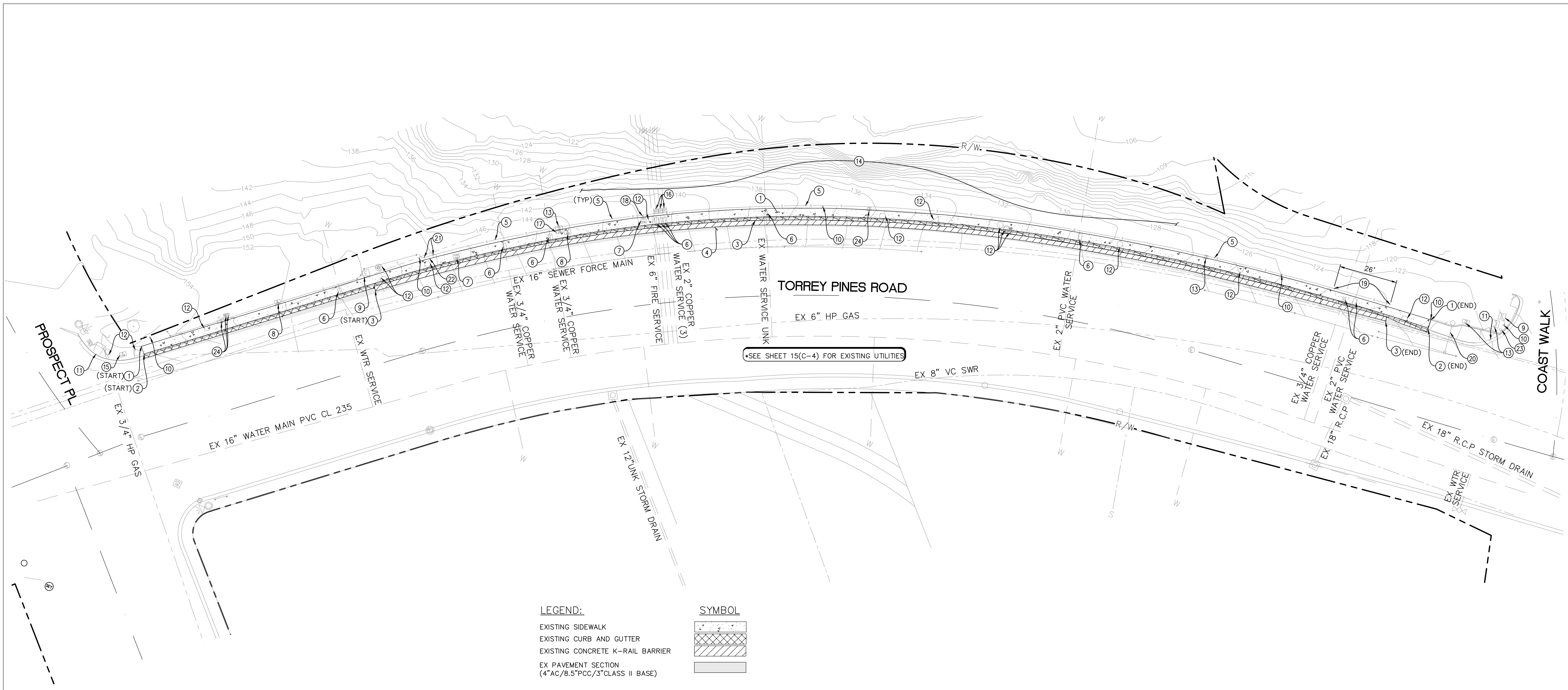

**LEGEND:**

SYMBOL	DESCRIPTION
	EXISTING SIDEWALK
	EXISTING CURB AND GUTTER
	EXISTING CONCRETE K-RAIL BARRIER
	EX PAVEMENT SECTION (4\"/>

**NOTE:**

- CONTRACTOR TO POTHOLE AND VERIFY LOCATION AND DEPTH OF ALL FACILITIES PRIOR TO EXCAVATION.
- SEE TRAFFIC PLANS FOR SIGN REMOVAL AND REPLACEMENT.

**EXISTING CONDITIONS AND DEMOLITION NOTES**

- REMOVE EXISTING SIDEWALK.
- REMOVE EXISTING CURB AND GUTTER.
- REMOVE EXISTING TEMPORARY CONCRETE K-RAIL BARRIER.
- REMOVE EXISTING AC/PCC. WIDTH VARIES.
- EXISTING CHAIN LINK FENCE TO REMAIN AND BE PROTECTED IN PLACE.
- EXISTING WATER METER BOX TO BE REMOVED AND REPLACED.
- EXISTING TRAFFIC SIGNAL PULLBOX TO BE REMOVED AND REPLACED.
- EXISTING ELECTRICAL PULLBOX TO BE ADJUSTED TO GRADE BY SDGE.
- EXISTING ELECTRICAL PEDESTAL TO REMAIN AND BE PROTECTED IN PLACE.
- EXISTING SIGN. REFER TO SHEET T-2 FOR ALL SIGNAGE REMOVAL OR RELOCATIONS.
- EXISTING CURB RAMP TO REMAIN AND BE PROTECTED IN PLACE.
- EXISTING SURVEY MONUMENT TO REMAIN AND BE PROTECTED IN PLACE.
- EXISTING COMMUNICATION VAULT TO REMAIN AND BE PROTECTED IN PLACE.
- EXISTING LANDSCAPING AND IRRIGATION TO REMAIN AND BE PROTECTED IN PLACE.
- EXISTING ELECTRICAL PULLBOX TO REMAIN AND BE PROTECTED IN PLACE.
- EXISTING BACKFLOW PREVENTER TO REMAIN AND BE PROTECTED IN PLACE.
- EXISTING AT&T PULLBOX TO BE ADJUSTED TO GRADE BY AT&T.
- REMOVE EXISTING FOUNDATION.
- REMOVE PORTION OF EXISTING 4' HIGH BLACK VINYL COATED CHAINLINK FENCE.
- EXISTING STREET LIGHT TO REMAIN AND BE PROTECTED IN PLACE.
- EXISTING GATE TO BE PROTECTED IN PLACE.
- REMOVE EXISTING WOOD PANELS TO ACCOMMODATE NEW SIDEWALK.
- EXISTING BOLLARD TO REMAIN AND BE PROTECTED IN PLACE.
- EXISTING COMMUNICATION PEDESTAL TO REMAIN AND BE PROTECTED IN PLACE.

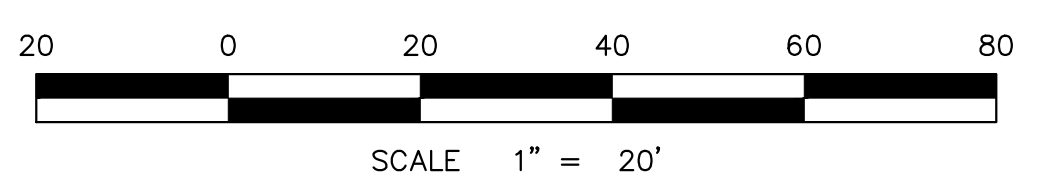

D-1

**PLANS FOR THE CONSTRUCTION OF  
TORREY PINES ROAD  
PROSPECT-COAST WALK GUARDRAIL  
STATE-AID ID: HSIPSL-5004(213)  
EXISTING CONDITIONS AND DEMOLITION PLAN**

CITY OF SAN DIEGO, CALIFORNIA ENGINEERING & CAPITAL PROJECTS DEPARTMENT SHEET 11 OF 15 SHEETS		WBS <u>B-19056</u>	
APPROVED: FOR CITY ENGINEER NITSUH ABERRA PRINT DCE NAME	DATE 03/06/2026 C86236 RCE#	SUBMITTED BY: NAZIE MANSURY PROJECT MANAGER	
DESCRIPTION		BY	APPROVED
ORIGINAL	LT/VC	<i>[Signature]</i>	03/06/26
ADDENDUM B	LT/VC	<i>[Signature]</i>	03/06/26
CONTRACTOR INSPECTOR		NTP DATE NOC DATE	
		0101250-11-D	

CONSULTANT



**Nasland** Civil Engineering  
Surveying  
Land Planning

T (858) 292-7770  
4740 Ruffner Street  
San Diego, CA 92111  
nasland.com

SPEC. NO. 2448

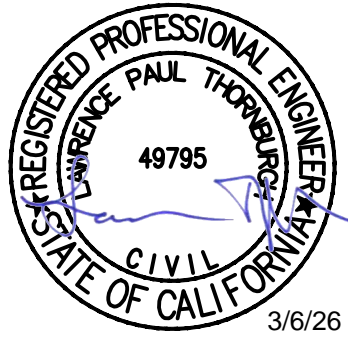

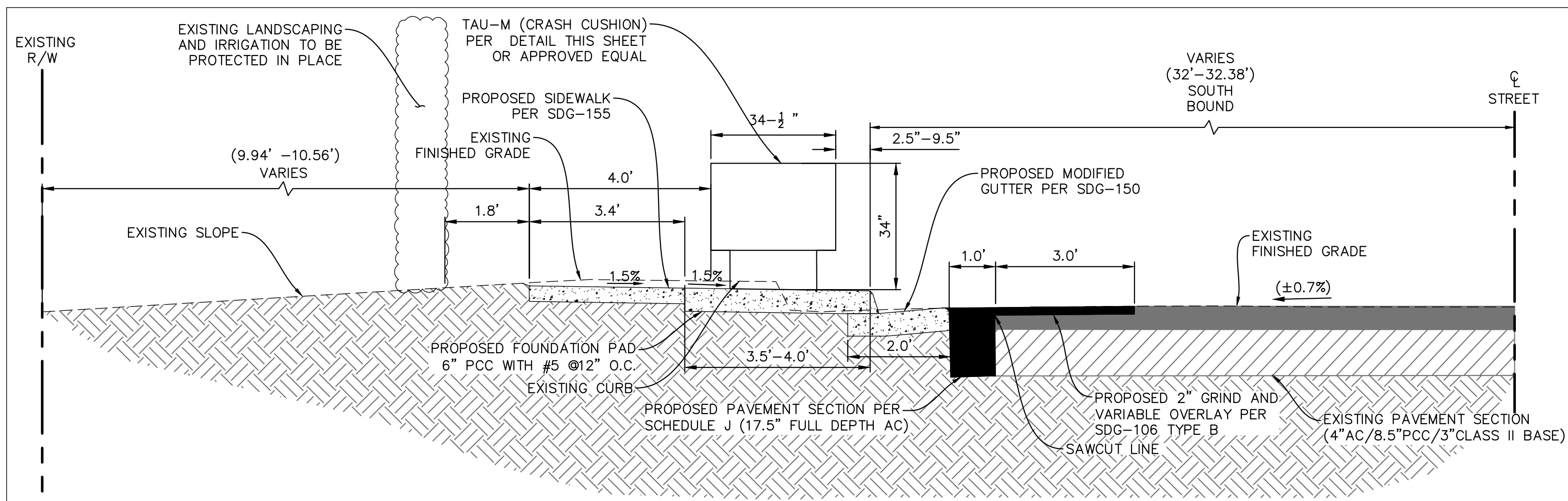

**TORREY PINES ROAD  
TAU-M DETAIL  
SECTION A-A**  
(STA: 11+09.30-11+24.60)  
NOT TO SCALE

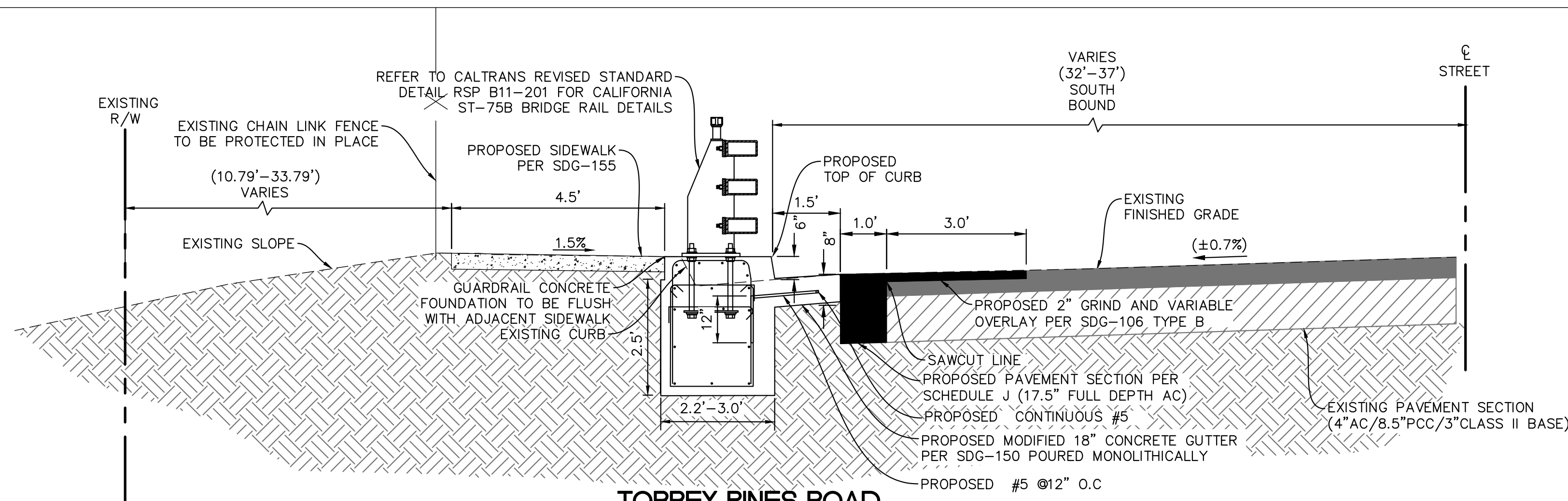

**TORREY PINES ROAD  
MODIFIED ST-75B BRIDGE RAIL FOOTING TRANSITION  
SECTION B-B**  
(STATIONS 11+28.60-11+64.63 AND 15+28.12-15+48.10)  
NOT TO SCALE

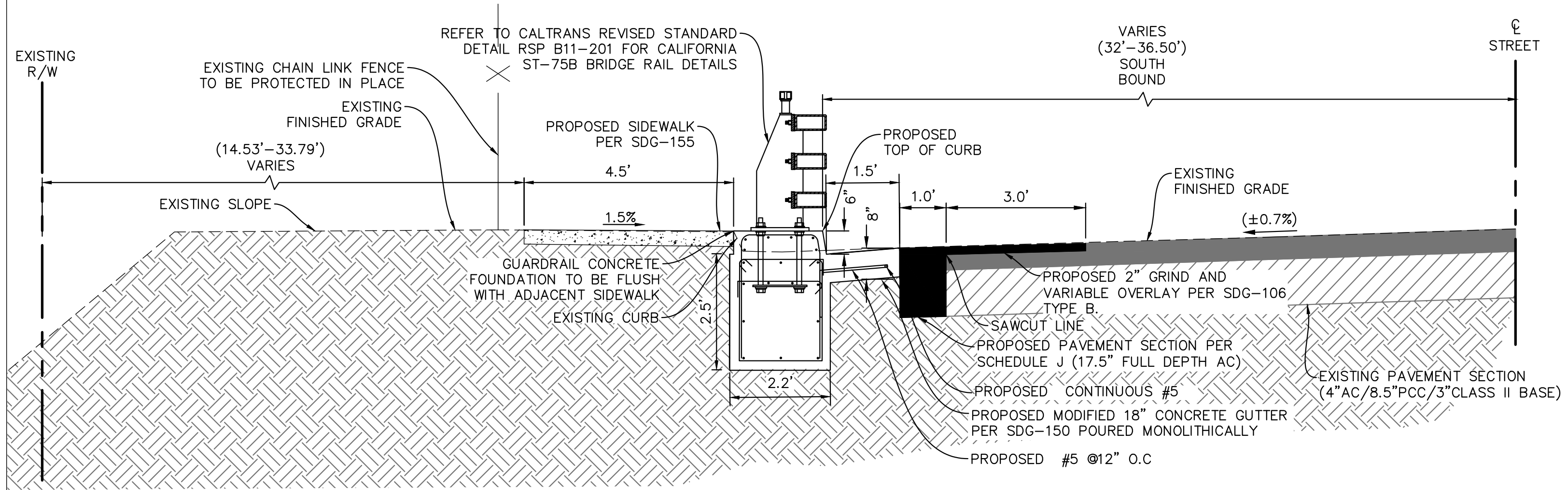

**TORREY PINES ROAD  
MODIFIED ST-75B BRIDGE RAIL WITH GUTTER DETAIL  
SECTION C-C**  
(STA: 11+64.63-15+28.12)  
NOT TO SCALE

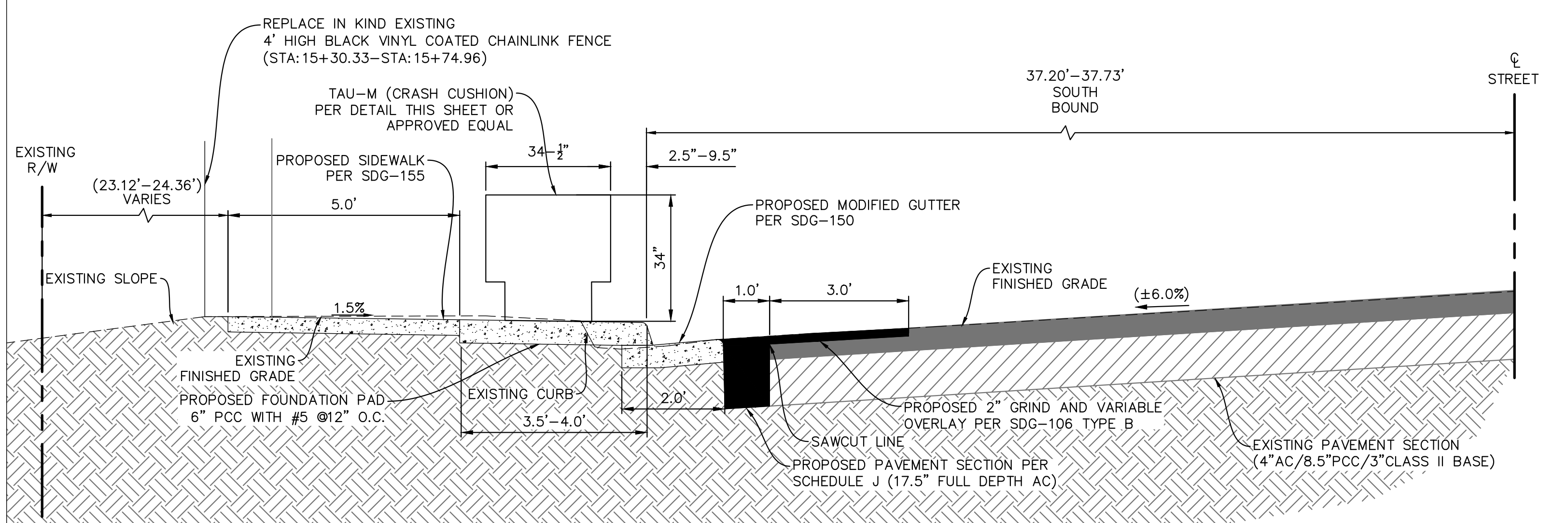

**TORREY PINES ROAD  
TAU-M DETAIL  
SECTION D-D**  
(STA: 15+52.10-15+67.41)  
NOT TO SCALE

- NOTES: UNLESS OTHERWISE SPECIFIED.
1. TAU-M SYSTEM TO BE INSTALLED PER MANUFACTURER'S INSTRUCTIONS.
  2. SEE ASSEMBLY AND INSTALLATION MANUAL FOR ADDITIONAL DETAILS.
  3. FOUNDATION MATERIAL SPECIFICATIONS AND ANCHORAGE MUST BE IN ACCORDANCE WITH ITS FOUNDATION SPECIFICATIONS FOR CONCRETE FOUNDATIONS REFERENCE ITS DRAWING A40113.
- ▲ ON PEDESTRIAN SIDE INSTALL TERMINAL CONNECTOR ANCHORED TO CONCRETE BARRIER. END PANEL MUST OVERLAP TERMINAL CONNECTOR.
- ▲ CONSTRUCTION OF A BLOCK END THAT TRANSITIONS TO THE ST-75 BARRIER WILL BE NECESSARY TO ACCOMMODATE THE SYSTEM SPECIFICATIONS. CONSTRUCTION PER CALTRANS STANDARDS AND APPROVAL.

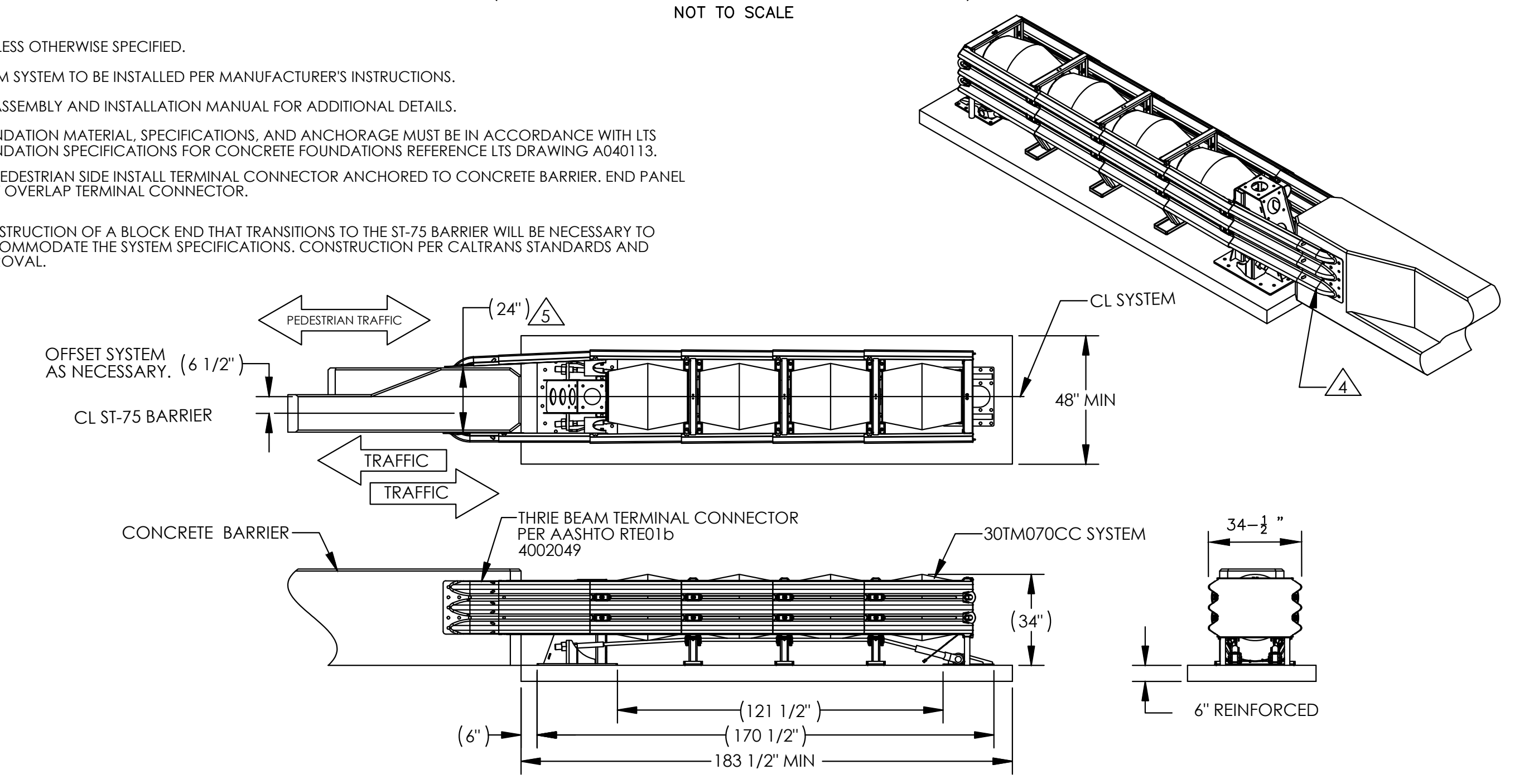

**TAU-M TO ST-75B BLOCK END (CRASH CUSHION) OR APPROVED EQUAL**  
(PART NUMBER 1835862)  
NOT TO SCALE

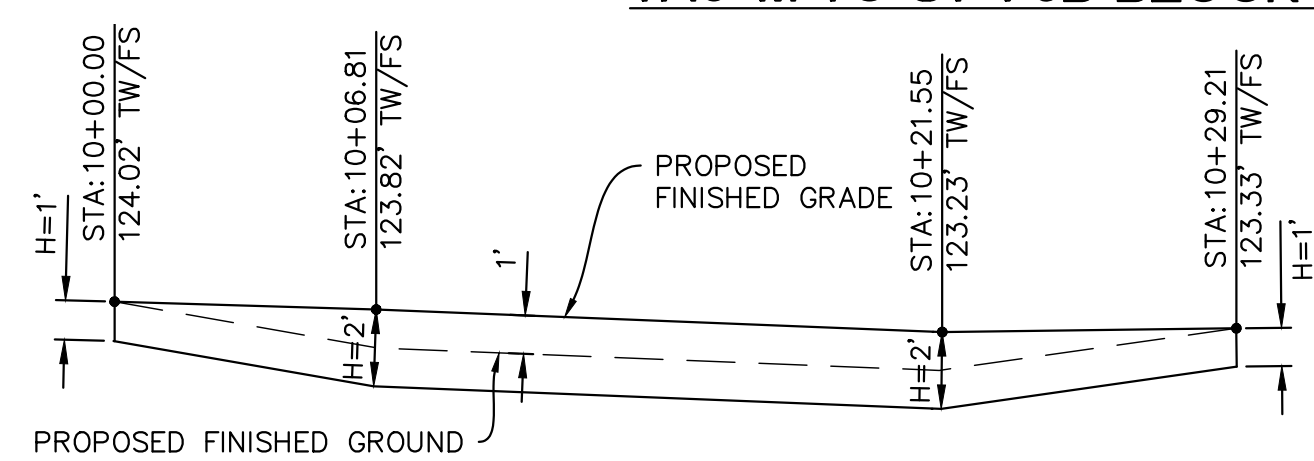

**GRAVITY RETAINING WALL DETAIL**  
NOT TO SCALE

PLANS FOR THE CONSTRUCTION OF  
TORREY PINES ROAD  
PROSPECT-COAST WALK GUARDRAIL  
STATE-AID ID: HSPSL-5004(213)  
DETAILS AND CROSS SECTIONS

CITY OF SAN DIEGO, CALIFORNIA ENGINEERING & CAPITAL PROJECTS DEPARTMENT SHEET 12 OF 15 SHEETS				WBS <u>B-19056</u>	
APPROVED: <i>[Signature]</i> FOR CITY ENGINEER NITSUH ABERRA PRINT DCE NAME		DATE 03/06/2026 C86236 RCE#		SUBMITTED BY: NAZIE MANSURY PROJECT MANAGER	
CHECKED BY: RHEA VIDA PROJECT ENGINEER		DESCRIPTION		SEE EACH SHEET CCS27 COORDINATE	
ORIGINAL		BY	APPROVED	DATE	FILMED
ADDENDUM B		LT/VC	<i>[Signature]</i>	03/06/26	
		LT/VC	<i>[Signature]</i>	03/06/26	
CONTRACTOR		NTP DATE		0101250-12-D	
INSPECTOR		NOC DATE			

CONSULTANT

**Nasland** Civil Engineering  
Surveying  
Land Planning

T (858) 292-7770  
4740 Ruffner Street  
San Diego, CA 92111  
nasland.com

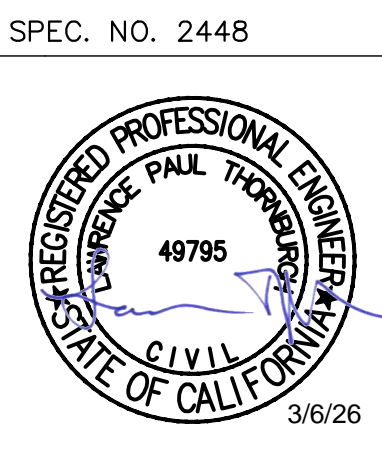

DETAILS AND CROSS SECTIONS

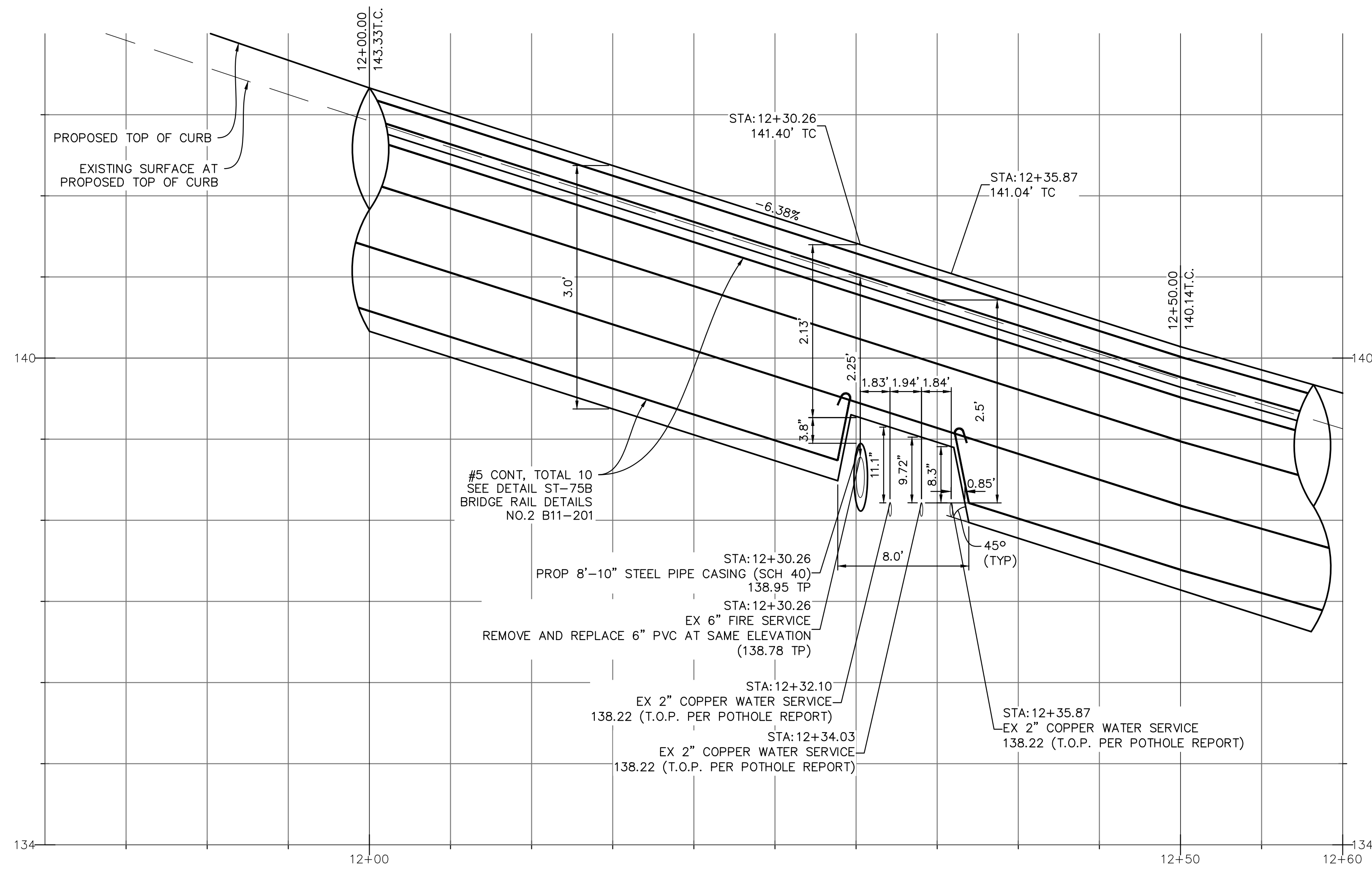

**ST-75B BRIDGE RAIL FOOTING TRANSITION**  
**PROFILE VIEW**  
 SCALE HORIZ: 1"=5'  
 VERT: 1"=1'

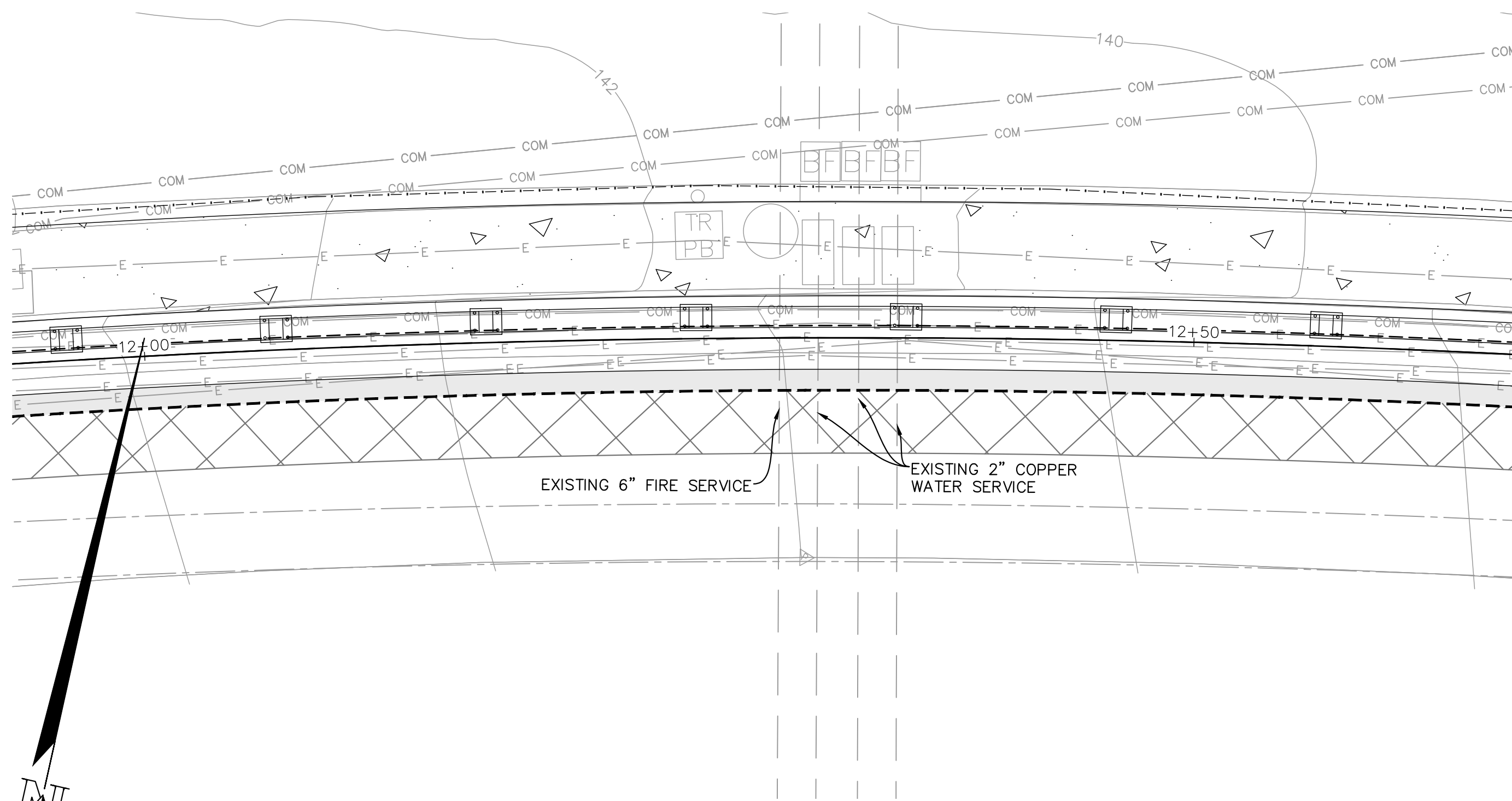

**PLAN VIEW: MODIFIED ST-75B AT EXISTING 6" FIRE**

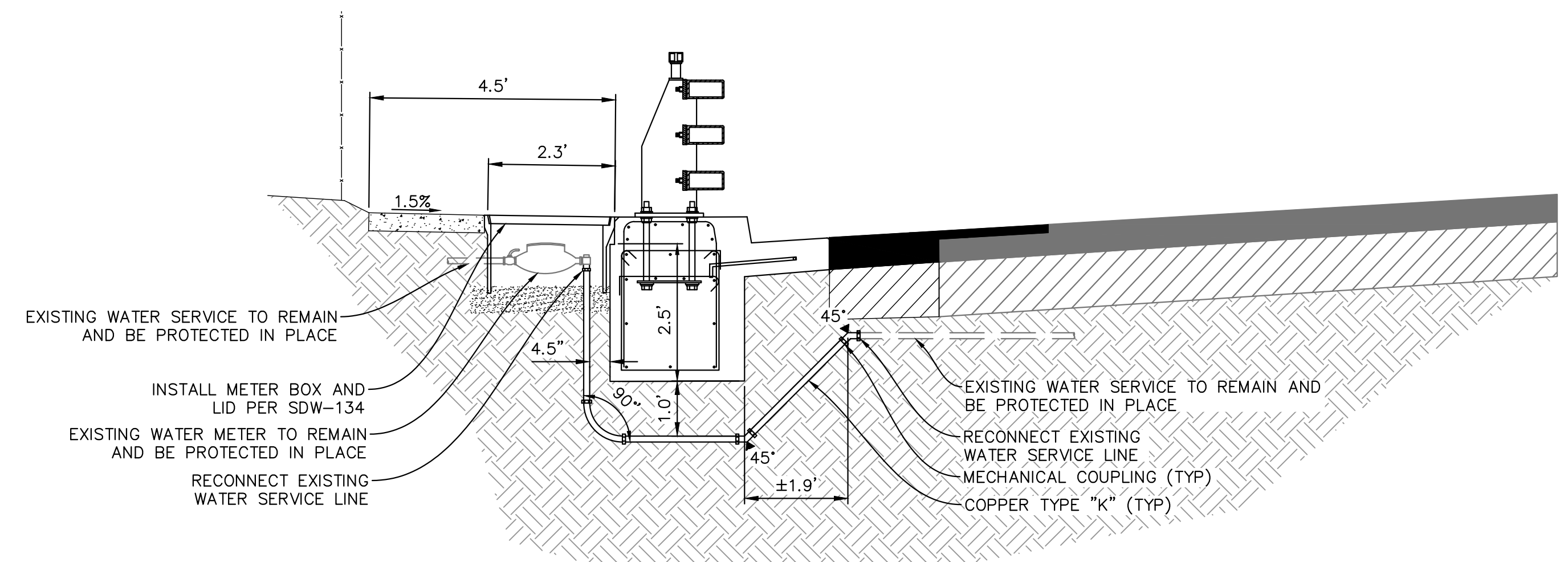
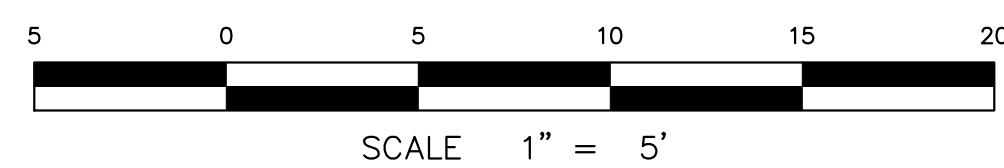

**DETAIL: WATER SERVICE RELOCATION DETAIL**

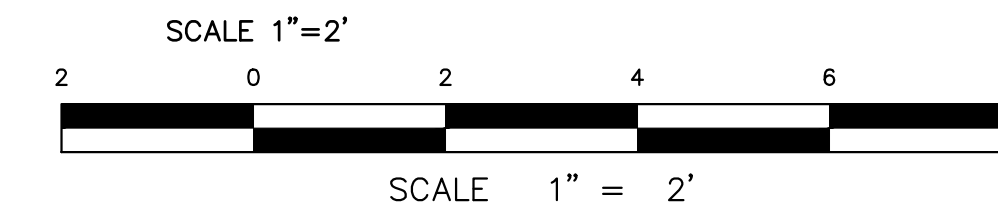

C-2

PLANS FOR THE CONSTRUCTION OF  
 TORREY PINES ROAD  
 PROSPECT-COAST WALK GUARDRAIL  
 STATE-AID ID: HSIPSL-5004(213)  
 WATER SERVICE RELOCATION DETAILS

CITY OF SAN DIEGO, CALIFORNIA  
 ENGINEERING & CAPITAL PROJECTS DEPARTMENT  
 SHEET 13 OF 15 SHEETS

SPEC. NO. 2448

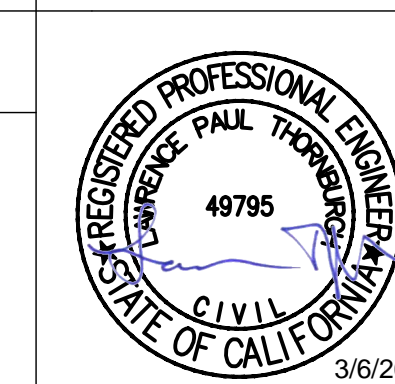

APPROVED: *[Signature]* 03/06/2026  
 FOR CITY ENGINEER DATE  
 NITSUH ABERRA C86236  
 PRINT DCE NAME RCE#

WBS B-19056

SUBMITTED BY: NAZIE MANSURY  
 PROJECT MANAGER

CHECKED BY: RHEA VIDA  
 PROJECT ENGINEER

DESCRIPTION	BY	APPROVED	DATE	FILMED
ORIGINAL	LT/VC	<i>[Signature]</i>	03/06/26	
ADDENDUM B	LT/VC	<i>[Signature]</i>	03/06/26	

SEE EACH SHEET  
 CCS27 COORDINATE

SEE EACH SHEET  
 CCS83 COORDINATE

CONTRACTOR INSPECTOR \_\_\_\_\_ NTP DATE \_\_\_\_\_  
 NOC DATE \_\_\_\_\_

0101250-13-D

CONSULTANT

**Nasland** Civil Engineering  
 Surveying  
 Land Planning

T (858) 292-7770  
 4740 Ruffner Street  
 San Diego, CA 92111  
 nasland.com

DETAILS AND CROSS SECTIONS

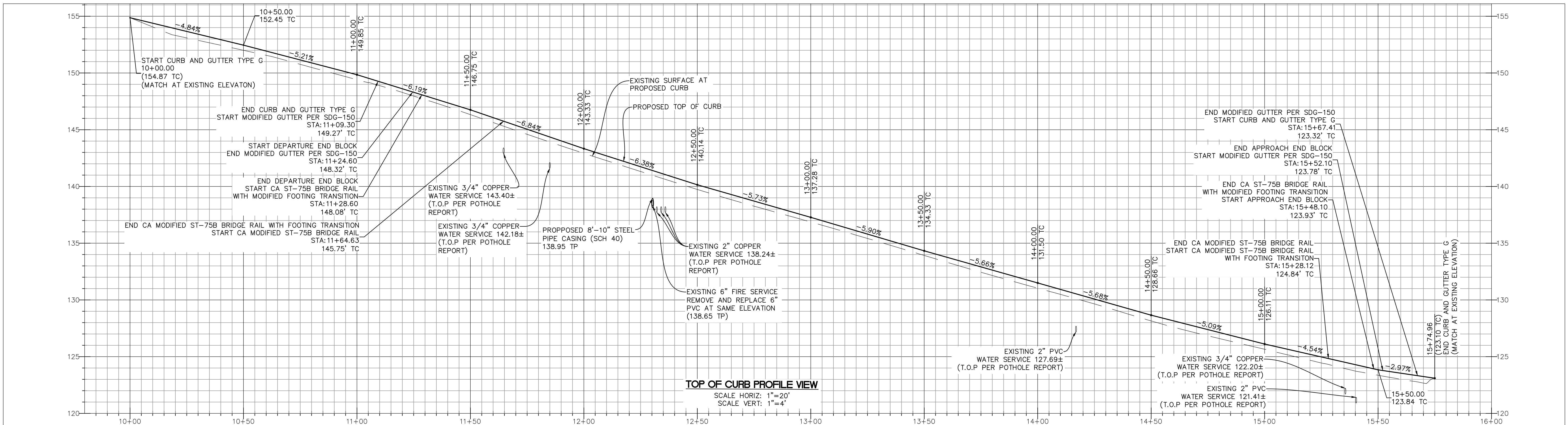

**CONSTRUCTION NOTES**

- 1) INSTALL CONCRETE SIDEWALK PER SDG-155.
- 2) INSTALL 6" CONCRETE CURB AND GUTTER TYPE G PER SDG-151.
- 3) REMOVE EXISTING ACC/PCC SECTION. CONSTRUCT PAVEMENT SECTION PER SDG-113 SCHEDULE J. (17.5" FULL DEPTH AC).
- 4) 2" GRIND AND VARIABLE OVERLAY TORREY PINES ROAD PER SDG-106 TYPE B. (WIDTH=3.0').
- 5) FURNISH AND INSTALL CALIFORNIA MODIFIED ST-75B BRIDGE RAIL PER CALTRANS REVISED STANDARD PLAN RSP B11-201, AND DETAIL ON SHEET C-1. LENGTH PER PLAN.
- 6) FURNISH AND INSTALL END BLOCK PER CALTRANS REVISED STANDARD PLAN RSP B11-201 AND B11-202.
- 7) FURNISH AND INSTALL TAU-M TO ST-75B BLOCK END (CRASH CUSHION) PER DETAIL ON SHEET 3 TAU-M (PART NUMBER 1835862) OR APPROVED EQUAL.
- 8) INSTALL MODIFIED CONCRETE GUTTER PER SDG-150. SEE SECTIONS A-A AND D-D FOR DETAILS.
- 9) INSTALL MODIFIED ST-75B BRIDGE RAIL WITH MODIFIED FOOTING TRANSITION PER SECTION B-B ON SHEET 3.
- 10) CONTRACTOR TO RELOCATE EXISTING WATER SERVICE PER WATER SERVICE RELOCATION DETAIL ON SHEET 4.
- 11) RELOCATE PRIVATE IRRIGATION SYSTEM HEADS BEHIND PROPOSED SIDEWALK. (L=600 LF).
- 12) EXISTING WATER METER BOX TO BE REMOVED AND REPLACED PER SDW-134 AND SDW-136.
- 14) INSTALL TYPE A GRAVITY WALL PER SDC C-09. SEE DETAIL ON SHEET 3.
- 15) INSTALL PEDESTRIAN BARRICADE PER SDG-141.
- 16) INSTALL VINYL COATED CHAINLINK FENCE IN KIND.
- 17) EXISTING TRAFFIC SIGNAL PULLBOX TO BE REMOVED AND REPLACED.
- 19) INSTALL FOOTING TRANSITION OVER FIRE SERVICE AND WATER SERVICES. SEE DETAIL ON SHEET 4.

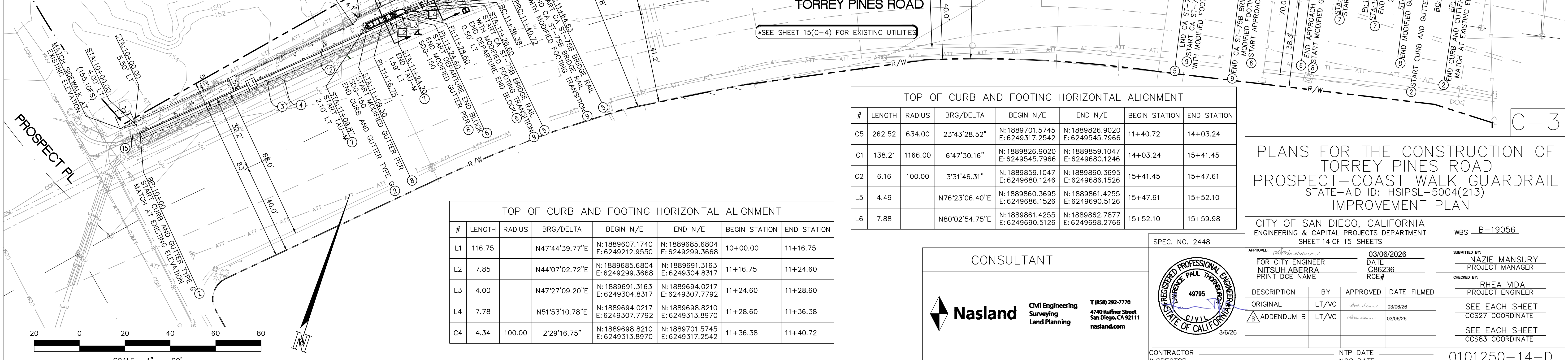

**TOP OF CURB AND FOOTING HORIZONTAL ALIGNMENT**

#	LENGTH	RADIUS	BRG/DELTA	BEGIN N/E	END N/E	BEGIN STATION	END STATION
L1	116.75		N47°44'39.77"E	N: 1889607.1740 E: 6249212.9550	N: 1889685.6804 E: 6249299.3668	10+00.00	11+16.75
L2	7.85		N44°07'02.72"E	N: 1889685.6804 E: 6249299.3668	N: 1889691.3163 E: 6249304.8317	11+16.75	11+24.60
L3	4.00		N47°27'09.20"E	N: 1889691.3163 E: 6249304.8317	N: 1889694.0217 E: 6249307.7792	11+24.60	11+28.60
L4	7.78		N51°53'10.78"E	N: 1889694.0217 E: 6249307.7792	N: 1889698.8210 E: 6249313.8970	11+28.60	11+36.38
C4	4.34	100.00	2°29'16.75"	N: 1889698.8210 E: 6249313.8970	N: 1889701.5745 E: 6249317.2542	11+36.38	11+40.72

**TOP OF CURB AND FOOTING HORIZONTAL ALIGNMENT**

#	LENGTH	RADIUS	BRG/DELTA	BEGIN N/E	END N/E	BEGIN STATION	END STATION
C5	262.52	634.00	23°43'28.52"	N: 1889701.5745 E: 6249317.2542	N: 1889826.9020 E: 6249545.7966	11+40.72	14+03.24
C1	138.21	1166.00	6°47'30.16"	N: 1889826.9020 E: 6249545.7966	N: 1889859.1047 E: 6249680.1246	14+03.24	15+41.45
C2	6.16	100.00	3°31'46.31"	N: 1889859.1047 E: 6249680.1246	N: 1889860.3695 E: 6249686.1526	15+41.45	15+47.61
L5	4.49		N76°23'06.40"E	N: 1889860.3695 E: 6249686.1526	N: 1889861.4255 E: 6249690.5126	15+47.61	15+52.10
L6	7.88		N80°02'54.75"E	N: 1889861.4255 E: 6249690.5126	N: 1889862.7877 E: 6249698.2766	15+52.10	15+59.98

**CONSULTANT**

**Nasland** Civil Engineering  
Surveying  
Land Planning

T (858) 292-7770  
4740 Ruffner Street  
San Diego, CA 92111  
nasland.com

SPEC. NO. 2448

REGISTERED PROFESSIONAL ENGINEER  
PAUL THORNTON  
49785  
STATE OF CALIFORNIA  
3/6/26

**PLANS FOR THE CONSTRUCTION OF TORREY PINES ROAD PROSPECT-COAST WALK GUARDRAIL IMPROVEMENT PLAN**

CITY OF SAN DIEGO, CALIFORNIA  
ENGINEERING & CAPITAL PROJECTS DEPARTMENT  
SHEET 14 OF 15 SHEETS

WBS\_B-19056

APPROVED: 03/06/2026  
FOR CITY ENGINEER: NITSUH ABERRA  
DATE: 03/06/26  
PROJECT MANAGER: NAZIE MANSURY  
RCE#: C86236

CHECKED BY: RHEA VIDA  
PROJECT ENGINEER

DESCRIPTION	BY	APPROVED	DATE	FILMED
ORIGINAL	LT/VC		03/06/26	
ADDENDUM B	LT/VC		03/06/26	

CONTRACTOR INSPECTOR: \_\_\_\_\_ NTP DATE: \_\_\_\_\_  
NO. DATE: \_\_\_\_\_

SEE EACH SHEET CCS27 COORDINATE  
SEE EACH SHEET CCS83 COORDINATE

0101250-14-D

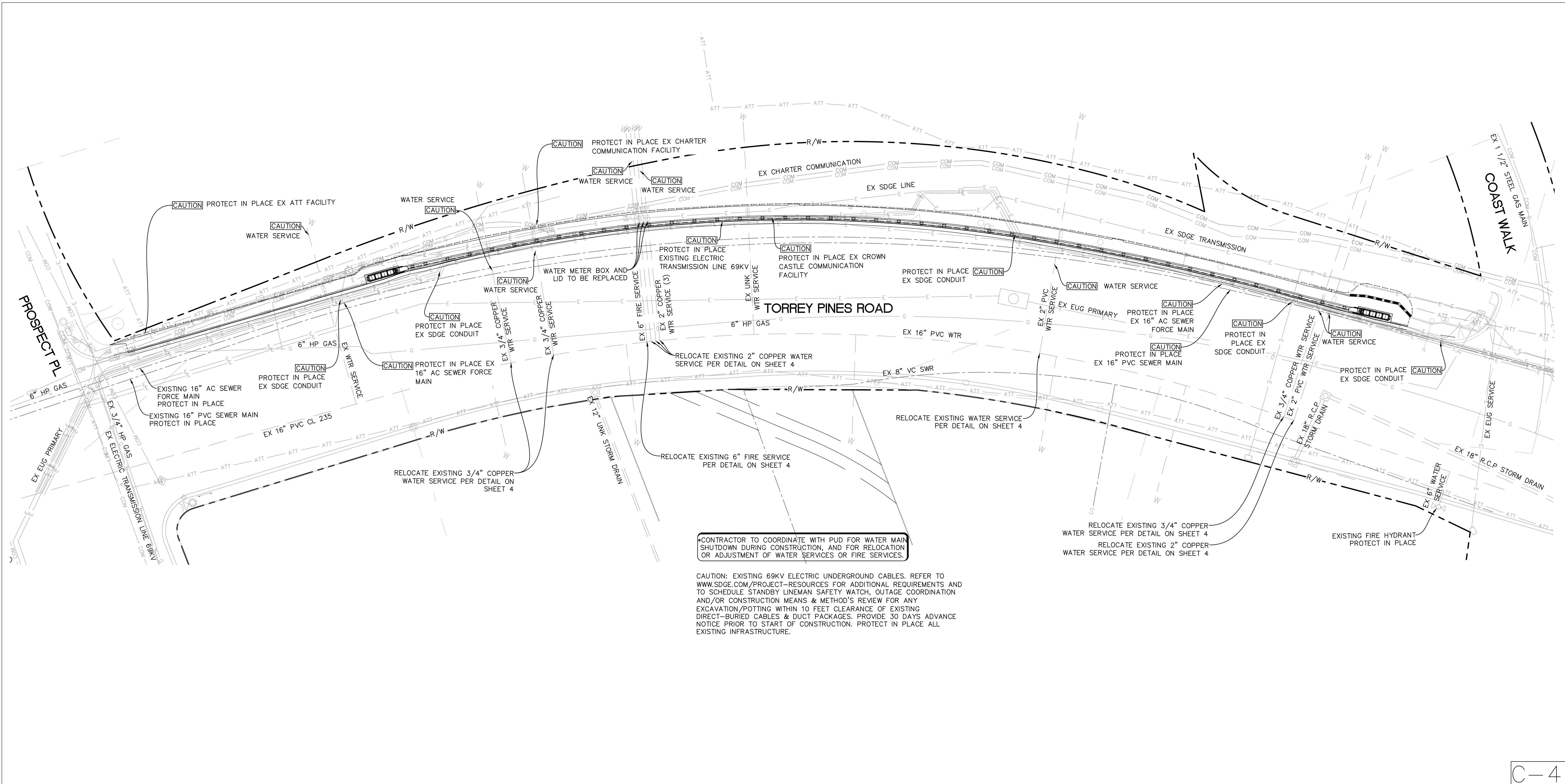

\*CONTRACTOR TO COORDINATE WITH PUD FOR WATER MAIN SHUTDOWN DURING CONSTRUCTION, AND FOR RELOCATION OR ADJUSTMENT OF WATER SERVICES OR FIRE SERVICES.

CAUTION: EXISTING 69KV ELECTRIC UNDERGROUND CABLES. REFER TO WWW.SDGE.COM/PROJECT-RESOURCES FOR ADDITIONAL REQUIREMENTS AND TO SCHEDULE STANDBY LINEMAN SAFETY WATCH, OUTAGE COORDINATION AND/OR CONSTRUCTION MEANS & METHOD'S REVIEW FOR ANY EXCAVATION/POTTING WITHIN 10 FEET CLEARANCE OF EXISTING DIRECT-BURIED CABLES & DUCT PACKAGES. PROVIDE 30 DAYS ADVANCE NOTICE PRIOR TO START OF CONSTRUCTION. PROTECT IN PLACE ALL EXISTING INFRASTRUCTURE.

UTILITY PLAN

C-4

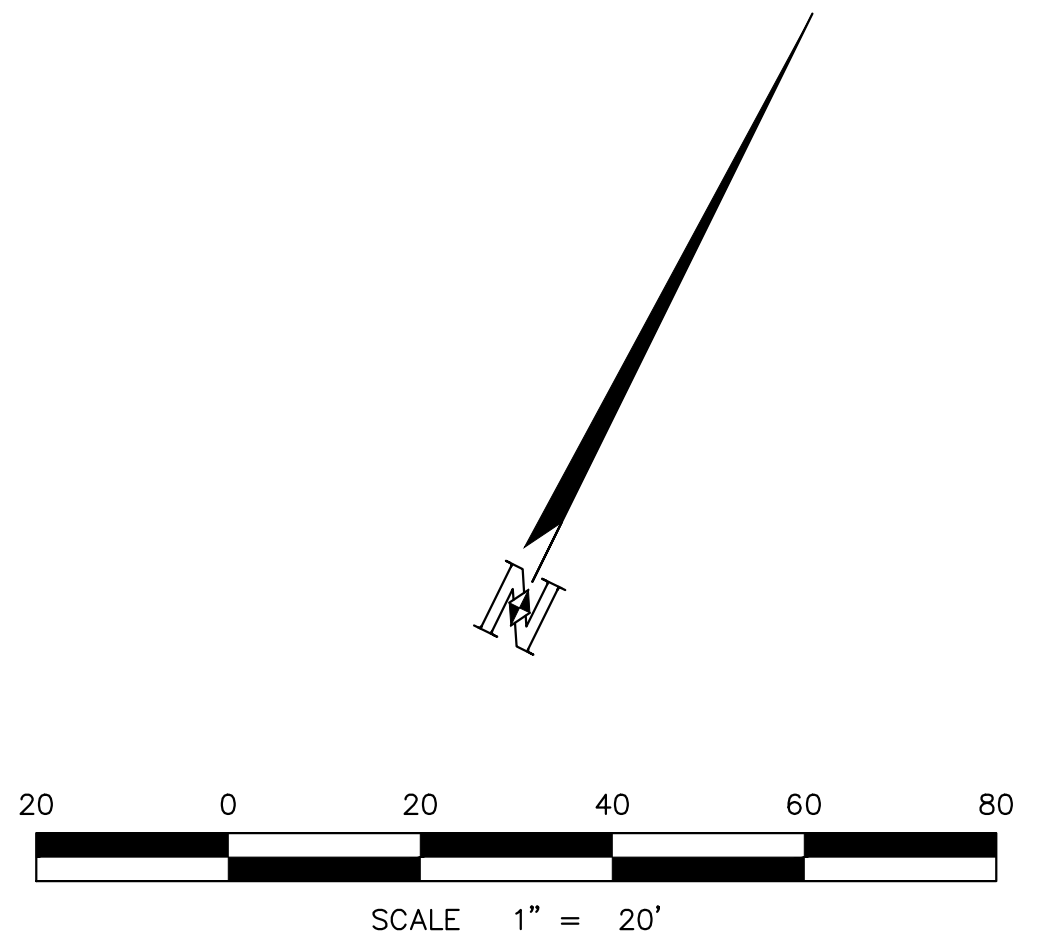

PLANS FOR THE CONSTRUCTION OF  
TORREY PINES ROAD  
PROSPECT-COAST WALK GUARDRAIL  
STATE-AID ID: HSIPSL-5004(213)  
UTILITY PLAN

CITY OF SAN DIEGO, CALIFORNIA ENGINEERING & CAPITAL PROJECTS DEPARTMENT SHEET 15 OF 15 SHEETS		WBS <u>B-19056</u>	
APPROVED: FOR CITY ENGINEER NITSUH ABERRA PRINT DCE NAME	DATE 03/06/2026 C86236 RCE#	SUBMITTED BY: NAZIE MANSURY PROJECT MANAGER	
DESCRIPTION		BY	APPROVED
ORIGINAL	LT/VC	<i>[Signature]</i>	03/06/26
ADDENDUM B	LT/VC	<i>[Signature]</i>	03/06/26
CONTRACTOR INSPECTOR		NTP DATE NOC DATE	
		0101250-15-D	

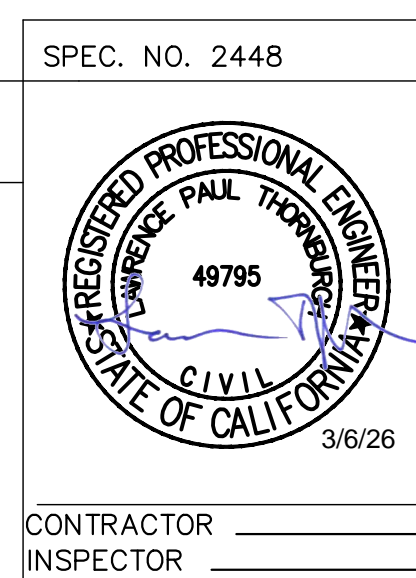

CONSULTANT

**Nasland** Civil Engineering  
Surveying  
Land Planning

T (858) 292-7770  
4740 Ruffner Street  
San Diego, CA 92111  
nasland.com

## Bid Result

### Bidder Details

**Vendor Name** Palm Engineering Construction Co., Inc.  
**Address** 7330 Opportunity Rd.. Suite A&B  
San Diego, CA, California 92111  
United States  
**Respondee** Estimating  
**Respondee Title** Project Engineer  
**Phone** 619-291-1495  
**Email** mo@palmengineeringco.com  
**Vendor Type** MALE, CADIR  
**License #** 853930  
**CADIR** 2000000411

### Bid Detail

**Bid Format** Electronic  
**Submitted** 03/17/2026 1:59 PM (PDT)  
**Delivery Method**  
**Bid Responsive**  
**Bid Status** Submitted  
**Confirmation #** 474301

### Respondee Comment

### Buyer Comment

### Attachments

File Title	File Name	File Type
1.Contractors Certification of Pending Actions.pdf	1.Contractors Certification of Pending Actions.pdf	Contractor's Certification of Pending Actions
2.Mandatory Disclosure of Business Interests Form.pdf	2.Mandatory Disclosure of Business Interests Form.pdf	Mandatory Disclosure of Business Interests Form
3.Prime Contractor - Debarment and Suspension Certification.pdf	3.Prime Contractor - Debarment and Suspension Certification.pdf	Prime Contractor - Debarment and Suspension Certification
4.Subcontractor - Debarment and Suspension Certification.pdf	4.Subcontractor - Debarment and Suspension Certification.pdf	Subcontractor - Debarment and Suspension Certification
5.Bid Bond.pdf	5.Bid Bond.pdf	Bid Bond

## Subcontractors

*Showing 2 Subcontractors*

Name & Address	Desc	License Num	CADIR	Amount	Type
<p><b>*Perry Electric</b>                      P.O. Box 710130                      Santee, California 92072</p>	<p>Electrical Work.                      (Constructor)</p>	<p>747931</p>	<p>1000012332</p>	<p>\$11,000.00</p>	<p>Local</p>
<p><b>Precision Striping Inc</b>                      545 W Bradley Ave                      El Cajon, California 92020</p>	<p>Striping.                      (Constructor)</p>	<p>1026547</p>	<p>1000051515</p>	<p>\$22,000.00</p>	<p>Local</p>

## Line Items

Discount Terms No Discount

Item #	Item Code	Type	Item Description	UOM	QTY	Unit Price	Line Total	Response	Comment
<b>Main Bid</b>							<b>\$1,313,226.00</b>		
1	524126		Bonds (Payment and Performance)	LS	1	\$30,000.00	\$30,000.00	Yes	
2	237310		Mobilization	LS	1	\$65,000.00	\$65,000.00	Yes	
3			Field Orders (EOC Type II)	AL	1	\$50,000.00	\$50,000.00	Yes	
4	238910		Clearing and Grubbing (Including All Demolition)	LS	1	\$50,000.00	\$50,000.00	Yes	
5	238910		Class 2 Aggregate Base	TON	120	\$115.00	\$13,800.00	Yes	
6	237310		Asphalt Concrete (Full Depth)	TON	65	\$250.00	\$16,250.00	Yes	
7	237310		Asphalt Concrete Overlay (Variable, 2 Inch Min)	TON	25	\$633.00	\$15,825.00	Yes	
8	237310		Curb and Gutter (6 Inch Curb, Type G)	LF	120	\$133.00	\$15,960.00	Yes	
9	237310		Gutter (Modified)	LF	32	\$233.00	\$7,456.00	Yes	
10	237310		Concrete Sidewalk	SF	2700	\$21.00	\$56,700.00	Yes	
11	237310		Black Vinyl Coated Chain Link Fence	LF	50	\$155.00	\$7,750.00	Yes	
12	237310		Bridge Railing (ST-75B)	LS	1	\$619,700.00	\$619,700.00	Yes	
13	237310		End Block	EA	2	\$6,500.00	\$13,000.00	Yes	
14	237310		Crash Cushion	EA	2	\$40,300.00	\$80,600.00	Yes	
15	237310		Removal and Replacement of Existing Paint Striping	LS	1	\$9,500.00	\$9,500.00	Yes	
16	237310		Paint Striping	LS	1	\$6,500.00	\$6,500.00	Yes	
17	237310		Removal and Replacement of Existing Thermoplastic Traffic Striping and Markings	LS	1	\$6,500.00	\$6,500.00	Yes	
18	237310		Thermoplastic Traffic Striping	LS	1	\$5,000.00	\$5,000.00	Yes	
19	237310		Thermoplastic Pavement Markings	LS	1	\$5,000.00	\$5,000.00	Yes	
20	237110		Meter Box	EA	10	\$730.00	\$7,300.00	Yes	
21	237110		6" PVC Fire Service with Steel Casing	LF	8	\$950.00	\$7,600.00	Yes	
22	237110		Relocate Water Service (3/4 Inch Copper)	EA	3	\$3,500.00	\$10,500.00	Yes	
23	237110		Relocate Water Service (2 Inch Copper)	EA	3	\$3,500.00	\$10,500.00	Yes	
24	237110		Relocate Water Service (2 Inch PVC)	EA	2	\$4,000.00	\$8,000.00	Yes	
25	237310		Pull Box	EA	3	\$935.00	\$2,805.00	Yes	
26	237310		Pedestrian Barricade	EA	2	\$1,800.00	\$3,600.00	Yes	
27	237310		Cold Mill AC Pavement (2 Inch)	SF	2100	\$5.00	\$10,500.00	Yes	
28	237310		Traffic Signal Loop and Appurtenance Replacement	LS	1	\$20,000.00	\$20,000.00	Yes	
29	237310		Flashing Arrow Boards	EA	1	\$6,500.00	\$6,500.00	Yes	
30	237310		Traffic Control	LS	1	\$45,000.00	\$45,000.00	Yes	
31	238210		Traffic Roadway Signage	LS	1	\$7,500.00	\$7,500.00	Yes	
32	541330		WPCP Development	LS	1	\$5,500.00	\$5,500.00	Yes	
33	237310		WPCP Implementation	LS	1	\$55,000.00	\$55,000.00	Yes	
34	238990		Video Recording of Existing Conditions	LS	1	\$3,500.00	\$3,500.00	Yes	
35	238110		Concrete Gravity Wall	CF	60	\$133.00	\$7,980.00	Yes	
36	561730		Irrigation System Relocation	LS	1	\$20,000.00	\$20,000.00	Yes	
37	237310		Temporary Noise Attenuation Barrier	LF	300	\$23.00	\$6,900.00	Yes	

### Line Item Subtotals

Section Title	Line Total
<b>Main Bid</b>	<b>\$1,313,226.00</b>
<b>Grand Total</b>	<b>\$1,313,226.00</b>

**SUBCONTRACTOR LISTING (OTHER THAN FIRST TIER)**

Pursuant to California Senate Bill 96 and in accordance with the requirements of Labor Code sections 1771.1 and 1725.5, by submitting a bid or proposal to the City, Contractor is certifying that he or she has verified that all subcontractors used on this public work project are registered with the California Department of Industrial Relations (DIR). **The Bidder is to list below the name, address, license number, DIR registration number of any (known tiered subcontractor)** - who will perform work, labor, render services or specially fabricate and install a portion [type] of the work or improvement pursuant to the contract. **If none are known at this time, mark the table below with non-applicable (N/A).**

Prime Contractor Name: Palm Engineering Construction Company, Inc.

NAME, ADDRESS AND TELEPHONE NUMBER OF SUBCONTRACTOR	CONSTRUCTOR OR DESIGNER	DIR REGISTRATION NUMBER	SUBCONTRACTOR LICENSE NUMBER	TYPE OF WORK
Name: <u>None</u> Address: _____ City: _____ State: _____ Zip: _____ Phone: _____ Email: _____				
Name: _____ Address: _____ City: _____ State: _____ Zip: _____ Phone: _____ Email: _____				
Name: _____ Address: _____ City: _____ State: _____ Zip: _____ Phone: _____ Email: _____				
Name: _____ Address: _____ City: _____ State: _____ Zip: _____ Phone: _____ Email: _____				

**\*\* USE ADDITIONAL FORMS AS NECESSARY \*\***