

**GATE WELLS (GATE VALVES)**

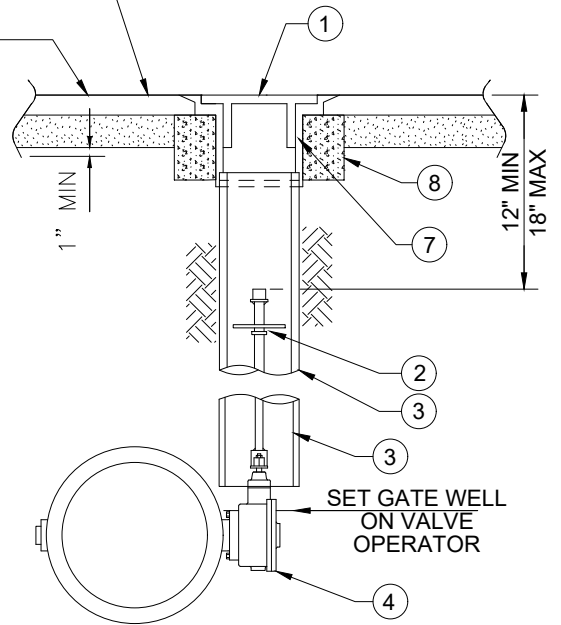

**GATE WELLS (BUTTERFLY VALVES)**

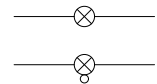

LEGEND ON PLANS

SEE ADDITIONAL NOTES ON SHEET 2

SHEET 1 OF 2

ITEM NO	SIZE AND DESCRIPTION	ITEM NO	SIZE AND DESCRIPTION
①	GATE WELL WITH CAP PER <b>SDW-152</b>	①	WATER MAIN
②	STAINLESS STEEL VALVE STEM EXTENSION SEE NOTES 1 & 2	②	VALVE WELL FRAME SET TO SLOPE OF SLOPE 9" X
③	8" ODx1/8" STEEL CASING AND REQUIRED LENGTH	③	9" CONCRETE RING
④	BUTTERFLY VALVE		
⑤	RESILIENT WEDGE GATE VALVE		

REVISION	BY	APPROVED	DATE	CITY OF SAN DIEGO – STANDARD DRAWING	RECOMMENDED BY THE CITY OF SAN DIEGO STANDARDS COMMITTEE
ORIGINAL*	KA	J. NAGELVOORT	01/12		
UPDATED	HM	J. NAGELVOORT	02/16	<b>GATE WELL CAP &amp; CAN INSTALLATION FOR VALVES 4" AND LARGER</b>	<i>Alaine James 05/29/2026</i>
UPDATED	EF	J. NAGELVOORT	11/17		COORDINATOR R.C.E. 81047 DATE
REDRAFTED	CD	J. NAGELVOORT	09/18		
UPDATED	NB	J. NAGELVOORT	05/21		
UPDATED	RC	R. AMEN	05/26		
				DRAWING NUMBER	<b>SDW-153</b>

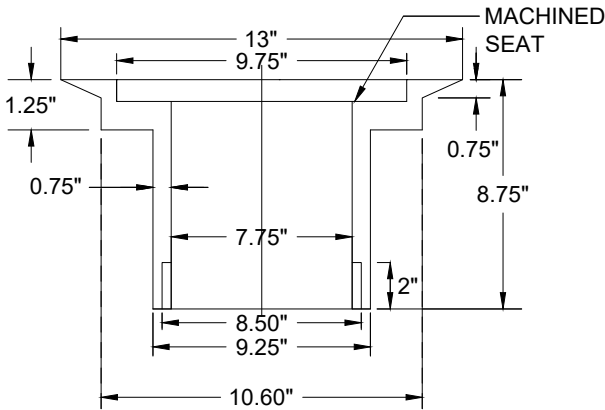

**CAST IRON VALVE WELL FRAME**

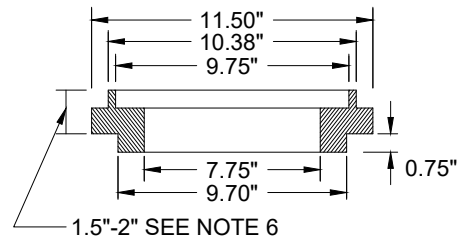

**CAST IRON RISER RING**

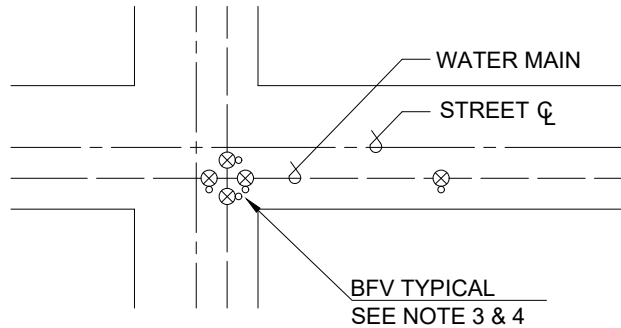

**BFV OPERATOR POSITION**

**NOTES:**

1. VALVES DEEPER THAN 6' REQUIRE A STAINLESS STEEL VALVE STEM EXTENSION.
2. EXTENSION STEMS SHALL NOT BE ATTACHED/ BOLTED TO OPERATING NUT.
3. GATE WELL AND CAP SHALL BE SET SO THAT NO MORE THAN TWO 1" ADJUSTMENT RINGS ARE USED.
4. BFV OPERATORS TO BE LOCATED TO THE CURBLINE SIDE OF WATER MAIN.
5. BFV'S INSTALLED AT CROSSES OR TEES REQUIRE A FLANGED DUCTILE IRON SPOOL TO BE INSTALLED BETWEEN THE FITTING AND VALVE IN ACCORDANCE WITH THE SPECIFICATIONS.
6. CAST IRON RISER RING HEIGHT TO MATCH OVERLAY THICKNESS, NO MORE THAN TWO (2) RINGS ARE USED.
7. CONCRETE RING MUST HAVE A DESIGN MIX OF 560-C-3250, AND OBTAIN 3250 PSI BEFORE TRAFFIC USE. SEE **SDG-108** NOTE 5 FOR CONCRETE OPTIONS AND CURING REQUIREMENTS.
8. USE NON-METALLIC SPACERS TO PREVENT CONTACT BETWEEN VALVE AND GATEWELL.

SHEET 2 OF 2

REVISION	BY	APPROVED	DATE	CITY OF SAN DIEGO – STANDARD DRAWING	RECOMMENDED BY THE CITY OF SAN DIEGO STANDARDS COMMITTEE	
ORIGINAL*	KA	J. NAGELVOORT	01/12		<b>GATE WELL CAP &amp; CAN INSTALLATION FOR VALVES 4" AND LARGER</b>	<i>Alaine James 5/29/2026</i>
UPDATED	HM	J. NAGELVOORT	02/16	COORDINATOR R.C.E. 81047 DATE		
UPDATED	EF	J. NAGELVOORT	11/17	DRAWING NUMBER		<b>SDW-153</b>
REDRAFTED	CD	J. NAGELVOORT	09/18			
UPDATED	NB	J. NAGELVOORT	05/21			
UPDATED	RC	R. AMEN	05/26			