

GEOTECHNICAL INVESTIGATION

STRAUSS FIFTH AVENUE APARTMENTS SAN DIEGO, CALIFORNIA



GEOCON
INCORPORATED

GEOTECHNICAL
ENVIRONMENTAL
MATERIALS

PREPARED FOR

**DANUBE PROPERTIES INCORPORATED
SAN DIEGO, CALIFORNIA**

**MAY 8, 2015
PROJECT NO. G1815-11-01**



Project No. G1815-11-01
May 8, 2015

Danube Properties Incorporated
2055 Third Avenue, Suite 200
San Diego, California 92101

Attention: Mr. Don Clauson

Subject: GEOTECHNICAL INVESTIGATION
STRAUSS FIFTH AVENUE APARTMENTS
SAN DIEGO, CALIFORNIA

Dear Mr. Clauson:

In accordance with your authorization of our Proposal No. LG-15061, dated February 24, 2015, we herein submit the results of our geotechnical investigation for the subject project. We performed our investigation to evaluate the underlying soil and geologic conditions and potential geologic hazards and to assist in the design of the proposed building and improvements. The accompanying report presents the results of our study and conclusions and recommendations pertaining to the geotechnical aspects of the proposed project. The site is considered suitable for the proposed building and improvements provided the recommendations of this report are incorporated into the design and construction of the planned project.

Should you have questions regarding this report, or if we may be of further service, please contact the undersigned at your convenience.

Very truly yours,

GEOCON INCORPORATED

Arnold Gastelum
RCE 81553

John Hoops
CEG 1524

Shawn Foy Weedon
GE 2714

AG:JH:SFW:dmc
(e-mail) Addressee



TABLE OF CONTENTS

1.	PURPOSE AND SCOPE	1
2.	SITE AND PROJECT DESCRIPTION	1
3.	GEOLOGIC SETTING.....	2
4.	SOIL AND GEOLOGIC CONDITIONS	2
4.1	Undocumented Fill (Qudf)	3
4.2	Very Old Paralic Deposits (Qvop).....	3
4.3	San Diego Formation (Tsd)	3
5.	GROUNDWATER	3
6.	GEOLOGIC HAZARDS	4
6.1	Geologic Hazard Category	4
6.2	Faulting and Seismicity	4
6.3	Ground Rupture	6
6.4	Seiches and Tsunamis.....	6
6.5	Liquefaction.....	7
6.6	Landslides.....	7
7.	CONCLUSIONS AND RECOMMENDATIONS.....	8
7.1	General.....	8
7.2	Excavation and Soil Conditions.....	8
7.3	Seismic Design Criteria	10
7.4	Grading	11
7.5	Excavation Slopes, Shoring, and Tiebacks.....	12
7.6	Soil Nail Wall	16
7.7	Conventional Shallow Foundations.....	17
7.8	Concrete Slabs-on-Grade.....	18
7.9	Concrete Flatwork	19
7.10	Preliminary Rigid Pavement Recommendations	20
7.11	Retaining Walls	22
7.12	Lateral Loading.....	23
7.13	Site Drainage and Moisture Protection.....	24
7.14	Grading and Foundation Plan Review	25

LIMITATIONS AND UNIFORMITY OF CONDITIONS

MAPS AND ILLUSTRATIONS

- Figure 1, Vicinity Map
- Figure 2, Geologic Map
- Figure 3, Geologic Cross-Section A-A'
- Figure 4, Geologic Cross-Section B-B'
- Figure 5, Lateral Active Pressures for Vertical Excavations
- Figure 6, Recommended Grouted Soldier Pile Pressure Distribution
- Figure 7, Recommended Effective Zone for Tieback Anchors
- Figure 8, Wall/Column Footing Dimension Detail
- Figure 9, Typical Retaining Wall Drain Detail
- Figure 10, Soldier Pile Wall Drainage Detail

TABLE OF CONTENTS (Concluded)

APPENDIX A

FIELD INVESTIGATION

Figures A-1 – A-4, Logs of Exploratory Borings

Geotechnical Boring Construction Permit, County of San Diego Dept. of Environmental Health

APPENDIX B

LABORATORY TESTING

Table B-I, Summary of Laboratory Maximum Dry Density and Optimum Moisture Content Test Results

Table B-II, Summary of Laboratory Direct Shear Test Results

Table B-III, Summary of Laboratory Expansion Index Test Results

Table B-IV, Summary of Laboratory Water-Soluble Sulfate Test Results

Table B-V, Summary of Laboratory Potential of Hydrogen (pH) and Resistivity Test Results

Table B-VI, Summary of Laboratory Water-Soluble Chloride Ion Content Test Results

Table B-VII, Summary of In-Situ Unconfined Compressive Strength Test Results

LIST OF REFERENCES

GEOTECHNICAL INVESTIGATION

1. PURPOSE AND SCOPE

This report presents the results of our geotechnical investigation for the proposed new apartment building over subterranean parking levels in the Hillcrest neighborhood of San Diego, California (see Vicinity Map, Figure 1). The purpose of this geotechnical investigation is to evaluate the surface and subsurface soil conditions, general site geology, and to identify geotechnical constraints that may impact the planned improvements to the property. In addition, this report provides 2013 CBC seismic design criteria; grading recommendations; shoring, tie-back, and soil nail wall recommendations; building foundation and concrete slab-on-grade recommendations; concrete flatwork, preliminary rigid pavement recommendations; retaining wall, and lateral load recommendations; and discussion regarding the local geologic hazards including faulting and seismic shaking.

This report is limited to the area proposed for the construction of the new development and associated improvements as shown on the Geologic Map, Figure 2. We used an architectural site plan prepared by Carrier Johnson + Culture for the base of the Geologic Map.

The scope of this investigation included the review of readily available published and unpublished geologic literature (see List of References), drilling four exploratory borings to a maximum depth of about 61 feet, soil sampling, laboratory testing, engineering analyses, and preparation of this geotechnical investigation report. Appendix A presents the exploratory boring logs and details of the field investigation. Appendix B presents details of the laboratory tests and a summary of the test results.

2. SITE AND PROJECT DESCRIPTION

The roughly $\frac{3}{4}$ -acre site is located in a mixed use neighborhood. The site is bound by a 3-story office building with address 3500 Fifth Avenue to the south; an alleyway and residential buildings to the west; residential and retail buildings to the north; and Fifth Avenue on the east. The subject site currently consists of a one and two story apartment building located in the center portion of the subject site with two on-grade parking lots to the north and south of the apartment building. The asphalt concrete parking lots can be accessed from Fifth Avenue to the east and the alleyway to the west. The property slopes gently to the east roughly 4 to 5 feet with drainage sheet flowing toward Fifth Avenue.

The Strauss Fifth Avenue Apartments development will consist of a five- to six-story apartment building with three levels of subterranean parking. The building will also contain a workout center, leasing office, pool, and on-grade space adjacent to the existing office building. The excavations for

the subterranean parking will be vertical from the edges of the property and will not extend below the existing western alleyway, sidewalks along Fifth Avenue or the office building to the south.

The locations and descriptions of the site and proposed development are based discussions with you and observations during our field investigation. If project details vary significantly from those described herein, Geocon Incorporated should be contacted to evaluate the necessity for review and revision of this report.

3. GEOLOGIC SETTING

The site is located in a coastal plain environment within the southern portion of the Peninsular Ranges Geomorphic Province of southern California. The Peninsular Ranges is a geologic and geomorphic province that extends from the Imperial Valley to the Pacific Ocean and from the Transverse Ranges to the north and into Baja California to the south. The coastal plain of San Diego County is underlain by a thick sequence of relatively undisturbed and non-conformable sedimentary rocks that thicken to the west and range in age from Upper Cretaceous through the Pleistocene with intermittent deposition. The sedimentary units are deposited on bedrock Cretaceous- to Jurassic-age igneous and metavolcanic rocks. Geomorphically, the coastal plain is characterized by a series of twenty-one, stair-stepped marine terraces, which are younger to the west and have been dissected by west flowing rivers that drain the Peninsular Ranges to the east. The coastal plain is a relatively stable block that is dissected by relatively few faults consisting of the potentially active La Nacion Fault Zone and the active Rose Canyon Fault Zone. The Peninsular Ranges Province is also dissected by the Elsinore Fault Zone that is associated with and sub-parallel to the San Andreas Fault Zone, which is the plate boundary between the Pacific and North American Plates.

Marine and non-marine Pleistocene- and Pliocene-age shallow sedimentary units, consisting of Very Old Paralic Deposits (Unit 9) unconformably overlying the San Diego Formation, make up the geologic units present on the site. Geomorphically, the site is located on a marine terrace (Linda Vista) that has been dissected to the east by a canyon drainage east of Sixth Avenue likely formed during the Pleistocene-age. The surface elevations slope gently to the east toward the canyon drainage which flows through Balboa Park and into the San Diego Bay to the south. The terrace deposit is approximately 25 to 30 feet thick on site at an approximate elevation of 261 to 263 feet MSL overlying the San Diego Formation reported to be several hundred feet thick.

4. SOIL AND GEOLOGIC CONDITIONS

Our field investigation indicates the site is underlain by one surficial soil type (consisting of undocumented fill) and two geologic units (consisting of Very Old Paralic Deposits and the San Diego Formation). The boring logs presented in Appendix A and the Geologic Map, Figure 2, show the occurrence, distribution, and description of each unit encountered during our field investigation.

Figures 3 and 4 present Geologic Cross-Sections showing the approximate underlying geologic conditions. The surficial soil and geologic units are described herein in order of increasing age.

4.1 Undocumented Fill (Qudf)

We encountered undocumented fill in exploratory Borings B-1 through B-4 to a maximum depth of approximately 4 feet below existing ground surface. The fill generally consists of medium dense, reddish brown to dark brown, silty to clayey sand with varying amounts of gravel. The undocumented fill is considered unsuitable for support of the proposed building. We expect the fill materials will be removed during excavations to achieve finish grade elevations for the subterranean parking garage. Undocumented fill exposed at finish grade will require processing to support hardscape improvements. The fill material can be reused as properly compacted new fill if relatively free from vegetation, debris, and contaminants.

4.2 Very Old Paralic Deposits (Qvop)

Middle to early Pleistocene-age Very Old Paralic Deposits underlies the undocumented fill. Very Old Paralic Deposits consists of very dense, moderately cemented, reddish-brown to yellowish-brown, silty to clayey, fine- to coarse-grained sandstone with zones of gravel and cobble. In general, the deposits possess a “very low” to “low” expansion potential (Expansion Index of 50 or less) and suitable shear strengths. Very Old Paralic Deposits are considered suitable for the support of compacted fill and/or structural loads. Excavations within this unit will likely encounter difficult digging conditions and oversize material may be generated.

4.3 San Diego Formation (Tsd)

Pliocene-age San Diego Formation underlies the Very Old Paralic Deposits. We encountered the San Diego Formation at depths ranging from approximately 26 to 32 feet below the existing ground surface or at approximate elevations of 260.5 to 262.5 feet MSL. The San Diego Formation consists of very dense, weakly cemented, silty, fine-grained sandstone. In general, the deposit possesses a “very low” to “low” expansion potential (Expansion Index of 50 or less) and suitable shear strengths. The San Diego Formation is considered suitable for support of structural loads. Excavations in this unit will likely require moderate to heavy effort with conventional heavy-duty equipment, and oversize materials may be generated in localized areas if cemented zones are encountered. Some areas of caving sand may also be encountered within the San Diego Formation.

5. GROUNDWATER

We did not encounter groundwater or seepage during the site investigation. We expect the groundwater table would be in excess of 100 to 150 feet below existing ground. We do not expect groundwater or seepage to be encountered during construction of the proposed development.

However, it is not uncommon for seepage conditions to exist within the near surface elevations or develop where none previously existed. Seepage is dependent on seasonal precipitation, irrigation, land use, among other factors, and varies as a result. Proper surface drainage will be important to future performance of the project.

6. GEOLOGIC HAZARDS

6.1 Geologic Hazard Category

The City of San Diego Seismic Safety Study, Geologic Hazards and Faults, Map Sheet 21 defines the site with a *Hazard Category 52 Other Terrain: Other level areas, gently sloping to steep terrain, favorable geologic structure. Low risk.*

6.2 Faulting and Seismicity

Review of the referenced geologic materials and our knowledge of the general area indicate that the site is not underlain by active, potentially active, or inactive faulting. An active fault is defined by the California Geological Survey (CGS) as a fault showing evidence for activity within the last 11,000 years. The site is not located within State of California Earthquake Fault Zone. In addition to our background review, the site is not mapped in the vicinity of geologic hazards such as landslides or liquefaction areas. The potentially active Florida Canyon Fault is located approximately 1 mile to the east and the potentially active Texas Street Fault is located approximately 1½ miles to the east. These faults will not affect site development of the project.

According to the computer program *EZ-FRISK* (Version 7.65), six known active faults are located within a search radius of 50 miles from the property. We used the 2008 USGS fault database that provides several models and combinations of fault data to evaluate the fault information. Based on this database, the nearest known active fault is the Newport-Inglewood/Rose Canyon Faults, located approximately 1 mile west of the site and is the dominant source of potential ground motion. Earthquakes that might occur on the Newport-Inglewood/Rose Canyon Faults or other faults within the southern California and northern Baja California area are potential generators of significant ground motion at the site. The estimated deterministic maximum earthquake magnitude and peak ground acceleration for the Newport-Inglewood/Rose Canyon Faults are 7.5 and 0.60g, respectively. Table 6.2.1 lists the estimated maximum earthquake magnitude and peak ground acceleration for the most dominant faults in relationship to the site location. We calculated peak ground acceleration (PGA) using Boore-Atkinson (2008) NGA USGS 2008, Campbell-Bozorgnia (2008) NGA USGS 2008, and Chiou-Youngs (2007) NGA USGS 2008 acceleration-attenuation relationships. The subject site can be classified as Site Class C.

**TABLE 6.2.1
DETERMINISTIC SPECTRA SITE PARAMETERS**

Fault Name	Distance from Site (miles)	Maximum Earthquake Magnitude (Mw)	Peak Ground Acceleration		
			Boore-Atkinson 2008 (g)	Campbell-Bozorgnia 2008 (g)	Chiou-Youngs 2007 (g)
Newport-Inglewood	1	7.5	0.51	0.47	0.60
Rose Canyon	1	6.9	0.47	0.47	0.56
Coronado Bank	13	7.4	0.20	0.16	0.19
Palos Verdes Connected	13	7.7	0.22	0.17	0.22
Elsinore	40	7.85	0.11	0.08	0.10
Earthquake Valley	45	6.8	0.06	0.05	0.04

We used the computer program *EZ-FRISK* to perform a probabilistic seismic hazard analysis. The computer program *EZ-FRISK* operates under the assumption that the occurrence rate of earthquakes on each mappable Quaternary fault is proportional to the faults slip rate. The program accounts for fault rupture length as a function of earthquake magnitude, and site acceleration estimates are made using the earthquake magnitude and distance from the site to the rupture zone. The program also accounts for uncertainty in each of following: (1) earthquake magnitude, (2) rupture length for a given magnitude, (3) location of the rupture zone, (4) maximum possible magnitude of a given earthquake, and (5) acceleration at the site from a given earthquake along each fault. By calculating the expected accelerations from considered earthquake sources, the program calculates the total average annual expected number of occurrences of site acceleration greater than a specified value. We utilized acceleration-attenuation relationships suggested by Boore-Atkinson (2008) NGA USGS, Campbell-Bozorgnia (2008) NGA USGS, and Chiou-Youngs (2007) NGA USGS 2008 in the analysis. Table 6.2.2 presents the site-specific probabilistic seismic hazard parameters including acceleration-attenuation relationships and the probability of exceedence.

**TABLE 6.2.2
PROBABILISTIC SEISMIC HAZARD PARAMETERS**

Probability of Exceedence	Peak Ground Acceleration		
	Boore-Atkinson, 2008 (g)	Campbell-Bozorgnia, 2008 (g)	Chiou-Youngs, 2007 (g)
2% in a 50 Year Period	0.57	0.56	0.68
5% in a 50 Year Period	0.35	0.35	0.40
10% in a 50 Year Period	0.22	0.22	0.23

The California Geologic Survey (CGS) has a program that calculates the ground motion for a 10 percent of probability of exceedence in 50 years based on an average of several attenuation

relationships. Table 6.2.3 presents the calculated results from the Probabilistic Seismic Hazards Mapping Ground Motion Page from the CGS website.

**TABLE 6.2.3
PROBABILISTIC SITE PARAMETERS FOR SELECTED FAULTS
CALIFORNIA GEOLOGIC SURVEY**

Calculated Acceleration (g) Firm Rock	Calculated Acceleration (g) Soft Rock	Calculated Acceleration (g) Alluvium
0.27	0.29	0.33

While listing peak accelerations is useful for comparison of potential effects of fault activity in a region, other considerations are important in seismic design, including the frequency and duration of motion and the soil conditions underlying the site. Seismic design of the structures should be evaluated in accordance with the California Building Code (CBC) guidelines currently adopted by the City of San Diego.

6.3 Ground Rupture

Ground surface rupture occurs when movement along a fault is sufficient to cause a gap or rupture where the upper edge of the fault zone intersects the earth surface. The potential for ground rupture is considered to be negligible due to the absence of active faults at the subject site.

6.4 Seiches and Tsunamis

Seiches are free or standing-wave oscillations of an enclosed water body that continue, pendulum fashion, after the original driving forces have dissipated. Seiches usually propagate in the direction of longest axis of the basin. The potential of seiches to occur is considered to be very low due to the absence of a nearby inland body of water.

A tsunami is a series of long-period waves generated in the ocean by a sudden displacement of large volumes of water. Causes of tsunamis may include underwater earthquakes, volcanic eruptions, or offshore slope failures. The first-order driving force for locally generated tsunamis offshore southern California is expected to be tectonic deformation from large earthquakes. Wave heights and run-up elevations from tsunamis along the San Diego Coast have historically fallen within the normal range of the tides. The site is located approximately 4½ miles from the Pacific Ocean at an elevation of approximately 290 feet above Mean Sea Level; therefore, the risk of tsunamis affecting the site is negligible.

6.5 Liquefaction

Liquefaction typically occurs when a site is located in a zone with seismic activity, onsite soil is cohesionless or silt/clay with low plasticity, groundwater is encountered within 50 feet of the surface, and soil relative densities are less than about 70 percent. If the four of the previous criteria are met, a seismic event could result in a rapid pore-water pressure increase from the earthquake-generated ground accelerations. Seismically induced settlement may occur whether the potential for liquefaction exists or not. The potential for liquefaction and seismically induced settlement occurring within the site soil is considered very low due to the dense nature of the Very Old Paralic Deposits and San Diego Formation.

6.6 Landslides

Based on observations during our field investigation and review of published geologic maps for the site vicinity, it is our opinion that potential landslides are not present at the subject property or at a location that could impact the proposed development.

7. CONCLUSIONS AND RECOMMENDATIONS

7.1 General

- 7.1.1 From a geotechnical engineering standpoint, it is our opinion that the site is suitable for development of the five- to six-story apartment building with three levels of subterranean parking provided the recommendations presented herein are implemented in design and construction of the project.
- 7.1.2 With the exception of possible moderate to strong seismic shaking, no significant geologic hazards were observed or are known to exist on the site that would adversely affect the proposed project.
- 7.1.3 Our field investigation indicates the site is underlain by undocumented fill overlying Very Old Paralic Deposits and the San Diego Formation. The undocumented fill is not considered suitable for the support of the building structure. We expect the proposed subterranean garage finish grade elevations will be within the Very Old Paralic Deposits or the San Diego Formation.
- 7.1.4 The Very Old Paralic Deposits and the San Diego Formation are considered suitable for the support of compacted fill and settlement-sensitive structures.
- 7.1.5 Undocumented fill exposed at finish grade surrounding the building structure that will support new surface improvements will require the processing prior to placement of compacted fill or improvements.
- 7.1.6 We did not encounter groundwater or seepage during our field investigation. We do not expect groundwater or seepage to be encountered during construction of the proposed development.
- 7.1.7 The proposed structure can be supported on conventional shallow foundations founded in Very Old Paralic Deposits or the San Diego Formation.

7.2 Excavation and Soil Conditions

- 7.2.1 Excavation of the undocumented fill, the Very Old Paralic Deposits, and the San Diego Formation should generally be possible with moderate to heavy effort using conventional, heavy-duty equipment during grading and trenching operations. We expect very heavy effort with possible refusal for excavations into moderately cemented layers and gravel and cobble portions of the Very Old Paralic Deposits. Cemented layers within the San Diego

Formations are expected to be localized. Sidewall instability may be encountered where the cohesion of the materials is very low.

7.2.2 The soil encountered in our field investigation is predominately considered to be “non-expansive” (expansion index of 20 or less) as defined by 2013 California Building Code (CBC) Section 1803.5.3. Table 7.2.1 presents soil classifications based on the expansion index. Based on the results of our laboratory testing, presented in Appendix B, and observations during drilling operations, we expect the on-site materials will possess a “very low” to “low” expansion potential (Expansion Index of 50 or less).

**TABLE 7.2.1
EXPANSION CLASSIFICATION BASED ON EXPANSION INDEX**

Expansion Index (EI)	Expansion Classification	2013 CBC Expansion Classification
0 – 20	Very Low	Non-Expansive
21 – 50	Low	Expansive
51 – 90	Medium	
91 – 130	High	
Greater Than 130	Very High	

7.2.3 We performed laboratory tests on samples of the site materials to evaluate the percentage of water-soluble sulfate content. Appendix B presents the results from the laboratory water-soluble sulfate content tests. The test results indicate that on-site materials at the locations tested possess “Not Applicable” and “S0” sulfate exposure to concrete structures, as defined by 2013 CBC Section 1904 and ACI 318-08 Sections 4.2 and 4.3. The presence of water-soluble sulfates is not a visually discernible characteristic. Therefore, other soil samples from the site could yield different concentrations. Additionally, over time landscaping activities (i.e. addition of fertilizers and other soil nutrients) may affect the concentration. We should perform additional laboratory tests to evaluate the soil at existing grade subsequent to the grading operations.

7.2.4 We tested samples for potential of hydrogen (pH) and resistivity laboratory tests to aid in evaluating the corrosion potential to subsurface metal structures. The laboratory test results are presented in Appendix B.

7.2.5 Geocon Incorporated does not practice in the field of corrosion engineering. Therefore, further evaluation by a corrosion engineer may be performed if improvements that could be susceptible to corrosion are planned.

7.3 Seismic Design Criteria

7.3.1 We used the computer program *U.S. Seismic Design Maps*, provided by the USGS. Table 7.3.1 summarizes site-specific design criteria obtained from the 2013 California Building Code (CBC; Based on the 2012 International Building Code [IBC] and ASCE 7-10), Chapter 16 Structural Design, Section 1613 Earthquake Loads. The short spectral response uses a period of 0.2 second. The building structure and improvements should be designed using a Site Class C. We evaluated the Site Class based blow counts, unconfined compression tests, the discussion in Section 1613.3.2 of the 2013 CBC, and Table 20.3-1 of ASCE 7-10. The values presented in Table 7.3.1 are for the risk-targeted maximum considered earthquake (MCE_R).

**TABLE 7.3.1
2013 CBC SEISMIC DESIGN PARAMETERS**

Parameter	Value	2013 CBC Reference
Site Class	C	Table 1613.3.2
MCE_R Ground Motion Spectral Response Acceleration – Class B (short), S_S	1.154g	Figure 1613.3.1(1)
MCE_R Ground Motion Spectral Response Acceleration – Class B (1 sec), S_1	0.444g	Figure 1613.3.1(2)
Site Coefficient, F_A	1.000	Table 1613.3.3(1)
Site Coefficient, F_V	1.356	Table 1613.3.3(2)
Site Class Modified MCE_R Spectral Response Acceleration (short), S_{MS}	1.154g	Section 1613.3.3 (Eqn 16-37)
Site Class Modified MCE_R Spectral Response Acceleration – (1 sec), S_{M1}	0.602g	Section 1613.3.3 (Eqn 16-38)
5% Damped Design Spectral Response Acceleration (short), S_{DS}	0.769g	Section 1613.3.4 (Eqn 16-39)
5% Damped Design Spectral Response Acceleration (1 sec), S_{D1}	0.401g	Section 1613.3.4 (Eqn 16-40)

7.3.2 Table 7.3.2 presents additional seismic design parameters for projects located in Seismic Design Categories of D through F in accordance with ASCE 7-10 for the mapped maximum considered geometric mean (MCE_G).

**TABLE 7.3.2
2013 CBC SITE ACCELERATION DESIGN PARAMETERS**

Parameter	Value	ASCE 7-10 Reference
Mapped MCE_G Peak Ground Acceleration, PGA	0.508g	Figure 22-7
Site Coefficient, F_{PGA}	1.000	Table 11.8-1
Site Class Modified MCE_G Peak Ground Acceleration, PGA_M	0.508g	Section 11.8.3 (Eqn 11.8-1)

7.3.3 Conformance to the criteria in Tables 7.3.1 and 7.3.2 for seismic design does not constitute any kind of guarantee or assurance that significant structural damage or ground failure will not occur if a maximum level earthquake occurs. The primary goal of seismic design is to protect life and not to avoid all damage, since such design may be economically prohibitive.

7.4 Grading

7.4.1 A pre-construction conference with the city inspector, owner, general contractor, civil engineer, and soil engineer in attendance should be held at the site prior to the beginning of grading operations. Special soil handling requirements can be discussed at that time.

7.4.2 Earthwork should be observed and compacted fill tested by representatives of Geocon Incorporated.

7.4.3 Grading of the site should commence with the demolition of existing structures, pavement, removal of existing improvements, vegetation, and deleterious debris. Deleterious debris should be exported from the site and should not be mixed with the fill. Existing underground improvements within the proposed structure area should be removed and relocated.

7.4.4 Based on our field investigation, we expect excavations for the planned apartment building and subterranean parking garage will expose Very Old Paralac Deposits and the San Diego Formation. The excavations can be performed to finish grade for the subterranean parking level without performing additional grading operations. If the bottom of the excavation is disturbed during excavation and export operations, then processing and compaction of the finish grade soil will be required.

7.4.5 Undocumented fill will likely be exposed in areas of surface improvements surrounding the building. The upper 12 inches of the undocumented fill should be scarified, moisture

conditioned as necessary and properly compacted. The actual extent of processing should be evaluated in the field by a representative of Geocon Incorporated.

7.4.6 Fill and backfill materials should be compacted to a dry density of at least 90 percent of the laboratory maximum dry density near to slightly above optimum moisture content as determined by ASTM Test Method D 1557. The upper 12 inches of fill beneath pavement areas should be compacted to a dry density of at least 95 percent of the laboratory maximum dry density near to slightly above optimum moisture content shortly before paving operations.

7.4.7 Import fill (if necessary) should consist of granular materials with a “very low” to “low” expansion potential (EI of 50 or less) free of deleterious material or stones larger than 3 inches and should be compacted as recommended herein. Geocon Incorporated should be notified of the import source and should perform laboratory testing of import soil prior to its arrival at the site to evaluate its suitability as fill material.

7.5 Excavation Slopes, Shoring, and Tiebacks

7.5.1 The recommendations herein are provided for stable excavations and are submitted to the shoring and structural engineers to design a shoring system for the proposed excavations. The contractor should construct the temporary shoring system as designed by the project shoring engineer. The stability of the excavations is dependent on the design and construction of the shoring system. Therefore, Geocon Incorporated cannot be responsible for site safety and the stability of the proposed excavations. It is the responsibility of the contractor to provide a safe excavation during the construction of the proposed project.

7.5.2 Temporary slopes should be made in conformance with OSHA requirements. Undocumented fill should be considered a Type C soil, compacted fill should be considered a Type B soil (Type C soil if seepage is encountered) and the Very Old Parallic and San Diego Formation should be considered a Type A soil (Type B soil if seepage, groundwater, or cohesionless soil is encountered) in accordance with OSHA requirements. In general, no special shoring requirements will be necessary if temporary excavations will be less than 4 feet in height. Temporary excavations greater than 4 feet in height, however, should be sloped at an appropriate inclination. These excavations should not be allowed to become saturated or to dry appreciably. Surcharge loads should not be permitted to a distance equal to the height of the excavation from the top of the excavation. The top of the excavation should be a minimum of 15 feet from the edge of existing improvements. Excavations steeper than those recommended or closer than 15 feet from an existing surface improvement should be shored in accordance with applicable OSHA codes and regulations.

- 7.5.3 The design of temporary shoring is governed by soil and groundwater conditions and by the depth and width of the excavated area. Continuous support of the excavation face can be provided by a system of soldier piles and wood lagging. Excavations exceeding 15 feet may require tie back anchors or internal bracing to provide additional wall restraint.
- 7.5.4 In general, ground conditions are moderately suited to soldier pile and tieback anchor construction techniques. However, localized gravel, cobble, and cemented material will likely be encountered in the existing materials that could be difficult to drill. Additionally, relatively clean sands may be encountered within the existing materials that may result in some raveling of the unsupported excavation.
- 7.5.5 For level backfill conditions behind the shoring system, temporary tied-back shoring should be designed using a lateral pressure envelope acting on the back of the shoring and applying a pressure equal to $31H$, $20H$, or $25H$, for a triangular, rectangular, or trapezoidal distribution, respectively, where H is the height, in feet, of the shoring (resulting pressure in pounds per square foot) as shown in Figure 5. These values are based on estimated maximum wall heights of approximately 45 feet. Triangular distribution should be used for cantilevered shoring and the trapezoidal and rectangular distribution should be used for multi-braced systems such as tieback anchors and rakers. The project shoring engineer should determine the applicable soil distribution for the design of the temporary shoring system. Additional lateral earth pressure due to the surcharging effects of adjacent structures, soil, or traffic loads should be considered, where appropriate, during design of the shoring system.
- 7.5.6 Passive soil pressure resistance for embedded portions of soldier piles can be based upon an equivalent passive soil fluid weight of $500 + 375D$, where D is the depth of embedment (resulting in pounds per square foot), as shown on Figure 6. The passive resistance can be assumed to act over a width of three pile diameters. Typically, soldier piles are embedded a minimum of 0.5 times the maximum height of the excavation (this depth is to include footing excavations) if tieback anchors are not employed. The project structural engineer should determine the actual embedment depth.
- 7.5.7 Lateral movement of shoring is associated with vertical ground settlement outside of the excavation. Therefore, it is essential that the soldier pile and raker/tieback system only allow limited amounts of lateral displacement. Earth pressures acting on a lagging wall can result in the movement of the shoring toward the excavation and result in ground subsidence outside of the excavation. Consequently, horizontal movements of the shoring wall should be accurately monitored and recorded during excavation and anchor construction.

- 7.5.8 Survey points should be established at the top and at least one intermediate point between the top of the pile and the base of the excavation at least 20 percent of the soldier piles. These points should be monitored on a regular basis during excavation work.
- 7.5.9 The shoring system should be designed to limit horizontal and vertical soldier pile movement to a maximum of 1 inch and ½ inch, respectfully. The amount of horizontal deflection can be assumed to be essentially zero along the Active Zone and Effective Zone boundary. The magnitude of movement for intermediate depths and distances from the shoring wall can be linearly interpolated. Higher values of horizontal movement can be allowed if properly incorporated into the design of the shoring. The project civil and/or shoring engineer should determine the allowable amount of horizontal movement associated with the shoring system that could affect the existing utilities and structures.
- 7.5.10 If tieback anchor system is used, the tiebacks employed in shoring should be designed such that anchors fully penetrate the Active Zone behind the shoring. The Active Zone can be considered the wedge of soil from the face of the shoring to a plane extending upward from the base of the excavation at a 30-degree angle from vertical, as shown on Figure 7. Normally, tieback anchors are contractor-designed and installed, and there are numerous anchor construction methods available.
- 7.5.11 Experience has shown that the use of pressure grouting during formation of the bonded portion of the anchor will increase the soil-grout bond stress. A pressure grouting tube should be installed during the construction of the tieback. Post grouting should be performed if adequate capacity cannot be obtained by other construction methods. Non-shrinkage grout should be used for the construction of the tieback anchors.
- 7.5.12 Anchor capacity is a function of construction method, depth of anchor, batter, diameter of the bonded section, and the length of the bonded section. Table 7.5.1 presents the strength parameters to evaluate anchor capacity.

**TABLE 7.5.1
RECOMMENDED SHEAR STRENGTH PARAMETERS FOR TIEBACK ANCHOR
DESIGN**

Description	Cohesion	Friction Angle
Undocumented Fill	150 psf	28 degrees
Very Old Parallic Deposits and San Diego Formation	400 psf	30 degrees

- 7.5.13 Grout should only be placed in the anchor's bonded section (effective zone) prior to testing or the unbonded section should be covered with PVC pipe. Anchors should be proof tested to at least 130 percent of the anchor's design working load. Following a successful proof test, the anchors should be locked off at approximately 80 percent of the anchor's allowable working load. Anchor test failure criteria should be established in project plans and specifications. Anchor test failure criteria should be based upon a maximum allowable displacement at 130 percent of the anchor's working load (anchor creep) and a maximum residual displacement within the anchor following stressing. Anchor stressing should only be conducted after sufficient hydration has occurred within the anchor grout. Anchors that fail to meet project specified test criteria should be locked off at an appropriate load and additional anchors should be constructed. The shoring engineer should evaluate what the maximum load can be applied to the tieback anchors such that the loads are not exceeded during the testing procedures.
- 7.5.14 Lagging or shotcrete facing should keep pace with excavation and anchor construction. The excavation should not be advanced deeper than three feet below the bottom of lagging at any time. These unlagged gaps of up to three feet should only be allowed to stand for short periods of time in order to decrease the probability of soil sloughing and caving. Backfilling should be conducted when necessary between the back of lagging and excavation sidewalls to reduce sloughing in this zone. Further, the excavation should not be advanced further than four feet below a row of tiebacks prior to those tiebacks being proof tested and locked off.
- 7.5.15 An accurate survey of existing utilities and other underground structures adjacent to the shoring wall should be conducted. The survey should include both locations and depths of existing utilities. Locations of anchors should be adjusted as necessary during the design and construction process so as to accommodate existing and proposed utilities.
- 7.5.16 The condition of existing buildings, streets, sidewalks, and other structures around the perimeter of the planned excavation should be documented prior to the start of shoring and excavation work. Special attention should be given to documenting existing cracks or other indications of differential settlement within these adjacent structures, pavements and other improvements. Any underground utilities sensitive to settlement should be videotaped prior to construction to check the integrity of pipes. In addition, monitoring points should be established indicating location and elevation around the excavation and upon existing buildings. These points should be monitored on a regular basis during construction.
- 7.5.17 Tieback anchors within the City of San Diego right-of-way should be properly detentioned and removed where steel does not exist within the upper 20 feet from the existing grade.

The *Notice – Land Development Review/Shoring in City Right-Of-Way*, prepared by the City of San Diego, dated July 1, 2003 should be reviewed and incorporated into the design of the tieback anchors. Procedures for removal of tieback anchors include unscrewing tendons using special couplings, use of explosives, or heat induction. Geocon Incorporated should be consulted if other methods of removal are planned.

7.6 Soil Nail Wall

- 7.6.1 As an alternative to temporary shoring, a soil nail wall can be used. Soil nail walls consist of installing closely spaced steel bars (nails) into a slope or excavation in a top-down construction sequence. Following installation of a horizontal row of nails drains, waterproofing, and wall reinforcing steel are placed and shotcrete applied to create a final wall.
- 7.6.2 The soil nail wall should be designed by an engineer familiar with the design of soil nail walls.
- 7.6.3 In general, ground conditions are moderately to well suited for soil nail construction techniques. However, gravel, cobble, and cemented zones could be encountered within the existing materials that could be difficult to drill. In addition, relatively clean sand may be encountered within the materials that may result in some raveling of the unsupported excavation.
- 7.6.4 A wall drain system should be incorporated into the design of the soil nail wall. The existing soil should be considered corrosive. Corrosion protection should be provided for the nails if the wall will be a permanent structure.
- 7.6.5 Testing of the soil nails should be performed in accordance with the guidelines of the Federal Highway Administration or similar guidelines. At least two verification tests should be performed to confirm design assumptions for each soil/rock type encountered. Verification tests nails should be sacrificial and should not be used to support the proposed wall. The bond length should be adjusted to allow for pullout testing of the verification nails to evaluate the ultimate bond stress. A minimum of 5 percent of the production nails should also be proof tested. Geocon Incorporated should perform observation of soil nail installation and soil nail testing during the construction operations.
- 7.6.6 In addition to verification and proof testing, at least two pullout tests should be performed at the discretion of the soil engineer to check the geotechnical design parameters. During testing, the nail should be loaded incrementally until failure of the soil-grout bond or until

the stress imposed on the nail reaches 80 percent of the bar yield strength. The bonded length should be confirmed prior to testing.

7.6.7 Table 7.6.1 presents the soil strength parameters to incorporate in the design of the soil nail walls.

**TABLE 7.6.1
SOIL STRENGTH PARAMETERS FOR SOIL NAIL WALLS**

Description	Cohesion	Friction Angle	Ultimate Bond Stress
Undocumented Fill	150 psf	28 degrees	10 psi
Very Old Paralic Deposits and San Diego Formation	350 psf	30 degrees	20 psi

7.7 Conventional Shallow Foundations

7.7.1 The proposed structure can be supported on a conventional shallow foundation system bearing on Very Old Paralic Deposits or the San Diego Formation. Foundations for the structures should consist of continuous strip footings and/or isolated spread footings. Continuous footings should be at least 12 inches wide and extend at least 24 inches below lowest adjacent pad grade. Isolated spread footings should have a minimum width of 24 inches and depth of 24 inches.

7.7.2 Steel reinforcement for continuous footings should consist of at least four No. 5 steel reinforcing bars placed horizontally in the footings; two near the top and two near the bottom. Steel reinforcement for the spread footings should be designed by the project structural engineer. A wall/column footing dimension detail is presented on Figure 8.

7.7.3 The minimum reinforcement recommended herein is based on soil characteristics only (EI of 50 or less) and is not intended to replace reinforcement required for structural considerations.

7.7.4 The recommended allowable bearing capacity for foundations with minimum dimensions described herein is 9,000 psf for footings bearing in the Very Old Paralic Deposits or the San Diego Formation. The allowable soil bearing pressure may be increased by an additional 500 psf for each additional foot of depth and 300 psf for each additional foot of width, to a maximum allowable bearing capacity of 13,000 psf for footings bearing in formational materials. The values presented herein are for dead plus live loads and may be increased by one-third when considering transient loads due to wind or seismic forces. These values are based on an excavation depth of 40 feet.

- 7.7.5 We estimate the total and differential settlements under the imposed allowable loads are estimated to be ½ inch using an 8-foot square foundation. We estimate the total and differential settlements under the imposed allowable loads are estimated to be 1 inch using a 14-foot-square foundation. We should be contacted to provide additional settlement calculations for larger foundations.
- 7.7.6 Where buildings or other improvements are planned near the top of a slope steeper than 3:1 (horizontal to vertical), special foundations and/or design considerations are recommended due to the tendency for lateral soil movement to occur. Building and retaining wall footings should be deepened such that the bottom outside edge of the footing is at least 7 feet horizontally from the face of the slope.
- 7.7.7 Foundation excavations should be observed by the geotechnical engineer (a representative of Geocon Incorporated) prior to the placement of reinforcing steel to check that the exposed soil conditions are similar to those expected and that they have been extended to the appropriate bearing strata. Foundation modifications may be required if unexpected soil conditions are encountered.
- 7.7.8 The San Diego Formation consists of sandy material. Typically, foundation excavations within the sandy portion of the San Diego Formation dry relatively quickly and the material deposits into the bottom of the footing excavations. Forming of the foundations or temporary slopes with extra concrete being placed may be required.

7.8 Concrete Slabs-on-Grade

- 7.8.1 Interior concrete slabs-on-grade for the parking structure should be at least 5 inches thick. As a minimum, reinforcement for slabs-on-grade should consist of No. 4 reinforcing bars placed at 18 inches on center in both horizontal directions.
- 7.8.2 The concrete slab-on-grade recommendations are based on soil support characteristics only. The project structural engineer should evaluate the structural requirements of the concrete slabs for supporting equipment and storage loads.
- 7.8.3 Slabs that may receive moisture-sensitive floor coverings or may be used to store moisture-sensitive materials should be underlain by a vapor retarder. The vapor retarder design should be consistent with the guidelines presented in the American Concrete Institute's (ACI) *Guide for Concrete Slabs that Receive Moisture-Sensitive Flooring Materials* (ACI 302.2R-06). The vapor retarder used should be specified by the project architect or

developer based on the type of floor covering that will be installed and if the structure will possess a humidity controlled environment.

- 7.8.4 The bedding sand thickness should be determined by the project foundation engineer, architect, and/or developer. However, we should be contacted to provide recommendations if the bedding sand is thicker than 6 inches. It is common to see 3 inches of sand below the concrete slab-on-grade for 5-inch-thick slabs in the southern California area. The foundation design engineer should provide appropriate concrete mix design criteria and curing measures to assure proper curing of the slab by reducing the potential for rapid moisture loss and subsequent cracking and/or slab curl. We suggest that the foundation design engineer present the concrete mix design and proper curing methods on the foundation plans. It is critical that the foundation contractor understands and follows the recommendations presented on the foundation plans.
- 7.8.5 To control the location and spread of concrete shrinkage cracks, crack control joints should be provided. The crack control joints should be created while the concrete is still fresh using a grooving tool, or shortly thereafter using saw cuts. The structural engineer should take into consideration criteria of the American Concrete Institute when establishing crack control spacing patterns.
- 7.8.6 Special subgrade presaturation is not deemed necessary prior to placing concrete; however, the exposed foundation and slab subgrade soil should be moisturized to maintain a moist condition as would be expected in any such concrete placement.
- 7.8.7 Where exterior flatwork abuts the structure at entrant or exit areas, the exterior slab should be dowelled into the structure's foundation stemwall. This recommendation is intended to reduce the potential for differential elevations that could result from differential settlement or minor heave of the flatwork. Dowelling details should be designed by the project structural engineer.
- 7.8.8 Geocon Incorporated should be consulted to provide additional design parameters as required by the structural engineer.

7.9 Concrete Flatwork

- 7.9.1 Exterior concrete flatwork not subject to vehicular traffic should be constructed in accordance with the recommendations herein. Slab panels should be a minimum of 4 inches thick and, when in excess of 8 feet square, should be reinforced with 6 x 6 - W2.9/W2.9 (6 x 6 - 6/6) welded wire mesh or No. 3 reinforcing bars at 18 inches

on center in both directions to reduce the potential for cracking. In addition, concrete flatwork should be provided with crack control joints to reduce and/or control shrinkage cracking. Crack control spacing should be determined by the project structural engineer based upon the slab thickness and intended usage. Criteria of the American Concrete Institute (ACI) should be taken into consideration when establishing crack control spacing. Subgrade soil for exterior slabs not subjected to vehicle loads should be compacted in accordance with criteria presented in the grading section prior to concrete placement. Subgrade soil should be properly compacted and the moisture content of subgrade soil should be checked prior to placing concrete.

7.9.2 Even with the incorporation of the recommendations within this report, the exterior concrete flatwork has a likelihood of experiencing some uplift due to potentially expansive soil beneath grade; therefore, the steel reinforcement should overlap continuously in flatwork to reduce the potential for vertical offsets within flatwork. Additionally, flatwork should be structurally connected to the curbs, where possible, to reduce the potential for offsets between the curbs and the flatwork.

7.9.3 Where exterior flatwork abuts the structure at entrant or exit points, the exterior slab should be dowelled into the structure's foundation stemwall. This recommendation is intended to reduce the potential for differential elevations that could result from differential settlement or minor heave of the flatwork. Dowelling details should be designed by the project structural engineer.

7.9.4 The recommendations presented herein are intended to reduce the potential for cracking of slabs and foundations as a result of differential movement. However, even with the incorporation of the recommendations presented herein, foundations and slabs-on-grade will still crack. The occurrence of concrete shrinkage cracks is independent of the soil supporting characteristics. Their occurrence may be reduced and/or controlled by limiting the slump of the concrete, the use of crack control joints and proper concrete placement and curing. Literature provided by the Portland Concrete Association (PCA) and American Concrete Institute (ACI) present recommendations for proper concrete mix, construction, and curing practices, and should be incorporated into project construction.

7.10 Preliminary Rigid Pavement Recommendations

7.10.1 We understand the alleyway may be removed and replaced during the construction operations. A rigid Portland Cement concrete (PCC) pavement section should be placed in driveway entrance aprons areas. We calculated the rigid pavement section in general conformance with the procedure recommended by the American Concrete Institute report

ACI 330R-08 Guide for Design and Construction of Concrete Parking Lots using the parameters presented in Table 7.10.1.

**TABLE 7.10.1
RIGID PAVEMENT DESIGN PARAMETERS**

Design Parameter	Design Value
Modulus of subgrade reaction, k	100 pci
Modulus of rupture for concrete, M_R	500 psi
Traffic Category, TC	C
Average daily truck traffic, ADTT	100

7.10.2 Based on the criteria presented herein, the PCC pavement sections should have a minimum thickness as presented in Table 7.10.2.

**TABLE 7.10.2
RIGID PAVEMENT RECOMMENDATIONS**

Location	Portland Cement Concrete (inches)
Driveway entrances and Aprons (TC=C)	7.0

7.10.3 The PCC pavement should be placed over subgrade soil that is compacted to a dry density of at least 95 percent of the laboratory maximum dry density near to slightly above optimum moisture content. This pavement section is based on a minimum concrete compressive strength of approximately 3,000 psi (pounds per square inch).

7.10.4 A thickened edge or integral curb should be constructed on the outside of concrete slabs subjected to wheel loads. The thickened edge should be 1.2 times the slab thickness or a minimum thickness of 2 inches, whichever results in a thicker edge, and taper back to the recommended slab thickness 4 feet behind the face of the slab (e.g., a 7-inch-thick slab would have a 9-inch-thick edge). Reinforcing steel will not be necessary within the concrete for geotechnical purposes with the possible exception of dowels at construction joints as discussed herein.

7.10.5 To control the location and spread of concrete shrinkage cracks, crack-control joints (weakened plane joints) should be included in the design of the concrete pavement slab. Crack-control joints should not exceed 30 times the slab thickness with a maximum spacing of 15 feet for the 7-inch-thick slabs and should be sealed with an appropriate sealant to prevent the migration of water through the control joint to the subgrade

materials. The depth of the crack-control joints should be determined by the referenced ACI report.

7.10.6 To provide load transfer between adjacent pavement slab sections, a butt-type construction joint should be constructed. The butt-type joint should be thickened by at least 20 percent at the edge and taper back at least 4 feet from the face of the slab. As an alternative to the butt-type construction joint, dowelling can be used between construction joints for pavements of 7 inches or thicker. As discussed in the referenced ACI guide, dowels should consist of smooth, 1-inch-diameter reinforcing steel 14 inches long embedded a minimum of 6 inches into the slab on either side of the construction joint. Dowels should be located at the midpoint of the slab, spaced at 12 inches on center and lubricated to allow joint movement while still transferring loads. In addition, tie bars should be installed as recommended in Section 3.8.3 of the referenced ACI guide. The structural engineer should provide other alternative recommendations for load transfer.

7.10.7 We should be contacted to provide additional pavement recommendations, if required.

7.11 Retaining Walls

7.11.1 Retaining walls not restrained at the top and having a level backfill surface should be designed for an active soil pressure equivalent to the pressure exerted by a fluid density of 35 pounds per cubic foot (pcf). Where the backfill will be inclined at 2:1 (horizontal to vertical), an active soil pressure of 50 pcf is recommended. Soil with an expansion index (EI) of greater than 50 should not be used as backfill material behind retaining walls.

7.11.2 Unrestrained walls are those that are allowed to rotate more than $0.001H$ (where H equals the height of the retaining portion of the wall) at the top of the wall. Where walls are restrained from movement at the top, an additional uniform pressure of $7H$ psf should be added to the active soil pressure for walls 10 feet high or less. The active pressure should be increased to $13H$ for the portion of the walls higher than 10 feet. For retaining walls subject to vehicular loads within a horizontal distance equal to two-thirds the wall height, a surcharge equivalent to 2 feet of fill soil should be added. Loads from the adjacent housing structures should be incorporated into the design of the subterranean garage retaining wall, if applicable.

7.11.3 The use of drainage openings through the base of the wall (weep holes) is not recommended where the seepage could be a nuisance or otherwise adversely affect the property adjacent to the base of the wall. The recommendations herein assume a properly compacted granular (EI of 50 or less) free-draining backfill material with no hydrostatic forces or imposed surcharge load. Figure 9 presents a typical retaining wall drain detail.

Figure 10 presents a soldier pile wall drainage details. If conditions different than those described are expected, or if specific drainage details are desired, Geocon Incorporated should be contacted for additional recommendations.

- 7.11.4 The structural engineer should determine the seismic design category for the project. If the project possesses a seismic design category of D, E, or F, the proposed retaining walls should be designed with seismic lateral pressure. A seismic load of $19H$ should be used for design on walls that support more than 6 feet of backfill in accordance with Section 1803.5.12 of the 2013 CBC. The seismic load is dependent on the retained height where H is the height of the wall, in feet, and the calculated loads result in pounds per square foot (psf) exerted at the base of the wall and zero at the top of the wall. We used the peak site acceleration, PGA_M , of 0.508g calculated from ASCE 7-10 Section 11.8.3 and applied a pseudo-static coefficient of 0.3.
- 7.11.5 The recommendations presented herein are generally applicable to the design of rigid concrete or masonry retaining walls having a maximum height of 15 feet. In the event that walls higher than 15 feet or other types of walls (such as crib-type walls) are planned, Geocon Incorporated should be consulted for additional recommendations.
- 7.11.6 Unrestrained walls will move laterally when backfilled and loading is applied. The amount of lateral deflection is dependent on the wall height, the type of soil used for backfill, and loads acting on the wall. The retaining walls and improvements above the retaining walls should be designed to incorporate an appropriate amount of lateral deflection as determined by the structural engineer.

7.12 Lateral Loading

- 7.12.1 To resist lateral loads, a passive pressure exerted by an equivalent fluid weight of 350 pounds per cubic foot (pcf) should be used for the design of footings or shear keys poured neat in compacted fill. The passive pressure assumes a horizontal surface extending at least 5 feet, or three times the surface generating the passive pressure, whichever is greater. The upper 12 inches of material in areas not protected by floor slabs or pavement should not be included in design for passive resistance.
- 7.12.2 If friction is to be used to resist lateral loads, an allowable coefficient of friction between soil and concrete of 0.4 should be used for design.

7.13 Site Drainage and Moisture Protection

- 7.13.1 Adequate site drainage is critical to reduce the potential for differential soil movement, erosion and subsurface seepage. Under no circumstances should water be allowed to pond adjacent to footings and improvements. The site should be graded and maintained such that surface drainage is directed away from structures in accordance with 2013 CBC 1804.3 or other applicable standards. In addition, surface drainage should be directed away from the top of slopes into swales or other controlled drainage devices. Roof and pavement drainage should be directed into conduits that carry runoff away from the proposed structure.
- 7.13.2 In the case of basement walls or building walls retaining landscaping areas, a waterproofing system should be used on the wall and joints, and a Miradrain drainage panel (or similar) should be placed over the waterproofing. A perforated drainpipe of schedule 40 or better should be installed at the base of the wall below the floor slab and drained to an appropriate discharge area. Accordion-type pipe is not acceptable. The project architect or civil engineer should provide detailed specifications on the plans for all waterproofing and drainage.
- 7.13.3 Underground utilities should be leak free. Utility and irrigation lines should be checked periodically for leaks, and detected leaks should be repaired promptly. Detrimental soil movement could occur if water is allowed to infiltrate the soil for prolonged periods of time.
- 7.13.4 Landscaping planters adjacent to paved areas are not recommended due to the potential for surface or irrigation water to infiltrate the pavement's subgrade and base course. We recommend that area drains to collect excess irrigation water and transmit it to drainage structures or impervious above-grade planter boxes be used. In addition, where landscaping is planned adjacent to the pavement, we recommend construction of a cutoff wall along the edge of the pavement that extends at least 6 inches below the bottom of the base materials.
- 7.13.5 If detention basins, bioswales, retention basins, water infiltration, low impact development (LID), or storm water management devices are being considered, Geocon Incorporated should be retained to provide recommendations pertaining to the geotechnical aspects of possible impacts and design.
- 7.13.6 If not properly constructed, there is a potential for distress to improvements and properties located hydrologically down gradient or adjacent to these devices. Factors such as the amount of water to be detained, its residence time, and soil permeability have an important effect on seepage transmission and the potential adverse impacts that may occur if the storm water management features are not properly designed and constructed. We have not

performed a hydrogeology study at the site. Down-gradient and adjacent structures may be subjected to seeps, movement of foundations and slabs, or other impacts as a result of water infiltration if incorporated into the storm water management devices.

- 7.13.7 Storm water management devices should be properly constructed to prevent water infiltration and lined with an impermeable liner (e.g. High-density polyethylene, HDPE, with a thickness of about 30 mil or equivalent Polyvinyl Chloride, PVC, liner). The devices should also be installed in accordance with the manufacturer's recommendations.

7.14 Grading and Foundation Plan Review

- 7.14.1 Geocon Incorporated should review the final grading and foundation plans prior to finalization to check their compliance with the recommendations of this report and evaluate the need for additional comments, recommendations, and/or analyses.

LIMITATIONS AND UNIFORMITY OF CONDITIONS

1. The firm that performed the geotechnical investigation for the project should be retained to provide testing and observation services during construction to provide continuity of geotechnical interpretation and to check that the recommendations presented for geotechnical aspects of site development are incorporated during site grading, construction of improvements, and excavation of foundations. If another geotechnical firm is selected to perform the testing and observation services during construction operations, that firm should prepare a letter indicating their intent to assume the responsibilities of project geotechnical engineer of record. A copy of the letter should be provided to the regulatory agency for their records. In addition, that firm should provide revised recommendations concerning the geotechnical aspects of the proposed development, or a written acknowledgement of their concurrence with the recommendations presented in our report. They should also perform additional analyses deemed necessary to assume the role of Geotechnical Engineer of Record.
2. The recommendations of this report pertain only to the site investigated and are based upon the assumption that the soil conditions do not deviate from those disclosed in the investigation. If any variations or undesirable conditions are encountered during construction, or if the proposed construction will differ from that anticipated herein, Geocon Incorporated should be notified so that supplemental recommendations can be given. The evaluation or identification of the potential presence of hazardous or corrosive materials was not part of the scope of services provided by Geocon Incorporated.
3. This report is issued with the understanding that it is the responsibility of the owner or his representative to ensure that the information and recommendations contained herein are brought to the attention of the architect and engineer for the project and incorporated into the plans, and the necessary steps are taken to see that the contractor and subcontractors carry out such recommendations in the field.
4. The findings of this report are valid as of the present date. However, changes in the conditions of a property can occur with the passage of time, whether they be due to natural processes or the works of man on this or adjacent properties. In addition, changes in applicable or appropriate standards may occur, whether they result from legislation or the broadening of knowledge. Accordingly, the findings of this report may be invalidated wholly or partially by changes outside our control. Therefore, this report is subject to review and should not be relied upon after a period of three years.

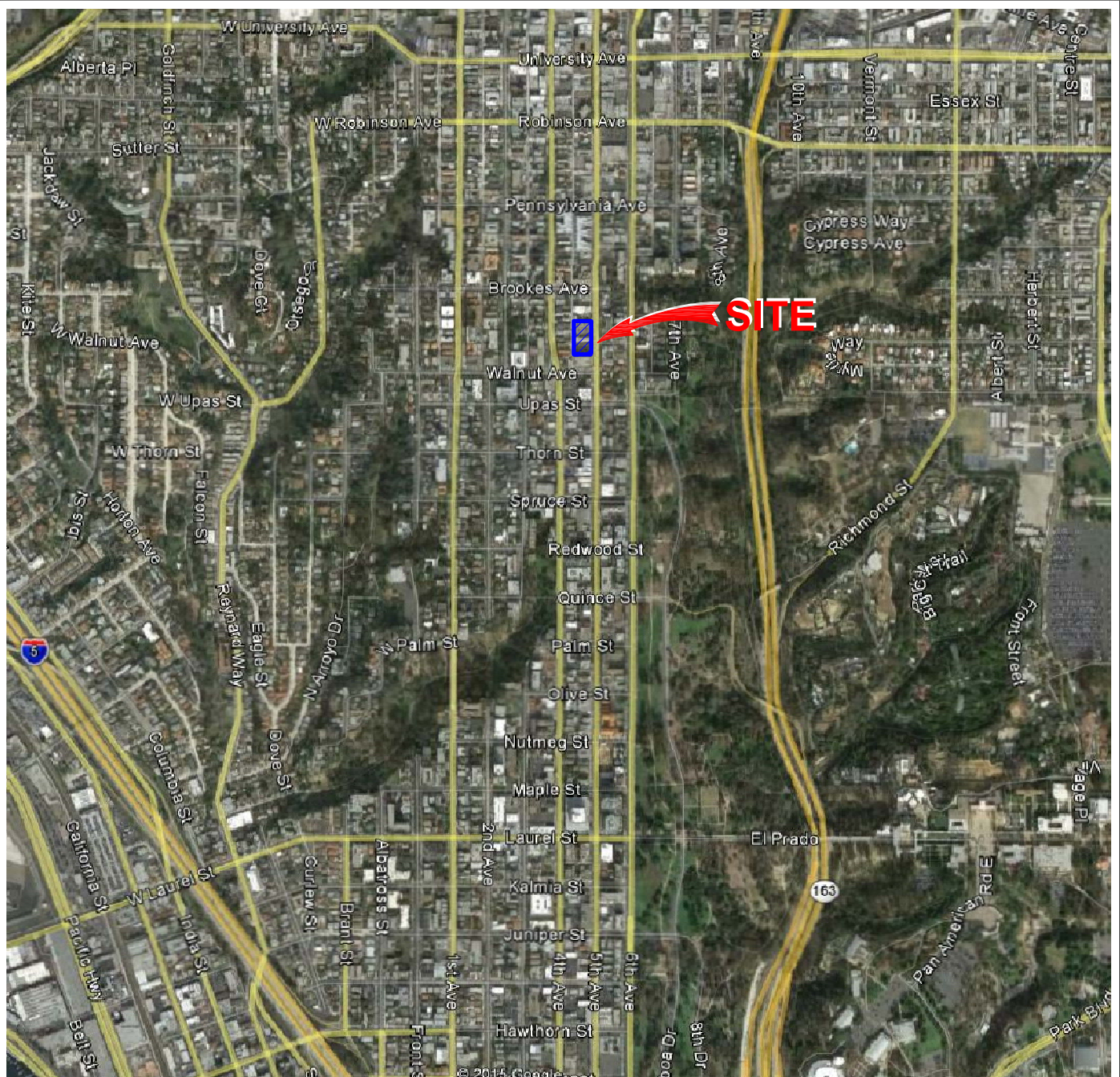

THE GEOGRAPHICAL INFORMATION MADE AVAILABLE FOR DISPLAY WAS PROVIDED BY GOOGLE EARTH, SUBJECT TO A LICENSING AGREEMENT. THE INFORMATION IS FOR ILLUSTRATIVE PURPOSES ONLY; IT IS NOT INTENDED FOR CLIENT'S USE OR RELIANCE AND SHALL NOT BE REPRODUCED BY CLIENT. CLIENT SHALL INDEMNIFY, DEFEND AND HOLD HARMLESS GEOCON FROM ANY LIABILITY INCURRED AS A RESULT OF SUCH USE OR RELIANCE BY CLIENT.



NO SCALE

VICINITY MAP

GEOCON
INCORPORATED



GEOTECHNICAL ■ ENVIRONMENTAL ■ MATERIALS
6960 FLANDERS DRIVE - SAN DIEGO, CALIFORNIA 92121 - 2974
PHONE 858 558-6900 - FAX 858 558-6159

STRAUSS FIFTH AVENUE APARTMENTS
SAN DIEGO, CALIFORNIA

AG / AML	DSK/GTYPD	DATE 05 - 08 - 2015	PROJECT NO. G1815 - 11 - 01	FIG. 1
----------	-----------	---------------------	-----------------------------	--------

STRAUSS FIFTH AVENUE APARTMENTS
SAN DIEGO, CALIFORNIA

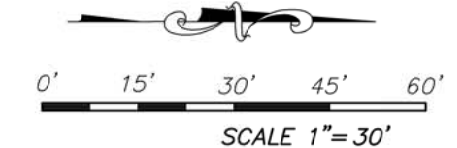
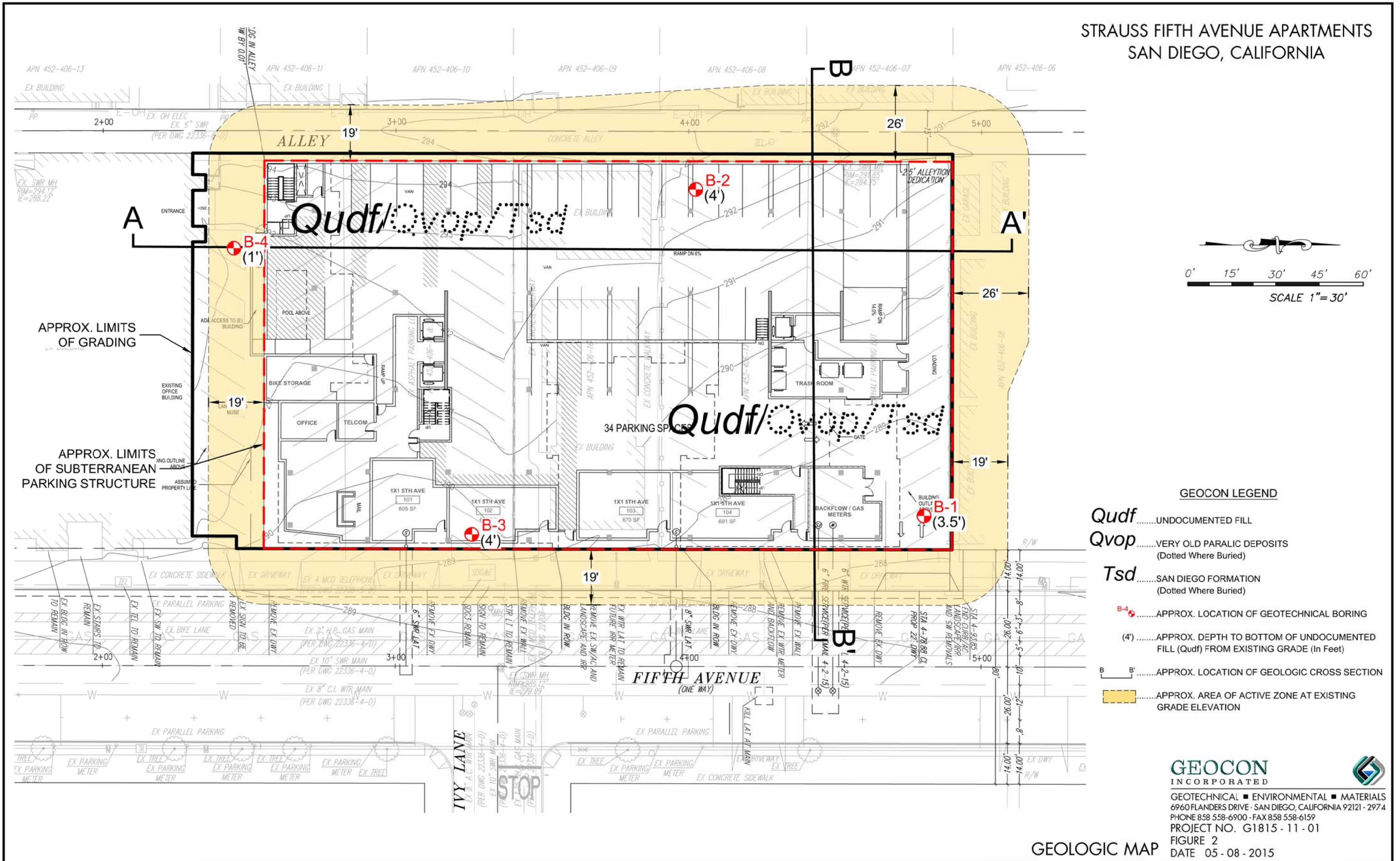

- GEOCON LEGEND**
- Qudf** UNDOCUMENTED FILL
 - Qvop** VERY OLD PARALIC DEPOSITS
(Dotted Where Buried)
 - Tsd** SAN DIEGO FORMATION
(Dotted Where Buried)
 - B-4** APPROX. LOCATION OF GEOTECHNICAL BORING
 - (4')** APPROX. DEPTH TO BOTTOM OF UNDOCUMENTED FILL (Qudf) FROM EXISTING GRADE (In Feet)
 - B** APPROX. LOCATION OF GEOLOGIC CROSS SECTION
 - [Yellow Area]** APPROX. AREA OF ACTIVE ZONE AT EXISTING GRADE ELEVATION

GEOCON
INCORPORATED

GEOTECHNICAL ■ ENVIRONMENTAL ■ MATERIALS
6960 FLANDERS DRIVE · SAN DIEGO, CALIFORNIA 92121 · 297.4
PHONE 858 558-6900 · FAX 858 558-6159
PROJECT NO. G1815-11-01
FIGURE 2
DATE 05-08-2015

GEOLOGIC MAP

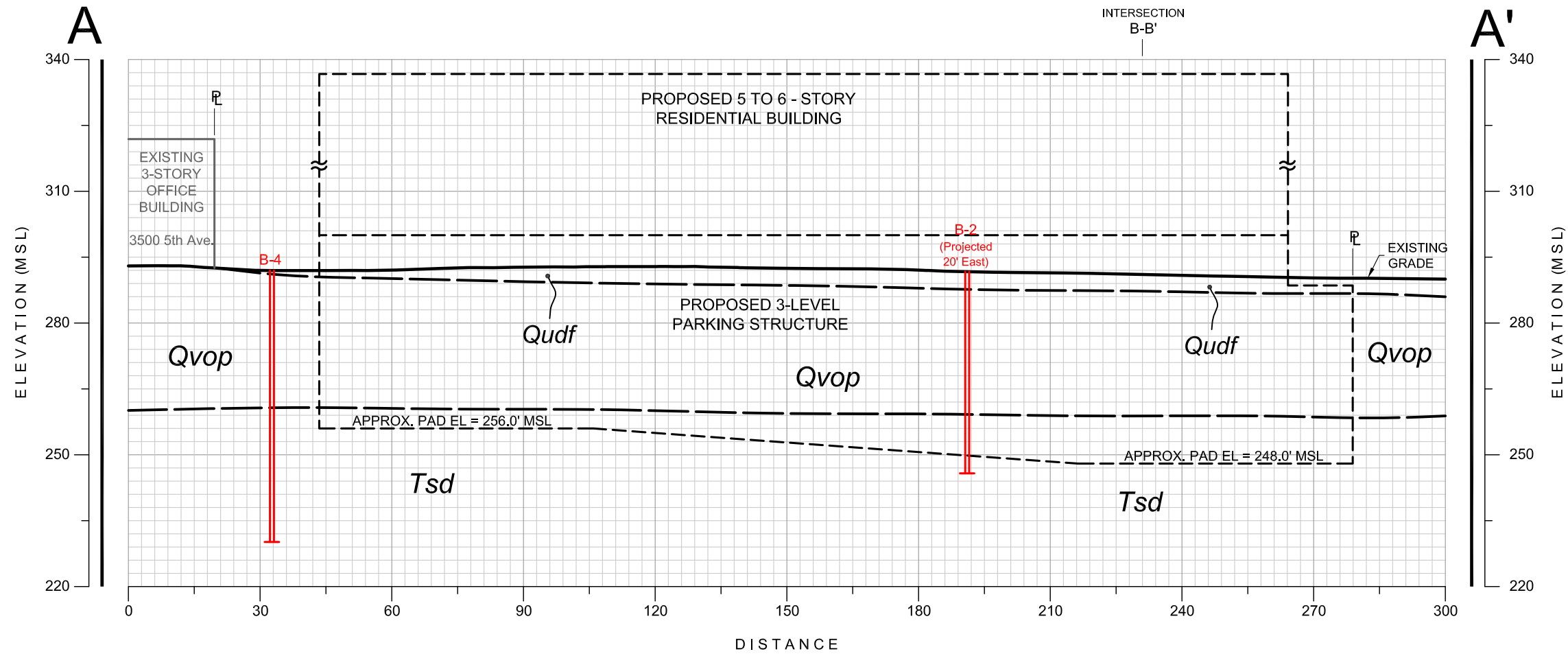

GEOLOGIC CROSS-SECTION A-A'

SCALE: 1" = 30' (Vert. = Horiz.)

GEOCON LEGEND

- Qudf* UNDOCUMENTED FILL
- Qvop* VERY OLD PARALIC DEPOSITS
- Tsd* SAN DIEGO FORMATION
- ~ APPROX. LOCATION OF GEOLOGIC CONTACT
- B-4
|| APPROX. LOCATION OF BORING

GEOCON
INCORPORATED

GEOTECHNICAL ■ ENVIRONMENTAL ■ MATERIALS
6960 FLANDERS DRIVE - SAN DIEGO, CALIFORNIA 92121 - 2974
PHONE 858 558-6900 - FAX 858 558-6159
PROJECT NO. G1815-11-01
FIGURE 3
DATE 05-08-2015

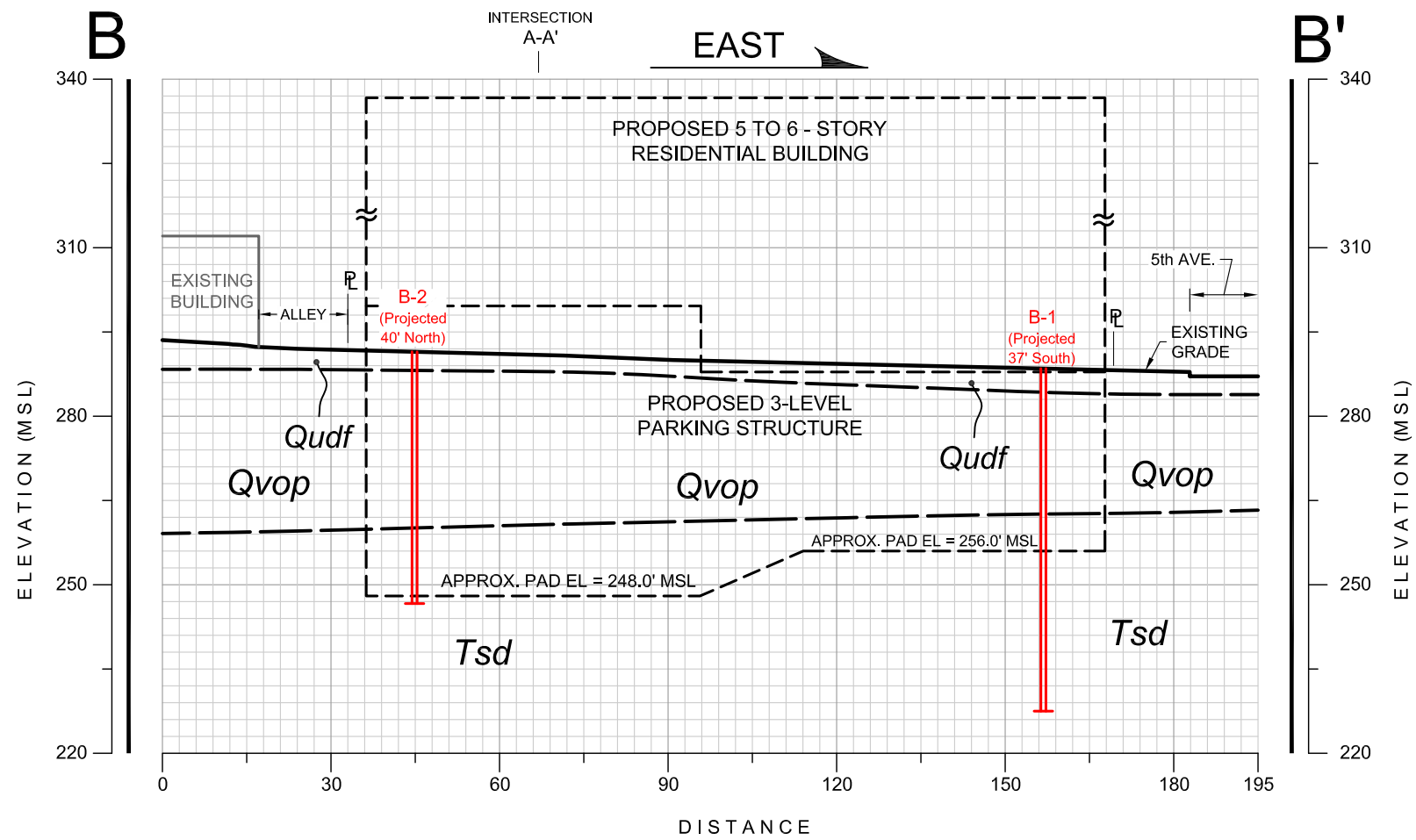

GEOLOGIC CROSS-SECTION B-B'

SCALE: 1" = 30' (Vert. = Horiz.)

GEOCON LEGEND

- Qudf*UNDOCUMENTED FILL
- Qvop*VERY OLD PARALIC DEPOSITS
- Tsd*SAN DIEGO FORMATION
- ~APPROX. LOCATION OF GEOLOGIC CONTACT
- B-2APPROX. LOCATION OF BORING

GEOCON
INCORPORATED

GEOTECHNICAL ■ ENVIRONMENTAL ■ MATERIALS
6960 FLANDERS DRIVE - SAN DIEGO, CALIFORNIA 92121 - 2974
PHONE 858 558-6900 - FAX 858 558-6159
PROJECT NO. G1815-11-01
FIGURE 4
DATE 05-08-2015

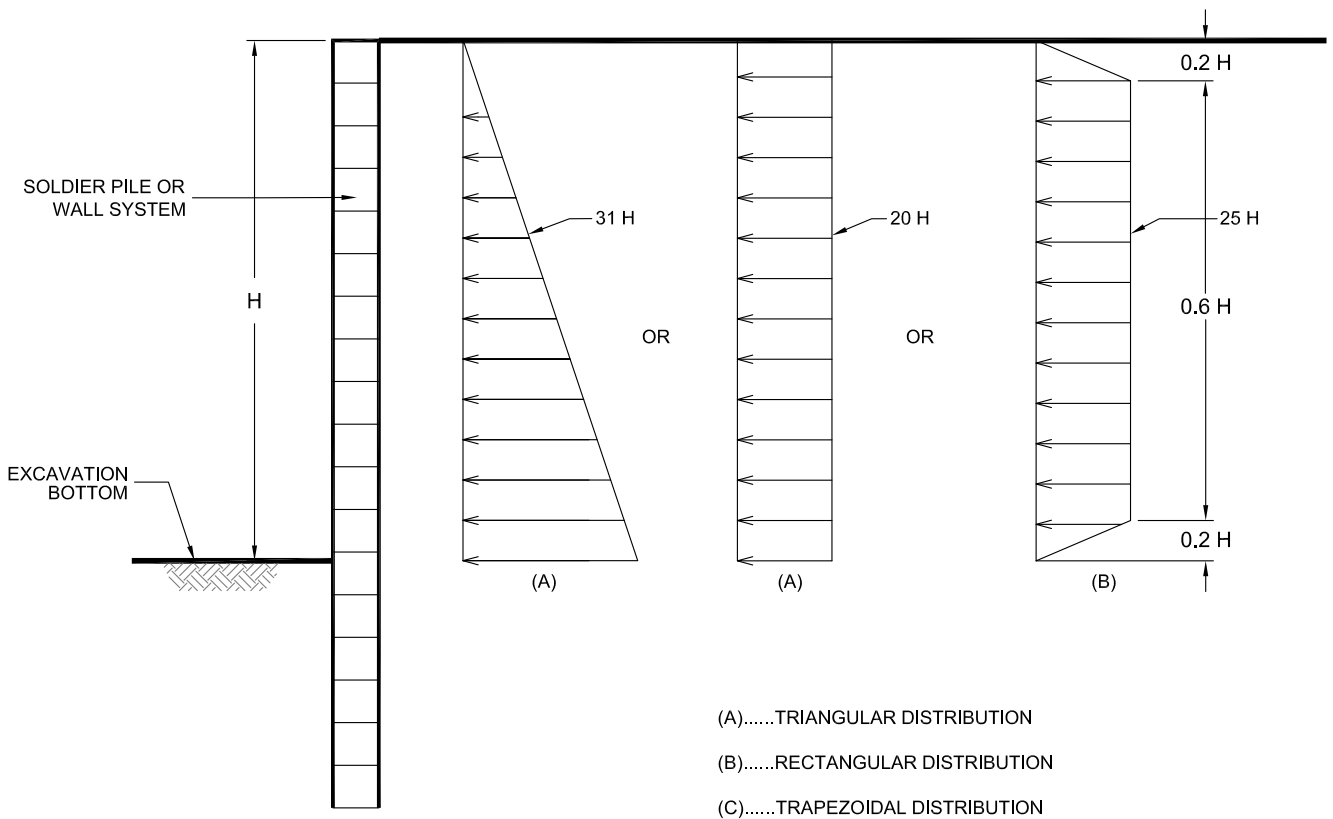

NO SCALE

LATERAL ACTIVE PRESSURES FOR VERTICAL EXCAVATIONS

GEOCON
INCORPORATED



GEOTECHNICAL ■ ENVIRONMENTAL ■ MATERIALS
 6960 FLANDERS DRIVE - SAN DIEGO, CALIFORNIA 92121 - 2974
 PHONE 858 558-6900 - FAX 858 558-6159

STRAUSS FIFTH AVENUE APARTMENTS
 SAN DIEGO, CALIFORNIA

AG / AML

DSK/GTYPD

DATE 05 - 08 - 2015

PROJECT NO. G1815 - 11 - 01

FIG. 5

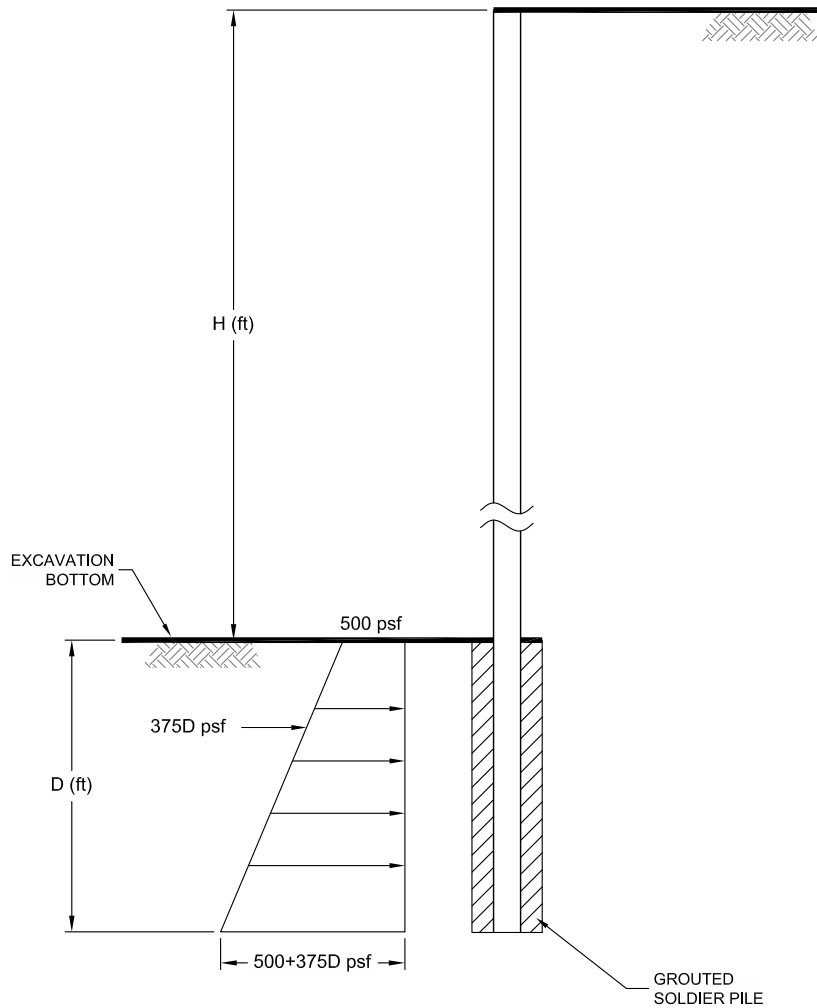

NO SCALE

RECOMMENDED GROUTED SOLDIER PILE PRESSURE DISTRIBUTION

GEOCON
INCORPORATED



GEOTECHNICAL ■ ENVIRONMENTAL ■ MATERIALS
6960 FLANDERS DRIVE - SAN DIEGO, CALIFORNIA 92121 - 2974
PHONE 858 558-6900 - FAX 858 558-6159

STRAUSS FIFTH AVENUE APARTMENTS
SAN DIEGO, CALIFORNIA

AG / AML

DSK/GTYPD

DATE 05 - 08 - 2015

PROJECT NO. G1815 - 11 - 01

FIG. 6

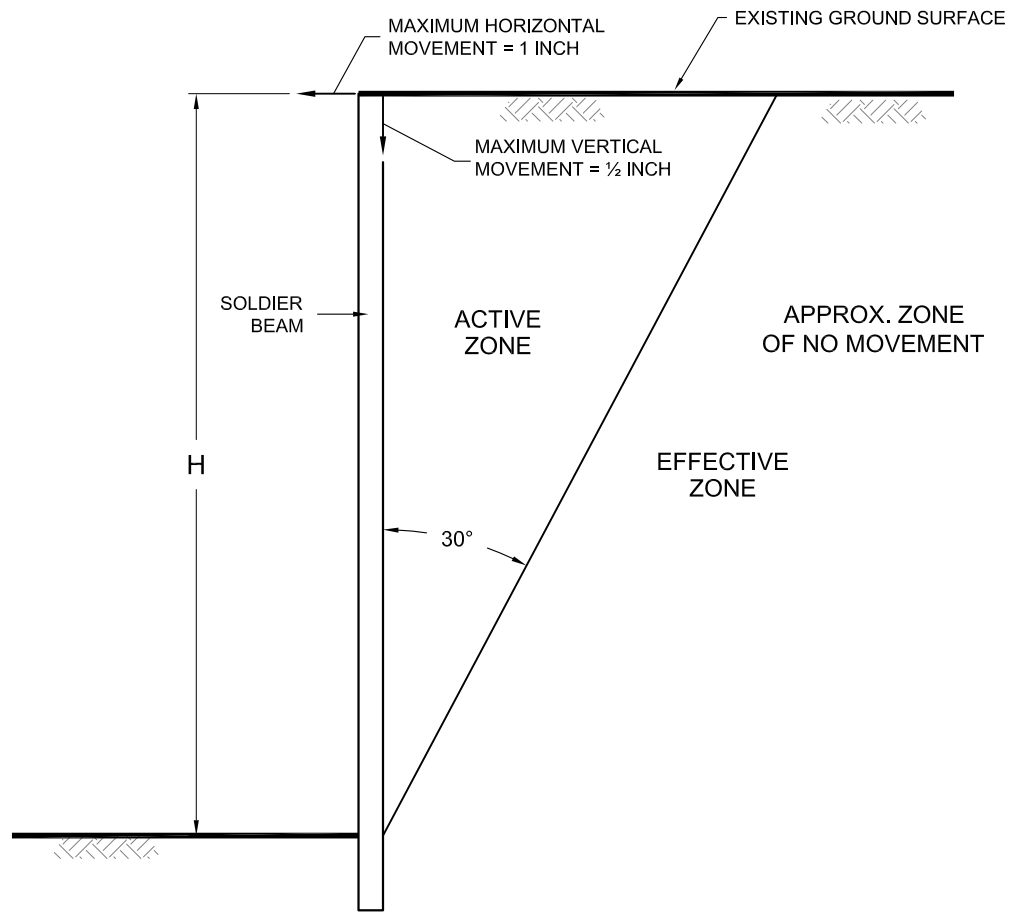

NO SCALE

RECOMMENDED EFFECTIVE ZONE FOR TIEBACK ANCHORS

GEOCON
INCORPORATED



GEOTECHNICAL ■ ENVIRONMENTAL ■ MATERIALS
6960 FLANDERS DRIVE - SAN DIEGO, CALIFORNIA 92121 - 2974
PHONE 858 558-6900 - FAX 858 558-6159

STRAUSS FIFTH AVENUE APARTMENTS
SAN DIEGO, CALIFORNIA

AG / AML

DSK/GTYPD

DATE 05 - 08 - 2015

PROJECT NO. G1815 - 11 - 01

FIG. 7

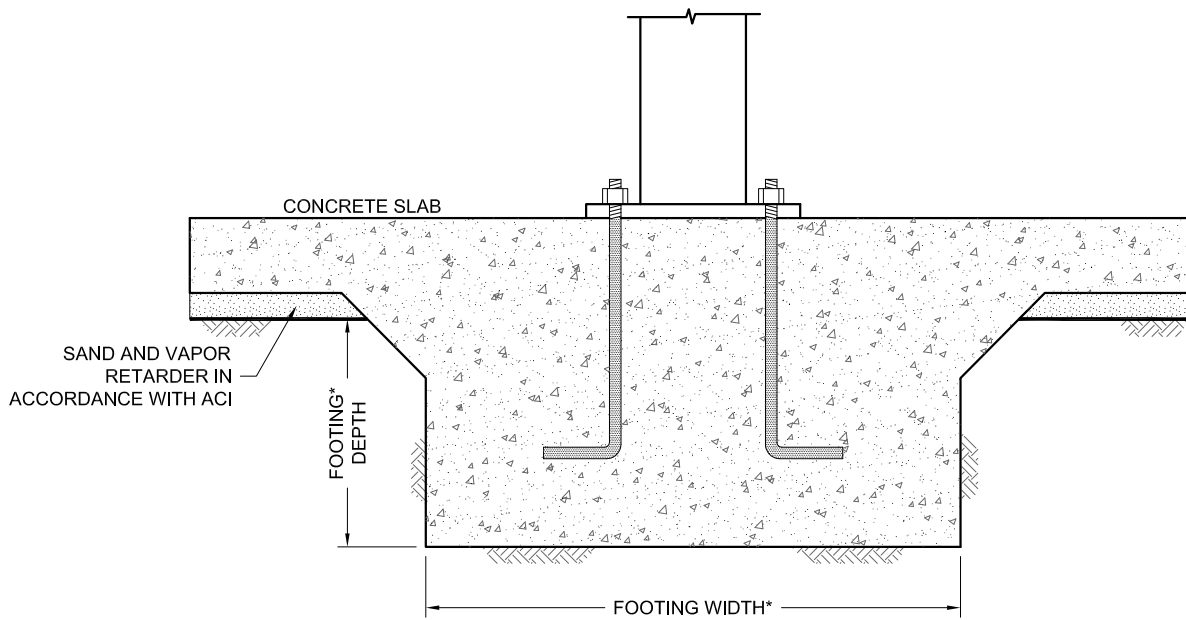
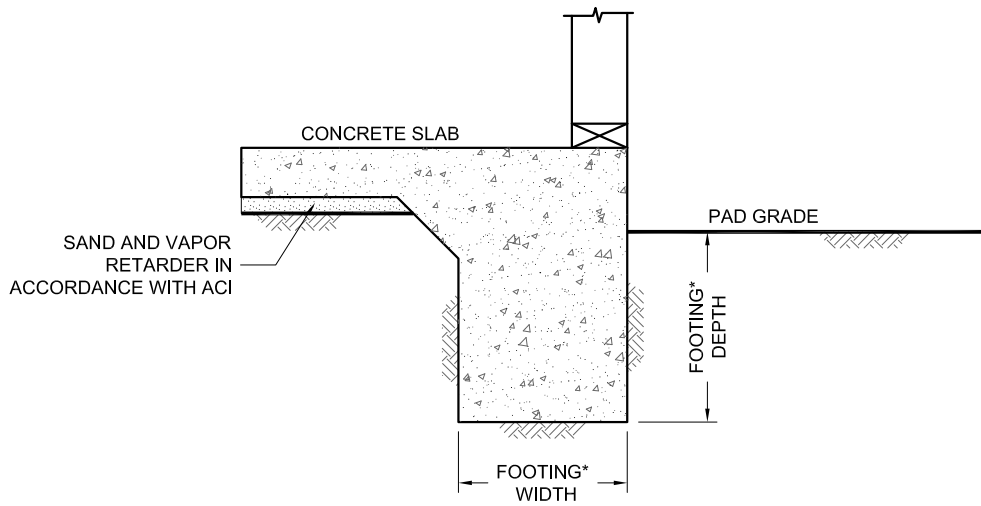

* ...SEE REPORT FOR FOUNDATION WIDTH AND DEPTH RECOMMENDATION

NO SCALE

WALL / COLUMN FOOTING DIMENSION DETAIL

GEOCON
INCORPORATED



GEOTECHNICAL ■ ENVIRONMENTAL ■ MATERIALS
6960 FLANDERS DRIVE - SAN DIEGO, CALIFORNIA 92121 - 2974
PHONE 858 558-6900 - FAX 858 558-6159

STRAUSS FIFTH AVENUE APARTMENTS
SAN DIEGO, CALIFORNIA

AG / AML

DSK/GTYPD

DATE 05 - 08 - 2015

PROJECT NO. G1815 - 11 - 01

FIG. 8

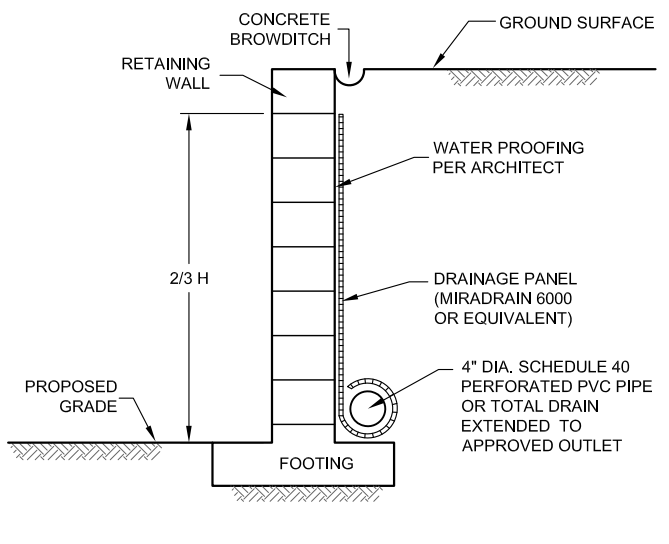
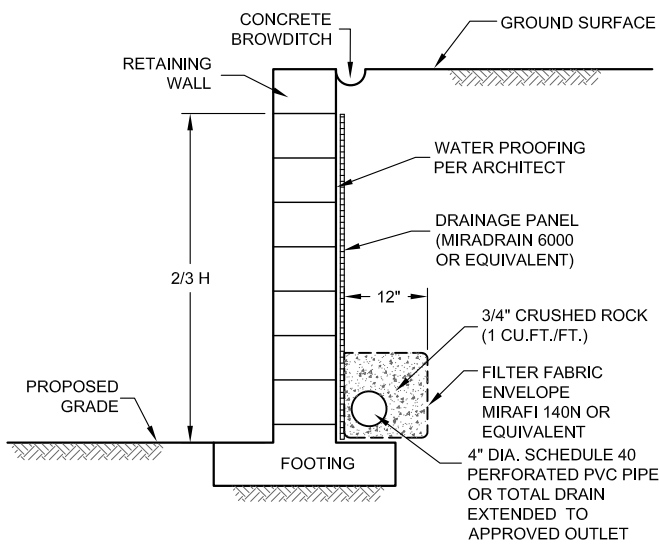
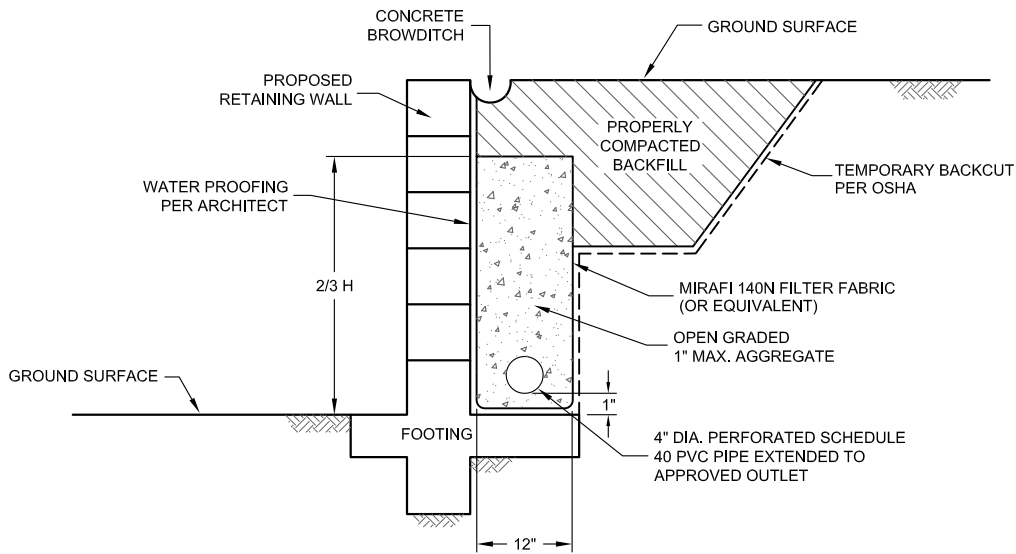

NOTE :

DRAIN SHOULD BE UNIFORMLY SLOPED TO GRAVITY OUTLET OR TO A SUMP WHERE WATER CAN BE REMOVED BY PUMPING

NO SCALE

TYPICAL RETAINING WALL DRAIN DETAIL

GEOCON
INCORPORATED



GEOTECHNICAL ■ ENVIRONMENTAL ■ MATERIALS
6960 FLANDERS DRIVE - SAN DIEGO, CALIFORNIA 92121 - 2974
PHONE 858 558-6900 - FAX 858 558-6159

STRAUSS FIFTH AVENUE APARTMENTS
SAN DIEGO, CALIFORNIA

AG / AML

DSK/GTYPD

DATE 05 - 08 - 2015

PROJECT NO. G1815 - 11 - 01

FIG. 9

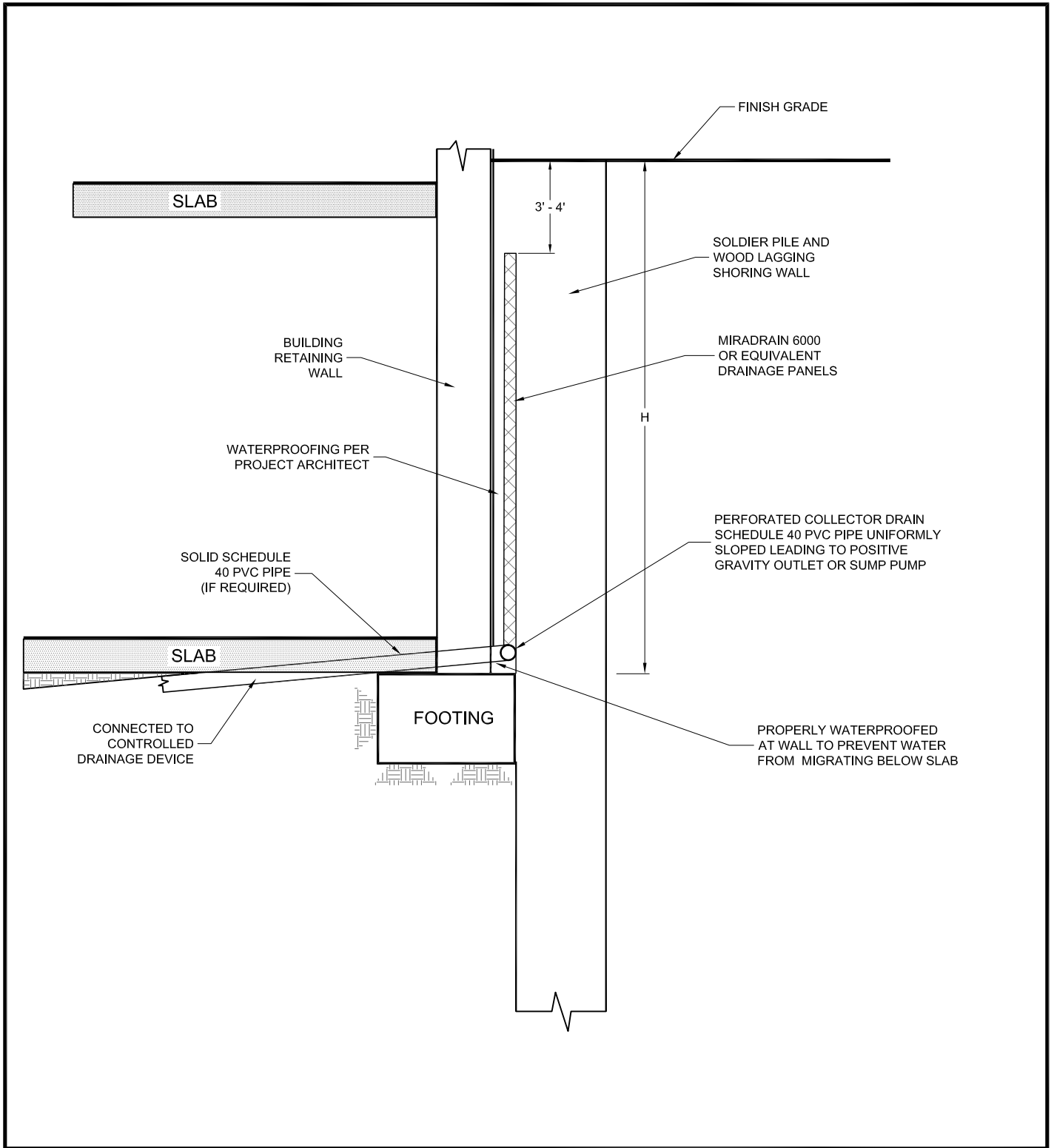

SOLDIER PILE WALL DRAINAGE DETAIL

GEOCON
INCORPORATED

GEOTECHNICAL ■ ENVIRONMENTAL ■ MATERIALS
6960 FLANDERS DRIVE - SAN DIEGO, CALIFORNIA 92121 - 2974
PHONE 858 558-6900 - FAX 858 558-6159

AG / AML

DSK/GTYPD

STRAUSS FIFTH AVENUE APARTMENTS
SAN DIEGO, CALIFORNIA

DATE 05 - 08 - 2015 PROJECT NO. G1815 - 11 - 01 FIG. 10

APPENDIX

A

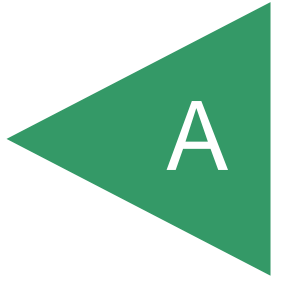

APPENDIX A

FIELD INVESTIGATION

Fieldwork for our geotechnical investigation included a site visit, subsurface exploration, and soil sampling. The approximate locations of the exploratory borings are shown on the Geologic Map, Figure 2. Boring logs are presented in figures following the text in this appendix. We located the borings in the field using a measuring tape and existing reference points. Therefore, actual boring locations may deviate slightly.

We performed our subsurface exploration on March 5 and 6, 2015, and included the drilling and sampling of existing soils with a CME 85 drill rig equipped with 8-inch hollow-stem augers. We obtained samples during our subsurface exploration using a California split-spoon sampler. The California sampler has an inside diameter of 2.5 inches and an outside diameter of 2.875 inches. Up to 18 rings are placed inside the sampler that is 2.4 inches in diameter and 1 inch in height. We obtained ring samples in moisture-tight containers at appropriate intervals and transported them to the laboratory for testing. We also obtained disturbed bulk soil samples from the borings for laboratory testing. The type of sample is noted on the exploratory boring logs.

The samplers were driven 12 inches into the bottom of the excavations with the use of an automatic down-hole hammer. The sampler is driven into the bottom of the excavation by dropping a 140-pound hammer from height of 30-inches. Blow counts are recorded for every 6 inches the sampler is driven. The penetration resistances shown on the boring logs are shown in terms of blows per foot. The values indicated on the boring logs are the sum of the last 12 inches the sampler was driven. An approximate value is calculated in term of blows per foot or the final 6-inch interval is reported. These values are not to be taken as N-values, adjustments have not been applied.







The soil conditions encountered in the borings were visually examined, classified and logged in general accordance with the American Society for Testing and Materials (ASTM) Practice for Description and Identification of Soils (Visual-Manual Procedure D 2488). Figures A-1 through A-4 present the logs of the exploratory borings. The logs depict the various soil types encountered and indicate the depths at which samples were obtained. The elevations shown on the boring logs were determined using a topographic map provided by Omega Land Surveying, Incorporated.

A copy of the County of San Diego Department of Environmental Health Geotechnical Boring Construction Permit has been included.

DEPTH IN FEET	SAMPLE NO.	LITHOLOGY	GROUNDWATER	SOIL CLASS (USCS)	BORING B 1		PENETRATION RESISTANCE (BLOWS/FT.)	DRY DENSITY (P.C.F.)	MOISTURE CONTENT (%)
					ELEV. (MSL.) <u>288.5'</u>	DATE COMPLETED <u>03-05-2015</u>			
					EQUIPMENT <u>CME 85 w/8" HSA</u>		BY: <u>A. GASTELUM</u>		
MATERIAL DESCRIPTION									
0				SM	4" ASPHALT CONCRETE				
2					UNDOCUMENTED FILL (Qudf) Medium dense, moist, dark brown, Silty, fine to medium SAND; trace fine to medium gravel; organic odor				
4	B1-1 B1-2			SM	VERY OLD PARALIC DEPOSITS (Qvop) Very dense, damp, light reddish brown, Silty, fine- to medium-grained SANDSTONE; weakly cemented		50/6"	99.4	5.6
10	B1-3				-Becomes moist -12" zone with few medium to coarse gravel; subangular		50/6"	105.5	8.2
14	B1-4				-12" zone with few medium to coarse gravel; subangular		50/5"	105.0	10.9
20	B1-5				-Trace fine to medium subangular cobbles		50/6"	123.4	6.8
26	B1-6			SM	-Becomes fine- to coarse-grained; slightly micaceous		50/5"	116.9	10.7
28					SAN DIEGO FORMATION (Tsd) Very dense, damp to moist, light olive gray, Silty, fine grained SANDSTONE; massive bedding				
30	B1-7 B1-8						79/9"	93.5	16.1
34									

Figure A-1,
Log of Boring B 1, Page 1 of 2

G1815-11-01.GPJ

SAMPLE SYMBOLS	 ... SAMPLING UNSUCCESSFUL	 ... STANDARD PENETRATION TEST	 ... DRIVE SAMPLE (UNDISTURBED)
	 ... DISTURBED OR BAG SAMPLE	 ... CHUNK SAMPLE	 ... WATER TABLE OR SEEPAGE

NOTE: THE LOG OF SUBSURFACE CONDITIONS SHOWN HEREON APPLIES ONLY AT THE SPECIFIC BORING OR TRENCH LOCATION AND AT THE DATE INDICATED. IT IS NOT WARRANTED TO BE REPRESENTATIVE OF SUBSURFACE CONDITIONS AT OTHER LOCATIONS AND TIMES.

DEPTH IN FEET	SAMPLE NO.	LITHOLOGY	GROUNDWATER	SOIL CLASS (USCS)	BORING B 1		PENETRATION RESISTANCE (BLOWS/FT.)	DRY DENSITY (P.C.F.)	MOISTURE CONTENT (%)	
					ELEV. (MSL.) <u>288.5'</u>	DATE COMPLETED <u>03-05-2015</u>				
					EQUIPMENT <u>CME 85 w/8" HSA</u>		BY: <u>A. GASTELUM</u>			
MATERIAL DESCRIPTION										
36	B1-9				-Iron oxide stained banding; weakly cemented		82/10"	87.3	9.8	
38										
40	B1-10							50/6"	93.6	12.9
42										
44										
46	B1-11							77/9"	83.0	11.2
48										
50	B1-12					-Iron oxide staining		50/5"	89.6	9.5
52										
54										
56	B1-13							50/6"	87.3	13.9
58										
60	B1-14					-Becomes light olive gray and light yellowish brown; weakly to moderately cemented		73/9"	94.3	15.4
					BORING TERMINATED AT APPROX. 61 FEET No groundwater encountered Boring backfilled with approx. 21 ft ³ of bentonite grout					

Figure A-1,
Log of Boring B 1, Page 2 of 2

G1815-11-01.GPJ







SAMPLE SYMBOLS					
	... SAMPLING UNSUCCESSFUL		... STANDARD PENETRATION TEST		... DRIVE SAMPLE (UNDISTURBED)
	... DISTURBED OR BAG SAMPLE		... CHUNK SAMPLE		... WATER TABLE OR SEEPAGE

NOTE: THE LOG OF SUBSURFACE CONDITIONS SHOWN HEREON APPLIES ONLY AT THE SPECIFIC BORING OR TRENCH LOCATION AND AT THE DATE INDICATED. IT IS NOT WARRANTED TO BE REPRESENTATIVE OF SUBSURFACE CONDITIONS AT OTHER LOCATIONS AND TIMES.

DEPTH IN FEET	SAMPLE NO.	LITHOLOGY	GROUNDWATER	SOIL CLASS (USCS)	BORING B 2		PENETRATION RESISTANCE (BLOWS/FT.)	DRY DENSITY (P.C.F.)	MOISTURE CONTENT (%)
					ELEV. (MSL.) <u>292.5'</u>	DATE COMPLETED <u>03-05-2015</u>			
					EQUIPMENT <u>CME 85 w/8" HSA</u>		BY: <u>A. GASTELUM</u>		
MATERIAL DESCRIPTION									
0				SC	3" ASPHALT CONCRETE				
2					UNDOCUMENTED FILL (Qudf) Medium dense, moist, reddish brown to brown, Clayey, fine to medium SAND				
4	B2-1			SM	VERY OLD PARALIC DEPOSITS (Qvop) Very dense, damp to moist, reddish brown, Silty, fine- to medium-grained SANDSTONE; weakly cemented		50/4"	110.6	9.0
10	B2-2			SC	Very dense, moist, reddish brown, Clayey, fine- to coarse-grained SANDSTONE -12" zone of fine to medium subrounded gravel		50/6"	107.6	11.9
16	B2-3			SM	Very dense, moist, reddish brown, Silty, fine- to medium-grained SANDSTONE		50/6"	95.0	8.8
26	B2-4				-Becomes yellowish brown; fine- to coarse-grained		50/5"	92.8	5.8
30				GP	Very dense, moist, Cobble CONGLOMERATE; yellowish brown; silty sand matrix -No recovery due to 3" cobble obstruction		50/4"		
34				SM	SAN DIEGO FORMATION (Tsd) Very dense, damp to moist, light olive gray and light yellowish brown, Silty, fine-grained SANDSTONE				

Figure A-2,
Log of Boring B 2, Page 1 of 2

G1815-11-01.GPJ

SAMPLE SYMBOLS	 ... SAMPLING UNSUCCESSFUL	 ... STANDARD PENETRATION TEST	 ... DRIVE SAMPLE (UNDISTURBED)
	 ... DISTURBED OR BAG SAMPLE	 ... CHUNK SAMPLE	 ... WATER TABLE OR SEEPAGE

NOTE: THE LOG OF SUBSURFACE CONDITIONS SHOWN HEREON APPLIES ONLY AT THE SPECIFIC BORING OR TRENCH LOCATION AND AT THE DATE INDICATED. IT IS NOT WARRANTED TO BE REPRESENTATIVE OF SUBSURFACE CONDITIONS AT OTHER LOCATIONS AND TIMES.

DEPTH IN FEET	SAMPLE NO.	LITHOLOGY	GROUNDWATER	SOIL CLASS (USCS)	BORING B 2		PENETRATION RESISTANCE (BLOWS/FT.)	DRY DENSITY (P.C.F.)	MOISTURE CONTENT (%)
					ELEV. (MSL.) <u>292.5'</u>	DATE COMPLETED <u>03-05-2015</u>			
					EQUIPMENT <u>CME 85 w/8" HSA</u> BY: <u>A. GASTELUM</u>				
					MATERIAL DESCRIPTION				
36	B2-5						50/6"	87.6	14.9
38									
40	B2-6					-Becomes light gray; minor iron-oxide staining		50/5"	88.5
42									
44									
46	B2-7						79/9"	85.4	13.2
					BORING TERMINATED AT APPROX. 46 FEET No groundwater encountered Boring backfilled with approx. 15.5 ft ³ of bentonite grout				

Figure A-2,
Log of Boring B 2, Page 2 of 2

G1815-11-01.GPJ

SAMPLE SYMBOLS	... SAMPLING UNSUCCESSFUL	... STANDARD PENETRATION TEST	... DRIVE SAMPLE (UNDISTURBED)
	... DISTURBED OR BAG SAMPLE	... CHUNK SAMPLE	... WATER TABLE OR SEEPAGE

NOTE: THE LOG OF SUBSURFACE CONDITIONS SHOWN HEREON APPLIES ONLY AT THE SPECIFIC BORING OR TRENCH LOCATION AND AT THE DATE INDICATED. IT IS NOT WARRANTED TO BE REPRESENTATIVE OF SUBSURFACE CONDITIONS AT OTHER LOCATIONS AND TIMES.

DEPTH IN FEET	SAMPLE NO.	LITHOLOGY	GROUNDWATER	SOIL CLASS (USCS)	BORING B 3		PENETRATION RESISTANCE (BLOWS/FT.)	DRY DENSITY (P.C.F.)	MOISTURE CONTENT (%)
					ELEV. (MSL.) <u>290.0</u>	DATE COMPLETED <u>03-06-2015</u>			
					EQUIPMENT <u>CME 85 w/8" HSA</u>		BY: <u>A. GASTELUM</u>		
MATERIAL DESCRIPTION									
0	B3-1			SC	4" ASPHALT CONCRETE		24	105.2	13.6
2	B3-2				UNDOCUMENTED FILL (Qudf) Medium dense, moist, dark reddish brown, Clayey, fine to medium SAND; mottled with yellowish brown; trace fine gravel		26		
	B3-3								123.6
4	B3-4			SC	VERY OLD PARALIC DEPOSITS (Qvop) Very dense, moist, reddish brown and olive gray, Clayey, fine- to medium-grained SANDSTONE		50/6"	116.9	12.8
10	B3-5			SM	Very dense, moist, reddish brown and yellowish brown, Silty, fine- to medium-grained SANDSTONE		50/5"	95.5	6.9
16	B3-6				-Becomes reddish brown; lensed with light olive gray		50/6"	109.8	11.4
20					-No recovery		50/6"		
24					-24" zone of fine to medium subrounded cobbles				
26					-No recovery		50/6"		
28				SM	SAN DIEGO FORMATION (Tsd) Very dense, moist, light olive gray, Silty, fine-grained SANDSTONE				
30	B3-7						50/6"	78.0	13.9
32									
34									

Figure A-3,
Log of Boring B 3, Page 1 of 2

G1815-11-01.GPJ

SAMPLE SYMBOLS		... SAMPLING UNSUCCESSFUL		... STANDARD PENETRATION TEST		... DRIVE SAMPLE (UNDISTURBED)
		... DISTURBED OR BAG SAMPLE		... CHUNK SAMPLE		... WATER TABLE OR SEEPAGE

NOTE: THE LOG OF SUBSURFACE CONDITIONS SHOWN HEREON APPLIES ONLY AT THE SPECIFIC BORING OR TRENCH LOCATION AND AT THE DATE INDICATED. IT IS NOT WARRANTED TO BE REPRESENTATIVE OF SUBSURFACE CONDITIONS AT OTHER LOCATIONS AND TIMES.

DEPTH IN FEET	SAMPLE NO.	LITHOLOGY	GROUNDWATER	SOIL CLASS (USCS)	BORING B 3		PENETRATION RESISTANCE (BLOWS/FT.)	DRY DENSITY (P.C.F.)	MOISTURE CONTENT (%)	
					ELEV. (MSL.) <u>290.0</u>	DATE COMPLETED <u>03-06-2015</u>				
					EQUIPMENT <u>CME 85 w/8" HSA</u> BY: <u>A. GASTELUM</u>					
					MATERIAL DESCRIPTION					
36	B3-8						84	102.0	14.4	
38										
40	B3-9				-Becomes light gray		81	91.5	10.4	
42	B3-10									
44										
46	B3-11				-Becomes light olive gray		79	84.6	10.2	
					BORING TERMINATED AT 46 FEET No groundwater encountered Boring backfilled with approx. 15.5 ft ³ of bentonite grout					

Figure A-3,
Log of Boring B 3, Page 2 of 2

G1815-11-01.GPJ







SAMPLE SYMBOLS	... SAMPLING UNSUCCESSFUL	... STANDARD PENETRATION TEST	... DRIVE SAMPLE (UNDISTURBED)
	... DISTURBED OR BAG SAMPLE	... CHUNK SAMPLE	... WATER TABLE OR SEEPAGE

NOTE: THE LOG OF SUBSURFACE CONDITIONS SHOWN HEREON APPLIES ONLY AT THE SPECIFIC BORING OR TRENCH LOCATION AND AT THE DATE INDICATED. IT IS NOT WARRANTED TO BE REPRESENTATIVE OF SUBSURFACE CONDITIONS AT OTHER LOCATIONS AND TIMES.

DEPTH IN FEET	SAMPLE NO.	LITHOLOGY	GROUNDWATER	SOIL CLASS (USCS)	BORING B 4		PENETRATION RESISTANCE (BLOWS/FT.)	DRY DENSITY (P.C.F.)	MOISTURE CONTENT (%)
					ELEV. (MSL.) <u>292.0'</u>	DATE COMPLETED <u>03-06-2015</u>			
					EQUIPMENT <u>CME 85 w/8" HSA</u>		BY: <u>A. GASTELUM</u>		
MATERIAL DESCRIPTION									
0				SM	3" ASPHALT CONCRETE				
2					UNDOCUMENTED FILL Medium dense, moist, dark reddish brown, Clayey, fine to medium SAND				
4					VERY OLD PARALIC DEPOSIT (Qvop) Very dense, moist, reddish brown, Silty, fine- to coarse-grained SANDSTONE; trace fine gravel; uncemented				
6	B4-1						50/6"	107.8	8.6
10	B4-2 B4-3				-Becomes reddish brown and yellowish brown		50/5"	113.7	12.7
16	B4-4				-Trace fine subrounded cobbles		50/6"	98.7	10.5
20	B4-5				-Becomes reddish brown		50/5"	102.2	8.8
26	B4-6				-Poor sample recovery		50/4"		
30	B4-7				-Becomes yellowish brown; fine-grained		85/9"	103.3	7.6
32				SM	SAN DIEGO FORMATION (Tsd) Very dense, moist, light olive brown and light yellowish brown, Silty, fine-grained SANDSTONE; uncemented				
34									

Figure A-4,
Log of Boring B 4, Page 1 of 2

G1815-11-01.GPJ

SAMPLE SYMBOLS	 ... SAMPLING UNSUCCESSFUL	 ... STANDARD PENETRATION TEST	 ... DRIVE SAMPLE (UNDISTURBED)
	 ... DISTURBED OR BAG SAMPLE	 ... CHUNK SAMPLE	 ... WATER TABLE OR SEEPAGE

NOTE: THE LOG OF SUBSURFACE CONDITIONS SHOWN HEREON APPLIES ONLY AT THE SPECIFIC BORING OR TRENCH LOCATION AND AT THE DATE INDICATED. IT IS NOT WARRANTED TO BE REPRESENTATIVE OF SUBSURFACE CONDITIONS AT OTHER LOCATIONS AND TIMES.

DEPTH IN FEET	SAMPLE NO.	LITHOLOGY	GROUNDWATER	SOIL CLASS (USCS)	BORING B 4		PENETRATION RESISTANCE (BLOWS/FT.)	DRY DENSITY (P.C.F.)	MOISTURE CONTENT (%)	
					ELEV. (MSL.) <u>292.0'</u>	DATE COMPLETED <u>03-06-2015</u>				
					EQUIPMENT <u>CME 85 w/8" HSA</u>		BY: <u>A. GASTELUM</u>			
MATERIAL DESCRIPTION										
36	B4-8				-Becomes light olive gray; iron-oxide banding		50/6"	85.3	14.5	
38										
40	B4-9							92/10"	95.3	12.9
42										
44										
46	B4-10							79/11"	86.8	10.3
48										
50	B4-11						80	84.6	10.6	
52										
54										
56	B4-12						79	83.8	9.7	
58										
60	B4-13						78	90.6	7.2	
					BORING TERMINATED AT 61 FEET No groundwater encountered Boring backfilled with approx. 21 ft ³ of bentonite grout					

Figure A-4,
Log of Boring B 4, Page 2 of 2

G1815-11-01.GPJ

SAMPLE SYMBOLS		... SAMPLING UNSUCCESSFUL		... STANDARD PENETRATION TEST		... DRIVE SAMPLE (UNDISTURBED)
		... DISTURBED OR BAG SAMPLE		... CHUNK SAMPLE		... WATER TABLE OR SEEPAGE

NOTE: THE LOG OF SUBSURFACE CONDITIONS SHOWN HEREON APPLIES ONLY AT THE SPECIFIC BORING OR TRENCH LOCATION AND AT THE DATE INDICATED. IT IS NOT WARRANTED TO BE REPRESENTATIVE OF SUBSURFACE CONDITIONS AT OTHER LOCATIONS AND TIMES.



PERMIT # LMWP-001583
 A.P.N. # 452-406-14, -15, -17
 EST # 154670-HMD

**COUNTY OF SAN DIEGO
 DEPARTMENT OF ENVIRONMENTAL HEALTH
 LAND AND WATER QUALITY DIVISION
 MONITORING WELL PROGRAM
GEOTECHNICAL BORING CONSTRUCTION PERMIT**

SITE NAME: STRAUSS FIFTH AVENUE APARTMENTS
 SITE ADDRESS: 3500 5TH AVE., SAN DIEGO, CA 92103
 PERMIT FOR: **4 GEOTECHNICAL BORINGS**
 PERMIT APPROVAL DATE: MARCH 5, 2015
 PERMIT EXPIRES ON: JULY 3, 2015
 RESPONSIBLE PARTY: DANUBE PROPERTIES, INC.

PERMIT CONDITIONS:

1. All borings must be sealed from the bottom of the boring to the ground surface with an approved sealing material as specified in California Well Standards Bulletin 74-90, Part III, Section 19.D. **Drill cuttings are not an acceptable fill material.**
2. All borings must be properly destroyed within 24 hours of drilling.
3. Placement of any sealing material at a depth greater than 30 feet must be done using the tremie method.
4. This work is not connected to any known unauthorized release of hazardous substances. Any contamination found in the course of drilling and sampling must be reported to DEH. All water and soil resulting from the activities covered by this permit must be managed, stored and disposed of as specified in the SAM Manual in Section 5, II, D-4. (http://www.sdcountry.ca.gov/deh/lwq/sam/manual_guidelines.html) In addition, drill cuttings must be properly handled and disposed in compliance with the Stormwater Best Management Practices of the local jurisdiction.
5. Within 60 days of completing work, submit a well/boring construction report, including all well and/or boring logs and laboratory data to the Well Permit Desk. This report must include all items required by the SAM Manual, Section 5, Pages 6 & 7.
6. **This office must be given 48-hour notice of any drilling activity on this site and advanced notification of drilling cancellation. Please contact the Well Permit Desk at (858) 505-6688.**

APPROVED BY: 

Digitally signed by Veronica Tavizon-Hitchner
 DN: cn=Veronica Tavizon-Hitchner, o=DEH/
 LWQ/MWP, ou=County of San Diego,
 email=veronica.tavizon@sdcounty.ca.gov, c=US
 Date: 2015.03.05 07:53:50 -08'00'

VERONICA TAVIZON

DATE: 03/05/2015

APPENDIX

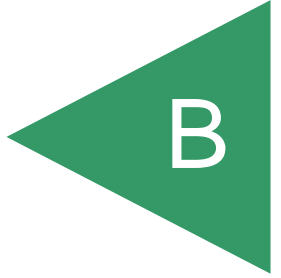

APPENDIX B

LABORATORY TESTING

We performed the laboratory tests in accordance with the currently accepted versions of the generally accepted American Society for Testing Materials (ASTM) procedures or other suggested procedures. We tested selected soil samples for their in-place density and moisture content, maximum dry density and optimum moisture content, shear strength, expansion index, water-soluble sulfate, pH and resistivity, chloride ion content, and unconfined compressive strength. The results of our laboratory tests are presented on Tables B-I through B-VII and on the boring logs in Appendix A.

**TABLE B-I
SUMMARY OF LABORATORY MAXIMUM DRY DENSITY AND
OPTIMUM MOISTURE CONTENT TEST RESULTS
ASTM D 1557**

Sample No.	Depth (feet)	Description	Maximum Dry Density (pcf)	Optimum Moisture Content (% dry wt.)
B1-8	30-35	Light olive brown, Silty, fine SAND	121.4	11.7

**TABLE B-II
SUMMARY OF LABORATORY DIRECT SHEAR TEST RESULTS
ASTM D 3080**

Sample No.	Depth (feet)	Geologic Unit	Dry Density (pcf)	Moisture Content (%)		Unit Peak [Ultimate ¹] Cohesion (psf)	Angle of Peak [Ultimate ¹] Shear Resistance (degrees)
				Initial	Final		
B1-7	30	Tsd	93.5	16.1	29.6	350 [350]	30 [30]
B1-11	45	Tsd	83.0	11.2	34.9	325 [325]	30 [30]
B2-2	10	Qvop	107.6	11.9	19.1	625 [225]	29 [29]
B3-6	15	Qvop	109.8	11.4	17.1	350 [350]	30 [30]

¹ Ultimate at end of test at 0.2 inch deflection

**TABLE B-III
SUMMARY OF LABORATORY EXPANSION INDEX TEST RESULTS
ASTM D 4829**

Sample No.	Depth (feet)	Geologic Unit	Moisture Content (%)		Dry Density (pcf)	Expansion Index	Expansion Classification	2013 CBC Expansion Classification
			Before Test	After Test				
B1-8	30-35	Tsd	9.7	19.0	106.9	12	Very Low	Non-Expansive
B3-10	40-45	Tsd	10.8	20.3	105.3	7	Very Low	Non-Expansive
B4-3	10-15	Qvop	9.5	18.7	109.3	14	Very Low	Non-Expansive

**TABLE B-IV
SUMMARY OF LABORATORY WATER-SOLUBLE SULFATE TEST RESULTS
CALIFORNIA TEST NO. 417**

Sample No.	Depth (Feet)	Water-Soluble Sulfate (%)	Sulfate Severity	Sulfate Class
B1-8	30-35	0.004	Not Applicable	S0
B3-10	40-45	0.006	Not Applicable	S0
B4-3	10-15	0.005	Not Applicable	S0

**TABLE B-V
SUMMARY OF LABORATORY POTENTIAL OF HYDROGEN (PH) AND RESISTIVITY TEST RESULTS
CALIFORNIA TEST NO. 643**

Sample No.	Depth (Feet)	Geologic Unit	pH	Minimum Resistivity (ohm-centimeters)
B1-8	30-35	Tsd	7.80	3,300

**TABLE B-VI
SUMMARY OF LABORATORY WATER-SOLUBLE CHLORIDE ION CONTENT TEST RESULTS
AASHTO TEST NO. T 291**

Sample No.	Chloride Ion Content (%)	Chloride Ion Content (ppm)
B1-8	0.008	81
B4-3	0.008	81

**TABLE B-VII
SUMMARY OF IN-SITU UNCONFINED COMPRESSIVE STRENGTH TEST RESULTS
ASTM D 1558**

Sample No.	Depth (feet)	Geologic Unit	Hand Penetrometer Reading, Unconfined Compression Strength (tsf)	Undrained Shear Strength (ksf)
B1-1	5	Qvop	3.5	3.5
B1-3	10	Qvop	3.5	3.5
B1-5	20	Qvop	4.0	4.0
B1-7	30	Tsd	3.5	3.5
B1-9	35	Tsd	3.5	3.5
B1-10	40	Tsd	4.0	4.0
B1-11	45	Tsd	3.5	3.5
B1-14	60	Tsd	4.5	4.5
B2-1	5	Qvop	4.5	4.5
B2-5	35	Tsd	3.0	3.0
B2-6	40	Tsd	4.5	4.5
B2-7	45	Tsd	4.0	4.0
B3-3	2.5	Qudf	4.0	4.0
B3-4	5	Qvop	4.5	4.5
B3-5	10	Qvop	3.5	3.5
B3-6	15	Qvop	4.5	4.5
B3-9	40	Tsd	4.5	4.5
B4-1	5	Qvop	4.5	4.5
B4-2	10	Qvop	4.5	4.5
B4-5	20	Qvop	3.5	3.5
B4-7	30	Qvop	4.0	4.0
B4-8	35	Tsd	4.0	4.0
B4-9	40	Tsd	4.5	4.5
B4-10	45	Tsd	4.5	4.5
B4-11	50	Tsd	4.5	4.5
B4-12	55	Tsd	3.0	3.0
B4-13	60	Tsd	4.5	4.5

LIST OF REFERENCES

1. 2013 California Building Code, *California Code of Regulations, Title 24, Part 2*, based on the 2012 International Building Code, prepared by California Building Standards Commission, dated July, 2013.
2. ACI 318-11, *Building Code Requirements for Structural Concrete and Commentary*, prepared by the American Concrete Institute, dated August, 2011.
3. ACI 330-08, *Guide for the Design and Construction of Concrete Parking Lots*, prepared by the American Concrete Institute, dated June 2008.
4. ASCE 7-10, *Minimum Design Loads for Buildings and Other Structures*, Second Printing, April 6, 2011.
5. Boore, D. M., and G. M Atkinson (2008), *Ground-Motion Prediction for the Average Horizontal Component of PGA, PGV, and 5%-Damped PSA at Spectral Periods Between 0.01 and 10.0 S, Earthquake Spectra*, Volume 24, Issue 1, pages 99-138, February 2008.
6. California Geologic Survey, *Seismic Shaking Hazards in California*, based on the USGS/CGS Probabilistic Seismic Hazards Assessment (PSHA) Model, 2002 (revised April 2003). 10% probability of being exceeded in 50 years.
<http://redirect.conservacion.ca.gov/cgs/rghm/pshamap/pshamain.html>
7. Campbell, K. W., Y. Bozorgnia, *NGA Ground Motion Model for the Geometric Mean Horizontal Component of PGA, PGV, PGD and 5% Damped Linear Elastic Response Spectra for Periods Ranging from 0.01 to 10 s*, Preprint of version submitted for publication in the NGA Special Volume of Earthquake Spectra, Volume 24, Issue 1, pages 139-171, February 2008.
8. Carrier Johnson + Culture, *Architectural Plans for Strauss 5th and Walnut, San Diego, California*, dated May 1, 2015 (Project No. 5548.00).
9. Chiou, Brian S. J., and Robert R. Youngs, *A NGA Model for the Average Horizontal Component of Peak Ground Motion and Response Spectra*, preprint for article to be published in NGA Special Edition for Earthquake Spectra, Spring 2008.
10. *City of San Diego Seismic Safety Study, Geologic Hazards and Faults*, 2008, Map Sheet 21.
11. Kennedy, M. P., and S. S. Tan, 2008, *Geologic Map of the San Diego 30'x60' Quadrangle, California*, USGS Regional Map Series Map No. 3, Scale 1:100,000.
12. Risk Engineering, *EZ-FRISK, (Version 7.65)*, 2012.
13. United States Geological Survey computer program, *U.S. Seismic Design Maps*, <http://earthquake.usgs.gov/designmaps/us/application.php>.
14. Unpublished Geotechnical Reports and Information, Geocon Incorporated.