



PLANNING DEPARTMENT

Date of Notice: March 22, 2019

**PUBLIC NOTICE OF AVAILABILITY FOR
A DRAFT MITIGATED NEGATIVE DECLARATION**

Internal Order No. 23430379

PUBLIC NOTICE: The City of San Diego Planning Department has prepared a draft Mitigated Negative Declaration (MND) for the following project and is inviting your comments regarding the adequacy of the document. The draft MND and associated technical appendices have been placed on the City of San Diego Planning Department website under the heading "Draft CEQA Documents" and can be accessed using the following link:

<http://www.sandiego.gov/planning/programs/ceqa>

The draft MND public notice has also been placed on the City Clerk website at:

<http://www.sandiego.gov/city-clerk/officialdocs/notices/index.shtml>

Your comments must be received by May 3, 2019 to be included in the final document considered by the decision-making authorities. Please send your written comments to the following address: **Myra Herrmann, Environmental Planner, City of San Diego Planning Department, 9485 Aero Drive, MS 413, San Diego, CA 92123-1801** or e-mail your comments to PlanningCEQA@sandiego.gov with the Project Name and Number in the subject line. Please note that only written comments, received either via US Mail, hand-delivered, or via email, will be considered official comments in the Final MND.

PROJECT NAME: **10325 Roselle Street**
PROJECT No. **150566** / SCH No. *Pending*
COMMUNITY PLAN AREA: **Torrey Pines**
COUNCIL DISTRICT: **1 (Bry)**
APPLICANT: **CLL-Roselle, LLC**

PROJECT DESCRIPTION:

Site Development Permit (SDP) and Coastal Development Permit (CDP) to allow for the remediation of impacts associated with a grading violation that occurred on the site by a former tenant which resulted in the placement of unauthorized fill material impacting biological, archaeological and tribal cultural resources. The project site contains sensitive biological resources, a designated important archaeological/tribal cultural resource (HRB Site #924), and steep hillsides. As part of the site remediation, the project will recontour the fill material to create a 100-foot native-landscaping buffer to protect the wetlands, and build a pad that would be suitable for an equipment, materials, or vehicle storage yard, consistent with the community plan land use (Industrial) and zoning (IL-3-1) designations. A mobile office trailer will be placed close to the existing water and sewer facilities to minimize ground disturbance. Minor and routine vehicle maintenance would be allowed within a small area of the project site; however, the storage of inoperable vehicles or hazardous/toxic materials will not be allowed on this site. The pad area and access driveway will be surfaced with decomposed granite and all storm water runoff will be treated onsite and conveyed through a newly constructed storm drain, and into the existing storm drain system along the northwest property line on Roselle Street. The approximately 1.5-acre pad area would be fenced, and an open space easement placed over the balance of the site to protect the sensitive biological/wetland resources. A landscape plan, designed and prepared in consultation

with the project biologist, archaeologist and Native American Kumeyaay consultant is proposed along the Roselle Street frontage to provide a native plant palette with minimal ground-disturbing impacts.

The unauthorized grading and fill placement resulted in impacts to 0.02 acre of southern willow scrub and an important archaeological/tribal cultural resource site. To mitigate this impact, the project requires onsite enhancement of 0.42-acre of southern willow scrub, maintenance and seeding of the wetland buffer zone (approximately 1.53 acres), weed and exotic species removal adjacent to the wetlands enhancement area, and implementation of a five-year maintenance and monitoring program to meet performance standards. Although the unauthorized fill material that was placed on the site will remain in place, acting as a cap to protect the important archaeological and tribal cultural resources, pursuant to the City's Land Development Code (LDC) Historical Resources Regulation and associated Land Development Manual (LDM) Historical Resources Guidelines, some recontouring will be required to create the wetland buffer and pad area, and fencing to provide additional security to the site to protect the resources. Site grading/recontouring of the fill material will require implementation of an Archaeological Data Recovery Program and subsequent monitoring of all ground-disturbing activities by a qualified archaeologist and Native American Kumeyaay cultural consultant. The site grading/contouring has been designed to avoid further impacts to sensitive biological, archaeological and tribal cultural resources, and to avoid encroachment into the steep hillsides.

PROJECT LOCATION:

The project is located on an approximately 7.0-acre site at 10325 Roselle Street in an area predominately made up of industrial development in the southern portion of the Torrey Pines Community Planning Area within Sorrento Valley. The site is designated Industrial and is within the IL-3-1 and Coastal Overlay Zone (Appealable & Non-Appealable Area 1). Carroll Canyon Creek passes through the northwest portion of the property, becoming Soledad canyon within the property boundary. The project site is located on the Federal Emergency Management Agency's (FEMA) Flood Insurance Rate Map (FIRM), Community Panel No. 06073C1339G, dated May 16, 2012, for the City of San Diego, California, updated and revised pursuant to Letter of Map Revision (LOMR) Determination Document effective July 24, 2017 and revised the effective National Flood Insurance Program (NFIP) map panel (Panel 1339 of 2375) associated with the project site. The project site is also located in the Accident Potential Zone 2 for MCAS Miramar and the 60 dB CNEL contour as indicated in the adopted ALUCP for MCAS Miramar.

Recommended Finding: The draft MND concludes that the project will not have a significant effect on the environment is based on an Initial Study and project conditions which now mitigate potentially significant environmental impacts in the following area(s): **Biological Resources and Historical Resources (Archaeology and Tribal Cultural Resources)**. All other impacts analyzed in this DMND were found to be less than significant.

Availability in Alternative Format: To request this Notice, the draft MND, Initial Study, and/or supporting documents in alternative format, please call the Planning Department at (619) 235-5200 or (800) 735-2929 (TEXT TELEPHONE).

Additional Information: For environmental review information, contact Myra Herrmann at (619) 446-5372. The draft MND and supporting documents may be reviewed, or purchased for the cost of reproduction, in the Planning Department at 9485 Aero Drive, MS 413, San Diego, CA 92123. **For information regarding public meetings/hearings on this project, contact Helene Deisher in the Development Services Department at (619) 446-5223 or via email at hmdeisher@sandiego.gov.**

This notice was published in the SAN DIEGO DAILY TRANSCRIPT and distributed on:
March 22, 2019.

Alyssa Muto
Deputy Director
Planning Department

DRAFT

MITIGATED NEGATIVE DECLARATION

Project No. 150566

SCH# Pending

PROJECT DESCRIPTION: 10325 Roselle Street. Site Development Permit and Coastal Development Permit to allow for the remediation of impacts associated with a grading violation that occurred on the site by a former tenant which resulted in the placement of unauthorized fill material on the project site. The project site contains sensitive biological resources, a designated important archaeological/tribal cultural resource (HRB Site #924), and steep hillsides. As part of the site remediation, the project will recontour the fill material to create a 100-foot native-landscaping buffer to protect the wetlands, and build a pad that would be suitable for an equipment, materials, or vehicle storage yard, consistent with the community plan land use (Industrial) and zoning (IL-3-1) designations. A mobile office trailer will be placed close to the existing water and sewer facilities to minimize ground disturbance. Minor and routine vehicle maintenance would be allowed within a small area of the project site; however, the storage of inoperable vehicles or hazardous/toxic materials will not be allowed on this site. The pad area and access driveway will be surfaced with decomposed granite and all storm water runoff will be treated onsite and conveyed through a newly constructed storm drain, and into the existing storm drain system along the northwest property line on Roselle Street. The approximately 1.5-acre pad area would be fenced, and an open space easement placed over the balance of the site to protect the sensitive biological/wetland resources. A landscape plan, designed and prepared in consultation with the project biologist, archaeologist and Native American Kumeyaay consultant is proposed along the Roselle Street frontage to provide a native plant palette with minimal ground-disturbing impacts.

The unauthorized grading and fill placement resulted in impacts to 0.02 acre of southern willow scrub and an important archaeological/tribal cultural resource site. To mitigate this impact, the project requires onsite enhancement of 0.42-acre of southern willow scrub, maintenance and seeding of the wetland buffer zone (approximately 1.53 acres), weed and exotic species removal adjacent to the wetlands enhancement area, and implementation of a five-year maintenance and monitoring program to meet performance standards. Although the unauthorized fill material that was placed on the site will remain in place, acting as a cap to protect the important archaeological and tribal cultural resources, pursuant to the City's Land Development Code (LDC) Historical Resources Regulation and associated Land Development Manual (LDM) Historical Resources Guidelines, some recontouring will be required to create the wetland buffer and pad area, and fencing to provide additional security to the site to protect the resources. Site grading/recontouring of the fill material will require implementation of an Archaeological Data Recovery Program and subsequent monitoring of all ground-disturbing activities by a qualified archaeologist and Native American Kumeyaay cultural consultant. The site grading/contouring has been designed to avoid further impacts to sensitive biological, archaeological and tribal cultural resources, and to avoid encroachment into the steep hillsides.

The project is located on an approximately 7.0-acre site at 10325 Roselle Street in an area predominately made up of industrial development in the southern portion of the Torrey Pines Community Planning Area within Sorrento Valley. The site is designated Industrial and is within the IL-3-1 and Coastal Overlay Zone (Appealable & Non-Appealable Area 1). Carroll Canyon Creek passes through the northwest portion of the property, becoming Soledad canyon within the property boundary. The project site is located on the Federal Emergency Management Agency's (FEMA) Flood Insurance Rate Map (FIRM), Community Panel No. 06073C1339G, dated May 16, 2012, for the City of San Diego, California, updated and revised pursuant to Letter of Map Revision (LOMR) Determination Document effective July 24, 2017 and revised the effective National Flood Insurance Program (NFIP) map panel (Panel 1339 of 2375) associated with the project site. The project site is also located in the Accident Potential Zone 2 for MCAS Miramar and the 60 dB CNEL contour as indicated in the adopted ALUCP for MCAS Miramar.

APPLICANT: CLL-Roselle, LLC

- I. PROJECT DESCRIPTION: See attached Initial Study.
- II. ENVIRONMENTAL SETTING: See attached Initial Study.
- III. DETERMINATION:

The City of San Diego conducted an Initial Study which determined that the proposed project could have a significant environmental effect in the following areas(s): Biological Resources and Historical Resources (Archaeology and Tribal Cultural Resources). The project proposal requires the implementation of specific mitigation identified in Section V of this Mitigated Negative Declaration (MND). The project as presented avoids or mitigates the potentially significant environmental effects identified, and the preparation of an Environmental Impact Report (EIR) would not be required.

- IV. DOCUMENTATION:

The attached Initial Study documents the reasons to support the above Determination.

- V. MITIGATION, MONITORING AND REPORTING PROGRAM:

A. GENERAL REQUIREMENTS – PART I
Plan Check Phase (prior to permit issuance)

- 1. Prior to the issuance of a Notice To Proceed (NTP) for a subdivision, or any construction permits, such as Demolition, Grading or Building, or beginning any construction related activity on-site, the Development Services Department (DSD) Environmental Designee (ED) shall review and approve all Construction Documents (CD), (plans, specification, details, etc.) to ensure the MMRP requirements have been incorporated.
- 2. In addition, the ED shall verify that the MMRP Conditions/Notes that apply ONLY to the construction phases of this project are included VERBATIM, under the heading, “ENVIRONMENTAL/MITIGATION REQUIREMENTS.”
- 3. These notes must be shown within the first three (3) sheets of the construction documents in the format specified for engineering construction document templates as shown on the City website:
<http://www.sandiego.gov/development-services/industry/information/standtemp.shtml>

4. The **TITLE INDEX SHEET** must also show on which pages the “Environmental/Mitigation Requirements” notes are provided.

B. GENERAL REQUIREMENTS – PART II

Post Plan Check (After permit issuance/Prior to start of construction)

1. **PRE CONSTRUCTION MEETING IS REQUIRED TEN (10) WORKING DAYS PRIOR TO BEGINNING ANY WORK ON THIS PROJECT.** The PERMIT HOLDER/OWNER is responsible to arrange and perform this meeting by contacting the CITY RESIDENT ENGINEER (RE) of the Field Engineering Division and City staff from MITIGATION MONITORING COORDINATION (MMC). Attendees must also include the Permit holder’s Representative(s), Job Site Superintendent and the following consultants:

Biologist, Archaeologist and Native American Kumeyaay Monitor

Note: Failure of all responsible Permit Holder’s representatives and consultants to attend shall require an additional meeting with all parties present.

CONTACT INFORMATION:

- a) The PRIMARY POINT OF CONTACT is the RE at the **Field Engineering Division – 858-627-3200**
 - b) For Clarification of ENVIRONMENTAL REQUIREMENTS, it is also required to call RE and MMC at **858-627-3360**
2. **MMRP COMPLIANCE:** This Project, Project Tracking System (PTS) 150566, shall conform to the mitigation requirements contained in the associated Environmental Document and implemented to the satisfaction of the DSD’s ED, MMC and the City Engineer (RE). The requirements may not be reduced or changed but may be annotated (i.e. to explain when and how compliance is being met and location of verifying proof, etc.). Additional clarifying information may also be added to other relevant plan sheets and/or specifications as appropriate (i.e., specific locations, times of monitoring, methodology, etc.)

Note: Permit Holder’s Representatives must alert RE and MMC if there are any discrepancies in the plans or notes, or any changes due to field conditions. All conflicts must be approved by RE and MMC BEFORE the work is performed.
 3. **OTHER AGENCY REQUIREMENTS:** Evidence that any other agency requirements or permits have been obtained or are in process shall be submitted to the RE and MMC for review and acceptance prior to the beginning of work or within one week of the Permit Holder obtaining documentation of those permits or requirements. Evidence shall include copies of permits, letters of resolution or other documentation issued by the responsible agency. *Not Applicable for this project.*
 4. **MONITORING EXHIBITS:** All consultants are required to submit, to RE and MMC, a monitoring exhibit on a 11x17 reduction of the appropriate construction plan, such as site plan, grading, landscape, etc., marked to clearly show the specific areas including the **LIMIT OF WORK**, scope of that discipline’s work, and notes indicating when in the construction schedule that work will be performed. When necessary for clarification, a detailed methodology of how the work will be performed shall be included.

NOTE: Surety and Cost Recovery – When deemed necessary by the Development Services Director or City Manager, additional surety instruments or bonds from the private Permit Holder may be required to ensure the long-term performance or implementation of required mitigation measures or programs. The City is authorized to recover its cost to offset the salary, overhead, and expenses for City personnel and programs to monitor qualifying projects.

5. **OTHER SUBMITTALS AND INSPECTIONS:** The Permit Holder/Owner’s representative shall submit all required documentation, verification letters, and requests for all associated inspections to the RE and MMC for approval per the following schedule:

Document Submittal/Inspection Checklist		
Issue Area	Document Submittal	Associated Inspection/Approvals/Notes
General	Consultant Qualification Letters	Prior to Preconstruction Meeting
General	Consultant Construction Monitoring Exhibits	Prior to Preconstruction Meeting
Cultural Resources	Monitoring Report(s)	Archaeology/Tribal Site Observation(s)
Biology	Biology Reports	Biology Observations
Bond Release	Request for Bond Release Letter	Final MMRP Inspections Prior to Bond Release Letter

I. HISTORICAL RESOURCES (ARCHAEOLOGICAL AND TRIBAL CULTURAL RESOURCES)

CULT-1 Archaeological Data Recovery Program

Prior to implementation of the Archaeological Data Recovery Program (ADRP) to mitigate impacts to a designated Important Archaeological Site (HRB # 924) P-37-004609/CA-SDI-4609, a pre-excavation agreement shall be developed and signed by the City of San Diego, the applicant, and the appropriate representatives of the Kumeyaay community. This agreement will specify the requirements for Native American monitors during the data recovery program and during grading for construction, the disposition of artifacts collected during the data recovery program and during construction monitoring, and the procedures to be implemented in the event that human remains are encountered during the data recovery program or during construction monitoring.

- A. **This project requires implementation of an Archaeological Data Recovery Program (ADRP) to mitigate impacts to a designated Important Archaeological Site (HRB # 924) P-37-004609/CA-SDI-4609 prior to the issuance of ANY construction permits or the start of ANY construction if no permits are required. The ADRP with Native American Kumeyaay participation consists of a statistical sample and shall be implemented after consultation with designated qualified staff (Planning department or the Development Services Department) in accordance with the Cultural Resources Report prepared by Affinis/Tim Gross in May 2009 and as updated by Helix Environmental in 2017.**
 1. **Excavation of an adequate number of units to provide a representative sample of cultural material present at the site (within the limits to be impacted, given the goal of site preservation);**

2. Water screening Water screening of a portion of the excavated sediments using 1/8-in. mesh;
 3. Standard screening of the remaining sediments using 1/8-in. mesh;
 4. Cleaning, sorting, cataloging, and analysis of all cultural material collected;
 5. Analysis of faunal material recovered;
 6. Detailed analysis of a sample of debitage collected;
 7. Obsidian sourcing and hydration analysis on a sample of artifacts;
 8. Other lithic raw material sourcing on a sample of artifacts, as appropriate;
 9. Ceramic analysis on a sample of artifacts (both petrographic and neutron activation analyses);
 10. Radiocarbon analysis;
 11. Other special studies, such as protein residue analysis, as applicable;
 12. Preparation of a comprehensive report detailing the methods and results of the data recovery program;
 13. Curation of all materials recovered during the ADRP with the exception of human remains and any associated burial goods, shall be prepared in compliance with local, state and federal standards and permanently curated at an approved facility that meets City standards;
- B. Prior to implementation of the data recovery program, a pre-excavation agreement shall be developed and signed by the City of San Diego, the applicant, and the appropriate representatives of the Kumeyaay community. This agreement will specify the requirements for Native American monitors during the data recovery program and during grading for construction, the disposition of artifacts collected during the data recovery program and during construction monitoring, and the procedures to be implemented in the event that human remains are encountered during the data recovery program or during construction monitoring.
- C. ADRP provision for the discovery of human remains shall be invoked in accordance with the California Public Resources Code, the Health and Safety Code. In the event human remains are encountered during the ADRP, soil shall only be exported from the project site after it has been cleared by the Most Likely Descendant (MLD) and the Project Archaeologist;
- D. Archaeological and Native American Monitoring shall be conducted during the remaining grading activities after completion of the ADRP and acceptance of a draft progress report for the program. The detailed Mitigation Monitoring and Reporting Program is identified below.
- E. Upon completion of the ADRP and prior to issuance of grading permits, the qualified archaeologist and Native American Monitor shall attend a second preconstruction meeting to make comments and/or suggestions concerning the proposed grading process.

CULT-2 Archaeological and Tribal Cultural Resources Monitoring Program

I. Prior to Permit Issuance

- A. Entitlements Plan Check
1. Prior to issuance of any construction permits, including but not limited to, the first Grading Permit, Demolition Plans/Permits and Building Plans/Permits or a Notice to Proceed for Subdivisions, but prior to the first preconstruction meeting, whichever is applicable, the Development Services Department (DSD) Environmental Designee (ED) shall verify that the requirements for Archaeological Monitoring and Native American participation/monitoring have been noted on the applicable construction documents through the plan check process.
- B. Letters of Qualification have been submitted to ED
1. The applicant shall submit a letter of verification to Mitigation Monitoring Coordination (MMC) identifying the Principal Investigator (PI) for the project and the names of all persons involved in the archaeological monitoring

program, as defined in the City of San Diego Historical Resources Guidelines (HRG). If applicable, individuals involved in the archaeological monitoring program must have completed the 40-hour HAZWOPER training with certification documentation.

2. MMC will provide a letter to the applicant confirming the qualifications of the PI and all persons involved in the archaeological monitoring of the project meet the qualifications established in the HRG.
3. Prior to the start of work, the applicant must obtain written approval from MMC for any personnel changes associated with the monitoring program.

II. Prior to Start of Construction

A. Verification of Records Search

1. The PI shall provide verification to MMC that a site specific records search (1/4-mile radius) has been completed. Verification includes, but is not limited to a copy of a confirmation letter from South Coastal Information Center, or, if the search was in-house, a letter of verification from the PI stating that the search was completed.
2. The letter shall introduce any pertinent information concerning expectations and probabilities of discovery during trenching and/or grading activities.
3. The PI may submit a detailed letter to MMC requesting a reduction to the 1/4 mile radius.

B. PI Shall Attend Precon Meetings

1. Prior to beginning any work that requires monitoring; the Applicant shall arrange a Precon Meeting that shall include the PI, Native American consultant/monitor (where Native American resources may be impacted), Construction Manager (CM) and/or Grading Contractor, Resident Engineer (RE), Building Inspector (BI), if appropriate, and MMC. The qualified Archaeologist and Native American Monitor shall attend any grading/excavation related Precon Meetings to make comments and/or suggestions concerning the Archaeological Monitoring program with the Construction Manager and/or Grading Contractor.
 - a. If the PI is unable to attend the Precon Meeting, the Applicant shall schedule a focused Precon Meeting with MMC, the PI, RE, CM or BI, if appropriate, prior to the start of any work that requires monitoring.
2. Identify Areas to be Monitored
 - a. Prior to the start of any work that requires monitoring, the PI shall submit an Archaeological Monitoring Exhibit (AME) (with verification that the AME has been reviewed and approved by the Native American consultant/monitor when Native American resources may be impacted) based on the appropriate construction documents (reduced to 11x17) to MMC identifying the areas to be monitored including the delineation of grading/excavation limits.
 - b. The AME shall be based on the results of a site-specific records search as well as information regarding information regarding existing known soil conditions (native or formation).
3. When Monitoring Will Occur
 - a. Prior to the start of any work, the PI shall also submit a construction schedule to MMC through the RE indicating when and where monitoring will occur.
 - b. The PI may submit a detailed letter to MMC prior to the start of work or during construction requesting a modification to the monitoring program. This request shall be based on relevant information such as review of final construction documents which indicate conditions such as review of final construction documents which indicate site conditions such as(s) depth of excavation and/or site graded to bedrock, etc., which may reduce or increase the potential for resources to be present.

III. During Construction

A. Monitor(s) Shall be Present During Grading/Excavation/Trenching

1. The Archaeological Monitor shall be present full-time during all soil disturbing and grading/excavation/trenching activities which could result in impacts to archaeological resources as identified on the AME. **The Construction Manager is responsible for notifying the RE, PI, and MMC of changes to any construction activities such as in the case of a potential safety concern within the area being monitored. In certain circumstances OSHA safety requirements may necessitate modification of the AME.**
2. The Native American consultant/monitor shall determine the extent of their presence during soil disturbing and grading/excavation/trenching activities based on the AME and provide that information to the PI and MMC. If prehistoric resources are encountered during the Native American consultant/monitor's absence, work shall stop and the Discovery Notification Process detailed in Section III.B-C and IV.A-D shall commence.
3. The PI may submit a detailed letter to MMC during construction requesting a modification to the monitoring program when a field condition such as modern disturbance post-dating the previous grading/trenching activities, presence of fossil formations, or when native soils are encountered that may reduce or increase the potential for resources to be present.
4. The archaeological and Native American consultant/monitor shall document field activity via the Consultant Site Visit Record (CSVR). The CSVR's shall be emailed by the CM to the RE the first day of monitoring, the last day of monitoring, monthly (**Notification of Monitoring Completion**), and in the case of ANY discoveries. The RE shall forward copies to MMC.

B. Discovery Notification Process

1. In the event of a discovery, the Archaeological Monitor shall direct the contractor to temporarily divert all soil disturbing activities, including but not limited to digging, trenching, excavating or grading activities in the area of discovery and in the area reasonably suspected to overlay adjacent resources and immediately notify the RE or BI, as appropriate.
2. The Monitor shall immediately notify the PI (unless Monitor is the PI) of the discovery.
3. The PI shall immediately notify MMC by phone of the discovery, and shall also submit written documentation to MMC within 24 hours by email with photos of the resource in context, if possible.
4. No soil shall be exported off-site until a determination can be made regarding the significance of the resource specifically if Native American resources are encountered.

C. Determination of Significance

1. The PI and Native American consultant/monitor, where Native American resources are discovered shall evaluate the significance of the resource. If Human Remains are involved, follow protocol in Section IV below.
 - a. The PI shall immediately notify MMC by phone to discuss significance determination and shall also submit a letter to MMC indicating whether additional mitigation is required.
 - b. If the resource is significant, the PI shall submit an Archaeological Data Recovery Program (ADRP) and obtain written approval of the program from MMC, CM and RE. ADRP and any mitigation must be approved by MMC, RE and/or CM before ground disturbing activities in the area of discovery will be allowed to resume. **Note: If a unique archaeological site is also an historical or tribal cultural resource as defined in CEQA Section, then the limits on the amount(s) that a project applicant may be required to pay to cover mitigation costs as indicated in CEQA Section 21083.2 shall not apply.**

- c. If the resource is not significant, the PI shall submit a letter to MMC indicating that artifacts will be collected, curated, and documented in the Final Monitoring Report. The letter shall also indicate that that no further work is required.

IV. Discovery of Human Remains

If human remains are discovered, work shall halt in that area and no soil shall be exported off-site until a determination can be made regarding the provenance of the human remains; and the following procedures as set forth in CEQA Section 15064.5(e), the California Public Resources Code (Sec. 5097.98) and State Health and Safety Code (Sec. 7050.5) shall be undertaken:

A. Notification

1. Archaeological Monitor shall notify the RE or BI as appropriate, MMC, and the PI, if the Monitor is not qualified as a PI. MMC will notify the appropriate Senior Environmental Planner in the Environmental Analysis Section (EAS) of the Development Services Department to assist with the discovery notification process.
2. The PI shall notify the Medical Examiner after consultation with the RE, either in person or via telephone.

B. Isolate discovery site

1. Work shall be directed away from the location of the discovery and any nearby area reasonably suspected to overlay adjacent human remains until a determination can be made by the Medical Examiner in consultation with the PI concerning the provenience of the remains.
2. The Medical Examiner, in consultation with the PI, will determine the need for a field examination to determine the provenience.
3. If a field examination is not warranted, the Medical Examiner will determine with input from the PI, if the remains are or are most likely to be of Native American origin.

C. If Human Remains **ARE** determined to be Native American

1. The Medical Examiner will notify the Native American Heritage Commission (NAHC) within 24 hours. By law, **ONLY** the Medical Examiner can make this call.
2. NAHC will immediately identify the person or persons determined to be the Most Likely Descendent (MLD) and provide contact information.
3. The MLD will contact the PI within 24 hours or sooner after the Medical Examiner has completed coordination, to begin the consultation process in accordance with CEQA Section 15064.5(e), the California Public Resources and Health & Safety Codes.
4. The MLD will have 48 hours to make recommendations to the property owner or representative, for the treatment or disposition with proper dignity, of the human remains and associated grave goods.
5. Disposition of Native American Human Remains will be determined between the MLD and the PI, and, if:
 - a. The NAHC is unable to identify the MLD, OR the MLD failed to make a recommendation within 48 hours after being notified by the Commission, OR;
 - b. The landowner or authorized representative rejects the recommendation of the MLD and mediation in accordance with PRC 5097.94 (k) by the NAHC fails to provide measures acceptable to the landowner, THEN
 - c. To protect these sites, the landowner shall do one or more of the following:
 - (1) Record the site with the NAHC;
 - (2) Record an open space or conservation easement; or
 - (3) Record a document with the County.
 - d. Upon the discovery of multiple Native American human remains during a ground disturbing land development activity, the landowner may agree that

additional conferral with descendants is necessary to consider culturally appropriate treatment of multiple Native American human remains. Culturally appropriate treatment of such a discovery may be ascertained from review of the site utilizing cultural and archaeological standards. Where the parties are unable to agree on the appropriate treatment measures the human remains and buried with Native American human remains shall be reinterred with appropriate dignity, pursuant to Section 5.c., above.

D. If Human Remains are **NOT** Native American

1. The PI shall contact the Medical Examiner and notify them of the historic era context of the burial.
2. The Medical Examiner will determine the appropriate course of action with the PI and City staff (PRC 5097.98).
3. If the remains are of historic origin, they shall be appropriately removed and conveyed to the San Diego Museum of Man for analysis. The decision for internment of the human remains shall be made in consultation with MMC, EAS, the applicant/landowner, any known descendant group, and the San Diego Museum of Man.

V. Night and/or Weekend Work

A. If night and/or weekend work is included in the contract

1. When night and/or weekend work is included in the contract package, the extent and timing shall be presented and discussed at the precon meeting.
2. The following procedures shall be followed.

a. No Discoveries

In the event that no discoveries were encountered during night and/or weekend work, the PI shall record the information on the CSVR and submit to MMC via email by 8AM of the next business day.

b. Discoveries

All discoveries shall be processed and documented using the existing procedures detailed in Sections III - During Construction, and IV - Discovery of Human Remains. Discovery of human remains shall always be treated as a significant discovery.

c. Potentially Significant Discoveries

If the PI determines that a potentially significant discovery has been made, the procedures detailed under Section III - During Construction and IV - Discovery of Human Remains shall be followed.

d. The PI shall immediately contact the RE and MMC, or by 8AM of the next business day to report and discuss the findings as indicated in Section III-B, unless other specific arrangements have been made.

B. If night and/or weekend work becomes necessary during the course of construction

1. The Construction Manager shall notify the RE, or BI, as appropriate, a minimum of 24 hours before the work is to begin.
2. The RE, or BI, as appropriate, shall notify MMC immediately.

C. All other procedures described above shall apply, as appropriate.

VI. Post Construction

A. Submittal of Draft Monitoring Report

1. The PI shall submit two copies of the Draft Monitoring Report (even if negative), prepared in accordance with the Historical Resources Guidelines (Appendix C/D) which describes the results, analysis, and conclusions of all phases of the Archaeological Monitoring Program (with appropriate graphics) to MMC via the RE for review and approval within 90 days following the completion of monitoring. **It should be noted that if the PI is unable to submit the Draft Monitoring Report within the allotted 90-day timeframe as a result**

of delays with analysis, special study results or other complex issues, a schedule shall be submitted to MMC establishing agreed due dates and the provision for submittal of monthly status reports until this measure can be met.

- a. For significant archaeological resources encountered during monitoring, the Archaeological Data Recovery Program or Pipeline Trenching Discovery Process shall be included in the Draft Monitoring Report.
 - b. Recording Sites with State of California Department of Parks and Recreation The PI shall be responsible for recording (on the appropriate State of California Department of Park and Recreation forms-DPR 523 A/B) any significant or potentially significant resources encountered during the Archaeological Monitoring Program in accordance with the City's Historical Resources Guidelines, and submittal of such forms to the South Coastal Information Center with the Final Monitoring Report.
2. MMC shall return the Draft Monitoring Report to the PI via the RE for revision or, for preparation of the Final Report.
 3. The PI shall submit revised Draft Monitoring Report to MMC via the RE for approval.
 4. MMC shall provide written verification to the PI of the approved report.
 5. MMC shall notify the RE or BI, as appropriate, of receipt of all Draft Monitoring Report submittals and approvals.
- B. Handling of Artifacts
1. The PI shall be responsible for ensuring that all cultural remains collected are cleaned and catalogued
 2. The PI shall be responsible for ensuring that all artifacts are analyzed to identify function and chronology as they relate to the history of the area; that faunal material is identified as to species; and that specialty studies are completed, as appropriate.
- C. Curation of artifacts: Accession Agreement and Acceptance Verification
1. The PI shall be responsible for ensuring that all artifacts associated with the survey, testing and/or data recovery for this project are permanently curated with an appropriate institution. This shall be completed in consultation with MMC and the Native American representative, as applicable.
 2. When applicable to the situation, the PI shall include written verification from the Native American consultant/monitor indicating that Native American resources were treated in accordance with state law and/or applicable agreements. If the resources were reinterred, verification shall be provided to show what protective measures were taken to ensure no further disturbance occurs in accordance with Section IV – Discovery of Human Remains, Subsection 5.
 3. The PI shall submit the Accession Agreement and catalogue record(s) to the RE or BI, as appropriate for donor signature with a copy submitted to MMC.
- D. Final Monitoring Report(s)
1. The PI shall submit one copy of the approved Final Monitoring Report to the RE or BI as appropriate, and one copy to MMC (even if negative), within 90 days after notification from MMC of the approved report.
 2. The RE shall, in no case, issue the Notice of Completion and/or release of the Performance Bond for grading until receiving a copy of the approved Final Monitoring Report from MMC which includes the Acceptance Verification from the curation institution.

II. BIOLOGICAL RESOURCES

Resource Protection During Construction and Habitat Mitigation

BIO-1: Prior to the issuance of any grading permit, the City Manager (or appointed designee) shall verify that the following project requirements are shown on the construction plans:

I. **Prior to the Start of Construction**

- A. **Biologist Verification:** The owner/permittee shall provide a letter to the City's Mitigation Monitoring Coordination (MMC) section stating that a Project Biologist (Qualified Biologist) as defined in the City of San Diego's Biology Guidelines (2012), has been retained to implement the project's biological monitoring program. The letter shall include the names and contact information of all persons involved in the biological monitoring of the project.
- B. **Preconstruction Meeting:** The Qualified Biologist shall attend the preconstruction meeting, discuss the project's biological monitoring program, and arrange to perform any follow up mitigation measures and reporting including site -specific monitoring, restoration or revegetation, and additional fauna/flora surveys/salvage.
- C. **Biological Documents:** The Qualified Biologist shall submit all required documentation to MMC verifying that any special mitigation reports including but not limited to, maps, plans, surveys, survey timelines, or buffers are complete or scheduled per City Biology Guidelines, MSCP, ESL Regulation project permit conditions; CEQA; endangered species acts (ESAs); and/or other local, state or federal requirements.
- D. **BCME:** The Qualified Biologist shall present a Biological Construction Mitigation/Monitoring Exhibit (BCME), which includes the biological documents in C above. In addition, include: restoration/revegetation plans, plant salvage/relocation requirements (e.g., coastal cactus wren plant salvage, burrowing owl exclusions, etc.), avian or other wildlife surveys/survey schedules (including nesting surveys for yellow-breasted chat, yellow warbler, and Cooper's hawk, least Bell's vireo), timing of surveys, wetland buffers, avian construction avoidance areas/noise buffers/ barriers, other impact avoidance areas, and any subsequent requirements determined by the Qualified Biologist and the City ADD/MMC. The BCME shall include a site plan, written and graphic depiction of the project's biological mitigation/monitoring program, and a schedule. The BCME shall be approved by MMC and referenced in the construction documents.
- E. **Avian Protection Requirements:** To avoid any direct impacts to sensitive bird species such as yellow-breasted chat, yellow warbler, Cooper's hawk, and least Bell's vireo removal of habitat that supports active nests in the proposed area of

disturbance should occur outside of the breeding season for these species (February 1 to September 15). If removal of habitat in the proposed area of disturbance must: occur during the breeding season, the Qualified Biologist shall conduct a pre-construction survey to determine the presence or absence of the yellow-breasted chat, yellow warbler, and Cooper's hawk, on the proposed area of disturbance. The preconstruction survey shall be conducted within 10 calendar days prior to the start of construction activities (including removal of vegetation). The applicant shall submit the results of the preconstruction survey to City DSD for review and approval prior to initiating any construction activities. If nesting birds are detected, a letter report or mitigation plan in conformance with the City's Biology Guidelines and applicable State and Federal Law (i.e., appropriate follow up surveys, monitoring schedules, construction and noise barriers/buffers, etc.) shall be prepared and include proposed measures to be implemented to ensure that take of birds or eggs or disturbance of breeding activities is avoided. The report or mitigation plan shall be submitted to the City for review and approval and implemented to the satisfaction of the City. The City's MMC Section or RE, and Biologist shall verify and approve that all measures identified in the report or mitigation plan are in place prior to and/or during construction.

- F. **Resource Delineation:** Prior to construction activities, the Qualified Biologist shall supervise the placement of orange construction fencing or equivalent along the limits of disturbance adjacent to sensitive biological habitats and verify compliance with any other project conditions as shown on the BCME. This phase shall include lagging plant specimens and delimiting buffers to protect sensitive biological resources (e.g., habitats/flora & fauna species, including nesting yellow-breasted chat, yellow warbler, Cooper's hawk, and least Bell's vireo) during construction. Appropriate steps/care should be taken to minimize attraction of nest predators to the site.
- G. **Education:** Prior to commencement of construction activities, the Qualified Biologist shall meet with the owner/permittee or designee and the construction crew and conduct an on-site educational session regarding the need to avoid impacts outside of the approved construction area and to protect sensitive flora and fauna (e.g., explain the avian and wetland buffers, flag system for removal of invasive species or retention of sensitive plants, and clarify acceptable access routes/methods and staging area, etc.).

II. **During Construction**

- A. **Monitoring:** All construction (including access/staging area) shall be restricted to areas previously identified, proposed for development/staging, or previously disturbed as shown on "Exhibit A" and/or the BCME. The Qualified Biologist shall monitor construction activities as needed to ensure that construction activities do not encroach into biologically sensitive areas, or cause other similar damage, and that the work plan has been amended to accommodate any sensitive species

located during the pre-construction surveys. In addition, the Qualified Biologist shall document field activity via the Consultant Site Visit Record (CSV). The CSV shall be e-mailed to MMC on the 1st day of monitoring, the 1st week of each month, the last day of monitoring, and immediately in the case of any undocumented condition or discovery.

- B. Subsequent Resource Identification** - The Qualified Biologist shall note/act to prevent any new disturbances to habitat, flora, and/or fauna onsite (e.g., flag plant specimens for avoidance during access, etc.). If active nests or other previously unknown sensitive resources are detected, all project activities that directly impact the resource shall be delayed until species specific local, state or federal regulations have been determined and applied by the Qualified Biologist.

III. Post Construction Measures

- A.** In the event that impacts exceed previously allowed amounts, additional impacts shall be mitigated in accordance with City Biology Guidelines, ESL and MSCP, CEQA, and other applicable local, state and federal law. The Qualified Biologist shall submit a final BCME/report to the satisfaction of the City ADD/MMC within 30 days of construction completion.

Biological Resources (Habitat Mitigation - Sensitive Upland)

- BIO-2a:** Prior to the issuance of a Notice to Proceed or any permits, including but not limited to, the first Grading Permit, Demolition/Development Plans/Permits, and Building Plans/Permits, whichever is applicable, the Owner/Permittee shall mitigate the project impacts to upland habitat in accordance with the City's Biology Guidelines (2012). Accordingly, the Owner/Permittee shall mitigate for project impacts to 0.98-acres of Tier II habitat (Disturbed Diegan coastal sage scrub/Baccharis-dominated scrub) at a 1.5:1 mitigation ratio with 0.98-acres of Tier II or better habitat inside the MHPA and 0.07-acre of non-native grassland (Tier IIIB) at a 1:1 ratio. This shall be achieved through on-site conservation of 5.32 acres of upland habitat into the MHPA.
- BIO-2b:** Prior to issuance of a grading permit, the owner/permittee shall provide an Upland Mitigation Bond to the satisfaction of the City ED/MMC/MSCP to ensure the sensitive upland mitigation will be completed. The Upland Mitigation Bond shall be released upon the achievement of BIO-4, restoration/preservation identified above, and the following success criteria (as identified in the Conceptual Wetlands Mitigation Plan [Dudek 2009]) within the 100-foot wetlands buffer area at the end of five years to the satisfaction of MMC, MSCP, ED; and
- BIO-2c:** Prior to issuance of a grading permit, the owner/permittee shall dedicate to the City of San Diego, interest in property necessary to maintain the land in its existing condition in perpetuity, a total of 5.32-acres of on-site upland (Tier IIIB or better) and wetland habitat into the City's MHPA through recordation and acceptance of a conservation easement.

Biological Resources (Habitat Mitigation - Sensitive Wetland Habitat)

BIO-3a: Prior to the issuance of a Notice to Proceed or any permits, including but not limited to, the first Grading Permit, Demolition/Development Plans/Permits, and Building Plans/Permits, whichever is applicable, the Owner/Permittee shall mitigate the project impacts to City wetlands in accordance with the City's Biology Guidelines. Accordingly, the Owner/Permittee shall mitigate for project impacts to 0.02 acre (southern willow scrub) at a 3:1 mitigation ratio. Accordingly, mitigation for City wetland impacts shall include a 2:1 restoration/enhancement component. This shall be achieved on-site in accordance with the Conceptual Wetlands Mitigation Plan prepared by Dudek (April 2009):

- Enhancement of .042-acre of Southern Willow Scrub
- 1.53- acre of Wetland Buffer Zone Seeding - Coastal Sage Scrub
- 0.48- acre weed removal

BIO-3b: Prior to issuance of a grading permit, the applicant shall provide a Wetland Mitigation Bond to the satisfaction of the City ED/MMC/MSCP to ensure this mitigation will be completed. The Wetland Mitigation Bond shall be released upon the achievement of the wetland enhancement/restoration, and the success criteria (as identified in the Conceptual Wetlands Mitigation Plan [Dudek 2009]): to achieve success criteria within the 100-foot wetlands buffer area at the end of five years.

Biological Resources (Long-term Management of Mitigation Land)

BIO-4a: Prior to the issuance of a Notice to Proceed or any permits, including but not limited to, the first Grading Permit, Demolition/Development Plans/Permits, and Building Plans/Permits, whichever is applicable, the applicant shall provide an endowment to adequately fund the estimated annual costs associated with the long-term management tasks identified in the Conceptual Wetlands Mitigation Plan [Dudek 2009]. These tasks consist of annual sensitive vegetation monitoring, sensitive species monitoring, exotic species control, public awareness, trespass monitoring and management, trash monitoring and management, and reporting and administration. The endowment amount shall be calculated via a Property Analysis Record (PAR) analysis completed by the qualified habitat management entity (such as the San Diego Foundation), to the satisfaction of the City ED/MMC/MSCP.

BIO-4b: Prior to the issuance of a Notice to Proceed or any permits, including but not limited to, the first Grading Permit, Demolition/Development Plans/Permits, and Building Plans/Permits, whichever is applicable, the applicant shall provide documentation of an executed agreement with a qualified habitat management entity that provides for the implementation of the long-term management of the wetland and upland mitigation areas in perpetuity in accordance with the Conceptual Wetlands Mitigation Plan [Dudek 2009] to the satisfaction of MMC.

BIO-4c: Prior to the issuance of a Notice to Proceed or any permits, including but not limited to, the first Grading Permit, Demolition/Development Plans/Permits, and Building Plans/Permits, whichever is applicable, a covenant of easement shall be provided over the MHPA area to the satisfaction of MSCP. The covenant of easement shall specifically prohibit activities in the wetland and upland mitigation areas that will affect biological value, as follows (as listed in the Biology Letter Report (REC 2018) and Conceptual Wetlands Mitigation Plan [Dudek 2009]):

- Herbicide types, rodenticides, pesticides, incompatible fire protection activities, and any, and all other uses which may adversely affect conservation of watersheds;
- Use of off-road vehicles;
- Grazing or surface entry for exploration or extraction of minerals;
- Erecting of any building, billboard, or sign (except informational signs associated with the mitigation site);
- Depositing of soil, trash, ashes, garbage, waste, bio-solids, or any other material; (soil deposition in association with an approved restoration program is allowed);
- Excavating, dredging, or removing of loam, gravel, soil, rock, sand, or other material; (excavation or moving of soil, gravel, loam, rock, sand or other material in association with an approved restoration program is allowed);
- Otherwise altering the general topography of the conserved area, including the building of roads; and
- Removing, destroying, or cutting of trees, shrubs or other vegetation other than the non-native plant removal or brush management activities. Alterations in association with an approved restoration program are allowed.

Biological Resources (Restoration/Revegetation Plan and Construction Monitoring)

BIO-4d: Prior to the issuance of a Notice to Proceed (NTP) or any construction permits, including but not limited to, the first Grading Permit, Demolition Plans/Permits and Building Plans/Permits the City’s Environmental Designee of the City's Land Development Review Division (LDR) shall verify that the following statement is shown on the grading and/or construction plans as a note under the heading *Environmental Requirements:* "**The 10325 Roselle Street Project is subject to Mitigation, Monitoring and Reporting Program and shall conform to the mitigation conditions as contained in the Mitigated Negative Declaration No. 150566 / State Clearinghouse No. Pending**

BIO-4e: Prior to Permit Issuance

A. Land Development Review (LDR) Plan Check

1. Prior to NTP or issuance for any construction permits, including but not limited to, the first Grading Permit, Demolition Plans/Permits and Building Plans/Permits, whichever is applicable, the ADD environmental designee shall verify that the requirements for the revegetation/restoration plans and specifications, including mitigation of direct impacts to upland and wetland habitats have been shown and noted on the appropriate landscape construction documents. The landscape construction documents and specifications must be found to be in conformance with the Conceptual Wetlands Restoration Plan prepared by Dudek 2019, the requirements of which are summarized above.

B. Revegetation/Restoration Plan(s) and Specifications

1. Landscape Construction Documents (LCD) shall be prepared on D-sheets and submitted to the City of San Diego Development Services Department, Landscape Architecture Section (LAS) for review and approval. LAS shall consult with Mitigation Monitoring Coordination (MMC) and obtain concurrence prior to approval of LCD. The LCD shall consist of revegetation/restoration, planting, irrigation and erosion control plans; including all required graphics, notes, details, specifications, letters, and reports as outlined below.
2. Landscape Revegetation/Restoration Planting and Irrigation Plans shall be prepared in accordance with the San Diego Land Development Code (LDC) Chapter 14, Article 2, Division 4, the LDC Landscape Standards submittal requirements, and Attachment “B” (General Outline for Revegetation/Restoration Plans) of the City of San Diego’s LDC Biology Guidelines (July 2002). The Principal Qualified Biologist (PQB) shall identify and

adequately document all pertinent information concerning the revegetation/restoration goals and requirements, such as but not limited to, plant/seed palettes, timing of installation, plant installation specifications, method of watering, protection of adjacent habitat, erosion and sediment control, performance/success criteria, inspection schedule by City staff, document submittals, reporting schedule, etc. The LCD shall also include comprehensive graphics and notes addressing the ongoing maintenance requirements (after final acceptance by the City).

3. The Revegetation Installation Contractor (RIC), Revegetation Maintenance Contractor (RMC), Construction Manager (CM) and Grading Contractor (GC), where applicable shall be responsible to insure that for all grading and contouring, clearing and grubbing, installation of plant materials, and any necessary maintenance activities or remedial actions required during installation and the 120 day plant establishment period are done per approved LCD. The following procedures at a minimum, but not limited to, shall be performed:
 - a. The RMC shall be responsible for the maintenance of the upland/wetland mitigation area for a minimum period of 120 days. Maintenance visits shall be conducted on a weekly basis throughout the plant establishment period.
 - b. At the end of the 120 day period the PQB shall review the mitigation area to assess the completion of the short-term plant establishment period and submit a report for approval by MMC.
 - c. MMC will provide approval in writing to begin the five year long-term establishment/maintenance and monitoring program.
 - d. Existing indigenous/native species shall not be pruned, thinned or cleared in the revegetation/mitigation area.
 - e. The revegetation site shall not be fertilized.
 - f. The RIC is responsible for reseeding (if applicable) if weeds are not removed, within one week of written recommendation by the PQB.
 - g. Weed control measures shall include the following: (1) hand removal, (2) cutting, with power equipment, and (3) chemical control. Hand removal of weeds is the most desirable method of control and will be used wherever possible.
 - h. Damaged areas shall be repaired immediately by the RIC/RMC. Insect infestations, plant diseases, herbivory, and other pest problems will be closely monitored throughout the five-year maintenance period. Protective mechanisms such as metal wire netting shall be used as necessary. Diseased and infected plants shall be immediately disposed of off-site in a legally-acceptable manner at the discretion of the PQB or Qualified Biological Monitor (QBM) (City approved). Where possible, biological controls will be used instead of pesticides and herbicides.
4. If a Brush Management Program is required the revegetation/restoration plan shall show the dimensions of each brush management zone and notes shall be provided describing the restrictions on planting and maintenance and identify that the area is impact neutral and shall not be used for habitat mitigation/credit purposes.

C. Letters of Qualification Have Been Submitted to ADD

1. The applicant shall submit, for approval, a letter verifying the qualifications of the biological professional to MMC. This letter shall identify the PQB, Principal Restoration Specialist (PRS), and QBM, where applicable, and the names of all other persons involved in the implementation of the revegetation/restoration plan and biological monitoring program, as they are defined in the City of San Diego Biological Review References. Resumes and the biology worksheet should be updated annually.

2. MMC will provide a letter to the applicant confirming the qualifications of the PQB/PRS/QBM and all City Approved persons involved in the revegetation/restoration plan and biological monitoring of the project.
3. Prior to the start of work, the applicant must obtain approval from MMC for any personnel changes associated with the revegetation/restoration plan and biological monitoring of the project.
4. PQB must also submit evidence to MMC that the PQB/QBM has completed Storm Water Pollution Prevention Program (SWPPP) training.

Prior to Start of Construction

- A. PQB/PRS Shall Attend Preconstruction (Precon) Meetings
 1. Prior to beginning any work that requires monitoring:
 - a. The owner/permittee or their authorized representative shall arrange and perform a Precon Meeting that shall include the PQB or PRS, Construction Manager (CM) and/or Grading Contractor (GC), Landscape Architect (LA), Revegetation Installation Contractor (RIC), Revegetation Maintenance Contractor (RMC), Resident Engineer (RE), Building Inspector (BI), if appropriate, and MMC.
 - b. The PQB shall also attend any other grading/excavation related Precon Meetings to make comments and/or suggestions concerning the revegetation/restoration plan(s) and specifications with the RIC, CM and/or GC.
 - c. If the PQB is unable to attend the Precon Meeting, the owner shall schedule a focused Precon Meeting with MMC, PQB/PRS, CM, BI, LA, RIC, RMC, RE and/or BI, if appropriate, prior to the start of any work associated with the revegetation/ restoration phase of the project, including site grading preparation.
 2. Where Revegetation/Restoration Work Will Occur
 - a. Prior to the start of any work, the PQB/PRS shall also submit a revegetation/restoration monitoring exhibit (RRME) based on the appropriate reduced LCD (reduced to 11"x 17" format) to MMC, and the RE, identifying the areas to be revegetated/restored including the delineation of the limits of any disturbance/grading and any excavation.
 - b. PQB shall coordinate with the construction superintendent to identify appropriate Best Management Practices (BMP's) on the RRME.
 3. When Biological Monitoring Will Occur
 - a. Prior to the start of any work, the PQB/PRS shall also submit a monitoring procedures schedule to MMC and the RE indicating when and where biological monitoring and related activities will occur.
 4. PQB Shall Contact MMC to Request Modification
 - a. The PQB may submit a detailed letter to MMC prior to the start of work or during construction requesting a modification to the revegetation/restoration plans and specifications. This request shall be based on relevant information (such as other sensitive species not listed by federal and/or state agencies and/or not covered by the MSCP and to which any impacts may be considered significant under CEQA) which may reduce or increase the potential for biological resources to be present.

During Construction

- A. PQB or QBM Present During Construction/Grading/Planting
 1. The PQB or QBM shall be present full-time during construction activities including but not limited to, site preparation, clearing, grading, excavation, landscape establishment in association with construction and/or grading activities which could result in impacts to sensitive biological resources as identified in the LCD and on the RRME. **The RIC and/or QBM are responsible for notifying the PQB/PRS of changes to any approved construction plans,**

procedures, and/or activities. The PQB/PRS is responsible to notify the CM, LA, RE, BI and MMC of the changes.

2. The PQB or QBM shall document field activity via the Consultant Site Visit Record Forms (CSVSR). The CSVSR's shall be faxed by the CM the first day of monitoring, the last day of monitoring, monthly, and in the event that there is a deviation from conditions identified within the LCD and/or biological monitoring program. The RE shall forward copies to MMC.
 3. The PQB or QBM shall be responsible for maintaining and submitting the CSVSR at the time that CM responsibilities end (i.e., upon the completion of construction activity other than that of associated with biology).
 4. All construction activities (including staging areas) shall be restricted to the development areas as shown on the LCD. The PQB/PRS or QBM staff shall monitor construction activities as needed, with MMC concurrence on method and schedule. This is to ensure that construction activities do not encroach into biologically sensitive areas beyond the limits of disturbance as shown on the approved LCD.
 5. The PQB or QBM shall supervise the placement of orange construction fencing or City approved equivalent, along the limits of potential disturbance adjacent to (or at the edge of) all sensitive habitats as shown on the approved LCD.
 6. The PQB shall provide a letter to MMC that limits of potential disturbance has been surveyed, staked and that the construction fencing is installed properly
 7. The PQB or QBM shall oversee implementation of BMP's, such as gravel bags, straw logs, silt fences or equivalent erosion control measures, as needed to ensure prevention of any significant sediment transport. In addition, the PQB/QBM shall be responsible to verify the removal of all temporary construction BMP's upon completion of construction activities. Removal of temporary construction BMP's shall be verified in writing on the final construction phase CSVSR.
 8. PQB shall verify in writing on the CSVSR's that no trash stockpiling or oil dumping, fueling of equipment, storage of hazardous wastes or construction equipment/material, parking or other construction related activities shall occur adjacent to sensitive habitat. These activities shall occur only within the designated staging area located outside the area defined as biological sensitive area.
 9. The long-term establishment inspection and reporting schedule per LCD must all be approved by MMC prior to the issuance of the Notice of Completion (NOC) or any bond release.
- B. Disturbance/Discovery Notification Process
1. If unauthorized disturbances occurs or sensitive biological resources are discovered that were not previously identified on the LCD and/or RRME, the PQB or QBM shall direct the contractor to temporarily divert construction in the area of disturbance or discovery and immediately notify the RE or BI, as appropriate.
 2. The PQB shall also immediately notify MMC by telephone of the disturbance and report the nature and extent of the disturbance and recommend the method of additional protection, such as fencing and appropriate Best Management Practices (BMP's). After obtaining concurrence with MMC and the RE, PQB and CM shall install the approved protection and agreement on BMP's.
 3. The PQB shall also submit written documentation of the disturbance to MMC within 24 hours by fax or email with photos of the resource in context (e.g., show adjacent vegetation).

C. Determination of Significance

1. The PQB shall evaluate the significance of disturbance and/or discovered biological resource and provide a detailed analysis and recommendation in a letter report with the appropriate photo documentation to MMC to obtain concurrence and formulate a plan of action which can include fines, fees, and supplemental mitigation costs.
2. MMC shall review this letter report and provide the RE with MMC's recommendations and procedures.

Post Construction

A. Mitigation Monitoring and Reporting Period

1. Five-Year Mitigation Establishment/Maintenance Period
 - a. The RMC shall be retained to complete maintenance monitoring activities throughout the five-year mitigation monitoring period.
 - b. Maintenance visits will be conducted twice per month for the first six months, once per month for the remainder of the first year, and quarterly thereafter.
 - c. Maintenance activities will include all items described in the LCD.
 - d. Plant replacement will be conducted as recommended by the PQB (note: plants shall be increased in container size relative to the time of initial installation or establishment or maintenance period may be extended to the satisfaction of MMC).
2. Five-Year Biological Monitoring
 - a. All biological monitoring and reporting shall be conducted by a PQB or QBM, as appropriate, consistent with the LCD.
 - b. Monitoring shall involve both qualitative horticultural monitoring and quantitative monitoring (i.e., performance/success criteria). Horticultural monitoring shall focus on soil conditions (e.g., moisture and fertility), container plant health, seed germination rates, presence of native and non-native (e.g., invasive exotic) species, any significant disease or pest problems, irrigation repair and scheduling, trash removal, illegal trespass, and any erosion problems.
 - c. After plant installation is complete, qualitative monitoring surveys will occur monthly during year one and quarterly during years two through five.
 - d. Upon the completion of the 120-days short-term plant establishment period, quantitative monitoring surveys shall be conducted at 0, 6, 12, 24, 36, 48 and 60 months by the PQB or QBM. The revegetation/restoration effort shall be quantitatively evaluated once per year (in spring) during years three through five, to determine compliance with the performance standards identified on the LCD. All plant material must have survived without supplemental irrigation for the last two years.
 - e. Quantitative monitoring shall include the use of fixed transects and photo points to determine the vegetative cover within the revegetated habitat. Collection of fixed transect data within the revegetation/restoration site shall result in the calculation of percent cover for each plant species present, percent cover of target vegetation, tree height and diameter at breast height (if applicable) and percent cover of non-native/non-invasive vegetation. Container plants will also be counted to determine percent survivorship. The data will be used determine attainment of performance/success criteria identified within the LCD.
 - f. Biological monitoring requirements may be reduced if, before the end of the fifth year, the revegetation meets the fifth-year criteria and the irrigation has been terminated for a period of the last two years.

- g. The PQB or QBM shall oversee implementation of post-construction BMP's, such as gravel bags, straw logs, silt fences or equivalent erosion control measure, as needed to ensure prevention of any significant sediment transport. In addition, the PBQ/QBM shall be responsible to verify the removal of all temporary post-construction BMP's upon completion of construction activities. Removal of temporary post-construction BMPs shall be verified in writing on the final post-construction phase CSV.

C. Submittal of Draft Monitoring Report

1. A draft monitoring letter report shall be prepared to document the completion of the 120-day plant establishment period. The report shall include discussion on weed control, horticultural treatments (pruning, mulching, and disease control), erosion control, trash/debris removal, replacement planting/reseeding, site protection/signage, pest management, vandalism, and irrigation maintenance. The revegetation/restoration effort shall be visually assessed at the end of 120 day period to determine mortality of individuals.
2. The PQB shall submit two copies of the Draft Monitoring Report which describes the results, analysis, and conclusions of all phases of the Biological Monitoring and Reporting Program (with appropriate graphics) to MMC for review and approval within 30 days following the completion of monitoring. Monitoring reports shall be prepared on an annual basis for a period of five years. Site progress reports shall be prepared by the PQB following each site visit and provided to the owner, RMC and RIC. Site progress reports shall review maintenance activities, qualitative and quantitative (when appropriate) monitoring results including progress of the revegetation relative to the performance/success criteria, and the need for any remedial measures.
3. Draft annual reports (three copies) summarizing the results of each progress report including quantitative monitoring results and photographs taken from permanent viewpoints shall be submitted to MMC for review and approval within 30 days following the completion of monitoring.
4. MMC shall return the Draft Monitoring Report to the PQB for revision or, for preparation of each report.
5. The PQB shall submit revised Monitoring Report to MMC (with a copy to RE) for approval within 30 days.
6. MMC will provide written acceptance of the PQB and RE of the approved report.

D. Final Monitoring Reports(s)

1. PQB shall prepare a Final Monitoring upon achievement of the fifth-year performance/success criteria and completion of the five-year maintenance period.
 - a. This report may occur before the end of the fifth year if the revegetation meets the fifth-year performance /success criteria and the irrigation has been terminated for a period of the last two years.
 - b. The Final Monitoring report shall be submitted to MMC for evaluation of the success of the mitigation effort and final acceptance. A request for a pre-final inspection shall be submitted at this time, MMC will schedule after review of report.
 - c. If at the end of the five years any of the revegetated area fails to meet the project's final success standards, the applicant must consult with MMC. This consultation shall take place to determine whether the revegetation effort is acceptable. The applicant understands that failure of any significant portion of the revegetation/restoration area may result in a requirement to replace or renegotiate that portion of the site and/or extend the monitoring and establishment/maintenance period until all success standards are met.

VI. PUBLIC REVIEW DISTRIBUTION:

Draft copies or notice of this Mitigated Negative Declaration were distributed to:

Federal

MCAS Miramar Air Station (13)
U.S. Environmental Protection Agency (19)
U.S. Fish and Wildlife Service (23)
U.S. Army Corps of Engineers (26)

State of California

Caltrans District 11 (31)
California Department of Fish and Wildlife (32)
CAL EPA (37A)
Department of Toxic Substance Control (39)
California State Parks-Southern Service Center (40A)
Resources Agency (43)
Regional Water Quality Control Board (44)
Department of Water Resources (45)
State Clearinghouse (46)
Coastal Commission (47)
Department of Transportation Aviation Environmental Specialist (51A)
Native American Heritage Commission (56)

City of San Diego

Mayor's Office
Councilmember Barbara Bry - Council District 1
Office of the City Attorney
Planning Department
Development Services Department
Transportation & Storm Water Department
Public Works Department
Public Utilities Department
Downtown Main Library - Government Documents (MS 17)
Mira Mesa Branch Library (MS 17)
North University Branch Library (MS 17)

Other Groups and Individuals

Torrey Pines Community Planning Board (469)
Torrey Pines Association (472)
Friends of Los Penasquitos Canyon Preserve (477)
California Coastal Commission (47)
San Diego County Regional Airport Authority (110)
San Diego Gas and Electric (114)
San Diego Transit Corporation (112)
San Diego Association of Governments (108)
Sierra Club (165)
San Diego Canyonlands (165A)
San Diego Audubon Society (167)
Jim Peugh (167A)
California Native Plant Society (170)
San Diego Coastkeeper (173)
Endangered Habitat League (182 & 182A)
Carmen Lucas (206)

South Coastal Information Center (210)
San Diego Archaeological Center (212)
San Diego History Center (211)
Save our Heritage Organisation (214)
Ron Christman (215)
Clint Linton (215b)
Frank Brown (216)
San Diego County Archaeological Society (218)
Kumeyaay Cultural Heritage Preservation (223)
Kumeyaay Cultural Repatriation Society (225)
Native American Distribution (225 A-S)
 Barona Group of Capitan Grande Band of Mission Indians (225A)
 Campo Band of Mission Indians (225B)
 Ewiaapaayp Band of Mission Indians (225C)
 Inaja Band of Mission Indians (225D)
 Jamul Indian Village (225E)
 La Posta Band of Mission Indians (225F)
 Manzanita Band of Mission Indians (225G)
 Sycuan Band of Mission Indians (225H)
 Viejas Group of Capitan Grande Band of Mission Indians (225I)
 Mesa Grande Band of Mission Indians (225J)
 San Pasqual Band of Mission Indians (225K)
 Ipai Nation of Santa Ysabel (225L)
 La Jolla Band of Mission Indians (225M)
 Pala Band of Mission Indians (225N)
 Pauma Band of Mission Indians (225O)
 Pechanga Band of Mission Indians (225P)
 Rincon Band of Luiseno Indians (225Q)
 San Luis Rey Band of Luiseno Indians (225R)
 Los Coyotes Band of Mission Indians (225S)
CLL-Roselle, LLC (Applicant)
Stevens-Cresto Engineering, Inc. (Consultant)
Helix Environmental Planning (Consultant)
REC Consultants, Inc (Consultant)

VII. RESULTS OF PUBLIC REVIEW:

- () No comments were received during the public input period.
- () Comments were received but did not address the draft Mitigated Negative Declaration finding or the accuracy/completeness of the Initial Study. No response is necessary. The letters are attached.
- () Comments addressing the findings of the draft Mitigated Negative Declaration and/or accuracy or completeness of the Initial Study were received during the public input period. The letters and responses follow.

Copies of the draft Mitigated Negative Declaration, the Mitigation, Monitoring and Reporting Program and any Initial Study material are available in the office of the Planning Department for review, or for purchase at the cost of reproduction.



Myra Herrmann, Senior Planner
Planning Department

March 22, 2019
Date of Draft Report

Date of Final Report

Attachments:

- Figure 1 – Location Map
- Figure 2 – Project Location Aerial
- Figure 3 – Biological Resources
- Figures 4-10 – Site Plan Set

Initial Study Checklist

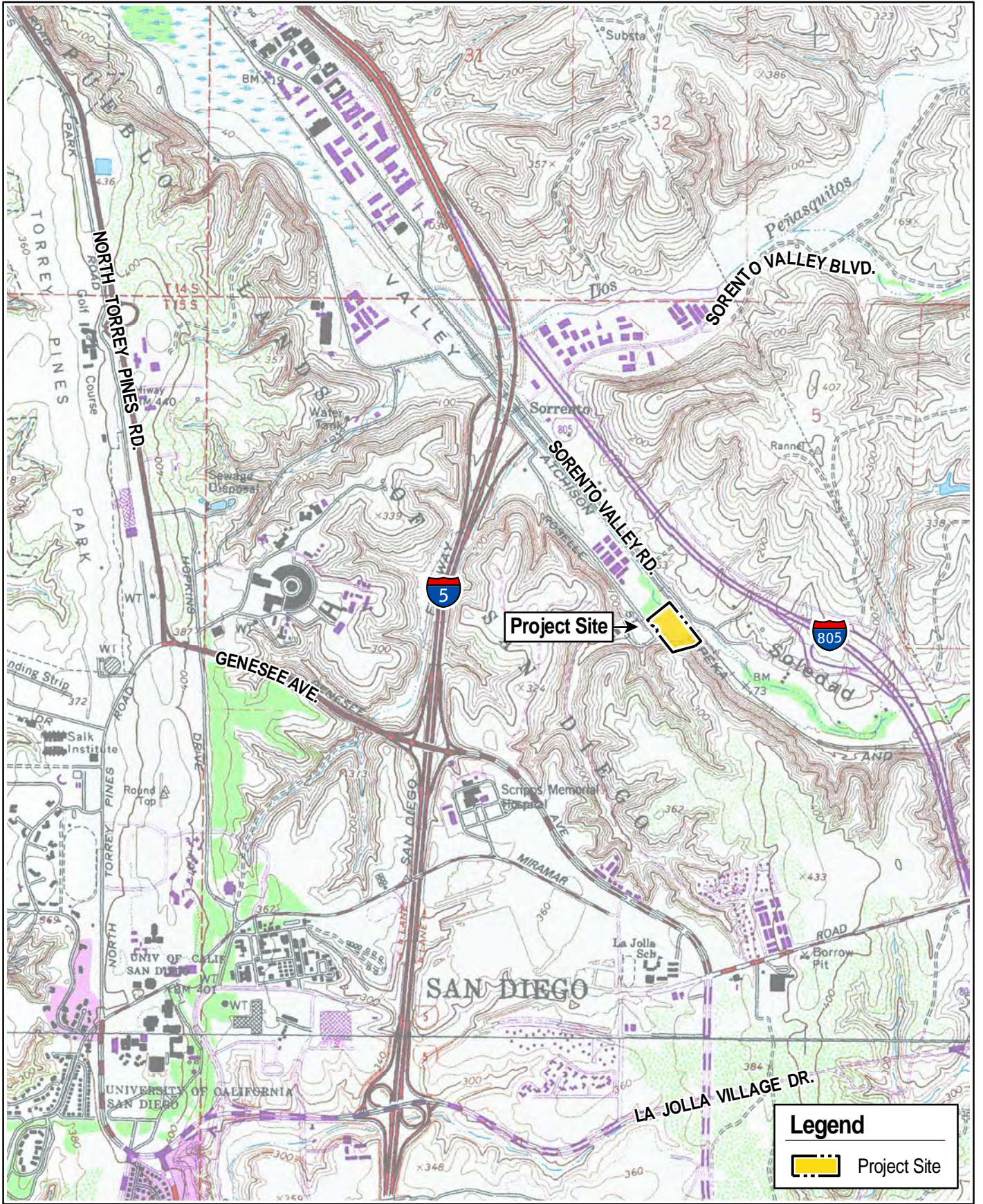

T:\Project_Data\Roselle_Street\Final_Maps\BTR-Update_July2018\ROS_Fig-02_VicinityMap_070218.mxd

Vicinity Map

10325 ROSELLE STREET

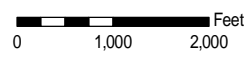

FIGURE 1

Source: Esri Basemap

July 2018



T:\Project_Data\Roselle_Street\Final_Maps\BTR-Update_July2018\ROS_Fig-03_AerialMap_070218.mxd



ROSELLE STREET

SITE DEVELOPMENT PERMIT / COASTAL DEVELOPMENT PERMIT NEIGHBORHOOD DEVELOPMENT PERMIT

* DEVELOPMENT SUMMARY *

- PROJECT PROPOSES A FENCED, GRADED PAD, AND OPEN SPACE ON A 7.04-ACRE LOT IN THE TORREY PINES COMMUNITY. THE SITE PREVIOUSLY WAS USED FOR A CHILDREN'S DAY CAMP. THE PROJECT LIES WITHIN BOTH THE APPEALABLE AND NON-APPEALABLE AREA OF THE COASTAL ZONE. ALL PROPOSED DEVELOPMENT IS WITHIN THE NON-APPEALABLE AREA AND WITHIN EXISTING DISTURBED AREAS. NO VARIANCES ARE REQUESTED. THE PROJECT REQUIRES THE FOLLOWING DISCRETIONARY APPROVALS:
 - ENVIRONMENTALLY SENSITIVE LANDS SITE DEVELOPMENT PERMIT
 - COASTAL DEVELOPMENT PERMIT
 - NEIGHBORHOOD DEVELOPMENT PERMIT
- PROJECT TEAM IS LISTED BELOW IN THE TITLE BLOCK
- LEGAL DESCRIPTION: LOT "B" AND THE SOUTHEASTERLY 65 FEET OF LOT "A" OF ACRES LOT 33 OF TOWN OF SORRENTO, IN THE CITY OF SAN DIEGO, COUNTY OF SAN DIEGO, STATE OF CALIFORNIA, ACCORDING TO MAP NOS. 362 AND 483, FILED IN THE OFFICE OF THE COUNTY RECORDER OF SAN DIEGO COUNTY, SEPTEMBER 30, 1887, AND FEBRUARY 9, 1888, RESPECTIVELY.

APN: 340-080-40
- OWNER: CLL-ROSELLE LLC
3565 RIVERA DRIVE
SAN DIEGO, CA 92109
CONTACT: CHRIS LOUGHRIDGE
- TYPE OF CONSTRUCTION: N/A
OCCUPANCY CLASSIFICATION: N/A
- ZONING: IL-3-1 (INDUSTRIAL-LIGHT) - NO CHANGE PROPOSED
COASTAL - APPEALABLE AND NON-APPEALABLE AREA 1
AIRPORT INFLUENCE ZONE (MCAS-MIRAMAR)
FAA PART 77 NOTIFICATION AREA (MCAS-MIRAMAR)
AIRPORT ENVIRONS OVERLAY ZONE (60-CNEL)
ACCIDENT POTENTIAL ZONE 2
- LAND USE DESIGNATION: TORREY PINES COMMUNITY PLAN DESIGNATION:
INDUSTRIAL AND OPEN SPACE - NO CHANGE PROPOSED
- GROSS SITE AREA: 7.04 ACRES
NET SITE AREA: 6.97 ACRES
FLOOR AREA: 720 SF. - (12'X60' OFFICE TRAILER PROPOSED)
MAX. ALLOWED FLOOR AREA RATIO: 2.0
PROPOSED FLOOR AREA RATIO: 0.002
- EXISTING USE: CURRENTLY VACANT. SITE CONTAINS REMNANTS OF THE FORMER CHILDREN'S DAY CAMP, WHICH OPERATED FROM THE LATE 1950S TO THE 1970S (SWIMMING POOL, BATH HOUSE, HORSE STABLES); INSTALLATION AND REPAIR OF A CITY WATER LINE OCCURRED ALONG THE WESTERN BOUNDARY; AND WAS MOST RECENTLY USED FOR AN UNAUTHORIZED TRUCK DRIVING SCHOOL ESTABLISHED WITHOUT REQUIRED DEVELOPMENT PERMITS, SUBJECT TO CODE VIOLATION CASE NC#121971.
- PROPOSED USE: THE PROJECT IMPACTS APPROXIMATELY 1.53 ACRES OF THE SITE. THE GRADED PAD AREA WILL BE SURFACED WITH DISINTEGRATED GRANITE TO MINIMIZE IMPACTS TO THE ON-SITE SENSITIVE ARCHAEOLOGICAL RESOURCE. THE PAD WILL BE USED FOR NEW VEHICLE STORAGE, TRUCK STORAGE ASSOCIATED WITH AN OFF-SITE TRUCK DRIVING INSTRUCTION FACILITY, AND MATERIALS AND EQUIPMENT STORAGE THAT WOULD NOT ADVERSELY IMPACT THE SENSITIVE BIOLOGY AND ARCHAEOLOGICAL RESOURCES ON-SITE. THE STORAGE OR PARKING OF INOPERABLE VEHICLES, HAZARDOUS/TOXIC EQUIPMENT AND MATERIALS WOULD NOT BE ALLOWED ON THIS SITE. THIS STORAGE/PARKING AREA WILL BE FENCED TO PRECLUDE INTRUSION INTO THE BIOLOGICAL AND STEEP HILLSIDE RESOURCES ON-SITE, AND TO FURTHER PROTECT THE ARCHAEOLOGICAL RESOURCE BY PREVENTING UNAUTHORIZED ACCESS ONTO THE SITE. ALL EQUIPMENT, CARS, TRUCKS, OR OTHER ALLOWED VEHICLES, AND MOBILE OFFICE, ARE RESTRICTED TO THE GRADED, D.G. PAD AREA OF THE SITE. SEE SHEET C-6 FOR PROPOSED E.S.L. COVENANT OF EASEMENT AREA.
- REMNANTS OF A SWIMMING POOL AND BATH HOUSE PERMITTED IN 1956-1957 WILL REMAIN IN PLACE.
- THIS PROJECT IS INTENDED TO FULFILL CODE VIOLATION COMPLIANCE REQUIREMENTS SPECIFIED IN THE STIPULATION IN FULL SETTLEMENT FOR FINAL JUDGEMENT OF PERMANENT INJUNCTION, SAN DIEGO COUNTY SUPERIOR COURT NO. 37-2007-00082605-CU-MC-CL, DATED 12/19/07.

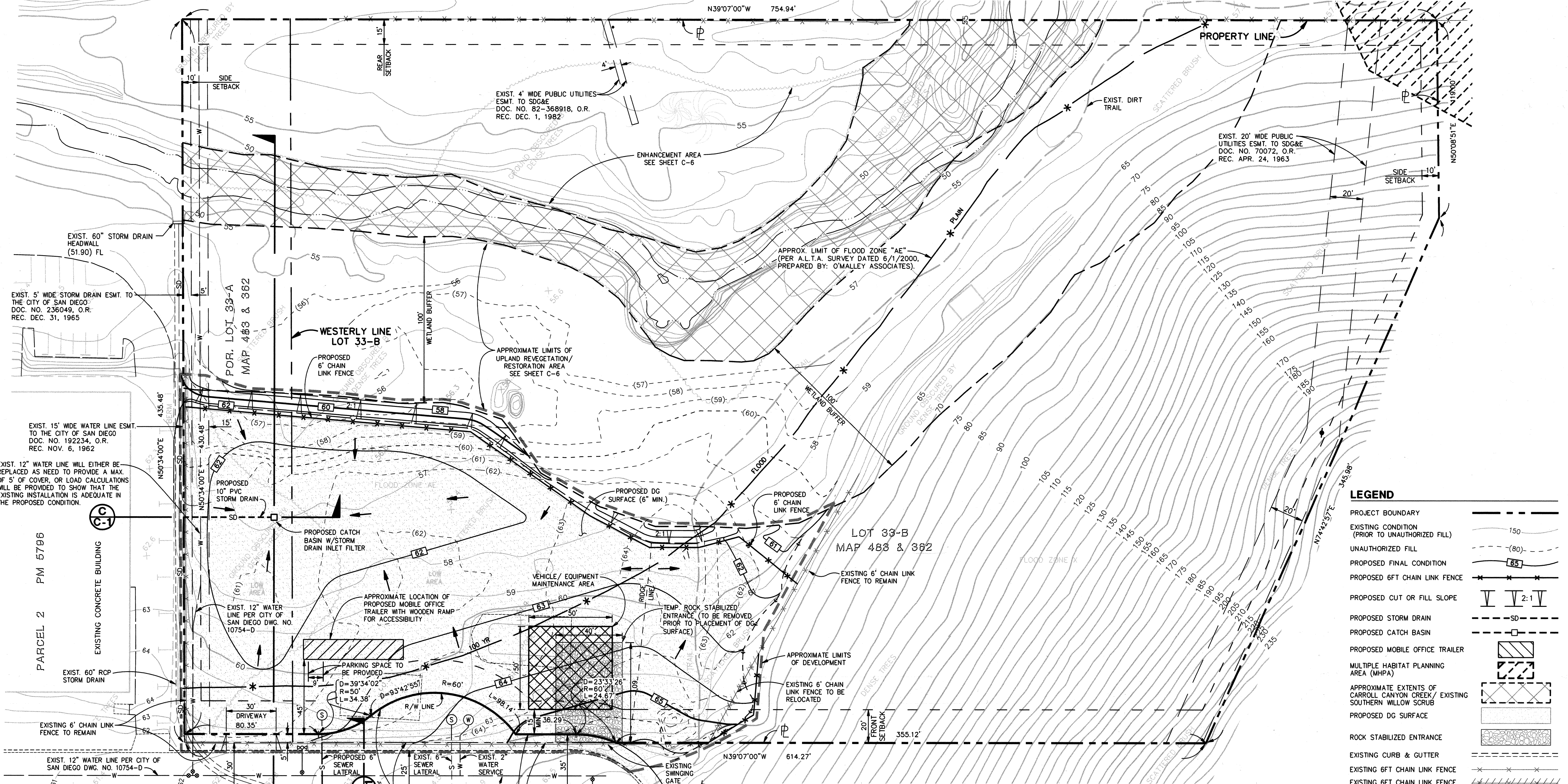

LEGEND

PROJECT BOUNDARY	---
EXISTING CONDITION (PRIOR TO UNAUTHORIZED FILL)	150
UNAUTHORIZED FILL	(80)
PROPOSED FINAL CONDITION	65
PROPOSED 6FT CHAIN LINK FENCE	---
PROPOSED CUT OR FILL SLOPE	V 2:1
PROPOSED STORM DRAIN	SD
PROPOSED CATCH BASIN	---
PROPOSED MOBILE OFFICE TRAILER	---
MULTIPLE HABITAT PLANNING AREA (MHPA)	---
APPROXIMATE EXTENTS OF CARROLL CANYON CREEK/ EXISTING SOUTHERN WILLOW SCRUB	---
PROPOSED DG SURFACE	---
ROCK STABILIZED ENTRANCE	---
EXISTING CURB & GUTTER	---
EXISTING 6FT CHAIN LINK FENCE	---
EXISTING 6FT CHAIN LINK FENCE TO BE REMOVED	---
100 YR FLOOD PLAIN	*
EXISTING WATER MAIN	W
EXISTING FIRE HYDRANT	DOH
EXISTING SEWER MAIN	S

GRADING TABULATIONS

ONSITE GRADING	1.5 AC.
TOTAL AREA ONSITE TO BE GRADED:	21% CUBIC YARDS
% OF TOTAL SITE TO BE GRADED:	380 CUBIC YARDS
AMOUNT OF FILL:	380 CUBIC YARDS
AMOUNT OF CUT:	380 CUBIC YARDS
AMOUNT OF DG (IMPORT):	1,050 CUBIC YARDS
AMOUNT OF EXPORT:	0 CUBIC YARDS
MAX. VERTICAL DEPTH OF CUT:	2.8 FEET
MAX. OVERALL HEIGHT OF CUT SLOPE:	2.0 FEET, 2:1 MAX. SLOPE RATIO
MAX. VERTICAL DEPTH OF FILL:	5.1 FEET
MAX. OVERALL HEIGHT OF FILL SLOPE:	5.0 FEET, 2:1 MAX. SLOPE RATIO
RETAINING/CRIB WALLS:	LENGTH: N/A, MAX. HEIGHT: N/A

*NOTE: QUANTITIES SHOWN DO NOT INCLUDE EXCAVATION FOR REMEDIAL GRADING OR ADJUSTMENTS DUE TO BULKING/SHRINKAGE.

GENERAL NOTES:

- PRIOR TO THE ISSUANCE OF ANY CONSTRUCTION PERMIT, THE APPLICANT SHALL INCORPORATE ANY CONSTRUCTION BEST MANAGEMENT PRACTICES NECESSARY TO COMPLY WITH CHAPTER 14, ARTICLE 2, DIVISION 1 (GRADING REGULATIONS) OF THE SAN DIEGO MUNICIPAL CODE INTO THE CONSTRUCTION PLANS OR SPECIFICATIONS.
- PRIOR TO THE ISSUANCE OF ANY CONSTRUCTION PERMIT, THE SUBDIVIDER SHALL ENTER INTO A MAINTENANCE AGREEMENT FOR THE ONGOING PERMANENT BMP MAINTENANCE.
- BUILDING ADDRESS NUMBERS SHALL BE VISIBLE AND LEGIBLE FROM THE STREET OR ROAD FRONTING THE PROPERTY, PER FHPS POLICY P-00-6 (UFC 901.4.4).
- IF AN EXISTING SEWER LATERAL IS UTILIZED, THE LATERAL SHALL BE INSPECTED USING A CLOSED-CIRCUIT TELEVISION (CCTV) BY A CALIFORNIA LICENSED PLUMBING CONTRACTOR TO VERIFY THE LATERAL IS IN GOOD WORKING CONDITION AND FREE OF ALL DEBRIS.
- THE WATER REVIEW SECTION HAS DETERMINED THAT UPSIZE OF THE EXISTING 8" DIAMETER WATER MAIN IN ROSELLE STREET TO A 12" DIAMETER WATER MAIN TO THE EXISTING DEAD END, TO INCLUDE THE REPLACEMENT OF THE EXISTING 12" X 12" TEE WITH THREE VALVES ARE NEEDED ADJACENT TO THE SUBJECT DEVELOPMENT. THE ROSELLE STREET PROJECT IS NOT SIGNIFICANT ENOUGH TO WARRANT THE WATER IMPROVEMENTS AT THIS TIME. THE APPLICANT SHOULD BE MADE AWARE THAT ANY REDEVELOPMENT/ REMODEL OF THE SITE WOULD REQUIRE THE WATER IMPROVEMENTS.

INDEX OF DRAWINGS

- SHEET C-1.....SITE PLAN / GRADING PLAN
- SHEET C-2.....EXISTING TOPOGRAPHIC MAP WITH UNAUTHORIZED GRADING
- SHEET C-3.....EXISTING TOPOGRAPHIC MAP PRIOR TO UNAUTHORIZED GRADING
- SHEET C-4.....TEMPORARY EROSION CONTROL FOLLOWING UNAUTHORIZED GRADING
- SHEET C-5.....E.S.L. ANALYSIS
- SHEET C-6.....VEGETATION / RESTORATION PLAN AND WETLAND ENHANCEMENT
- SHEET C-7.....SLOPE ANALYSIS
- SHEET C-8.....BUILDING DETAILS

ENGINEER OF WORK

Mark E. Stevens
R.C.E. 35502
DATE: 2/25/15

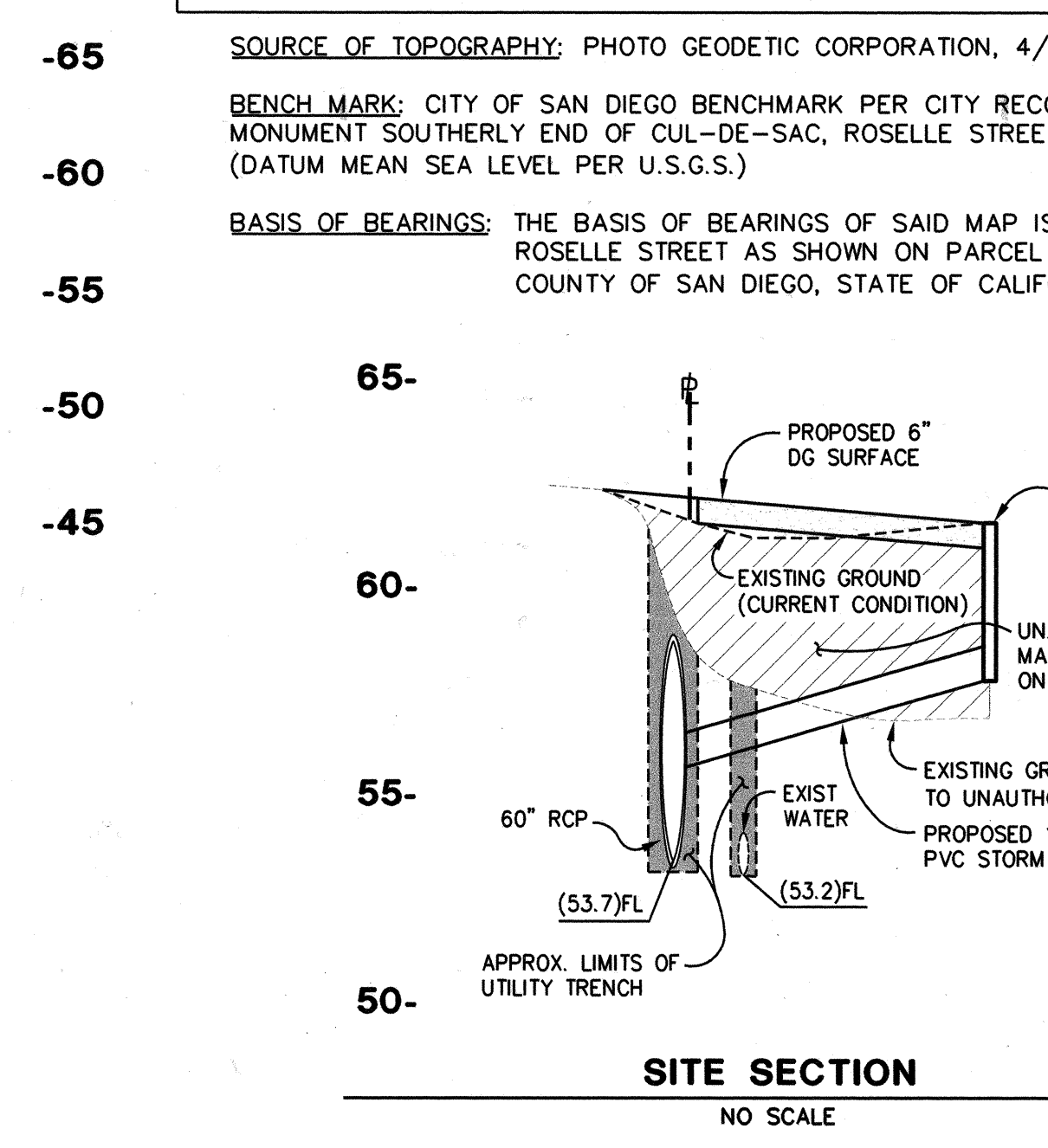
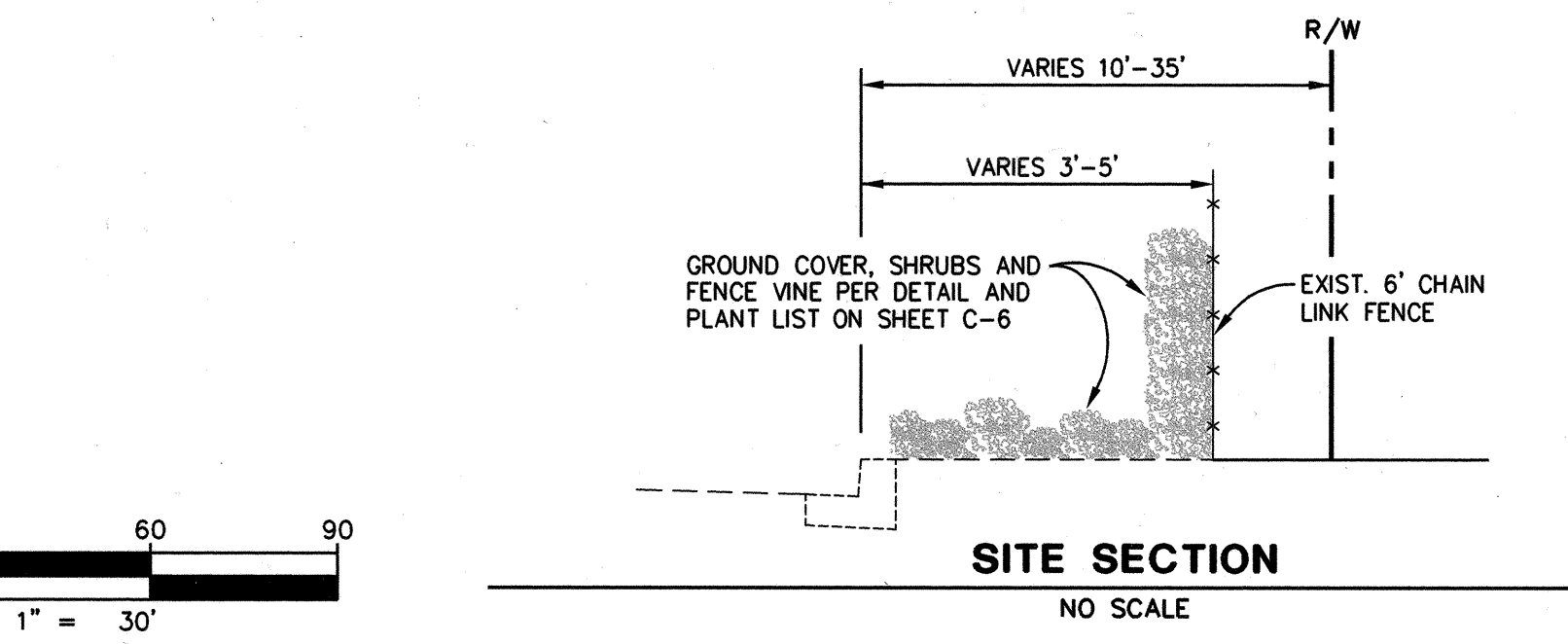
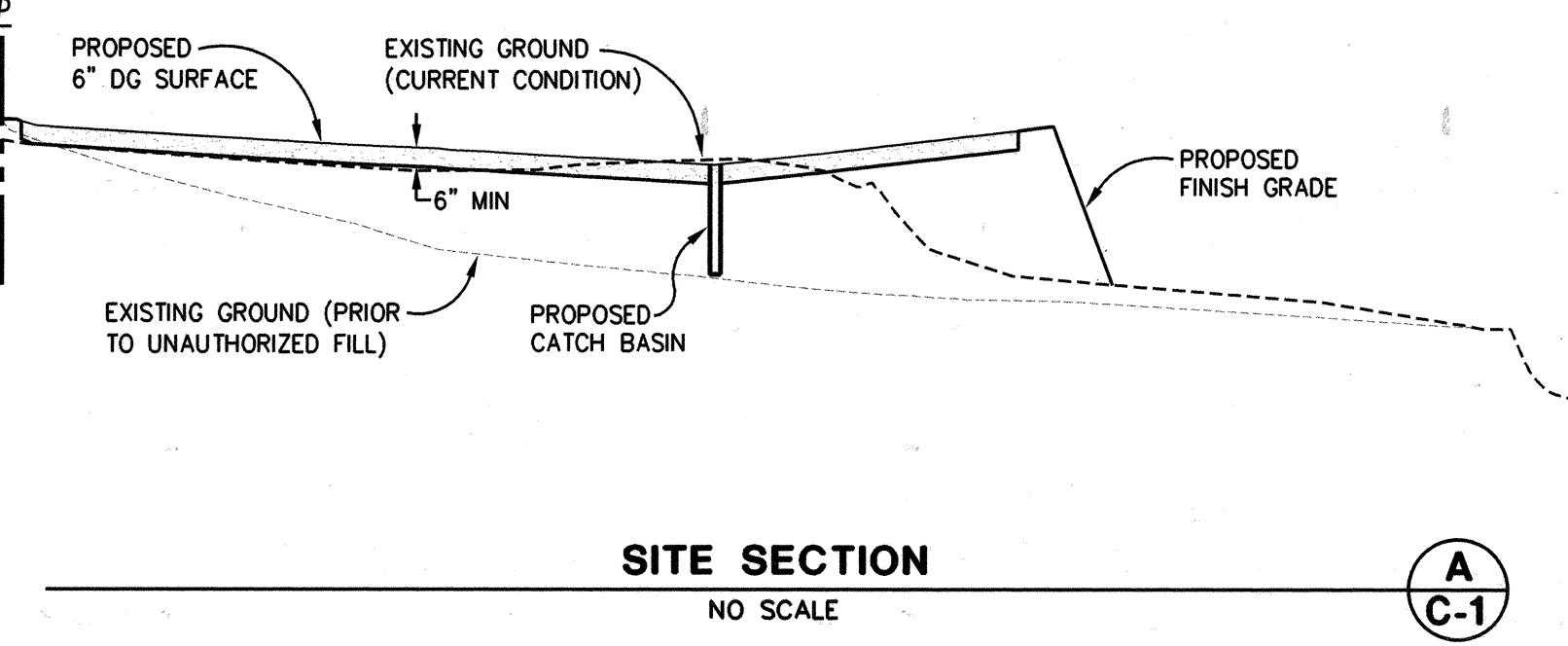
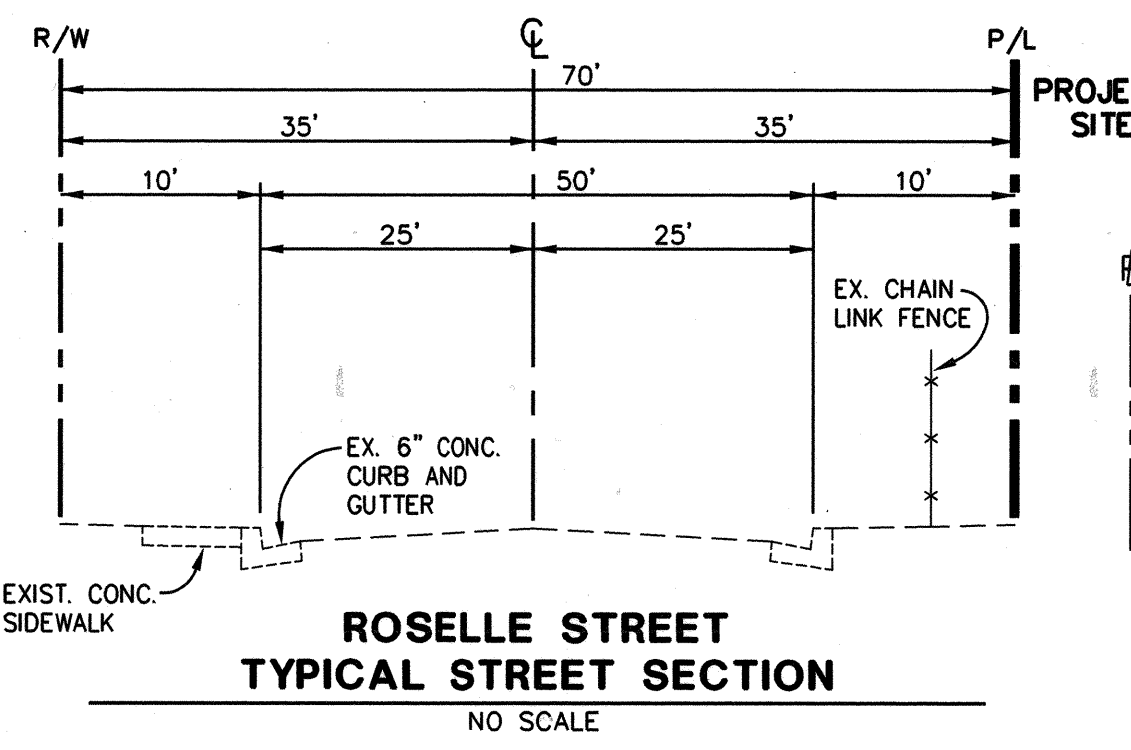
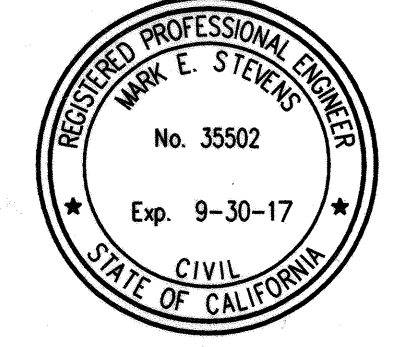

* PROJECT CONSULTANTS *

<p>PLANNER RBF CONSULTING CONTACT: CAROL CHASE 9755 CLAIREMONT MESA BLVD., #100 SAN DIEGO, CA. 92124 TEL: (858) 614-5000 FAX: (858) 614-5080</p>	<p>CIVIL ENGINEER STEVENS CRESTO ENGINEERING, INC CONTACT: MARK E. STEVENS 9665 CHESAPEAKE DRIVE, SUITE 200 SAN DIEGO, CA. 92124 TEL: (858) 694-5660 FAX: (858) 694-5661</p>
---	---

* PROJECT LOCATION *

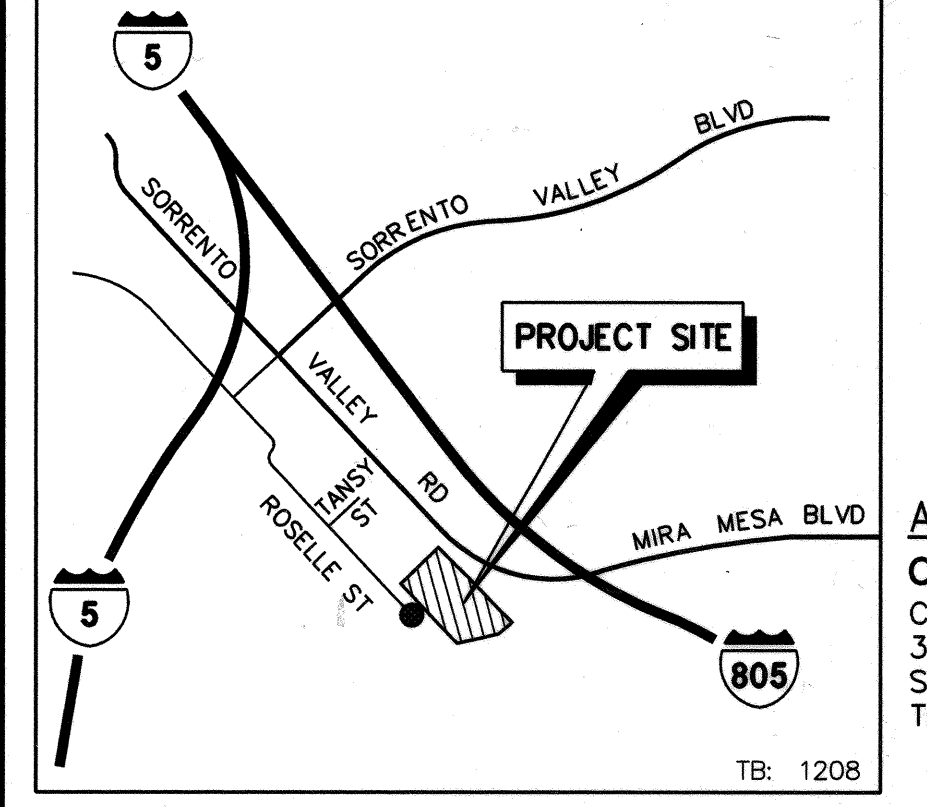

APPLICANT/OWNER
CLL-ROSELLE LLC
CONTACT: CHRIS LOUGHRIDGE
3565 RIVERA DRIVE
SAN DIEGO, CA. 92109
TEL: 858-272-4600

CCS 83 COORDINATE = 1905-6265
LAMBERT COORDINATE = 264-1705

<p>Prepared By: STEVENS CRESTO ENGINEERING 9665 CHESAPEAKE DRIVE SUITE 200 SAN DIEGO, CA. 92123 TEL: (858) 694-5660 FAX: (858) 694-5661</p>	<p>Revision 10: _____ Revision 9: _____ Revision 8: _____ Revision 7: _____ Revision 6: 02/26/15 Revision 5: 08/12/09 Revision 4: 05/11/09 Revision 3: 04/21/09 Revision 2: 11/25/08 Revision 1: 08/05/08</p>
<p>Project Address: 10325 ROSELLE STREET SORRENTO VALLEY, CA 92121</p>	<p>Original Date: 02/14/08 Sheet 1 of 8 PTS# 133029</p>

Project Name: ROSELLE STREET
Sheet Title: SITE PLAN / GRADING PLAN **C-1**

STEVENS CRESTO ENGINEERING, INC.
CIVIL ENGINEERS • PLANNERS • LAND SURVEYORS
9665 CHESAPEAKE DRIVE SUITE 200 SAN DIEGO, CA 92123-1352
PHONE: 858.694.5660 FAX: 858.694.5661 www.sceg.com

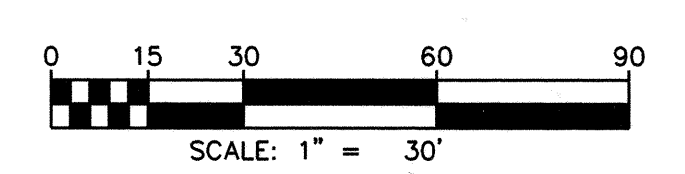

ROSELLE STREET

SITE DEVELOPMENT PERMIT / COASTAL DEVELOPMENT PERMIT

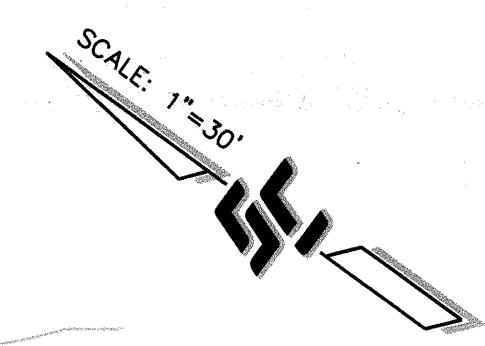

LEGEND

PROJECT BOUNDARY	---
EXISTING CONDITION (PRIOR TO UNAUTHORIZED FILL)	---
UNAUTHORIZED FILL	---(80)---
EXISTING CURB & GUTTER	---x---x---
EXISTING 6FT CHAIN LINK FENCE	---x---x---
100 YR FLOOD PLAIN	---
EXISTING WATER MAIN	---
EXISTING FIRE HYDRANT	DOJ
EXISTING SEWER MAIN	S---
MULTIPLE HABITAT PLANNING AREA (MHPA)	▨

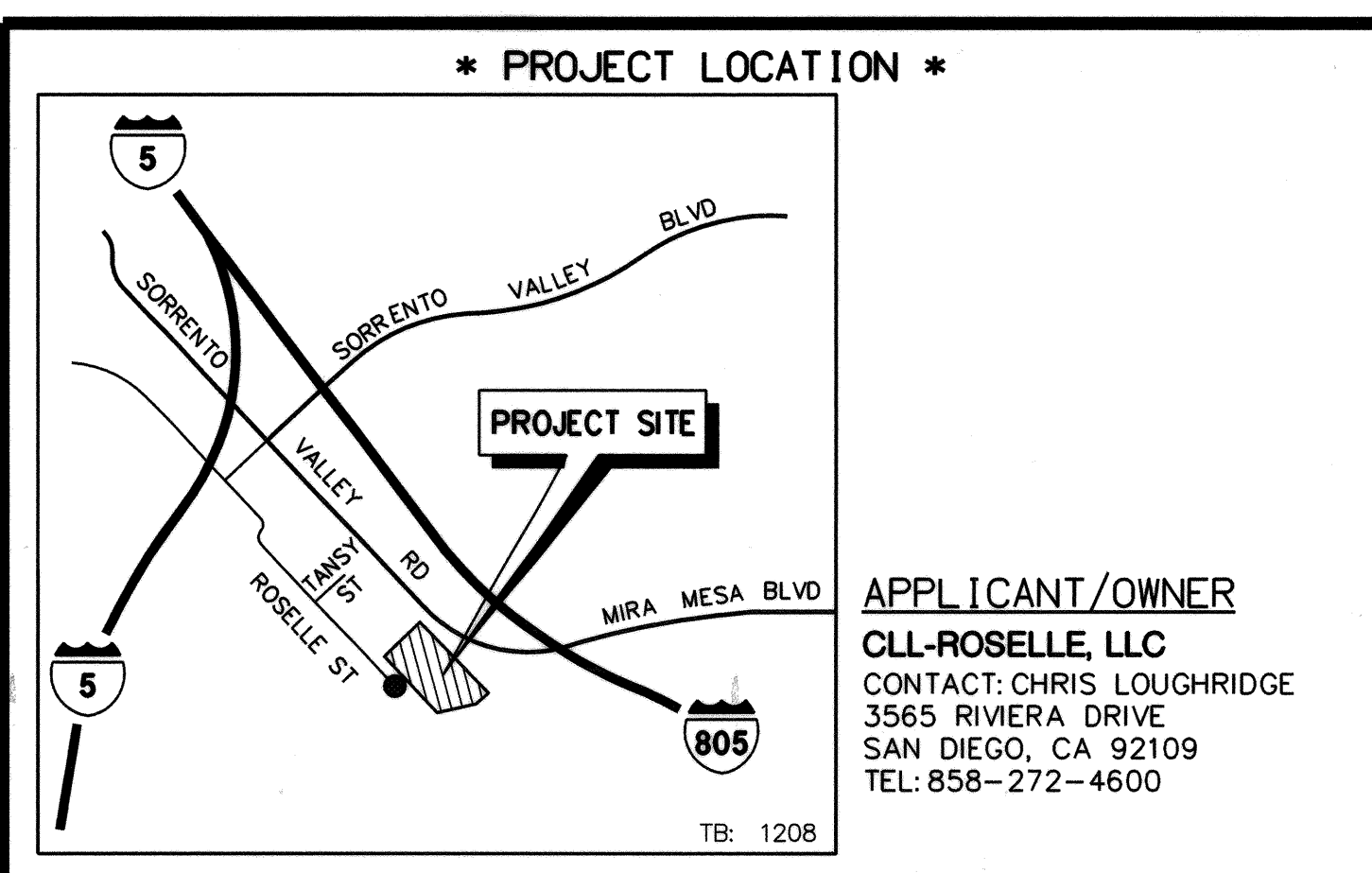
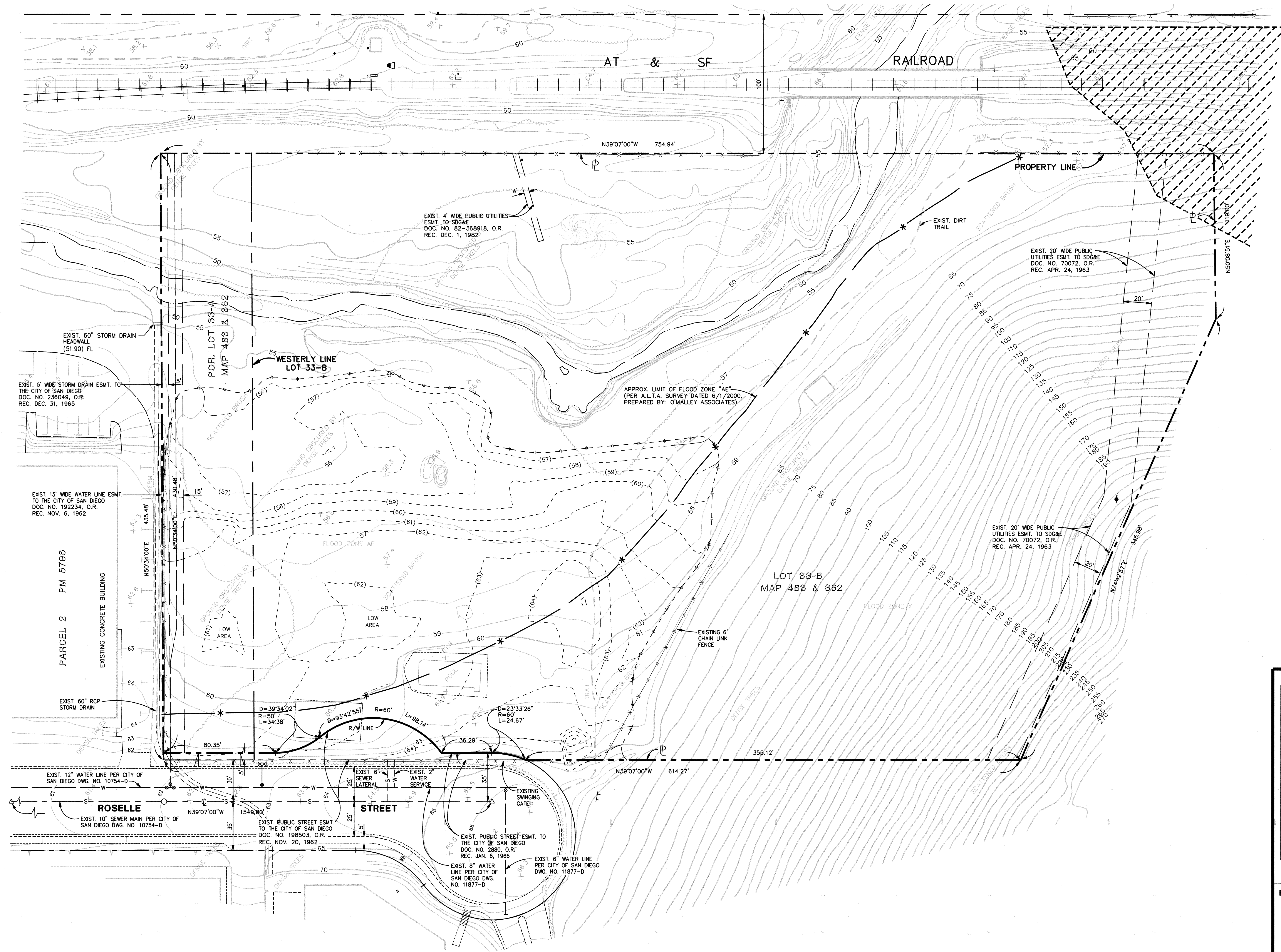

APPLICANT/OWNER
CLL-ROSELLE, LLC
 CONTACT: CHRIS LOUGHRIDGE
 3565 RIVIERA DRIVE
 SAN DIEGO, CA 92109
 TEL: 858-272-4600

CCS 88 COORDINATE = 1905-6265
 LAMBERT COORDINATE = 264-1705

Prepared By:
 STEVENS CRESTO ENGINEERING
 9665 CHESAPEAKE DRIVE
 SUITE 200
 SAN DIEGO, CA 92123
 TEL (858) 694-5660
 FAX (858) 694-5661

Project Address:
 10325 ROSELLE STREET
 SORRENTO VALLEY, CA 92121

Project Name:
ROSELLE STREET

Sheet Title:
EXISTING TOPOGRAPHIC WITH UNAUTHORIZED GRADING

Revision 10:	_____
Revision 9:	_____
Revision 8:	_____
Revision 7:	_____
Revision 6:	02/26/15
Revision 5:	08/12/09
Revision 4:	05/11/09
Revision 3:	04/21/09
Revision 2:	11/25/08
Revision 1:	08/05/08
Original Date:	02/14/08
Sheet	2 of 8
PTS#	133029

SC
STEVENS-CRESTO ENGINEERING, INC.
 CIVIL ENGINEERS - PLANNERS - LAND SURVEYORS
 9665 CHESAPEAKE DRIVE
 SUITE 200
 SAN DIEGO, CA 92123-1352
 PHONE: 858.694.5660
 FAX: 858.694.5661
 www.scengr.com

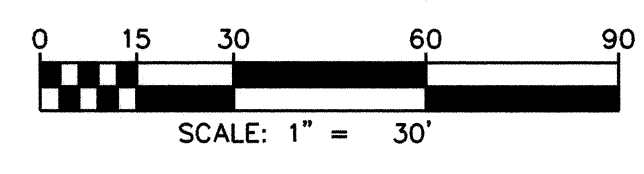

ENGINEER OF WORK

Mark E. Stevens
 MARK E. STEVENS
 R.C.E. 35502
 2/25/15
 DATE



C-2

ROSELLE STREET

SITE DEVELOPMENT PERMIT / COASTAL DEVELOPMENT PERMIT

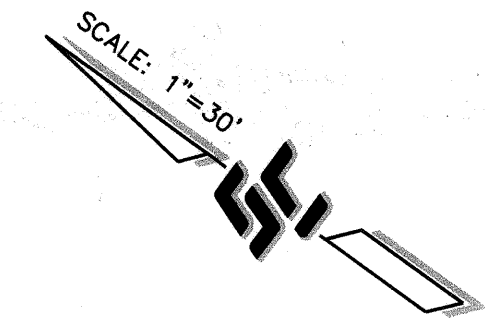

LEGEND

PROJECT BOUNDARY	---
EXISTING CONDITION (PRIOR TO UNAUTHORIZED FILL)	150
EXISTING CURB & GUTTER	---
EXISTING 6FT CHAIN LINK FENCE	---x---
100 YR FLOOD PLAIN	*
EXISTING WATER MAIN	W
EXISTING FIRE HYDRANT	⊕
EXISTING SEWER MAIN	S
MULTIPLE HABITAT PLANNING AREA (MHPA)	▨

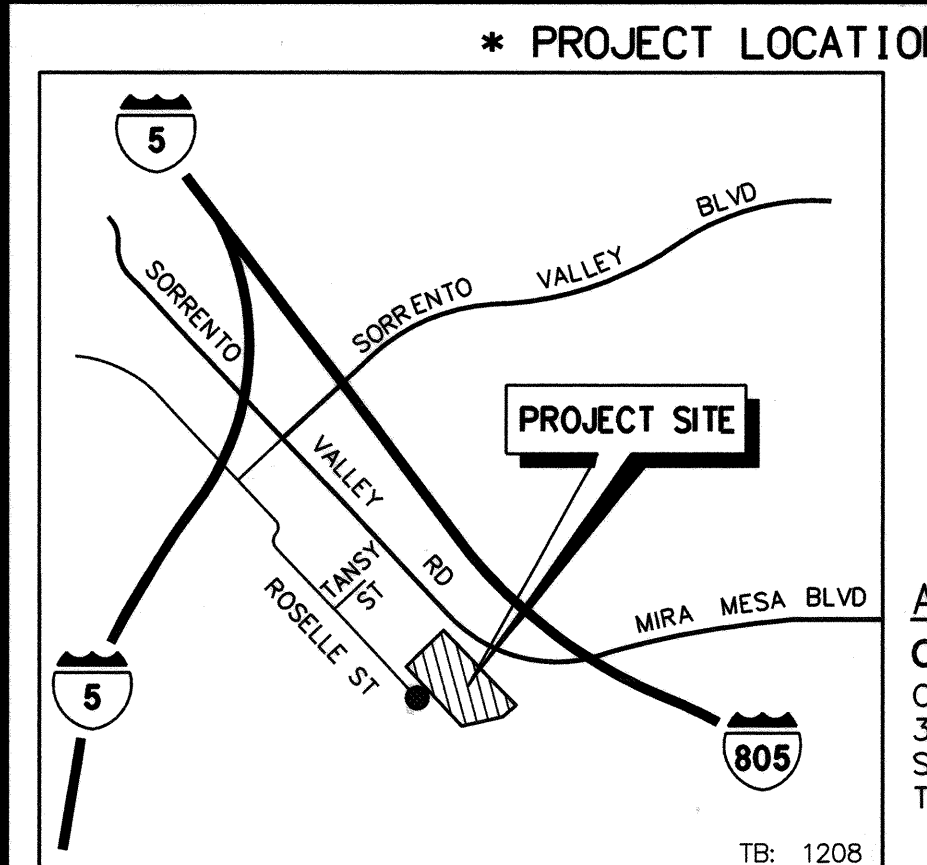
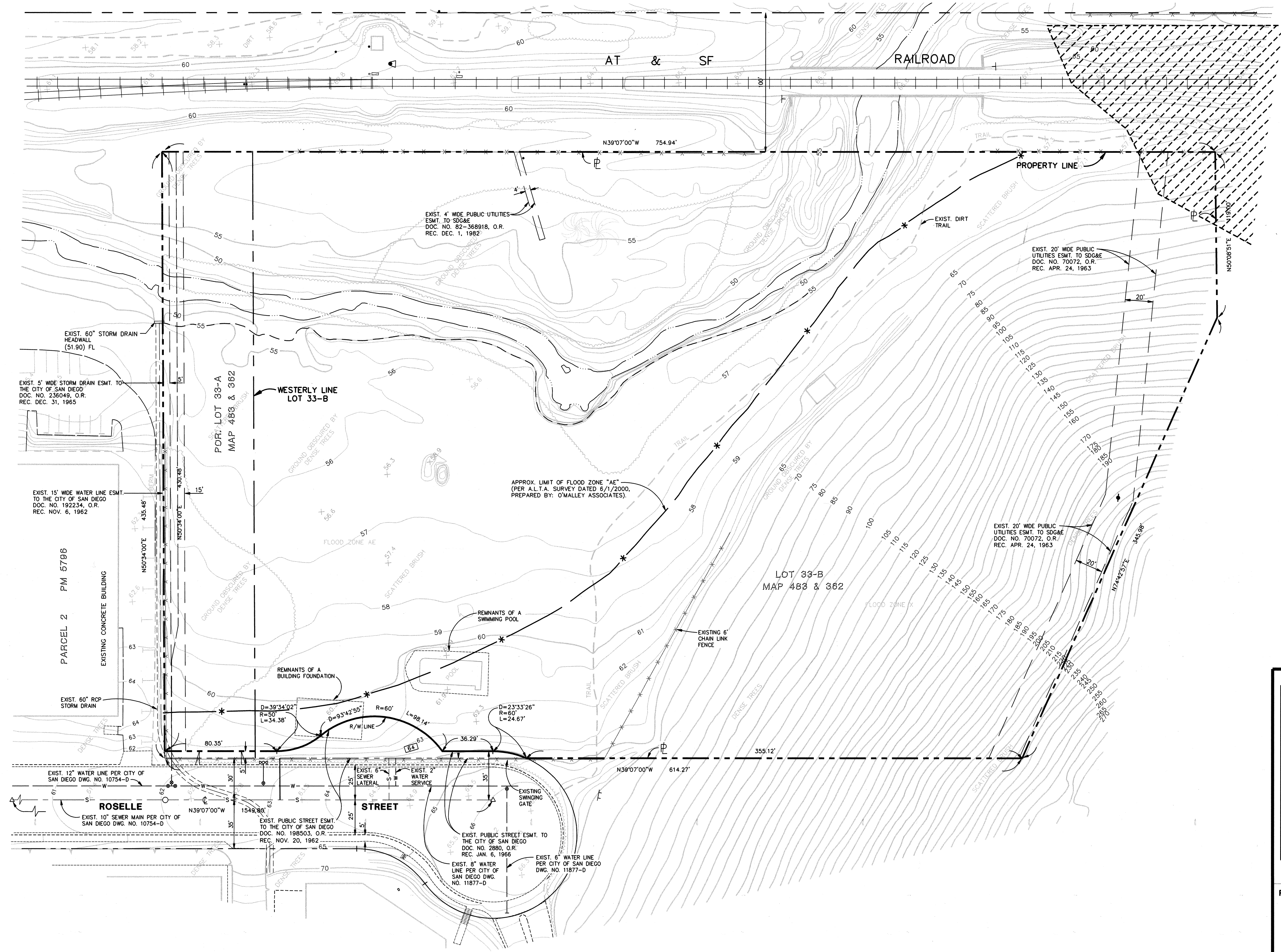

APPLICANT/OWNER
 CLL-ROSELLE, LLC
 CONTACT: CHRIS LOUGHRIDGE
 3565 RIVIERA DRIVE
 SAN DIEGO, CA 92109
 TEL: 858-272-4600

CCS 88 COORDINATE = 1905-6265
 LAMBERT COORDINATE = 264-1705

Prepared By: STEVENS CRESTO ENGINEERING 9665 CHESAPEAKE DRIVE SUITE 200 SAN DIEGO, CA 92123 TEL (858) 694-5660 FAX (858) 694-5661	Revision 10: _____ Revision 9: _____ Revision 8: _____ Revision 7: _____ Revision 6: 02/26/15 Revision 5: 08/12/09 Revision 4: 05/11/09 Revision 3: 04/21/09 Revision 2: 11/25/08 Revision 1: 08/05/08
Project Address: 10325 ROSELLE STREET SORRENTO VALLEY, CA 92121	Original Date: 02/14/08 Sheet 3 of 8 PTS# 133029
Project Name: ROSELLE STREET	

SC
STEVENS-CRESTO ENGINEERING, INC.
 CIVIL ENGINEERS - PLANNERS - LAND SURVEYORS
 9665 CHESAPEAKE DRIVE
 SUITE 200
 SAN DIEGO, CA 92123-1352
 PHONE: 858.694.5660
 FAX: 858.694.5661
 www.sceengr.com

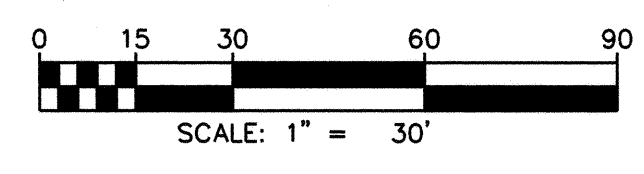

ENGINEER OF WORK

Mark E. Stevens
 MARK E. STEVENS
 R.C.E. 35502
 DATE: 2/25/15



Sheet Title:
 EXISTING TOPOGRAPHIC PRIOR
 TO UNAUTHORIZED GRADING

C-3

ROSELLE STREET

SITE DEVELOPMENT PERMIT / COASTAL DEVELOPMENT PERMIT NEIGHBORHOOD DEVELOPMENT PERMIT

LEGEND	SYMBOL
PROJECT BOUNDARY	
PROPOSED CONTOUR	
FIBER ROLL/STRAW WATTLES (CA STORMWATER BMP HANDBOOK SE-5)	
SILT FENCE (CA STORMWATER BMP HANDBOOK SE-1)	
STABILIZED CONSTRUCTION ENTRANCE (CA STORMWATER BMP HANDBOOK TC-1)	
HYDROSEEDED AREAS (MIN PER TABLE THIS SHEET) (CA STORMWATER BMP HANDBOOK EC-4)	
MULTIPLE HABITAT PLANNING AREA (MHPA)	

- ### EROSION AND SEDIMENT CONTROL NOTES
- TEMPORARY EROSION/SEDIMENT CONTROL, PRIOR TO COMPLETION OF FINAL IMPROVEMENTS, SHALL BE PERFORMED BY THE CONTRACTOR OR QUALIFIED PERSON AS INDICATED BELOW:
- ALL REQUIREMENTS OF THE CITY OF SAN DIEGO "LAND DEVELOPMENT MANUAL, STORM WATER STANDARDS" MUST BE INCORPORATED INTO THE DESIGN AND CONSTRUCTION OF THE PROPOSED GRADING/IMPROVEMENTS CONSISTENT WITH THE APPROVED STORM WATER POLLUTION PREVENTION PLAN (SWPPP) AND/OR WATER POLLUTION CONTROL PLAN (WPCP) FOR CONSTRUCTION LEVEL BMP'S AND FOR PERMANENT POST CONSTRUCTION TREATMENT CONTROL PERMANENT BMP'S, THE WATER QUALITY TECHNICAL REPORT (WQTR) IF APPLICABLE.
 - FOR STORM DRAIN INLET, PROVIDE A GRAVEL BAG SILT BASIN IMMEDIATELY UPSTREAM OF INLET AS INDICATED ON DETAILS.
 - FOR BAYS LOCATED AT SUMPS ADJACENT TO TOP OF SLOPES, THE CONTRACTOR SHALL ENSURE THAT WATER DRAINING TO THE SUMP IS DIRECTED INTO THE INLET AND THAT A MINIMUM OF 1.00' FREEBOARD EXISTS AND IS MAINTAINED ABOVE THE TOP OF THE INLET. IF FREEBOARD IS NOT PROVIDED BY GRADING SHOWN ON THESE PLANS, THE CONTRACTOR SHALL PROVIDE IT VIA TEMPORARY MEASURES, I.E. GRAVEL BAGS OR DIKES.
 - THE CONTRACTOR OR QUALIFIED PERSON SHALL BE RESPONSIBLE FOR CLEANUP OF SILT AND MUD ON ADJACENT STREET(S) DUE TO CONSTRUCTION ACTIVITY.
 - THE CONTRACTOR OR QUALIFIED PERSON SHALL CHECK AND MAINTAIN ALL LINED AND UNLINED DITCHES AFTER EACH RAINFALL.
 - THE CONTRACTOR SHALL REMOVE SILT AND DEBRIS AFTER EACH MAJOR RAINFALL.
 - EQUIPMENT AND WORKERS FOR EMERGENCY WORK SHALL BE MADE AVAILABLE AT ALL TIMES DURING THE RAINY SEASON. ALL NECESSARY MATERIALS SHALL BE STOCKPILED ON SITE AT CONVENIENT LOCATIONS TO FACILITATE RAPID CONSTRUCTION OF TEMPORARY DEVICES WHEN RAIN IS IMMINENT.
 - THE CONTRACTOR SHALL RESTORE ALL EROSION/SEDIMENT CONTROL DEVICES TO WORKING ORDER TO THE SATISFACTION OF THE CITY ENGINEER OR RESIDENT ENGINEER AFTER EACH RUN-OFF PRODUCING RAINFALL.
 - THE CONTRACTOR SHALL INSTALL ADDITIONAL EROSION/SEDIMENT CONTROL MEASURES AS MAY BE REQUIRED BY THE RESIDENT ENGINEER DUE TO UNCOMPLETED GRADING OPERATIONS OR UNFORESEEN CIRCUMSTANCES, WHICH MAY ARISE.
 - THE CONTRACTOR SHALL BE RESPONSIBLE AND SHALL TAKE NECESSARY PRECAUTIONS TO PREVENT PUBLIC TRESPASS ONTO AREAS WHERE IMPOUNDED WATERS CREATE A HAZARDOUS CONDITION.
 - HEREON ALL EROSION/SEDIMENT CONTROL MEASURES PROVIDED PER THE APPROVED GRADING PLAN SHALL BE INCORPORATED INTO THE CONSTRUCTION OF EACH WORKING DAY.
 - ALL EROSION/SEDIMENT CONTROL DEVICES SHOWN SHALL BE IN PLACE AT THE END OF EACH WORKING DAY WHEN RAIN IS IMMINENT.
 - THE CONTRACTOR SHALL ONLY GRADE, INCLUDING CLEARING AND GRUBBING FOR THE AREAS FOR WHICH THE CONTRACTOR OR QUALIFIED PERSON CAN PROVIDE EROSION/SEDIMENT CONTROL MEASURES.
 - THE CONTRACTOR SHALL ARRANGE FOR WEEKLY MEETINGS DURING OCTOBER 1ST TO APRIL 30TH FOR PROJECT TEAM (GENERAL CONTRACTOR, QUALIFIED PERSON, EROSION CONTROL SUBCONTRACTOR IF ANY, ENGINEER OF WORK, OWNER/DEVELOPER AND THE RESIDENT ENGINEER) TO EVALUATE THE ADEQUACY OF THE EROSION/SEDIMENT CONTROL MEASURES AND OTHER RELATED CONSTRUCTION ACTIVITIES.

- ### EMERGENCY EROSION CONTROL MEASURES NOTES:
- ALL BUILDING PADS TO BE DIKED AND MAINTAINED TO PREVENT WATER FROM FLOWING FROM THE PAD UNTIL THE STREETS AND DRIVEWAYS ARE PAVED AND WATER CAN FLOW FROM THE PADS WITHOUT CAUSING EROSION, OR CONSTRUCT DRAINAGE FACILITIES TO THE SATISFACTION OF THE CITY'S DEPARTMENT OF PUBLIC WORKS THAT WILL ALLOW WATER TO DRAIN FROM THE PAD WITHOUT CAUSING EROSION.
 - TOPS OF ALL SLOPES TO BE DIKED OR TRENCHED TO PREVENT WATER FROM FLOWING OVER THE CREST OF SLOPES.
 - MANUFACTURED SLOPES AND PADS SHALL BE ROUNDED VERTICAL AND HORIZONTALLY AS APPROPRIATE TO BLEND WITH THE SURROUNDING TOPOGRAPHY.
 - AS SOON AS CUTS OR EMBANKMENTS ARE COMPLETED, BUT NOT LATER THAN NOVEMBER 1, (IF COASTAL PERMITS ARE REQUIRED, NO LATER THAN OCTOBER 1) ALL CUT AND FILL SLOPES SHALL BE STABILIZED WITH A HYDROMULCH MIXTURE OR AN EQUAL TREATMENT APPROVED BY THE CITY'S DEPARTMENT OF PUBLIC WORKS. BETWEEN NOVEMBER 1 (OR OCTOBER 1, IF COASTAL PERMIT IS REQUIRED) AND APRIL 15 APPROVED SLOPE PROTECTION MEASURES SHALL PROCEED IMMEDIATELY BEHIND THE EXPOSURE OF CUT SLOPES AND/OR THE CREATION OF EMBANKMENT SLOPES.
 - CATCH BASINS, DESILTING BASINS AND STORM DRAIN SYSTEMS SHALL BE INSTALLED TO THE SATISFACTION OF THE CITY'S DEPARTMENT OF PUBLIC WORKS.
 - GRAVEL BAG CHECK DAMS TO BE PLACED IN A MANNER APPROVED BY THE CITY'S DEPARTMENT OF PUBLIC WORKS IN UNPAVED STREETS WITH GRADIENTS IN EXCESS OF 2% AND ON OR IN OTHER GRADED OR EXCAVATED AREAS AS REQUIRED BY THE CITY'S DEPARTMENT OF PUBLIC WORKS.
 - THE DEVELOPER TO MAINTAIN THE EROSION CONTROL MEASURES DESCRIBED ABOVE UNTIL RELIEVED OF SAME BY THE CITY'S DEPARTMENT OF PUBLIC WORKS. THE DEVELOPER TO REMOVE ALL SOIL INTERCEPTED BY THE GRAVEL BAGS, CATCH BASINS AND DESILTING BASINS AND KEEP THESE FACILITIES CLEAN AND FREE OF SILT AND SAND AS DIRECTED BY THE CITY'S DEPARTMENT OF PUBLIC WORKS. THE DEVELOPER SHALL REPAIR ANY ERODED SLOPES AS DIRECTED BY THE CITY'S DEPARTMENT OF PUBLIC WORKS.

TEMPORARY EROSION CONTROL HYDROSEED MIX

LBS. PER ACRE	BOTANICAL SEED NAME	COMMON NAME
2.10	ARTEMESIA CALIFORNICA	CALIFORNIA SAGEBRUSH
0.80	ERIOGONUM FASCICULATUM	CALIFORNIA BUCKWHEAT
3.00	DENOTHERA CHEINANTHIFOLIA	BEACH EVENING PRIMROSE
20.00	PLANTAGO INDICA	PLANTAIN
3.00	SALVIA MELLIFERA	BLACK SAGE

- TOTAL LBS. 28.90
- NEW SLOPES AND DISTURBED AREAS (WHEN APPLICABLE PER NOTE 3 BELOW) SHALL BE HYDROSEEDED WITH THE MIX NOTED ABOVE. FULL SITE PLANTING AND IRRIGATION SHALL BE PROVIDED PER LANDSCAPE PLAN - PTS NO.
- PRIOR TO THE ACCEPTANCE OF HYDROSEEDED AREAS, IF ANY, BY THE CITY OF SAN DIEGO RESIDENT ENGINEER, A CERTIFICATE MUST BE SUBMITTED BY A REGISTERED LANDSCAPE ARCHITECT STATING THAT HYDROSEEDING WAS DONE ACCORDING TO THE PROJECT SPECIFICATIONS AND THAT ITS GROWTH IS ADEQUATELY ESTABLISHED TO PREVENT EROSION.
- DISTURBED AND GRADED PAD AREAS, WHERE NO CONSTRUCTION WILL OCCUR WITHIN 45 DAYS AFTER COMPLETION OF GRADING, SHALL BE HYDROSEEDED WITH DROUGHT TOLERANT AND NON-INVASIVE SEED MIX TO PREVENT EROSION.

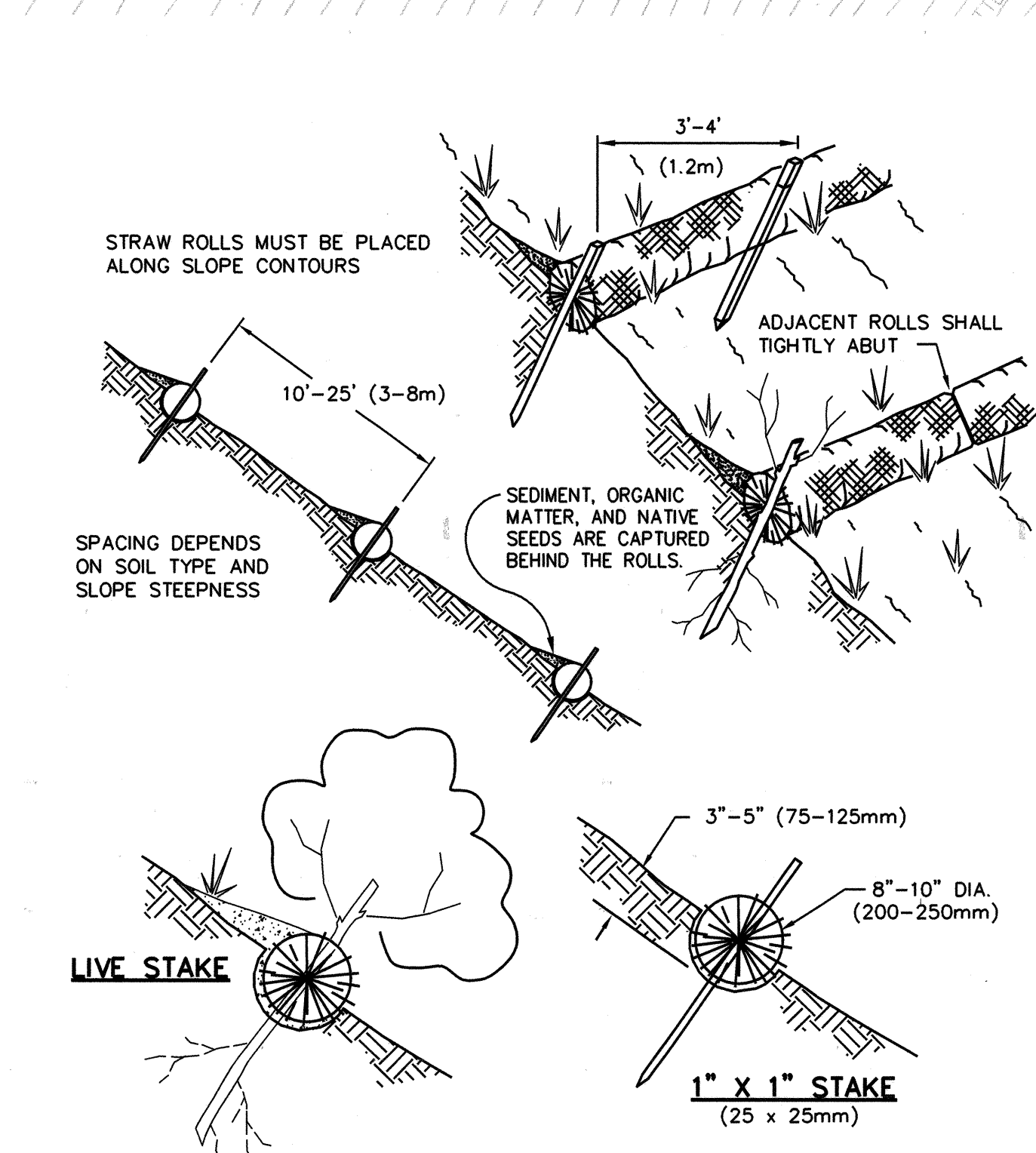
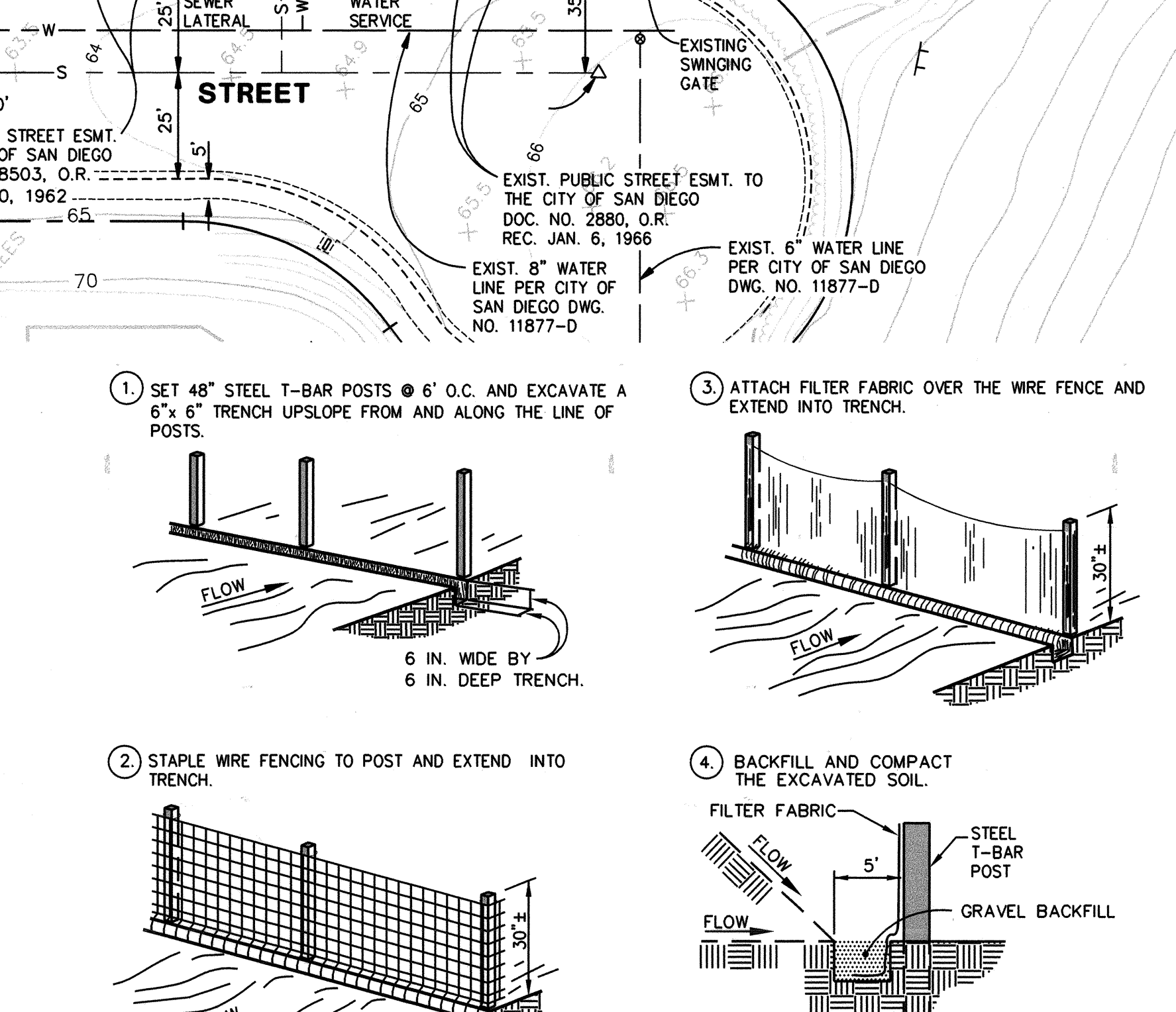
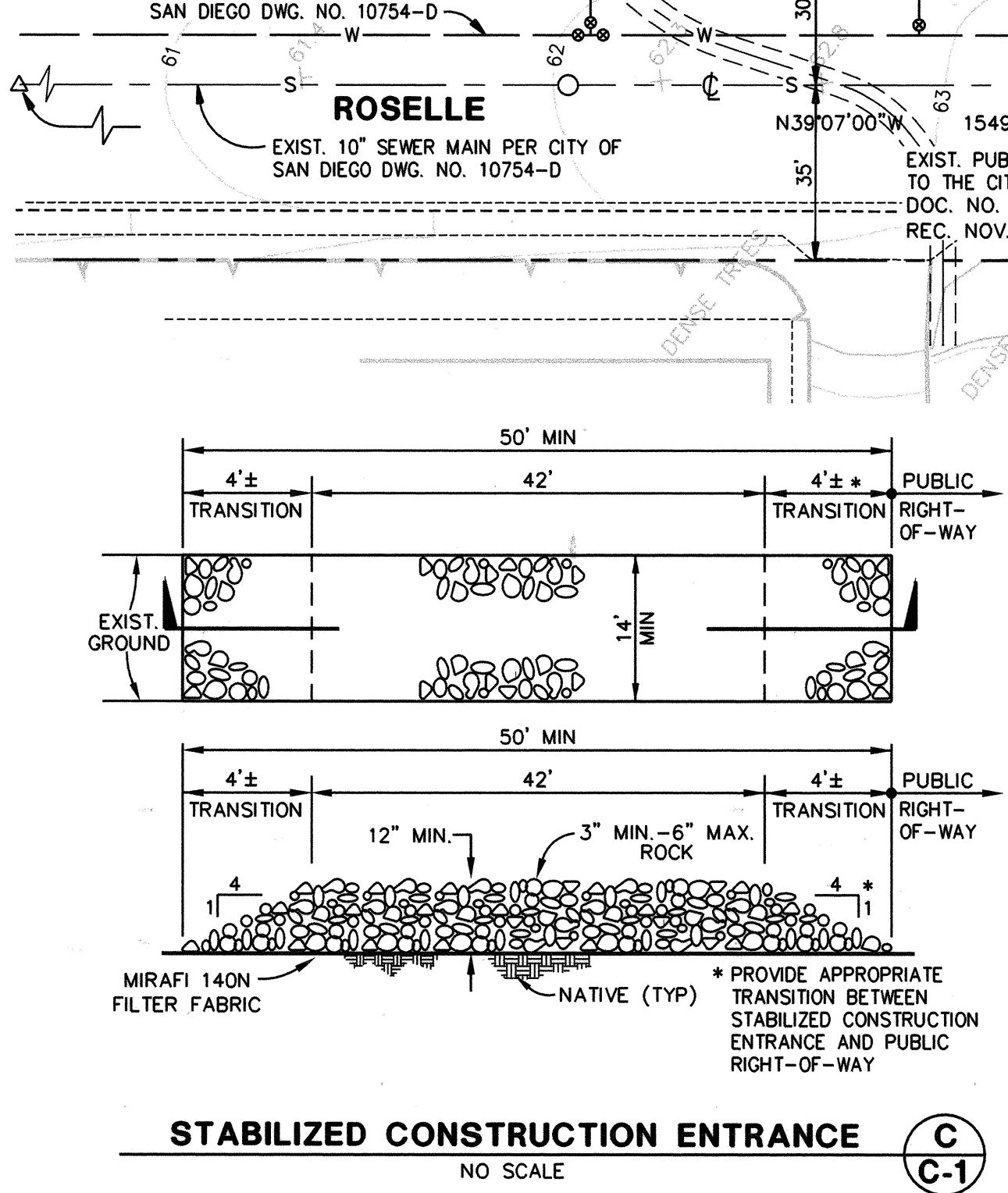
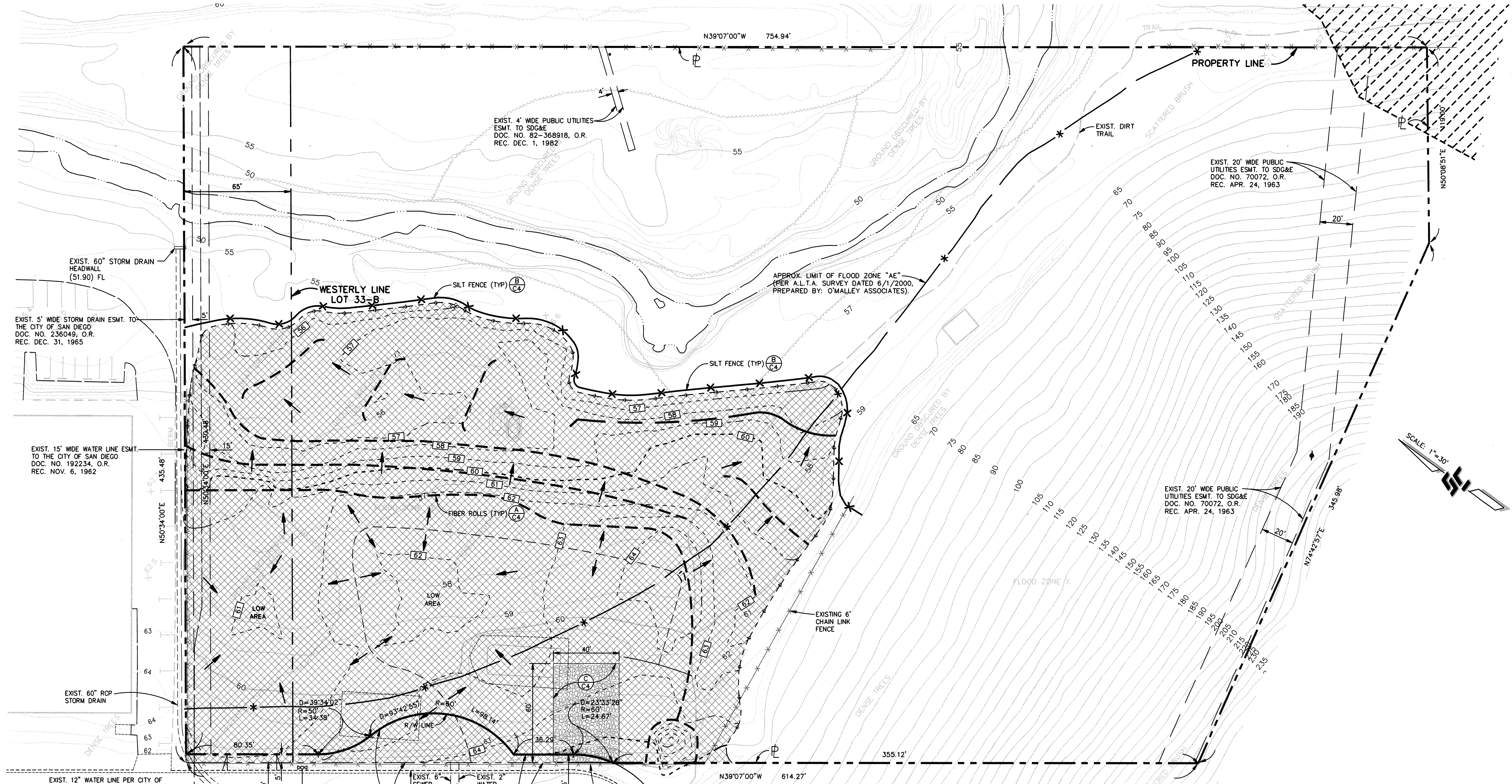

STABILIZED CONSTRUCTION ENTRANCE
NO SCALE
C-1

SILT FENCE
NO SCALE
B
C-1

FIBER ROLLS
NO SCALE
A
C-1

ENGINEER OF WORK
MARK E. STEVENS
R.P.C. 35502
2/25/15
DATE

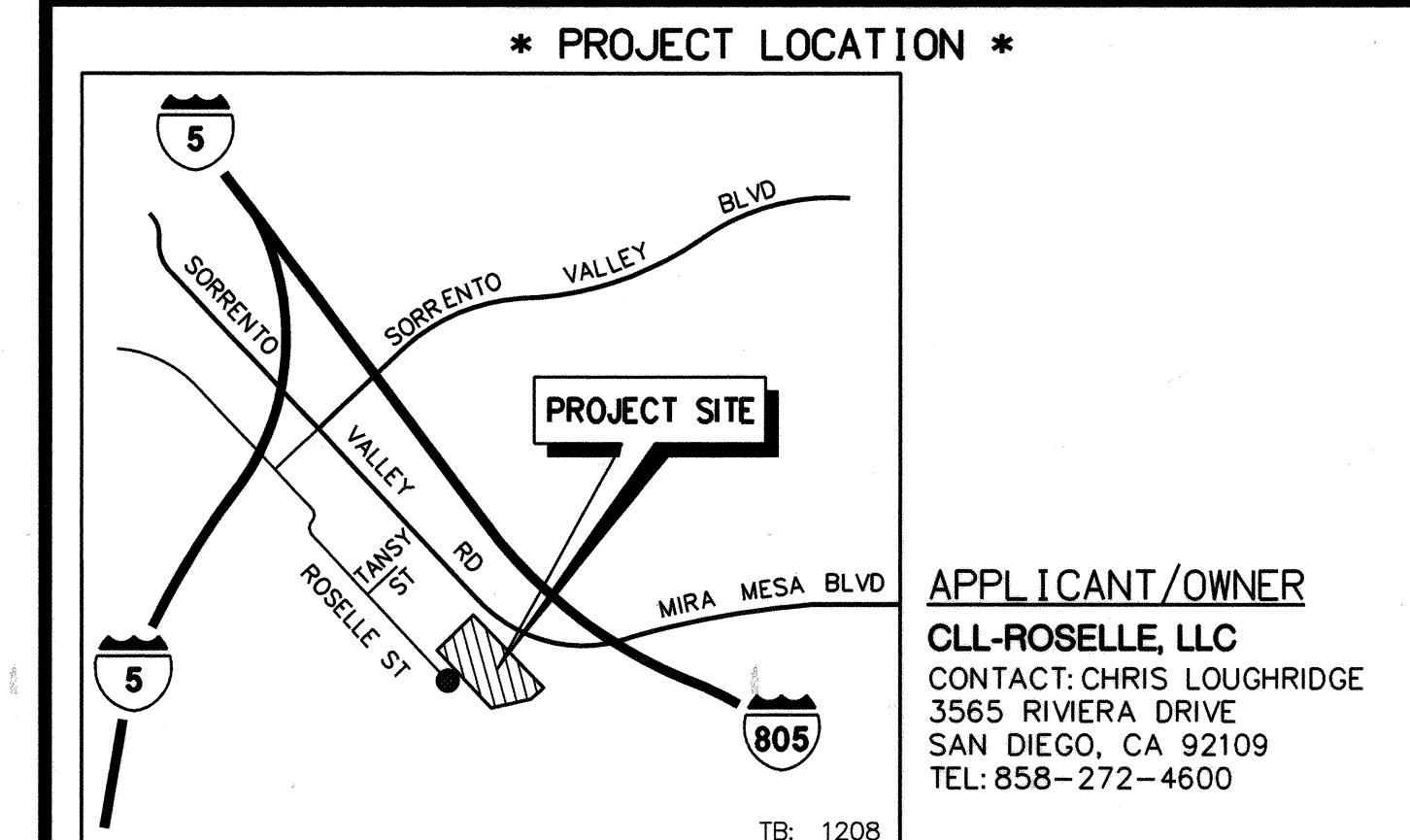

APPLICANT/OWNER
CLL-ROSELLE, LLC
CONTACT: CHRIS LOUGHRIDGE
3565 RIVIERA DRIVE
SAN DIEGO, CA 92109
TEL: 858-272-4600

**CCS 83 COORDINATE = 1905-6265
LAMBERT COORDINATE = 264-705**

Prepared By:
STEVENS CRESTO ENGINEERING
9665 CHESAPEAKE DRIVE
SUITE 200
SAN DIEGO, CA 92123
TEL (858) 694-5660
FAX (858) 694-5661

Project Address:
10325 ROSELLE STREET
SORRENTO VALLEY, CA 92121

Project Name:
ROSELLE STREET

Sheet Title:
TEMPORARY EROSION CONTROL FOLLOWING UNAUTHORIZED GRADING

Revision 10: _____
Revision 9: _____
Revision 8: _____
Revision 7: _____
Revision 6: _____
Revision 5: 02/26/15
Revision 4: 05/11/09
Revision 3: 04/21/09
Revision 2: 11/25/08
Revision 1: 08/05/08
Original Date: 02/14/08
Sheet 4 of 8
PTS# 133029

STEVENS-CRESTO ENGINEERING, INC.
CIVIL ENGINEERS - PLANNERS - LAND SURVEYORS
9665 CHESAPEAKE DRIVE
SUITE 200
SAN DIEGO, CA 92123-1352
PHONE: 858.694.5660
FAX: 858.694.5661
www.sceengr.com

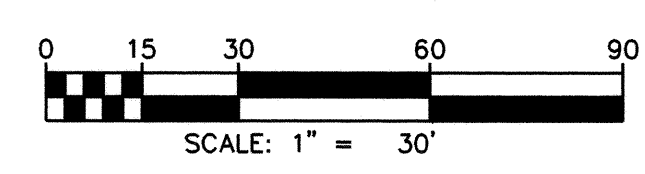

C-4

ROSELLE STREET

SITE DEVELOPMENT PERMIT / COASTAL DEVELOPMENT PERMIT NEIGHBORHOOD DEVELOPMENT PERMIT

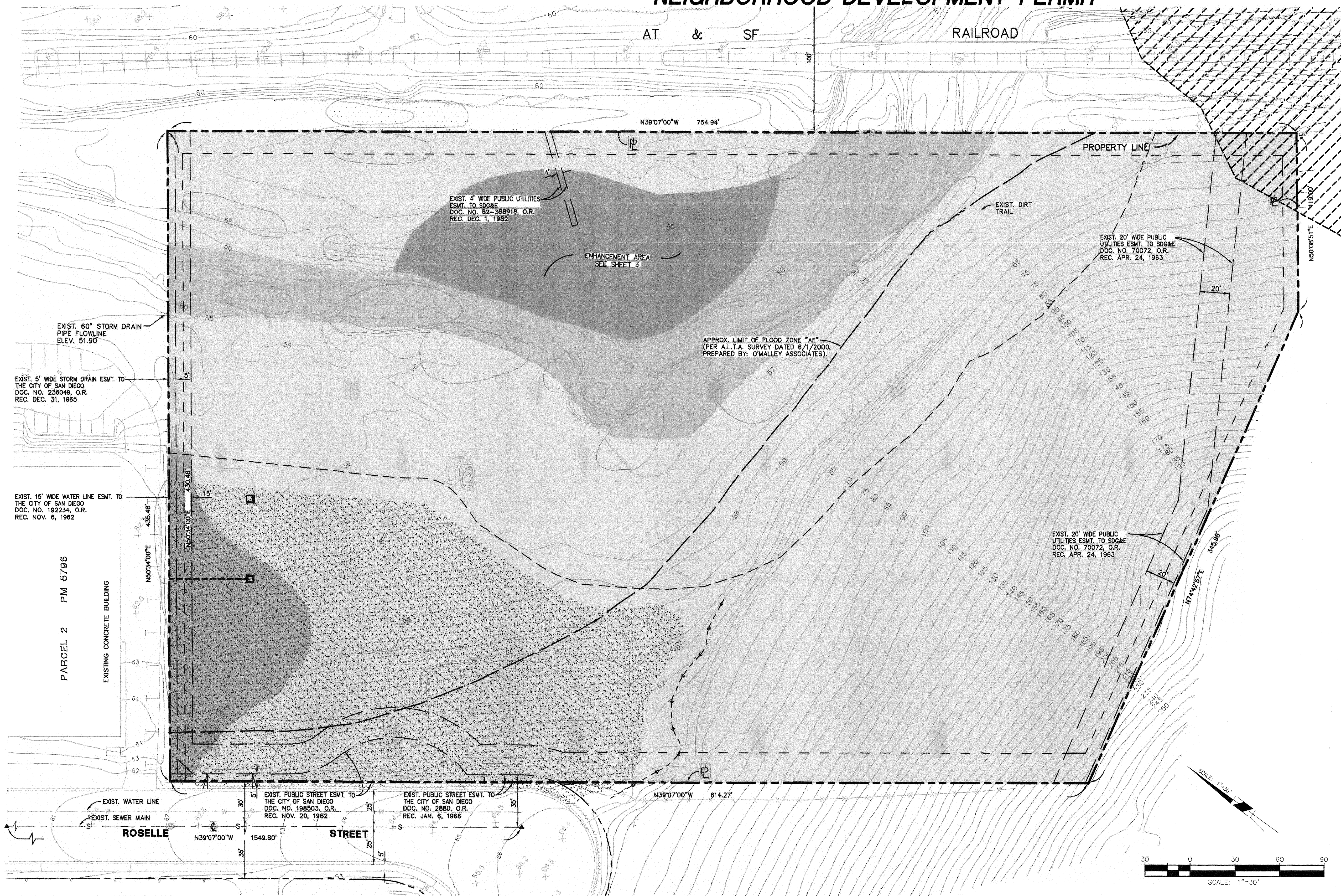

PROPOSED ESL COVENANT OF EASEMENT AREA
EASEMENT WOULD ALLOW FOR MAINTENANCE OF FACILITIES AND SENSITIVE HABITAT.

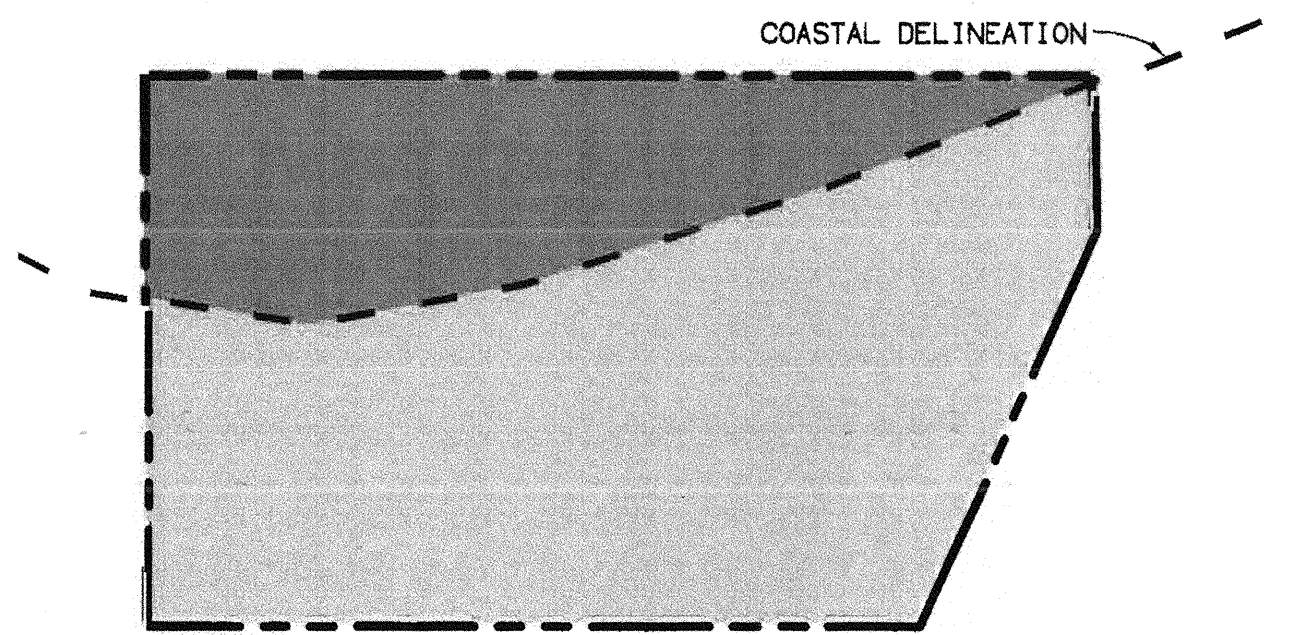

COASTAL DELINEATION DETAIL
PROJECT AREA IS WITHIN COASTAL ZONE

- LEGEND:**
- SWS** SOUTHERN WILLOW SCRUB
 - DSWS-C** DISTURBED SOUTHERN WILLOW SCRUB
 - RUD** RUDERAL HABITAT
 - EUC** EUCALYPTUS WOODLAND
 - PALMER SAGEWORT (ARTEMISIA PALMERI)
 - EXISTING MHPA AREA

SENSITIVE LANDS ANALYSIS

TOTAL PROJECT AREA	7.04 AC
100-YEAR FLOODPLAIN AREA	3.64 AC
SENSITIVE COASTAL BLUFF AREA	NONE
AREA IN COASTAL OVERLAY ZONE	7.04 AC
AREA IN STEEP SLOPE	2.42 AC (SEE SHEET 7 FOR SLOPE ANALYSIS)
AREA IN MHPA	0.05 AC (NO IMPACT)

*** PROJECT CONSULTANTS ***

<p>PLANNER RBF CONSULTING CONTACT: CAROL CHASE 9755 CLAIREMONT MESA BLVD., #100 SAN DIEGO, CA 92124 TEL: (858) 614-5000 FAX: (858) 614-5080</p>	<p>CIVIL ENGINEER STEVENS CRESTO ENGINEERING, INC CONTACT: MARK E STEVENS 9565 CHESAPEAKE DRIVE, SUITE 200 SAN DIEGO, CA 92123 TEL: (858) 614-5000 FAX: (858) 694-5661</p>
--	---

*** PROJECT LOCATION ***

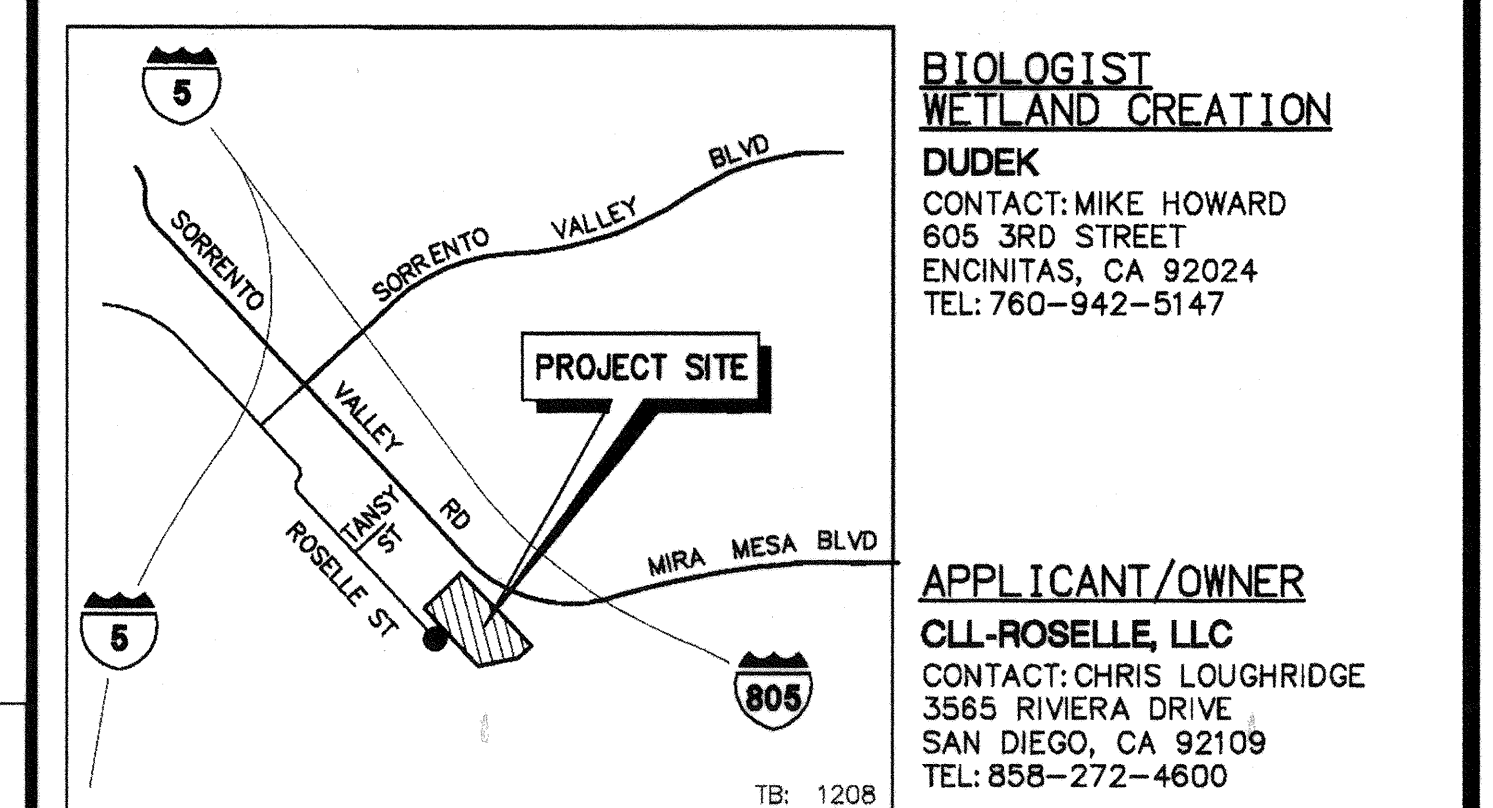

BIOLOGIST
WETLAND CREATION
DUDEK
CONTACT: MIKE HOWARD
605 3RD STREET
ENCINITAS, CA 92024
TEL: 760-942-5147

APPLICANT/OWNER
CLL-ROSELLE, LLC
CONTACT: CHRIS LOUGHBRIDGE
3565 RIVIERA DRIVE
SAN DIEGO, CA 92109
TEL: 858-272-4600

CCS 83 COORDINATE = 1905-6265
LAMBERT COORDINATE = 265-1705

Prepared By:
RBF CONSULTING
CONTACT PERSON: CAROL CHASE
9755 CLAIREMONT MESA BLVD., #100
SAN DIEGO, CA 92124
TEL: (858) 614-5000
FAX: (858) 810-1450

Project Address:
10325 ROSELLE STREET
SORRENTO VALLEY, CA 92121

Project Name:
ROSELLE STREET

Original Date: 2/14/08
Sheet: 5 of 8
PTS#: 133029

Revision 10:	
Revision 9:	
Revision 8:	
Revision 7:	
Revision 6:	
Revision 5:	
Revision 4:	08/12/07
Revision 3:	5/11/08
Revision 2:	11/25/08
Revision 1:	8/5/08
Original Date:	2/14/08

BIOLOGICAL HABITAT TABULATIONS UNAUTHORIZED GRADING

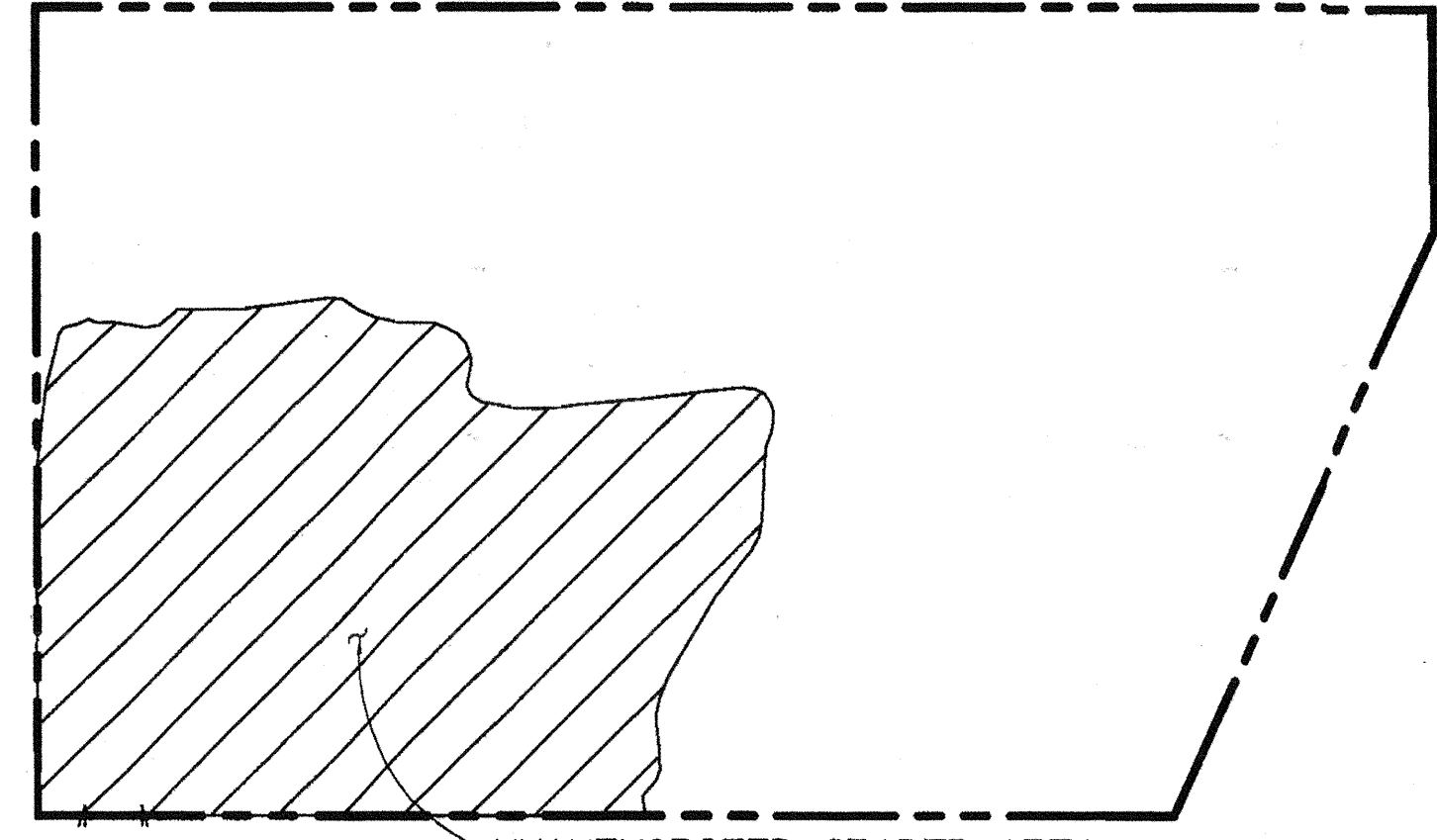

TABLE 1

HABITAT	TIER	TOTAL AREA	IMPACT	% OF IMPACT
SWS	WETLANDS	0.66 AC	0.02 AC*	2.5%
DSWS-C	WETLANDS	0.45 AC	0.00 AC	0.0%
EUC	IV	0.27 AC	0.26 AC	97.6%
RUD	IV	5.66 AC	1.84 AC	32.5%
TOTAL		7.04 AC	2.12 AC	30.1%

* PROJECT PROPOSES WETLAND ENHANCEMENT FOR THE 0.02 ACRE OF SOUTHERN WILLOW SCRUB IMPACTED. SEE SHEET C-5 FOR ENHANCEMENT AREA.

NOTE:
A MINOR DIFFERENCE IN THE TOTAL SOUTHERN WILLOW SCRUB ACREAGE ON THE SITE IS THE RESULT OF A SMALL INACCURACY IN THE PREVIOUS MAPPING OF VEGETATION, WHICH WAS RECTIFIED IN THE CURRENT MAPPING OF THE SITE.

BIOLOGICAL HABITAT TABULATIONS PROPOSED PROJECT

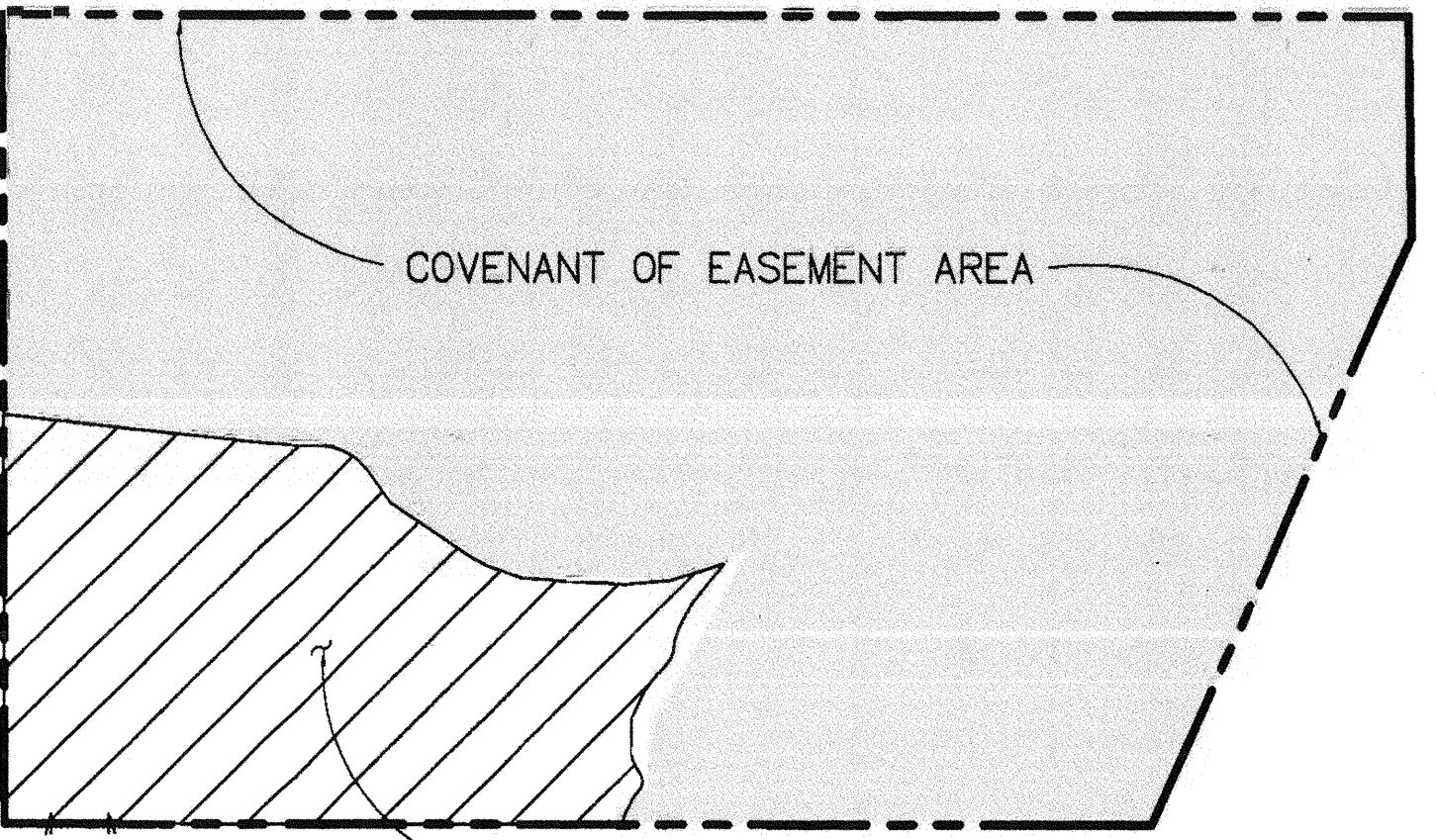

TABLE 2

HABITAT	TIER	TOTAL AREA	IMPACT	% OF IMPACT
SWS	WETLANDS	0.70 AC	0.00 AC	0.0%
DSWS-C	WETLANDS	0.45 AC	0.00 AC	0.0%
EUC	IV	0.27 AC	0.27 AC	100.0%
RUD	IV	5.62 AC	1.26 AC	22.4%
TOTAL		7.04 AC	1.53 AC	21.7%

NOTE:
A MINOR DIFFERENCE IN THE TOTAL SOUTHERN WILLOW SCRUB ACREAGE ON THE SITE IS THE RESULT OF A SMALL INACCURACY IN THE PREVIOUS MAPPING OF VEGETATION, WHICH WAS RECTIFIED IN THE CURRENT MAPPING OF THE SITE.

ROSELLE STREET

SITE DEVELOPMENT PERMIT / COASTAL DEVELOPMENT PERMIT NEIGHBORHOOD DEVELOPMENT PERMIT

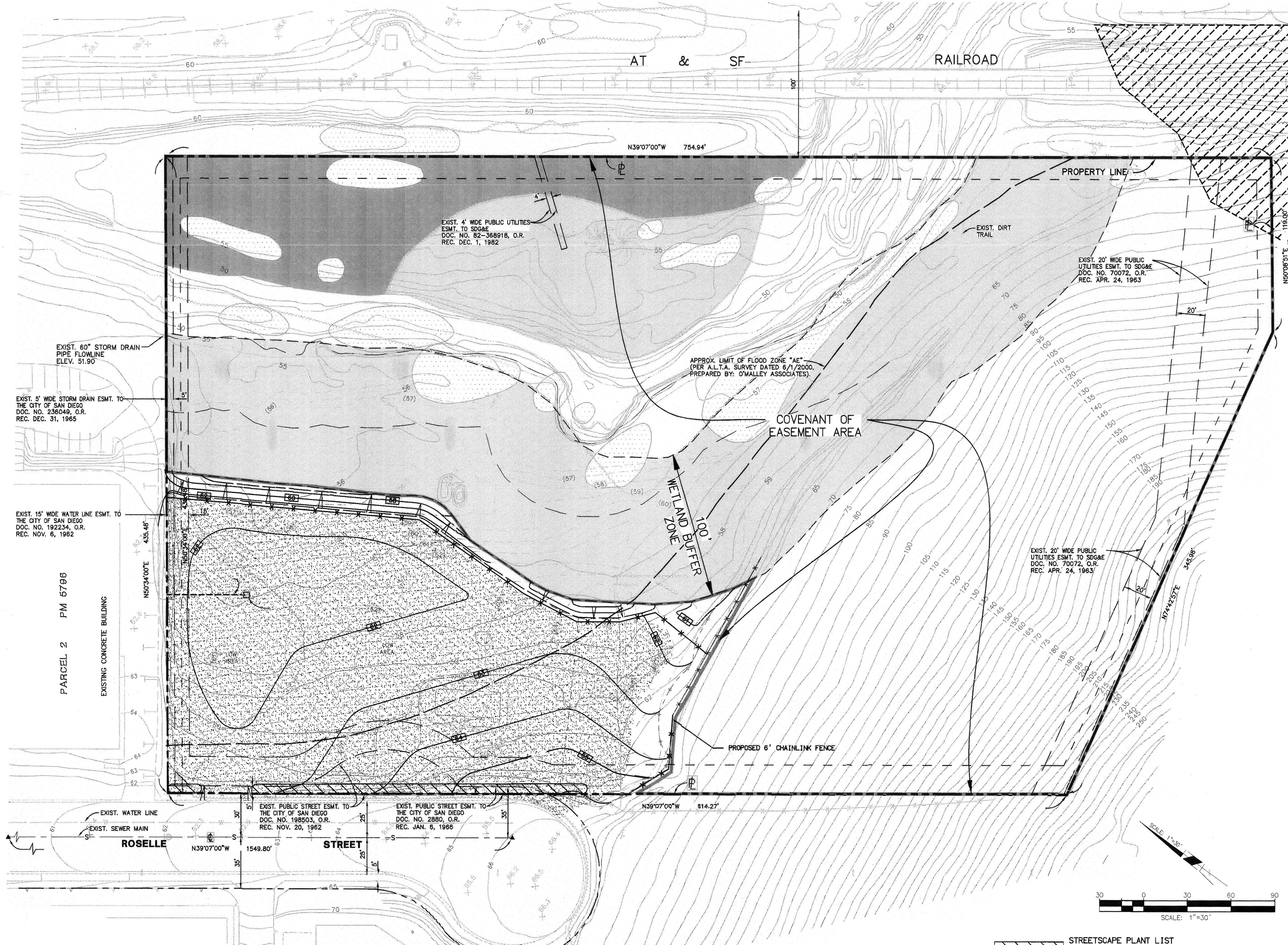

WETLAND ENHANCEMENT AREA

PLAN NOTES THE WETLAND ENHANCEMENT AREA HAS BEEN PLANNED TO MEET THE HABITAT COMPENSATION REQUIREMENTS FOR THE PROPOSED PROJECT, AS DESCRIBED IN THE BIOLOGICAL RESOURCES LETTER REPORT FOR THE PROJECT (DUDEK 2009). NATIVE PLANT SPECIES HAVE BEEN SELECTED CONSISTENT WITH SPECIES OCCURRING IN THE ADJACENT RIPARIAN WETLAND COMMUNITY. A CONCEPTUAL WETLAND MITIGATION PLAN HAS BEEN PREPARED, WHICH WILL DESCRIBE THE DETAILS AND SPECIFICATIONS FOR WETLAND ENHANCEMENT AREA. THE SITE WILL BE MAINTAINED AND MONITORED AS SPECIFIED IN THE CONCEPTUAL WETLAND MITIGATION PLAN.

WETLAND ENHANCEMENT AREA -- SOUTHERN WILLOW SCRUB PLANT PALETTE

SOUTHERN WILLOW SCRUB (SWS) ENHANCEMENT AREA CONTAINER PLANT PALETTE:
Assumed area: (0.42 ac. = 18,298 sq. ft.)

Botanical Name	Common Name	Average Spacing (Feet on Center)	Percent Composition	Container Size	Estimated Number of Plants
Container Plants					
Shrubs (Understory)					
<i>Artemisia douglasiana</i>	Douglas mugwort	4	3%	1 gallon	34
<i>Artemisia palmeri</i>	Palmer sagewort	4	5%	1 gallon	57
<i>Baccharis salicifolia</i>	Mulleet	6	5%	1 gallon	25
<i>Iva hayesiana</i>	San Diego marsh elder	4	4%	1 gallon	46
<i>Rosa californica</i>	California wild rose	4	3%	1 gallon	34
Trees (Overstory)					
Total Plants: 233					
Trees (Cuttings)					
<i>Salix lasiolepis</i>	Arroyo willow	2"		Cuttings/stakes	20
<i>Salix goodingii</i>	Black willow	3"		Cuttings/stakes	20
<i>Salix hindiana</i>	Narrow-leaved willow	2"		Cuttings/stakes	20
Total Cuttings: 60					
Hydroseed Mix A*					
	Min. % Purify/ % Germination			Lbs. Per Acre	
<i>Ambrosia psilostachya</i>	Western ragweed	20/30			3
<i>Artemisia douglasiana</i>	Mugwort	15/50			6
<i>Artemisia palmeri</i>	Palmer sagewort	20/50			5
<i>Isocoma menziesii</i>	Coast goldenbush	40/30			3
<i>Iva hayesiana</i>	San Diego marsh elder	30/50			6
<i>Lotus scoparius</i>	Deerweed	95/80			4
<i>Lupinus bicolor</i>	Pygmy leaved lupine	98/85			3
Total Lbs. Per Acre: 30					

* All hydroseed mixes shall include the seed mix indicated in lbs. per acre. Virgin wood cellulose fiber mulch at 2,500 lbs. per acre. Fertilizer (11-52-0) at 250 lbs. per acre, and binder at 100 lbs. per acre (when seasonally appropriate).

** All cuttings shall be placed along the creek bank.

*** PROJECT CONSULTANTS ***

PLANNER RBF CONSULTING CONTACT: CAROL CHASE 9755 CLAIREMONT MESA BLVD., #100 SAN DIEGO, CA 92124 TEL: (858) 614-5000 FAX: (858) 614-5080	CIVIL ENGINEER STEVENS CRESTO ENGINEERING, INC. CONTACT: MARK E STEVENS 9865 CHESAPEAKE DRIVE, SUITE 200 SAN DIEGO, CA 92123 TEL: (858) 694-5660 FAX: (858) 694-5661
---	---

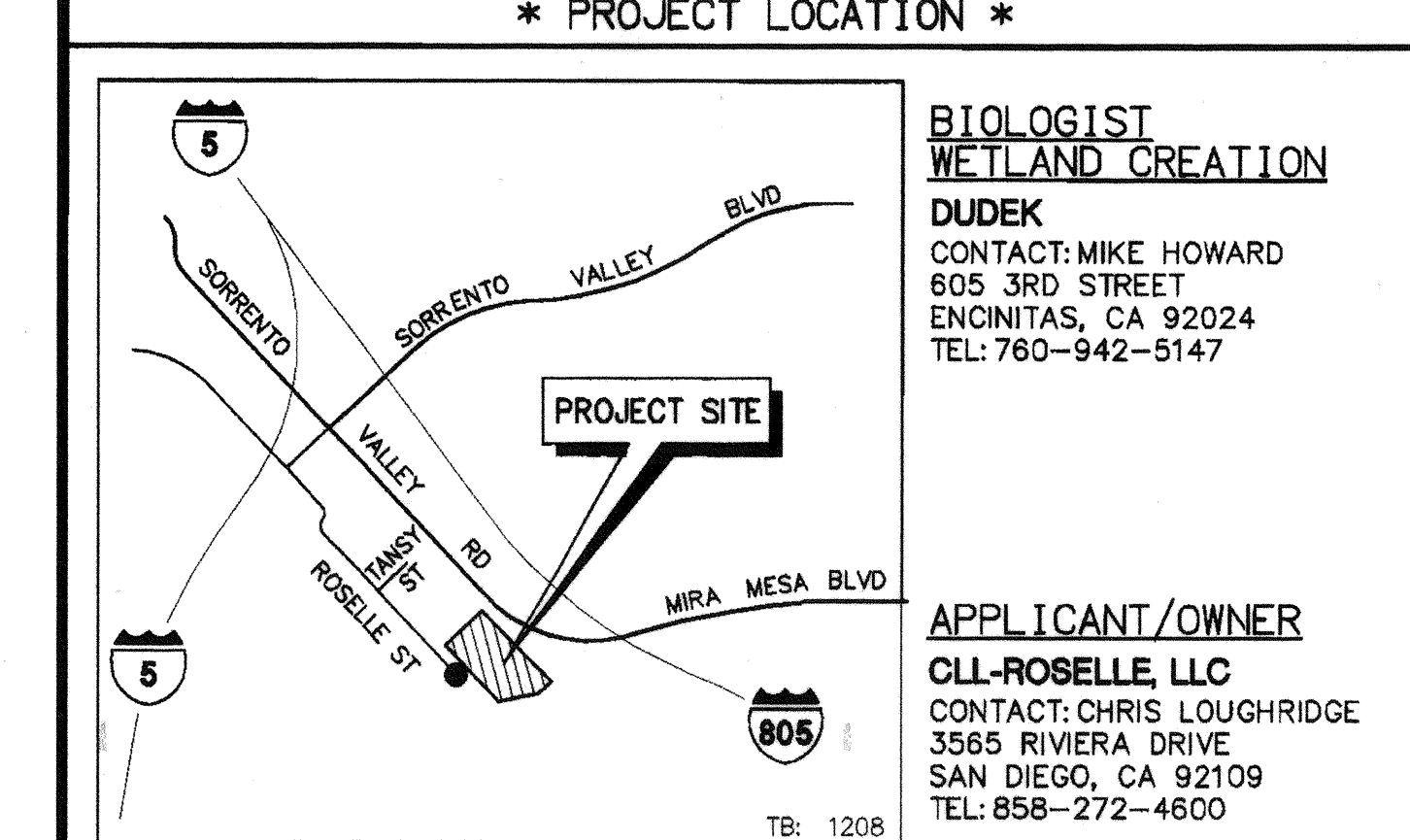

CCS 83 COORDINATE = 1905-6265
LAMBERT COORDINATE = 285-1705

Prepared By:
RBF CONSULTING
CONTACT PERSON: CAROL CHASE
9755 CLAIREMONT MESA BLVD., #100
SAN DIEGO, CA 92124
TEL: (858) 614-5000
FAX: (858) 810-1450

Project Address:
10325 ROSELLE STREET
SORRENTO VALLEY, CA 92121

Project Name:
ROSELLE STREET

Revision:

Revision 10:	
Revision 9:	
Revision 8:	
Revision 7:	
Revision 6:	
Revision 5:	
Revision 4:	08/12/09
Revision 3:	5/11/09
Revision 2:	11/25/08
Revision 1:	8/5/08

Original Date: 2/14/08

SHEET 6 OF 8
PTS# 133029

WETLAND BUFFER ZONE SEED MIX

COASTAL SAGE SCRUB HYDROSEED MIX (non-irrigated application):
WETLAND BUFFER ZONE - COASTAL SAGE SCRUB (100 FT WIDE)

Botanical Name	Common Name	#P/#G	Lbs./Acre
<i>Artemisia californica</i>	California sagebrush	15/60	4
<i>Encelia californica</i>	Coastal sunflower	40/60	2
<i>Eriogonum fasciculatum</i>	Flat-topped buckwheat	50/20	5
<i>Eschscholzia californica</i>	California poppy	98/80	4
<i>Isocoma menziesii</i>	Coastal goldenbush	40/30	2
<i>Lotus scoparius</i>	Deerweed	95/80	6
<i>Lupinus succulentus</i>	Arroyo lupine	98/85	2
<i>Nassella pulchra</i>	Purple needlegrass	90/80	4
<i>Plantago erecta</i>	Dot seed plantain	90/80	4
<i>Salvia mellifera</i>	Black sage	70/50	4
<i>Sisyrinchium bellum</i>	Blue eyed grass	95/75	3
		Total Lbs. Per Acre	40

* ALL HYDROSEED MIXES SHALL INCLUDE SEED MIX INDICATED IN LBS. PER ACRE, VIRGIN WOOD CELLULOSE FIBER MULCH AT 2,200 LBS. PER ACRE, FERTILIZER (11-52-0) AT 250 LBS. PER ACRE, AND BINDER AT 100 LBS. PER ACRE (WHEN SEASONALLY APPROPRIATE).

STREETSCAPE PLANT LIST
STREETSCAPE PLANT MATERIALS LIST

Species	Common Name	Container Size	Spacing
LOW GROWING SHRUBS, SUCH AS:			
<i>Arctostaphylos 'Sunset'</i>	Sunset Manzanita	1 gal.	3ft.
<i>Epilobium californicum</i>	California Fuchsia	1 gal.	2ft.
<i>Galvizia speciosum 'Firecracker'</i>	Island Bush Snap Dragon	1 gal.	3ft.
<i>Helianthemum scoparium</i>	Sun Rose	1 gal.	2ft.
<i>Salvia daveiandii</i>	Cleveland Sage	1 gal.	3ft.
<i>Salvia greggii</i>	Autumn Sage	1 gal.	3ft.
<i>Salvia munzii</i>	San Miguel Mtn. Sage	1 gal.	2ft.
<i>Trichostema lanatum</i>	Woolly Blue Curts	1 gal.	3ft.
<i>Viguiera lacinata</i>	San Diego Co. Viguiera	1 gal.	3ft.
GROUND COVERS, SUCH AS:			
<i>Ceanothus gr. 'hor. 'Yankee pt.'</i>	Yankee Point Ceanothus	1 gal.	3ft.
<i>Baccharis pilularis 'Twin Peaks'</i>	Dwarf Coyote Bush	1 gal.	2ft.
<i>Eriogonum parvifolium</i>	Coastal Buckwheat	1 gal.	2ft.
<i>Iva hayesiana</i>	San Diego Marsh Elder	1 gal.	3ft.
<i>Salvia mellifera 'Tera Seca'</i>	Tera Seca Sage	1 gal.	3ft.
FENCE VINE:			
<i>Island morning glory 'Anacapa Pink'</i>	<i>Calyptegia macrostegia</i>	1 gal.	5ft.

NOTE: 2 TO 3 SHRUB SPECIES AND 2 TO 3 GROUND COVER SPECIES WOULD BE SELECTED FROM THE ABOVE LISTS FOR PLANTING RAISED BERM AREA ALONG ROSELLE STREET.

ROSELLE STREET

SITE DEVELOPMENT PERMIT / COASTAL DEVELOPMENT PERMIT NEIGHBORHOOD DEVELOPMENT PERMIT

SCALE: 1"=30'

LEGEND

- PROJECT BOUNDARY
- EXISTING CONDITION (PRIOR TO UNAUTHORIZED FILL)
- UNAUTHORIZED FILL
- EXISTING CURB & GUTTER
- EXISTING 6FT CHAIN LINK FENCE
- 100 YR FLOOD PLAIN
- MULTIPLE HABITAT PLANNING AREA (MHPA)

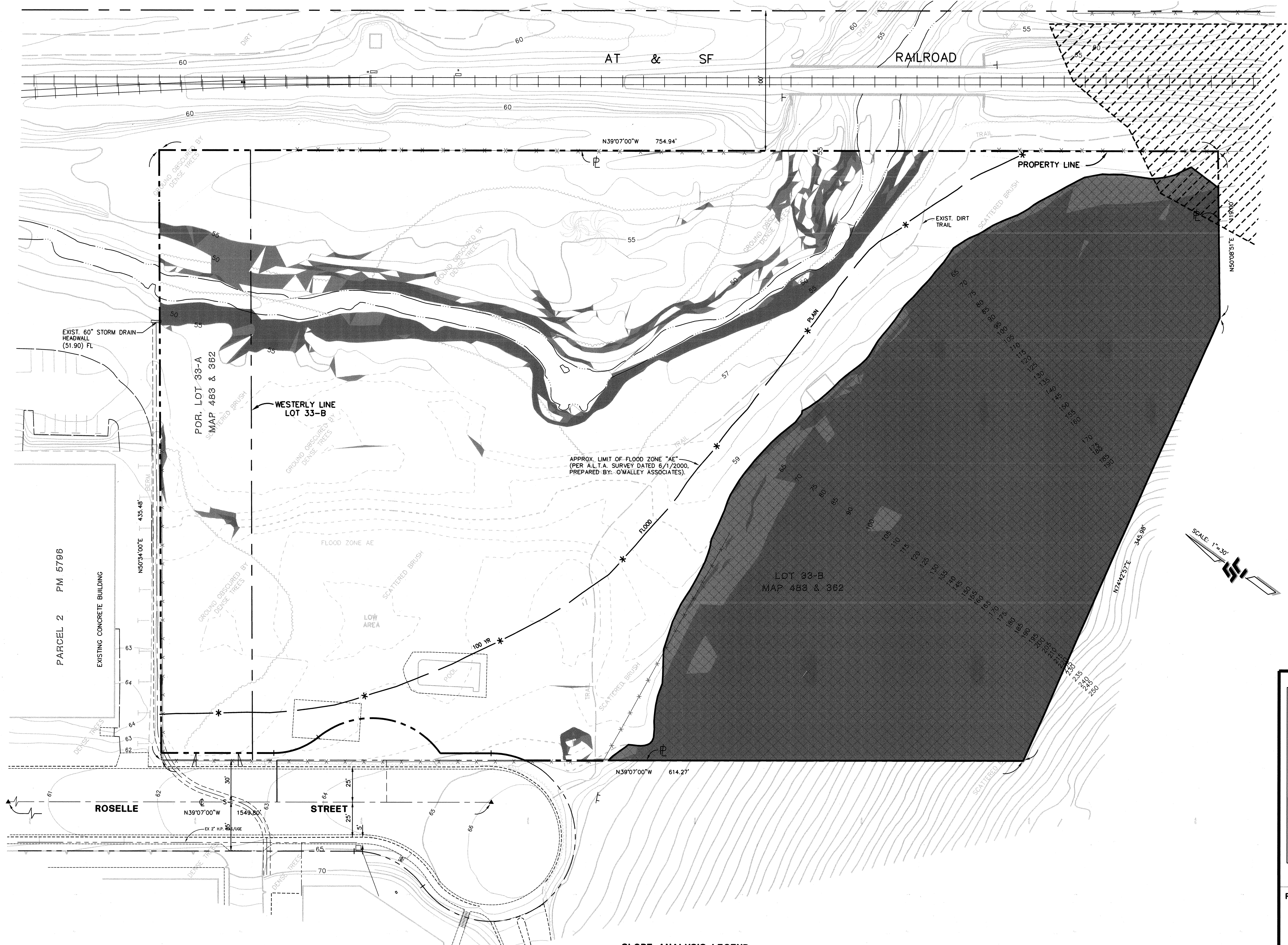

SCALE: 1"=30'

* PROJECT LOCATION *

APPLICANT/OWNER
CLL-ROSELLE, LLC
 CONTACT: CHRIS LOUGHRIDGE
 3565 RIVIERA DRIVE
 SAN DIEGO, CA 92109
 TEL: 858-272-4600

TB: 1208

SLOPE ANALYSIS LEGEND

RANGE	COLOR	AREA	PERCENT
LESS THAN 25%		4.30± AC.	61.1
25% UP TO 35%		0.26± AC.	3.7
35% AND GREATER		2.48± AC.	35.2
TOTAL SITE AREA		7.04 AC.	100%

ESL STEEP HILLSIDES

RANGE	COLOR	AREA	PERCENT OF SITE	PERCENT IMPACTED
25% AND GREATER, GREATER THAN 50 FOOT RISE		2.4± AC.	34%	0%

ENGINEER OF WORK

Mark E. Stevens 2/25/15
 MARK E. STEVENS
 P.C.E. 35502 DATE

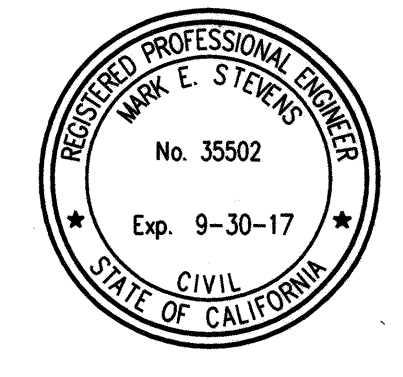

STEVENS-CRESTO ENGINEERING, INC.
 CIVIL ENGINEERS - PLANNERS - LAND SURVEYORS

9665 CHESAPEAKE DRIVE
 SUITE 200
 SAN DIEGO, CA 92123-1352

PHONE: 858.694.5660
 FAX: 858.694.5661
 www.sceengr.com

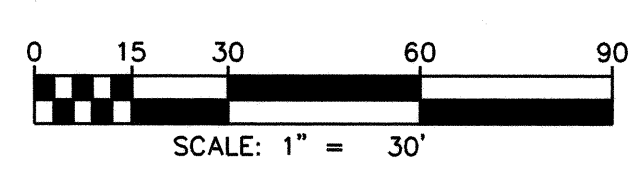

**CCS 83 COORDINATE = 1905-6265
 LAMBERT COORDINATE = 264-1705**

Prepared By:
 STEVENS CRESTO ENGINEERING
 9665 CHESAPEAKE DRIVE
 SUITE 200
 SAN DIEGO, CA 92123
 TEL (858) 694-5660
 FAX (858) 694-5661

Project Address:
 10325 ROSELLE STREET
 SORRENTO VALLEY, CA 92121

Project Name:
ROSELLE STREET

Sheet Title:
SLOPE ANALYSIS

Revision 10:	_____
Revision 9:	_____
Revision 8:	_____
Revision 7:	_____
Revision 6:	02/26/15
Revision 5:	08/12/09
Revision 4:	05/11/09
Revision 3:	04/21/09
Revision 2:	11/25/08
Revision 1:	08/05/08
Original Date:	02/14/08
Sheet	7 of 8
PTS#	133029

C-7

INITIAL STUDY CHECKLIST

1. Project Title/Project number: 10325 Roselle Street/Project No. 150566
2. Lead agency name and address: City of San Diego, Planning Department, 9485 Aero Drive, MS 413, San Diego, CA 92123
3. Contact person and phone number: Myra Herrmann, Senior Planner. (619) 446-5372
4. Project location: 10325 Roselle Street on an approximately 7.0-acre site in the southern portion of the Torrey Pines Community Planning Area within Sorrento Valley. Carroll Canyon Creek passes through the northwest portion of the property becoming Soledad Canyon within the property boundary. The project site is located on the Federal Emergency Management Agency's (FEMA) Flood Insurance Rate Map (FIRM), Community Panel No. 06073C1339G, dated May 16, 2012, for the City of San Diego, California, updated and revised pursuant to Letter of Map Revision (LOMR) Determination Document effective July 24, 2017 and revised the effective National Flood Insurance Program (NFIP) map panel (Panel 1339 of 2375) associated with the project site. A small area in the southeastern corner of the property is mapped within the City's Multi-Habitat Planning Area (MHPA). The project site is also located in the Accident Potential Zone 2 for MCAS Miramar and the 60 dB CNEL contour as indicated in the adopted ALUCP for MCAS Miramar.
5. Project Applicant/Sponsor's name and address: CLL-Roselle, LLC / 3565 Riviera Drive, San Diego, CA 92109 / (858) 272-4400.
6. General Plan designation: Industrial
7. Zoning: IL-3-1 (industrial), Coastal Overlay Zone (Appealable & Non-Appealable Area 1).
8. Description of project (Describe the whole action involved, including but not limited to, later phases of the project, and any secondary, support, or off-site features necessary for its implementation.): Site Development Permit (SDP) and Coastal Development Permit (CDP) to allow for the remediation of impacts associated with a grading violation that occurred on the site by a former tenant which resulted in the placement of unauthorized fill material impacting biological, archaeological and tribal cultural resources. The project site contains sensitive biological resources, a designated important archaeological/tribal cultural resource (HRB Site #924), and steep hillsides. As part of the site remediation, the project will recontour the fill material to create a 100-foot native-landscaping buffer to protect the wetlands, and build a pad that would be suitable for an equipment, materials, or vehicle storage yard, consistent with the community plan land use (Industrial) and zoning (IL-3-1) designations. A mobile office trailer will be placed close to the existing water and sewer facilities to minimize ground disturbance. Minor and routine vehicle maintenance would be allowed within a small area of the project site; however, the storage of inoperable vehicles or hazardous/toxic materials will not be allowed on this site. The pad area and access driveway will be surfaced with decomposed granite and all storm water runoff will be treated onsite and conveyed through a newly constructed storm drain, and into the existing storm drain system along the northwest property line on Roselle Street. The approximately 1.5-acre pad area would be fenced, and an open space easement placed over the balance of the site to protect the sensitive biological/wetland resources. A landscape plan, designed and prepared in consultation with the project biologist, archaeologist and Native American Kumeyaay monitor is proposed along the Roselle Street frontage to provide a native plant palette with minimal ground-disturbing impacts.

The initial unauthorized grading and fill placement resulted in impacts, both on-site and off-site to upland and wetland habitats; however, over the span of time it has taken to complete the project and environmental review process, the habitat within and outside of the impact areas have improved with over 30% native cover observed. As such, habitat acreages were reevaluated for the project impact areas and consist of 1.32 acres of upland habitat (Baccharis-dominated scrub, disturbed coastal sage scrub, disturbed/ruderal, Eucalyptus woodland, and non-native grassland), and impacts to a locally designated important archaeological/tribal cultural resource site. Impacts to biological resources requires mitigation in the form of onsite conservation of 5.32 acres of land to be placed into the City's MHPA, enhancement of 0.42-acre of southern willow scrub, maintenance and seeding of the wetland buffer zone (approximately 1.54 acres), weed and exotic species removal adjacent to the wetlands enhancement area, and implementation of a five-year maintenance and monitoring program to meet performance standards. Although the unauthorized fill material that was placed on the site will remain in place acting as a cap to protect the important archaeological and tribal cultural resources, pursuant to the City's Land Development Code (LDC) Historical Resources Regulation and associated Land Development Manual (LDM) Historical Resources Guidelines, some recontouring will be required to create the wetland buffer and pad area, and fencing to provide additional security to the site to protect the resources. Site grading/recontouring of the fill material will require implementation of an Archaeological Data Recovery Program and subsequent monitoring of all ground-disturbing activities by a qualified archaeologist and Native American Kumeyaay cultural consultant. The site grading/contouring has been designed to avoid further impacts to sensitive biological, archaeological and tribal cultural resources, and to avoid encroachment into the steep hillsides.

9. Surrounding land uses and setting: The project site is vacant and surrounded by industrial land uses, open space dominated by wetland and upland habitats, and a storm water conveyance channel – Carroll Canyon Creek.
10. Other public agencies whose approval is required (e.g., permits, financing approval, or participation agreement.): None.
11. Have California Native American tribes traditionally and culturally affiliated with the project area requested consultation pursuant to Public Resources Code (PRC) section 21080.3.1? If so, is there a plan for consultation that includes, for example, the determination of significance of impacts to tribal cultural resources, procedures regarding confidentiality, etc.? Tribal consultation was conducted on October 2017 with representatives from the Iipay Nation of Santa Ysabel and the Jamul Indian Village. Information was discussed with the consulting parties regarding significance of impacts to tribal cultural resources and confidentiality of site information. Consultation included discussion of the project scope/plans, review of archaeological site capping proposal, and other relevant project information regarding associated with the mitigation program. Consultation concluded with all parties in agreement regarding the archaeological data recovery program and associated monitoring with a requirement and recommendation for Native American Kumeyaay participation during all phases of the mitigation program within the project area to ensure the appropriate treatment and protection of tribal cultural resources.

Note: Conducting consultation early in the CEQA process allows tribal governments, lead agencies, and project proponents to discuss the level of environmental review, identify and address potential adverse impacts to tribal cultural resources, and reduce the potential for delay and conflict in the environmental review process. (See Public Resources Code section 21083.3.2.) Information may also be available from the California Native American Heritage Commission's Sacred Lands File per Public Resources Code section 5097.96 and the California Historical Resources Information System administered by the California Office of Historic Preservation. Please also note that Public Resources Code section 21082.3(c) contains provisions specific to confidentiality.

ENVIRONMENTAL FACTORS POTENTIALLY AFFECTED:

The environmental factors checked below would be potentially affected by this project, involving at least one impact that is a "Potentially Significant Impact" as indicated by the checklist on the following pages.

- | | | |
|--|--|---|
| <input type="checkbox"/> Aesthetics | <input type="checkbox"/> Greenhouse Gas Emissions | <input type="checkbox"/> Population/Housing |
| <input type="checkbox"/> Agriculture and Forestry Resources | <input type="checkbox"/> Hazards & Hazardous Materials | <input type="checkbox"/> Public Services |
| <input type="checkbox"/> Air Quality | <input type="checkbox"/> Hydrology/Water Quality | <input type="checkbox"/> Recreation |
| <input type="checkbox"/> Biological Resources | <input type="checkbox"/> Land Use/Planning | <input type="checkbox"/> Transportation/Traffic |
| <input checked="" type="checkbox"/> Cultural Resources | <input type="checkbox"/> Mineral Resources | <input checked="" type="checkbox"/> Tribal Cultural Resources |
| <input type="checkbox"/> Utilities/Service System | <input type="checkbox"/> Geology/Soils | <input type="checkbox"/> Noise |
| <input checked="" type="checkbox"/> Mandatory Findings of Significance | | |

DETERMINATION: (To be completed by Lead Agency)

On the basis of this initial evaluation:

- The proposed project COULD NOT have a significant effect on the environment, and a NEGATIVE DECLARATION will be prepared.
- Although the proposed project could have a significant effect on the environment, there will not be a significant effect in this case because revisions in the project have been made by or agreed to by the project proponent. A MITIGATED NEGATIVE DECLARATION will be prepared.
- The proposed project MAY have a significant effect on the environment, and an ENVIRONMENTAL IMPACT REPORT is required.
- The proposed project MAY have a “potentially significant impact” or “potentially significant unless mitigated” impact on the environment, but at least one effect (a) has been adequately analyzed in an earlier document pursuant to applicable legal standards, and (b) has been addressed by mitigation measures based on the earlier analysis as described on attached sheets. An ENVIRONMENTAL IMPACT REPORT is required.
- Although the proposed project could have a significant effect on the environment, because all potentially significant effects (a) have been analyzed adequately in an earlier EIR or (MITIGATED) NEGATIVE DECLARATION pursuant to applicable standards, and (b) have been avoided or mitigated pursuant to that earlier EIR or (MITIGATED) NEGATIVE DECLARATION, including revisions or mitigation measures that are imposed upon the proposed project, nothing further is required.

Issue	Potentially Significant Impact	Less Than Significant with Mitigation Incorporated	Less Than Significant Impact	No Impact
-------	--------------------------------	--	------------------------------	-----------

I) AESTHETICS – Would the project:

- a) Have a substantial adverse effect on a scenic vista?

The proposed project would not substantially affect a scenic vista since it would be located primarily within an existing vacant 6.81-acre private parcel on a cul-de-sac in an industrially zoned area of Sorrento Valley. A portion of the project site includes a steep hillside with coastal sage scrub habitat that is within the City’s Multi-Habitat Planning Area but would not be affected by the proposed use, or on-site mitigation/habitat conservation. The project as proposed would improve the visual quality of the area by removing overgrown, invasive, non-native plant species and damaged fencing, recontour unauthorized fill soil and implement a habitat restoration plan. Once site improvements have been completed, new fencing will be installed to protect both the archaeological site and the restoration areas from potential damage.

- b) Substantially damage scenic resources, including but not limited to, trees, rock outcroppings, and historic buildings within a state scenic highway?

The project site is currently vacant, and once improved would not result in direct impacts to scenic resources such as those listed above. Additionally, the project site is not located within a state scenic highway where historic buildings could be affected.

- c) Substantially degrade the existing visual character or quality of the site and its surroundings?

Please see I. a.

- d) Create a new source of substantial light or glare that would adversely affect day or nighttime views in the area?

The proposed project would not utilize construction materials that are highly reflective, and project work would occur at or slightly above ground level. Project implementation would not create a new source of light or glare that would adversely affect day or nighttime views in the area.

II) AGRICULTURAL AND FOREST RESOURCES: In determining whether impacts to agricultural resources are significant environmental effects, lead agencies may refer to the California Agricultural Land Evaluation and Site Assessment Model (1997) prepared by the California

Issue	Potentially Significant Impact	Less Than Significant with Mitigation Incorporated	Less Than Significant Impact	No Impact
-------	--------------------------------	--	------------------------------	-----------

Department of Conservation as an optional model to use in assessing impacts on agriculture and farmland. In determining whether impacts to forest resources, including timberland, are significant environmental effects, lead agencies may refer to information compiled by the California Department of Forestry and Fire Protection regarding the state's inventory of forest land, including the Forest and Range Assessment Project and the Forest Legacy Assessment project; and forest carbon measurement methodology provided in Forest Protocols adopted by the California Air Resources Board. – Would the project:

- a) Converts Prime Farmland, Unique Farmland, or Farmland of Statewide Importance (Farmland), as shown on the maps prepared pursuant to the Farmland Mapping and Monitoring Program of the California Resources Agency, to non-agricultural use?

The site of the proposed project is not classified as farmland by the Farmland Mapping and Monitoring Program (FMMP). Similarly, land surrounding the proposed project is not classified as farmland by the FMMP. Therefore, the proposed project would not convert farmland to non-agricultural uses. The site and surrounding zoning designation is Industrial (IL-3-1) and is also adjacent to City-owned open space and a rail corridor where farming activities do not exist.

- b) Conflict with existing zoning for agricultural use, or a Williamson Act Contract?

Please see II.a

- c) Conflict with existing zoning for, or cause rezoning of, forest land (as defined in Public Resources Code section 1220(g)), timberland (as defined by Public Resources Code section 4526), or timberland zoned Timberland Production (as defined by Government Code section 51104(g))?

The project would not conflict with existing zoning for, or cause rezoning of, forest land, timberland or timberland zones Timberland Production. No designated forest land or timberland occur onsite. The project is consistent with the General Plan and community

Issue	Potentially Significant Impact	Less Than Significant with Mitigation Incorporated	Less Than Significant Impact	No Impact
-------	--------------------------------	--	------------------------------	-----------

plan industrial land use designation for the site. Therefore, the proposed project would not conflict with existing zoning for forest land and no impacts would result.

- | | | | | |
|--|--------------------------|--------------------------|--------------------------|-------------------------------------|
| d) Result in the loss of forest land or conversion of forest land to non-forest use? | <input type="checkbox"/> | <input type="checkbox"/> | <input type="checkbox"/> | <input checked="" type="checkbox"/> |
|--|--------------------------|--------------------------|--------------------------|-------------------------------------|

Please refer to response II(c) above. The proposed project is located on a vacant private parcel in an industrial zoned area. Additionally, the project would not contribute to the conversion of any forested land to non-forest use, as surrounding land uses are built out. No impacts would result.

- | | | | | |
|--|--------------------------|--------------------------|--------------------------|-------------------------------------|
| e) Involve other changes in the existing environment, which, due to their location or nature, could result in conversion of Farmland to non-agricultural use or conversion of forest land to non-forest use? | <input type="checkbox"/> | <input type="checkbox"/> | <input type="checkbox"/> | <input checked="" type="checkbox"/> |
|--|--------------------------|--------------------------|--------------------------|-------------------------------------|

Refer to response II (a) and II (c), above. No existing agricultural uses are located in proximity to the project site that could be affected by the proposed project.

III. AIR QUALITY – Where available, the significance criteria established by the applicable air quality management or air pollution control district may be relied on to make the following determinations – Would the project:

- | | | | | |
|---|--------------------------|--------------------------|-------------------------------------|--------------------------|
| a) Conflict with or obstruct implementation of the applicable air quality plan? | <input type="checkbox"/> | <input type="checkbox"/> | <input checked="" type="checkbox"/> | <input type="checkbox"/> |
|---|--------------------------|--------------------------|-------------------------------------|--------------------------|

The San Diego Air Pollution Control District (SDAPCD) and San Diego Association of Governments (SANDAG) are responsible for developing and implementing the clean air plan for attainment and maintenance of the ambient air quality standards in the San Diego Air Basin (SDAB). The County Regional Air Quality Strategy (RAQS) was initially adopted in 1991, and is updated on a triennial basis (most recently in 2009). The RAQS outlines the SDAPCD’s plans and control measures designed to attain the state air quality standards for ozone (O3). The RAQS relies on information from the California Air Resources Board (CARB) and SANDAG, including mobile and area source emissions, as well as information regarding projected growth in San Diego County and the cities in the county, to project future emissions and then determine the strategies necessary for the reduction of emissions through regulatory controls. CARB mobile source emission projections and SANDAG growth projections are based on population, vehicle trends, and land use plans developed by San Diego County and the cities in the county as part of the development of their general plans.

Issue	Potentially Significant Impact	Less Than Significant with Mitigation Incorporated	Less Than Significant Impact	No Impact
-------	--------------------------------	--	------------------------------	-----------

The RAQS relies on SANDAG growth projections based on population, vehicle trends, and land use plans developed by the cities and by the county as part of the development of their general plans. As such, projects that propose development that is consistent with the growth anticipated by local plans would be consistent with the RAQS. However, if a project proposes development that is greater than that anticipated in the local plan and SANDAG's growth projections, the project might be in conflict with the RAQS and may contribute to a potentially significant cumulative impact on air quality.

The project would require grading to re-contour unauthorized placement of fill on the site which resulted in impacts to biological resources. The project would also implement a habitat restoration plan, minor trenching for construction of a drainage system and connection to existing utilities requiring the use of small equipment for a short duration. The use of a backhoe, Bobcat, and dump truck for debris removal during the proposed project could increase the amount of harmful pollutants entering the air basin. However, emissions during construction-related activities would be temporary and limited to the project site. Habitat restoration would not require the long-term use of heavy machinery; however, removal of non-native exotic trees and large shrubs would require the use of chain saws. All other site work would be conducted by hand, and only require travel to the site by one or two vehicles during plant installation and maintenance/monitoring. Therefore, the project would be consistent at a subregional level with the underlying growth forecasts in the RAQS, and would not obstruct implementation of the RAQS. As such, no impacts would result.

- | | | | | | |
|--|--------------------------|--------------------------|--------------------------|--------------------------|-------------------------------------|
| b) Violate any air quality standard or contribute substantially to an existing or projected air quality violation? | <input type="checkbox"/> | <input type="checkbox"/> | <input type="checkbox"/> | <input type="checkbox"/> | <input checked="" type="checkbox"/> |
|--|--------------------------|--------------------------|--------------------------|--------------------------|-------------------------------------|

Please see III.a.

- | | | | | | |
|---|--------------------------|--------------------------|--------------------------|--------------------------|-------------------------------------|
| c) Result in a cumulatively considerable net increase of any criteria pollutant for which the project region is non-attainment under an applicable federal or state ambient air quality standard (including releasing emissions which exceed quantitative thresholds for ozone precursors)? | <input type="checkbox"/> | <input type="checkbox"/> | <input type="checkbox"/> | <input type="checkbox"/> | <input checked="" type="checkbox"/> |
|---|--------------------------|--------------------------|--------------------------|--------------------------|-------------------------------------|

Short-Term (Construction) Emissions. Construction-related activities are temporary, short-term sources of air emissions. Sources of construction-related air emissions include fugitive dust from grading activities; construction equipment exhaust; construction-related trips by workers, delivery trucks, and material-hauling trucks; and construction-related power

Issue	Potentially Significant Impact	Less Than Significant with Mitigation Incorporated	Less Than Significant Impact	No Impact
-------	--------------------------------	--	------------------------------	-----------

consumption. Variables that factor into the total construction emissions potentially generated include the level of activity, length of construction period, number of pieces and types of equipment in use, site characteristics, weather conditions, number of construction personnel, and the amount of materials to be transported on or offsite.

Fugitive dust emissions are generally associated with land-clearing and grading operations. As described above, implementation of the project and associated construction-related activities could temporarily increase the emissions of dust and other pollutants during debris and tree/shrub removal activities. Construction operations would include standard measures as required by City of San Diego grading permit to limit potential air quality impacts. Therefore, impacts associated with fugitive dust are considered less than significant, and would not violate an air quality standard or contribute substantially to an existing or projected air quality violation. No mitigation measures are required.

Long-Term (Operational) Emissions. Long-term air emission impacts are those associated with stationary sources and mobile sources related to any change caused by a project. The project would produce minimal stationary sources emissions. The project is compatible with the surrounding industrial development and is permitted by the General Plan and community plan. Based on the industrial land use designation for the site which allows equipment, materials, or vehicle storage yard, project emissions over the long-term are not anticipated to violate any air quality standard or contribute substantially to an existing or projected air quality violation. Therefore, the proposed project would not result in a cumulatively considerable net increase of any criteria pollutant for which the project region is non-attainment under applicable federal or state ambient air quality standards. Impacts would be less than significant and no mitigation measures are required.

- d) Expose sensitive receptors to substantial pollutant concentrations?

As described above, construction operations could temporarily increase the emissions of dust and other pollutants. However, construction emissions would be temporary and short-term in duration; implementation of Best Management Practices (BMPs) would reduce potential impacts related to construction activities to a less than significant level. Therefore, the project would not result in a cumulatively considerable net increase of any criteria pollutant for which the project region is a nonattainment under applicable federal or state ambient air quality standards. Impacts would be less than significant.

- e) Create objectionable odors affecting a substantial number of people?

Short-term (Construction)

Odors would be generated from vehicles and/or equipment exhaust emissions during construction of the project. Odors produced during construction would be attributable to concentrations of unburned hydrocarbons from tailpipes of construction equipment and architectural coatings. Such odors are temporary and generally occur at magnitudes that would not affect a substantial number of people. Therefore, impacts would be less than significant.

Long-term (Operational)

Issue	Potentially Significant Impact	Less Than Significant with Mitigation Incorporated	Less Than Significant Impact	No Impact
-------	--------------------------------	--	------------------------------	-----------

Typical long-term operational characteristics of the project are not associated with the creation of such odors nor anticipated to generate odors affecting a substantial number of people. The project would require use of small equipment such as a backhoe, Bobcat, dump truck, and other construction or habitat restoration crew vehicles that could generate odors associated with fuel combustion to facilitate ultimate use of the site for equipment, materials or vehicle storage which would not allow vehicle maintenance on site, storage of non-operable vehicles, or hazardous/toxic materials. These uses are not typically associated with the creation of odors nor are they anticipated to generate odors affecting a substantial number or people. Therefore, project operations would result in less than significant impacts.

IV. BIOLOGICAL RESOURCES – Would the project:

- a) Have substantial adverse effects, either directly or through habitat modifications, on any species identified as a candidate, sensitive, or special status species in local or regional plans, policies, or regulations, or by the California Department of Fish and Game or U.S. Fish and Wildlife Service?

The proposed project involves the removal/recontouring of unauthorized fill placed in the regularity floodway on the project site, and construction of a new concrete pad for mobile trailer placement, new drainage system, utility connections and habitat restoration on approximately 1.32-acres of a 6.81-acre vacant parcel. Site grading for the proposed equipment storage yard would impact previously graded habitat in the northwest corner of the parcel. This area was the subject of unauthorized grading and placement of fill within a regulatory floodway which impacted onsite habitat and an important archaeological site/tribal cultural resource resulting in a violation of the Environmentally Sensitive Lands Regulation (ESL-biology/wetlands/floodway) and Historical Resources Regulation (Archaeology/Tribal Cultural Resources) of the Land Development Code (LDC) in 2001. As such, the applicant was required to submit an application to the city to correct the code violation for habitat impacts, effects on the important archaeological/tribal cultural resource site, and to develop a plan for avoidance, remediation, restoration and mitigation of direct impacts. The proposed project includes a 100-foot buffer that would further avoid impacting the section of Carroll Canyon Creek that runs along the northeastern section of the parcel. The proposed project would impact a total of 1.32-acres of habitat.

In 2007, Dudek performed two site surveys to map habitats and biological resources on-site. In the 2009 resubmittal, a conceptual wetlands restoration plan was included to address mitigation for direct impacts to wetlands from the unauthorized grading activities. In 2015, REC revisited the site to confirm the past habitat mapping and found substantial changes to on-site habitats. According to the Biology Letter Report updated by REC, Consultants, Inc. in 2018, the Baccharis-dominated Scrub and disturbed Diegan Coastal Sage Scrub are considered Tier II (uncommon uplands) habitats, even though the Diegan Coastal Sage Scrub is moderately to highly disturbed;

Issue	Potentially Significant Impact	Less Than Significant with Mitigation Incorporated	Less Than Significant Impact	No Impact
-------	--------------------------------	--	------------------------------	-----------

and Non-Native Grassland is considered a Tier IIIB (common uplands) habitat. Impacts to each of these habitats would require mitigation as shown in Table 1, below. Southern Willow Scrub is considered a wetland and would require mitigation if impacted; however, the proposed Project has been designed to avoid any portion of this habitat and will maintain a 100-foot buffer from the wetland. Therefore, nearly all of the on-site Palmer's sagewort would not be impacted.

The REC update report also indicates that while the habitat within the impact area has improved in quality, the habitat outside of the impact area has improved as well. The steep north-facing hillside on the southernmost portion of the site can no longer be considered Ruderal, as well over 30% native cover was observed. Furthermore, at the southeastern corner of the parcel 0.05-acre of the on-site hillside is covered by the Multi-Habitat Planning Area (MHPA). By placing the rest of the hillside into open space, along with the other areas outside of the impact area, it would have connectivity to the MHPA and thus would be more valuable than if it were an isolated patch of habitat. Considering that the steep hillside consists of uncommon soil, has good cover by desirable native vegetation, and has connectivity to the MHPA, on-site preservation of the remaining habitat areas (~5.32-acres) would be placed in open space to mitigate for development-related impacts, and is more than sufficient to meet the project-related mitigation requirements and those associated with the initial unauthorized grading violation.

Table 1. Project Impacts and Mitigation Requirements

Vegetation Community/Land Cover Category	Existing On-Site (Acres)	Project Impact On-site (Acres)	Project Impact Off-site (Acres)	Project Impact Total (Acres)	Mitigation Ratio	Mitigation Required (Acres)
Baccharis-dominated	1.12	0.54	0.06	0.60	1.5:1	0.90
Disturbed Coastal Sage Scrub	2.14	0.38	0.00	0.38	1.5:1	0.57
Disturbed Southern	1.59	0.00	0.00	0.00	4:1	0.00
Disturbed/Ruderal	1.28	0.08	< 0.01	0.08	0:1	0.00
Eucalyptus	0.35	0.19	< 0.01	0.19	0:1	0.00
Non-native	0.33	0.07	0.00	0.07	1:1	0.07
TOTAL	6.81	1.26	0.06	1.32		1.54

In addition to the above project-related mitigation, the following Environmental Protection Measures and Project Design Features have been incorporated into the project to ensure compliance with the City's MHPA Land Use Adjacency Guidelines described in Section 1.4.3 of the City of San Diego MSCP Subarea Plan (City of San Diego, 1997) and avoidance additional impacts:

- Although the proposed Project will avoid wetlands, the applicant will be required to implement the wetland habitat restoration plan for previous impacts to wetlands as

Issue	Potentially Significant Impact	Less Than Significant with Mitigation Incorporated	Less Than Significant Impact	No Impact
<p>described in the previous Biology Reports prepared for the original project submittal (Dudek 2009a, 2009b).</p> <ul style="list-style-type: none"> All clearing and grubbing of vegetation and/or grading will occur outside the avian breeding season (February 1 to September 15, or sooner if a qualified biologist demonstrates to the satisfaction of the wildlife agencies that all nesting is complete). If construction (other than vegetation clearing and grubbing) must occur during the breeding season, pre-construction surveys should be performed by a qualified biologist within 10 calendar days prior to the start of construction to determine the presence or absence of nesting birds on-site and special-status birds within 300 feet (500 feet for raptors) of the impact area. If nesting birds are detected, the City and Wildlife Agencies will be contacted to discuss the potential impact minimization measures to be implemented. <p>b) Have a substantial adverse effect on any riparian habitat or other community identified in local or regional plans, policies, and regulations or by the California Department of Fish and Game or U.S. Fish and Wildlife Service?</p>	□	☒	□	□

Please see IV.a above. Because this site is in the Coastal Overlay Zone, the California Coastal Act and Coastal Commission regulations apply, specifically those applying to ESHA. The California Coastal Act, Section 30107.5, defines an Environmentally Sensitive Area as “any area in which plant or animal life or their habitats are either rare or especially valuable because of their special nature or role in an ecosystem and which could be easily disturbed or degraded by human activities and developments”. In order to determine if an area constitutes an ESHA, the Coastal Commission determines if the following criteria are met:

- 1) There are rare species or habitat in the subject area;
- 2) There are especially valuable species or habitats in the area, which is determined based on:
 - a. whether any species or habitat that is present has a special nature, OR
 - b. whether any species or habitat that is present has a special role in the ecosystem

As coastal sage scrub is a Tier II habitat, it is considered an uncommon upland rather than rare. Because the coastal sage scrub on-site is disturbed and contains patches of highly invasive species such as pampas grass, stinkwort (*Dittrichia graveolens*) and Russian-thistle, it is unlikely to support rare or especially valuable species. No special-status species were observed in or adjacent to the impact area during the most recent site visit and Dudek only reported observing one juvenile orange-throated whiptail (*Aspidoscelis hyperythra*) between riparian vegetation and the steep hillside, on the opposite side of the site from the impact area. Other special-status species that were determined to have a moderate or high potential to occur would only use the riparian habitat or adjacent hillside, which is not being impacted. Even if orange-throated whiptail is present in the disturbed coastal sage scrub that would be impacted, it is relatively widespread and should not be considered rare or especially valuable, regardless of its status as a State Species of Special

Issue	Potentially Significant Impact	Less Than Significant with Mitigation Incorporated	Less Than Significant Impact	No Impact
-------	--------------------------------	--	------------------------------	-----------

Concern. Neither orange-throated whiptail nor the disturbed coastal sage scrub area is likely to have a special role in the ecosystem. Due to the above reasons, the impacted area on-site should not be considered an ESHA.

Approximately 0.05 acres in the southeastern corner of the project site is located within the City's Multi-Habitat Planning Area (MHPA) and consists mainly of disturbed/ruderal habitat. According to the updated biology report, this area does not support sensitive species identified or listed in local or regional plans, policies or regulations; however, other areas of the project site contain sensitive upland and wetland habitat, as well as sensitive species such as the Yellow-breasted chat and Yellow warbler, and Palmer's sagewort in the proposed on-site wetland buffer area. Impacts to upland and wetland habitat resulted from previous unauthorized grading and fill placement activities included clearing of vegetation and minor grading to flatten the soil in the northwestern portion of the property up to Carroll Canyon Creek requiring mitigation in accordance with CEQA, through issuance of a Site Development Permit pursuant to the City's Land Development Code, Environmentally Sensitive Lands Regulation.

Additionally, the proposed site improvements will avoid the adjacent riparian corridor and as such, will not impact wetland species within the creek. Mitigation for impacts resulting from the previous unauthorized grading will involve, enhancement, restoration/revegetation, and maintenance monitoring to ensure plant establishment. The project also includes creation of a 100-foot wetland buffer from the proposed equipment storage yard area.

- | | | | | |
|---|--------------------------|-------------------------------------|--------------------------|--------------------------|
| <p>c) Have a substantial adverse effect on federally protected wetlands as defined by Section 404 of the Clean Water Act (including but not limited to marsh, vernal pool, coastal, etc.) through direct removal, filling, hydrological interruption, or other means?</p> | <input type="checkbox"/> | <input checked="" type="checkbox"/> | <input type="checkbox"/> | <input type="checkbox"/> |
|---|--------------------------|-------------------------------------|--------------------------|--------------------------|

Please see IV.a above.

- | | | | | |
|---|--------------------------|--------------------------|-------------------------------------|--------------------------|
| <p>d) Interfere substantially with the movement of any native resident or migratory fish or wildlife species or with established native resident or migratory wildlife corridors, or impede the use of native wildlife nursery sites?</p> | <input type="checkbox"/> | <input type="checkbox"/> | <input checked="" type="checkbox"/> | <input type="checkbox"/> |
|---|--------------------------|--------------------------|-------------------------------------|--------------------------|

The proposed project is located on a vacant lot in a developed industrial area at the end of a dead-end street, adjacent to a rail corridor and open space. The project has

Issue	Potentially Significant Impact	Less Than Significant with Mitigation Incorporated	Less Than Significant Impact	No Impact
-------	--------------------------------	--	------------------------------	-----------

the potential to support the movement of migratory species because of proximity to MHPA open space which provides connectivity to Los Penasquitos Canyon and Carroll Canyon Creek, but would not interfere with such movement or adjacent wildlife corridors.

- e) Conflict with any local policies or ordinances protecting biological resources, such as a tree preservation policy or ordinance?

The proposed project would not conflict with any local policies or ordinances protecting biological resources, such as a tree preservation policy or ordinance. The project and associated mitigation has been developed to be consistent with the City’s MSCP Subarea Plan and MHPA Land Use Adjacency Guidelines as further described above in IV.a.

- f) Conflict with the provisions of an adopted Habitat Conservation Plan, Natural Community Conservation Plan, or other approved local, regional, or state habitat conservation plan?

The proposed project would not conflict with the provisions of any local plans protecting biological resources. The project and associated mitigation has been developed to be consistent with the City’s MSCP Subarea Plan and MHPA Land Use Adjacency Guidelines therefore would not conflict with an adopted Habitat Conservation Plan or other approved local, regional or state habitat conservation plan.

V. CULTURAL RESOURCES – Would the project:

- a) Cause a substantial adverse change in the significance of an historical resource as defined in §15064.5?

The purpose and intent of the Historical Resources Regulations of the Land Development Code (Chapter 14, Division 3, and Article 2) is to protect, preserve and, where damaged, restore the historical resources of San Diego. The regulations apply to all proposed development within the City of San Diego when historical resources are present on the premises. CEQA requires that before approving discretionary projects, the Lead Agency must identify and examine the significant adverse environmental effects, which may result from that project. A project may have a significant effect on the environment (Sections 15064.5(b) and 21084.1). A substantial adverse change is defined as demolition, destruction, relocation, or alteration activities, which would

Issue	Potentially Significant Impact	Less Than Significant with Mitigation Incorporated	Less Than Significant Impact	No Impact
-------	--------------------------------	--	------------------------------	-----------

impair historical significance (Sections 15064.5(b)(1)). Any historical resource listed in, or eligible to be listed in the California Register of Historical Resources, including archaeological resources, is considered to be historically or culturally significant. Because the potential does exist that cultural material could be found or that traces of recorded sites might be uncovered, an archaeological and Native American monitor would be present on site during the trenching. The implementation of these mitigation requirements would reduce potential impacts to historical resources to below a level of significance and would not result in a substantial adverse change to the significance of an historical resource.

There are no “built-environment” resources within the project site. However, the project site contains an important archaeological site and tribal cultural resource which was designated by the City’s Historical Resources Board on July 23, 2009 as HRB #924, Village of Ystagua Area #1. The project proposes to re-contour the existing unauthorized fill placement on the project site to provide adequate contours to accommodate the concrete pad, trailer and drainage. Minor ground-disturbing activity would occur in association with utilities and landscaping, including work associated with wetland restoration of the previously impacted areas on the property. A research design and data recovery program were developed in consultation with Mr. Clint Linton, Native American Kumeyaay representative from the Iipay Nation of Santa Ysabel. Implementation of the ADRP and monitoring would serve to mitigate any project-related impacts to historical resources to below a level of significance and would not result in a substantial adverse change to the significance of an historical resource.

- b) Cause a substantial adverse change in the significance of an archaeological resource pursuant to §15064.5?

The project site contains an important archaeological site and tribal cultural resource, the Kumeyaay Village of Ystagua which still contains the physical remains of many native people who were buried there over the course of many millennia. Further evaluations conducted on the subject property identified stratified deposits, artifacts associated with Native American use of the site/area before Spanish contact and historically, and the presence of human remains, which resulted in the determination by the City of San Diego that site, P-37-004609 (CA-SDI-4609) is an important archaeological site, eligible for local designation on the City’s Historical Resources Register (HRR). As such, the was designated to by the Historical Resources Board and placed on the HRR as HRB# 924- Village of Ystagua, Area #1 on July 23, 2009.

The project proposes to re-contour the existing unauthorized fill placement on the project site to provide adequate contours to accommodate the concrete pad, trailer and drainage. Minor ground-disturbing activity would occur in association with utilities and landscaping, including work associated with wetland restoration of the previously impacted areas on the property. A research design and data recovery program were developed in consultation with Mr. Clint Linton, Native American Kumeyaay representative from the Iipay Nation of Santa Ysabel. Implementation of the ADRP and

Issue	Potentially Significant Impact	Less Than Significant with Mitigation Incorporated	Less Than Significant Impact	No Impact
-------	--------------------------------	--	------------------------------	-----------

monitoring would serve to mitigate any project-related impacts to historical resources to below a level of significance and would not result in a substantial adverse change to the significance of an historical resource.

Furthermore, this project was subject to tribal consultation in accordance with Assembly Bill 52 (AB52) and as such resulted in a recommendation for Native American Kumeeyaay monitoring due to the high potential for human remains to be encountered anywhere in the project vicinity. As such, the project is required to implement the mitigation measures outlined in Section V of the MND under Historical Resources (Archaeology) which will reduce potential impacts to below a level of significance.

- | | | | | |
|---|--------------------------|--------------------------|--------------------------|-------------------------------------|
| c) Directly or indirectly destroy a unique paleontological resource or site or unique geologic feature? | <input type="checkbox"/> | <input type="checkbox"/> | <input type="checkbox"/> | <input checked="" type="checkbox"/> |
|---|--------------------------|--------------------------|--------------------------|-------------------------------------|

According to information provided in the Cultural Resources Report regarding the physical setting of the site, the vacant parcel is underlain by Quaternary Alluvium (Qal) and slope wash (Qsw), which consists of silts, sands and cobbles that have been derived from nearby geologic formation and deposited either by alluvial or colluvial processes (floodplain deposition or slope wash). This geological deposit/rock unit is given a low sensitivity rating with respect to the potential for impacting fossil resources (City of San Diego Significance Thresholds, 2016), and therefore no impact would occur to paleontological or unique geologic resources.

- | | | | | |
|---|--------------------------|-------------------------------------|--------------------------|--------------------------|
| d) Disturb any human remains, including those interred outside of dedicated cemeteries? | <input type="checkbox"/> | <input checked="" type="checkbox"/> | <input type="checkbox"/> | <input type="checkbox"/> |
|---|--------------------------|-------------------------------------|--------------------------|--------------------------|

Please refer to section V.a. Archaeological and Native American monitoring will be required during all construction related activities. If human remains are encountered, all provisions of the Mitigation Monitoring and Reporting Program (MMRP), the California Public Resources Code, and the California Health and Safety Code will be implemented to ensure the appropriate treatment of any burials or associated grave goods.

VI. GEOLOGY AND SOILS – Would the project:

- a) Expose people or structures to potential substantial adverse effects, including the risk of loss, injury, or death involving:

Issue	Potentially Significant Impact	Less Than Significant with Mitigation Incorporated	Less Than Significant Impact	No Impact
-------	--------------------------------	--	------------------------------	-----------

i) Rupture of a known earthquake fault, as delineated on the most recent Alquist-Priolo Earthquake Fault Zoning Map issued by the State Geologist for the area or based on other substantial evidence of a known fault? Refer to Division of Mines and Geology Special Publication 42.

The project site is not located within an Alquist-Priolo Fault Zone; however, the City of San Diego Seismic Safety Maps indicate the presence of three Geologic Hazard Categories across the project site. Category 21: landslide confirmed, highly suspect; Category 25: Slide Prone, Ardatth Shale Formation, neutral or favorable geologic structure; Category 31: Liquefaction, high potential, shallow groundwater, major drainage, hydraulic fills. The proposed project does not include any permanent structures for human occupancy and would not require any major engineering or construction activities other than the removal of non-native vegetation, shrubs and exotic trees, installation of a new drainage system for the site, and recontouring of unauthorized fill to facilitate a concrete pad for placement of an office trailer. Therefore, risk from rupture of a known earthquake fault in this category would be less than significant.

ii) Strong seismic ground shaking?

See VI.a.i. The proposed project would utilize proper engineering design and construction practices to ensure that the potential for impacts from ground shaking would remain less than significant.

iii) Seismic-related ground failure, including liquefaction?

According to the City of San Diego Seismic Safety Maps, the proposed project is underlain by Salinas Clay Loam which consists of deep, well drained soils that formed in alluvium weathered from sandstone and shale. Salinas soils are on alluvial plains, fans, and terraces and have slopes of 0 to 9 percent, and Altamont Clay (30-50% slopes) which consist of deep, well drained soils that formed in material weathered from fine-grained sandstone and shale. These soils are on gently sloping to very steep uplands. The project does not include any permanent structures for human occupancy and only will require engineering or construction

Issue	Potentially Significant Impact	Less Than Significant with Mitigation Incorporated	Less Than Significant Impact	No Impact
-------	--------------------------------	--	------------------------------	-----------

activities to facilitate removal and re-contouring of fill soil with minimal trenching for utility connections and drainage system. The potential for impacts from liquefaction after required grading activities would be less than significant.

- iv) Landslides?

The proposed project is located on Quaternary Alluvium and Slope Wash, which are steep slopes of specific soils that are easily disturbed and prone to erosion. According to the Landslide Hazards map from the California Department of Conservation Division of Mines and Geology, these geologic formations are susceptible to liquefaction, settlement, dynamic consolidation, slope instability, and poor foundation characteristics. However, the proposed project involves the removal and re-contouring of unauthorized fill soils placed on the site to facilitate construction of a concrete pad for an office trailer, installation of a drainage system and utility connection, and implementation of a habitat restoration plan. The majority of the property would be conserved in open space with no future development potential. These activities would not expose people or structures to the risk of loss, injury, or death involving landslides, and as such the potential for impacts from landslides would be less than significant.

- b) Result in substantial soil erosion or the loss of topsoil?

Please refer to response to A.iii and iv. The proposed project involves the removal and re-contouring of unauthorized fill soils placed on the site to facilitate construction of a concrete pad for an office trailer, installation of a drainage system and utility connection, and implementation of a habitat restoration plan. The majority of the property would be conserved in open space with no future development potential. Restoration of the site and implementation of applicable Best Management Practices would preclude the potential for soil erosion or loss of topsoil

- c) Be located on a geologic unit or soil that is unstable, or that would become unstable as a result of the project, and potentially result in on- or off-site landslide, lateral spreading, subsidence, liquefaction or collapse?

City of San Diego Seismic Safety Maps indicate the presence of three Geologic Hazard Categories across the project site. Category 21: landslide confirmed, highly suspect; Category 25: Slide Prone, Ardath Shale Formation, neutral or favorable geologic structure; Category 31: Liquefaction, high potential, shallow groundwater, major drainage, hydraulic fills. The proposed project does not include any permanent structures for human occupancy and would not require any major engineering or construction activities other

Issue	Potentially Significant Impact	Less Than Significant with Mitigation Incorporated	Less Than Significant Impact	No Impact
-------	--------------------------------	--	------------------------------	-----------

than for the removal of non-native vegetation, shrubs and exotic trees, installation of a new drainage system for the site, and removal/recontouring of unauthorized fill to facilitate a concrete pad for placement of an office trailer. The project is located in an area with moderate risk for the potential to result in on- or off-site landslide, lateral spreading, subsidence, liquefaction or collapse. Implementation of standard engineering requirements in accordance with the City's grading ordinance would preclude the potential for impacts in this category based on regional geologic hazards; therefore, impacts would be less than significant.

- d) Be located on expansive soil, as defined in Table 18-1-B of the Uniform Building Code (1994), creating substantial risks to life or property?
- | | | | | |
|--|--------------------------|--------------------------|-------------------------------------|--------------------------|
| | <input type="checkbox"/> | <input type="checkbox"/> | <input checked="" type="checkbox"/> | <input type="checkbox"/> |
|--|--------------------------|--------------------------|-------------------------------------|--------------------------|

The proposed project does not include any permanent structures for human occupancy and would not require any major engineering or construction activities other than for the removal of non-native vegetation, shrubs and exotic trees, installation of a new drainage system for the site, and removal/recontouring of unauthorized fill to facilitate a concrete pad for placement of an office trailer; Implementation of standard engineering requirements in accordance with the City's grading ordinance would preclude the potential for impacts in this category therefore, the potential for impacts from expansive soil would be less than significant.

- e) Have soils incapable of adequately supporting the use of septic tanks or alternative waste water disposal systems where sewers are not available for the disposal of waste water?
- | | | | | |
|--|--------------------------|--------------------------|--------------------------|-------------------------------------|
| | <input type="checkbox"/> | <input type="checkbox"/> | <input type="checkbox"/> | <input checked="" type="checkbox"/> |
|--|--------------------------|--------------------------|--------------------------|-------------------------------------|

The project would not utilize septic tanks or alternative wastewater systems. Therefore, no impact would occur.

VII. GREENHOUSE GAS EMISSIONS - Would the project:

- a) Generate greenhouse gas emissions, either directly or indirectly, that may have a significant impact on the environment?
- | | | | | |
|--|--------------------------|--------------------------|-------------------------------------|--------------------------|
| | <input type="checkbox"/> | <input type="checkbox"/> | <input checked="" type="checkbox"/> | <input type="checkbox"/> |
|--|--------------------------|--------------------------|-------------------------------------|--------------------------|

The City of San Diego, as of July 2016, is utilizing the Climate Action Plan Consistency Checklist (Checklist) to provide a streamlined review process for proposed new development projects that are subject to discretionary review and trigger environmental review pursuant to CEQA. The first step in determining CAP consistency is to assess a project's consistency with the land use assumptions used in the CAP. Specifically, in Step

Issue	Potentially Significant Impact	Less Than Significant with Mitigation Incorporated	Less Than Significant Impact	No Impact
-------	--------------------------------	--	------------------------------	-----------

1, the proposed project must be determined to be consistent with the existing General Plan and Community Plan land use and zoning designations.

The CAP Consistency Checklist is part of the CAP and contains measures that are required to be implemented on a project-by-project basis to ensure that the specified emissions targets identified in the CAP are achieved. Implementation of these measures would ensure that new development is consistent with the CAP's assumptions for relevant CAP strategies toward achieving the identified GHG reduction targets. Projects that are consistent with the CAP as determined through the use of the CAP Consistency Checklist may rely on the CAP for the cumulative impact analysis of GHG emissions. Cumulative GHG impacts would be significant for any project that is not consistent with the CAP.

A project-specific CAP Consistency Checklist has been completed for the project, and its requirements would become conditions of project approval. As detailed in the project-specific CAP Consistency Checklist Step 1, the project is consistent with the allowed uses per the General Plan and Community Plan land use designations for the project site. Thus, the review would proceed to Step 2 of the Checklist to evaluate a project's consistency with the applicable strategies and actions of the CAP. However, Step 2 only applies to development projects that involve permits that would require a certificate of occupancy. Since this project does not require a certificate of occupancy, the review is complete and the project is determined to be consistent with the CAP. The project would therefore, not cause any significant increase in GHG emissions, and no mitigation is required. Impacts would be less than significant.

Based on the project's consistency with the City's CAP Checklist, the project's contribution of GHGs to cumulative statewide emissions would be less than cumulatively considerable. Therefore, the project's direct and cumulative GHG emissions would have a less than significant impact on the environment.

- b) Conflict with an applicable plan, policy, or regulation adopted for the purpose of reducing the emissions of greenhouse gases?

<input type="checkbox"/>	<input type="checkbox"/>	<input checked="" type="checkbox"/>	<input type="checkbox"/>
--------------------------	--------------------------	-------------------------------------	--------------------------

Please also see VII.a. It is anticipated that the proposed projects would not conflict with any applicable plans, policies, or regulations related to greenhouse gases. Impacts would be less than significant.

VIII. HAZARDS AND HAZARDOUS MATERIALS – Would the project:

- a) Create a significant hazard to the public or the environment through routine transport, use, or disposal of hazardous materials?

<input type="checkbox"/>	<input type="checkbox"/>	<input checked="" type="checkbox"/>	<input type="checkbox"/>
--------------------------	--------------------------	-------------------------------------	--------------------------

Construction of the proposed project may require the use of hazardous materials (fuels, lubricants, solvents, etc.), which would require proper storage, handling, use and disposal;

Issue	Potentially Significant Impact	Less Than Significant with Mitigation Incorporated	Less Than Significant Impact	No Impact
-------	--------------------------------	--	------------------------------	-----------

however, the project would not routinely transport, use or dispose of hazardous materials. In addition, construction standards shall be implemented for any subsurface discoveries, to meet local, state, and federal standards. Therefore, the project would not create a significant hazard to the public or environment.

- b) Create a significant hazard to the public or the environment through reasonably foreseeable upset and accident conditions involving the release of hazardous materials into the environment?

As noted in previous response VIII (a), no health risks related to the storage, transport, use, or disposal of hazardous materials would result from the implementation of the project. The project would not be associated with such impacts. Therefore, impacts would be less than significant.

- c) Emit hazardous emissions or handle hazardous or acutely hazardous materials, substances, or waste within one-quarter mile of an existing or proposed school?

There are no schools within a quarter mile of the project boundary. Impacts would not occur.

- d) Be located on a site which is included on a list of hazardous materials sites compiled pursuant to Government Code Section 65962.5 and, as a result, would it create a significant hazard to the public or the environment?

The project site is not included on a list of hazardous materials sites compiled pursuant to Government Code Section 65962.5. No impact would occur.

- e) For a project located within an airport land use plan or, where such a plan has not been adopted, within two miles of a public airport or public use airport, would the

Issue	Potentially Significant Impact	Less Than Significant with Mitigation Incorporated	Less Than Significant Impact	No Impact
-------	--------------------------------	--	------------------------------	-----------

project result in a safety hazard for people residing or working in the project area?

The proposed project is located within the boundaries of an airport land use plan for MCAS Miramar (Accident Potential Zone, Airport Influence Area, FAA Part 77) which required a consistency review of the project by the San Diego Regional Airport Authority Airport Land Use Commission. The ALUC's determination was made on March 5, 2009 that the 10325 Roselle Street project is consistent with the MCAS Miramar ALUCP was made consistent with the ALUC Policies and the State Aeronautics Act provisions (Cal. Pub. Util. Code §21670-21679 .5). There would be no impact.

- f) For a project within the vicinity of a private airstrip, would the project result in a safety hazard for people residing or working in the project area?

The proposed project is not within the vicinity of a private airstrip.

- g) Impair implementation of or physically interfere with an adopted emergency response plan or emergency evacuation plan?

The proposed project would only temporarily affect traffic circulation within the project area. However, a traffic control plan would be implemented during construction activities which would allow emergency plans to be employed and uninterrupted. Impacts would be less than significant.

- h) Expose people or structures to a significant risk of loss, injury or death involving wildland fires, including where wildlands are adjacent to urbanized areas or where residences are intermixed with wildlands?

There are no residential uses on, or proposed for the project site. Although the industrial zoned project site is mapped within Very High Fire Hazard Severity Zone with 100- and 300-foot buffer requirements, the proposed project would not introduce any new features that would increase the risk of wildland fires. Furthermore, the project involves the removal of non-native, invasive vegetation and implementation of a wetland habitat restoration plan with a 100-foot buffer to the adjacent creek. Removal of non-native species, in conjunction with native habitat restoration and long-term maintenance/monitoring of the

Issue	Potentially Significant Impact	Less Than Significant with Mitigation Incorporated	Less Than Significant Impact	No Impact
-------	--------------------------------	--	------------------------------	-----------

site will preclude the potential for the spread of wildland fires. As such, impacts would be less than significant.

IX. HYDROLOGY AND WATER QUALITY - Would the project:

- a) Violate any water quality standards or waste discharge requirements?

Potential impacts to existing water quality associated with the proposed project would include minimal short-term construction-related activities and no long term operational storm water discharges from proposed use of the site as a vehicle/equipment maintenance area. In addition to removing and recontouring unauthorized fill placed on the site, the project includes construction of a new drainage system and connections to existing utilities. The project would also implement structural and non-structural Best Management Practices in accordance with the City's Storm Water Standards which would prevent or effectively minimize short-term water quality impacts. Therefore, the proposed project would not violate any existing water quality standards or discharge requirements applicable to the site.

- b) Substantially deplete groundwater supplies or interfere substantially with groundwater recharge such that there would be a net deficit in aquifer volume or a lowering of the local groundwater table level (e.g., the production rate of pre-existing nearby wells would drop to a level which would not support existing land uses or planned uses for which permits have been granted)?

The proposed project does not propose the use of groundwater. Furthermore, the project would not introduce significant new impervious surfaces that could interfere with groundwater recharge. Therefore, the proposed project would not substantially deplete groundwater supplies or interfere substantially with groundwater recharge.

- c) Substantially alter the existing drainage pattern of the site or area, including through the alteration of the course of a stream or river, in a manner, which would result in substantial erosion or siltation on- or off-site?

Issue	Potentially Significant Impact	Less Than Significant with Mitigation Incorporated	Less Than Significant Impact	No Impact
-------	--------------------------------	--	------------------------------	-----------

According to the Drainage Study prepared for the project (Stevens-Cresto Engineering, 2015), all of the storm water runoff generated by the project is tributary to Carroll Canyon Creek. The creek passes through the eastern half of the property, running south to north. Based on floodway data for the creek, found in Table 8 - Floodway Data from the FEMA Flood Insurance Study for San Diego County, CA and Incorporated Areas, dated June 19, 1997, the flow rate in the creek, adjacent to the project, during a 100-year storm event, is approximately 6,700 cfs.

The majority of the project property will remain unchanged in the proposed condition and, as a result, those portions will not be included in this study. The hydrological study analyzed the area of interest as a single Basin "A" subdivided into Basins "AN" and "AS". Though both sub-basins drain into Carroll Canyon Creek within the project boundary, runoff from Basin "AS" enters the creek south of Basin "AN" and runoff from Basin "AN" enters the creek near the northern project boundary. Basin "A" is approximately 3.26 acres and is divided into two sub-basins; "AN-1" and "AS-1". Runoff generated by Basin "AN-1" is conveyed to the north, via overland flow, and enters Carroll Canyon Creek near the northern project boundary. Basin "AS-1" is mostly hillside. Runoff from the basin is conveyed to the north, via overland flow, and enters Carroll Canyon Creek upstream of Basin "AN-1", within the project boundary. A total of approximately 5.8 cfs of runoff is generated by Basin "A" during a 100-year design storm.

The Drainage Study describes the proposed hydrology for the project as follows:

Proposed Basin "A" is approximately 3.26 acres and is divided into four sub-basins; "AN-1", "AN-2", "AN-3", and "AS-1". Basin "AN-1" contains the majority of the proposed stabilized pad. Storm water runoff generated by the pad is conveyed to the north, via overland flow, to a swale along the northern edge of the pad. The swale directs runoff to a proposed catch basin in the northern corner of the pad. From there, a 12" storm drain conveys runoff to the northwest, to an existing 60" RCP storm drain that discharges into Carroll Canyon Creek along the northern project boundary. Basin "AN-3" contains a small portion of the stabilized pad on the south side of the proposed landscaped berm along the project frontage. Because of the berm, the approximately 0.05 cfs of runoff generated by the basin during a 100-year design storm will now drain into Roselle Street instead of draining directly into Carroll Canyon Creek. Basin "AS-1" contains only a small portion of the stabilized pad and will remain largely unchanged in the proposed condition. A total of approximately 5.7 cfs of runoff will be generated by proposed Basin "A" during a 100-year design storm.

In order to prevent runoff and sediments from entering Carroll Canyon Creek, as described above a proposed catch basin and storm drain pipe has been designed that will collect pad runoff and convey it to the northwest where it will discharge into an existing 60" RCP storm drain. The 60" RCP will discharge into Carroll Canyon Creek along the northern project boundary. Creation of the stabilized pad will flatten out a large portion of the project property, allowing storm water runoff to be conveyed as overland sheet flow for a longer period of time. This will increase the peak time of concentration for the basin and offset the small increase in runoff coefficient that will result from having a compacted pad. In the proposed condition, runoff from Basin "A" will decrease by 0.1 cfs; which is a negligible change. Therefore, the proposed project would not substantially alter any existing drainage

Issue	Potentially Significant Impact	Less Than Significant with Mitigation Incorporated	Less Than Significant Impact	No Impact
-------	--------------------------------	--	------------------------------	-----------

patterns or area, including through the alteration of the course of a stream or river, in a manner, which would result in substantial erosion or siltation on- or off-site. Compliance with the City's Storm Water Standards is required for all projects and assured through implementation of structural and non-structural BMP's. As such, impacts are less than significant.

- d) Substantially alter the existing drainage pattern of the site or area, including through the alteration of the course of a stream or river, or substantially increase the rate or amount of surface runoff in a manner, which would result in flooding on- or off-site?

Please see IX.c. Since the project would not substantially alter the existing drainage patterns and would not introduce substantial impermeable surfaces, the rate of surface runoff would not be increased and as such would not increase the rate or amount of surface runoff resulting in flooding on or offsite. As such, impacts are less than significant.

- e) Create or contribute runoff water, which would exceed the capacity of existing or planned stormwater drainage systems or provide substantial additional sources of polluted runoff?

Please see IX.c and d. Conformance to BMP's outlined in the Drainage Study and included on project plans, in conjunction with compliance with the City Storm Water Standards would prevent or effectively minimize short-term construction impacts. Therefore, the project would not contribute runoff water that would exceed the capacity of existing storm water systems.

- f) Otherwise substantially degrade water quality?

Please see IX.c and d. Conformance to BMPs outlined in the in the Drainage Study and included on project plans, in conjunction with compliance with the City's Storm Water Standards would prevent or effectively minimize impacts and would preclude impacts to water quality.

- g) Place housing within a 100-year flood hazard area as mapped on a federal Flood Hazard Boundary or Flood

Issue	Potentially Significant Impact	Less Than Significant with Mitigation Incorporated	Less Than Significant Impact	No Impact
-------	--------------------------------	--	------------------------------	-----------

Insurance Rate Map or other flood hazard delineation map?

The project site is located on the Federal Emergency Management Agency’s (FEMA) Flood Insurance Rate Map (FIRM), Community Panel No. 06073C1339G, dated May 16, 2012, for the City of San Diego, California, updated and revised pursuant to Letter of Map Revision (LOMR) Determination Document effective July 24, 2017 and revised the effective National Flood Insurance Program (NFIP) map panel (Panel 1339 of 2375) associated with the project site. Because the initial grading violation placed unauthorized fill soil in an area with a significant archaeological and tribal cultural resource site, in the original FEMA Regulatory Floodway, a map revision was required by the City to allow the fill to remain in place, rather than remove and further disturb the archaeological site. The LOMR was approved by FEMA in 2017 which revised the location of the Regulatory Floodway on the project site, allowing for site restoration and project implementation.

The proposed project does not propose construction of any new permanent housing within a 100-year Flood Hazard Boundary; however, placement of a mobile trailer on a new concrete stabilized pad will be installed in an area of the project site identified by the City and FEMA as within Zone X. FIRM Community Panel No. 06073C1339G further characterizes this area of the site as follows: .0.2% Annual Chance of Flood Hazard. Areas of 1% annual chance of flood with average depth less than one foot or with drainage areas of less than one square mile. The remaining areas of the project site are within the following Special Flood Hazard Areas: without Base Flood Elevations (BFE) - Zone A, V, A99 and Regulatory Floodway - Zones AE, AO, AH, VE, and AR. These areas would only be subject to habitat restoration and open space conservation where no housing could be developed. Compliance with engineering requirements of the grading permit would assure that the proposed project would n

h) Place within a 100-year flood hazard area, structures that would impede or redirect flood flows?

See IV.g. above. The project site is located on the Federal Emergency Management Agency’s (FEMA) Flood Insurance Rate Map (FIRM), Community Panel No. 06073C1339G, dated May 16, 2012, for the City of San Diego, California, updated and revised pursuant to Letter of Map Revision (LOMR) Determination Document effective July 24, 2017 and revised the effective National Flood Insurance Program (NFIP) map panel (Panel 1339 of 2375) associated with the project site.

Implementation of the proposed project, which includes wetlands habitat restoration, recontouring of unauthorized fill materials, a new stabilized concrete pad for mobile trailer and associated utility and drainage systems, would not impeded or redirect flood flows, and therefore with implementation of engineering requirements outlined in the Drainage Study and incorporated into the conceptual grading plan, impacts would be less than significant.

Issue	Potentially Significant Impact	Less Than Significant with Mitigation Incorporated	Less Than Significant Impact	No Impact
-------	--------------------------------	--	------------------------------	-----------

- i) Expose people or structures to a significant risk of loss, injury or death involving flooding, including flooding as a result of the failure of a levee or dam?

See IX.g and h. above. The proposed project would not include any new features within the FEMA Regulatory Floodway or associated with the proposed development footprint that would increase the risk associated with flooding beyond those of the proposed recontoured site conditions.

- j) Inundation by seiche, tsunami, or mudflow?

The proposed project would not include any new features that would increase the risk associated with seiche, tsunami, or mudflow beyond those of the proposed recontoured site conditions.

X. LAND USE AND PLANNING – Would the project:

- a) Physically divide an established community?

Implementation of the proposed project would not introduce any features that could physically divide an established community.

- b) Conflict with any applicable land use plan, policy, or regulation of an agency with jurisdiction over the project (including but not limited to the general plan, specific plan, local coastal program, or zoning ordinance) adopted for the purpose of avoiding or mitigating an environmental effect?

The proposed project is located within the coastal zone of Sorrento Valley which allows industrial uses as designated in the Torrey Pines Community Plan. The project site is presently vacant, with disturbed areas, upland, riparian, and wetland habitat, and MHPA open space. The project has been designed to be consistent with all applicable land use plans, policies, or regulations of an agency with jurisdiction over the project and would not conflict with any applicable land use plans. Although the project is in the Coastal Zone, permit issuance falls under the City of San Diego’s land use authority, but is appealable to the California Coastal Commission. The project will impact 1.32 acres of habitat and prior impacts within the previous FEMA Regulatory Floodway requiring issuance of a Site Development Permit in accordance with the City’s Environmentally Sensitive Lands

Issue	Potentially Significant Impact	Less Than Significant with Mitigation Incorporated	Less Than Significant Impact	No Impact
-------	--------------------------------	--	------------------------------	-----------

Regulation of the LDC. Impacts to biological resources applicable to the Coastal Overlay Zone are addressed in the Biology Report and determined to not meet the ESHA definition as further described below.

Because this site is in the Coastal Overlay Zone, the California Coastal Act and Coastal Commission regulations apply, specifically those applying to ESHA. The California Coastal Act, Section 30107.5, defines an Environmentally Sensitive Area as “any area in which plant or animal life or their habitats are either rare or especially valuable because of their special nature or role in an ecosystem and which could be easily disturbed or degraded by human activities and developments”. In order to determine if an area constitutes an ESHA, the Coastal Commission determines if the following criteria are met:

- 1) There are rare species or habitat in the subject area;
- 2) There are especially valuable species or habitats in the area, which is determined based on:
 - a. whether any species or habitat that is present has a special nature, OR
 - b. whether any species or habitat that is present has a special role in the ecosystem

As coastal sage scrub is a Tier II habitat, it is considered an uncommon upland rather than rare. Because the coastal sage scrub on-site is disturbed and contains patches of highly invasive species such as pampas grass, stinkwort (*Dittrichia graveolens*) and Russian-thistle, it is unlikely to support rare or especially valuable species. No special-status species were observed in or adjacent to the impact area during the most recent site visit and Dudek only reported observing one juvenile orange-throated whiptail (*Aspidoscelis hyperythra*) between riparian vegetation and the steep hillside, on the opposite side of the site from the impact area. Other special-status species that were determined to have a moderate or high potential to occur would only use the riparian habitat or adjacent hillside, which is not being impacted. Even if orange-throated whiptail is present in the disturbed coastal sage scrub that would be impacted, it is relatively widespread and should not be considered rare or especially valuable, regardless of its status as a State Species of Special Concern. Neither orange-throated whiptail nor the disturbed coastal sage scrub area is likely to have a special role in the ecosystem. Due to the above reasons, the impacted area on-site should not be considered an ESHA.

- c) Conflict with any applicable habitat conservation plan or natural community conservation plan?

The proposed project would not conflict with the provisions of any local plans protecting biological resources. The project and associated mitigation has been developed to be consistent with the City’s MSCP Subarea Plan and MHPA Land Use Adjacency Guidelines therefore would not conflict with an adopted Habitat Conservation Plan or other approved local, regional or state habitat conservation plan or natural community conservation plan.

XI. MINERAL RESOURCES – Would the project?

Issue	Potentially Significant Impact	Less Than Significant with Mitigation Incorporated	Less Than Significant Impact	No Impact
-------	--------------------------------	--	------------------------------	-----------

- a) Result in the loss of availability of a known mineral resource that would be of value to the region and the residents of the state?

The area surrounding the proposed project is not being used for the recovery of mineral resources. Similarly, the area surrounding the proposed project site is not designated for the recovery of mineral resources on the City of San Diego General Plan Land Use Map. Therefore, the proposed project would not result in the loss of availability of a known mineral resource.

- b) Result in the loss of availability of a locally important mineral resource recovery site delineated on a local general plan, specific plan or other land use plan?

Please see XI.a.

XII. NOISE – Would the project result in:

- a) Exposure of persons to, or generation of, noise levels in excess of standards established in the local general plan or noise ordinance, or applicable standards of other agencies?

The proposed project would only generate noise during construction activities, which would be temporary and transitory in nature. Therefore, people would not be exposed to noise levels in excess of any noise regulations.

- b) Exposure of persons to, or generation of, excessive ground borne vibration or ground borne noise levels?

Please see XII.a.

- c) A substantial permanent increase in ambient noise levels in the project vicinity above levels existing without the project?

Please see XII.a.

Issue	Potentially Significant Impact	Less Than Significant with Mitigation Incorporated	Less Than Significant Impact	No Impact
-------	--------------------------------	--	------------------------------	-----------

- d) A substantial temporary or periodic increase in ambient noise levels in the project vicinity above existing without the project?
- | | | | |
|--------------------------|--------------------------|-------------------------------------|--------------------------|
| <input type="checkbox"/> | <input type="checkbox"/> | <input checked="" type="checkbox"/> | <input type="checkbox"/> |
|--------------------------|--------------------------|-------------------------------------|--------------------------|

Construction of the proposed project would result in a temporary increase in the ambient noise levels in the project vicinity. However, based upon the transitory nature of the project and surrounding noise levels in the area resulting from the adjacent rail and highway traffic, the increase in ambient noise would be less than significant.

- e) For a project located within an airport land use plan, or, where such a plan has not been adopted, within two miles of a public airport or public use airport would the project expose people residing or working in the area to excessive noise levels?
- | | | | |
|--------------------------|--------------------------|--------------------------|-------------------------------------|
| <input type="checkbox"/> | <input type="checkbox"/> | <input type="checkbox"/> | <input checked="" type="checkbox"/> |
|--------------------------|--------------------------|--------------------------|-------------------------------------|

The proposed project area is within the airport land use plan for MCAS Miramar, but not within two miles of a public airport. The project site is within an area designated for industrial land uses where office buildings, light manufacturing and other light industrial uses are allowed. No residential uses or housing can be found in the area. Overflight noise from MCAS Miramar is an existing condition where no permanent sensitive receptors occur. As such, no impact would result.

- f) For a project within the vicinity of a private airstrip, would the project expose people residing or working in the project area to excessive noise levels?
- | | | | |
|--------------------------|--------------------------|--------------------------|-------------------------------------|
| <input type="checkbox"/> | <input type="checkbox"/> | <input type="checkbox"/> | <input checked="" type="checkbox"/> |
|--------------------------|--------------------------|--------------------------|-------------------------------------|

The proposed project area is not within the vicinity of a private airstrip.

XIII. POPULATION AND HOUSING – Would the project:

- a) Induce substantial population growth in an area, either directly (for example, by proposing new homes and businesses) or indirectly (for example, through extension of roads or other infrastructure)?
- | | | | |
|--------------------------|--------------------------|--------------------------|-------------------------------------|
| <input type="checkbox"/> | <input type="checkbox"/> | <input type="checkbox"/> | <input checked="" type="checkbox"/> |
|--------------------------|--------------------------|--------------------------|-------------------------------------|

Issue	Potentially Significant Impact	Less Than Significant with Mitigation Incorporated	Less Than Significant Impact	No Impact
-------	--------------------------------	--	------------------------------	-----------

The project does not propose the construction of new housing, businesses, roadways or infrastructure that could induce growth.

- b) Displace substantial numbers of existing housing, necessitating the construction of replacement housing elsewhere?

No housing exists in the project area and therefore, the proposed project would not remove, displace, or otherwise affect existing housing in any way that would necessitate the construction of replacement housing.

- c) Displace substantial numbers of people, necessitating the construction of replacement housing elsewhere?

No housing exists in the project area and therefore, the proposed project would not remove, displace, or otherwise affect existing housing in any way that would necessitate the construction of replacement housing.

XIV. PUBLIC SERVICES

- a) Would the project result in substantial adverse physical impacts associated with the provisions of new or physically altered governmental facilities, need for new or physically altered governmental facilities, the construction of which could cause significant environmental impacts, in order to maintain acceptable service rations, response times or other performance objectives for any of the public services:

- i) Fire Protection

The proposed project would not result in population growth, and as such, would not trigger the need to construct or alter governmental facilities including fire protection facilities.

- ii) Police Protection

Issue	Potentially Significant Impact	Less Than Significant with Mitigation Incorporated	Less Than Significant Impact	No Impact
<u>The proposed project would not physically alter any police protection facilities in the area, or result in the need to construct or alter police protection facilities.</u>				
iii) Schools	<input type="checkbox"/>	<input type="checkbox"/>	<input type="checkbox"/>	<input checked="" type="checkbox"/>
<u>The proposed project would not trigger the need to physically alter any schools. Additionally, the proposed project would not include construction of future housing or induce growth that could increase demand for schools in the area.</u>				
v) Parks	<input type="checkbox"/>	<input type="checkbox"/>	<input type="checkbox"/>	<input checked="" type="checkbox"/>
<u>The proposed project would not physically alter any parks. Therefore, the proposed project would not create demand for new parks or other recreational facilities.</u>				
vi) Other public facilities	<input type="checkbox"/>	<input type="checkbox"/>	<input type="checkbox"/>	<input checked="" type="checkbox"/>
<u>The proposed project would not increase the demand for electricity, gas, or other public facilities, which already exist in the project area to serve the site.</u>				

XV. RECREATION –

- a) Would the project increase the use of existing neighborhood and regional parks or other recreational facilities such that substantial physical deterioration of the facility would occur or be accelerated?

There are no existing recreation areas in the project vicinity. Access to City-owned MSCP/MHPA open space, off-site to the south. Implementation of the proposed project would not preclude access to this area. The proposed project would not directly increase use of the open space or induce future growth that would result in additional trip to recreational facilities in the area. Therefore, the proposed project would not increase the use of existing recreational areas such that substantial physical deterioration of the facility would occur or be accelerated.

- b) Does the project include recreational facilities or require the construction or expansion of recreational facilities, which might have an adverse physical effect on the environment?

The proposed project does not include the construction of recreational facilities or require construction or expansion of recreational facilities.

Issue	Potentially Significant Impact	Less Than Significant with Mitigation Incorporated	Less Than Significant Impact	No Impact
-------	--------------------------------	--	------------------------------	-----------

XVI. TRANSPORTATION/TRAFFIC – Would the project?

- a) Conflict with an applicable plan, ordinance or policy establishing measures of effectiveness for the performance of the circulation system, taking into account all modes of transportation including mass transit and non-motorized travel and relevant components of the circulation system, including but not limited to intersections, streets, highways and freeways, pedestrian and bicycle paths, and mass transit?

Construction of the proposed project would temporarily affect traffic circulation within the project boundary in the area of construction. However, an approved Traffic Control Plan would be implemented during construction so that traffic circulation would not be substantially impacted. Therefore, the project would not result in an increase of traffic which is substantial in relation to existing traffic capacity.

- b) Conflict with an applicable congestion management program, including, but not limited to level of service standards and travel demand measures, or other standards established by the county congestion management agency for designated roads or highways?

Construction of the proposed project would temporarily affect traffic circulation within the project boundary. However, an approved Traffic Control Plan would be implemented during construction so that traffic would not exceed cumulative or individual level of service.

- c) Result in a change in air traffic patterns, including either an increase in traffic levels or a change in location that results in substantial safety risks?

Issue	Potentially Significant Impact	Less Than Significant with Mitigation Incorporated	Less Than Significant Impact	No Impact
-------	--------------------------------	--	------------------------------	-----------

The proposed project does not include any tall structures or new features that would exceed height requirements. Therefore, the projects would not affect air traffic patterns or introduce new safety hazards related to air traffic.

- d) Substantially increase hazards due to a design feature (e.g., sharp curves or dangerous intersections) or incompatible uses (e.g., farm equipment)?
- | | | | | |
|--|--------------------------|--------------------------|--------------------------|-------------------------------------|
| | <input type="checkbox"/> | <input type="checkbox"/> | <input type="checkbox"/> | <input checked="" type="checkbox"/> |
|--|--------------------------|--------------------------|--------------------------|-------------------------------------|

The proposed project would only introduce a concrete pad and new trailer to the vacant site, and implement a habitat restoration plan, designed to meet City standards and, therefore, would meet existing levels of safety.

- e) Result in inadequate emergency access?
- | | | | | |
|--|--------------------------|--------------------------|-------------------------------------|--------------------------|
| | <input type="checkbox"/> | <input type="checkbox"/> | <input checked="" type="checkbox"/> | <input type="checkbox"/> |
|--|--------------------------|--------------------------|-------------------------------------|--------------------------|

Construction of the proposed projects would temporarily affect traffic circulation within the project boundary. However, an approved Traffic Control Plan would be implemented during construction so that there would be adequate emergency access to and from the project site.

- f) Conflict with adopted policies, plans, or programs regarding public transit, bicycle, or pedestrian facilities, or otherwise decrease the performance or safety of such facilities?
- | | | | | |
|--|--------------------------|--------------------------|--------------------------|-------------------------------------|
| | <input type="checkbox"/> | <input type="checkbox"/> | <input type="checkbox"/> | <input checked="" type="checkbox"/> |
|--|--------------------------|--------------------------|--------------------------|-------------------------------------|

The project is consistent with the community plan designation and underlying zone and would not result in any conflicts regarding policies, plans, or programs regarding public transit, bicycle or pedestrian facilities.

XVII. TRIBAL CULTURAL RESOURCES

- a) Would the project cause a substantial adverse change in the significance of a tribal cultural resource, defined in Public Resources Code section 21074 as either a site, feature, place, cultural landscape that is geographically defined in terms of the size and scope of the landscape, sacred place, or object with cultural value to a California Native American tribe, and that is:

Issue	Potentially Significant Impact	Less Than Significant with Mitigation Incorporated	Less Than Significant Impact	No Impact
-------	--------------------------------	--	------------------------------	-----------

- a) Listed or eligible for listing in the California Register of Historical Resources, or in a local register of historical resources as defined in Public Resources Code section 5020.1(k), or
- | | | | | |
|--|--------------------------|--------------------------|-------------------------------------|--------------------------|
| | <input type="checkbox"/> | <input type="checkbox"/> | <input checked="" type="checkbox"/> | <input type="checkbox"/> |
|--|--------------------------|--------------------------|-------------------------------------|--------------------------|

The proposed project would occur in an area where archaeological resources have been recorded. Site P-37-011571 represents a recorded archaeological site on Crown Point consisting mainly of intact and disturbed shell midden as well as cobble lithic artifacts, ecofacts and historic debris. The site has been evaluated in accordance with CEQA and the Public Resources Code, but does not meet the criteria for listing on the local, state or federal registers as defined in PRC Section 5020.1(k).

- b) A resource determined by the lead agency, in its discretion and supported by substantial evidence, to be significant pursuant to criteria set forth in subdivision (c) of Public Resources Code Section 5024.1. In applying the criteria set forth in subdivision (c) of Public Resource Code Section 5024.1, the lead agency shall consider the significance of the resource to a California Native American tribe.
- | | | | | |
|--|--------------------------|-------------------------------------|--------------------------|--------------------------|
| | <input type="checkbox"/> | <input checked="" type="checkbox"/> | <input type="checkbox"/> | <input type="checkbox"/> |
|--|--------------------------|-------------------------------------|--------------------------|--------------------------|

As stated above, the project has a potential to impact a tribal cultural resource as defined in Public Resources Code Section 21074 which has been determined to be significant by the City of San Diego pursuant to CEQA. As such, Tribal consultation was conducted in October 2017 with representatives from the Iipay Nation of Santa Ysabel and the Jamul Indian Village. Information was discussed with the consulting parties regarding significance of impacts to tribal cultural resources, and confidentiality of site information. Consultation included discussion of the project scope/plans, review of archaeological site capping proposal, onsite wetland enhancement and restoration, and other relevant project information associated with the mitigation program. Consultation concluded with all parties in agreement regarding the archaeological data recovery program and associated monitoring with a requirement and recommendation for Native American Kumeyaay participation during all phases of the mitigation program within the project area to ensure the appropriate treatment and protection of tribal cultural resources. A recommendation was also made to include a native plant palette that incorporates the following species traditionally utilized by the Native American tribes culturally affiliated with the project area, such as, but not limited to: deer grass (*Muhlenbergia rigens*), California buckwheat (*Eriogonum fasciculatum*), California sagebrush (*Artemisia californica*), laurel sumac (*Malosmd laurina*), coastal prickly pear (*Opuntia littoralis*), black sage (*Salvia mellifera*), western ragweed (*Ambrosia psilostachya*), mulefat (*Baccharis salicifolia*), western sycamore (*Platanus*

Issue	Potentially Significant Impact	Less Than Significant with Mitigation Incorporated	Less Than Significant Impact	No Impact
-------	--------------------------------	--	------------------------------	-----------

racemosa), Fremont's cottonwood (*Populus fremontii*), coast live oak (*Quercus agrifolia*), and willos (*Salix sp.*).

XVIII. UTILITIES AND SERVICE SYSTEMS – Would the project:

- a) Exceed wastewater treatment requirements of the applicable Regional Water Quality Control Board?

The proposed project would not exceed the requirements of the Regional Water Quality Control Board.

- b) Require or result in the construction of new water or wastewater treatment facilities or expansion of existing facilities, the construction of which could cause significant environmental effects?

Please see XVII a., the construction of new water or wastewater facilities would not be required for this project.

- c) Require or result in the construction of new storm water drainage facilities or expansion of existing facilities, the construction of which could cause significant environmental effects?

The project would not result in expanded impervious surface area beyond the small stabilized pad to support a mobile office trailer. The project will install a new drainage system on site to ensure that runoff is treated and directed to the City's storm drain system. The project would not result in substantial quantities of runoff which would require new or expanded facilities beyond those proposed to support the 1.32-acre project footprint which requires mitigation for impacts to onsite habitat and cultural resources.

- d) Have sufficient water supplies available to serve the project from existing entitlements and resources, or are new or expanded entitlements needed?

Water services are available to serve the project site, and as such the proposed project would not impact existing water supplies or require new or expanded facilities.

Issue	Potentially Significant Impact	Less Than Significant with Mitigation Incorporated	Less Than Significant Impact	No Impact
-------	--------------------------------	--	------------------------------	-----------

- e) Result in a determination by the wastewater treatment provided which serves or may serve the project that it has adequate capacity to serve the project's projected demand in addition to the provider's existing commitments?

Wastewater services are available to serve the project site, and as such the proposed project would not require new or expanded facilities and, therefore, would not impact an existing wastewater treatment provider.

- f) Be served by a landfill with sufficient permitted capacity to accommodate the project's solid waste disposal needs?

Implementation of the proposed project would generate waste associated with construction activities. This waste would be disposed of in conformance with all applicable local and state regulations pertaining to solid waste including permitting capacity of the landfill serving the project area. Materials able to be recycled would be done to meet local standards regulating such activity. Operation of the proposed project would generate minimal solid waste associated with the use of the site; however, the minimal generation of waste would not affect the permitted capacity of the landfill serving the project area.

- g) Comply with federal, state, and local statutes and regulation related to solid waste?

The proposed project would generate waste associated with construction activities. This waste would be disposed of in conformance with all applicable local and state regulations pertaining to solid waste including permitting capacity of the landfill serving the project area. Materials able to be recycled would be done to meet local standards regulating such activity. Operation of the proposed project would generate minimal solid waste associated with the use of the site; however, the minimal generation of waste would not affect solid waste statutes and regulations. Any solid waste generated during construction related activities would be recycled or disposed of in accordance with all applicable local, state and federal regulations.

XVIV. MANDATORY FINDINGS OF SIGNIFICANCE –

- a) Does the project have the potential to degrade the quality of the environment, substantially reduce the

Issue	Potentially Significant Impact	Less Than Significant with Mitigation Incorporated	Less Than Significant Impact	No Impact
-------	--------------------------------	--	------------------------------	-----------

habitat of a fish or wildlife species, cause a fish or wildlife population to drop below self-sustaining levels, threaten to eliminate a plant or animal community, reduce the number or restrict the range of a rare or endangered plant or animal or eliminate important examples of the major periods of California history or prehistory?

As noted above under the discussions for Biological Resources, Archaeological Resources and Tribal Cultural Resources, the project is located on a site where sensitive wetland and upland habitat and a recorded archaeological site that is also a significant Native American village site were impacted during unauthorized grading and placement of fill resulting in impacts requiring mitigation in accordance with CEQA and the City’s Land Development Code. This archaeological/tribal cultural resource site has yielded information that is important to the local Kumeyaay community in that it provides evidence of native use and habitation prior to the development of the area. As such, Tribal Consultation was conducted in accordance with AB52 which concluded that the grading associated with the project would have the potential to impact buried archaeological and tribal cultural resources. Impacts to biological resources were evaluated in accordance with the City’s MSCP Subarea Plan and Biology Guidelines and require mitigation. As such, implementation of the mitigation measures outlined in Section V of the MND would reduce potential impacts to Biological Resources, Archaeological Resources and Tribal Cultural Resources to below a level of significance.

b) Does the project have impacts that are individually limited, but cumulatively considerable? (“Cumulatively considerable” means that the incremental effects of a project are considerable when viewed in connection with the effects of past projects, the effects of other current projects, and the effects of probable futures projects)?

When viewed in connection with the effects of other projects in the area, construction of the project has the potential to impact archaeological and tribal cultural resources which could incrementally contribute to a cumulative loss of non-renewable resources. Cumulative impacts associated with loss of biological resources are covered under the MSCP Subarea Plan and mitigation assured through compliance with the City’s Biology

Issue	Potentially Significant Impact	Less Than Significant with Mitigation Incorporated	Less Than Significant Impact	No Impact
-------	--------------------------------	--	------------------------------	-----------

Guideline's and mitigation measures requiring restoration and on-site conservation. With implementation of the mitigation measures identified in Section V of the MND for Biological, Archaeological and Tribal Cultural Resources, this incremental impact would be reduced to below a level of significance.

c) Does the project have environmental effects, which will cause substantial adverse effects on human beings, either directly or indirectly?

As proposed, the proposed project does not have the potential to cause substantial adverse effects on human beings.

INITIAL STUDY CHECKLIST

REFERENCES

I. Aesthetics / Neighborhood Character

- City of San Diego General Plan.
- Community Plan.
- Local Coastal Plan.

II. Agricultural Resources & Forest Resources

- City of San Diego General Plan.
- U.S. Department of Agriculture, Soil Survey - San Diego Area, California, Part I and II, 1973.
- California Agricultural Land Evaluation and Site Assessment Model (1997)
- Site Specific Report:

III. Air Quality

- California Clean Air Act Guidelines (Indirect Source Control Programs) 1990.
- Regional Air Quality Strategies (RAQS) - APCD.
- Site Specific Report:

IV. Biology

- City of San Diego, Multiple Species Conservation Program (MSCP), Subarea Plan, 1997
- City of San Diego, MSCP, "Vegetation Communities with Sensitive Species and Vernal Pools" Maps, 1996.
- City of San Diego, MSCP, "Multi-Habitat Planning Area" Maps, 1997.
- Community Plan - Resource Element.
- California Department of Fish and Game, California Natural Diversity Database, "State and Federally-listed Endangered, Threatened, and Rare Plants of California," January 2001.
- California Department of Fish & Game, California Natural Diversity Database, "State and Federally-listed Endangered and Threatened Animals of California," January 2001.
- City of San Diego Land Development Code Biology Guidelines.

X Site Specific Reports: Biological Resources Letter Report Update for the Roselle Street Site, City of San Diego, California, APN: 340-080-40; Prepared for the City of San Diego (REC Consultants, Inc. July 2018); Biological Resources Letter Report for the Roselle Street Project Site, San Diego, California (Dudek, revised May 2009); Conceptual Wetlands Mitigation and Monitoring Report for the Roselle Street Project, City of San Diego, California (Dudek, April 2009).

V. Cultural Resources (includes Historical, Archaeological and Tribal Cultural Resources)

X City of San Diego Historical Resources Guidelines.

X City of San Diego Archaeology Library.

X Historical Resources Board List.

Community Historical Survey:

X Site Specific Reports: Updated Record Search and Literature review by qualified City archaeological staff (March 2019/September 2018); Tribal Consultation (October 2017); 10325 Roselle Street, Cultural Resources Report Addendum (Helix Environmental Planning, Inc. 2017 and 2015); Archaeological Resources on a Lot on Roselle Street, San Diego, California (including ADRP, Affinis, 2009).

VI. Geology/Soils

X City of San Diego Seismic Safety Study, 2008.

X U.S. Department of Agriculture Soil Survey – San Diego Area, California, Part I and II, December 1973 and Part III, 1975 via <http://websoilsurvey.nrcs.usda.gov/app/HomePage.htm>.

X State of California Earthquake Fault Zones Maps, Point Loma Quadrangle, May 2003.
Site Specific Reports:

VII. Greenhouse Gas Emissions

X Site Specific Report: “Roadway Construction Emissions Model, Version 7.1.5.1” prepared for UU27, UU437, UU598, October 2015.

VIII. Hazards and Hazardous Materials

X San Diego County Hazardous Materials Environmental Assessment Listing

San Diego County Hazardous Materials Management Division

X FAA Determination

State Assessment and Mitigation, Unauthorized Release Listing, Public Use Authorized.

Airport Land Use Compatibility Plan.

Site Specific Report:

IX. Hydrology/Water Quality

Flood Insurance Rate Map (FIRM).

Federal Emergency Management Agency (FEMA), National Flood Insurance Program - Flood Boundary and Floodway Map.

Clean Water Act Section 303(b) list, http://www.swrcb.ca.gov/tmdl/303d_lists.html).

Site Specific Reports: Drainage Study For: Roselle Street San Diego, CA (Stevens-Cresto Engineering, Inc. 2015); Water Quality Technical Report for Storm Water Runoff from Roselle Street (Stevens-Cresto Engineering, Inc. 2015)

X. Land Use and Planning

City of San Diego General Plan.

Community Plan.

Airport Land Use Compatibility Plan

City of San Diego Zoning Maps

FAA Determination

XI. Mineral Resources

California Department of Conservation - Division of Mines and Geology, Mineral Land Classification.

Division of Mines and Geology, Special Report 153 - Significant Resources Maps.

California Geological Survey - SMARA Mineral Land Classification Maps.

Site Specific Report:

XII. Noise

City of San Diego General Plan.

Community Plan

San Diego International Airport Master Plan CNEI Maps.

MCAS Miramar ACLUP

Brown Field Airport Master Plan CNEI Maps.

- Montgomery Field CNEL Maps.
- San Diego Association of Governments - San Diego Regional Average Weekday Traffic Volumes.
- San Diego Metropolitan Area Average Weekday Traffic Volume Maps, SANDAG.
- City of San Diego General Plan.
- Site Specific Report:

XIII. Paleontological Resources

- City of San Diego Paleontological Guidelines.
- Deméré, Thomas A., and Stephen L. Walsh, "Paleontological Resources City of San Diego," Department of Paleontology San Diego Natural History Museum, 1996.
- Kennedy, Michael P., and Gary L. Peterson, "Geology of the San Diego Metropolitan Area, California. Del Mar, La Jolla, Point Loma, La Mesa, Poway, and SW 1/4 Escondido 7 1/2 Minute Quadrangles," California Division of Mines and Geology Bulletin 200, Sacramento, 1975.
- Kennedy, Michael P., and Siang S. Tan, "Geology of National City, Imperial Beach and Otay Mesa Quadrangles, Southern San Diego Metropolitan Area, California," Map Sheet 29, 1977.
- Site Specific Report:

XIV. Population / Housing

- City of San Diego General Plan.
- Community Plan.
- Series 11 Population Forecasts, SANDAG.
- Other:

XV. Public Services

- City of San Diego General Plan.
- Community Plan.

XVI. Recreational Resources

- City of San Diego General Plan.
- Community Plan.
- Department of Park and Recreation

___ City of San Diego - San Diego Regional Bicycling Map

___ Additional Resources:

XVII. Transportation / Circulation

___ City of San Diego General Plan.

___ Community Plan.

___ San Diego Metropolitan Area Average Weekday Traffic Volume Maps, SANDAG.

___ San Diego Region Weekday Traffic Volumes, SANDAG.

___ Site Specific Report:

XVIII. Tribal Cultural Resources

X City of San Diego Historical Resources Guidelines.

X City of San Diego Archaeology Library.

___ Historical Resources Board List

___ Site Specific Report: Updated Record Search and Literature review by qualified City archaeological staff (March 2019/September 2018); Tribal Consultation (October 2017); 10325 Roselle Street, Cultural Resources Report Addendum (Helix Environmental Planning, Inc. 2017 and 2015); Archaeological Resources on a Lot on Roselle Street, San Diego, California (including ADRP, Affinis 2009).

XVIX. Utilities

X City of San Diego General Plan.

X Community Plan.

___ Site Specific Report:

XX. Water Conservation

___ City of San Diego General Plan.

___ Community Plan.

___ Sunset Magazine, New Western Garden Book. Rev. ed. Menlo Park, CA: Sunset Magazine.

___ Site Specific Report:

Created October 2016