

FIRE HYDRANT INSTALLATION

ITEM NO.	DESCRIPTION	ITEM NO.	DESCRIPTION
1	6" WET BARREL FIRE HYDRANT	5	6" CAST IRON EXTENSION NON-GROOVED SPOOL - AS REQUIRED (F, F)
2	.75" X 3.5" MIN HEX HEAD BREAKAWAY (SHEAR) BOLTS AND NUTS (ASTM A307) SHALL BE 3/4" NC THREAD. HEX HEAD ON TOP OF FLANGES (ALL)	6	6" LONG RADIUS DI-BASE ELBOW (F, PO / MJ)
3	6" CAST IRON BREAKAWAY SPOOL WITH 0.25"-V (SINGLE OR DOUBLE) BREAK OFF GROOVE	7	CONCRETE THRUST BLOCK
4	4' X 4' X 4" THICK CONCRETE PAD WITH 6" X 12" DEEP THICKENED EDGE AROUND PERIMETER OF CONCRETE PAD	8	COLD JOINT STRIP
		9	PIPE - 6" C-900 PVC
		10	GATE WELL WITH CAP
		11	6" GATE VALVE (F/MJ, F)
		12	TEE - SIZE X 6" (MJ, MJ, F)

NOTES:

- NUMBER OF OUTLETS SHALL BE AS SHOWN ON THE PLANS.
- CONNECT TO BASE OF THE HYDRANT WITH SHEAR BOLTS INSTALLED WITH HEX HEAD ON TOP OF THE FLANGE. (31/64" DIAMETER HOLE 2" DEEP IN BOLTS, GALVANIZED AFTER BORING)

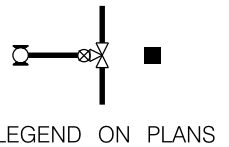

SHEET 1 OF 3

REVISION	BY	APPROVED	DATE	CITY OF SAN DIEGO - STANDARD DRAWING	RECOMMENDED BY THE CITY OF SAN DIEGO STANDARDS COMMITTEE
ORIGINAL	KA	J. NAGELVOORT	01/12		
UPDATED	KA	J. NAGELVOORT	08/13	FIRE HYDRANT INSTALLATION	COORDINATOR R.C.E. 56523 DATE
					DRAWING NUMBER SDW-104

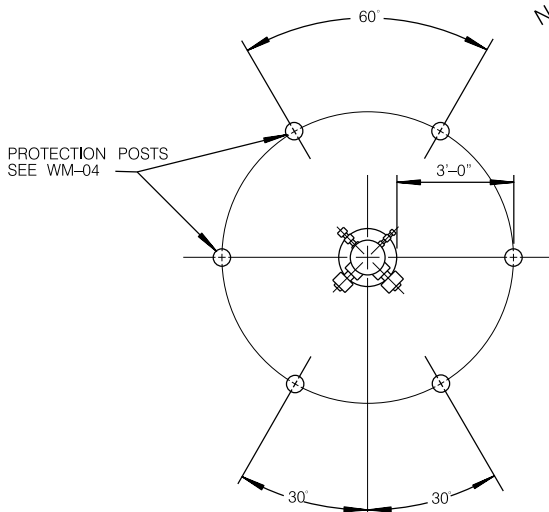
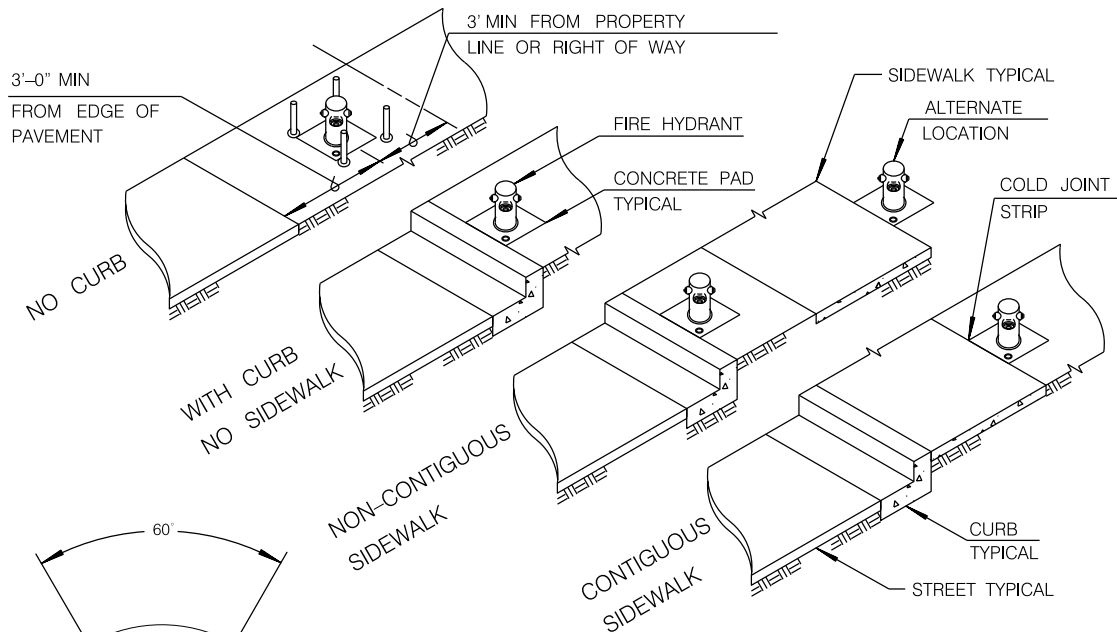

NOTE:

WHEN REQUIRED, NUMBER OF POSTS AND LOCATION TO BE SHOWN ON THE PLANS.

PROTECTION POSTS

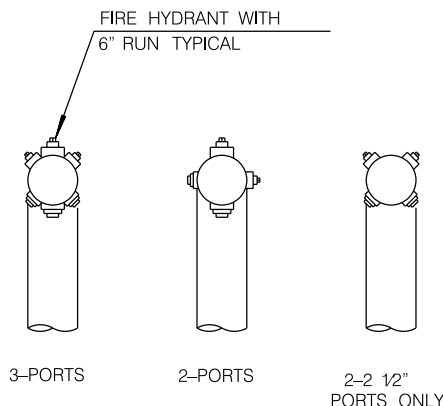

PORT ORIENTATION

FIRE HYDRANT LOCATIONS AND PORT ORIENTATION

NOTES:

- 1) LOCATE FIRE HYDRANT AS SHOWN ABOVE OR AS DIRECTED BY THE ENGINEER.
- 2) FIRE HYDRANTS SHALL BE INSTALLED WITH THE LARGEST PORT PERPENDICULAR TO THE STREET.
- 3) IF THE CONCRETE SLAB IS TO BE INSTALLED ADJACENT TO A CONCRETE CURB OR SIDEWALK, A COLD JOINT STRIP SHALL BE INSTALLED.
- 4) CONCRETE APRON SHALL BE REQUIRED WHERE THE FIRE HYDRANT IS INSTALLED IN AN UNPAVED LOCATION. THE APRON SHALL BE 4" THICK 520-C-2500 CONCRETE.
- 5) WHEN DISTANCE FROM THE FIRE HYDRANT TO THE TOP OR TOE OF THE SLOPE OR WALLS IS LESS THAN 2', SPECIAL HYDRANT INSTALLATION DETAIL SHALL BE SHOWN ON THE PLANS.
- 6) THE DISTANCE FROM THE FACE OF THE CURB TO THE CENTERLINE OF THE FIRE HYDRANT SHALL BE 2 1/2' MINIMUM.

SHEET 2 OF 3

REVISION	BY	APPROVED	DATE
ORIGINAL	KA	J. NAGELVOORT	01/12
UPDATED	KA	J. NAGELVOORT	08/13

CITY OF SAN DIEGO – STANDARD DRAWING

**FIRE HYDRANT
INSTALLATION**

RECOMMENDED BY THE CITY OF SAN DIEGO
STANDARDS COMMITTEE

CA Branga 9/9/2013

COORDINATOR R.C.E. 56523 DATE

DRAWING NUMBER **SDW-104**

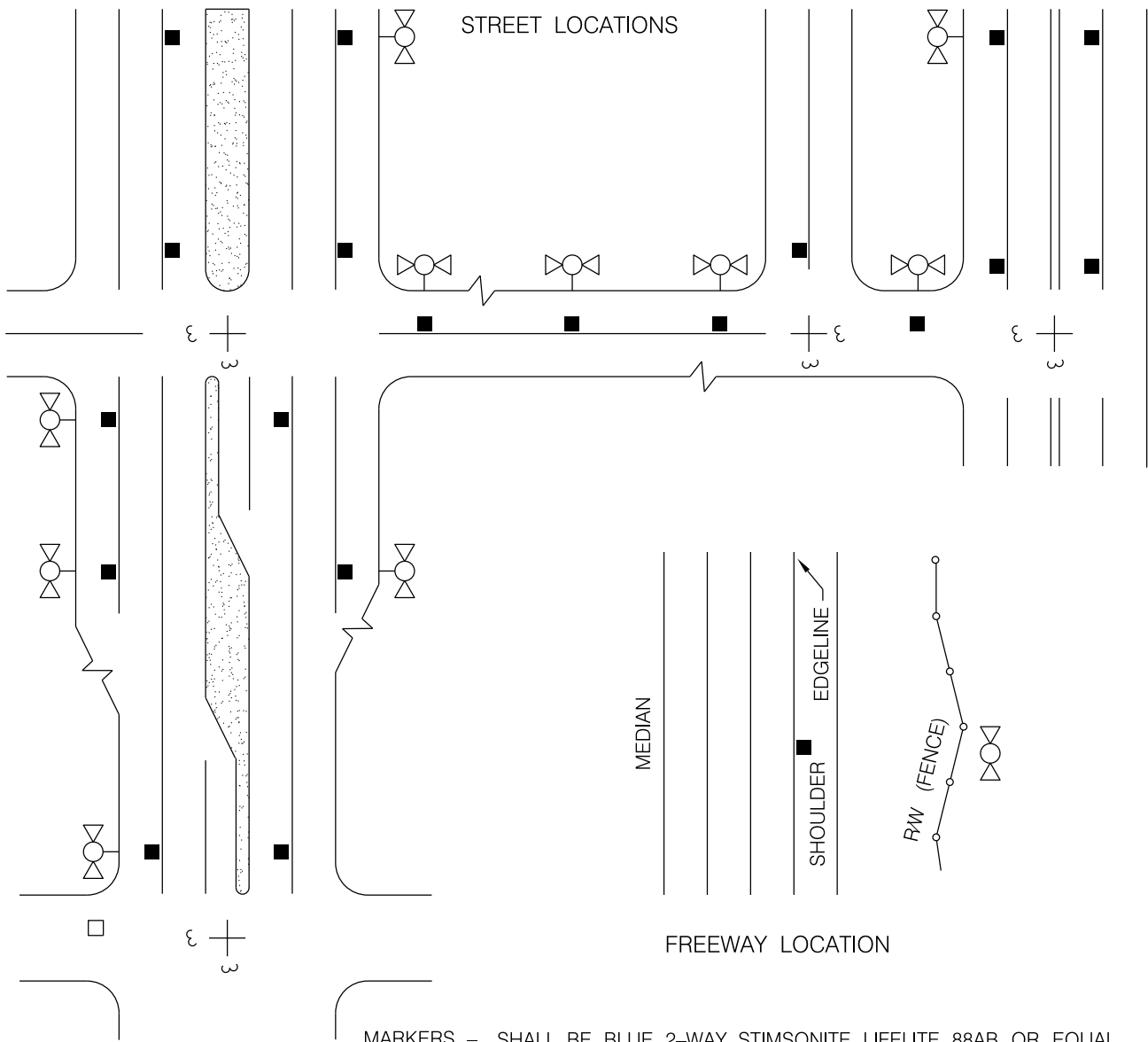

MARKERS – SHALL BE BLUE 2-WAY STIMSONITE LIFELITE 88AB OR EQUAL.
 ADHESIVE – AN AMPLE AMOUNT OF 2 (A&B) EPOXY OR EQUAL.
 SURFACES – CLEAN AND DRY TO INSTALLATION PER MANUFACTURER'S RECOMMENDATIONS.
 INSTALL MARKERS WITH REFLECTIVE SURFACES FACING ONCOMING VEHICLES AND OFFSET 2" FROM LANE LINES TOWARD FIRE HYDRANT.

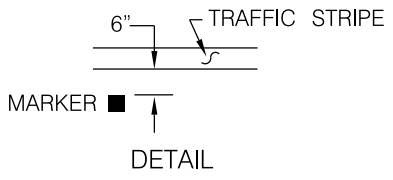

FIRE HYDRANT MARKERS

NOTES

1. FIRE DEPARTMENT WILL PROVIDE LOCATION(S) FOR ALL MARKERS IN PRD'S COMMERCIAL LOTS AND OTHER AREAS OUTSIDE OF PUBLIC RIGHT OF WAY.
2. MARKERS SHALL BE INSTALLED AT THE NEW AND RELOCATED HYDRANTS AND WITHIN ALL RESURFACING PROJECTS.
3. FOR STREETS WITHOUT LANE LINES OR STREETS WITH RAISED PAVEMENT MARKERS AND NO PAINTED LANE LINES, INSTALL MARKERS 6" FROM CENTERLINE OR EXISTING MARKERS.

REVISION	BY	APPROVED	DATE	CITY OF SAN DIEGO – STANDARD DRAWING	RECOMMENDED BY THE CITY OF SAN DIEGO STANDARDS COMMITTEE	
ORIGINAL	KA	J. NAGELVOORT	01/12		<i>CA Branga</i>	99/2013
UPDATED	KA	J. NAGELVOORT	08/13		COORDINATOR	R.C.E. 56523 DATE
				FIRE HYDRANT INSTALLATION	DRAWING NUMBER SDW-104	