



# **SOUTH BAY OCEAN OUTFALL ANNUAL INSPECTION REPORT**

## **2019**

### **South Bay Water Reclamation Plant**

Order No. R9-2013-0006 (NPDES No. CA0109045)

### **USIBWC South Bay International Wastewater Treatment Plant**

Order R9-2014-0009 (NPDES No. CA0108928)

Environmental Monitoring and Technical Services  
2392 Kincaid Road • Mail Station 45A • San Diego, CA 92101  
Tel (619) 758-2300 Fax (619) 758-2309



This report summarizes the results of the 2019 South Bay Ocean Outfall (SBOO) annual inspection. The inspection was completed on September 16, 2019, by City of San Diego (City) Ocean Monitoring Program personnel (Public Utilities Department). This report was completed to ensure compliance with the following:

- (1) Lease No. PRC 7888.9 issued by the California State Lands Commission.
- (2) Order No. R9-2013-0006 (as amended) for the City's South Bay Water Reclamation Plant (NPDES No. CA0109045).
- (3) Order R9-2014-0009 (as amended) for the United States Section of the International Boundary and Water Commission's South Bay International Wastewater Treatment Plant (NPDES No. CA0108928).

## **DESCRIPTION AND BACKGROUND**

### **Historical Background**

The SBOO discharges commingled effluent from the City's South Bay Water Reclamation Plant (SBWRP) and the South Bay International Wastewater Treatment Plant (SBIWTP), which is owned and operated by the U.S. Section of the International Boundary and Water Commission (USIBWC). The areas served by these facilities include eastern Tijuana, tributary to Tijuana Pump Station Number One, San Ysidro, tributary to the Grove Avenue Pump Station, and other local South Bay communities.

Construction of the South Bay Land Outfall (SBLO) began in 1991 and was finished in 1994. Building the offshore portion of the SBOO commenced during the fourth quarter of 1995 and the onset of SBIWTP effluent discharge from the SBOO was January 13, 1999. The SBWRP went online and began discharging effluent via the SBOO on May 6, 2002.

The SBOO discharges combined effluent from the SBWRP and the SBIWTP at approximately 3.5 statute miles offshore of Imperial Beach, CA, at an approximate depth of 90 ft below mean sea level, at a minimum initial dilution of 100:1 (see Appendix A.1). The partial tunnel/conventional seafloor configuration was chosen because overall construction and environmental mitigation costs were lower, and more efficient, than other available options. It is important to note that the tunnel does not extend all the way to the diffusers, due to the westerly drop off of the San Diego Formation (SDF), a favorable tunneling geology. Lowering the tunnel to remain within the SDF would have exceeded the capability of tunneling technology at the time of construction. Therefore, the decision was made to construct a riser assembly conduit at one of the offshore boring locations, and to also build a conventional seafloor configuration in order to achieve the desired depth and location for effluent discharge.

The functions and capabilities of the SBOO are multifaceted, and include: effluent distribution; emergency and controlled Tijuana River channel effluent discharge; return of effluent to Mexico; excess potential energy dissipation; back-flow prevention and conduit isolation for energy dissipation baffle and conduit maintenance; enhanced entrained air and gas removal; SBLO back-flow prevention during high- tide and low-flow conditions; maintenance access, corrosion monitoring and reduction measures; outfall back pressure detection, monitoring and recordation capabilities; conduit flushing; and outfall extension.

### **Outfall Description**

The SBOO starts from a drop shaft on land, approximately 1 mile inland from the ocean. The shaft drops vertically to a depth of 159 ft below sea level and proceeds offshore in an underground tunnel. The tunnel is 132 inches in diameter and follows the seabed grade at a slope of -0.3522% to a depth of approximately 214 ft below sea level. The tunnel ends approximately 19,000 ft from the drop shaft, where the riser structure begins and heads to the seafloor.

The seafloor portion of the SBOO was constructed by excavating a trench, then simultaneously placing the bedding stone and the pipe. Once completed, ballast and armor rock were added to the structure. The only visible features of the outfall include the armor rock, the riser assembly

shield, the six hatches along the Main Barrel, the gate covers of the Wye structure, the Diffuser Riser assemblies, and the Diffuser Leg Termination structures.

The outfall is approximately 4,691 ft long from the center of the riser shaft to the center of the Diffuser Wye (see Appendix A.2). The 120-inch inner diameter seabed pipe was constructed by excavating a trench, then simultaneously placing the bedding stone and the pipe sections. The pipe sections are constructed of reinforced concrete, bell and spigot pipe of the raised bell type, with two gaskets at each joint. The bells of the pipe face offshore. The pipe sits on a bedding of class 3 stone, which is covered with a minimum of 1-foot of class 2 ballast/filter stone, followed by a 3.5-foot armor layer of class 1 stone (see Appendix A.3). The alignment of the Main Barrel of the outfall is approximately  $210^{\circ}$  -  $215^{\circ}$  (south south-west facing), starts at a depth of 71 ft below sea level and ends approximately 90 ft below sea level.

The Main Barrel is completely covered in ballast rock, with the exception of the Inshore Riser Cover, the six maintenance access hatches (manholes), the Diffuser Risers, and the Diffuser Termination structures. The first manhole (station 190+30) is located in the center of the first pipe section next to the riser shaft (see Appendix A.4). There is a 2-foot diameter opening with a lid in the center of the riser. Armor stone is piled over the outfall pipe to just below the riser cover. Inside the riser is an air relief assembly that bleeds off excess air from the outfall pipe. There is a maintenance access hatch inside the riser that opens to the seabed pipe. The rest of the manholes are built in the same manner and accessed through risers (see Appendix A.5). A 10-inch thick reinforced concrete cover seals the 7 ft 6-inch outer diameter riser. Three lifting hooks are used to open the cover. The maintenance access hatch is located inside the riser. Approximately 5 ft of stone covers the seabed pipe around the riser cover.

The distance between each manhole is approximately 926 ft ( $\pm$  10 ft) (see locations in Table 1). The last manhole is located on the first pipe section inshore of the Diffuser Wye.

**Table 1**

Manhole locations along the SBOO.

Manhole*	Latitude	Longitude
1	32° 32.3439	117° 10.0918
2	32° 32.3255	117° 10.2855
3	32° 32.3089	117° 10.4636
4	32° 32.2930	117° 10.6414
5	32° 32.2760	117° 10.8197
6	32° 32.2591	117° 10.9988

\*Manhole No. 1 is offshore of the Inshore Riser Cover and Manhole No. 6 is immediately inshore of the diffuser at the Wye.

### *Diffusers*

The Diffuser Legs branch off from the main seabed pipe at the Diffuser Wye (station 236+98.67) (see Appendix A.6). The length of the Diffuser Wye section from bell end to bell end is 52 ft along the main axis of the seabed pipe. The angles between the north and south diffuser leg centerlines on the offshore ends and the Wye structure centerline are 77° and 74° respectively. The approximate alignments of the north and south Diffuser Legs are 340° (north facing) and 185° (south facing) respectively.

A 40-foot long offshore extension is connected to the Diffuser Wye and is completely buried under rock armor. A concrete pipe end plug seals the end of the pipe at station 237 + 63.54. If the outfall were ever to be extended, it would begin at this section.

There are three gates that can be used to stop flow between the main seabed pipe and Diffuser Legs and pipe end. The north Diffuser Leg and Offshore Extension gates are currently in place. Two Monel lifting hooks (1.5-inch diameter, 6-inch radius) are provided on each gate for their removal.

The length of each Diffuser Leg is 1,981 ft from the end of the Termination structure to the Wye centerline. The Diffuser sections have an 84-inch inner diameter where they connect to the Diffuser

Wye (station 0+00). At station 6+00 a 24-foot transition section reduces the pipe inner diameter to 72 inches. Another 24-foot transition section at station 12+24 further reduces the pipe inner diameter to 52-inch. The north and south Diffuser Legs end at station 19+81.00 and station 19+80.98, respectively. A 30-foot termination structure seals the end of each Diffuser Leg (see Appendix A.7) and a flap gate seals the 42-inch inner diameter pipe section of the termination structure. Rock ballast covers all of the termination structure, except for the flap gate and concrete support for the termination pipe.

Since the Diffuser Legs are buried, effluent from the outfall enters the ocean through diffuser riser assemblies which are bolted to the top of the Diffuser Leg conduits and to the Wye structure. The effluent rises vertically through the high-density polyethylene Diffuser Risers and transitions to horizontal discharge from a 1 ft 7.5-inch Diffuser Head with four ports. Each Diffuser Riser assembly is provided with a surrounding canister which protects it from the adjacent rock, and vessel anchors (see Appendix A.8).

There are 165 Diffuser Riser assemblies on the outfall; 82 on each Diffuser Leg and one at the intersection of the Wye structure. The risers are numbered sequentially, beginning at the Wye structure and referred with either “N” or “S” prefixes to indicate placement on the north or south Diffuser Legs. Thus, N1 is located adjacent to the Wye structure and N82 is located at the far end of the north Diffuser Leg. The Diffuser Riser at the Wye structure is simply designated as “W”. The Riser assemblies can be open (a head with four open and free-flowing ports), capped (a head with four temporarily- closed ports), or blind flanged (no head with a blind flange bolted to the upper flange of the riser assembly) (Table 2).

**Table 2**

Current Diffuser Riser configuration (A); flowrate allocation (in million gallons per day - mgd) and ownership (B).

<b>A</b>	<b>Open (Flow)</b>	<b>Capped (Temporarily Closed- No Flow)</b>	<b>Blind Flanged (No Flow)</b>
<b>North Diffuser Leg</b>			N1 - N82
<b>South Diffuser Leg</b>	S26, S52, S68 - S82	S51, S53 - S67	S1 - S25, S27 - S50
<b>Wye Structure</b>	W		
<b>Number</b>	18 Diffuser Risers (72 ports)	16 Diffuser Risers (64 ports)	131 Diffuser Risers (no ports)
<b>Percentage</b>	10.91 %	9.70 %	79.39 %

<b>B</b>	<b>USIBWC</b>	<b>City of San Diego</b>	<b>Total</b>
<b>Average Flowrate</b>	100 mgd	74 mgd	174 mgd
<b>Peak Flowrate</b>	200 mgd	133 mgd	333 mgd †
<b>Ownership *</b>	60.06 %	39.94 %	100 %

\*Ownership of the South Bay Ocean Outfall is as shown, and is based upon the peak flowrates, however, ownership of the South Bay Land Outfall is shared equally.

†The total peak flowrate is based upon the addition of a future pump station. At present, the maximum gravity flowrate through the outfall is 258 mgd.

### ***Operation and Maintenance Responsibilities***

A Memorandum of Understanding (and two subsequent Amendments) between the USIBWC and the City was drafted, which summarizes the outfall-related operation and maintenance responsibilities. Briefly, the USIBWC is responsible for the land outfall east of the drop shaft, including the anti-intrusion structure and two valves, which are located on top of the drop shaft hatch cover; the City is responsible for the drop shaft and everything west of it, including all of the offshore components.

### ***Post Start-up Corrective Work***

Since the initial use of the outfall in early 1999, the City has administered two offshore corrective

work sessions and one onshore corrective work session. The offshore work sessions involved: (1) the installation of two Monel plugs in each of the maintenance access hatch covers 2, 3, and 4 to halt effluent leakage; (2) the temporary closure of 64 ports along the south Diffuser Leg. Corrective work onshore involved: (1) sealing the hatch covers on the anti-intrusion structure and the drop shaft; (2) sealing the concrete at the anti-intrusion structure; (3) improving overall structural anti-corrosion measures; (4) conducting minor induced pressure testing.

### ***Administrative Details***

The SBOO Mylar drawings are located on the Fifth Floor of the City of San Diego Development Services Department - Engineering Maps and Records Office, which is located at 1222 First Avenue; Mail Station 501; San Diego, CA 92101. Access can be arranged for reproduction capabilities, as required.

## **METHODS**

### **Survey Equipment**

#### ***City Monitoring Vessel***

The City's *M/V Oceanus* is a 48-foot, twin diesel engine-powered, aluminum hull, modified crew boat, with a rear-mounted hydraulic A-frame and a bow winch and fixed bow A-frame from which the clump weight is deployed. The vessel is used by the Public Utilities Department's Environmental Monitoring and Technical Services Division primarily as an ocean monitoring and outfall inspection platform.

#### ***Remotely Operated Vehicle (ROV)***

The external inspection of the PLOO was carried out using the City's SAAB Seaeye Falcon Remotely Operated Vehicle (ROV). This ROV is equipped with high sensitivity, and high resolution, color and low-light black and white video cameras for recording high quality footage of the outfall (inspection video footage is available upon request). It is also equipped with a digital sonar, and an ultra-short baseline tracking system, which uses acoustic telemetry to locate the position of the ROV relative to the support vessel in real time. In addition, the ROV is



equipped with a precision navigation and positioning system composed of a doppler velocity log (DVL).

### **Outfall Survey**

The ROV is deployed on designated outfall sites from the City's monitoring vessel, from which City staff can remotely orient the ROV to the designated survey area, based on Global Positioning System (GPS) coordinates. Once in the water, the ROV is kept on the surface and moved a distance of 150 ft from the bow of the ship. The umbilical is then attached to a 300 lb clump weight, which is slowly lowered through the water column. As the weight is lowered, the umbilical is attached to the winch line at standard increments. The ROV descends to the seafloor and the clump weight is deployed to a depth that is approximately 20 ft above the ROV. The outfall is located using the ROV's sonar system, and then the support vessel, and the ROV, are simultaneously moved into position to begin the inspection.

During the inspection process, the outfall Diffuser Risers were counted to determine progress. The north and south Diffuser Legs each have 82 risers between the terminus structure and Wye structure. In between risers, ballast rock covers the sea bottom. It is critical that the boat maintain similar progress to the ROV, which is accomplished using the tracking system. If the boat were to fall behind the ROV, it would pull the ROV off the bottom, which would require the inspection to start over from the beginning, or trace back the risers from the Wye, or terminus structure, to the last inspected riser.

The inspection began at the south Diffuser Leg terminus at a depth of 90 ft (27 m) and proceeded north toward the Wye over each of the diffusers to inspect the structural condition and acceptable functioning of the riser assemblies. At the Wye, the three gate covers were inspected, then the ROV was flown offshore to the end of the rock pile covering the short three-pipe section terminal extension of the outfall. The ROV was then returned to the Wye to begin the survey of the north Diffuser Leg. As the ROV was flown over the north Diffuser Leg, it was paused briefly to inspect each of the 82 blind flanged riser assemblies. At the end of the north Diffuser Leg, the condition of the terminus was inspected. To complete the survey, the ROV was repositioned at

the center Wye where it was directed inshore to inspect the condition of the ballast rock, manhole covers, and access hatches spaced at uniform intervals along the Main Barrel.

Inspection involved surveying the visible and buried underwater, exterior portions of the outfall, the south Diffuser Leg termination structure (terminus), the south Diffuser Leg, the Wye, the north Diffuser Leg and termination, the Main Barrel and the manhole covers and maintenance access hatches (numbered 6 to 1 proceeding inshore), and the riser assembly shield (see Appendix A.1).

## **OBSERVATIONS**

After careful review of the video recordings for the 2019 inspection, and a side by side comparison of the 2018 survey video, it appears that few, if any, changes in the overall condition of the outfall have occurred over the past year. Water clarity varied between surveys, averaging 15-20 ft of horizontal visibility in the offshore area and gradually decreasing to 10-15 ft or less while moving inshore. Also, the type and extent of algal and invertebrate growth varied considerably on the ballast rock, Riser assemblies, and the other exposed features of the outfall. However, the distribution of ballast rock along the outfall and indeed the placement of individual stones surrounding each Riser assembly seemed nearly identical. The Canting, or Leaning of certain Riser Heads on the north Diffuser Leg observed in 2018 also seemed unchanged (N9, N33, N45, and N61). The outfall was generally found to be in good condition, exhibiting few if any detectable differences from that observed in earlier inspections.

### **Main Barrel**

Understory algae was present but in low densities. The ballast coverage was complete and seemed no different from earlier surveys. The condition of all seven concrete access covers and their lifting eyes also appeared unchanged.

## Wye

The condition of the Wye was nearly identical to the previous surveys: the gate covers were in good condition and were sealed properly; the offshore rock pile was generally free of algal coverage, and the ballast coverage was complete with no visible bacterial mat. The Diffuser Wye had accumulated more encrusting growth, but the ports were all flowing freely.

## South Diffuser Leg

The Termination structure and the Flap Gate remained overgrown by algae and invertebrate, but overall it appeared to be in good condition. The Flap Gate did not exhibit any visible signs of leaking. The anode on the crossbar could not be evaluated because it continues to be obscured by encrusting marine growth. The southeast Diffuser Port on Riser S82 was completely blocked, but the other three ports were flowing normally. The other active Diffuser Heads had accumulated more invertebrate and algal growth since the last inspection, but their Diffuser Ports all looked to be flowing freely. The inactive Risers were all in good condition and appeared to be sealed properly. The ballast coverage along this structure was unchanged. Some of the Risers, such as S68, are not centered on their cans.

## North Diffuser Leg

The ballast covering this structure had not visibly changed. The Risers were all in good condition and sealed properly except for Riser N69. This structure continued to exhibit the telltale signs of leaking, a white patina of bacteria and the absence of sediment in the Riser Can, but it otherwise looked to be structurally sound. The persistent intrusion of sand along the northern half of the Diffuser Leg seemed no different from past years. The Termination structure remained in good condition and was properly sealed. The anode on the crossbar was difficult to see due to encrusting organisms, thus its condition could not be evaluated. As observed in prior years the Canting, or Leaning of certain Riser Heads was observed (N9, N33, N45, and N61).

## CONCLUSIONS

Comparison of videos between the 2019 and 2018 surveys show that the SBOO remains in overall good condition and continues to be structurally and functionally sound, with adequate, and unchanged, ballast coverage.

### Noteworthy Observations

- 1 The side by side comparison of the 2018 and the 2019 ROV inspection videos confirms that there has been no detectable change in the rock distribution over the north Diffuser Leg and also supports the notion that the localized areas of low rock distribution observed on this structure was likely an artifact of the construction process and not the result of external oceanographic forces.
- 2 Sand intrusion from offshore along the northern half of the north Diffuser Leg has persisted throughout the inspection period and continues to not pose a functional impairment to the outfall structure.
- 3 As in past surveys, active Diffuser Heads continue to accumulate large colonies of invertebrate organisms, but their Diffuser Ports have remained generally unobstructed and all appear to be functioning properly. City engineers have developed a scope of services for divers to clean the Diffuser Ports of the encrusting organisms.
- 4 The capped and blind flanged riser assemblies were observed to be in good condition and appear unchanged.
- 5 The cosmetic damage to some of the concrete cover structures noted in earlier surveys had not changed and the structures appear fundamentally sound.
- 6 The upgrade to secondary treatment at the IWTP in January 2011 has continued to

markedly improve the visible quality of discharged effluent and may have also been responsible for the virtual elimination of the bacterial mats seen near all points of discharge in the years predating the current review period.

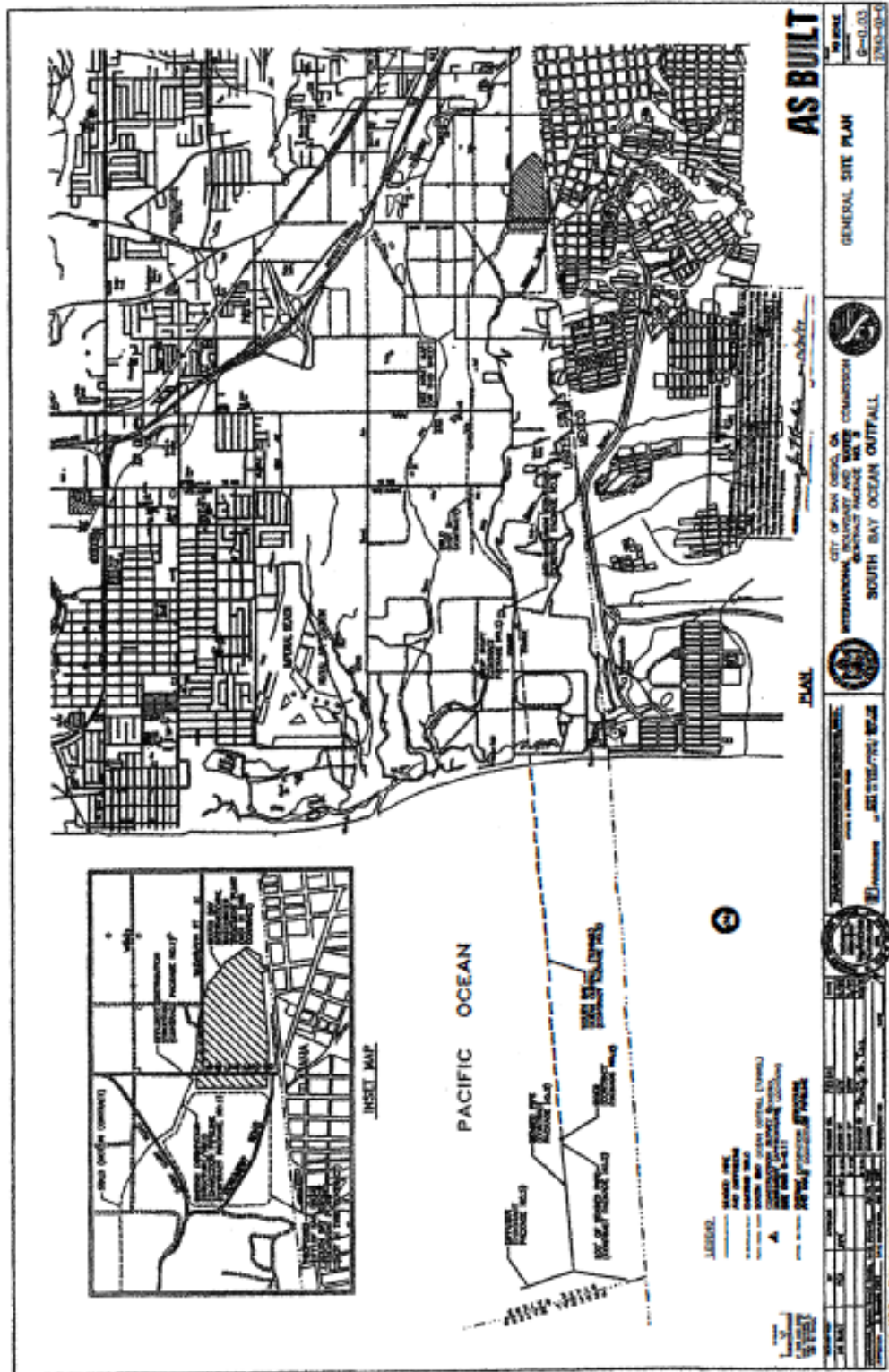

### Appendix A.1

Map of the land and Ocean based portions of the SBOO.

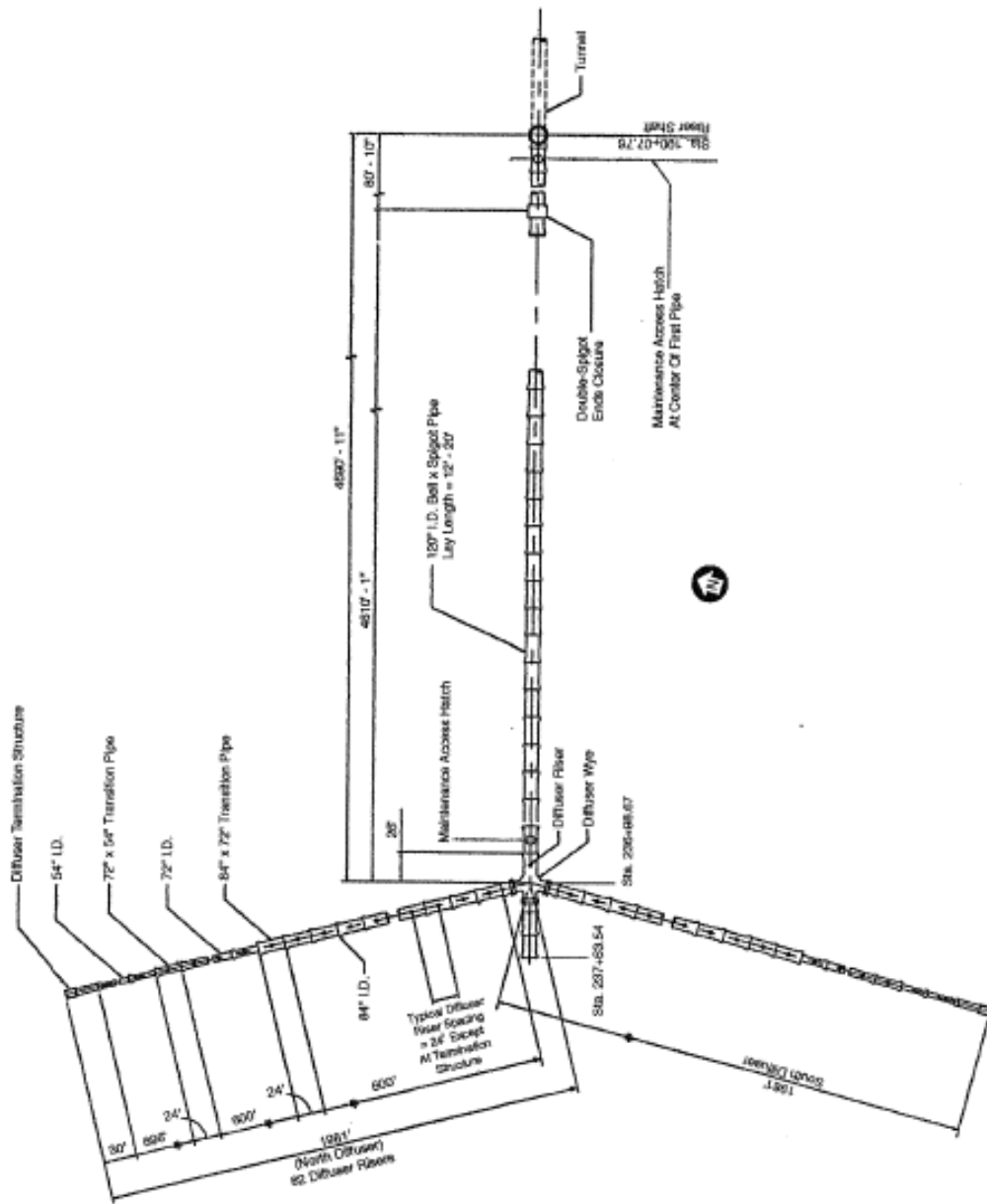

## Appendix A.2

The SBOO seabed pipe and diffusers.

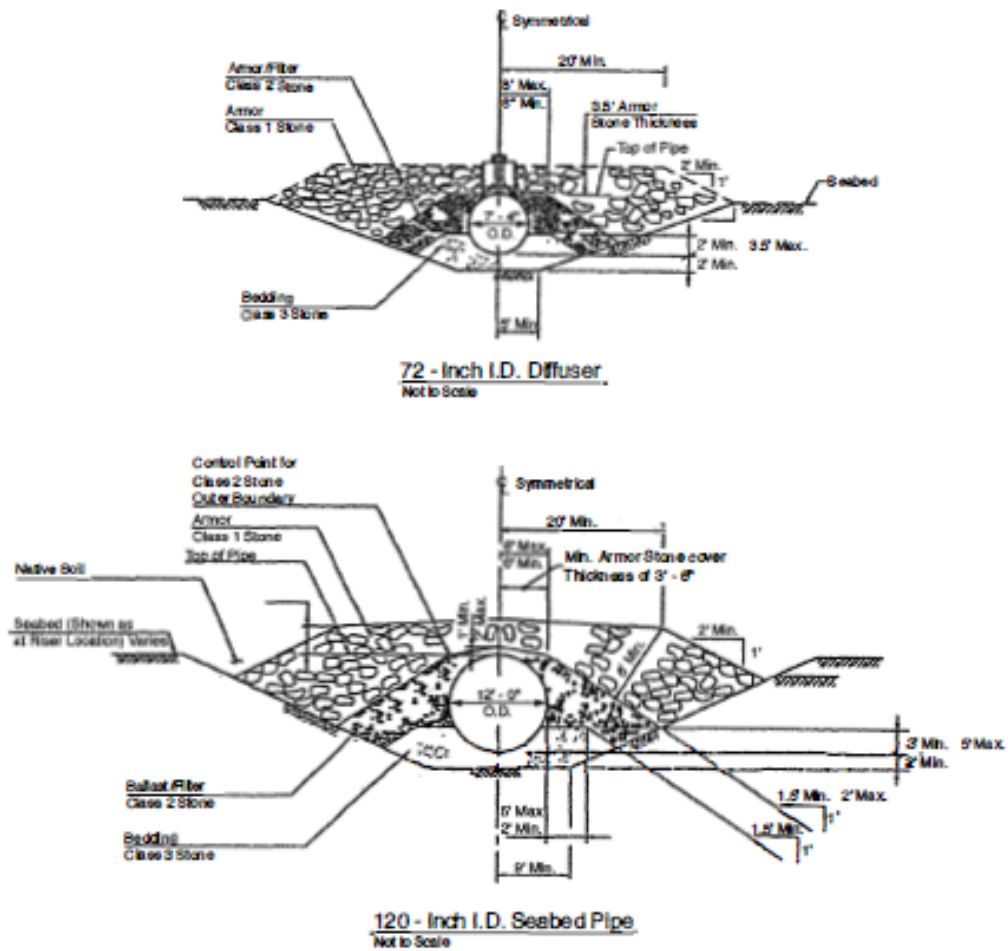

### Appendix A.3

Cross section of the SBOO and ballast rock.



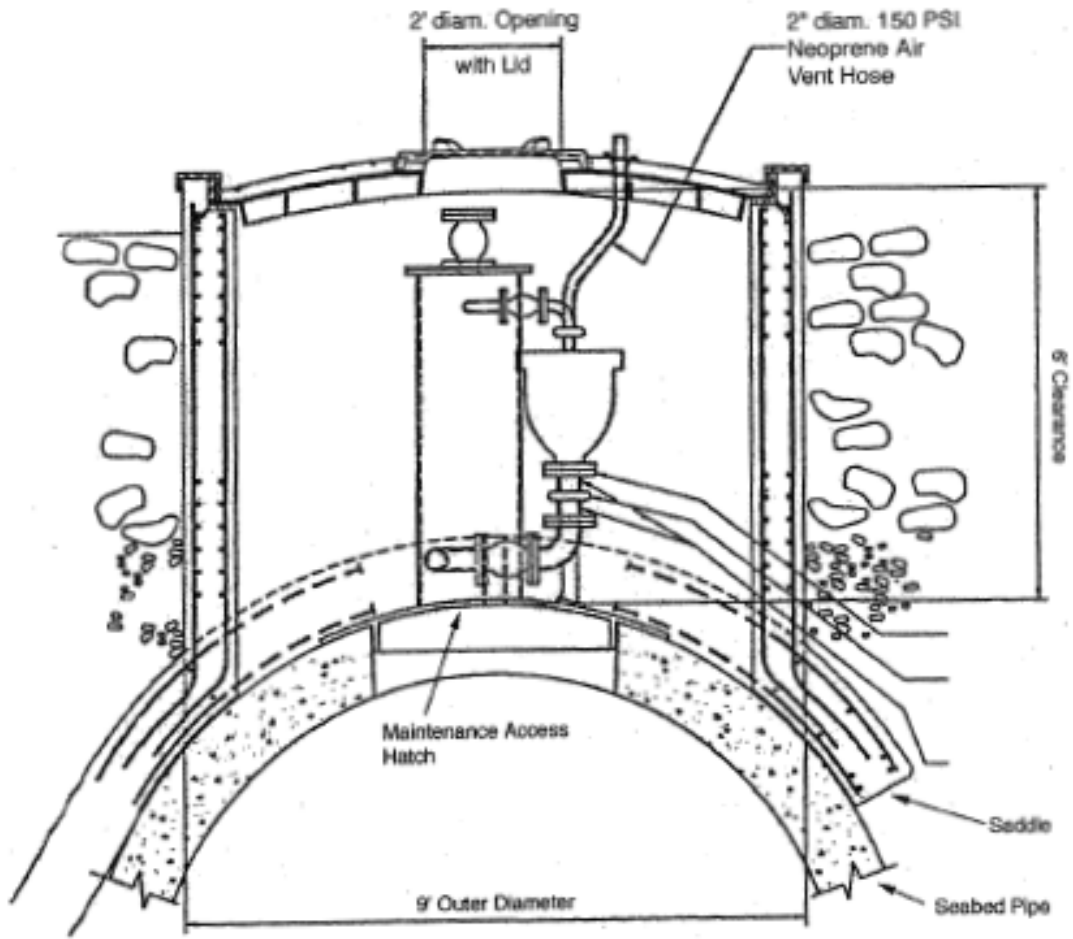

### Appendix A.4

Air relief assembly and maintenance hatch.

---

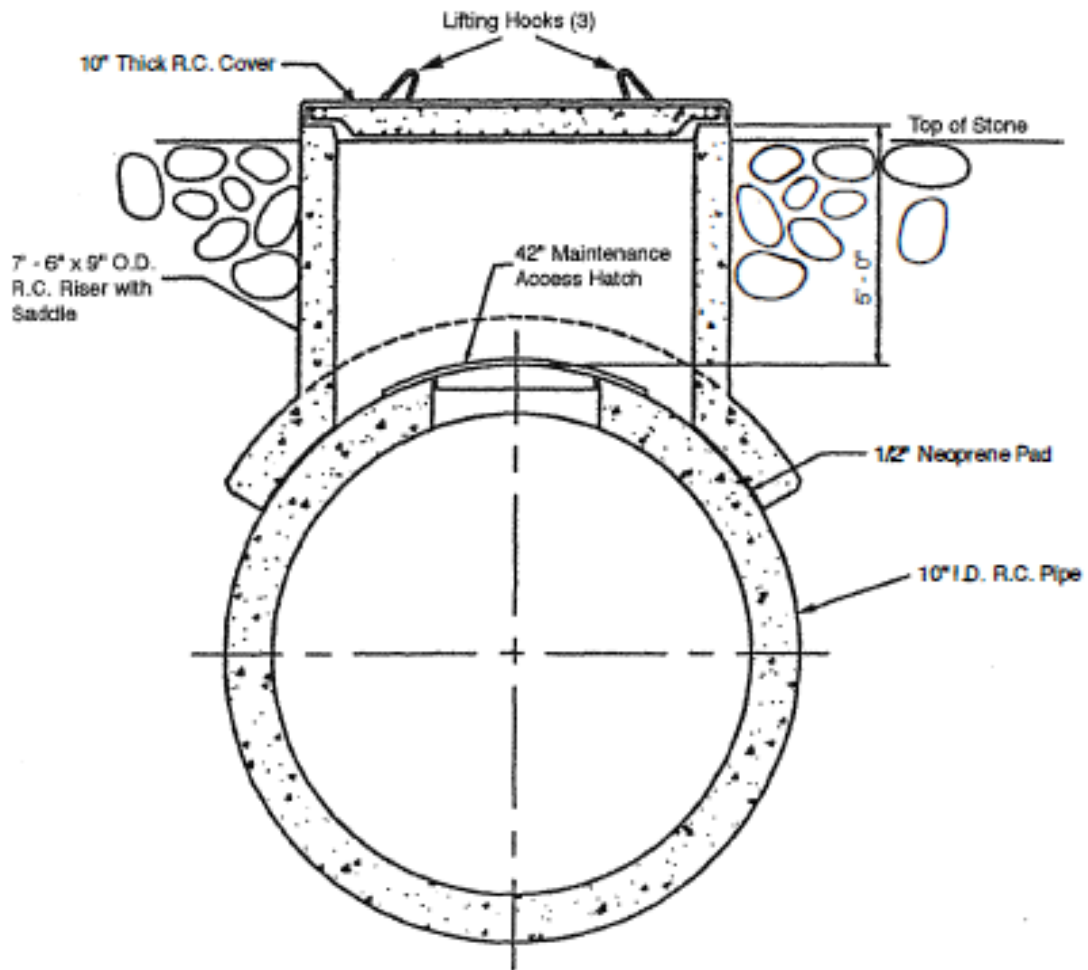

## Appendix A.5

Maintenance access hatch and riser.

---

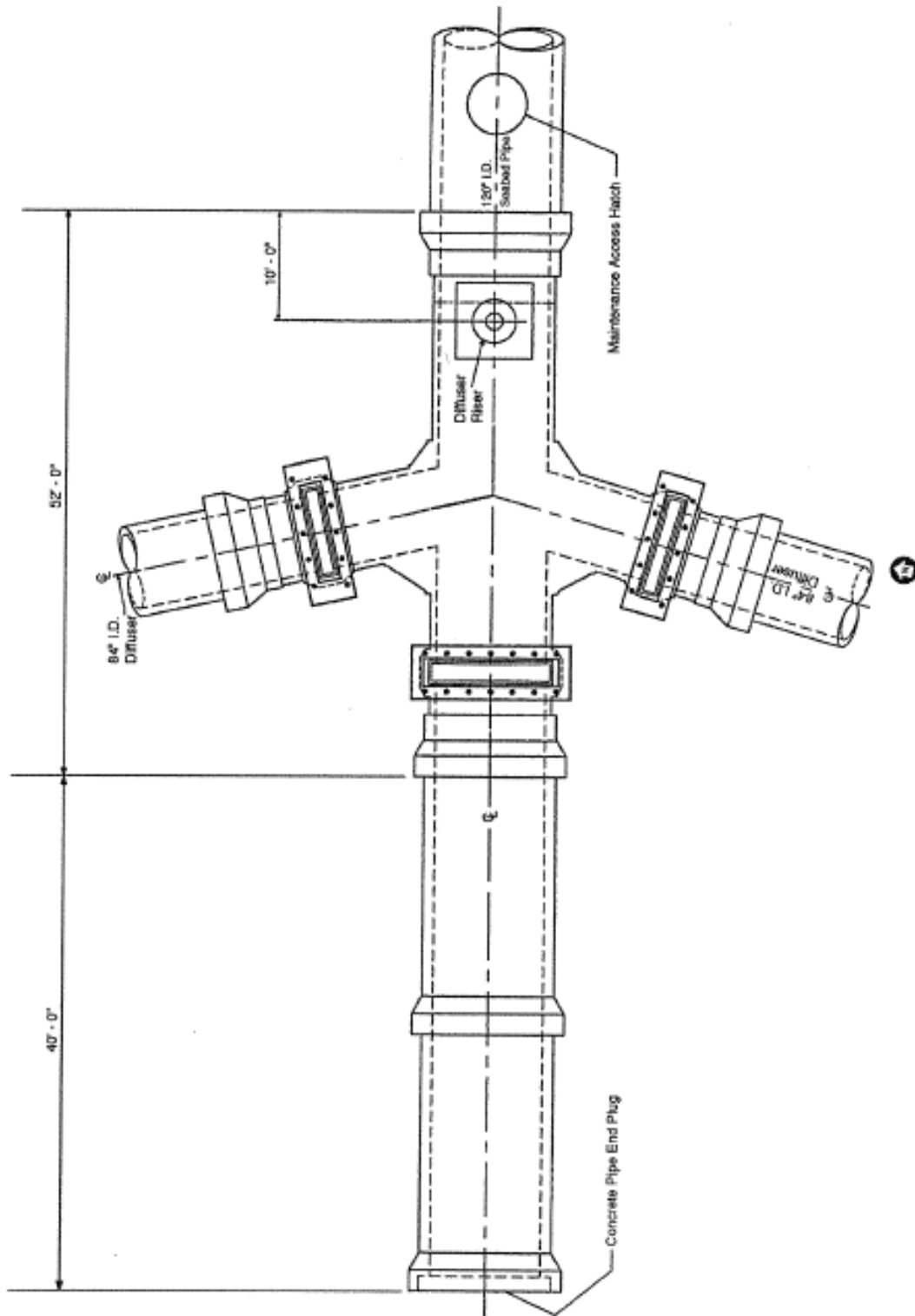

### Appendix A.6

The Diffuser Wye structure for the SBOO.

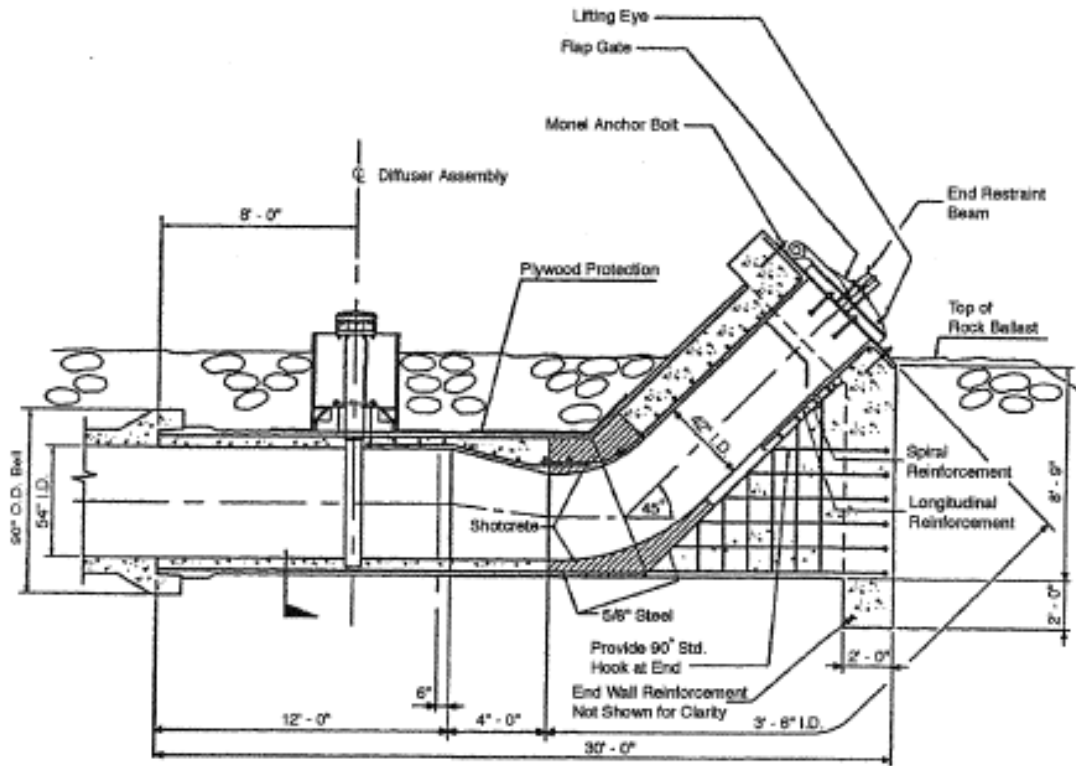

## Appendix A.7

Termination structure found at the end of the SBOO Diffuser Legs.

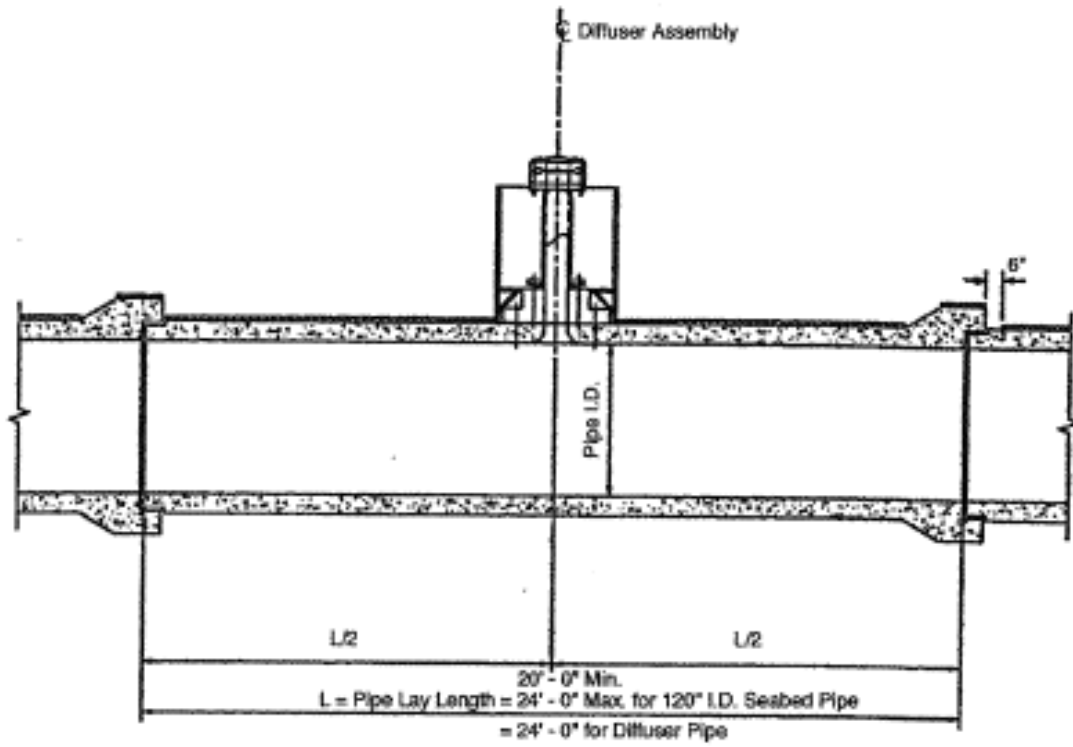

### Appendix A.8

Diffuser assembly on the SBOO Diffuser Legs.

---