

STREET

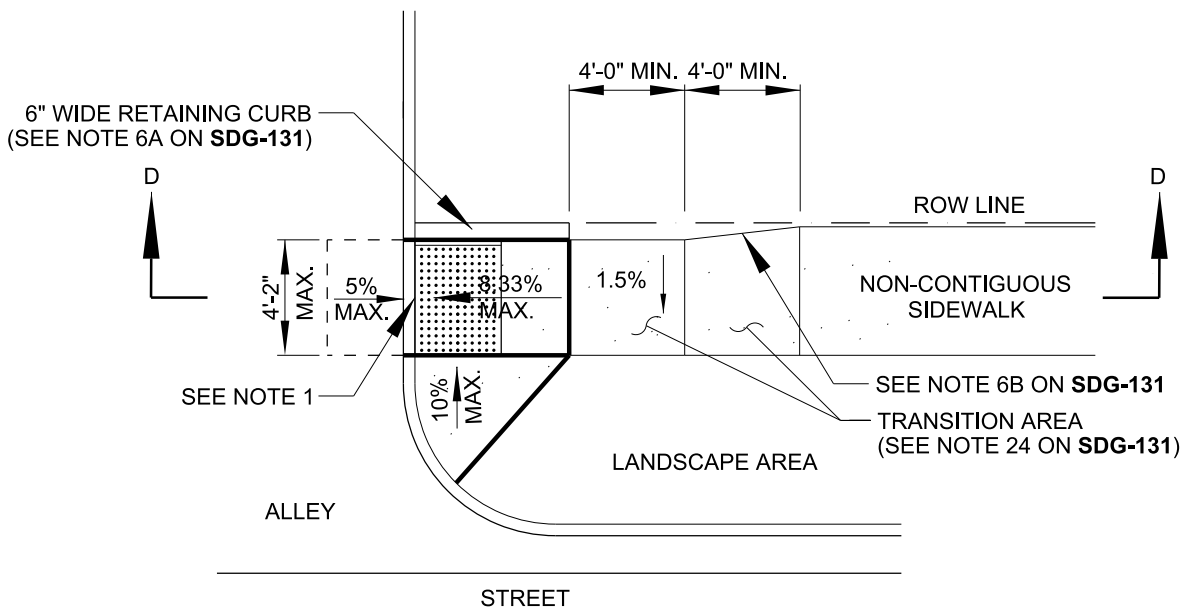

**PLAN - TYPE D**

SEE SHEET 2 FOR TYPICAL CROSS SECTION.

LEGEND: TOOLED JOINT

**NOTE:**

1. 4'-0" WIDE DETECTABLE WARNING TILE. WIDEN CURB RAMP WIDTH TO 4'-2" MAXIMUM TO ACCOMMODATE FORMWORK FOR THE 6" WIDE RETAINING CURB.

SHEET 1 OF 2

REVISION	BY	APPROVED	DATE
ORIGINAL	FC	J. NAGELVOORT	02/16
REDRAFTED	CD	J. NAGELVOORT	12/18
UPDATED	HN	J. NAGELVOORT	04/19
UPDATED	FC	J. NAGELVOORT	09/20

CITY OF SAN DIEGO – STANDARD DRAWING

**CURB RAMP - TYPE D**

RECOMMENDED BY THE CITY OF SAN DIEGO STANDARDS COMMITTEE  
  
 9/22/20  
 COORDINATOR R.C.E. 56523 DATE

DRAWING NUMBER **SDG-137**

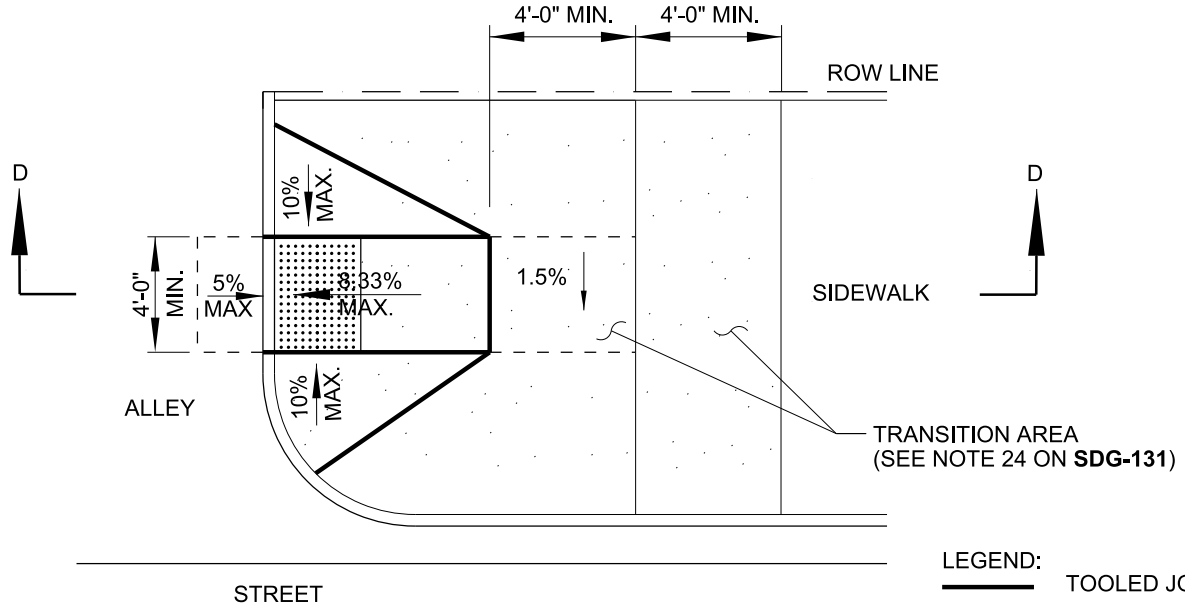
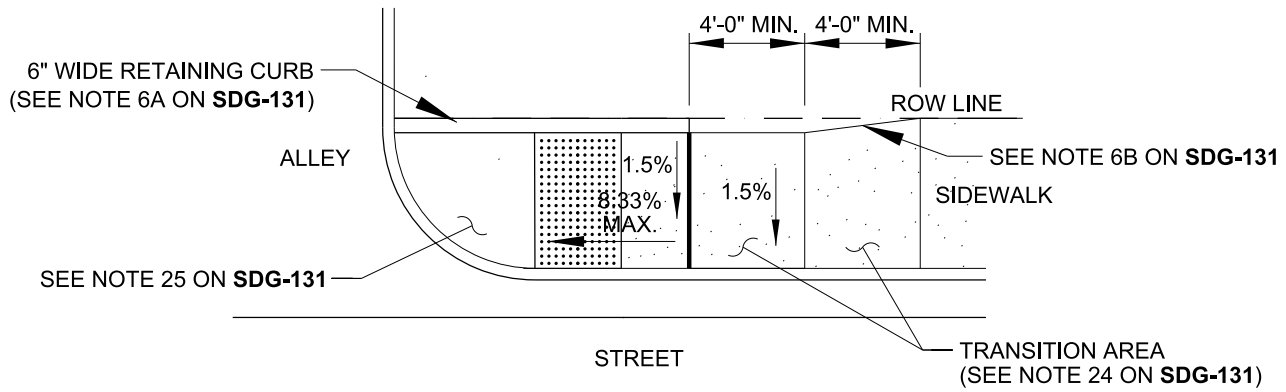

LEGEND:  
 TOOLED JOINT

**PLAN - TYPE D**

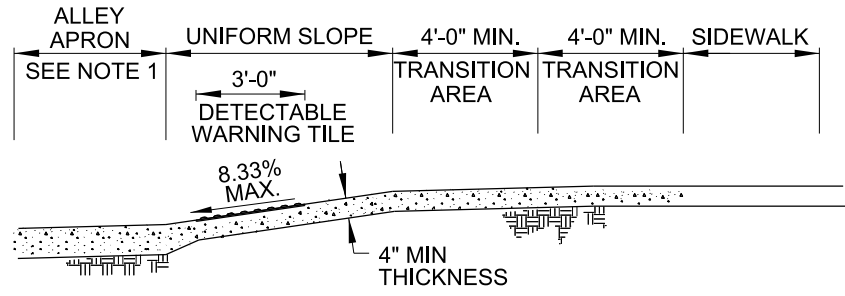

**SECTION D-D**

**NOTE:**

1. REFER TO **SDG-131** - NOTE 23 AND SDG-120 FOR ALLEY APRON REPLACEMENT.

REVISION	BY	APPROVED	DATE	CITY OF SAN DIEGO - STANDARD DRAWING	RECOMMENDED BY THE CITY OF SAN DIEGO STANDARDS COMMITTEE
ORIGINAL	FC	J. NAGELVOORT	02/16		<b>CURB RAMP - TYPE D</b>
REDRAFTED	CD	J. NAGELVOORT	09/18	COORDINATOR R.C.E. 56523	
UPDATED	HN	J. NAGELVOORT	04/19	DATE	
UPDATED	FC	J. NAGELVOORT	09/20		
					DRAWING NUMBER <b>SDG-137</b>