

NOTES:

1. INSTALL CORPORATION STOP WITH KEY IN THE SIDE POSITION.
2. SET TOP OF METER BOX FLUSH WITH SIDEALK, CURB, OR FINISH GRADE.
3. LOCATE METER BOX AS SHOWN ON WS-03
4. INSTALL WARNING/IDENTIFICATION TAPE PER SDM-105.
5. WATER LATERALS INSTALLED FOR THE USE OF RECYCLED WATER SHALL BE IDENTIFIED AS DESCRIBED IN SPECIFICATIONS.
6. SILVER SOLDER JOINTS SHALL NOT BE USED.
7. ON STEEL MAINS, USE WELD ON COUPLINGS. ON DUCTILE IRON, MAINS, USE DUCTILE IRON SERVICE SADDLES.
8. TOP TAPS ARE NOT PERMITTED, AND ANY GLUE JOINTS SHALL BE BEVELED PRIOR TO ASSEMBLY.
9. NO RECYCLED WATER SHALL ENTER INTO THE STORM DRAIN.
10. FOR STEEL AND DIMAINS, INSTALL DIELECTRIC UNION AFTER CORPORATION STOP.
11. WAX TAPE FROM MAIN TO 3" PAST DIELECTRIC UNION, INCLUDING SADDLE.

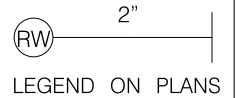

SHEET 1 OF 2

| ITEM NO | SIZE AND DESCRIPTION | ITEM NO | SIZE AND DESCRIPTION |
|---------|---|---------|--|
| ① | SIZE x 2" BRONZE SERVICE SADDLE (DOUBLE STRAP) | ⑥ | 2" BRONZE ANGLE METER STOP WITH LOCKWING |
| ② | RECYCLED WATER MAIN | ⑦ | WATER METER FURNISHED AND INSTALLED BY THE CITY |
| ③ | 2" BRONZE CORPORATION STOP | ⑧ | METER BOX WITH LID, 17"x 30" |
| ④ | 2" x REQUIRED LENGTH COPPER PIPE TYPE "K" SOFT/RIGID OR UNLESS OTHERWISE SPECIFIED. | ⑨ | CUSTOMER SHUT-OFF VALVE (LOCKABLE) |
| ⑤ | 38" ROCK, 4" TO 6" DEEP | ⑩ | 2" COPPER DIELECTRIC UNION. REQUIRED FOR STEEL OR DIMAINS. |

| | | | | | |
|---|----|---------------|-------|---|--|
| REVISION | BY | APPROVED | DATE | CITY OF SAN DIEGO – STANDARD DRAWING | RECOMMENDED BY THE CITY OF SAN DIEGO STANDARDS COMMITTEE |
| ORIGINAL | KA | J. NAGELVOORT | 01/12 | | |
| UPDATED | KA | J. NAGELVOORT | 08/13 | | |
| UPDATED | EF | J. NAGELVOORT | 11/17 | | |
| 2" RECYCLED WATER SERVICE INSTALLATION AND MARKING | | | |  COORDINATOR R.C.E. 56523 11/20/2017 DATE | |
| | | | | DRAWING NUMBER SDRW-102 | |

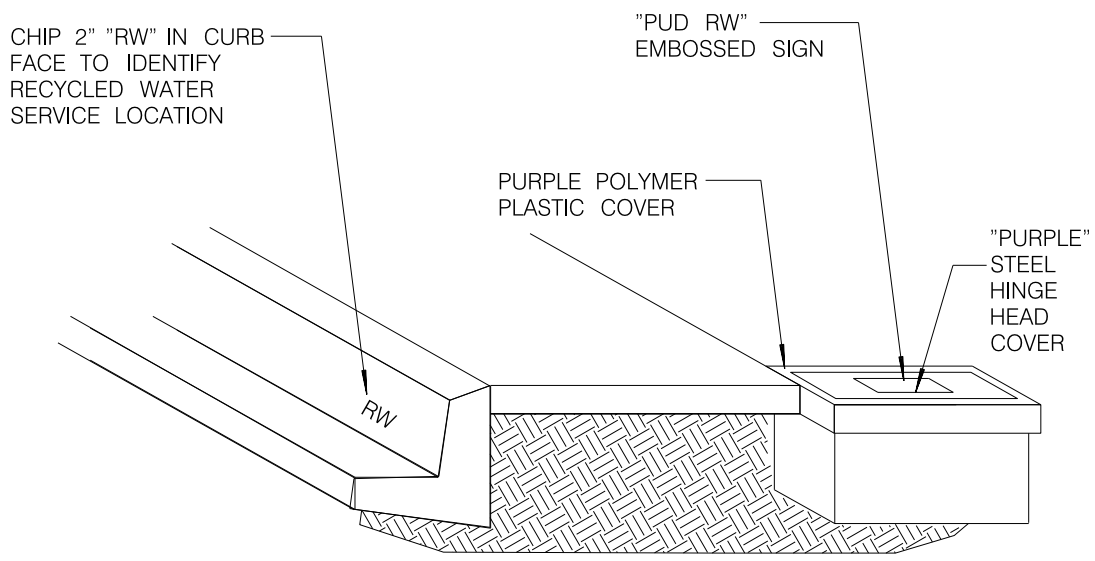

NOTES:

1. FOR ALL RECYCLED WATER SERVICE READING LID OF METER BOX SHALL BE PAINTED WITH PURPLE PANTONE #522 FOR ALL RECYCLED WATER SERVICE.
2. METER AND VALVES SHALL BE LABELED OR TAGGED TO INDICATE RECYCLED WATER.

| | | | | | |
|----------|----|---------------|-------|---|---|
| REVISION | BY | APPROVED | DATE | CITY OF SAN DIEGO – STANDARD DRAWING | RECOMMENDED BY THE CITY OF SAN DIEGO STANDARDS COMMITTEE |
| ORIGINAL | KA | A. OSKOUI | 01/12 | | <i>Chungee</i> 11/20/2017 COORDINATOR R.C.E. 56523 DATE |
| UPDATED | KA | J. NAGELVOORT | 08/13 | 2" RECYCLED WATER SERVICE INSTALLATION AND MARKING | DRAWING NUMBER SDRW-102 |
| UPDATED | EF | J. NAGELVOORT | 11/17 | | |
| | | | | | |