

INSTALL ENCLOSURE
TO SDW-117

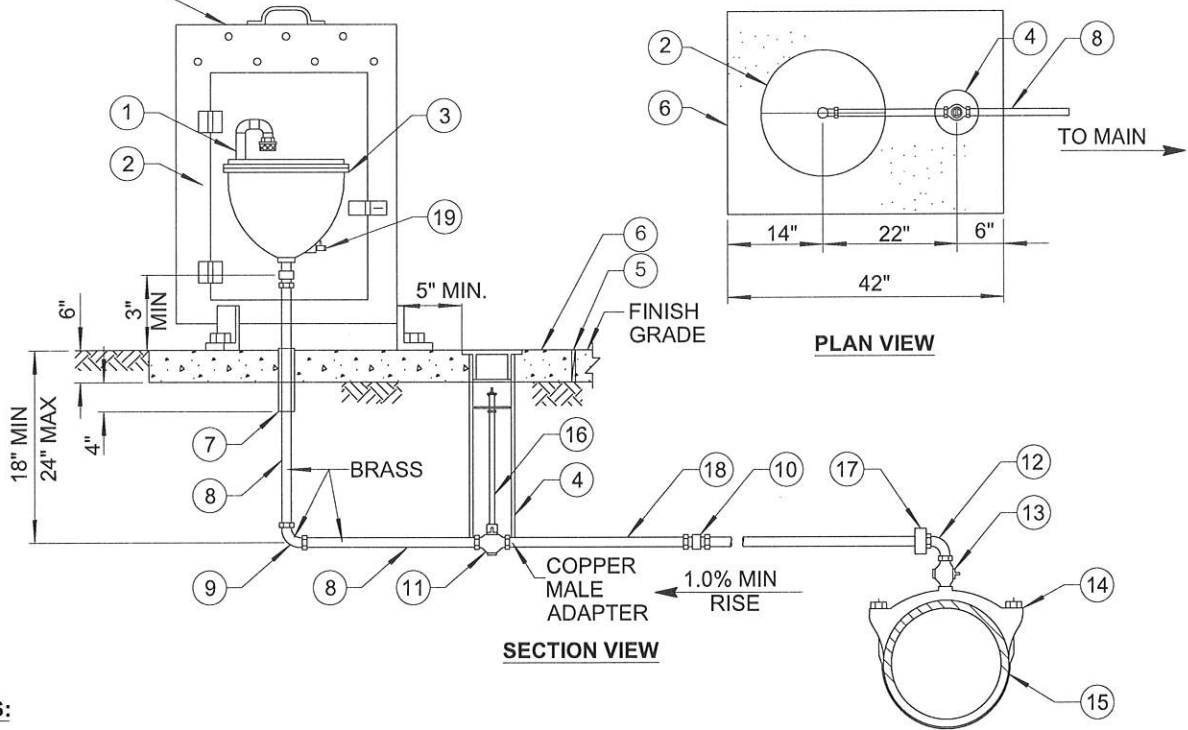

NOTES:

1. NO DIPS OR LOW SPOTS WILL BE ALLOWED IN INSTALLATION.
2. INSTALL ENCLOSURE PER SDW-117.
3. INSTALL WARNING/ IDENTIFICATION TAPE PER SDM-105.
4. AIR & VACUUM VALVE INSTALLED FOR THE USE OF POTABLE/ RECYCLED WATER SHALL BE SHOWN ON THE PLANS.
5. ON STEEL MAINS USE WELD ON COUPLINGS, ON DUCTILE IRON MAINS USE DUCTILE IRON SERVICE SADDLES.
6. FOR STEEL AND DI MAINS, INSTALL DIELECTRIC UNION AFTER CORPORATION STOP.
7. INSTALL WAX TAPE FROM MAIN TO 3" PAST DIELECTRIC UNION, INCLUDING SADDLE.

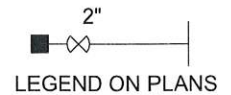

ITEM NO	SIZE AND DESCRIPTION	ITEM NO	SIZE AND DESCRIPTION
①	2" PVC SCH 80 CLOSE NIPPLE & 2-SCH 80 STREET ELLS & INSECT SCREEN.	⑩	2" BRONZE COMPRESSION COUPLING COPPER TO COPPER (IF REQUIRED).
②	APPROVED VALVE ENCLOSURE PER SDW-117.	⑪	2" COMP BALL VALVE THREADED ON BOTH SIDES.
③	2" AUTOMATIC COMBINATION AIR RELEASE & AIR/VACUUM VALVE.	⑫	2" 90 DEGREE BRONZE FIPT X COMP ELL.
④	8", OD STEEL GATE CASING WELL WITH CAP PER SDW-153.	⑬	2" BRONZE MIPT X MIPT CORPORATION STOP.
⑤	COLD JOINT STRIP.	⑭	SIZE X 2" SERVICE SADDLE.
⑥	3'-6" X 3'-6" X 6" THICK CONCRETE SLAB. CONCRETE SHALL BE 520-C-2500.	⑮	WATER MAIN.
⑦	2" X 1/2" BLACK FOAM SLEEVE.	⑯	VALVE STEM EXTENSION.
⑧	BRASS TUBING.	⑰	2" COPPER DIELECTRIC UNION. REQUIRED FOR STEEL OR DI MAINS.
⑨	90 DEGREE BRASS ELL (NO SWEAT, NO GLUED JOINTS ALLOWED).	⑱	1/4" PRESSURE PETCOCK.

REVISION	BY	APPROVED	DATE	CITY OF SAN DIEGO - STANDARD DRAWING	RECOMMENDED BY THE CITY OF SAN DIEGO STANDARDS COMMITTEE	
ORIGINAL	KA	J. NAGELVOORT	01/12			
UPDATED	BB	J. NAGELVOORT	09/14			
UPDATED	AR	J. NAGELVOORT	11/15			
UPDATED	HM	J. NAGELVOORT	02/16			
UPDATED	TP	J. NAGELVOORT	08/18			
UPDATED	RC	R. AMEN	08/22	2" AUTOMATIC COMBINATION AIR RELEASE & AIR/ VACUUM VALVE INSTALLATIONS	COORDINATOR R.C.E. 81047 DATE 9/12/22	
						DRAWING NUMBER SDW-159