

MATERIAL LIST

- ① CONCRETE TEST BOX, SDW128, FOR TEST BOX PLACEMENT **SEE WS-03**
- ② 2 - #8 AWG HMWPE WIRE WITH 18" OF SLACK WIRE AT PIPE CONNECTION AND 24" SLACK WIRE INSIDE TEST BOX
- ③ EXOTHERMIC WELD OR PIN BRAZE WIRE TO PIPE, **PER SDW-125**
- ④ WIRE TRENCH AND STREET REPAIRS **PER SDW-126 AND SDG117 OR SDG-118**
- ⑤ 6" WIDE, RED PLASTIC WARNING TAPE
- ⑥ SCH 40 PVC ELECTRICAL CONDUIT
- ⑦ METALLIC PIPE
- ⑧ ATTACH TO NEAREST PIPE JOINT WHEN POSSIBLE
- ⑨ GRADE XX PHENOLIC TERMINAL BOARD, 5"x 5"x 1/4"
- ⑩ WIRE LABEL **PER SDW-131**
- ⑪ STAINLESS STEEL BINDING POST TINKER & RASOR #164-060, PROMARK #PM-TS3-LUGS, OR EQUAL
- ⑫ 1/4" -20 STAINLESS STEEL NYLON INSERT LOCK NUT
- ⑬ 1/4" STAINLESS STEEL FLAT WASHER
- ⑭ CURB/GUTTER OR EDGE OF ROAD, **SEE NOTE 1 ON SHEET 2**
- ⑮ SIDEWALK OR STEEL REINFORCED CONCRETE COLLAR, **SEE NOTE 1 ON SHEET 2**

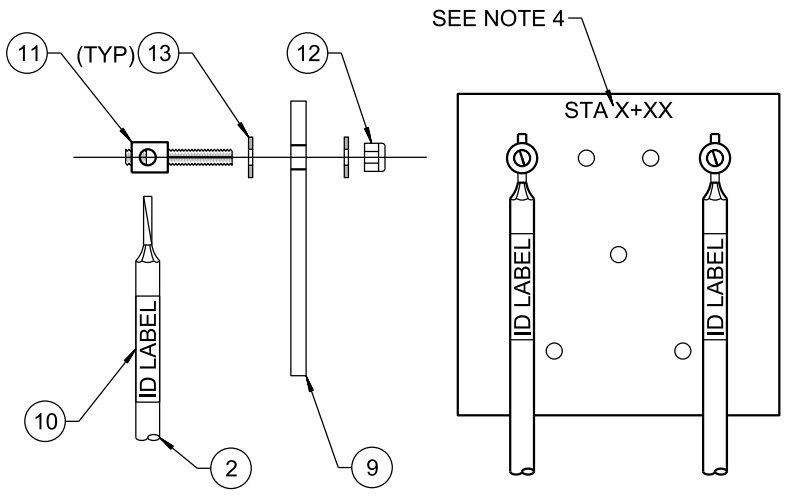

* SEE NOTES ON SHEET 2

SHEET 1 OF 2

REVISION	BY	APPROVED	DATE
ORIGINAL	BM	A. OSKOUJ	12/03
NOTES	BM	A. OSKOUJ	12/06
UPDATED	KA	J. NAGELVOORT	01/12
REDRAFTED	CD	J. NAGELVOORT	09/18
UPDATED	EF	J. NAGELVOORT	10/19

CITY OF SAN DIEGO - STANDARD DRAWING

**AT-GRADE CATHODIC PROTECTION
TEST STATION
INSTALLATION FOR ROADWAYS**

RECOMMENDED BY THE CITY OF SAN DIEGO STANDARDS COMMITTEE

Chungga 10/10/19
COORDINATOR R.C.E. 56523 DATE

DRAWING NUMBER **SDW-121**

NOTES:

1. FOR LOCATION OF TEST STATION, **USE REGIONAL STANDARD DWG WS-03**. EXACT LOCATION SHALL BE APPROVED BY THE CORROSION ENGINEER. IF INSTALLED BEHIND THE SIDEWALK OR IN LANDSCAPED AREA, INSTALL THE TEST BOX LEVEL WITH SIDEWALK OR 1" ABOVE GRADE IN A STEEL REINFORCED CONCRETE COLLAR 24"X24"X 6" OR 24" DIA X 6".
2. FOR UNDEVELOPED AREAS **USE SDW-127**.
3. TO MINIMIZE PIPE COATING DAMAGE AND REPAIR, CONTRACTOR CAN MOVE TEST STATION +/- 25' TO INSTALL TEST STATION WIRES AT NEAREST PIPE JOINT AS SHOWN. EXTERIOR JOINT MORTAR NOT SHOWN FOR CLARITY.
4. REPLACE "STA X+XX" ON TERMINAL BOARD WITH APPROPRIATE PIPELINE STATIONING.

SHEET 2 OF 2

REVISION	BY	APPROVED	DATE	CITY OF SAN DIEGO – STANDARD DRAWING	RECOMMENDED BY THE CITY OF SAN DIEGO STANDARDS COMMITTEE	
ORIGINAL	BM	A. OSKOUJ	12/03		AT-GRADE CATHODIC PROTECTION TEST STATION INSTALLATION FOR ROADWAYS	 10/10/19
NOTES	BM	A. OSKOUJ	12/06	COORDINATOR R.C.E. 56523		DATE
UPDATED	KA	J. NAGELVOORT	01/12	DRAWING		SDW-121
REDRAFTED	CD	J. NAGELVOORT	09/18	NUMBER		
UPDATED	EF	J. NAGELVOORT	10/19			